

**COMPAQ**

[www.compaq.com](http://www.compaq.com)

**COMPAQ**

## Presario

*Mobile Internet PC Safety  
and Comfort Guide*

[www.compaq.com](http://www.compaq.com)



191432-002

© 2001 Compaq Computer Corporation.  
All rights reserved. Printed in the United States,  
Brazil, Canada, Japan, Singapore, Taiwan,  
and the United Kingdom. Compaq is registered  
in the U.S. Patent and Trademark Office.



**Presario Notebook**  
Safety and Comfort Guide

Second Edition (January 2001)  
Part Number 191432-002  
Compaq Computer Corporation

## Notice

© 2001 Compaq Computer Corporation

COMPAQ and the Compaq logo Registered in U.S. Patent and Trademark Office.

All other product names mentioned herein may be trademarks or registered trademarks of their respective companies.

Compaq shall not be liable for technical or editorial errors or omissions contained herein. The information in this document is subject to change without notice.

The information in this publication is subject to change without notice and is provided "AS IS" WITHOUT WARRANTY OF ANY KIND. THE ENTIRE RISK ARISING OUT OF THE USE OF THIS INFORMATION REMAINS WITH RECIPIENT. IN NO EVENT SHALL COMPAQ BE LIABLE FOR ANY DIRECT, CONSEQUENTIAL, INCIDENTAL, SPECIAL, PUNITIVE OR OTHER DAMAGES WHATSOEVER (INCLUDING WITHOUT LIMITATION, DAMAGES FOR LOSS OF BUSINESS PROFITS, BUSINESS INTERRUPTION OR LOSS OF BUSINESS INFORMATION), EVEN IF COMPAQ HAS BEEN ADVISED OF THE POSSIBILITY OF SUCH DAMAGES. THE FOREGOING SHALL APPLY REGARDLESS OF THE NEGLIGENCE OR OTHER FAULT OF EITHER PARTY AND REGARDLESS OF WHETHER SUCH LIABILITY SOUNDS IN CONTRACT, NEGLIGENCE, TORT, OR ANY OTHER THEORY OF LEGAL LIABILITY, AND NOTWITHSTANDING ANY FAILURE OF ESSENTIAL PURPOSE OF ANY LIMITED REMEDY.

The limited warranties for Compaq products are exclusively set forth in the documentation accompanying such products. Nothing herein should be construed as constituting a further or additional warranty.

Compaq Presario Notebook Safety and Comfort Guide  
Second Edition (January 2001)  
Part Number 191432-002

# CONTENTS

<b>Chapter 1 Safety and Comfort</b> .....	<b>1-1</b>
Promoting a Safe and Comfortable Work Environment .....	1-2
Important Choices .....	1-2
Take Action for Safety and Comfort .....	1-2
Key Principles .....	1-3
Finding Your Comfort Zone .....	1-4
A Range of Positions .....	1-4
Different Tasks, Different Postures .....	1-5
Organizing Your Adjustments .....	1-5
Feet, Knees, and Legs .....	1-6
Back .....	1-7
Forearms, Wrists, and Hands .....	1-8
Shoulders and Elbows .....	1-9
Eyes .....	1-9

Arranging Your Work Area . . . . .	1-10
Monitor . . . . .	1-10
Keyboard and Pointing Device . . . . .	1-13
Arm Supports and a Palm Rest . . . . .	1-14
Papers and Books . . . . .	1-15
Phone . . . . .	1-16
Working in Comfort. . . . .	1-17
Using a Notebook Computer . . . . .	1-17
Typing Style . . . . .	1-18
Pointing Style . . . . .	1-19
Using a Keyboard on a Sofa . . . . .	1-20
Taking Breaks and Varying Your Tasks . . . . .	1-21
Monitoring Your Health Habits and Exercise . . . . .	1-22
Organizing Your Adjustments. . . . .	1-23
From the Ground Up . . . . .	1-23
From the Top Down . . . . .	1-23
Self-Check . . . . .	1-24
Seated Position . . . . .	1-24
Shoulders, Arms, Wrists, and Hands . . . . .	1-24
Eyes . . . . .	1-24
Typing Style . . . . .	1-25
Keyboard and Pointing Device . . . . .	1-25
Monitor . . . . .	1-25
Notebook Computing . . . . .	1-26
General Prevention . . . . .	1-26

Electrical and Mechanical Safety Information . . . . .	1-27
Introduction . . . . .	1-27
Product Safety Policy and General Practice . . . . .	1-27
Safety Standards . . . . .	1-27
Installation Requirements . . . . .	1-28
General Precautions for Compaq Products . . . . .	1-28
Precautions for Portable Computer Products . . . . .	1-32
Precautions for Server and Network Products . . . . .	1-32
Precautions for Products with External Television Antenna Connectors . . . . .	1-34
Antenna Grounding . . . . .	1-35
Precautions for Products with Modems, Telecommuni-cations, or Local Area Network Options . . . . .	1-36
Precautions for Products with Laser Devices . . . . .	1-36
For More Information . . . . .	1-38
<b>Chapter 2 Government Approvals . . . . .</b>	<b>2-1</b>
European Union Notice . . . . .	2-1
Federal Communications Commission Notice . . . . .	2-2
Modifications . . . . .	2-2
Cables . . . . .	2-2
Declaration of Conformity for Products Marked with the FCC Logo (United States Only) . . . . .	2-3
Canadian Notice . . . . .	2-3
Avis Canadien . . . . .	2-3
Japanese Notice . . . . .	2-3
Telecommunications Device Approvals . . . . .	2-4

U.S. Modem Regulatory Statements . . . . .	2-4
Applicable certification jack USOC = RJ11C . . . . .	2-4
Canadian Modem Regulatory Statements . . . . .	2-6
U.K. BABT Users Notice. . . . .	2-7
Telephone Network Connection . . . . .	2-7
Auto Dialing with the Modem . . . . .	2-9
Benutzerhinweise für besondere Bestimmungen in Österreich . . . . .	2-9
Hinweis für die Benutzung in osterreich . . . . .	2-9
Wahlsperre . . . . .	2-9
Benutzerhinweise für besondere Bestimmungen in Deutschland . . . . .	2-9
Hinweis für die Benutzung in der Bundesrepublik Deutschland . . . . .	2-9
Brugerinstruktioner i overensstemmelse med danske krav . . . . .	2-10
Opkaldskoder P og T . . . . .	2-10
Speciale gebruiksinstructies voor Nederland . . . . .	2-10
Aansluitfactor . . . . .	2-10
Wachten op kiestoon . . . . .	2-10
Handenvrij bellen . . . . .	2-10
Användarinstruktioner i överensstämmelse med svenska krav. . . . .	2-10
Uppringningskod P och T . . . . .	2-10
New Zealand Modem Regulatory Statements . . . . .	2-11
Voice Support . . . . .	2-12

Safety .....	2-12
Batteries .....	2-12
Power Cords .....	2-12
Laser Assemblies .....	2-13
CDRH Regulations .....	2-13
Using the Computer .....	2-15
German Ergonomics Notice .....	2-15
Mobile Products – German Ergonomics Notice ...	2-15
Locating the Regulatory Compliance	
Markings Labels .....	2-15
Energy Compliance .....	2-18





# Safety and Comfort



**WARNING:** There may be a risk of **serious physical injuries** from working at your computer workstation. Read and follow the recommendations in this section to minimize the risk of injury and to increase your comfort.

Some studies have suggested that long periods of typing, improper workstation setup, incorrect work habits, stressful work conditions and relationships, or problems in your personal health may be linked to injuries. These injuries could include carpal tunnel syndrome, tendinitis, tenosynovitis, and other musculoskeletal disorders.

The warning signs of these disorders can occur in the hands, wrists, arms, shoulders, neck, or back, and can include:

- ◆ Numbness, burning, or tingling
- ◆ Soreness, aching, or tenderness
- ◆ Pain, throbbing, or swelling
- ◆ Tightness or stiffness
- ◆ Weakness or coldness

Symptoms may be felt during typing, while using a mouse, or at other times when no work with the hands is being performed, including during the night when these symptoms might awaken you. If you experience these symptoms, or any other persistent or recurring pain or discomfort that you think may be related to using a computer, you should promptly consult a qualified physician and, if available, your company's health and safety department. The earlier a problem is properly diagnosed and treated, the less chance there is that it will progress to a disabling condition.

The following pages describe proper workstation setup, posture, and health and work habits for computer users. In addition, this Guide contains product safety information applicable to all Compaq products.

---

## Promoting a Safe and Comfortable Work Environment

Posture, lighting, furniture, work organization, and other work conditions and habits may affect the way you feel and how well you work. By adjusting your work environment and personal practices, you may be able to minimize fatigue and discomfort, and reduce the risk of resulting strains that some scientists believe can lead to injury.

### Important Choices

If you share a computer with others, readjust the work environment to your needs. Each time you sit down to work, adjust into your comfort zone.

Whenever you use a computer, you make choices that can affect your comfort and potentially your safety. This is true whether you use a full-size keyboard and monitor on a desk, a notebook computer, or a wireless keyboard on your lap. In every case, you choose your working posture and your body's position relative to your keyboard, pointing device, monitor, remote control, phone, and any reference books and papers. You may also have some control over lighting and other factors.

### Take Action for Safety and Comfort

Many factors in our work environment determine whether we work efficiently and in a manner that promotes good health and safety.

By considering, acting on, and periodically reevaluating the recommendations in this Section, it is possible to create a safer, more comfortable, healthful, and efficient work environment.



**NOTE:** Some scientists believe that working intensely, or for a long time in uncomfortable or unnatural positions, may pose risks, such as those mentioned in the warning. The information included in this Section is designed to help you work more safely by recommending ways to work more comfortably and effectively.



**HINT: SELF-CHECK:** After reviewing the information in this chapter, double-check your postures and habits using the section *Self-Check* on page 24.

---

## Key Principles

To promote safety and comfort, follow these principles whenever you use your computer.



### Adjust

Adjust your body position and your work equipment. There is no one “right” position. Find your comfort zone, as described in this Section, and when working at your computer, frequently adjust within this zone.

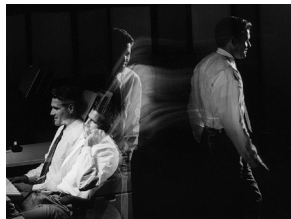

### Move

Vary your tasks so that you can move around; avoid sitting in one posture all day. Perform tasks that require walking.



### Relax

Build positive relationships at work and home. Relax and strive to reduce sources of stress. Stay aware of physical tension such as clenching your muscles and shrugging your shoulders. Continually release tension. Take frequent short breaks.



### Listen

Listen to your body. Pay attention to any tension, discomfort, or pain you may feel, and take immediate action to relieve it.



### Remember

Remember to exercise regularly and maintain general fitness. Doing this will help your body withstand the rigors of sedentary work. Respect any medical conditions you may have or other health factors you may know of. Adjust your work habits accordingly.

## Finding Your Comfort Zone

### A Range of Positions

Rather than working in a single posture, find your **comfort zone**. Your comfort zone is a *range* of positions that is generally appropriate and comfortable for your given work situation.



### Vary Your Posture

Depending on your tasks, you may find a range of seated and standing postures that are comfortable. Within your comfort zone, change postures often throughout the day.

### Move

Sitting still for long periods can cause discomfort and muscle fatigue. Changing postures is good for many parts of your body, including your spine, joints, muscles, and circulatory system.

Within your comfort zone, change postures often throughout the day. Take frequent short breaks: stand up, carefully stretch, or walk around. Frequently switch to brief tasks that require getting up, such as retrieving output from a printer, filing paperwork, or consulting a colleague down the hall.

If your furniture offers a wide range of adjustments, you might find it comfortable to switch back and forth between sitting and standing positions.



### **Different Tasks, Different Postures**

Your choice of posture within your comfort zone may vary with your task. For example, you may find a reclined posture most comfortable for computer tasks, and a more upright posture more comfortable for tasks requiring frequent reference to papers or books.

### **Organizing Your Adjustments**

The order in which you make various adjustments to your body position and work area may vary depending on the adjustability of your furniture. For tips on how to order your adjustments see the section *Arranging Your Work Area* on page 10.



**HINT: THAT AFTERNOON SLUMP:** Pay particular attention to adjusting your posture in the afternoon when you may tend to get fatigued.

**HINT: EVERYTHING IS CONNECTED:** When you reposition any one part of your body, you may need to adjust other parts as well.

#### **AVOID!**

- ◆ Don't sit in one fixed posture all day.
- ◆ Avoid slouching forward.
- ◆ Be sure not to lean back too far.

---

## Feet, Knees, and Legs

Make sure your feet can rest solidly and comfortably on the floor while sitting. Use an adjustable work surface and chair that allow your feet to rest firmly on the floor, or use a footrest. If you use a footrest, be sure it is wide enough to accommodate different leg positions within your comfort zone.

### Providing enough leg room

Be sure you have sufficient space under your work surface for your knees and legs. Avoid concentrated pressure points along the underside of your thigh near the knee and the back side of your lower leg. Stretch your legs and vary your leg posture throughout the day.



#### RIGHT!

Rest your feet firmly on the floor or a footrest.



#### WRONG!

Don't dangle your feet and compress your thighs.



**HINT: WALK:** Get up from your desk frequently and take brief walks.

**HINT: LEG COMFORT:** Vary your leg positions throughout the day.

#### AVOID!

Avoid placing boxes or other items under your desk that limit your leg room. You should be able to pull yourself all the way up to your desk without interference.

---

## Back

Use your chair to fully support your body. Distribute your weight evenly and use the entire seat and backrest to support your body. If your chair has adjustable low back support, match the contours of the chair's backrest to the natural curve of your lower spine.

### Getting comfortable

Always make sure your lower back is well-supported. Make sure it feels comfortable in the position in which you are working.



#### RIGHT!

Distribute your weight evenly and use the entire seat and backrest to support your body.



#### WRONG!

Don't slouch forward.



**HINT: ADJUST OFTEN:** If your chair is adjustable, experiment with the adjustments to find numerous comfortable positions, then adjust the chair frequently.

#### AVOID!

If you get a new adjustable chair, or if you share a chair with someone else, don't assume the settings are properly set for you.



---

## **Forearms, Wrists, and Hands**

Keep your forearms, wrists, and hands aligned in a straight, neutral position, whether you are working at a desk or table, or sitting on a couch or bed. Avoid bending or angling your wrists while typing or using a pointing device.

### **Don't anchor your wrists**

When typing, do not anchor or rest your wrists on your work surface, your thighs, or a palm rest (sometimes called a wrist rest). Resting your palms while typing may be harmful because it can cause you to bend your wrists back and can apply pressure to the undersides of your wrists. A palm rest is designed to provide support during pauses, when you are not typing.



**RIGHT!**

Hold a straight, neutral wrist position while typing.



**WRONG!**

Don't rest your palms on a work surface while typing.



**RIGHT!**

Hold a straight, neutral wrist position while typing.



**WRONG!**

Don't angle your wrists; this may cause unnecessary strain.



#### **HINT: Split Keyboards**

If you find it difficult to type with a straight, neutral wrist position, you may want to try a split keyboard. Be aware, however, that improper setup or posture while using a split keyboard can increase bending in your wrists. So if you try one, set it up properly to align your forearms, wrists, and hands.

**AVOID!** Be sure not to rest your wrists on sharp edges.

### **Shoulders and Elbows**

Adjust your chair height or keyboard height so that your shoulders are relaxed and your elbows hang comfortably at your sides. Adjust your keyboard slope so that your wrists are straight.

#### **Checking elbow height**

Position your elbows in a zone that is near the height of your keyboard's home row (the row that includes the letters G and H). This position allows you to relax your shoulders. If you have long upper arms, you may find you need to position your elbows a bit below the height of home row in order to provide enough space under the work surface for your knees and legs.



#### **RIGHT!**

Turn your chair to the side to help determine if your elbow height is near the height of your keyboard's home row.



**HINT: RELAX:** Remember to relax, particularly in areas where muscle tension often builds, such as your shoulders.

### **Eyes**

Working at your computer for long periods can be a visually demanding task and may cause your eyes to become irritated and fatigued. Therefore, you should give special attention to vision care, including the following recommendations:

#### **Resting your eyes**

Give your eyes frequent breaks. Periodically look away from the monitor and focus at a distant point. This may also be a good time to stretch, breathe deeply, and relax.

---

### **Cleaning your monitor and eyeglasses**

Keep your display screen and your eyeglasses or contact lenses clean. If you use a glare-reduction filter, clean it according to the manufacturer's directions.

### **Having your eyes examined**

To be sure that your vision is adequately corrected, have your eyes examined regularly by a vision care specialist. Consider having glasses made that are specifically suited for working with a computer monitor. If you wear bifocals or trifocals, you may find these special monofocal glasses more comfortable for computer use. For more information, see *Adjusting monitor height for bifocal and trifocal users* on page 12.



#### **HINT: Eye Comfort**

While looking at your monitor and also while resting your eyes, remember to blink. This helps keep your eyes naturally protected and lubricated and helps prevent dryness, a common source of discomfort.

#### **HINT: Eye Break**

Give your eyes frequent rests by focusing them on a distant point.

## **Arranging Your Work Area**

You may find a range of monitor heights that allows your head to be balanced comfortably over your shoulders.

### **Monitor**

You will reduce eye strain and muscle fatigue in your neck, shoulders, and upper back by properly positioning your monitor and adjusting its angle.

---

### Positioning the monitor

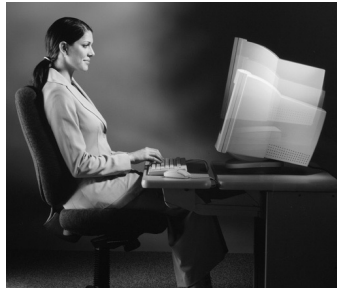

Place the monitor directly in front of you. To determine a comfortable viewing distance, stretch your arm toward the monitor and notice the location of your knuckles. Place your monitor near that location. You should be able to clearly see the text on your monitor.

### Adjusting the monitor height

Your monitor position should allow your head to be balanced comfortably over your shoulders. It should not cause your neck to bend forward uncomfortably or backward to any degree. You may find it more comfortable to position the monitor so that the top line of text is just below your eye height. Your eyes should look slightly downward when viewing the middle of the screen.

Many computer designs allow you to place the monitor on top of the system unit. If this places the monitor too high, you may want to move the monitor to the desktop. On the other hand, if the monitor sits on your work surface and you feel any discomfort in your neck or upper back, the monitor may be too low. In that case, try using a thick book or a monitor stand to raise the monitor.

### Tilting the monitor

Tilt the monitor so that it faces your eyes. In general, the monitor screen and your face should be parallel to each other. To check for correct monitor tilt, have someone hold a small mirror in the center of the viewing area. When sitting in your normal work posture, you should be able to see your eyes in the mirror.



#### **HINT: Eye Height**

Your eye height will change considerably whether you use a reclining or upright posture, or some posture in between. Remember to adjust your monitor's height and tilt each time your eye height changes as you move through your comfort zone.

#### **AVOID!**

If you look at the monitor more than you look at paper documents, avoid placing your monitor to the side.

---

### **Adjusting monitor height for bifocal and trifocal users**

If you wear bifocals or trifocals, it's especially important to properly adjust your monitor height. Avoid tilting your head back to view the screen through the lower portion of your glasses; this could lead to muscle fatigue in your neck and back. Instead, try lowering your monitor. You may want to consider using monofocal glasses that are specially made for computer use.



#### **WRONG!**

If you wear bifocals or trifocals, don't position your monitor so high that you have to tilt your head back to view the screen.



#### **HINT: Notebook Viewing**

Whenever using a notebook computer for long periods, you may find it more comfortable to connect a full-size monitor. A separate monitor gives you a wider range of viewing distance and height options.



#### **HINT: Adjusting Brightness and Contrast**

Reduce the potential for eye discomfort by using brightness and contrast controls on your monitor to improve the quality of text and graphics.

### **Eliminating glare and reflections on your monitor**

Take the time to eliminate glare and reflections. To control daylight, use blinds, shades, or drapes, or try other glare-reducing measures. Use indirect or reduced lighting to avoid bright spots on your display screen.

If glare is a problem, consider these actions:

- ◆ Move your monitor to a place where glare and bright reflections are eliminated.
- ◆ Turn off or reduce ceiling lights and use task lighting (one or more adjustable lamps) to illuminate your work.
- ◆ If you cannot control the ceiling lights, try positioning your monitor between rows of lights instead of directly beneath a row of lights.
- ◆ Attach a glare-reduction filter to your monitor.

- 
- ◆ Place a visor on your monitor. This device may be as simple as a piece of cardboard extending out over the monitor's top front edge.
  - ◆ Avoid tilting or swiveling your display in a way that leads to an uncomfortable head or upper back posture.



**HINT: Eliminating Glare**

Try positioning your monitor so that its side faces the windows.

**AVOID!**

- ◆ Avoid compromising your posture to compensate for glare or reflections.
- ◆ Try to avoid bright light sources in your field of vision. For example, don't face an uncovered window during daylight hours.

**Keyboard and Pointing Device**

Place your keyboard, mouse, and other input devices, so that you can use them with your body in a relaxed, comfortable position. In this way, you don't have to reach or shrug your shoulders while working.

**Positioning the keyboard**

Position the keyboard directly in front of you to avoid twisting your neck and torso. This makes it possible to type with your shoulders relaxed and your upper arms hanging freely at your sides.

**Adjusting the keyboard height and slope**

Your elbow height should be near the height of your keyboard's home row (see illustration under *Shoulders and Elbows* on page 9). Adjust your keyboard slope so that your wrists are straight.

**Aligning the mouse and keyboard**

When using a mouse or detached trackball, position the device immediately to the right or left of your keyboard.

**Using a keyboard tray comfortably**

If you use a keyboard tray, make sure it is wide enough to accommodate your pointing device, such as a mouse or trackball. Otherwise, you will probably place the mouse on your desktop, higher and farther away than the keyboard. This will lead you to stretch forward repeatedly, and uncomfortably, to reach the mouse.



**RIGHT!**

Position your pointing device immediately to the right or left of your keyboard.



**WRONG!**

Don't position your keyboard and pointing device at different levels and distances.

## **Arm Supports and a Palm Rest**

You may find that supports for your forearms or hands allow you to be more relaxed and comfortable.

### **Using arm supports**

Some chairs and desks provide padded areas for resting your arms. You may find it comfortable to rest the middle of your forearms on these supports while typing, pointing, or pausing. Arm supports are properly adjusted when your shoulders are in a comfortable position and your wrists are straight.

### **Using a palm rest**

A palm rest is designed to provide support during pauses, not during typing or pointing. While typing or using a pointing device, keep wrists free to move, not anchored or resting on a palm rest, the desk, or your thighs.

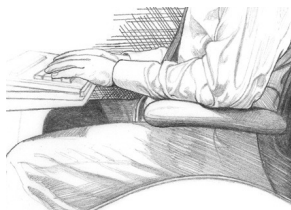

**RIGHT!**

You may find that arm supports help you relax your shoulders and keep your wrists free to move while typing.



**HINT: For Pauses Only**

Palm rests should only be used during pauses, when you are not typing or using your pointing device.

**AVOID!**

Armrests should not cause you to:

- ◆ Shrug or drop your shoulders.
- ◆ Put excessive pressure on your elbows.
- ◆ “Wing” your arms (extend elbows out to the sides).

**Papers and Books**

Select a work surface or surfaces that are large enough to hold the computer equipment and any additional items required for your work. To help minimize eye fatigue, position any materials to which you frequently refer at about the same viewing distance.

**Minimizing your reach**

Arrange your frequently used papers, books, or other items to minimize the distance you reach for them. If you frequently refer to books, papers, and writing materials, and if you use a keyboard tray, make sure the tray, when extended, doesn't cause you to lean forward or reach excessively. This can stress your shoulders and back. If you find that such stress occurs, you may want to consider a different type of work setup.

**Using a document holder**

If you use a document holder, position it near the monitor at the same distance, height, and angle as the monitor. Positioning the holder in this way can increase your neck comfort as you refer back and forth between your papers and the display screen, by helping you keep your head balanced over your shoulders.

If your primary task is typing from paper documents, you may find it more comfortable to place your document holder directly in front of you and your monitor slightly to one side, or on a slant board between your monitor and keyboard. Consider this option only if you spend more time looking at the paper than at your monitor.



**WRONG!**

Don't arrange your work area in a way that causes you to repeatedly strain forward to see and reach frequently used items such as books, papers, or a phone.



---

**Phone**

Cradling your phone between your ear and shoulder may lead to neck, shoulder, and back discomfort. If you use your phone a lot, try using a headset or positioning your phone so you pick it up with your non-dominant hand. This frees your dominant hand for note-taking. When not in use, place the phone within easy reach.

**RIGHT!**

Use a headset to free your hands and help you avoid uncomfortable positions.

**WRONG!**

Don't cradle your phone between your ear and shoulder.

---

## Working in Comfort

### Using a Notebook Computer

Maintaining a high level of comfort when using a notebook computer may be more challenging than when using a desktop computer. Therefore, you should be especially alert to your body's signals, such as any feeling of discomfort. Also, be sure to adhere to the key principles presented earlier in this section.

The following strategies are intended to help you maintain comfort when using a notebook computer:



#### On the road

In a hotel, use a blanket for padding your chair and a rolled towel as an inventive way to support your lower back area.

#### Seeking comfort

When working with a notebook computer, keep your shoulders and neck relaxed and your head balanced over your shoulders. You may find it comfortable to periodically use a support surface (your briefcase, a bed table, firm blanket, pillow, or large book) between your lap and your notebook computer.

#### Being inventive

Use pillows, blankets, towels, and books to:

- ◆ Raise the height of your seat.
- ◆ Create a footrest, if needed.
- ◆ Support your back.
- ◆ Raise your computer to elevate the keyboard and display.
- ◆ Provide arm supports, if you are working on a couch or bed.
- ◆ Provide padding wherever needed.

#### Transporting the computer

If you load up your carrying case with accessories and papers, avoid shoulder strain by using a cart or a carrying case with built-in wheels.



#### HINT: Notebook Comfort

When you must work where proper seating or support may not be available, such as on airplanes or in wilderness areas, change your position often while working and take brief breaks more frequently.



#### **HINT: Long Hours of Use**

You may find it more comfortable to use a full-size keyboard, monitor, and detached mouse or trackball with your notebook computer. This is especially important when working on your notebook computer for long hours.

### **Typing Style**

Observe your typing style and notice how you use your fingers and hands. Avoid keeping any unnecessary tension in your thumbs and fingers. Observe whether you have a heavy touch or a light touch while typing. Use the minimum amount of force needed to depress the keys.

#### **Reaching for keys and key combinations**

To reach keys that are not near your keyboard's home row, move your whole arm; avoid stretching your fingers and angling your wrists. When pressing two keys simultaneously, such as **Ctrl+C** or **Alt+F**, use two hands instead of contorting one hand to reach both keys



#### **RIGHT!**

Relax your thumbs and fingers while typing and pointing; notice and release excess tension.



#### **WRONG!**

Don't type or point with unnecessary tension in your thumbs and fingers.



#### **HINT: Keep it Light**

If your typing is on the heavy side, teach yourself to lighten up. Press the keys more gently.



#### **HINT: “Hunt-and-Peck” Typing**

Non-touch-typing causes the neck to bend forward repeatedly. To minimize this repetitive movement, learn how to touch-type so you don't need to look down at the keyboard as often.

#### **AVOID!**

Avoid banging on the keys. Don't use more force than needed to press the keys.

### **Pointing Style**

Use your whole arm and shoulder to move the mouse, not just your wrist. Don't rest or anchor your wrist while using your pointing device; keep your wrist, arm, and shoulder free to move.

#### **Adjusting software controls**

You can use the software control panel to adjust the properties of your pointing device. For example, to reduce or eliminate mouse-lifting, try increasing the acceleration setting. If you use a pointing device with your left hand, the software control panel will allow you to switch the button assignments for maximum comfort.

#### **Clean frequently**

Dirt can make pointing more difficult. Remember to clean your mouse or trackball frequently.



#### **RIGHT!**

Keep your wrist in a straight, neutral position when using your pointing device.



#### **WRONG!**

Don't angle your wrist when using your pointing device.



#### **HINT: Pointing Comfort**

When using a mouse or trackball, hold it loosely. Keep your hand relaxed, and click the buttons using a light touch. When you are not using your pointing device, don't hold onto it; let it go.

#### **Switch Hands**

To give your hand a break, you may choose to control your mouse or trackball with the opposite hand for a while.

**AVOID!** Avoid gripping or pinching your mouse tightly.

### **Using a Keyboard on a Sofa**

Even if you use your keyboard in a seemingly comfortable place such as a sofa, bed, or your favorite lounge chair, you can still cause discomfort by sitting in an awkward position or in one position for long periods. Remember to frequently make changes to your position, within your comfort zone, and to take short breaks.

#### **Aligning forearms, wrists, and hands**

When working on a keyboard on your lap, keep your forearms, wrists, and hands comfortably aligned with each other in a straight, neutral line. Avoid bending or angling your wrists. If your keyboard has palm rests, use them during pauses, not while typing or using a pointing device.

#### **RIGHT!**



Experiment with positioning pillows under your forearms; they may help keep your shoulders relaxed and your wrists straight.



#### **HINT: Even on a sofa**

Remember to properly support your lower back.

- AVOID!**
- ◆ Avoid slouching.
  - ◆ Be sure not to recline too much; this may fatigue your neck and upper back.
  - ◆ Don't bend or angle your wrists.
  - ◆ Avoid sitting completely still and working without breaks for long periods.

---

## **Taking Breaks and Varying Your Tasks**

As noted earlier in this section, your furniture placement, office equipment, and lighting are only a few of the factors that determine comfort. Your work habits are also very important. Remember the following:

### **Take breaks**

When you work at your computer for long periods, take short breaks at least once per hour and preferably more often. You may find that frequent, short breaks will benefit you more than fewer, longer breaks.

If you find that you forget to take breaks, use a timer or specialized software. Several software tools are available that remind you to take breaks at intervals you specify.

During your breaks, stand up and stretch, especially any muscles and joints you may have held in an extended static posture while using the computer.

### **Vary your tasks**

Examine your work habits and the types of tasks you perform. Break up the routine and try to vary your tasks during the day. By doing so, you may avoid sitting in one position or performing the same activities continuously for several hours using your hands, arms, shoulders, neck, or back. For example, you could print out your work to proofread rather than proofing from your monitor.

### **Reduce sources of stress**

Take an inventory of things at work that are stressful to you. If you perceive that your physical or psychological health is being affected, take time to evaluate what changes you can make to reduce or eliminate the sources of stress.



#### **HINT: Try it and see**

Contrary to what some may believe, several studies have found that productivity does NOT decline when frequent short breaks are added to the day.

#### **Breathe deeply**

Breathe fresh air deeply and regularly. The intense mental concentration that may accompany computer use may tend to cause breath-holding or shallow breathing.

---

**Monitoring Your Health Habits and Exercise**

The comfort and safety of working at your computer can be affected by your general state of health. Studies have shown that a variety of health conditions may increase the risk of discomfort, muscle and joint disorders, or injuries.

These preexisting conditions include:

- ◆ Hereditary factors
- ◆ Arthritis and other connective tissue disorders
- ◆ Diabetes and other endocrine disorders
- ◆ Thyroid conditions
- ◆ Vascular disorders
- ◆ Generally poor physical condition and dietary habits
- ◆ Prior injuries, traumas, and musculoskeletal disorders
- ◆ Excessive weight
- ◆ Stress
- ◆ Smoking
- ◆ Advancing age
- ◆ Pregnancy, menopause, and other conditions affecting hormone levels and water retention

**Monitoring personal tolerance levels and limits**

Different users of computers have different levels of tolerance for intensive work over a long period. Monitor your personal tolerance levels and avoid regularly exceeding them.

If any of the listed health conditions apply to you, it is particularly important to know and monitor your personal limits.

**Cultivating health and fitness**

Additionally, your overall health and tolerance for the rigors of work typically can be improved by avoiding adverse health conditions and by exercising regularly to improve and maintain your physical fitness.

---

## Organizing Your Adjustments

The order in which you follow the advice in this chapters depends on the adjustability of your work surface.

If your work surface height adjusts, then systematically adjust yourself and your computer “from the ground up.”

If you have a fixed desk or table, systematically adjust yourself and your computer “from the top down.”

### From the Ground Up

1. Seat height: you should be able to plant your feet firmly on the floor.
2. Chair back angles and lower back support: your back should be well supported.
3. Keyboard height: home row should be near your elbow height.
4. Keyboard slope: wrists should be straight.
5. Pointing device: should be placed to the immediate left or right of your keyboard.
6. Optional forearm supports: shoulder should not be elevated or dropped.
7. Monitor distance, height, and angle: should allow your head to be balanced comfortably over your shoulders.
8. Document holder, phone, and reference materials: frequently used items should be within easy reach.

### From the Top Down

1. Seat height: elbow height should be near your keyboard’s home row.
2. Footrest, if you need one.
3. Follow steps 2 through 8 above.



#### **HINT: Be Inventive**

Adjustable furniture designed for computer use may not always be available. However, you can use towels, pillows, blankets, and books in many ways, such as to:

- ◆ Raise the height of your chair.
- ◆ Create a footrest.
- ◆ Support your back.
- ◆ Elevate the keyboard or display.
- ◆ Provide arm supports if you are working on a sofa or bed.
- ◆ Provide padding wherever needed.



---

## Self-Check

To increase your comfort and reduce potential safety risks, use this checklist to help you evaluate your work posture and habits.

### Seated Position

- ◆ Have you found a range of seated postures that are most comfortable for you?
- ◆ Are you changing postures within your “comfort zone” throughout the day, especially in the afternoon?
- ◆ Are your feet firmly planted?
- ◆ Are the undersides of your thighs near your knees free of pressure?
- ◆ Are the backs of your lower legs free of pressure?
- ◆ Is there sufficient space under your work surface for your knees and legs?
- ◆ Is your lower back supported?

### Shoulders, Arms, Wrists, and Hands

- ◆ Are your shoulders relaxed?
- ◆ Are your hands, wrists, and forearms aligned in a straight, neutral position?
- ◆ If you use arm supports, are they adjusted so that your shoulders are relaxed and your wrists are straight?
- ◆ Are your elbows in a relaxed position near your body?
- ◆ Do you avoid resting your hands and wrists while typing or pointing?
- ◆ Do you avoid resting your hands and wrists on sharp edges?
- ◆ Do you avoid cradling the phone between your ear and shoulder?
- ◆ Are items you use frequently, such as your phone and reference materials, easy to reach?

### Eyes

- ◆ Do you rest your eyes frequently by focusing on a distant point?
- ◆ Do you get your eyes examined regularly by a vision care specialist?
- ◆ Do you blink enough?
- ◆ If you wear bifocals or trifocals, do you avoid tilting your head back to see the monitor?

---

**Typing Style**

- ◆ Are you training yourself to lighten up when you find you are pounding on the keys?
- ◆ If you are not a touch typist, have you been taking typing lessons?
- ◆ Are you training your fingers to relax when they become tense?
- ◆ Do you use your whole arm to reach for keys not located near the home row?

**Keyboard and Pointing Device**

- ◆ Is your keyboard positioned directly in front of you?
- ◆ Are your keyboard height and slope adjusted so that your wrists are straight and your shoulders relaxed?
- ◆ If you are typing with the keyboard on your lap, are your shoulders relaxed and your wrists straight?
- ◆ If you are using a mouse or detached trackball, is it placed to the immediate right or left of your keyboard?
- ◆ If you are using a mouse or trackball, are you holding it loosely, with a relaxed hand?
- ◆ Do you let go of your pointing device when you are not using it?
- ◆ Are you using a light touch when you click the buttons on your pointing device (mouse, trackball, touchpad, or pointing stick)?
- ◆ Are you cleaning your mouse or trackball frequently?

**Monitor**

- ◆ Is your monitor positioned in front of you and at a comfortable viewing distance, about arm's length? Or if you look at a paper document more than your monitor, is your document holder in front of you with your monitor to one side?
- ◆ Are the text and images on your monitor easily visible in a comfortably seated position?
- ◆ Have you eliminated glare and bright reflections on your monitor, without compromising your posture?
- ◆ Is your monitor's entire viewing area located just below your eye height?
- ◆ Is your monitor tilted so your face and the monitor are parallel?
- ◆ Have you adjusted the brightness and contrast controls to improve the quality of text and graphics?
- ◆ Is your document holder positioned near the monitor, at the same distance, height, and angle as the monitor?

---

**Notebook Computing**

- ◆ Do you change postures frequently?
- ◆ Do you avoid resting your wrists on your thighs while typing?
- ◆ To avoid neck fatigue when using the computer on a sofa or bed, do you avoid reclining too far?
- ◆ Where possible, have you tried using a full-size keyboard and detached pointing device, such as a mouse or trackball, with your notebook computer?
- ◆ Similarly, have you tried using a full-size monitor?

**General Prevention**

- ◆ Do you take breaks and walk around briefly, at least once per hour?
- ◆ Do you exercise regularly?
- ◆ Periodically, do you take inventory of the stress in your life and change what is within your control to change?
- ◆ If you experience any symptoms that you think may relate to your using a computer, whether you experience them during work or at other times, have you consulted a doctor and, if available, your company's health and safety department?

**HINT: DOUBLE-CHECK**

- ◆ Review your postures and habits using this checklist.
- ◆ Periodically reread this section.
- ◆ Listen to your body.

Anytime you make changes to your tasks, work area, or posture, “listen” to your body. Its signals of comfort or discomfort will help you know whether your adjustments are right.

---

## Electrical and Mechanical Safety Information

### Introduction

Compaq products are designed to operate safely when installed and used according to general safety practices. The guidelines included in this section explain the potential risks associated with computer operation and provide important safety practices designed to minimize these risks. By carefully following the information contained in this section, you can protect yourself from hazards and create a safer computer work environment.

This section provides information on the following topics:

- ◆ Product safety policy
- ◆ Product installation requirements
- ◆ General safety precautions for all Compaq products

If you have a serious concern regarding the safe use of the equipment that your Compaq authorized service provider cannot address, call Compaq Customer Support for your area.

### Product Safety Policy and General Practice

Compaq products are designed and tested to meet IEC 950, the Standard for the Safety of Information Technology Equipment. This is the International Electrotechnical Commission's safety standard covering the type of equipment that Compaq manufactures. Testing may include evaluation according to other criteria such as many of the international, national, and regional standards based on deviations to IEC 950.

### Safety Standards

The IEC 950 standards provide general safety design requirements that reduce the risk of personal injury to both the computer user and the service provider. These standards protect against the following hazards:

- ◆ **Electric shock** Hazardous voltage levels contained in parts of the product
- ◆ **Fire** Overloads, temperature, material flammability
- ◆ **Mechanical** Sharp edges, moving parts, instability
- ◆ **Energy** Circuits with high energy levels (240 volt amperes) or potential as burn hazards
- ◆ **Heat** Accessible parts of the product at high temperatures
- ◆ **Chemical** Chemical fumes and vapors
- ◆ **Radiation** Noise, ionizing, laser, ultrasonic wave

---

## Installation Requirements

Compaq products operate safely when used according to their marked electrical ratings and product usage instructions. Use facilities that comply with the following electrical codes to ensure the safe operation of Compaq products:

- ◆ In the United States, operate the product in commercial or residential structures that have electrical installation in compliance with American National Standards Institute/National Fire Protection Association (ANSI/NFPA) 70, United States National Electric Code, or ANSI/NFPA 75, Protection of Electronic Computer/Data Processing Equipment, with branch circuit current protection of up to 20 amperes.
- ◆ In Canada, operate the product in commercial or residential structures that have electrical installation in compliance with the Canadian Standards Association (CAN/CSA) C22.1, Canadian Electrical Code.
- ◆ In all other countries, operate the product in commercial or residential structures that have electrical installation in compliance with local and regional office and residential electrical wiring codes such as International Electrotechnical Commission (IEC) 364 parts 1 through 7.



**NOTE:** Do not use Compaq products in areas classified as hazardous locations. Such areas include patient care areas of medical and dental facilities, oxygen-laden environments, or industrial facilities. Contact your local electrical authority governing building construction, maintenance, or safety for more information regarding the installation of any product.

For more information, please consult the information, manuals, and literature provided with your product or contact your local sales representative.

## General Precautions for Compaq Products

Retain the product's safety and operating instructions for future reference. Follow all operating and usage instructions. Observe all warnings on the product and in the operating instructions.

To reduce the risk of fire, bodily injury, and damage to the equipment, observe the following precautions.

### Damage requiring service

Unplug the product from the electrical outlet and take the product to a Compaq authorized service provider under the following conditions:

- ◆ The power cord, extension cord, or plug is damaged.
- ◆ Liquid has been spilled or an object has fallen into the product.
- ◆ The product has been exposed to water.
- ◆ The product has been dropped or damaged in any way.

- 
- ◆ There are noticeable signs of overheating.
  - ◆ The product does not operate normally when you follow the operating instructions.

### **Servicing**

Except as explained elsewhere in the Compaq documentation, do not service any Compaq product yourself. Opening or removing covers that are marked may expose you to electric shock. Service needed on components inside these compartments should be done by a Compaq authorized service provider.

### **Mounting accessories**

Do not use the product on an unstable table, cart, stand, tripod, or bracket. The product may fall, causing serious bodily injury and serious damage to the product. Use only with a table, cart, stand, tripod, or bracket recommended by the manufacturer, or sold with the product. Any mounting of the product should follow the manufacturer's instructions, and should use a mounting accessory recommended by the manufacturer.

### **Ventilation**

Slots and openings in the product are provided for ventilation and should never be blocked or covered, since these ensure reliable operation of the product and protect it from overheating. The openings should never be blocked by placing the product on a bed, sofa, carpet, or other similar, flexible surface. The product should not be placed in a built-in apparatus such as a bookcase or rack unless the apparatus has been specifically designed to accommodate the product, proper ventilation is provided for the product, and the manufacturer's instructions have been followed.

### **Water and moisture**

Do not use the product in a wet location.

### **Grounded (earthed) products**

Some products are equipped with a three-wire electrical grounding-type plug that has a third pin for grounding. This plug only fits into a grounded electrical outlet. This is a safety feature. Do not defeat the safety purpose of the grounding-type plug by trying to insert it into a non-grounded outlet. If you cannot insert the plug into the outlet, contact your electrician to replace the obsolete outlet.

---

### **Power sources**

The product should be operated only from the type of power source indicated on the product's electrical ratings label. If you have questions about the type of power source to use, contact your Compaq authorized service provider or local power company. For a product that operates from battery power or other power sources, refer to the operating instructions included with the product.

### **Accessibility**

Be sure that the power outlet you plug the power cord into is easily accessible and located as close to the equipment operator as possible. When you need to disconnect power to the equipment, be sure to unplug the power cord from the electrical outlet.

### **Voltage select switch**

Ensure that the voltage select switch is in the correct position for the type of voltage you use (115 VAC or 230 VAC).

### **Internal battery**

Your computer may contain an internal battery-powered real-time clock circuit. Do not attempt to recharge the battery, disassemble it, immerse it in water, or dispose of it in fire. Replacement should be done by a Compaq authorized service provider using the Compaq spare part for the computer.

### **Power cords**

If you have not been provided with a power cord for your computer or for any AC-powered option intended for use with your computer, you should purchase a power cord that is approved for use in your country.

The power cord must be rated for the product and for the voltage and current marked on the product's electrical ratings label. The voltage and current rating of the cord should be greater than the voltage and current rating marked on the product. In addition, the diameter of the wire must be a minimum of 0.75 mm<sup>2</sup>/18AWG and the cord should be between 5 and 6.5 feet (1.5 and 2 meters) long. If you have questions about the type of power cord to use, contact your Compaq authorized service provider.

Route the power cord so that it will not be walked on, tripped over, or pinched by items placed upon or against it. Pay particular attention to the plug, electrical outlet, and the point where the cord exits the product.

---

### **Protective attachment plug**

In some countries, the product cord set may be equipped with a wall plug having overload protection. This is a safety feature. If the plug needs to be replaced, be sure the Compaq authorized service provider uses a replacement plug specified by the manufacturer as having the same overload protection as the original plug.

### **Extension cord**

If an extension cord or power strip is used, make sure that the cord or strip is rated for the product and that the total ampere ratings of all products plugged into the extension cord or power strip do not exceed 80% of the extension cord or strip ampere ratings limit.

### **Overloading**

Do not overload an electrical outlet, power strip, or convenience receptacle. The overall system load must not exceed 80% of the branch circuit rating. If power strips are used, the load should not exceed 80% of the power strip input rating.

### **Cleaning**

Unplug the product from the wall outlet before cleaning. Do not use liquid cleaners or aerosol cleaners. Use a damp cloth for cleaning.

### **Heat**

The product should be placed away from radiators, heat registers, stoves, or other pieces of equipment (including amplifiers) that produce heat.

### **Replacement parts**

When replacement parts are required, be sure the service provider uses replacement parts specified by Compaq.

### **Safety check**

Upon completion of any service or repairs to the product, have your Compaq authorized service provider perform safety checks to determine that the product is in proper operating condition.

### **Options and upgrades**

Use only the options and upgrades recommended by Compaq.



---

### Hot surfaces

Allow the equipment's internal components and hot-pluggable drives to cool before touching them.

### Object entry

Never push a foreign object through an opening in the product.

## Precautions for Portable Computer Products

In addition to the general precautions described earlier in this section, be sure to observe the following precautions when operating a portable computer product. Failure to observe these precautions could result in fire, bodily injury, and damage to the equipment.

- ◆ **Monitor Support Cover** Do not place a monitor with an unstable base or a monitor heavier than 55 pounds (25 kilograms) on top of a monitor support cover. Instead, place the monitor on a work surface next to the docking base.
- ◆ **Rechargeable Battery Pack** Do not crush, puncture, or incinerate the battery pack or short the metal contacts. In addition, do not attempt to open or service the battery pack.
- ◆ **Docking Base** To avoid pinching your fingers, do not touch the rear of the computer when docking it into a base.

## Precautions for Server and Network Products

In addition to the general precautions described earlier in this section, be sure to observe the following precautions when operating server and network products. Failure to observe these precautions could result in fire, bodily injury, and damage to the equipment.

### Safety interlocks and enclosures

To prevent access to areas containing hazardous energy levels, some servers are provided with enclosures and safety interlocks. Many Compaq servers are interlocked so that the power supply is disabled when the enclosure cover is removed. For servers provided with safety interlocks, observe the following precautions:

- ◆ Do not remove enclosure covers or attempt to defeat the safety interlocks.
- ◆ Do not repair accessories and options inside enclosed or interlocked areas of the system. Repair should be performed only by individuals who are qualified in servicing computer equipment and trained to deal with products capable of producing hazardous energy levels.

---

### **Accessories and options**

Installation of accessories and options in safety interlocked areas should be performed only by individuals who are qualified in servicing computer equipment and trained to deal with products capable of producing hazardous energy levels.

### **Products with casters**

Products provided with casters should be moved with care. Quick stops, excessive force, and uneven surfaces may cause the product to overturn.

### **Hot-pluggable power supplies**

Observe the following guidelines when connecting and disconnecting power to the power supplies:

- ◆ Install the power supply before connecting the power cord to the power supply.
- ◆ Unplug the power cord before removing the power supply from the server.
- ◆ If the system has multiple sources of power, disconnect power from the system by unplugging all power cords from the power supplies.

### **Floor standing products**

Be sure the bottom stabilizers on the equipment are installed and fully extended. Ensure that the equipment is properly stabilized and supported before installing options and cards.

### **Rack-mountable products**

Because the rack allows you to stack computer components vertically, you must take precautions to provide for rack stability and safety:

- ◆ Do not move large racks by yourself. Due to the height and weight of the rack, Compaq recommends a minimum of two people to accomplish this task.
- ◆ Before working on the rack, be sure the leveling jacks (feet) extend to the floor and that the full weight of the rack rests on the floor. Also install stabilizing feet on a single rack or join multiple racks together before starting work.
- ◆ Always load the rack from the bottom up, and load the heaviest item in the rack first. This makes the rack bottom-heavy and helps prevent the rack from becoming unstable.
- ◆ Ensure that the rack is level and stable before extending a component from the rack.

- 
- ◆ Extend only one component at a time. The rack may become unstable if more than one component is extended.
  - ◆ Use caution when pressing the component rail release latches and sliding a component into the rack. The slide rails could pinch your fingers.
  - ◆ Do not overload the AC supply branch circuit that provides power to the rack. The total rack load should not exceed 80% of the branch circuit rating.

### **Precautions for Products with External Television Antenna Connectors**

In addition to the general precautions described earlier in this section, be sure to observe the following precautions when using external television antennas with your product. Failure to observe these precautions could result in fire, bodily injury, and damage to the equipment.

#### **Compatibility**

Compaq television tuner cards with antenna connections should be used only with Compaq personal computers that are intended for home use.

#### **External television antenna grounding**

If an outside antenna or cable system is connected to the product, be sure the antenna or cable system is electrically grounded to protect against voltage surges and built-up static charges. Article 810 of the National Electrical Code, ANSI/NFPA 70, provides information about proper electrical grounding of the mast and supporting structure, grounding of the lead-in wire to an antenna discharge unit, size of grounding conductors, location of antenna-discharge unit, connection to grounding electrodes, and requirements for the grounding electrode.

#### **Lightning protection**

To protect a Compaq product during a lightning storm or when it will be unattended and unused for long periods of time, unplug the product from the electrical outlet and disconnect the antenna or cable system. This prevents damage to the product due to lightning and power line surges.

#### **Power lines**

Do not place an outside antenna system in the vicinity of overhead power lines or other electric light or power circuits, or where it can fall into power lines or circuits. When installing an outside antenna system, take extreme care to avoid touching power lines or circuits, as contact with them could be fatal.

---

## Antenna Grounding

This reminder is provided to call the CATV (cable television) system installer's attention to Section 820-40 of the NEC (National Electrical Code), which provides guidelines for proper grounding and, in particular, specifies that the cable ground shall be connected to the grounding system of the building, as close to the point of cable entry as practical.

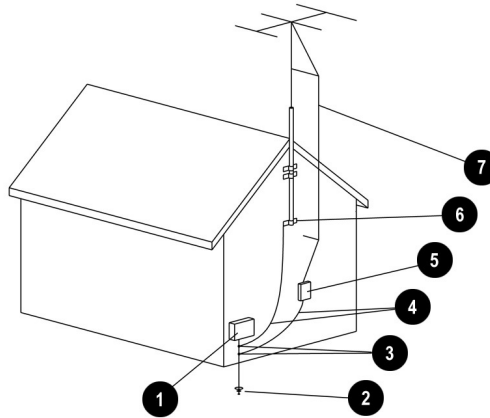

**Antenna Grounding**

No.	Component
①	Electric Service Equipment
②	Power Service Grounding Electrode System (NEC Art 250, Part H)
③	Ground Clamps
④	Grounding Conductors (NEC Section 810-21)
⑤	Antenna Discharge Unit (NEC Section 810-20)
⑥	Ground Clamp
⑦	Antenna Lead-in Wire

---

**Precautions for Products with Modems, Telecommunications, or Local Area Network Options**

**IMPORTANT SAFETY INSTRUCTIONS**

When using this device, basic safety precautions should always be followed to reduce the risk of fire, electric shock and injury to persons, including the following:

- ◆ Do not use this product near water, for example, near a bath tub, wash bowl, kitchen sink or laundry tub, in a wet basement or near a swimming pool.
- ◆ Avoid using this product during an electrical storm. There may be a remote risk of electric shock from lightning.
- ◆ Do not use this product to report a gas leak in the vicinity of the leak.
- ◆ Always disconnect the modem cable before opening the equipment enclosure or touching an uninsulated modem cable, jack or internal component.
- ◆ If this product was not provided with a telephone line cord, use only No. 26 AWG or larger telecommunication line cord in order to reduce the risk of fire.
- ◆ Do not plug a modem or telephone cable into the Network Interface Card (NIC) receptacle.

**Precautions for Products with Laser Devices**

All Compaq systems equipped with a laser device comply with safety standards, including International Electrotechnical Commission (IEC) 825. With specific regard to the laser, the equipment complies with laser product performance standards set by government agencies for a Class 1 laser product. The product does not emit hazardous light; the beam is totally enclosed during all modes of customer operation and maintenance.

**Laser Safety Warnings**

In addition to the general precautions described earlier in this section, be sure to observe the following warnings when operating a product equipped with a laser device. Failure to observe these warnings could result in fire, bodily injury, and damage to the equipment.



**WARNING:** To reduce the risk of exposure to hazardous radiation:

- ◆ Do not try to open the unit enclosure. There are no user-serviceable components inside.
- ◆ Do not operate controls, make adjustments, or perform procedures to the laser device other than those specified herein.
- ◆ Allow only Compaq Authorized Service technicians to repair the unit.

---

### **Compliance with CDRH Regulations**

The Center for Devices and Radiological Health (CDRH) of the U.S. Food and Drug Administration implemented regulations for laser products on August 2, 1976. These regulations apply to laser products manufactured from August 1, 1976. Compliance is mandatory for products marketed in the United States.

### **Compliance with International Regulations**

All Compaq systems equipped with a laser device comply with appropriate safety standards including IEC 825 and IEC 950.

### **Laser Product Label**

The following label or equivalent is located on the surface of your laser device. This label indicates that the product is classified as a CLASS 1 LASER PRODUCT.



### **Laser information**

Laser Type	Semiconductor GaAlAs
Wave Length	780 nm + / - 35 nm
Divergence Angle	53.5 degrees + / - 0.5 degrees
Output Power	Less than 0.2 m W or 10,869W m <sup>-2</sup> sr <sup>-1</sup>
Polarization	Circular 0.25
Numerical Aperture	0.45 inches + / - 0.04 inches

---

## For More Information

If you want more information about arrangement of work space and equipment or safety standards, consult the following references:

“American National Standard for Human Factors Engineering of Visual Display Terminal Workstations,” ANSI/HFS Standard No. 100-1988. Human Factors Society, Inc., P.O. Box 1369, Santa Monica, CA 90406.

*Working Safely with Your Computer.* Washington, D.C.: National Safety Council, 1991.

Or write to:

### **American National Standards Institute**

11 West 42nd St.  
New York, NY 10036  
TEL: (212) 642-4900  
FAX: (212) 398-0023  
<http://www.ansi.org>  
EMAIL: [info@ansi.org](mailto:info@ansi.org)

### **National Institute for Occupational Safety and Health (NIOSH)**

NIOSH Publications  
4676 Columbia Pkwy, MS C-13  
Cincinnati, OH 45226-1998  
TEL: (800) 356-4674  
FAX: (513) 533-8573  
<http://www.cdc.gov/niosh/homepage.html>  
EMAIL: [pubstaft@cdc.gov](mailto:pubstaft@cdc.gov)

### **Human Factors and Ergonomics Society**

ANSI/HFS 100-1988 Standard  
P.O. Box 1369  
Santa Monica, CA 90406-1369  
TEL: (310) 394-1811  
FAX: (310) 394-2410  
<http://hfes.org>  
EMAIL: [hfes@compuserve.com](mailto:hfes@compuserve.com)

---

### **International Standards Organization (ISO)**

Central Secretariat  
International Organization for Standardization  
1, rue de Varembe  
Case postale 56  
CH-1211 Genève 20, Switzerland  
TEL: +41 22 749 01 11  
FAX: +41 22 733 34 30  
<http://www.iso.ch>  
<http://www.iso.ch/infoe/stbodies.html>  
EMAIL: [central@iso.ch](mailto:central@iso.ch)

### **National Safety Council Library**

1121 Spring Lake Dr.  
Itasca, IL 60143-3201  
TEL: (630) 775-2199  
FAX: (630) 285-0242  
<http://www.nsc.org>  
EMAIL: [bob-nsc@dupagels.lib.il.us](mailto:bob-nsc@dupagels.lib.il.us)

### **Occupational Safety and Health Administration (OSHA)**

Publications Office  
U.S. Department of Labor  
200 Constitution Ave. NW, Room N3101  
Washington, DC 20210  
<http://www.osha.gov>  
<http://www.osha-slc.gov/ergo>  
<http://www.osha.gov/oshpubs/oshapubs>

### **TCO Information Center**

150 North Michigan Ave., Suite 1200  
Chicago, IL 60601-7594  
TEL: (312) 781-6223  
FAX: (312) 346-0683  
<http://www.tco-info.com/chicago.html>  
EMAIL: [info@tco-info.com](mailto:info@tco-info.com)





# Government Approvals

## European Union Notice



Products with the CE marking comply with the EMC Directive (89/336/EEC) and the Low Voltage Directive (73/23/EEC) issued by the Commission of the European Community and if this product has telecommunication functionality, the R&TTE Directive (1999/5/EC).

Compliance with these directives implies conformity to the following European Norms (the equivalent international standards and regulations are in parentheses):

- ◆ EN 55022 (CISPR 22) - Electromagnetic Interference
- ◆ EN 60950 (IEC 60950) - Product Safety
- ◆ EN 50082-1 (IEC 801-2, IEC 801-3, IEC 801-4) - Electromagnetic Immunity
- ◆ EN 60555-2 (IEC 555-2) - Power Line Harmonics

---

## Federal Communications Commission Notice

This equipment has been tested and found to comply with the limits for a Class B digital device pursuant to Part 15 of the FCC Rules. These limits are designed to provide reasonable protection against harmful interference in a residential installation. This equipment generates, uses, and can radiate radio frequency energy and, if not installed and used in accordance with the instructions, may cause harmful interference to radio communications. However, there is no guarantee that interference will not occur in a particular installation. If this equipment does cause harmful interference to radio or television reception (which can be determined by turning the equipment off and on), the user is encouraged to try to correct the interference by one or more of the following measures:

- ◆ Reorient or relocate the receiving antenna.
- ◆ Increase the separation between the equipment and the receiver.
- ◆ Connect the equipment into an outlet on a circuit different from that to which the receiver is connected.
- ◆ Consult the dealer or an experienced radio or television technician for help.

### **Modifications**

The FCC requires the user to be notified that any changes or modifications made to this device that are not expressly approved by Compaq Computer Corporation may void the user's authority to operate the equipment.

### **Cables**

Connections to this device must be made with shielded cables with metallic RFI/EMI connector hoods in order to maintain compliance with FCC Rules and Regulations.

---

## Declaration of Conformity for Products Marked with the FCC Logo (United States Only)

This device complies with Part 15 of the FCC Rules. Operation is subject to the following two conditions: (1) this device may not cause harmful interference, and (2) this device must accept any interference received, including interference that may cause undesired operation.

For questions regarding your product, call 800.652.6672 (800.OK.COMPAQ) or contact:

Compaq Computer Corporation  
P.O. Box 692000, Mail Stop 530113  
Houston, Texas 77269-2000

For questions regarding this FCC declaration, call 281.514.3333 or contact:

Compaq Computer Corporation  
P.O. Box 692000, Mail Stop 510101  
Houston, Texas 77269-2000

To identify this product, refer to the Part, Series, or Model number found on the product.

**Canadian Notice** This Class B digital apparatus meets all requirements of the Canadian Interference-Causing Equipment Regulations.

**Avis Canadien** Cet appareil numérique de la classe B respecte toutes les exigences du Règlement sur le matériel brouilleur du Canada.

### Japanese Notice

この装置は、情報処理装置等電波障害自主規制協議会（VCCI）の基準に基づくクラスB情報技術装置です。この装置は、家庭環境で使用することを目的としていますが、この装置がラジオやテレビジョン受信機に近接して使用されると、受信障害を引き起こすことがあります。  
取扱説明書に従って正しい取り扱いをして下さい。

---

## Telecommunications Device Approvals

The telecommunications device in your computer is approved for connection to the telephone network in the countries whose approval markings are indicated on the product label located on the bottom of the computer or on the modem.

Refer to the documentation included with the product to ensure the product is configured for the country in which it is located. Selecting a country other than the one in which the product is located may cause your modem to be configured in a way that violates the telecommunication regulations/laws of that country. In addition, your modem may not function properly if the correct country selection is not made. If when selecting a country a message appears that states that the country is not supported, this means that the modem has not been approved for use in this country and thus should not be used.

## U.S. Modem Regulatory Statements

This equipment complies with Part 68 of the FCC rules. Located on the bottom of the computer or on the modem is a label that contains, among other information, the FCC certification number and ringer equivalence number (REN) for this equipment. If requested, this information must be provided to the telephone company.

**Applicable  
certification  
jack  
USOC = RJ11C**

An FCC compliant telephone cord, and a modular plug are provided with this equipment. This equipment is designed to be connected to the telephone network or premises wiring using a compatible modular jack which is Part 68 compliant. See installation instructions for details.

The Ringer Equivalence Number (REN) is used to determine the quantity of devices which may be connected to the telephone line. Excessive RENs on the telephone line may result in the devices not ringing in response to an incoming call. Typically, the sum of the RENs of all devices connected to one line should not exceed five (5.0). To be certain of the number of devices that may be connected to a line (as determined by the total RENs) contact the local telephone company.

If this Compaq equipment causes harm to the telephone network, the telephone company will notify you in advance that temporary discontinuance of service may be required. But, if advance notice is not practical, the telephone company will notify the customer as soon as possible. You will also be advised of your right to file a complaint with the FCC if you believe it is necessary.

---

The telephone company may make changes to its facilities, equipment, operations or procedures that could affect the operation of the equipment. If this happens, the telephone company will provide advance notice in order for you to make necessary modifications to maintain uninterrupted telephone service.

If trouble is experienced with this Compaq equipment, call Compaq at 1-800-OK-COMPAQ or 1-800-652-6672. If the equipment is causing harm to the telephone network, the telephone company may request that you disconnect the equipment until the problem is resolved. You should only perform repairs to the equipment specifically discussed in the Troubleshooting section of the user guide, if one is provided.

Connection to party line service is subject to state tariffs. Contact the state public utility commission, public service commission or corporation commission for information.

The Telephone Consumer Protection Act of 1991 makes it unlawful for any person to use a computer or other electronic device, including fax machines, to send any message unless such message clearly contains in a margin at the top or bottom of each transmitted page or on the first page of the transmission, the date and time it is sent and an identification of the business or other entity, or other individual sending the message and the telephone number of the sending machine or such business, other entity, or individual. The telephone number provided may not be a 900 number or any other number for which charges exceed local or long-distance transmission charges.

In order to program this information into your fax machine, you should complete the steps outlined in the faxing software instructions.

These requirements apply to all fax machines and have been extended to all fax modems manufactured on or after December 13, 1995.

---

## Canadian Modem Regulatory Statements

**Notice:** The Industry Canada label identifies certified equipment. This certification means that the equipment meets telecommunication network protective, operational, and safety requirements as prescribed in the appropriate Terminal Equipment Technical Requirements document(s). The Department does not guarantee the equipment will operate to the user's satisfaction.

Before installing this equipment, users should ensure that it is permissible to be connected to the facilities of the local telecommunications company. The equipment must also be installed using an acceptable method of connection. The customer should be aware that compliance with the above conditions may not prevent degradation of service in some situations.

Repairs to certified equipment should be coordinated by a representative designated by the supplier. Any repairs or alterations made by the user to this equipment, or equipment malfunctions, may give the telecommunications company cause to request the user to disconnect the equipment.

Users should ensure for their own protection that the electrical ground connections of the power utility, telephone lines and internal metallic water pipe system, if present, are connected together. This precaution may be particularly important in rural areas.



**CAUTION:** Users should not attempt to make such connections themselves, but should contact the appropriate electric inspection authority, or electrician, as appropriate.

**Notice:** The **Ringer Equivalence Number** (REN) assigned to each terminal device provides an indication of the maximum number of terminals allowed to be connected to a telephone interface. The termination on an interface may consist of any combination of devices subject only to the requirement that the sum of the Ringer Equivalence Numbers of all the devices does not exceed 5. The Ringer Equivalence Number for this device is 1.0.

---

## U.K. BABT Users Notice

### (SupraExpress 56i Pro Global Modem - Desktop Products Only)

The modem is intended for only use in the Compaq Internet PC. For the purposes of BABT approval, the modem is classified as a host-independent product.

### Telephone Network Connection

The modem is suitable for connection to the Public Switched Telephone Network (PSTN) direct exchange lines and relevant branch systems (PBXs).

A ringer equivalent number (REN) is a value given to all apparatus to be connected to the PSTN. Its value can be taken and used to calculate the maximum number of equipment items that can be connected in parallel without impairing the performance of the standard bell circuit.

1.  $REN = 3/n$  where  $n$  is the maximum number of units that may be used in parallel.
2. The maximum REN of a line is 4; therefore, the total REN of all apparatus connected to the line (obtained by summing the individual REN values) should not exceed 4. This value includes any BT provided instrument, each of which is assumed to have REN value of 1.0 unless otherwise stated. Exceeding the REN value of 4 may cause your telephone(s) to ring weakly or not ring at all.
3. Only one modem should be connected to a telephone line. Connecting a modem in parallel with one or more telephone instruments is not allowed.
4. The REN for this piece of equipment is 0.8.
5. The exchange should provide facilities for either loop disconnect (pulse) dialing or multi frequency (tone) dialing. The modem can be configured to operate with either system.
6. During dialing, this apparatus may tinkle the bells of other telephones using the same line. This is not a fault, and we advise you not to call the Fault Repair Service.
7. The modem specified in this guide is for the Compaq Internet PC.



- 
8. This apparatus has been approved for the following facilities:
- ❖ Connection to direct exchange lines providing DTMF signaling
  - ❖ Connection to compatible PBXs providing DTMF signaling
  - ❖ Operation in the absence of proceed indication, selectable by user
  - ❖ Call progress monitoring functions
  - ❖ Data modem functions
  - ❖ Auto-dialing functions
  - ❖ Auto-answering functions

Any other usage will invalidate the approval of the apparatus, if as a result, it then ceases to conform to the standards against which approval was granted.

All apparatus connected to this modem, and thereby connected directly or indirectly to the British Telecom Public Switched Telephone Network, must be approved apparatus as defined in Section 22 of the British Telecommunications Act of 1984.

Although this equipment can use either loop disconnect or DTMF signaling, only the performance of the DTMF signaling is subject to regulatory requirements for correct operation. It is therefore strongly recommended that the equipment is set to use DTMF signaling for access to public or private emergency services. DTMF signaling also provides faster call set up.

The modem may not be used on extension wiring that makes use of plug pins 1 and 6. If in doubt, advice must be obtained from a competent telecommunications engineer.

Difficulties may occasionally be experienced from other apparatus connected to the BT PSTN via the modem apparatus. Such difficulties may include the following:

- ◆ difficulty in making calls
- ◆ problems in telephone conversion being experienced by both parties to the call

Initially, normal operation will be possible. However, changes to or modernization of the network (taking place in the normal course of events) may result in the apparatus being connected to a network service with which it was not designed to be compatible. Failure of the apparatus to work under these circumstances may not be the responsibility of the network operator.

If these difficulties occur, contact your product supplier or your Compaq-authorized reseller in the United Kingdom.

This device is intended for auto-answering of incoming calls. Under normal conditions, callers will be accustomed to calls being answered within 10 seconds, and a majority of callers will abandon calls that are not answered within 45 seconds.

---

Several options are available for auto-answering operation. The default setting is for two incoming rings. This is the recommended setting for normal operation by most computer users.

**Auto Dialing with the Modem** When entering telephone numbers, ensure that the number that appears on the screen is correct before beginning to dial.

## Benutzerhinweise für besondere Bestimmungen in Österreich

**Hinweis für die Benutzung in osterreich** Sofern Sie das SupraExpress 56i Pro global modem an einer Nebenstellenanlage benutzen wollen, erkundigen Sie sich bitte bei Ihrem Fachhändler nach der Möglichkeit, die Amtsholung einzustellen.

**Wahlsperre** Ein Modem darf, beispielsweise im „unbeaufsichtigten Betrieb“, nicht pausenlos dieselbe Rufnummer anwählen (Wahlsperre).

Nach zwölf erfolglosen Wählversuchen innerhalb einer Stunde gibt das Modem die Meldung „BLACK-LISTE“ (Wahlsperre) aus. Danach ist jeder weitere Wählversuch blockiert.

Die Wahlsperre wird wieder aufgehoben, wenn eines der drei folgenden Ereignisse eintritt:

- ◆ Sie starten den Computers neu (reboot), oder
- ◆ Ablauf einer Stunde, oder
- ◆ Sie erhalten einen Anruf.

## Benutzerhinweise für besondere Bestimmungen in Deutschland

**Hinweis für die Benutzung in der Bundesrepublik Deutschland** Dieses Gerät ist mit einem mindestens 4-adrigen Anschlußkabel mit TAE-Stecker mit **Kodierung N** ausgestattet und verfügt über weiterführende Sprechadern. Es kann als einzige Endeinrichtung oder mit weiteren Endeinrichtungen am Netzanschluß betrieben werden.

Weitere Endeinrichtungen, die sich an dem Telefonanschluß befinden, werden beim Einstecken des Gerätes nicht von der Leitung getrennt. Der Stecker kann nur in N-Hkodierte Anschlußdosen gesteckt werden.

---

## Bruggerinstruktioner i overensstemmelse med danske krav

**Opkaldskoder P og T** Compaq-modemet SupraExpress 56i Pro global modem understøtter ikke impulssignalering. Både opkaldskode P (impulssignalering) og T (tonesignalering) tvinger modemmet til at anvende tonesignalering.

## Speciale gebruiksinstructies voor Nederland

- Aansluitfactor**
1. Het modem is geschikt voor aansluiting op het openbare geschakelde telefoonnetwerk en op (analoge) telefooncentrales binnen bedrijven en instellingen.
  2. De aansluitfactor is een waarde die wordt toegekend aan alle apparaten die op het openbare telefoonnetwerk kunnen worden aangesloten. Met deze waarde kan worden berekend hoeveel apparaten maximaal parallel kunnen worden geschakeld. De maximale aansluitfactor van een lijn is 5. De aansluitfactor van alle apparaten die zijn aangesloten op één lijn mag daarom nooit hoger zijn dan 5. U berekent de aansluitfactor door de waarden van de afzonderlijke apparaten op te tellen.
  3. De aansluitfactor voor dit apparaat is 1,0.

**Wachten op kiestoon** Het modem moet altijd eerst een kiestoon ontvangen voordat wordt geprobeerd een verbinding tot stand te brengen. Deze vereiste kan niet worden uitgeschakeld met de opdracht ATX<n>.

**Handenvrij bellen** Handenvrij bellen is toegestaan bij gebruik van een aparte (goedgekeurde) telefoon set.

## Användarinstruktioner i överensstämmelse med svenska krav

### Uppringningskod P och T

Modemet till SupraExpress 56i Pro global modem stödjer inte pulssignalering. Både uppringningskod P (pulssignalering) och T (tonsignalering) är jämförbara och vill tvinga modemmet att använda tonsignalering.

---

## New Zealand Modem Regulatory Statements

The grant of a Telepermit for any item of terminal equipment indicates only that Telecom has accepted that the item complies with minimum conditions for connection to its network. It indicates no endorsement of the product by Telecom, nor does it provide any sort of warranty. Above all, it provides no assurance that any item will work correctly in all respects with another item of Telepermitted equipment of a different make or model, nor does it imply that any product is compatible with all of Telecom's network services.

This equipment is not capable, under all operating conditions, of correct operation at the higher speeds for which it is designed. Telecom will accept no responsibility should difficulties arise in such circumstances.

If this device is equipped with pulse dialing, note that there is no guarantee that Telecom lines will always continue to support pulse dialing.

Use of pulse dialing, when this equipment is connected to the same line as other equipment, may give rise to bell tinkle or noise and may also cause a false answer condition. Should such problems occur, the user should not contact the Telecom Faults Service.

This equipment may not provide for the effective hand-over of a call to another device connected to the same line.

Some parameters required for compliance with Telecom's Telepermit requirements are dependent on the equipment (PC) associated with this device. The associated equipment shall be set to operate within the following limits for compliance with Telecom's Specifications:

1. There shall be no more than 10 call attempts to the same number within any 30 minute period for any single manual call initiation, and
2. The equipment shall go on-hook for a period of not less than 30 seconds between the end of one attempt and the beginning of the next attempt.

Where automatic calls are made to different numbers, the equipment shall be set to go on-hook for a period of not less than 5 seconds between the end of one attempt and the beginning of the attempt.

The equipment shall be set to ensure that calls are answered between 3 and 30 seconds of receipt of ringing (S0 set between 2 and 10).

---

## Voice Support

All persons using this device for recording telephone conversations shall comply with New Zealand law. This requires that at least one part to the conversation is that it is being recorded. In addition, the Principles enumerated in the Privacy Act 1993 shall be complied with in respect to the nature of the personal information collected, the purpose for its collection, how it is to be used and what is disclosed to any other party.

This equipment shall not be set to make automatic calls to the Telecom “111” Emergency Service.

## Safety

Safety is important when you are operating your computer. Follow the guidelines in this section to enjoy your computing experience.

### Batteries

For information about real-time clock battery replacement, contact your Compaq-authorized dealer, reseller, or service provider.



**WARNING:** Your computer is provided with a battery-powered, real-time clock circuit. Danger of explosion and risk of personal injury exists if the battery is incorrectly replaced or mistreated. Do not attempt to recharge the battery, disassemble it, remove it, immerse it in water, or dispose of it in fire.



**WARNING:** This computer may contain a lithium-ion or nickel-metal-hydride battery pack. There is a risk of fire and chemical burn if the battery pack is handled improperly. Do not disassemble, crunch, puncture, or short external contacts, dispose of in water or fire, or expose to temperatures higher than 140°F (60°C).



**CAUTION:** Do not dispose of batteries with general household waste. To dispose of them or recycle them, use the public collection system in accordance with local regulations or return them to Compaq, an authorized Compaq Partner, or the point-of-sale. In North America, dispose of nickel-metal-hydride or lithium-ion batteries by taking advantage of the Compaq battery recycling program. You will be provided with a postage-paid battery pack mailer pre-addressed to a reclamation facility where the metals are recycled.

### Power Cords

If you were not provided with a power cord for your computer or for an AC power accessory intended for use with your computer, you should purchase a power cord that is approved for use in your country.

---

The power cord must be rated for the product and for the voltage and current marked on the product's electrical ratings label. The voltage and current rating of the cord should be greater than the voltage and current rating marked on the product.

In addition, the diameter of the wire must be a minimum of 0.75 mm<sup>2</sup>/18 AWG, and the length of the cord must be between 5 feet (1.5 m) and 6.5 feet (2 m). If you have questions about the type of power cord to use, contact your Compaq-Authorized Service Provider.

A power cord should be routed so that it is not likely to be walked on or pinched by items placed upon it or against it. Particular attention should be paid to the plug, electrical outlet, and the point where the cord exits from the product.

**Laser  
Assemblies**

All Compaq systems equipped with CD drives comply with appropriate safety standards including IEC 825. In addition, the equipment complies with laser product performance standards set by government agencies as a Class 1 laser product. The equipment does not emit hazardous radiation; the beam is totally enclosed during all modes of customer operation and maintenance.

**CDRH  
Regulations**

The Center for Devices and Radiological Health (CDRH) of the U.S. Food and Drug Administration implemented regulations for laser products on August 2, 1976. These regulations apply to laser products manufactured since August 1, 1976. Compliance is mandatory for products marketed in the United States.



**WARNING:** Use of controls or adjustments or performance of procedures other than those specified in your Compaq documentation set may result in hazardous radiation exposure.

---

The CD drive is classified as a Class 1 laser product. This label is located on the outside of the CD drive:



*Figure A-1. Laser Label*

Laser Label Information	
Laser Type	Semiconductor GaAlAs
Wavelength	650-780 +/- 35 nm
Divergence Angle	53.5 Degree +/- 5 Degree
Output Power	Less than 0.2 mW or 10.869 W/m <sup>2</sup> sr
Polarization	Circular
Numerical Aperture	0.45 +/- 0.04



**WARNING:** Only authorized technicians trained by Compaq should attempt to repair this equipment. All troubleshooting and repair procedures are detailed to allow only subassembly/module-level repair. Because of the complexity of the individual boards and subassemblies, no one should attempt to make repairs at the component level or to make modifications to any printed wiring board. Improper repairs can create a safety hazard.

---

## Using the Computer



**WARNING:** A very small portion of the population may experience epileptic seizures when viewing certain kinds of flashing lights or patterns that are commonly present in our daily environment. These persons may experience seizures while watching some kinds of television pictures or playing certain games, including games played on the Internet PC. Players who have not had any previous seizures may nonetheless have an undetected epileptic condition. Consult your physician if you experience any of the following symptoms while playing games: altered vision, muscle twitching, other involuntary movements, loss of awareness of your surroundings, mental confusion, or convulsions.



**WARNING:** Some studies have suggested that long periods of typing, improper workstation setup, incorrect work habits, or problems in your personal health may be linked to discomfort or serious injuries. Refer to your *Safety & Comfort Guide* for more information about choosing a workspace and creating a comfortable work environment.

## German Ergonomics Notice

These products are not intended for continuous use in an office environment.

## Mobile Products – German Ergonomics Notice

The Compaq Agency Series 2940, CM2000, CM2010, and CM2030 family of notebook computers bearing the “GS” approval mark meet the requirements of ZH1/618 (German Safety Regulations for Display Work Places in the Office Sector) when used in conjunction with port replicators, keyboards, and monitors that also bear the “GS” mark.

These notebook computers are not intended for continuous use in an office environment.

## Locating the Regulatory Compliance Markings Labels

Other labels containing safety or regulatory information about your specific computer are located on the inside and outside of your computer. The following illustrations show typical Regulatory Compliance Markings labels that apply to your Compaq personal computer. Compliance Agency labels are located on the back of the computer. For examples of typical agency labels, refer to the Safety section.



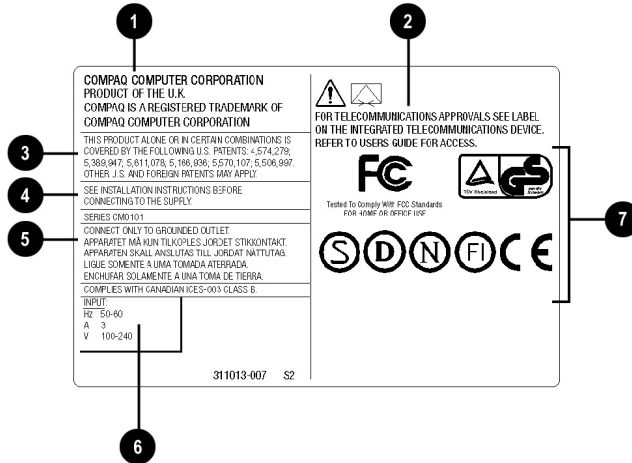

**Typical Agency Label**

No.	Component
①	Manufacturing Site
②	Modem Regulation Statement
③	Patent Information
④	Power Supply Caution
⑤	Grounding Information
⑥	Voltage Ratings
⑦	Agency Approvals

1 — **COMPAQ COMPUTER CORPORATION**  
 PRODUCT OF SINGAPORE  
 COMPAQ IS A REGISTERED TRADEMARK OF  
 COMPAQ COMPUTER CORPORATION

2 — THIS PRODUCT ALONE OR IN CERTAIN COMBINATIONS IS  
 COVERED BY THE FOLLOWING U.S. PATENTS: 4,574,279;  
 5,611,078; 5,166,936; 5,389,947; 5,570,107; 5,125,088;  
 5,506,997. OTHER U.S. AND FOREIGN PATENTS MAY APPLY.

3 — SEE INSTALLATION INSTRUCTIONS BEFORE  
 CONNECTING TO THE SUPPLY.  
 SERIES CM1000

4 — CONNECT ONLY TO GROUNDED OUTLET.  
 APPARATET MÅ KUN TILKOPLES JORDET STIKKONTAKT.  
 APPARATEN SKALL ANSLUTAS TILL JORDAT NÄTTUTAG.  
 LIGUE SOMETE A UMA TOMADA ATERRADA.  
 ENCHUFAR SOLAMENTE A UNA TOMA DE TIERRA.  
 COMPLIES WITH CANADIAN ICES-003 CLASS B.

5 — INPUT:  
 Hz 50-60  
 A 5/2.5  
 V 100-120/200-240~

6 — **FC**  
 Tested To Comply With FCC Standards  
 FOR HOME OR OFFICE USE

7 — **SF** LR 56895C  
**UL** 63H0 LISTED ITE E77477  
**CE**  
**S** **D** **N** **FI**  
**TUV** PRODUCT SERVICE **GS** **NOM** **NYCE**  
 971144-00 **VCI** **V**  
 N119  
  
 FOR TELECOMMUNICATIONS APPROVALS SEE LABEL  
 ON THE INTEGRATED TELECOMMUNICATIONS DEVICE.  
 REFER TO USERS GUIDE FOR ACCESS.

334583-003 S3

No.	Component
1	Manufacturing Site
2	Modem Regulation Statement
3	Patent Information
4	Power Supply Caution
5	Grounding Information
6	Voltage Ratings
7	Agency Approvals

**Typical Agency Label**

---

## Energy Compliance



Agency labels are on the back of the computer. For examples of typical agency labels, refer to the Safety section.

### Energy Star Compliance

The Energy Star logo is your assurance that your computer is in compliance with the EPA Energy Star Computers Program 2.0 guidelines for energy efficiency. Your computer may not meet these guidelines if it is not marked with the Energy Star logo.

Compaq Internet PC products marked with the Energy Star Logo are compliant with Energy Star Computers Program 2.0 standard of the U.S. Environmental Protection Agency (EPA). The EPA Energy Star Logo does not imply endorsement by the EPA. As an Energy Star Partner, Compaq Computer Corporation has determined that products marked with the Energy Star Logo meet the Energy Star guidelines for energy efficiency.

The Energy Star Computers Program was created by the EPA to promote energy efficiency and reduce air pollution through more energy-efficient equipment in homes, offices, and factories. Compaq products achieve this standard by reducing power consumption when not being used. Instructions for using the energy saving features of your computer are located in the power management section of the documentation that came with your computer.

The power management feature of your computer is supported when used with the following operating system: Microsoft Windows Operating System.

The power management feature, when used in conjunction with an external Energy Star compliant monitor, will support the power-down features of the monitor. The power management feature allows an external monitor to go into low-power mode when the screen saver timeout occurs. To take advantage of these energy savings, the monitor's power management feature has been preset to power down the monitor after a period of system inactivity. Refer to the power management section of the documentation that came with your computer for instructions on modifying or disabling this feature.



**CAUTION:** Using the Energy Save Monitor feature with non-Energy Star compliant monitors may cause video distortion when the screen saver timeout occurs.



**CAUTION:** The power management feature is not compatible with some non-Compaq bus-mastering ISA devices. Using the power management feature with some of these devices may cause errors when the system is placed in the low power state.