

Important Service Information

For the fastest path to the right answers, go to www.compaq.com/consumersupport.

At this site you will find online services to assist with your hardware and software related questions, issues, and product needs.

Compaq offers the following online services for your Presario product:

- Drivers & Updates - find original drivers, latest updates, and software fixes for your Presario desktop or mobile product
- Compaq Customer Communities - where users ranging from novices to technical experts collaborate to share knowledge, information, and assistance
- Ask.Compaq - search the Compaq frequently asked question and answer database
- E-mail a Support Specialist - escalate your request for product service online to a qualified Compaq support specialist

When escalating a service event online, it is important to include the following information in your inquiry. Please take a moment to write down the following information for your future reference.

- **Product Name:** _____
- **Model Name:** _____
- **Serial Number:** _____
- **Date of Purchase:** _____

Notice

© 2001 Compaq Computer Corporation

COMPAQ and the Compaq logo Registered in U.S. Patent and Trademark Office.

Microsoft and Windows are trademarks of Microsoft Corporation.

All other product names mentioned herein may be trademarks or registered trademarks of their respective companies.

Compaq shall not be liable for technical or editorial errors or omissions contained herein.

The information in this document is subject to change without notice.

The information in this publication is subject to change without notice and is provided "AS IS" WITHOUT WARRANTY OF ANY KIND. THE ENTIRE RISK ARISING OUT OF THE USE OF THIS INFORMATION REMAINS WITH RECIPIENT. IN NO EVENT SHALL COMPAQ BE LIABLE FOR ANY DIRECT, CONSEQUENTIAL, INCIDENTAL, SPECIAL, PUNITIVE OR OTHER DAMAGES WHATSOEVER (INCLUDING WITHOUT LIMITATION, DAMAGES FOR LOSS OF BUSINESS PROFITS, BUSINESS INTERRUPTION OR LOSS OF BUSINESS INFORMATION), EVEN IF COMPAQ HAS BEEN ADVISED OF THE POSSIBILITY OF SUCH DAMAGES. THE FOREGOING SHALL APPLY REGARDLESS OF THE NEGLIGENCE OR OTHER FAULT OF EITHER PARTY AND REGARDLESS OF WHETHER SUCH LIABILITY SOUNDS IN CONTRACT, NEGLIGENCE, TORT, OR ANY OTHER THEORY OF LEGAL LIABILITY, AND NOTWITHSTANDING ANY FAILURE OF ESSENTIAL PURPOSE OF ANY LIMITED REMEDY.

The limited warranties for Compaq products are exclusively set forth in the documentation accompanying such products. Nothing herein should be construed as constituting a further or additional warranty.

Compaq Presario
First Edition (May 2001)
Part Number 233700-001

Contents



Chapter 1 Introduction	1-1
Symbols and Graphics Used	1-2
Computer Illustrations and Features	1-2
Where Can I Find Information?	1-3
Warranty Certificate	1-3
Replacing Parts	1-3
Upgrading Your Computer	1-3
Safety.....	1-4
Safety and Comfort	1-4
How Do I Find Information on the CD-ROM?.....	1-5
Using the <i>My Presario—Learning More</i> CD	1-5
Chapter 2 Using Your Computer	2-1
Your Computer at a Glance	2-2
What’s in Front?	2-2
What’s in Back?	2-2
Keyboard Basics.....	2-3
Getting to Know the Standard Keyboard Keys	2-3

Keyboard Buttons	2-4
Using CD/DVD Control Buttons	2-4
Using Internet Zone Buttons	2-5
Customizing the Internet Zone Buttons	2-6
Using Quick Launch Web Buttons	2-7
Assigning the My Program Button	2-8
Adjusting the Volume	2-8
Putting Your Computer to Sleep	2-9
Waking Your Computer	2-9
System Status Lights	2-10
Understanding the System Status Lights	2-10
Smart Credit Card Internet Keyboard.....	2-11
Understanding the Smart Credit Card Internet Keyboard	2-11
Using the Smart Credit Card Feature	2-11
Compaq/Logitech™ Wireless Wheel Mouse.....	2-12
Installing the Wireless Wheel Mouse	2-12
Scroll Mouse and Wireless Mouse.....	2-13
Making Screen Selections	2-13
Opening Software and Files	2-13
Scrolling	2-13
Autoscrolling	2-14
Speakers.....	2-15
Turning on the Speakers	2-15

Disk, Hard Drive, CD-ROM, CD-RW, DVD-ROM, and DVD-R Drives	2-16
Using the Disk Drive	2-16
Using the Hard Drive	2-16
Inserting a CD into the CD-ROM, CD-RW, DVD-ROM, or DVD-R Drive	2-17
Removing a Disc from a Drive	2-18
Playing an Audio CD	2-18
Playing a DVD-ROM Movie	2-19
Creating Your Own CDs	2-20
Internet Video Camera	2-21
Using the Logitech QuickCam Internet Video Camera	2-21
Chapter 3 Welcome to the Web	3-1
Basic Concepts	3-2
What Is the Internet?	3-2
What Is a Hyperlink?	3-2
Compaq Connection Helper	3-3
Setting the Internet Buttons to AOL	3-3
Internet Connection	3-4
Connecting with AOL	3-4
Searching the Web Using AOL	3-4
E-mail	3-5
Setting Up Outlook Express E-mail	3-5
Typing an E-mail Message	3-5
Understanding E-mail Addresses	3-6
Sending an E-mail Using Outlook Express	3-7
Sending an E-mail Using AOL	3-8

Content Advisor	3-9
Reading Your Outlook Express E-mail Messages	3-9
Reading Your AOL E-mail Messages	3-9
Restricting Internet Content	3-10
Chapter 4 Common Tasks	4-1
Print Basics	4-2
Using the Menu to Print	4-2
Games and Digital Audio Files	4-3
Playing Games	4-3
Playing Digital Audio Files	4-3
Software	4-4
Installing Software from a CD, DVD, or Disk	4-4
Installing Software Downloaded from the Internet	4-5
Chapter 5 Computer Upgrades	5-1
Internal Components	5-2
Accessing Internal Computer Components	5-2
Upgrading Components	5-3
Upgrading the CD-ROM, CD-RW, and DVD-ROM Drives	5-3
Upgrading Computer Memory	5-5
Adding Components	5-6
Adding the Optional Hard Drive	5-6
Adding an Expansion or Option Card	5-8

Chapter 6 Need Some Help?	6-1
Helpful Hints.....	6-2
Recovery CD.....	6-3
Using the Recovery CD	6-3
Compaq Support.....	6-4
Troubleshooting	6-5
Audio	6-5
CD-ROM, CD-RW, or DVD-ROM	6-6
Disk Drive	6-7
Display (Monitor)	6-9
Hard Drive	6-10
Internet Access	6-11
Keyboard and Scroll Mouse	6-12
Wireless Wheel Mouse	6-14
Memory	6-15
Power	6-15
Index	Index-1

Introduction

1

In This Chapter

Symbols and Graphics Used, 1-2

Where Can I Find Information?, 1-3

Safety, 1-4

How Do I Find Information on the CD-ROM?, 1-5

Congratulations! As the owner of a new Compaq Internet PC, you have joined the worldwide community of Presario computer users. Once your computer is set up and connected to the Internet, you can explore vast regions of information, entertainment, and online services.



This guide is designed to help you:

- Get acquainted with computer features you'll want to try during the first few days or weeks.
- Keep your computer running smoothly by using the tools on your computer.
- Solve problems if they occur.

Symbols and Graphics Used

Warnings and cautions are displayed to protect you from injury, your equipment from damage, and your files from data loss.

The following words and symbols have special meaning in this guide and in the CD documentation:



Failure to follow directions may result in bodily harm or loss of life.

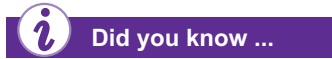

Understanding the background or concept may help you solve a problem.



Helpful hints make using your computer easier and faster.



Another document or another page in this document has related information.

▲ Caution: Failure to follow directions may result in damage to equipment or loss of data.

Computer Illustrations and Features

The computer illustrations shown and the features described in this guide may differ slightly from your Compaq Presario Internet PC.

Where Can I Find Information?

Information is available in several forms: printed documents, electronic documents on the CD that came with your computer, and the Compaq Web site. Use this guide as your first point of reference, and then refer to the following documents:

- Quick Set-Up poster
- Safety and Comfort flyer
- Warranty Certificate
- *My Presario—Learning More* CD
- Presario Newsletter
- *Getting Started: Microsoft Windows* manual



Did you know ...

The Compaq Web site is available worldwide. As you explore the Internet, go to the following address for information about products, services, and exciting activities:

www.compaq.com

Warranty Certificate

The warranty details Compaq's commitment to repair or replace parts during the warranty period and lists important Compaq telephone numbers. *In the event of a mechanical problem, contact Compaq, not the retailer who sold you the computer.*

Keep the warranty in a safe place for future reference.

Replacing Parts

The Easy Access design of your Internet PC allows you to access internal components—in most cases, without using any tools.

The *My Presario—Learning More* CD describes procedures for upgrading and replacing computer components. If you experience a problem and are unable to resolve the issue after referring to this guide and the *My Presario—Learning More* CD, contact Technical Support. If a replacement part is needed, the technician will send the replacement part with illustrated instructions for removing the factory-installed part and replacing it.

Upgrading Your Computer

Expand your Presario performance with upgrades like memory and additional peripherals, such as a digital camera and a printer. To learn more, visit the online store at:

www.compaq.com/athome

Safety

Your computer is an electrical device. Treat it with care to avoid personal injury and damage to the equipment.

Warning

To reduce the risk of electric shock and damage to the equipment, read the Safety and Comfort guide on the My Presario—Learning More CD before performing any procedures involving the internal components of your computer.

Did you know ...

For added protection during an electrical storm, perform a shutdown, then disconnect your computer (and all peripherals) from the power source (wall outlet). After shutting down your computer, unplug the surge protector(s) from the power source.

Don't forget to plug your surge protector(s) back in after the storm has passed.

Safety and Comfort

The *My Presario—Learning More* CD contains Safety and Comfort information on how to:

- Set up your work area for maximum comfort.
- Practice good posture, hand position, work habits, and health habits while using your computer.
- Use a grounding plug to prevent electrical shorts, shocks, or fires.
- Use a surge protector to regulate the flow of electricity to the computer, modem, and all peripherals, such as a printer, speakers, and monitor.
- Become static-free before removing the side panel.

How Do I Find Information on the CD-ROM?

The *My Presario—Learning More* CD has information on the following topics:

- Advanced features of your computer
- Solving computer problems
- Safety and comfort
- Compaq service and support
- Upgrading your computer
- Government regulatory information



Did you know ...

Electronic documents often have hyperlinks to help you find information quickly. When you pass the cursor over a hyperlink, a small hand is displayed. When you click a hyperlink, it jumps to the referenced page. Hyperlinks are represented by navigation buttons, colored text, and images.

Using the *My Presario—Learning More* CD

1. Insert the *My Presario—Learning More* CD into the CD-ROM drive. The CD will run automatically and the Startup screen will appear.

Note: If the CD does not run automatically, click the **Start** button, select **Run**, and type **E:autorun.exe** (where E represents the letter of your CD-ROM drive).

2. Hover the cursor over **Presario QuickTour** and click a subtopic to view the multimedia Presario QuickTour, or click the **Online Documentation** hyperlink to access the *My Presario—Learning More* guide and the *Safety & Comfort* guide.

3. On the Online Documentation page, hover your cursor over a topic to see a list of subtopics.
4. Click on a topic or subtopic to view its contents.



Using Your Computer

2

In This Chapter

Your Computer at a Glance, 2-2

Keyboard Basics, 2-3

Keyboard Buttons, 2-4

System Status Lights, 2-10

Smart Credit Card Internet Keyboard, 2-11

Compaq/Logitech™ Wireless Wheel Mouse, 2-12

Scroll Mouse and Wireless Mouse, 2-13

Speakers, 2-15

Disk, Hard Drive, CD-ROM, CD-RW, DVD-ROM, and DVD-R Drives, 2-16

Internet Video Camera, 2-21

In this chapter, you learn about the following exciting, easy-to-use features of your computer:

- **Computer:** Become familiar with all the components on the front and back of your computer.
- **Keyboard:** Learn about all the keyboard's capabilities, including one-button access to the Internet!
- **Scroll Mouse:** See how easy it is to use the scroll mouse and learn shortcuts to save time.
- **Speakers:** Enjoy the experience of high-quality sound on your computer.
- **Hard Drive, CD-ROM, and DVD-ROM Drives:** Use the various drives to listen to your favorite CDs or watch movies.
- **Internet Video Camera:** Understand the many capabilities of an Internet video camera.



Note: Illustrations and features shown may differ slightly from those of your Computer.

Your Computer at a Glance

Before you begin, you'll want to become familiar with the components of your Compaq Presario.



Tip

Some components have color-coded connectors that match the ports on the back of your computer.

What's in Front?

- 1 CD-ROM, CD-RW, or DVD-ROM drive
- 2 Disk drive
- 3 CD storage for storing five CDs
- 4 Two USB connectors for connecting USB devices (varies by model)—ports for connecting peripheral devices, such as gamepads, joysticks, and video cameras
- 5 Power button

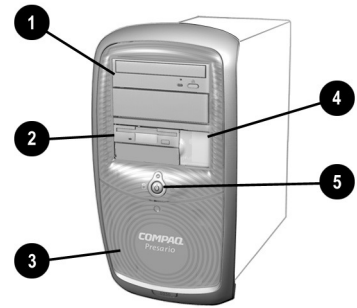

What's in Back?

- 1 Power port
- 2 PS/2 mouse port; PS/2 keyboard port
- 3 USB ports for connecting an Internet keyboard or other USB devices
- 4 Serial port for connecting a serial peripheral device
- 5 Parallel port for connecting a peripheral device, such as a printer
- 6 Audio speaker ports
- 7 Microphone port
- 8 TV out plug
- 9 Modem port for connecting to a phone link
- 10 Ethernet port for connecting to an Ethernet network (if equipped)
- 11 Monitor port

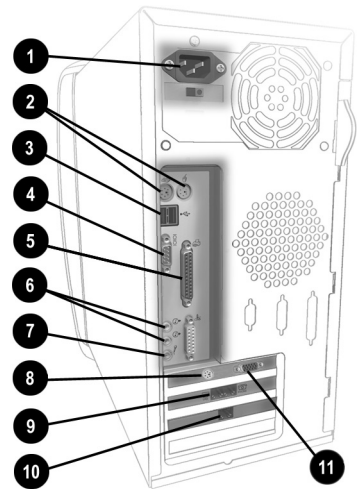

Note: Connectors may vary by model.

Keyboard Basics

The standard keys perform the following functions:

- 1 **Main keys** are the typewriter-style keys.
- 2 **Function keys** are the **F1** through **F12** keys. Two of these keys are active even without a program running. **F1** enables you to get help on Windows-related topics. **F3** enables you to search for files or folders.
- 3 **Arrow keys** can be used for games and to navigate through a document or Web site. These keys allow you to move left, right, up, and down, using the keyboard instead of the mouse.
- 4 **Numeric keys** work like a calculator keypad.

Getting to Know the Standard Keyboard Keys

Some keys have special functions when used alone or combined with other keys. These functions vary depending on the program you are using.

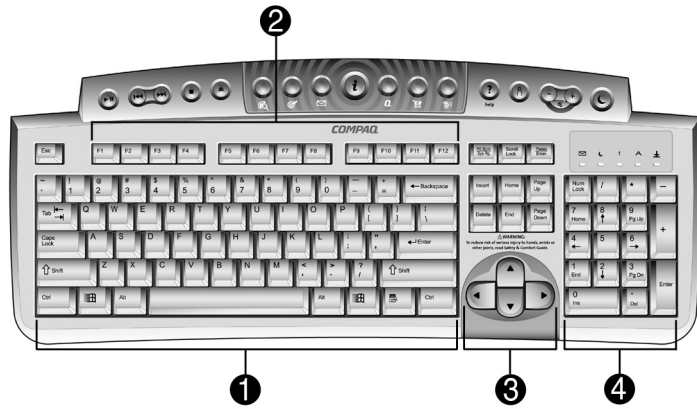

1	Main keys	3	Arrow keys
2	Function keys	4	Numeric keys

Note: Style of keyboard may vary.

Keyboard Buttons

The keyboard buttons make it easier and faster to get on the Internet, use your favorite software, or listen to your favorite CD. You might even want to watch a movie or send an e-mail.

The keyboard buttons are shown in the following illustration. They are discussed in detail on the following pages.

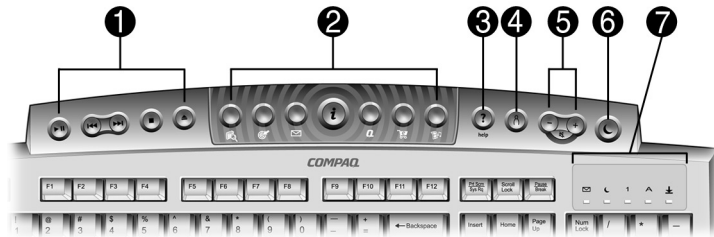

1	CD/DVD Control Buttons	5	Volume/Mute Buttons
2	Internet Zone Buttons	6	Sleep Button
3	Quick Launch Help Button	7	LED Status Lights
4	Quick Launch My Program Button		

The CD/DVD control buttons provide a quick and easy way to play a CD or a DVD movie at the touch of a button. The buttons can also be used to control MP3 files played through Windows Media Player.

Many CDs begin playing automatically when inserted into the drive. Refer to *Playing an Audio CD* in this chapter to play a CD.

Using CD/DVD Control Buttons

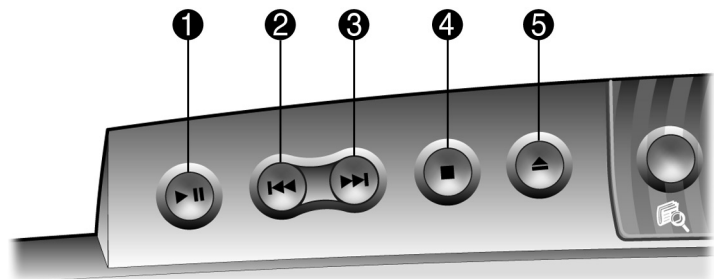

1	Play/Pause starts or stops a CD, DVD, or MP3 temporarily.	4	Stop ends the CD, DVD, or MP3 play, rewind, and fast forward functions.
2	Rewind/Previous Track skips to the previous track.	5	Eject/Load ejects or loads the CD or DVD.
3	Fast Forward/Next Track skips to the next track.		

 **See also ...**

*Refer to **Adjusting the Volume** in this chapter to adjust the volume when playing a CD or a DVD.*

Note: Buttons may vary by model.

Keyboard Buttons, cont.

With the press of a keyboard button, you can get on the Internet fast, read your e-mail, or check out the latest in entertainment.

Depending on which Internet Service Provider (ISP) you have, the default options provided by the Internet Zone buttons may vary.



Did you know ...

Until you set up your Internet Service Provider (ISP), each Internet button takes you to a window that guides you through the ISP set-up process.

Using Internet Zone Buttons

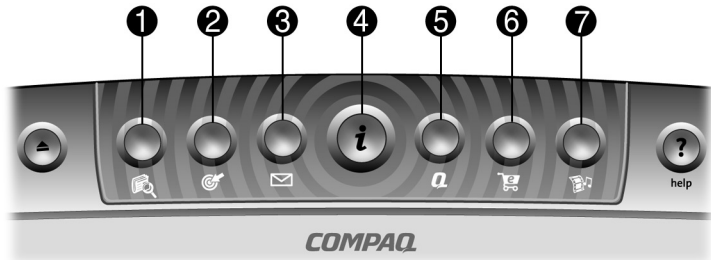

Note: Button functions may vary by model and by region.

No.	Description
①	Search accesses a Web site that helps you to locate news and information on the Internet. Search for topics including news and information, shopping, images, music, and video.
②	Activity launches your favorite Internet Zone activity. The default brings you to your Community center, a vibrant online community experience with chat sessions, discussion boards, clubs, home pages, photo albums, and more. Note: On the Smart Credit Card Internet keyboard, the Activity button is replaced by the Smart Credit Card button. Refer to the "Smart Credit Card Internet Keyboard" section for details.
③	E-mail launches your e-mail application.
④	Instant Internet provides your daily starting point to the Internet. It connects you to a customizable Web page filled with local weather, news, sports, and financial information.
⑤	My Presario is your instant connection to Compaq for getting the most out of your computer and the Internet. Learn about the top Internet Zones, or venture into your favorite Activity Centers, and get creative using the Web.
⑥	Retail/Affinity Central provides an instant connection to your computer store and a variety of leading consumer companies.
⑦	Entertainment is your online scoop for the world of entertainment, featuring music downloads, streaming video, Web casts, entertainment news, and reviews.

Keyboard Buttons, cont.

Some Internet buttons have a default function, and others can be assigned a function such as calling up your favorite Internet page or reading your e-mail. After being assigned a function, these buttons can be reassigned to a different function.

Customizing the Internet Zone Buttons

1. From the Windows desktop, click the **Start** button.
2. Point to **Settings** and then click **Control Panel**. The Control Panel window is displayed.
3. Double-click the **Easy Access Buttons**  icon. A dialog box is displayed asking you to press the Easy Access button you would like to program.
4. Press the Internet button you would like to program. This takes you to a Web site that provides instructions for reassigning the Internet button.

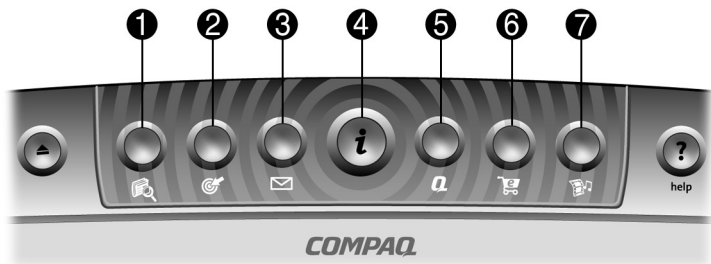

①	Search	⑤	My Presario
②	Activity	⑥	Retail/Affinity Central
③	E-mail	⑦	Entertainment
④	Instant Internet		

Keyboard Buttons, cont.

You can access your favorite program, Web site, or document by pressing the **Quick Launch Web** buttons. These are the **Help ?** and **My Program**  buttons.



See also ...

Refer to “Preventive Maintenance” on the My Presario—Learning More CD for additional information on service and support.

Using Quick Launch Web Buttons

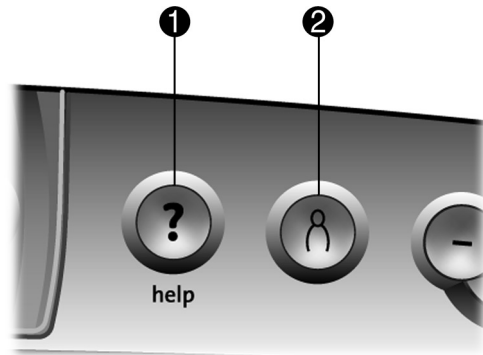

No.	Description
①	Help takes you to service and support information on the Windows desktop.
②	My Program can be programmed to launch your favorite software, Web site, or document.

Note: Buttons and their function may vary by model and region.

Keyboard Buttons, cont.

After you assign the **My Program** ⌂ button settings, pressing the button opens your selected software, Web site, or document automatically.



See also ...

Instructions for reassigning the **My Program** button are found on the My Presario—Learning More CD.

The **Volume Control** buttons allow you to control the volume of your computer. Or, if you want silence, press the **Mute**  button. It's that simple!



Tip

You can also adjust the volume by clicking the **Speaker**  icon located in the system tray at the bottom-right corner of the Windows taskbar.

Assigning the My Program Button

1. Press the **My Program** ⌂ button ❶. The Compaq Easy Access Button Settings dialog box is displayed.
2. Select **Launch a new program** or **Launch a new website**, then click **Next**.
3. If you selected **Launch a new program**, select either **Programs** or **Documents**, then choose the program or document you want to assign to the **My Program** ⌂ button
4. If you selected **Launch a new website**, choose the Web site you want to assign to the **My Program** ⌂ button.
5. Click **OK** to verify your selection.
6. Click **OK**.

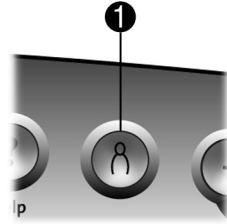

Adjusting the Volume

Use the following buttons on your keyboard to adjust the volume as needed:

- ➔ Press the **minus** — button ❶ to decrease the volume.
- ➔ Press the **plus** + button ❷ to increase the volume.
- ➔ Press the **mute**  button ❸ to turn off the sound.

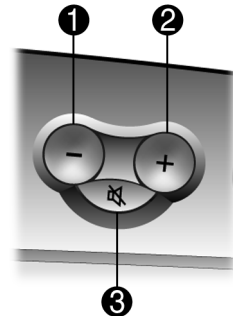

Keyboard Buttons, cont.

If you're going to be away from your computer but want to leave the power on, you can put your computer to sleep. This process allows you to run programs while your computer goes into a low-power state, which saves energy.



Tip

You can wake your computer by moving the mouse, clicking a mouse button, pressing the Sleep button, or pressing any of the keyboard buttons.



Did you know ...

You can change the amount of time that passes before your computer goes to sleep. See the My Presario—Learning More CD for instructions.

Putting Your Computer to Sleep

Press the **Sleep**  button **1** on the keyboard and your computer goes to sleep. Or, your computer goes to sleep automatically if no activity occurs within 20 minutes.

Waking Your Computer

Press the **Sleep**  button **1** on the keyboard and your computer wakes up.



System Status Lights

The system lights on the keyboard provide a quick status of your computer and keyboard settings.



Did you know ...

Post Office Protocol (POP) is a commonly used messaging protocol. The most widely used implementation of this protocol is POP3. POP3 is a retrieval protocol used to retrieve mail messages from a POP server. E-mail messages received by the POP server are delivered to a server mailbox, where they reside until you retrieve them.

Understanding the System Status Lights

The system status lights are shown in the following illustration, and the function of each light is explained.

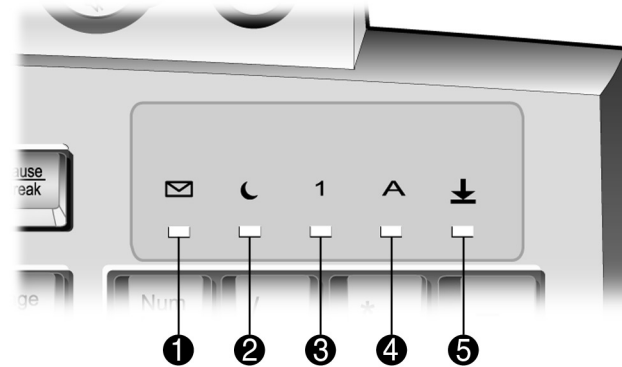

No.	Description
1	E-mail indicates when you have e-mail waiting to be read. Note: This light works only with POP3 Internet services. The light does not work with proprietary Internet services such as AOL.
2	Sleep indicates the computer is in the sleep mode.
3	Num Lock indicates that you can use the numeric key pad to type numbers.
4	Caps lock indicates all text typed will appear as capital letters.
5	Scroll lock indicates when the scroll-lock function is engaged, enabling you to scroll through a document without moving the cursor.

Smart Credit Card Internet Keyboard

(available on select models)

The Smart Credit Card Internet Keyboard makes it easy for you to purchase merchandise online.

Understanding the Smart Credit Card Internet Keyboard

The Smart Credit Card Internet Keyboard has the same features as the standard keyboard with the addition of a **Smart Credit Card** button ❶ and a Smart Card terminal ❷.



Note: The Smart Credit Card Internet Keyboard is classified as a high power USB device. As with any high power USB device, this keyboard needs to be connected directly to one of the USB ports on the front or back of your computer. If an optional external USB hub is used, it must be a powered external USB hub.

Using the Smart Credit Card Feature

1. To apply for a Smart Credit Card or shop at enabled e-merchants, press the **Smart Credit Card** button ❶. This button launches a Web site with instructions on obtaining your Smart Credit Card.
2. When prompted, insert your Smart Credit Card into the Smart Card terminal with the front of the card facing up ❷.
3. Follow the on-screen instructions to complete the transaction.

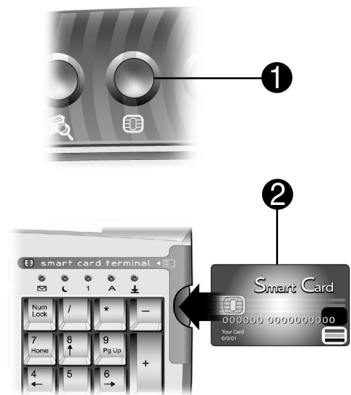

Compaq/ Logitech™ Wireless Wheel Mouse

(available on select models)



Did you know ...

The wireless wheel mouse does not alert you when the batteries are low. You must replace the batteries approximately every six months.



Tip

For optimal performance, place the receiver at least eight inches (twenty centimeters) away from other electrical devices, such as the computer, the computer monitor, or external storage devices.



See also ...

If your wireless wheel mouse does not function properly after installation, refer to the “Troubleshooting” section in Chapter 6 of this guide.



See also ...

For information about using your wireless wheel mouse, refer to the “Scroll Mouse and Wireless Mouse” section on the next page.

Installing the Wireless Wheel Mouse

Note: Before using your wireless wheel mouse, refer to the Comfort Guidelines on Logitech’s Web site at:

www.logitech.com/cf/support/comfortguide.cfm

1. Remove the battery compartment cover by pressing the tab on the bottom of the mouse ① and sliding off the cover ②.

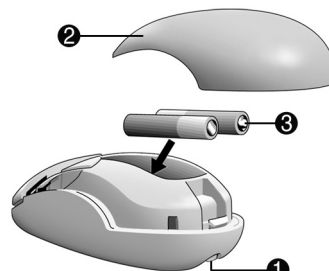

2. Insert the two AAA alkaline batteries ③ according to the diagram inside the battery compartment.

3. Turn off your computer.

4. Connect the receiver cable to the PS/2 port ④ on the back of your computer.

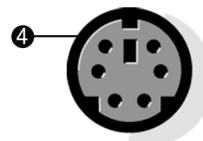

5. Turn on your computer.

6. Establish communication between the mouse and the receiver by pressing the **Connect** button ⑤ on the receiver, then pressing the **Connect** button ⑥ under the mouse.

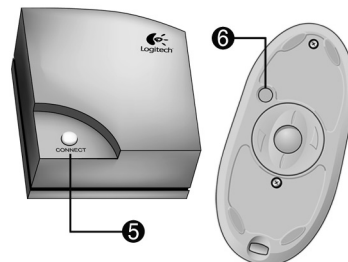

Scroll Mouse and Wireless Mouse

Your computer comes with a scroll mouse. The scroll mouse directs a cursor on the Windows desktop. Use the mouse to move quickly and easily through a document or Web site.

Moving the scroll wheel on your mouse forward or backward through a document or Web site is faster than using the scroll bar.

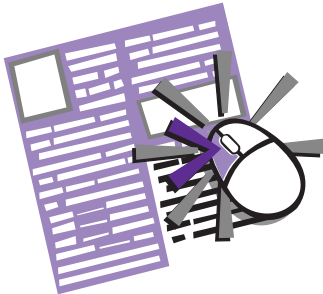

Tip

Some mouse functions may not work with all software.

Making Screen Selections

Click by pressing and releasing the left mouse button quickly one time. You will hear a single clicking sound.



Opening Software and Files

Double-click by quickly pressing and releasing the left mouse button twice.



Scrolling

Click (and hold down) on the scroll handle (the box in a scroll bar area) and drag it up or down until the desired text is displayed in the window. Or single-click the arrow buttons to move up or down one line at a time.

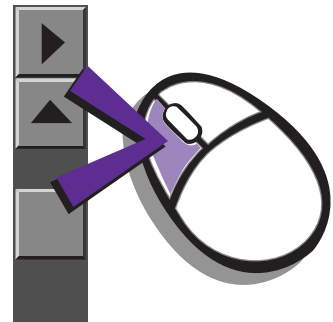

Positioning the cursor on the scroll bar and clicking above or below the scroll handle moves the text up or down a screen at a time.

Scroll Mouse and Wireless Mouse, cont.

AutoScroll allows you to move forward and backward through a document without having to move the mouse or mouse wheel continuously.



Did you know ...

*The scroll mouse can be customized for a left-handed user from the Mouse Properties dialog box. Click on **Start / Settings / Control Panel** and double-click on the mouse icon to open the Mouse Properties dialog box.*

Autoscrolling

1. Open a program and press the scroll wheel to begin autoscrolling.
2. Move the mouse once in the direction you want to scroll (vertically, horizontally, or diagonally). The farther you move the cursor from the starting point, the faster the scrolling occurs.
3. To stop autoscrolling, press a mouse button.



Speakers

(available on select models)

Speaker options depend on which model you purchase. However, the JBL Platinum Series are the standard speakers that come with most new Compaq Presario monitors. You can use the speakers freestanding or mount them on the side of the monitor. For more information, see the documentation that came with the speakers.

To set up the speakers, follow the directions on the monitor's Quick Set-Up poster. If you purchased speakers separately, follow the instructions included.



Did you know ...

You can plug a digital MP3 portable audio player into the Audio-In port on the right side of the speaker (on JBL Platinum Series speakers). Other portable music players include:

- *CD players*
- *Cassette players*
- *AM/FM Stereo*

These devices connect with a stereo cable (3.5 mm/3.5 mm plug) available from most electronics stores and computer retailers.

Turning on the Speakers

To turn the speakers on or off, press the **Power** button on the right side of the speaker. You can adjust the volume after the button pops out.

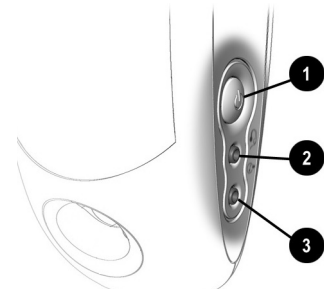

No.	Description
①	Power Button —conveniently allows a quick power down when not in use, or mutes the sound. Simply push the button so that it pops out. The light indicates when the power is on.
②	Headphone Jack —allows you to connect most stereo headphones for your personal listening pleasure.
③	Audio-In Port —an advanced feature that lets you quickly connect your favorite digital MP3 player (or any portable audio device) to play audio directly through the speakers.

Note: The speakers receive power from the monitor, even when the monitor power is off. Your portable music player can be played through the speakers without turning on your computer.

Disk, Hard Drive, CD-ROM, CD-RW, DVD-ROM, and DVD-R Drives

Your computer may have one or more drives depending on the model you purchased:

- Disk drive
- Hard drive
- CD-ROM drive
- CD-RW drive
- DVD-ROM drive
- DVD-R drive

Each drive has a different capacity for storing information.

The disk drive uses a floppy disk to store files. Once information is copied onto a floppy disk, it remains there until you delete or overwrite it.

The other drives are discussed on the following pages.

Using the Disk Drive

1. Hold a floppy disk with the label facing up and the arrow on the disk pointing toward the drive; then gently push the disk into the drive.
2. To remove a floppy disk, press the **Eject** button ❶ on the disk drive.

▲ **Caution:** Wait until the disk drive activity is complete (the activity light ❷ stops glowing) before removing a floppy disk. Removing a disk when the drive is reading from or writing to the disk can damage the disk or the information stored on it.

Note: Remove the floppy disk from the drive prior to shutting down Microsoft Windows.

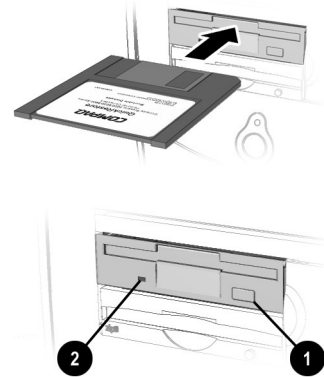

Using the Hard Drive

The hard drive stores system files, software, and data files inside your computer. When you install software, download files from the Internet, receive e-mail and attachments, or create new files, the computer saves them on your hard drive. The available storage space is gradually filled. To regain storage space, you can delete files or programs loaded on your computer, or save them on external media such as floppy disks, CD-R discs, or CD-RW discs.

Disk, Hard Drive, CD-ROM, CD-RW, DVD-ROM, and DVD-R Drives, cont.

The CD-ROM drive enables you to read data from a CD or listen to a music CD.

The CD-RW drive enables you to read and write data to a disc for storage, and enables you to listen to music CDs or read data CDs.

The DVD-ROM drive enables you to view your favorite movies, listen to music, or read information from CDs.

The DVD-R drive enables you to view your favorite movies, record your own movies, listen to music, or read information from CDs.





Tip

If a CD doesn't play, make sure the drive is closed.

Inserting a CD into the CD-ROM, CD-RW, DVD-ROM, or DVD-R Drive

(number and style of drives vary by model)

Note: Your computer must be turned on before you can insert or remove a disc.

1. Press the **Load/Eject**  **1** button to open the drive.
2. Carefully lift the disc from the CD case. Hold the disc by the edges and the center hole only, to avoid touching the surface.
3. Place the disc, label side facing up, into the round area of the tray. If the tray contains support tabs, carefully slide the disc under the tabs to position it correctly in the tray.
4. Press the **Load/Eject**  **1** button to close the drive.

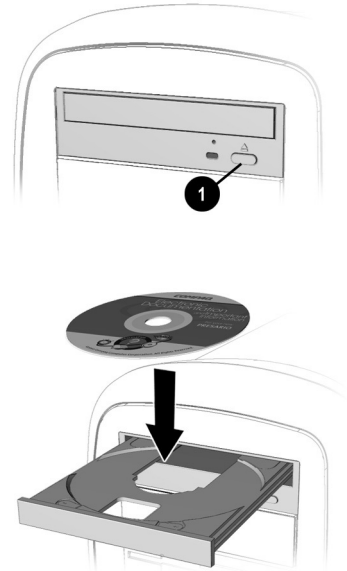

Disk, Hard Drive, CD-ROM, CD-RW, DVD-ROM, and DVD-R Drives, cont.

A CD-ROM drive reads CDs, CD-R, and CD-RW media. DVD-ROM and DVD-R drives read all CD media plus DVD discs.

When you have finished listening to the CD, store the disc in the storage compartment on the front of your computer or in its protective case.



See also ...



To adjust the volume, refer to “Adjusting the Volume” in this chapter.



Did you know ...



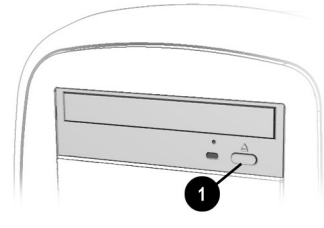

If the CD-ROM, CD-RW, DVD-ROM, or DVD-R drive can't play a disc, check to be sure that the disc is inserted with the label face-up and properly seated in the drive. The DVD-ROM and DVD-R drives take longer to begin playback because they must determine the type of media being played.

Removing a Disc from a Drive

1. Press the **Load/Eject**  **1** button to open the drive.
2. Carefully lift the CD or the DVD from the drive.
3. Press the **Load/Eject**  button on the front of the drive to close the door.
4. Store the disc in its protective case or in the storage compartment on the front of the computer.



Playing an Audio CD

1. Insert a disc into the drive with the label face up.
2. If after a few seconds the disc does not automatically start playing, press the **Play/Pause**  button on the keyboard.
3. Perform the following tasks using your Internet keyboard as needed:
 - Click the **Play/Pause**  button to pause play.
 - Click the **Forward**  and **Back**  buttons to skip tracks.
 - Click the **Stop**  button to stop playing the CD.
 - Press the **Eject** button on the drive to remove the disc.



Disk, Hard Drive, CD-ROM, CD-RW, DVD-ROM, and DVD-R Drives, cont.

You can only play a DVD movie from a DVD-ROM or DVD-R drive. When you finish watching a movie, store the DVD disc in its protective case.



Tip

You can control the actions of the DVD player (pause, rewind, and so on) from the CD/DVD control buttons on the keyboard.



See also ...

Refer to “Adjusting the Volume” in this chapter to adjust the volume when playing a DVD disc.

Playing a DVD-ROM Movie

1. For best performance, close all running programs before inserting a DVD movie. Insert the DVD disc into the DVD-ROM or DVD-R drive. Playback begins automatically.
2. If playback does not begin automatically, click the **Start** button on the Windows taskbar.
3. Point to **Programs**, and then **Compaq DVD Express ❶**. (For the WinDVD player ❷ [lower picture], point to **Compaq WinDVD**.)
4. Choose **Compaq DVD Player ❶** (select **DVD Player** if you have WinDVD ❷) and then click the **Play ▶** button.



Disk, Hard Drive, CD-ROM, CD-RW, DVD-ROM, and DVD-R Drives, cont.

The CD-RW drive allows you to create your own CDs. You can buy two types of media: CD-R and CD-RW discs.

CD-R media can be played on most of the newer CD players, CD-ROM, DVD-ROM, and DVD-R drives. CD-R media can be written to only once.

However, you can write to CD-RW media using multiple recording sessions until you close out the disc.

CD-RW media can be used to make backups of your personal CDs or hard disk. These discs are re-usable and can be erased and rewritten to numerous times.



See also ...

For more information about using the CD-ROM, CD-RW, or DVD-ROM drives, refer to the My Presario—Learning More CD.

Creating Your Own CDs

CDs are created using the Adaptec Easy CD Creator (available on select models). Various uses of the CD-RW drive are shown below.

Note: Confirm that the Easy CD Creator software is installed before you begin trying to create CDs.

Media	Uses
Audio	Create personal music CDs with your favorite music tracks and MP3/WMA files.
Data	Create a data CD to store data, such as files or folders from the hard disk. This feature is useful for backing up important files or for sharing data with other people.
Direct CD	Write files directly to a CD-R/CD-RW just like you copy files to a disk drive. Drag-and-drop files from one drive to another in Microsoft Explorer without accessing Easy CD Creator.
CD Copier	Create an entire copy of a CD or a backup of data files.
Jewel Case Creator	Make custom jewel case inserts and CD labels to indicate the title and contents of a CD (labels are sold separately).

The Adaptec Easy CD Creator software is intuitive. When you place the cursor over any of the functions, a description of the function is displayed.

Note: There is an extensive online Help built into the software. To view online Help you must load Adobe Acrobat Reader from the *My Presario—Learning More CD*.

Internet Video Camera

The Logitech QuickCam Express Internet video camera provides many useful features:

- Captures images at the touch of a button
- Sends photo and video e-mail as easily as text
- Allows video chatting for a face-to-face get-together with faraway friends and family
- Enables you to save, print, or send an image over the Internet with easy-to-use software
- Quickly creates a personal video
- Has one-click *Web camming*, which lets you put the special events in your life online

Using the Logitech QuickCam Internet Video Camera (available on select models)

The Logitech camera installs within minutes. Refer to the Logitech documentation packed with the camera for detailed operating instructions.

Note: Do NOT plug the camera into your Internet PC until instructed to do so during the QuickCam software installation.

The camera software comes with free access to the Logitech Spotlife Web site which includes 15 MB of free Web space for:

- Video broadcasting live over the Internet
- Chatting directly with viewers using text or audio

Visit the Spotlife Web site at www.compaq.com/go/spotlife



Welcome to the Web

3

In This Chapter

Basic Concepts, 3-2

Compaq Connection Helper, 3-3

Internet Connection, 3-4

E-mail, 3-5

Content Advisor, 3-9

In just a few moments, you will be on the World Wide Web. It is estimated that thousands of new users will join you in connecting to the Internet for the very first time!

In this chapter, you begin to explore the endless possibilities of the Internet—e-mail, shopping, news, entertainment, research, education, and much more. Procedures are provided for American Online (AOL) users.

Welcome to the World Wide Web. You are about to enter a very exciting new world!



Basic Concepts

Internet, Web, URL, hyperlinks, cyberspace—sound confusing?

The Internet definitely has its own terminology. Take a few moments to understand some basic concepts that will help you start surfing the Web.

To begin surfing, you need to establish an Internet Service Provider (ISP) account.

What Is the Internet?

The Internet is a network of computers connected using standard telephone lines. The Internet is worldwide, like the telephone system.

The Internet stores and transmits documents, pictures, music, and movies provided by computer users from all over the world.

When information on a particular topic, or on related topics, is gathered in one location on the Internet, that's called a Web site.



What Is a Hyperlink?

Imagine you're reading a newspaper. As you read page 1, it says something like “For more details, see page 3, column 2.”

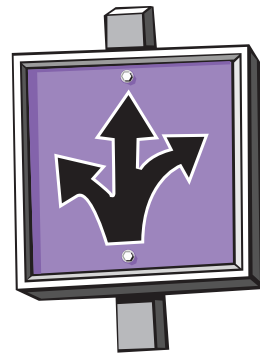

Hyperlinks in a Web site work the same way. Use the mouse to click a hyperlink and you can move instantly from page to page, Web site to Web site. Linking files together is what gives the Web its name, weaving and connecting idea to idea, all over the world.



Compaq Connection Helper

Once you sign up with an Internet Service Provider (ISP), there are a few things you need to know to be able to surf the Web.

If you choose AOL as your ISP, you need to use the Compaq Connection Helper to reset the following Internet buttons on your keyboard:

- **Instant Internet** *i*
- **Search** 
- **Instant E-mail** 

Setting the Internet Buttons to AOL

1. On the Windows taskbar, click the **Start** button.
2. Point to **Programs**, and then **Compaq Utilities**.
3. Choose **Compaq Connection Helper**. The Compaq Connection Helper dialog box is displayed.
4. Double-click the **AOL** icon. The Internet keyboard buttons will now access **AOL**.



Internet Connection

Web pages are viewed with a Web browser, such as Microsoft Internet Explorer or Netscape Navigator. A Web browser lets you view and explore information on the Web.

Common features of a Web browser include:

- ➔ Home page—your starting point for exploring the Web
- ➔ Search engine—takes information scattered on Web sites around the world and lists it for easy viewing and printing
- ➔ Bookmarks/Favorites—a list of Internet addresses you often visit
- ➔ History list—a list of Web sites you have visited

See also ...

The My Presario—Learning More CD has more information on Web browsers, e-mail, and news reader settings.

Note: Depending on the version of AOL you are using, your screen may vary from the images shown.

Connecting with AOL

If you have chosen AOL as your ISP and completed “Setting the Internet Buttons to AOL,” press the **Instant Internet**  button to access the AOL home page. The appearance of your screen varies with the version of AOL.



Searching the Web Using AOL

1. Complete the “Setting the Internet Buttons to AOL” procedure.
2. Press the **Search**  button on the Internet keyboard. The AOL search page is displayed.



3. Enter a keyword in the Search box **1**.
4. Click the **Search!** button **2**. The search engine displays a list of Web pages containing your keyword.

E-mail

E-mail (electronic mail) is very similar to the mail the postal carrier delivers to your home or office, except much faster.

You can send letters, pictures, postcards, even music and video clips, to friends, family, and co-workers in an instant.

Outlook Express is an e-mail program that comes with your computer. Other e-mail programs include AOL and Hotmail.



Tip

If you receive an error message saying that your e-mail was undeliverable, check the address, punctuation, and spacing, and then try sending it again.

Setting Up Outlook Express E-mail

1. Press the **Instant E-mail**  button on the Internet keyboard.

Note: If the Internet Connection Wizard starts, Outlook Express is not preconfigured and you must go through the configuration process. Contact your ISP for the proper configuration settings.

2. Click the **Send and Receive** button on the toolbar. A dialog box requesting your password is displayed.
3. If you are prompted for a password, type in your password.
4. Click **Remember Password**.
5. Click **OK**. You are now set up and ready to use e-mail.

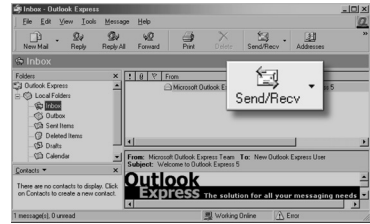

Typing an E-mail Message

Regardless of the e-mail software you choose, creating an e-mail message is like filling out a form. When typing an e-mail message, you must complete the following:

Feature	Description
To:	E-mail address of the recipient
Cc:	Person(s) receiving a copy of your message
Subject:	Summary of your message in a few words
Message:	Content of your message

E-mail, cont.

To send and receive e-mail, you need an e-mail address so that your Internet Service Provider (ISP) will know where to pick up and deliver mail.



See also ...

The My Presario—Learning More CD has information on finding e-mail addresses.



Did you know ...

E-mail extensions identify the type of server where an organization resides. Some of the most common e-mail extensions and their descriptions are as follows:

Extension	Description
.org	organization
.com	commercial
.net	network
.edu	education
.gov	government agencies
.mil	military

Understanding E-mail Addresses

Some ISPs allow you to pick an e-mail address, but others require you to follow a set pattern:

- your name
- @
- ISP server name

ISP names can be longer and more complex, but basically anything to the right of the @ sign is the ISP server name and anything to the left is the user name. For example:



E-mail, cont.

Now that you've connected to an ISP, set up Outlook Express, and have an Internet address, it's time to write your first e-mail message.



Tip

E-mail addresses are written in a very specific way. Be sure the e-mail address you enter contains no spaces and has a period after the server name. Dashes and underscores may be used. Capital letters may be required. Ask e-mail recipients exactly how to write their e-mail address.



See also ...

The My Presario—Learning More CD has more information on using e-mail.

Sending an E-mail Using Outlook Express

1. Press the **Instant E-mail**  button on the Internet keyboard.
2. Click the **New Mail Message** icon **1**.
3. Type the recipient's e-mail address in the **To** box **2**.
4. Type the subject of your message in the **Subject** box **3**.
5. Type your message in the message window **4**.
6. Click **Send** **5**.



E-mail, cont.

Now that you've connected to an ISP, set up Outlook Express, and have an Internet address, it's time to write your first e-mail message.



Tip

E-mail addresses are written in a very specific way. Be sure the e-mail address you enter contains no spaces and has a period after the server name. Dashes and underscores may be used. Capital letters are not required. Ask e-mail recipients exactly how to write their e-mail address.



See also ...

The My Presario—Learning More CD has more information on using e-mail.

Sending an E-mail Using AOL

1. Press the **Instant E-mail**  button on the Internet keyboard.
2. Click the **Write** icon on the AOL toolbar.
3. Type the recipient's e-mail address in the Send To box **1**.
4. Type the subject of your message in the Subject box **2**.
5. Type your message in the message window **3**.
6. Click **Send Now** **4**.

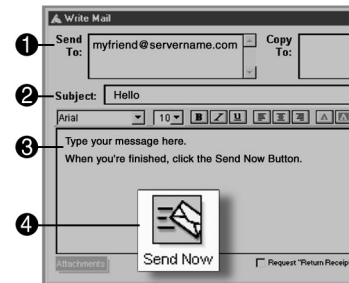



Content Advisor

You receive e-mail messages automatically, even when your computer is shut down! Your ISP stores these messages until you decide to open your e-mail program and read them.

Your e-mail status light on the keyboard glows when you have e-mail.



The e-mail status light only works with POP3 Internet services. The light does not work with proprietary Internet services such as AOL.

Reading Your Outlook Express E-mail Messages

1. Press the **Instant E-mail**  button on the Internet keyboard.
2. Click **Inbox**. New messages appear in bold type.
3. Double-click the message to display the message text.
4. Click the **Close**  button in the upper right corner of the screen to close the e-mail, or press the **Delete** key on the keyboard to delete the message.



Reading Your AOL E-mail Messages

1. Press the **Instant E-mail**  button on the Internet keyboard.
2. Click the **Read** icon. New messages appear in bold type.
3. Double-click the message to display the message text.
4. Click the **Close**  button in the upper right corner of the screen to close the e-mail, or press the **Delete** key on the keyboard to delete the message.

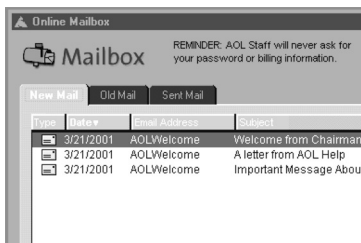

Content Advisor, cont.

The Internet provides you with access to a wide variety of information, but some information may not be suitable for every viewer.

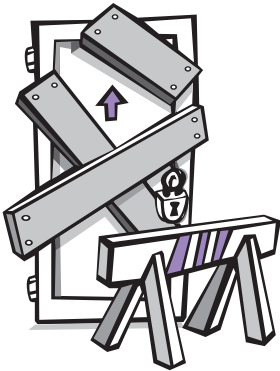

With Content Advisor, you can:

- Control Internet access
- Set up a password
- Set up a list of Web sites that people who use your computer cannot view
- Adjust the types of content people who use your computer can view with or without your permission

Restricting Internet Content

1. On the Windows taskbar, click **Start**, point to **Settings**, then **Control Panel**, and then **Internet Options**.
2. Click the **Content** tab **1**.
3. In the Content Advisor area, click **Enable** **2**.
4. Click **Settings**, and then type your password in the Password box.
5. Click a category in the list, and then drag the slider to set the limits you want to use.
6. Repeat this process for each category you want to limit, and then click **OK**.



Common Tasks

4

In This Chapter

Print Basics, 4-2

Games and Digital Audio
Files, 4-3

Software, 4-4

In this chapter, you learn how to perform some of the more common activities with your new Internet PC.

More details about these and other everyday activities can be found on the *My Presario—Learning More* CD.



Print Basics

To print one or more pages from a document file or Web page, you have to connect your printer and install the necessary software.

To see what the document will look like when printed, select the **Print Preview** option from the **File** menu. This option is available in most software packages.



See also ...

For additional information about your printer, refer to the manufacturer's documentation.

Using the Menu to Print

1. Click **File** on the menu bar.
2. Click **Print**. The *Print* dialog box is displayed.
3. Select the printing options you want.
 - Confirm which printer you are printing to ❶.
 - Choose the page range to print ❷:
 - All pages
 - The current page you are viewing
 - A range of pages (for example, 1–4)
 - Confirm the number of copies you want to print ❸.
 - Select All, Odd, or Even pages in range ❹.

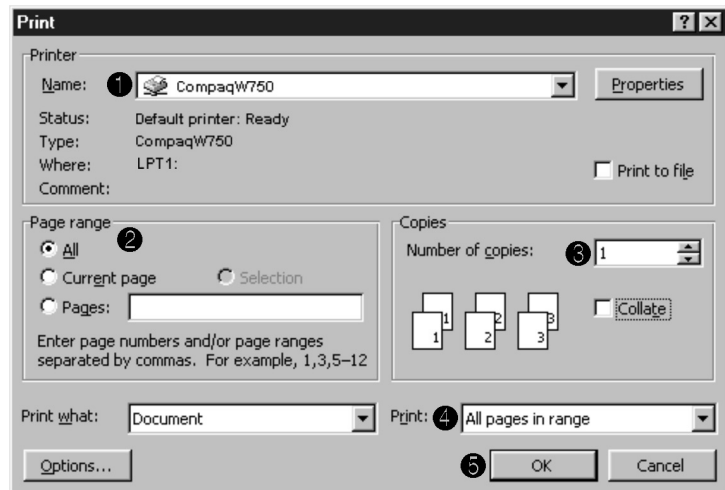

Note: These options vary depending on the printer installed.

4. Click **OK** ❺.

Games and Digital Audio Files

Your new Internet PC is not only a powerful tool for surfing the Internet and running software, it also allows you to play games.



Did you know ...

You should always use the same disc drive (CD-ROM or DVD-ROM) that you used to install a game when you play the game. If you experience problems installing or playing a game, contact the game manufacturer for assistance, or visit their Web site for updates.

Your computer can also play digital audio files, such as music downloaded from the Internet. You can download MP3 files and play them using Audio Manager software (available on select models).

Playing Games

Your computer came with several Windows games preinstalled, and many more are available for purchase or by downloading them from the Internet. You can play games online with other players from all over the world.

Note: Before purchasing a game, check the computer requirements (listed on the outside of the game box) to make sure that your computer is configured correctly for the game you want to buy.

Playing Digital Audio Files

1. From the Windows taskbar, click the **Start** button.
2. Point to **Programs** and then select the **Audio Manager** program. The Audio Manager screen is displayed.
3. Follow the on-screen instructions for creating and playing a play list. For help with specific functions, press the **F1** key or choose **Help Topics** from the Help menu.

Software

You may want to purchase and install additional software. Software can be installed from a CD, DVD, or disk, and it can be downloaded from a Web site.

The installation process begins automatically when you insert the CD in the disc drive. If the installation process does not begin automatically, refer to the documentation that came with the software. If no documentation exists, follow the procedure listed here to install software from a CD or disk.

In the event of difficulties with the installation, contact the software manufacturer.



Tip

When selecting software for your computer, make sure the packaging states that it is compatible with your version of Microsoft Windows, your computer memory, processor, and available disk space.

Installing Software from a CD, DVD, or Disk

1. Close all open programs, and follow the installation instructions for that software.
2. From the Windows taskbar, click the **Start** button, point to **Settings**, and then click **Control Panel**.
3. Double-click the **Add/Remove Programs**  icon. The Add/Remove Programs Properties window is displayed.
4. Click **Install**.
5. Insert the CD or disk into the proper drive and click **Next**. Microsoft Windows begins the installation process.

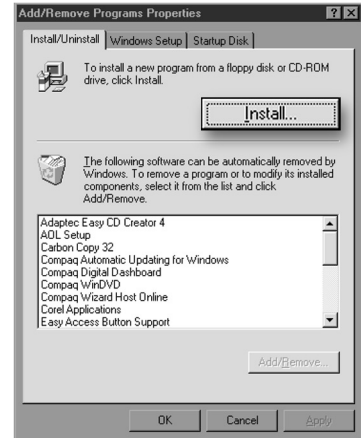

Software, cont.

If you download software from a Web site, follow the installation instructions that are usually displayed on the Web page. If installation instructions are not available, complete the steps listed here.



Tip

Before downloading files of any kind from the Internet, make sure that call-waiting is disabled and that your anti-virus utility is running.



Did you know ...

If the download process is interrupted, you must restart the entire download procedure from the beginning.



See also ...

For more information on anti-virus software, see “Preventive Maintenance” on the My Presario—Learning More CD.

Installing Software Downloaded from the Internet

1. Before you start downloading, note the location on the hard drive where the files will be stored. Also, be sure that you have enough hard drive space available.
2. After the download is complete, terminate your Internet connection.
3. Close all other open programs.
4. On the Windows taskbar, click **Start**, point to **Settings**, and then click **Control Panel**.
5. Double-click the **Add/Remove Programs** icon. This window is displayed.
6. Click **Install**. A window is displayed.
7. Click **Next**. The Run Installation Program window is displayed.
8. Click **Browse**.
9. Locate and select the **Setup.exe** or **Install.exe** file for the downloaded software.
10. Click **Open** to begin the installation process.

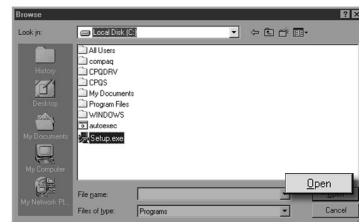
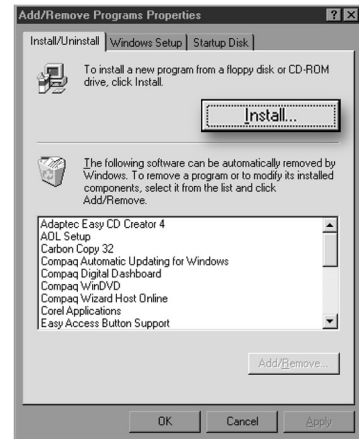

Computer Upgrades

5

In This Chapter

Internal Components, 5-2

Upgrading Components,
5-3

Adding Components, 5-6

In this chapter, you learn how to access the internal parts of the computer and how to perform basic upgrades.

Many components of the computer are replaceable and upgradable. This chapter should be used as a supplement to the instructions provided with your new component.



Internal Components

Your Computer is constructed with an Easy Access panel. This design makes accessing the internal parts easy.

Warning

Failure to disconnect the power from the computer may result in personal injury.

▲ Caution: Before working with the components inside the computer, you must ground yourself and the equipment to prevent damage to the parts from static electricity. To discharge any static buildup, touch a metal part of the computer chassis before touching any internal parts.

Did you know ...

The screw(s) securing the side access panel are for shipping purposes only and do not need to be replaced.

Accessing Internal Computer Components

1. Press the **Power** button to turn off the computer.
2. Disconnect the power cable from the wall and the computer.

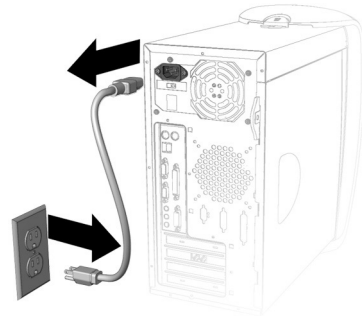

3. Remove the screw(s) securing the side access panel.
4. Locate the latch directly below the screw, pull the latch down, and hold it in the down position.

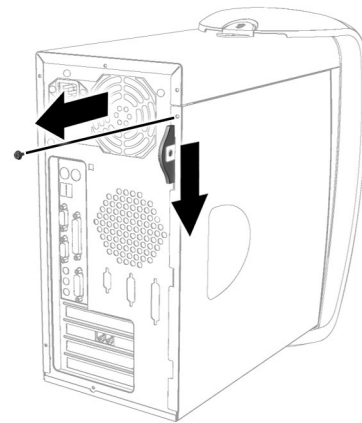

5. Grasp the indented hand-hold and slide the side panel from the chassis.
6. Turn the computer on its side with the open side facing up.

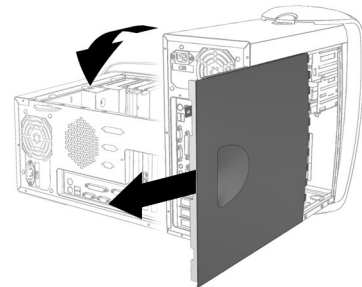

Upgrading Components

The CD-ROM, CD-RW, and DVD-ROM drives are often called optical drives because they use light to read and write information.

Your CD-ROM drive reads data from a CD. They are a popular choice for software and data distribution due to the combination of a large storage capacity and high-quality performance.

The CD-RW drive uses advanced technology to write and rewrite to compact disc(s). CD-RW drives are capable of writing multiple formats to save data, video, and audio files.

The DVD-ROM drive allows you to listen to music or watch movies.



Did you know ...

You do not have to place the lock in the up position after replacing the new drive(s).

Upgrading the CD-ROM, CD-RW, and DVD-ROM Drives

1. Complete the “Accessing Internal Computer Components” procedure.
2. Locate the drive door lock inside the chassis.
3. Rotate the lock to the down position to unlock the upper front panel door.
4. Press the indentation located on the lower front panel to open the lower door.

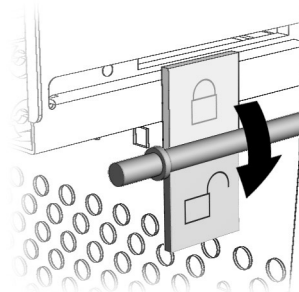

Upgrading Components, cont.



Tip

The upper front panel door is designed with finger holes to make opening the door easy.



Tip

The drive data cable has a color pull-tab to help you identify the cable.



Tip

The drive rails snap on and off the drive(s). Save the drive rails that came with your computer. They will be used on your new drive(s).

5. Grasp under the bottom of the upper front panel door, lift up, and gently remove it from the hooks.
6. Press in both sides of the drive rails and pull the empty drive bay from the front of the computer.
7. Remove the rails from the empty drive bay. Attach them to the new drive by connecting them to the industry-standard holes located on each side.
8. Slide the drive into the empty drive bay.
9. Connect the data cable to the new drive.

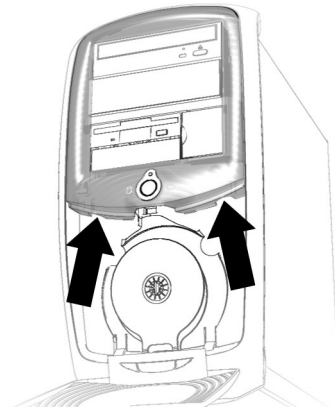

10. Connect the audio and power cables to the new drive.

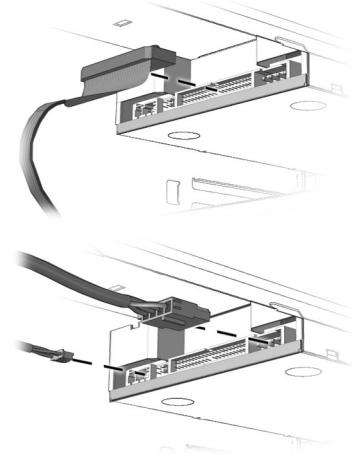

Upgrading Components, cont.

Random access memory (RAM) is the working space of your computer. Data and instructions are stored temporarily in memory. The most powerful processor and the fastest hard drive will not perform well without the workroom to keep the program and data close at hand.

There are several different types of memory modules. Your computer uses Synchronous Dynamic Access Memory (SDRAM).



Did you know ...

If a blank screen is displayed after replacing the memory module, the memory is installed incorrectly. Repeat the procedure to ensure that the memory module is properly positioned.



Tip

Upgrade the memory in your computer with modules of the type and speed that are identical to the memory originally installed in your computer.

Upgrading Computer Memory

1. Complete the “Accessing Internal Computer Components” procedure.
2. Pull outward on the release latches found on both ends of the memory slot **2**.
3. Align the memory module **1** with the memory slot on the system board.
4. Push the module carefully and firmly into the slot, ensuring that the latches **2** on both ends snap into place.

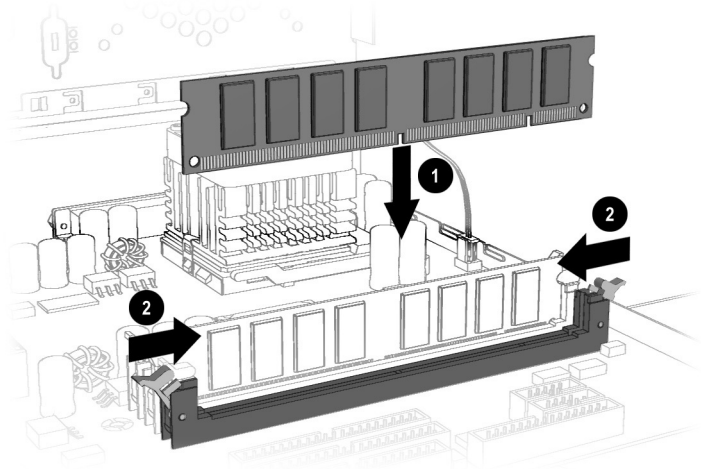

Note: Press gently to ensure the memory module is properly positioned.

Adding Components

The hard drive is used to store information permanently inside your computer.



Did you know ...

You need a screw and a data (ribbon) cable to install an optional hard drive. The empty bracket for the optional hard drive already exists in your computer chassis.



Tip

The existing hard drive data cable has a color pull-tab to help you identify the cable. You must replace the existing data cable for the optional hard drive to function properly.

Adding the Optional Hard Drive

1. Complete the “Accessing Internal Computer Components” procedure before adding an optional hard drive. The optional hard drive shown may differ slightly from your particular optional hard drive.

▲ Caution: Dropping the hard drive may cause the read/write heads to dig into the media, resulting in damage to the heads and the media, and loss of data.



2. Remove the screw that secures the empty hard drive bracket to the chassis included within the system. Insert the second hard drive, and line up the two pins on the bracket with the holes on the hard drive. Snap the optional hard drive in place inside the optional hard drive bracket.

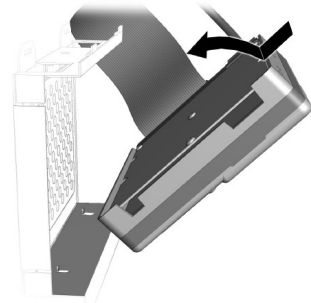

3. Insert the screw from your purchased kit to secure the hard drive to the bracket.

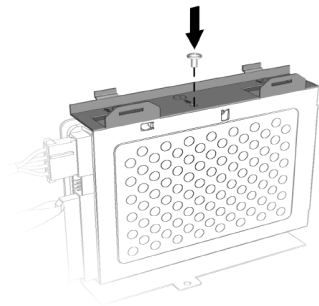

Adding Components, cont.

4. Line up the hard drive data cable with the pins on the hard drive. Make sure you do not bend the pins. Connect the hard drive data cable ❶ and power cable ❷ to the new hard drive.

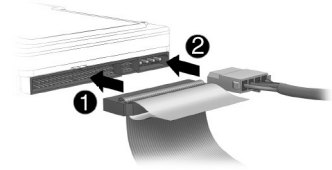

5. Insert the optional hard drive bracket tabs ❶ into the primary hard drive bracket slots ❷. Ensuring that all cables are clear, push the base of the optional hard drive bracket into position.

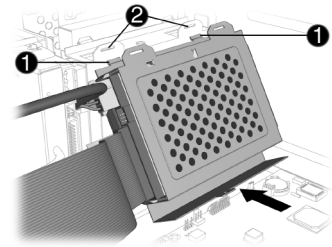

6. Replace the screw securing the optional hard drive bracket to the chassis.

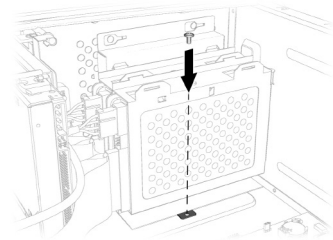

Note: If you had your computer custom-built, you must load the files from the Emergency Diskette onto the optional hard drive.

Adding Components, cont.

An expansion card is a circuit board that fits into a computer expansion slot. The card adds a certain function such as a modem, sound or audio card, Network Interface Card (NIC), or Small Computer System Interface (SCSI) adapter.

This topic shows you how to add or replace expansion and option cards in your computer.



Did you know ...

The type and number of expansion slots may vary by computer model.



Tip

Be sure the expansion card is properly positioned in the rear connector slot on the chassis.

Adding an Expansion or Option Card

Note: Some Presarios come with AGP slots for graphics card options only.

1. Complete the “Accessing Internal Computer Components” procedure.
2. Align the card **1** with the connector on the system board and with the rear connector slots **2** on the chassis.
3. Insert the card carefully and firmly into the connector on the system board.

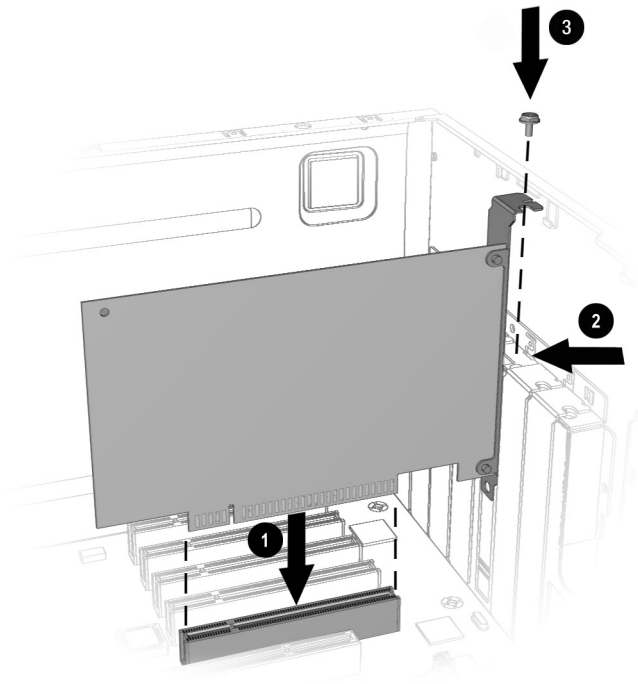

4. Place the slot screw **3** into the chassis slot and secure the expansion card to the chassis.

Need Some Help?



In This Chapter

Helpful Hints, 6-2

Recovery CD, 6-3

Compaq Support, 6-4

Troubleshooting, 6-5

This chapter provides information for identifying and solving common problems that may occur with your computer. You can easily diagnose and solve many computer problems on your own without contacting a technician. In addition, you can find helpful information on our Web site:

www.compaq.com/consumersupport

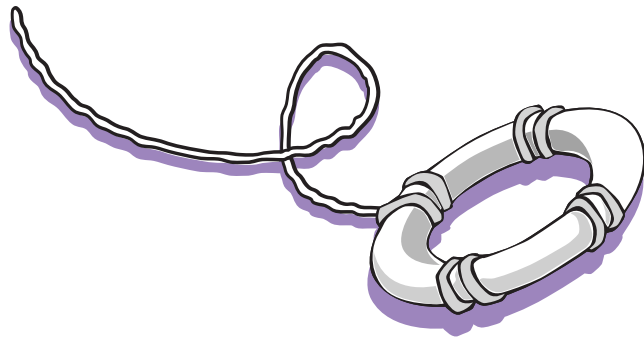

Helpful Hints



Did you know ...



To avoid long-distance charges when connecting to the Internet, always use a local area telephone number.



See also ...

For additional troubleshooting information relating to your printer or monitor, see the documentation that came with your equipment.

If you encounter problems with your computer, monitor, or software, review the following checklist before taking further action:

- Check that the computer and monitor are plugged into a working electrical outlet.
- Check to see that the computer is turned on and the Power light  located on the front of the computer is on.
- Check to see that the monitor is turned on and the Power light  on the front of the monitor is on.
- Turn up the brightness and contrast controls of the monitor if the screen is dim.
- Check all cable connections for loose or incorrect connections.
- Remove any disk from the disk drive before turning on your computer.
- Run Windows Diagnostics to determine and repair minor problems. Refer to the *My Presario—Learning More* CD for instructions.

Recovery CD

The Recovery CD can reinstall the software to its original state when you purchased the computer.

You also have the option of restoring your computer to the way it was when you performed the last User Backup.



Tip

User Backup creates USER.PQI files. These files are read-only—you cannot edit their contents.



Did you know ...

Everything added to the drive since the last User Backup is lost when you perform a User Restore.

Using the Recovery CD

When you restart your computer with the Recovery CD in the drive, the following menu is displayed:

Option	Description
Emergency Diskette	Creates a recovery diskette which stores the software option information that came with your computer. This information is needed to restore your computer to the condition it was in when you first unpacked it.
User Backup	Creates a backup of the C drive. The backup is stored on the D drive in USER.PQI files.
User Restore	Extracts the data in the USER.PQI files from the D drive and restores the desktop to the settings existing at the time of your last User Backup. Any files, data, or programs you added after your last User Backup are deleted.
Factory Restore	Restores the computer to its original factory condition. You will need to re-enter your factory registration information again, and you may be prompted to insert your emergency disk. Any files, data, or programs you added after receiving your computer are deleted.
Exit	Exits the Recovery CD.

Compaq Support

If you have a computer problem or question, check the following resources for answers:

- Review the “Need Some Help?” chapter in this guide for suggestions to solve the problem.
- Press the **Help ?** button on the keyboard to access service and support information for your Presario, find information about your computer and computer-related peripherals, and access links to online technical help.
- Visit the Compaq Web Site at:

www.compaq.com/consumersupport
- Contact Compaq Technical Support at the telephone number listed in your Certificate of Warranty.

Troubleshooting

If a solution does not solve your problem, try all solutions for the symptom or try the solution a second time.

Before contacting Technical Support, keep in mind that the information needed to correct the problem may be at your fingertips. Try pressing the **Help ?** button on the keyboard. This button accesses important service-and-support information and tools.

Information in this section is divided into three areas: Symptom, Problem, and Solution.

The **Symptom** line describes the symptom or warning message for the type of problem you are having. The **Problem** column identifies one or more reasons why the symptom may have occurred. The **Solution** column describes what you should do to try to solve the problem.

Note: Some of the symptoms listed for certain troubleshooting problems will not apply to your computer. For problems relating specifically to the monitor or printer, refer to the documentation that came with the equipment.

Audio

Symptom	Problem	Solution
No sound	Speaker cables are not properly connected.	Shut down your computer using the normal shutdown procedure. Reconnect the speakers. Refer to the Quick Set-Up poster for instructions.
	Volume is muted.	On the Windows taskbar, click the Volume  icon and clear the Mute check box.
	Computer is in Sleep mode. This mode is identified when the Power Status light on your Internet keyboard is lit in amber.	See Waking Your Computer in the chapter “Using Your Computer” in this guide.

CD-ROM, CD-RW, or DVD-ROM

Symptom	Problem	Solution
CD-ROM, CD-RW, or DVD-ROM drive cannot read a disc or takes too long to start.	CD has been inserted upside-down.	Re-insert the CD with the label facing up.
	The DVD-ROM drive takes longer to start because it has to determine the type of media being played, such as audio or video.	Wait at least 30 seconds to let the DVD-ROM drive determine the type of media being played. If the disc still does not start, read the other solutions listed in this topic.
	CD or DVD disc is dirty.	Clean CD or DVD with a CD cleaning kit, available from most computer stores.
	Windows does not detect CD-ROM or DVD-ROM driver.	<ol style="list-style-type: none"> 1. On the Windows taskbar, click Start, point to Settings, and then click Control Panel. The Control Panel window is displayed. 2. Double-click the System  icon. The System Properties dialog box is displayed. 3. Click the Device Manager tab. 4. Click the plus sign + next to the CD or DVD drive, and select the installed driver. 5. Click the Remove button, and click OK twice. 6. Restart your computer, and let Windows detect the CD or DVD driver.
Recording audio CDs is difficult or impossible.	Wrong or poor quality media type.	<p>Verify that you are using the correct media for the drive.</p> <p>Try a different brand of media. Quality varies widely between manufacturers.</p>

Note: See online Help in the Easy CD Creator software for detailed troubleshooting tips.

Disk Drive

Symptom	Problem	Solution
Not reading drive: "Abort, Retry, Fail?" message is displayed.	A non-formatted disk has been inserted.	To format the disk: <ol style="list-style-type: none"> 1. Double-click the My Computer  icon on the Windows desktop. 2. Select the disk (A) drive. 3. Click File, and point to Format. 4. Select the desired options, and click Start to begin formatting the disk.
	Disk is damaged.	Replace the disk with a new one.
"Non-system disk or disk error" message is displayed.	A disk that does not contain the system files needed to start your computer has been inserted in the drive.	When drive activity stops, remove the disk and press the Spacebar . The computer should start up.
	Disk error has occurred.	Restart your computer by pressing the Start/Reset button. If the error message returns, see the next problem "System files have been damaged."
	System files have been damaged.	<ol style="list-style-type: none"> 1. Insert a start-up disk in the disk drive. 2. Restart your computer. 3. At the A:> prompt, type SYS C: and press the Enter key. 4. The following message is displayed: SYSTEM TRANSFERRED. This task restores the system files to the hard disk. 5. Restart your computer.
	Hard drive has failed.	Call Compaq Technical Support. Refer to your Certificate of Warranty for details.

Symptom	Problem	Solution
Disk drive light stays on.	Disk has been improperly inserted.	Remove the disk and reinsert it as follows: Insert the edge with the sliding cover into the drive, face up, and push the disk all the way in until it stops.
	Disk is damaged.	Remove the disk and insert a new disk. If the problem persists, run the Windows Maintenance Wizard to repair the drive: <ol style="list-style-type: none"> 1. From the Windows taskbar, click the Start button. 2. Point to Programs, then Accessories, then System Tools, and then click Maintenance Wizard. 3. Select Perform maintenance now. 4. Click OK.
Disk drive cannot save information to disk.	Disk is not formatted.	To format the disk: <ol style="list-style-type: none"> 1. On the Windows desktop, double-click the My Computer  icon. 2. Select the disk (A) drive. 3. Click File, and point to Format. 4. Select the desired options, and click Start to begin formatting the disk.
	Disk is write-protected.	Slide the write-protection tab to the unlocked position on the disk.
	Disk is full or the file is too big.	Use another disk or compress the file to reduce the size.
	Disk is damaged.	Replace the damaged disk.

Symptom	Problem	Solution
Disk drive cannot save information to disk, cont.	File Save command not properly executed.	When saving information to the disk drive, verify that you are using the correct drive letter.
Disk drive cannot read a disk.	Disk drive has failed.	Call Compaq Technical Support. Refer to your Certificate of Warranty for details.
	Disk is not formatted.	To format the disk: <ol style="list-style-type: none"> 1. On the Windows desktop, double-click the My Computer  icon. 2. Select the disk (A) drive. 3. Click File, and point to Format. 4. Select the desired options, and click Start to begin formatting the disk.

Display (Monitor)

Symptom	Problem	Solution
Screen is blank, and monitor power light is not lit.	Monitor power cable is not connected to the monitor or to the wall outlet.	Reconnect the power plug on the back of the monitor and on the wall outlet.
	Monitor is not turned on.	Press the Power button on the front of the monitor.
Screen is blank.	Monitor connector cable is not properly connected to the back of the computer.	Inspect the monitor video connector for bent pins. If no pins are bent, reconnect the monitor connector cable on the back of the computer.
	Screen saver is enabled.	Press any key or move the mouse to make the screen display visible again.
	Computer is in Sleep mode, as shown on the keyboard LED panel.	See Waking Your Computer in the “Using Your Computer” chapter in this guide.
	If you have a flat-panel monitor (available on select models), you may need a Digital Video Interface and connector.	Refer to your Certificate of Warranty for details.

Hard Drive

Symptom	Problem	Solution
Computer seems to be locked up.	Program in use has stopped responding to commands.	Attempt a normal Windows shutdown. If this fails, press the Power button for four or more seconds to turn off the power. To restart your computer, press the Power button again.
Hard drive error message is displayed.	Part of hard drive has failed.	Run the Windows Maintenance Wizard to repair the drive: <ol style="list-style-type: none"> 1. From the Windows taskbar, click the Start button. 2. Point to Programs, then Accessories, then System Tools, and then click Maintenance Wizard. The Maintenance Wizard is displayed. 3. Select Perform maintenance now. 4. Click OK.
Hard drive fault protection error message is displayed.	Part of the hard drive is about to fail or could already have failed.	Call Compaq Technical Support. Refer to your Certificate of Warranty for details.

Internet Access

Symptom	Problem	Solution
Cannot connect to the Internet.	Internet Service Provider (ISP) account is not set up properly.	Verify Internet settings or contact your ISP for assistance.
	Modem is not set up properly.	Reconnect the modem, verifying the following connections: telephone line to telephone (for external phone sets) and telephone line to wall jack (from computer to wall).
	Web browser is not set up properly.	Verify that the Web browser is installed and set up to work with your ISP.
Cannot automatically launch Internet programs.	You must log in to your ISP before some programs will start.	Log in to your ISP and launch the desired program.
Internet takes too long to download Web sites.	Modem is not set up properly.	<p>Verify that the correct modem speed and COM port are selected:</p> <ol style="list-style-type: none"> 1. Click Start and point to Settings. 2. Click Control Panel. The Control Panel window is displayed. 3. Double-click Modems. Windows detects the modem(s) you have installed. 4. Click the Properties button. An identification window is displayed. 5. Verify that the correct modem port is set and the maximum speed of your modem is selected. Reset these settings if necessary. 6. Click OK to close the identification window. 7. Click Close to close the Modems Properties Window. 8. Click the Close <input checked="" type="checkbox"/> button in the upper-right corner of the Control Panel window to return to the Windows desktop.

Keyboard and Scroll Mouse

Symptom	Problem	Solution
Keyboard commands and typing are not recognized by the computer.	Keyboard connector is not properly connected.	<ol style="list-style-type: none"> 1. On the Windows taskbar, click the Start button. 2. On the Start menu, click Shut Down... The Shut Down Windows dialog box is displayed. 3. Select the Shut down option. 4. Click OK. 5. After the shutdown is complete, reconnect the keyboard to the back of your computer and restart your computer.
	Program in use has stopped responding to commands.	Shut down your computer using the mouse. If your mouse cannot activate a shutdown, refer to the problem on the next page: "Mouse connector is not properly plugged into the back of the computer."
	Keyboard needs repair.	Refer to your Certificate of Warranty for details.

Symptom	Problem	Solution
Mouse does not respond to movement or is too slow.	Mouse connector is not properly plugged into the back of the computer.	<p>Shut down your computer using the keyboard:</p> <ol style="list-style-type: none"> 1. Press the Ctrl and Esc keys at the same time to display the Start menu. 2. Use the up or down arrow key to select Shut Down..., and then press the Enter key. 3. Select the Shut down option. You may need to use the up or down arrow key. 4. Press the Enter key to select OK. 5. After the shutdown is complete, plug the mouse connector into the back of your computer (or the keyboard) and restart your computer.
	Program in use has stopped responding to commands.	Shut down your computer using the keyboard. Refer to the preceding problem "Mouse connector is not properly plugged into the back of the computer" for details about shutting down using the keyboard.
Mouse will only move vertically or horizontally.	Mouse roller ball is dirty.	Remove roller ball cover from bottom of mouse and clean with mouse cleaning kit available from most computer stores.
	Mouse needs repair.	Call Compaq Technical Support. See your Certificate of Warranty for details.

Wireless Wheel Mouse

Symptom	Problem	Solution
Mouse does not work after installation or is not detected.	Receiver is not connected properly.	Try unplugging then reconnecting the receiver cable to your computer. The receiver cable goes into the computer's USB port or PS/2 mouse port.
	Batteries are not installed properly.	Reinstall the batteries according to the diagram inside the battery compartment.
	Communication between receiver and mouse not established.	Press the Connect button on the receiver, then press the Connect button under the mouse. See step 6 in the "Compaq/Logitech Wireless Wheel Mouse" section for more information.
Poor reception.	Receiver too close to other electrical devices.	Place the receiver at least 8 inches or 20 centimeters away from other electrical devices, such as the computer, the computer monitor, or external storage devices.
		If you are working on a metallic surface, try turning the receiver on its side.
Mouse stops functioning.	Batteries are low.	Replace the batteries.

Memory

Symptom	Problem	Solution
Insufficient memory message is displayed.	All memory in the computer is being used by open programs, and memory is needed for a desired task.	To avoid Windows running unnecessary programs automatically at startup: <ol style="list-style-type: none"> 1. From the Windows desktop, click the Start button. 2. Select Run. 3. In the Open box, type MSCONFIG. 4. Click OK. The <i>System Configuration Utility</i> dialog box is displayed. 5. Click the Startup tab, and clear the check box(es) for any unnecessary programs. 6. Close one or more programs, and restart Windows to recover memory. If the error message is displayed again, repeat the preceding steps and close one or more programs.

Power

Symptom	Problem	Solution
Computer will not turn on.	Line voltage selection switch is not in the proper position for your region (115V/230V).	Set the line voltage selection switch to the correct setting for your region, or call Compaq Technical Support for assistance. Refer to your Certificate of Warranty for details.
	Wall outlet is defective.	Test the outlet by connecting a different electrical device to the outlet.
“Illegal Operation has Occurred” error message is displayed.	Software being used is not Microsoft-certified for your version of Windows.	Verify that the software is certified by Microsoft for your version of Windows (see program packaging for this information).

Symptom	Problem	Solution
“Illegal Operation has Occurred” error message is displayed (continued).	Configuration files are corrupt.	<p>If possible, save all data, close all programs, and restart your computer. If the error message returns, you may need to back up your data files and use the Recovery CD. Refer to the Recovery CD table in this chapter for details.</p> <p>▲ Caution: Factory Restore reformats your hard drive; all data files will be lost.</p>
Computer will not start.	System files may have been damaged. You will need to insert a system startup disk or the Windows StartUp disk to restart your computer.	<ol style="list-style-type: none"> 1. Insert a startup disk in the disk drive. 2. Restart your computer. 3. At the A:> prompt, type SYS C: and press the Enter key. The following message is displayed: SYSTEM TRANSFERRED. This task restores the system files to your hard drive. 4. Remove the disk from the A drive and restart your computer. <p>If this procedure does not restart your computer, call Compaq Technical Support. Refer to your Certificate of Warranty for details.</p>
	Wrong memory modules were used in the upgrade, or memory modules were installed in the wrong location.	Verify that you installed your memory modules correctly by calling Compaq Technical Support. Refer to your Certificate of Warranty for details.
	Hard drive is damaged.	Call Compaq Technical Support. Refer to your Certificate of Warranty for details.

Index

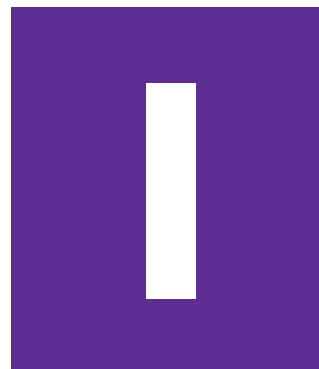

A

- Adaptec Easy CD Creator 2-20
- Add/Remove Programs 4-4
- AOL
 - connecting with 3-4
 - reading e-mail 3-9
 - searching the Web 3-4
 - sending e-mail 3-8
 - setting Internet buttons 3-3
- arrow keys 2-3
- audio
 - playing a CD 2-18
 - playing digital files 4-3
- autoscrolling 2-14

B

- backups 6-3
- browser 3-4
- buttons
 - See* keyboard

C

- CD/DVD-ROM control buttons 2-4
- CD-ROM drive
 - inserting a disc 2-17
 - playing an audio CD 2-18
 - removing a disc 2-18
 - upgrading 5-3
- CD-RW drive
 - creating CDs 2-20
 - inserting a disc 2-17
 - playing an audio CD 2-18
 - removing a disc 2-18
 - upgrading 5-3
- Compaq
 - Connection Helper 3-3
 - technical support 6-4
 - Web site 1-3
- Content Advisor 3-10
 - creating CDs 2-20

D

- disk
 - disk error 6-7
 - drive failure 6-7
 - reformatting 6-7
 - using 2-16
- downloading software 4-5
- drive
 - CD-ROM 2-16
 - CD-RW 2-16
 - disk 2-16
 - DVD-ROM 2-16
 - hard 2-16
- DVD-ROM drive
 - inserting a disc 2-17
 - playing a movie 2-19
 - playing an audio CD 2-18
 - removing a disc 2-18
 - upgrading 5-3

E

- e-mail
 - address criteria 3-6
 - AOL 3-8
 - defined 3-5
 - extensions 3-6
 - Hotmail 3-5
 - ISP 3-6
 - Outlook Express 3-5
 - reading messages 3-9
 - receiving 3-9
 - sending with AOL 3-8
 - sending with Outlook Express 3-7
 - undeliverable message 3-5
 - writing messages 3-5
- emergency diskette 6-3
- energy saver 2-9

F

- factory restore 6-3
- function keys 2-3

G

- games 4-3

H

- hard drive
 - failure 6-7
 - problems with 6-10
 - using 2-16
- Help button 2-7
- helpful hints 6-2
- Hotmail 3-5
- hyperlink 3-2

I

- install
 - downloaded files 4-5
 - software 4-4
- Instant E-mail button 3-9
- internal components 5-2
- Internet
 - accessing favorite sites 2-7
 - defined 3-2
 - downloading files 4-5
 - parental controls 3-10
 - problems with 6-11
 - restricting content 3-10
 - Web browser 3-4

Internet buttons

- Activity 2-5
- E-mail 2-5
- Entertainment 2-5
- Instant Internet 2-5
- Retail/Affinity Central 2-5
- Search 2-5
- setting to AOL 3-3

Internet Service Provider (ISP)

- establishing 3-2
- problems with account 6-11
- server name 3-6
- user name 3-6

K

keyboard

- arrow keys 2-3
- CD/DVD Control buttons 2-4
- Easy Access buttons 2-6
- function keys 2-3
- Help button 2-7
- Instant E-mail button 3-5
- Internet Zone buttons 2-6
- main keys 2-3
- My Program button 2-8
- numeric keys 2-3
- Quick Launch Web buttons 2-7
- Sleep button 2-9
- Smart Credit Card 2-11
- status lights 2-10
- volume buttons 2-8

L

Logitech

- Internet video camera 2-21
- wireless mouse 2-12

M

- memory 5-5
- monitor
 - flat-panel 6-9
 - problems with 6-9
- mouse
 - autoscrolling 2-14
 - clicking 2-13
 - double-clicking 2-13
 - scrolling 2-13
 - wireless 2-12
- movies 2-19
- MP3 files 4-3
- My Program button 2-7, 2-8

N

- Netscape Navigator 3-4
- numeric keys 2-3

O

- Outlook Express 3-5
 - sending e-mail 3-7
 - setting up 3-5

P

- parental controls 3-10
- ports 2-2
- power
 - button 2-2
 - problems with 6-16
- printing
 - documents 4-2
 - from the Internet 4-2
 - options 4-2
- problems
 - See troubleshooting*

Q

Quick Launch Web buttons 2-7

R

Recovery CD

emergency diskette 6-3

factory restore 6-3

user backup 6-3

user restore 6-3

removing programs 4-4

S

SDRAM 5-5

service and support 6-4

sleep mode 2-9

software

installing from disc 4-4

installing from Internet 4-5

speakers

Audio In port 2-15

cassette player 2-15

CD player 2-15

MP3 player 2-15

turning on 2-15

volume control 2-15

startup disk 6-16

status lights

caps lock 2-10

e-mail 2-10

num lock 2-10

scroll lock 2-10

sleep 2-10

surge protector 1-4

T

troubleshooting

audio 6-5

CD-ROM drive 6-6

CD-RW drive 6-6

checklist 6-2

Compaq support 6-4

disk drive 6-7

DVD-ROM drive 6-6

hard drive 6-10

Internet access 6-11

keyboard 6-12

memory 6-15

monitor 6-9

power 6-16

Recovery CD 6-3

scroll mouse 6-12

wireless mouse 6-14

TV out plug 2-2

U

upgrading components 5-2

user backup 6-3

user restore 6-3

V

video camera 2-21

W

waking your computer 2-9

warranty 1-3

World Wide Web

See Internet