

hp pavilion home pc warranty and support guide

- ✓ 1 year parts and labor
- ✓ 1 year technical telephone support
- ✓ 24 hours a day, 7 days a week

what's inside:

- ✓ where to get help
- ✓ warranty and license information
 - ✓ declaration of conformity
 - ✓ operating specifications
- ✓ regulatory and safety information



i n v e n t

Before contacting HP Customer Support Center, it's important to have the following information handy. Please take a moment to write down your product information for future reference.

Product Name:
Model Name:
Serial Number:
Date of Purchase:
Operating System Type & Revision:

You may also want to record the following information:

- Applicable error messages
- Additional third-party hardware and/or software installed
- Any detailed, specific questions

Don't Forget to Register!

Registration is quick, easy, and has its benefits. Registration offers you access to subscriptions and notifications such as:

- E-mail updates containing notifications about product enhancements, the most recent support alerts, and driver updates specific to the product(s) you own.
- The HP newsgam, our monthly online magazine packed full of product news, support tips, project ideas, and much more.

Visit us at <http://register.hp.com>

Where to Get Help

Follow these steps when you need help from HP:

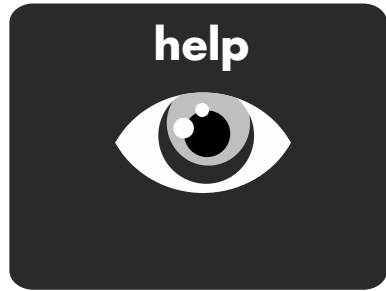

- 1** Check the setup poster and the *Quick Start Guide* for help with setting up your PC.
- 2** For faster help, be sure to register your HP Pavilion home PC by e-mail, on the Web at <http://www.register.hp.com> or by phone.
- 3** Use Help on your PC to get help with your hardware and software. Click **Start** and then click **Help and Support**.
- 4** For help online, go to the HP Support Web site at <http://www.hp.com/support>
- 5** If you have not solved the problem, call the HP Customer Care Center at **1-800-HP-INVENT** (U.S. & Canada).

HP Support Web site:

<http://www.hp.com/support>

HP Customer Care Center:

1-800-HP-INVENT (U.S. and Canada)

Hours: 24 hours, 7 days

HP Registration Web site:

<http://register.hp.com>

Software Support

Software Title – Company	Phone – Web Address
America Online	U.S.: 888-346-3704 Canada: 888-265-4357 www.aol.com
ArcSoft	www.arcsoft.com
AT&T WorldNet	800-400-1447 www.att.net
CompuServe 2000	800-944-9871 www.compuserve.com
Corel	www3.corel.com
Detto Technologies	866-338-8663 www.detto.com
Disney's Blast Online	972-389-3970 www.disney.com
EarthLink	dial-up customer service 800-890-6356 dial-up technical support 800-890-5128 DSL customer service and technical support 888-829-8466 www.earthlink.net
InterVideo (only DVD-ROM models)	www.intervideo.com
MusicMatch	www.musicmatch.com
Prodigy Internet Services	800-213-0992 www.prodigy.com
Quicken Basic (Intuit)	900-555-4688 www.intuit.com
Veritas (only CD-RW and DVD+RW/+R models)	www.veritas.com
Yahoo! – User Support	www.yahoo.com

Warranty and License Information

Contacting HP Customer Care

HP Customer Care provides fast, friendly, and effective expert advice for all your HP products. If you have a question or if a problem arises, we offer extensive service and support options around the clock to better handle your needs. For the fastest access to product information and assistance, go to: www.hp.com/support

HP Support Process

HP offers a wide variety of service and support options which are available around the clock for HP customers with products that are either in or out of warranty. If you have a question or a problem arises, for the fastest service we suggest that you seek assistance from HP service and support in the following manner:

- 1 Use the Help and Support features that are installed with your product and refer to your product documentation for specific instructions and troubleshooting information.
- 2 Visit the HP online service and support at www.hp.com/support. HP online service and support is available to all HP customers for the life of their HP products. It is always available and is your fastest source for up-to-date product information and expert assistance that includes:
 - fast access to qualified online support specialists
 - software and driver updates for your product
 - valuable product and troubleshooting information for common problems
 - proactive product updates, support alerts, and HP newsgroups are available when you register your product
- 3 Contact HP Customer Care by phone 24 hours a day, seven days a week in both English and Spanish (U.S. Only) via 1-800-HP-INVENT. Canadian customers can reach us at the same number for support in both English and French. When you call please have your product model number, serial number, and date of purchase available. Telephone support is free during your limited warranty period.

When should I contact HP online service and support?

For many common problems and requests, HP online service and support is your fastest link to up-to-date product information and expert assistance. Visit www.hp.com/support to:

- download current software and drivers for your product
- troubleshoot common printing problems
- find user manuals and documentation for your product

When should I contact HP phone service and support?

When your problem cannot be solved through HP online service and support, qualified support specialists are available 24 hours a day via 1-800-HP-INVENT to provide expert assistance. Call HP Customer Care when:

- You either do not have Internet access, or cannot connect to the Internet to visit www.hp.com/support

- Your product “quick help” does not identify or help solve your problem
- There is obvious damage or a mechanical breakdown with your product rendering it inoperable

Note: Support options, availability and hours vary by product, country/region, and language and are subject to change.

And, if Necessary: Get Repair

Consumer Replaceable Parts

You can easily replace many of the HP Pavilion parts yourself. This is the fastest method of repair, as many times we can send the part directly to your home or business in a few days. Detailed instructions are included to guide you through an easy repair. We pay the shipping and handling. This service is free for the duration of the hardware warranty period.

In some cases, HP will ask for a credit card as collateral for the part and will charge you for the retail price of the part if the failed part is not returned within thirty (30) days.

Send-In Repair Service

Your PC can be shipped to the HP Central Repair Center. We pay for the round-trip shipping and handling. This service is free for the duration of the hardware warranty period.

There are a few limitations and exclusions to this warranty (as well as some important details) and you'll find them described, in legal language, beginning on the next page.

Carry-In Service

You also have the option of taking your PC to a retailer who is an HP Authorized Service Provider. The ASP can facilitate the service on your PC. Visit www.hp.com/us/support for the nearest sales and authorized service office.

HP 3rd Party Support

3rd Party Support is the new one-stop support solution for our home and home office customers within the U.S.

If you have a support question about any aspect of your computer, peripherals, software, Internet connection, computer games, etc., just call us at (1) 208-333-3897. Even if your question is about a product or service not provided by HP, for a small fee*, we will do our best to get you up and running again.

Terms and conditions:

HP 3rd Party Support will provide all commercially reasonable efforts to resolve customer issues not covered by the existing warranty. The cost to the customer is \$34.99 per incident. To contact HP 3rd Party Support use the customer support number, (1) 208-333-3897, and select HP 3rd party support or tell your technical adviser.

HP Out-of-Warranty Support Options

Even after your warranty has ended, HP can still provide you with service and support options.

- For Visa and MasterCard holders in the United States or calls from Canada, please call 1-800-HP-INVENT. The fee is US\$30* per call, charged to your Visa or MasterCard.

*Prices are subject to change without notice and may vary based on your product.

Recycle – HP Planet Partners

HP is sensitive to the environment and has a program, Planet Partners, to make it simple for us to reclaim your old product for recycling. HP will help you recycle your old equipment even if it is not an HP product; we take back all makes and models. Visit our Web site to find out how easy it is to recycle: www.hp.com/recycle

Protect Your Investment

Obtaining a Warranty Upgrade

Upgrade your standard factory warranty to three years with the Care Pack. Service coverage begins on product purchase date and you must purchase the pack within the first 180 days after product purchase. The hardware service offering will be determined based on the outcome of system self-test programs run by the customer through the initial call to Customer Care.

For more information please visit <http://www.hp.com/go/hpsupportpack> or call 1-888-999-4747.

HP Installation Services

Did you know HP offers an installation service for all HP Pavilion home PCs? An HP-approved technician will come to your home or office to set up and test your PC and connect it to your printer. We will also make sure the connection to your Internet service provider, if you have one, is up and running.

HP installation services can also provide you with various levels of PC training and orientation to help you get the maximum satisfaction and benefit out of your new HP Pavilion.

For more information or to purchase the HP installation service, please call 1-800-HP-INVENT (U.S. only).

The Legal Language

Hewlett-Packard Limited Warranty Statement

DURATION OF LIMITED WARRANTY

Hardware:

Original Systems —	1 year
Technical phone assistance to diagnose potential hardware issues —	1 year

HP warrants to you, the end-user customer, that HP hardware, accessories, and supplies will be free from defects in materials and workmanship after the date of purchase —

Original Systems —	1 year
--------------------	--------

If HP receives notice of such defects during the warranty period, HP will replace products that prove to be defective. Replacement (e.g., keyboard, monitor, mouse, etc.) may be either new or like new. HP warrants to you that HP software will not fail to execute its programming instructions after the date of purchase, for 30 (thirty) days, due to defects in material and workmanship when properly installed and used. If HP receives notice of such defects during the warranty period, HP will replace software media, which does not execute its programming instructions due to such defects.

HP warrants the operation of a network interface card (NIC) only if factory preinstalled by HP, as follows: HP will make sure the correct drivers are installed; HP will make sure that the HP Pavilion recognizes the NIC. NO CONNECTIVITY ISSUES ARE SUPPORTED.

HP does not warrant that the operation of HP products will be uninterrupted or error-free. If HP is unable, within a reasonable time, to repair any product to a condition as warranted, you will be entitled to a refund of the purchase price upon prompt return of the product. Refunds within the first 3 months of ownership will be refunded at 100% of purchase price. Refunds within 3–6 months of ownership will be refunded at 85% of purchase price. Refunds within 6–9 months of ownership will be refunded at 55% of purchase price. Refunds within 9–12 months will be refunded at 35% of purchase price.

HP products may contain remanufactured parts, which are equivalent to new in performance or may have been subject to incidental use.

Warranty does not apply to defects resulting from (a) improper or inadequate maintenance or calibration, (b) software, interfacing, parts, or supplies not supplied by HP, (c) unauthorized modification or misuse, (d) computer viruses of any origin, (e) operation outside of the published environmental specifications for the product, (f) improper site preparation or maintenance, or (g) unplanned acts of nature, such as floods, tornadoes, lightning strikes, hurricanes, or earthquakes.

HP MAKES NO OTHER EXPRESS WARRANTY OR CONDITION WHETHER WRITTEN OR ORAL. TO THE EXTENT ALLOWED BY LOCAL LAW, ANY IMPLIED WARRANTY OR CONDITION OF MERCHANTABILITY, SATISFACTORY QUALITY, OR FITNESS FOR A PARTICULAR PURPOSE IS LIMITED TO THE DURATION OF THE EXPRESS WARRANTY SET FORTH ABOVE. Some countries/regions, states, or provinces do not allow limitations on the duration of an implied warranty, so the above limitation or exclusion might not apply to you. This warranty gives you specific legal rights and you might also have other rights that vary from country/region to country/region, state to state, or province to province.

HP's limited warranty is valid in any country/region or locality where HP has a support presence for this product and where HP has marketed this product. The level of warranty service you receive may vary according to local standards. HP will not alter form, fit, or function of the product to make it operate in a country/region for which it was never intended to function for legal or regulatory reasons.

TO THE EXTENT ALLOWED BY LOCAL LAW, THE REMEDIES IN THIS WARRANTY STATEMENT ARE YOUR SOLE AND EXCLUSIVE REMEDIES. EXCEPT AS INDICATED ABOVE, IN NO EVENT WILL HP OR ITS SUPPLIERS BE LIABLE FOR LOSS OF DATA OR FOR DIRECT, SPECIAL, INCIDENTAL, CONSEQUENTIAL (INCLUDING LOST PROFIT OR DATA), OR OTHER DAMAGE, WHETHER BASED IN CONTRACT, TORT, OR OTHERWISE. Some countries/regions, states, or provinces do not allow the exclusion or limitation of incidental or consequential damages, so the above limitation or exclusion may not apply to you.

The above warranty is transferable upon sale.

Customer Responsibilities

You may be required to run HP-supplied diagnostic programs before replacement component (e.g., keyboard, monitor, mouse, etc.) is dispatched. You are responsible for the security of your proprietary and confidential information and for maintaining a procedure external to the products for reconstruction of lost or altered files, data, or programs. You should back up all data on your system before calling the HP Customer Care Center. Additionally, the customer is responsible for removing any components that were added after the purchase of the system. HP will not be responsible for components that the customer doesn't remove.

Obtaining Hardware Warranty Repair Service

For the duration of the hardware warranty period, hardware repair service includes Consumer Replaceable Parts Service, Send-in Repair Service, and Carry-In Service (ASP Retailer). To obtain hardware warranty service, call HP's Customer Care Center at 1-800-HP-INVENT (U.S. and Canada).

Consumer Replaceable Parts Service

Components such as the keyboard, mouse, hard disc drive, and CD-ROM, may be serviced through expedited part shipment. In this event, HP will send you the component with instructions on replacement.

In some cases, HP will ask for a credit card as collateral for the part and will charge you for the retail price of the part if the failed part is not returned within thirty (30) days.

Send-In Repair Service

Service can be obtained by shipping your PC to the HP Central Repair Center. The PC will be repaired and returned to you.

Carry-In Service

Service can be obtained by taking your PC to an HP Authorized Service Provider.

HP Software Product License Agreement

The following License Terms govern your use of the accompanying Software unless you have a separate signed agreement with HP.

ATTENTION: USE OF THE SOFTWARE IS SUBJECT TO THE HP SOFTWARE LICENSE TERMS SET FORTH ON THE FOLLOWING PAGE; USING THE SOFTWARE INDICATES YOUR ACCEPTANCE OF THESE LICENSE TERMS. IF YOU DO NOT ACCEPT THESE LICENSE TERMS, YOU MAY RETURN THE SOFTWARE FOR A FULL REFUND. IF THE SOFTWARE IS BUNDLED WITH ANOTHER PRODUCT, YOU MAY RETURN THE ENTIRE UNUSED PRODUCT FOR A FULL REFUND.

The HP Software Product License Agreement will govern all Software, which is provided to you with the exception of Microsoft Software. Microsoft Products are licensed to you under the Microsoft End User License Agreement (EULA) contained in the Microsoft documentation online.

License

GRANT — HP grants you a license to use one copy of the Software. “Use” means storing, loading, installing, executing, or displaying the Software. You may not modify the Software or disable any licensing or control features of the Software. If the Software is licensed for “concurrent use,” you may not allow more than the maximum number of authorized users to use the Software concurrently.

OWNERSHIP — The Software is owned and copyrighted by HP, its subsidiaries, or its third-party suppliers. Your license confers no title to, or ownership in, the Software and is not a sale of any rights in the Software. HP’s third-party suppliers may protect their rights in the event of any violation of these License Terms.

Copies

ADAPTATIONS — You may make copies or adaptations of the Software only for archival purposes or when copying or adaptation is an essential step in the authorized Use of the Software. You must reproduce all copyright notices in the original Software on all copies or adaptations. You may not copy the Software onto any public network.

If your computer was shipped with a Recovery CD, (i) the Recovery CD and/or Support Utility software may be used only for restoring the hard disk of the HP computer system with which the Recovery CD originally was provided, and (ii) if separate EULA(s) are included with your computer for any other Microsoft products which are included on the Recovery CD, those Microsoft products are subject to the terms of their respective EULA(s).

No Disassembly

DECRYPTION — You may not disassemble or decompile the Software unless HP’s prior written consent is obtained. In some jurisdictions, HP’s consent may not be required for limited disassembly or decompilation. Upon request, you will provide HP with reasonably detailed information regarding any disassembly or decompilation. You may not decrypt the Software unless decryption is a necessary part of the operation of the Software.

TRANSFER — Your license will automatically terminate upon any transfer of the Software. Upon transfer, you must deliver the Software, including any copies and related documentation, to the transferee. The transferee must accept these License Terms as a condition to the transfer.

TERMINATION — HP may terminate your license upon notice for failure to comply with any of these License Terms. Upon termination, you must immediately destroy the Software, together with all copies, adaptations, and merged portions in any form.

EXPORT REQUIREMENTS — You may not export or re-export the Software or any copy or adaptation in violation of any applicable laws or regulations.

Restricted Rights

RIGHTS — The Software and any accompanying documentation have been developed entirely at private expense. They are delivered and licensed as “commercial computer software” as defined in DFARS 252.227-7013 (Oct 1988), DFARS 252.211-7015 (May 1991), or DFARS 252.227-7014 (Jun 1995), as a “commercial item” as defined in FAR 2.101(a), or as “Restricted computer software” as defined in FAR 52.227-19 (Jun 1987) (or any equivalent agency regulation or contract clause), whichever is applicable. You have only those rights provided for such Software and any accompanying documentation by the applicable FAR or DFARS clause or the HP standard software agreement for the product involved.

(REV. 090502)

Declaration of Conformity

According to ISO/IEC Guide 22 and EN 45014

Manufacturer's Name: Hewlett-Packard Company
Manufacturer's Address: 10500 Ridgeview Ct.
Cupertino, CA 95015-4010
USA

declares that the product

Product Name: HP Pavilion Multimedia Personal Computer System
Model Number(s): 100 series, 300 series, 400 series, 500 series, 600 series,
700 series, 800 series, a000 series, t000 series, m000 series
Product Options: All

conforms to the following Product Specifications:

Safety: IEC 60950:1991 + A1, A2, A3, A4
EN 60950:1992 + A1, A2, A3, A4, A11
IEC 60825-1:1993 + A1/E 60825-1:1994 + A11 Class 1 (Laser/LED)

EMC: CISPR 22:1997/EN 55022:1998 Class B¹⁾
CISPR 24:1997/EN 55024:1998
IEC 61000-3-2:1995/EN61000-3-2:1995 + A14 — Harmonics
IEC 61000-3-3:1994/EN61000-3-3:1995 — Flicker
FCC Title 47 CFR, Part 15 Class B²⁾/ICES-003, Issue 2
AS/NZS 3548:1995 + A1 + A2:1997/CISPR 22:1993 +
A1 + A2:1996 Class B¹⁾

Telecom: TBR 21:1998, EG201 121:1998

Supplementary Information:

The product herewith complies with the requirements of the following Directives and carries the CE marking accordingly.

— the R&TTE Directive 1999/5/EC

- 1) The Product was tested in a typical configuration with Hewlett-Packard Personal Computer and peripherals.
- 2) This Device complies with Part 15 of the FCC Rules. Operation is subject to the following two conditions: (1) this device may not cause harmful interference, and (2) this device must accept any interference received, including interference that may cause undesired operation.

Hardware Quality Engineering Manager
Cupertino, CA, USA May, 2003

For Regulatory Compliance Information ONLY, contact:

North America Contact: Hardware Quality Engineering Manager
Hewlett-Packard, CPC
10500 Ridgeview Ct.
Cupertino, CA 95015-4010
USA
(Phone: 408-343-5000)

Operating Specifications

Electrical ratings:	Models: 100 series, 300 series, 400 series, 500 series, 600 series, 700 series, and 800 series, a000 series, t000 series, m000 series 100–127 V _~ /200–240 V _~ , 4/2 A, 50/60 Hz
Operating temperature:	5° to 35° C (On models with DVD+RW/+R drives, the operating temperature is 5° to 30° C)
Storage temperature:	-40° to 70° C
Operating humidity:	15 to 80% @ 26° C
Storage humidity:	90% @ 65° C (non-condensing)
Operating altitude:	0–2286 m
Storage altitude:	0–4572 m



Batteries are delivered with this product. When empty, do not throw them away but collect as small chemical waste.

Bij dit produkt zijn batterijen geleverd. Wanneer deze leeg zijn, moet u ze niet weggooien maar inleveren als KCA.

Regulatory and Safety Information



Warning: *The HP Pavilion is heavy; be sure to use ergonomically correct lifting procedures when moving the computer.*



Warning: *Electrostatic discharge (ESD) can damage disk drives, add-in cards, and other components. If an ESD station is not available, wear a wrist strap attached to a metal part of the computer. Place cards on a conductive foam pad or inside the conductive wrapper they came in; do not place the cards on top of the wrapper.*



Warning: *Do not operate the system with the cover removed. Always replace the cover before turning on the system.*



Warning: *Please read the "Additional Safety Information" located later in this document before installing and connecting your system to the electrical power system.*



Warning: *Using the wrong type of memory module could damage the system.*



Warning: *Do not pull the memory module out of the socket. Use the retaining clips to eject the module.*



Warning: *Do not overload the system by installing add-in cards that draw excessive current. The system is designed to provide 2 amps (average) of +5 V power for each board/card in the computer. The total +5 V current draw in a fully loaded system (one with all add-in card slots filled) must not exceed the total number of slots multiplied by 2 amps.*



Warning: *Be careful of the sharp edges on the expansion slot cover.*



Warning: *There is danger of an explosion if the battery is incorrectly replaced. Replace only with the same, or equivalent, type of battery. Discard used batteries according to the manufacturer's instructions.*

FCC Regulatory and Safety Information (USA Only)

Federal Communications Commission (FCC) Radio Frequency Interference Statement



Warning: This equipment has been tested and found to comply with the limits for a Class B digital device, pursuant to Part 15 of the FCC Rules. These limits are designed to provide reasonable protection against harmful interference in a residential installation. This equipment generates, uses, and can radiate radio frequency energy and, if not installed and used in accordance with the instructions, may cause harmful interference to radio communications. However, there is no guarantee that interference will not occur in a particular installation. If this equipment does cause harmful interference to radio or television reception, which can be determined by turning the equipment off and on, the user is encouraged to correct the interference by one or more of the following measures:

- **Reorient or relocate the receiving antenna.**
- **Increase the separation between the equipment and the receiver.**
- **Connect the equipment into an outlet that is on a circuit different from the receiver.**
- **Consult the dealer or an experienced radio/TV technician for help.**

Hewlett-Packard's system RFI and Radiated Immunity tests were conducted with HP-supported peripheral devices and HP-shielded cables, such as those you receive with your system. Changes or modifications not expressly approved by Hewlett-Packard could void the user's authority to operate the equipment. To comply with the limits for an FCC Class B computing device, always use shielded signal cables and the power cord supplied with this unit.

Consumer Information and FCC Requirements

Telephone Connection

- This equipment complies with Part 68 of the Federal Communications Commission rules. These rules permit this device to be directly connected to the telephone network. Standardized jacks are used for these connections. This equipment should not be used on party lines or coin lines.
- If this device is malfunctioning, it may also cause harm to the telephone network; this device should be disconnected until the source of the problem can be determined and until it has been repaired. If this is not done, the telephone company may temporarily disconnect your service.

- The telephone company may make changes in its technical operations and procedures. If such changes affect the compatibility or use of this device, the telephone company is required to give adequate notice of the changes.
- If the telephone company requests information on what equipment is connected to their lines, inform them of:
 - a The telephone number this unit is connected to
 - b The ringer equivalence number
 - c The USOC jack required: RJ-11C
 - d The FCC Registration Number

Items (b) and (c) are indicated on the label. The ringer equivalence number (REN) is used to determine how many devices can be connected to your telephone line. In most areas, the sum of the RENs on any one line should not exceed five (5.0). If too many devices are attached, they may not ring properly.

- In the event of equipment malfunction, Hewlett-Packard or an authorized HP Personal Computer Dealer Repair Center should perform all repairs. It is the responsibility of users requiring service to report the problem to HP's Consumer PC Division, or to one of our authorized agents. Service can be obtained by calling the HP Customer Care Center at 1-800 HP-INVENT.

Statement of Fax Branding

The Consumer Protection Act of 1991 makes it unlawful for any person to use a computer or other electronic device to send any message via telephone fax machine, unless it clearly contains: a margin at the top or bottom of each transmitted page or on the first page of the transmission, the date and time it is sent, identification of the business or other entity, or individual sending the message, the telephone number of the sending machine or such business, entity, or individual.

ENERGY STAR Compliance

Hewlett-Packard Pavilion PCs and Monitors marked with the ENERGY STAR® logo on the packaging box qualify with the U.S. Environmental Protection Agency's ENERGY STAR guidelines for energy efficiency.



Products with the ENERGY STAR label are designed to use less energy, help you save money on utility bills, and help protect the environment.

ENERGY STAR® is a registered trademark owned by the U.S. government.

Canada Department of Communications (DOC) Notice

Telephone Connection

The Canada Department of Communications label identifies certified equipment. This certification means that the equipment meets certain telecommunications network protective, operational, and safety requirements. The department does not guarantee the equipment will operate to the user's satisfaction.

Before installing this equipment, the user should ensure it is permissible to connect it to the facilities of the local communications company. The equipment must be installed using an acceptable method of connection. In some cases, the company's inside wiring associated with a single line individual service may be extended by means of a certified connector assembly (telephone extension cord). The customer should be aware that compliance with the above conditions may not prevent degradation of service in some situations.

Repairs to certified equipment should be made by an authorized Canadian maintenance facility designated by the supplier. Any repairs or alterations made by the user to this equipment, or equipment malfunctions, may give the telecommunications company cause to request that the user disconnect the equipment.

Users should ensure, for their own protection, that the electrical ground connections of the power utility, telephone lines, and internal metallic water pipe systems, if present, are connected together. This precaution may be particularly important in rural areas.



Warning: Users should not attempt to make such connections themselves, but should contact the appropriate electrical inspection authority or electrician, as appropriate.



Warning: The Load Number .9 assigned to each terminal device denotes the percentage of the total load to be connected to a telephone loop; this is used by the device to prevent overloading. The termination on a loop may consist of any combination of devices, subject only to the requirement that the sum of the Load Numbers does not exceed 100.



Warning: When using this device, basic safety precautions should always be followed to reduce the risk of fire, electric shock, and injury to persons, including the following:

- **Do not use this product near water, for example, near a bathtub, wash bowl, kitchen sink or laundry tub, in a wet basement or near a swimming pool.**
- **Avoid using this product during an electrical storm. There may be a remote risk of electric shock from lightning.**
- **Do not use this product to report a gas leak in the vicinity of the leak.**
- **Always disconnect the modem cable before opening the equipment enclosure or touching an uninsulated modem cable, jack or internal components.**
- **If this product was not provided with a telephone line cord, use only No. 26 AWG or larger telecommunication line cord in order to reduce the risk of fire.**
- **Do not plug a modem or telephone cable into the Network Interface Card (NIC) receptacle.**

SAVE THESE INSTRUCTIONS

DOC Statement (Canada Only)

This Class B digital apparatus meets all requirements of the Canadian Interference-Causing Equipment Regulations.

Additional Safety Information

This product has not been evaluated for connection to an "IT" power system (an AC distribution system with no direct connection to earth, according to IEC 60950).

This equipment meets the applicable Industry Canada Terminal Equipment Technical Specifications. This is confirmed by the registration number. The abbreviation, IC, before the registration number signifies that registration was performed based on a Declaration of Conformity indicating that Industry Canada technical specifications were met. It does not imply that Industry Canada approved the equipment.

AC Power Safety Warning



Warning: *Install the computer near an AC outlet. The AC power cord is your HP Pavilion's main AC disconnecting device and must be easily accessible at all times. For your safety, the power cord provided with your system has a grounded plug. Always use the power cord with a properly grounded wall outlet, to avoid the risk of electrical shock.*



Warning: *Your system is provided with a voltage select switch for use in a 115 or 230 VAC power system. The voltage select switch has been pre-set to the correct voltage setting for use in the particular country/region where it was initially sold. Changing the voltage select switch to the incorrect position can damage your PC and void any implied warranty.*



Warning: *To reduce the possibility of an electric shock from the telephone network, plug your computer into the AC outlet before connecting it to the telephone line. Also, disconnect the telephone line before unplugging your computer from the AC power outlet.*



Warning: *Always disconnect the modem cord from the telephone system before installing or removing your computer cover.*



Warning: *Do not operate the computer with the cover removed.*



Warning: *The power supply is not user-serviceable. To prevent damage to the power supply, have a qualified person repair or replace it. All other components are user-serviceable.*



Warning: For your safety, always unplug the system from its power source and from any telecommunications systems (such as phone lines), networks, or modems before performing any of the procedures described in this guide. Failure to do so may result in personal injury or equipment damage. Hazardous voltage levels are inside the power supply and modem of this product.

Lithium Battery Caution



Warning: The PC uses a lithium battery, type CR2032. There is danger of an explosion if the battery is incorrectly replaced. Replace only with the same, or equivalent, type recommended by the manufacturer. Dispose of used batteries according to the manufacturer's instructions.

Laser Safety Statement

Class 1 LED Product

The CD-ROM and DVD-ROM drives contain a laser system and are classified as a "Class 1 Laser Product" under a U.S. Department of Health and Human Services (DHHS) Radiation Performance standard according to the Radiation Control for Health and Safety Act of 1968.

Should the unit ever require maintenance, contact an authorized service location.



Warning: Use of controls, adjustments, or performance procedures other than those specified in the *Upgrading and Servicing the PC guide* may result in hazardous radiation exposure. To prevent direct exposure to laser beam, do not try to open the enclosure of the CD-ROM or DVD-ROM.

Laser Product Label

The following label or equivalent is located on the surface of HP laser products:



This label indicates that the product is classified as a CLASS 1 LASER PRODUCT. This label appears on a laser device installed in your product.

TV Antenna Connectors Protection

External Television Antenna Grounding

If an outside antenna or cable system is connected to the product, be sure the antenna or cable system is electrically grounded so as to provide some protection against voltage surges and built-up static charges. Article 810 of the National Electrical Code, ANSI/NFPA 70, provides information with regard to

proper electrical grounding of the mast and supporting structure, grounding of the lead-in wire to an antenna-discharge unit, size of grounding conductors, location of antenna-discharge unit, connection to grounding electrodes, and requirements for the grounding electrode.

Lightning Protection

For added protection of any Hewlett-Packard product during a lightning storm, or when it is left unattended and unused for long periods of time, unplug the product from the wall outlet and disconnect the antenna or cable system. This will prevent damage to the product from lightning and power line surges.

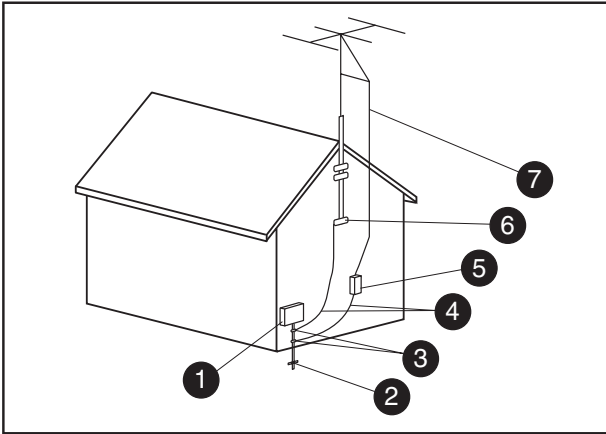

Antenna Grounding

Antenna Grounding

Reference	Grounding Component
1	Electric Service Equipment
2	Power Service Grounding Electrode System (NEC Art 250, Part H)
3	Ground Clamps
4	Grounding Conductors (NEC Section 810-21)
5	Antenna Discharge Unit (NEC Section 810-20)
6	Ground Clamp
7	Antenna Lead in Wire

Power Lines

An outside antenna system should not be located in the vicinity of overhead power lines or other electric light or power circuits, or where it can fall into such power lines or circuits.



Warning: When installing an outside antenna system, extreme care should be taken to keep from touching such power lines or circuits as contact with them could be fatal.

© 2003 Hewlett-Packard Development Company, L.P.
All rights reserved



5 9 9 0 - 5 6 6 3