

**hp pavilion home pc
warranty and
support guide**

- ✓ **where to get help**
- ✓ **warranty and license information**
- ✓ **declaration of conformity**
- ✓ **operating specifications**
- ✓ **regulatory and safety information**



i n v e n t

Where to Get Help

Follow these steps when you need help from HP:

- 1** Check the setup poster and the *Quick Start Guide* for help with setting up and using your PC.
- 2** For faster help, be sure to register your HP Pavilion home PC by using the Electronic Registration program on your PC or on the Web at <http://register.hp.com>
- 3** Use Help on your PC to get help with your hardware and software. Click **Start** and then click **Help and Support**.
- 4** For help online, go to the HP Customer Care Center Web site at <http://www.hp.com/support> for technical information or to get software updates.
- 5** If you have not solved the problem, call the HP Customer Care Center at the appropriate number below.

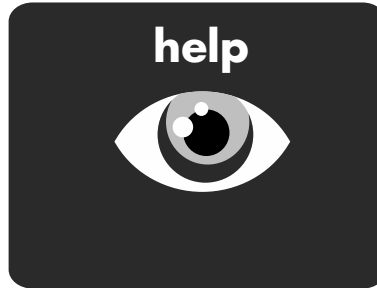

Australia: 1300 721 147
New Zealand: 0 800 441 147

Hours of Operation (local time):
Mon.–Fri. 10–9, Sat.–Sun. 10–4
Hours are subject to change without notice.

HP Support Web site:

<http://www.hp.com/support>

HP Registration Web site:

<http://register.hp.com>

Software Support

If you have questions about your software or ISP (Internet Service Provider), call or visit your software or ISP vendor's Web site. The appropriate number or Web address is listed below. Some of these Web addresses may be listed in the Favorites list found in your Internet Explorer browser. Phone and e-mail support may not exist if no information is given. For software not listed, the HP Customer Care Center provides 30-day limited support.

Internet Service Provider	Phone – E-mail Web Address
OzEmail (Australia)	132 884 support@ozemail.com.au www.ozemail.com.au/info/ frameset_techsupport.html
Xtra (New Zealand)	0800 22 55 98 xtrahelp@xtra.co.nz www.xtra.co.nz
Software Title – Company	Phone – E-mail Web Address
Acrobat Reader by Adobe	www.pacific.adobe.com/ support/main.html
ArcSoft Software Suite: Greeting Card Creator, Funhouse, & PhotoImpression	support@arcsoft.com www.arcsoft.com/support/ supportmain.html
GameChannel by WildTangent	hpdesktop_support@ wildtangent.com www.wildtangent.com
MusicMatch Jukebox	techsupp@musicmatch.com www.musicmatch.com/form/ support/tech
MyDVD by Sonic (w/DVD+RW/+R option only)	www.mydvd.sonic.com/ support
Norton AntiVirus 2003 by Symantec	www.symantec.com/region/ reg_ap/servsupp.html
RecordNow by Veritas (w/CD-RW or DVD+RW/+R option only)	support.veritas.com/menu_ ddProduct_MYCD.htm
ShowBiz by ArcSoft (w/FireWire® option only)	www.arcsoft.com/support/ supportmain.html
WinDVD by InterVideo (w/DVD-ROM or DVD+RW/+R option only)	support@intervideo.com www.intervideo.com

Warranty and License Information

To Our Valued Customer

Congratulations on your decision to purchase an HP Pavilion home PC! During development, the HP Pavilion must pass extensive quality tests to meet the rigorous standards that have made HP famous for quality and reliability.

All HP Pavilions go through a comprehensive quality test to ensure the PC is working correctly before it leaves our factory. In addition, we have placed a security seal on your PC to indicate that it has not been tampered with since it left our factory.

We know that expanding and upgrading are key benefits for all customers. We are proud to make this a key differentiator for our HP Pavilion and understand that you may wish to upgrade your PC to meet your specific needs.

Any hardware upgrades that you intend to do should only be done after you have completely set up your new HP Pavilion. Refer to the setup poster included with your system for help with setting up. If you have any problems setting up your system and turning it on, immediately contact the HP Customer Care Center listed earlier in this *Warranty and Support Guide*, and an HP Customer Representative will assist you. This must be done first before attempting to upgrade your system.

By breaking the security seal on the back of the HP Pavilion, you are confirming that the HP Pavilion was working properly before you attempted to upgrade your system. Once the security seal has been broken, your HP Pavilion is then, to the extent allowed by local law, covered under the terms and conditions listed in the following pages.

Thank you for choosing the HP Pavilion. We hope you enjoy discovering the exciting things you can do with it!

HP Customer Care

Easy to reach. Easy to use. Award-winning HP Customer Care is our promise to help you get the most from your HP Pavilion. Whether with tools located on your PC, from information on the Web, by phone, or through your local retailer, you'll find what you need.

Problems? HP Will Help

Your new HP Pavilion computer is built to work right now — and for many years to come. But it is a complex, powerful machine, and sometimes things go wrong. If that happens to your computer, Hewlett-Packard is ready to help.

Getting Started

Follow the setup poster and the *Quick Start Guide* for help with setting up and using your PC.

Register Your PC

It is always best to register your PC. This allows for quicker help when you need it. You can register your PC by the electronic registration program that automatically starts when you first turn on your PC. Or, you can register on the Web at <http://register.hp.com>.

See What You Can Do

There's lots of helpful information included with your HP Pavilion. First look at Help on your Windows® desktop (to access it, click **Start** on the taskbar). It contains more detailed help and will give you suggestions on how to fix the problem.

Within the Help and Support Center, you can get the latest news from HP about your PC. Be sure to also check the updates from HP that are sent to your desktop from time to time.

Next, try a little surfing! The HP Web site has updated software, tips and tricks, answers for common problems, and other information. Go to <http://www.hp.com/cposupport> and search for your HP Pavilion model.

Call HP Customer Care Center

Finally, if these steps don't help, you can reach a real, knowledgeable person by calling the HP Customer Care Center in your area. Phone assistance to get you up and running is free for 30 days from the time you purchased your computer. After 30 days, there may be a charge, but the helpful support is still available.

And, if Necessary: Get Repair

If your computer needs to be repaired or to have parts replaced, you have two choices.

- 1 You can easily replace many of your HP Pavilion parts that are considered consumer replaceable. This is the fastest method of repair, as many times we can send the part directly to your home or business in a few days. This service is free for one year from the date you purchased your computer.
- 2 If a repair is necessary, the HP Customer Care Center will make arrangements to fix your computer. This service is free for one year from the date you purchased your computer.

There are a few limitations and exclusions to this warranty (as well as some important details), which are described in the following section.

The Legal Language

Hewlett-Packard Limited Warranty Statement

HP PRODUCT DURATION OF LIMITED WARRANTY

Hardware — Parts and Labor:	1 Year
Phone assistance to get you up-and-running:	30 days

HP warrants to you, the end-user customer, that HP hardware, accessories, and supplies will be free from defects in materials and workmanship after the date of purchase, for the period specified above. If HP receives notice of such defects during the warranty period, HP will, at its option, either repair or replace products which prove to be defective. Replacement products may be either new or equivalent in performance to new.

HP warrants to you that HP software will not fail to execute its programming instructions after the date of purchase, for the period specified above, due to defects in material and workmanship when properly installed and used. If HP receives notice of such defects during the warranty period, HP will replace software which does not execute its programming instructions due to such defects.

HP does not warrant that the operation of HP products will be uninterrupted or error free. If HP is unable, within a reasonable time, to repair or replace any product to a condition as warranted, you will be entitled to a refund of the purchase price on a prorated basis upon prompt return of the product.

HP products may contain remanufactured parts equivalent to new in performance or may have been subject to incidental use.

Warranty does not apply to defects resulting from (a) improper or inadequate maintenance or calibration, (b) software, interfacing, parts, or supplies not supplied by HP, (c) unauthorized modification or misuse, (d) computer viruses of any origin, (e) operation outside of the published environmental specifications for the product, (f) improper site preparation or maintenance, or (g) unplanned acts of nature, such as floods, tornadoes, lightning strikes, hurricanes, or earthquakes. TO THE EXTENT ALLOWED BY LOCAL LAW, THE ABOVE WARRANTIES ARE EXCLUSIVE AND NO OTHER WARRANTY OR CONDITION, WHETHER WRITTEN OR ORAL, IS EXPRESSED OR IMPLIED AND HP SPECIFICALLY DISCLAIMS ANY IMPLIED WARRANTIES OR CONDITIONS OF MERCHANTABILITY, SATISFACTORY QUALITY, AND FITNESS FOR A PARTICULAR PURPOSE. Some countries/regions, states, or provinces do not allow limitations on the duration of an implied warranty, so the above limitation or exclusion might not apply to you. This warranty gives you specific legal rights and you might also have other rights that vary from country/region to country/region, state to state, or province to province.

HP's limited warranty is valid in any country/region or locality where HP has a support presence for this product and where HP has marketed this product. The level of warranty service you receive may vary according to local standards. HP will not alter form, fit, or function of the product to make it operate in a country/region for which it was never intended to function for legal or regulatory reasons.

TO THE EXTENT ALLOWED BY LOCAL LAW, THE REMEDIES IN THIS WARRANTY STATEMENT ARE YOUR SOLE AND EXCLUSIVE REMEDIES. EXCEPT AS INDICATED ABOVE, IN NO EVENT WILL HP OR ITS SUPPLIERS BE LIABLE FOR LOSS OF DATA OR FOR DIRECT, SPECIAL, INCIDENTAL, CONSEQUENTIAL (INCLUDING LOST PROFIT OR DATA), OR OTHER DAMAGE, WHETHER BASED IN CONTRACT, TORT, OR OTHERWISE. Some countries/regions, states, or provinces do not allow the exclusion or limitation of incidental or consequential damages, so the above limitation or exclusion may not apply to you.

THE WARRANTY TERMS CONTAINED IN THIS STATEMENT, EXCEPT TO THE EXTENT LAWFULLY PERMITTED, DO NOT EXCLUDE, RESTRICT, OR MODIFY AND ARE IN ADDITION TO THE MANDATORY STATUTORY RIGHTS APPLICABLE TO THE SALE OF THIS PRODUCT TO YOU.

Network Interface Cards

HP warrants the operation on a network interface card (NIC), only if factory preinstalled by HP, as follows: HP will make sure the correct drivers are installed; HP will make sure that the HP Pavilion recognizes the NIC. NO CONNECTIVITY ISSUES ARE SUPPORTED.

DVD Region Codes

DVD players utilize country/region codes to limit playing DVDs designed for that country/region. You may change the country/region setting of a DVD player only five times. After changing this setting five times, the setting becomes permanent and cannot be changed.

Software Media (CDs)

The software CDs that come with your system are warranted to be free from defects for one year. Any claims for missing CDs need to be made within 30 days. Any claims for defective CDs may require the exchange of the CDs.

Customer Responsibilities

You may be required to run HP-supplied diagnostic programs before an in-home visit will be scheduled or a replacement part will be dispatched.

You are responsible for the security of your proprietary and confidential information and for maintaining a procedure external to the products for reconstruction of lost or altered files, data, or programs. You should back up all data on your system before calling the HP Customer Care Center.

For In-home service, you must provide: Access to the product; adequate working space and facilities within a reasonable distance of the product; access to and use of all information and

facilities determined necessary by HP to service the product; and operating supplies and consumables such as you would use during normal operation.

When service is being performed in-home, you or your representative, 18 years of age or older, must be present at all times. You must state if the product is being used in an environment which poses a potential health hazard to repair personnel; HP may require that the product be maintained by customer personnel under direct HP supervision. HP may also refuse to provide In-home service in special circumstances and will provide an alternative repair method such as Carry-in repair.

Obtaining Hardware Warranty Repair Service

For the duration of the one-year parts and labor warranty, repair service includes Consumer-replaceable Parts services, Carry-in services, and In-home services as described below. To obtain hardware warranty service, call the HP Customer Care Center. You must be prepared to supply the proof-of-purchase date.

The time it takes to repair your computer will vary based upon location and circumstances. The phone agent can supply more details.

Consumer-Replaceable Parts Services

Consumer-replaceable components — such as the keyboard, mouse, speakers, and monitor — may be serviced through expedited part shipment. In this event, HP will send you the component and, if necessary, telephone assistance on replacement of the component. In some cases, HP will ask for a credit card as collateral for the part (such as monitors) and will charge you for the retail price of the part if the failed product is not returned within 30 days.

Carry-In Services

Hardware service during the one-year warranty period is provided by bringing or mailing your PC to an HP Pavilion authorized service provider. The HP Customer Care Center can provide you with details on the location nearest you.

In-Home Services

In-home service in Australia and New Zealand is available with certain products only, and is unavailable in certain locations. The HP Customer Care Center can give you more information.

HP Software Product License Agreement

ATTENTION: USE OF THE SOFTWARE IS SUBJECT TO THE HP SOFTWARE LICENSE TERMS SET FORTH BELOW; USING THE SOFTWARE INDICATES YOUR ACCEPTANCE OF THESE LICENSE TERMS. IF YOU DO NOT ACCEPT THESE LICENSE TERMS, YOU MAY RETURN THE SOFTWARE FOR A FULL REFUND. IF THE SOFTWARE IS BUNDLED WITH ANOTHER PRODUCT, YOU MAY RETURN THE ENTIRE UNUSED PRODUCT FOR A FULL REFUND.

The HP Software Product License Agreement will govern all Software which is provided to you with the exception of Microsoft® Software. Microsoft Products are licensed to you under the Microsoft End User License Agreement (EULA) contained in the Microsoft documentation online.

The following License Terms govern your use of the accompanying Software unless you have a separate signed agreement with HP.

License

GRANT — HP grants you a license to use one copy of the Software. “Use” means storing, loading, installing, executing, or displaying the Software. You may not modify the Software or disable any licensing or control features of the Software. If the Software is licensed for “concurrent use,” you may not allow more than the maximum number of authorized users to Use the Software concurrently.

OWNERSHIP — The Software is owned and copyrighted by HP, its subsidiaries, or its third-party suppliers. Your license confers no title to, or ownership in, the Software and is not a sale of any rights in the Software. HP’s third-party suppliers may protect their rights in the event of any violation of these License Terms.

Copies

ADAPTATIONS — You may only make copies or adaptations of the Software for archival purposes or when copying or adaptation is an essential step in the authorized Use of the Software. You must reproduce all copyright notices in the original Software on all copies or adaptations. You may not copy the Software onto any public network.

If your computer was shipped with a Recovery CD, (i) the Recovery CD and/or Support Utility software may be used only for restoring the hard disk of the HP computer system with which the Recovery CD originally was provided, and (ii) if separate EULA(s) are included with your computer for any other Microsoft products which are included on the Recovery CD, those Microsoft products are subject to the terms of their respective EULA(s).

No Disassembly

DECRYPTION — You may not disassemble or decompile the Software unless HP’s prior written consent is obtained. In some jurisdictions, HP’s consent may not be required for limited disassembly or decompilation. Upon request, you will provide HP with reasonably detailed information regarding any disassembly or decompilation. You may not decrypt the Software unless decryption is a necessary part of the operation of the Software.

TRANSFER — Your license will automatically terminate upon any transfer of the Software. Upon transfer, you must deliver the Software, including any copies and related documentation, to the transferee. The transferee must accept these License Terms as a condition to the transfer.

TERMINATION — HP may terminate your license upon notice for failure to comply with any of these License Terms. Upon termination, you must immediately destroy the Software, together with all copies, adaptations, and merged portions in any form.

EXPORT REQUIREMENTS — You may not export or re-export the Software or any copy or adaptation in violation of any applicable laws or regulations.

(REV. 090502)

Declaration of Conformity

According to ISO/IEC Guide 22 and EN 45014

Manufacturer's Name: Hewlett-Packard Company
Manufacturer's Address: 10500 Ridgeview Ct.
Cupertino, CA 95015-4010
USA

declares that the product

Product Name: HP Pavilion Multimedia Personal Computer System
Model Number(s): 100 series, 300 series, 400 series, 500 series, 600 series, 700 series, a000 series, t000 series, m000 series
Product Options: All

conforms to the following Product Specifications:

Safety: IEC 60950:1991 + A1, A2, A3, A4
EN 60950:1992 + A1, A2, A3, A4, A11
IEC 60825-1:1993 + A1/E 60825-1:1994 + A11 Class 1 (Laser/LED)

EMC: CISPR 22:1997/EN 55022:1998 Class B¹⁾
CISPR 24:1997/EN 55024:1998
IEC 61000-3-2:1995/EN61000-3-2:1995 + A14 — Harmonics
IEC 61000-3-3:1994/EN61000-3-3:1995 — Flicker
FCC Title 47 CFR, Part 15 Class B²⁾/ICES-003, Issue 2
AS/NZS 3548:1995 + A1 + A2:1997/CISPR 22:1993 + A1 + A2:1996
Class B¹⁾

Telecom: TBR 21:1998, EG201 121:1998

Supplementary Information:

The product herewith complies with the requirements of the following Directives and carries the CE marking accordingly.

— the R&TTE Directive 1999/5/EC

- 1) The Product was tested in a typical configuration with Hewlett-Packard Personal Computer and peripherals.
- 2) This Device complies with Part 15 of the FCC Rules. Operation is subject to the following two conditions: (1) this device may not cause harmful interference, and (2) this device must accept any interference received, including interference that may cause undesired operation.

Hardware Quality Engineering Manager
Cupertino, CA, USA May, 2003

For Regulatory Compliance Information ONLY, contact:

Australian Contact: Product Regulations Manager
Hewlett-Packard Australia Ltd.
31-41 Joseph Street
Blackburn, Victoria 3130, Australia

Operating Specifications

Electrical ratings:	Models: 100 series, 300 series, 400 series, 500 series, 600 series, 700 series, a000 series, t000 series, and m000 series 100–127 V _~ /200–240 V _~ , 4/2 A, 50/60 Hz
Operating temperature:	5° to 35° C (On models with DVD+RW/+R drives, the operating temperature is 5° to 30° C)
Storage temperature:	-40° to 70° C
Operating humidity:	15 to 80% @ 26° C
Storage humidity:	90% @ 65° C (non-condensing)
Operating altitude:	0–2286 m
Storage altitude:	0–4572 m

Batteries are delivered with this product. When empty, do not throw them away but collect as small chemical waste.

Regulatory and Safety Information



Warning: *The HP Pavilion is heavy; be sure to use ergonomically correct lifting procedures when moving the computer.*



Warning: *Electrostatic discharge (ESD) can damage disk drives, add-in cards, and other components. If an ESD station is not available, wear a wrist strap attached to a metal part of the computer. Place cards on a conductive foam pad or inside the conductive wrapper they came in; do not place the cards on top of the wrapper.*



Warning: *Do not operate the system with the cover removed. Always replace the cover before turning on the system.*



Warning: *Please read the "Additional Safety Information" located later in this document before installing and connecting your system to the electrical power system.*



Warning: *Using the wrong type of memory module could damage the system.*



Warning: *Do not pull the memory module out of the socket. Use the retaining clips to eject the module.*



Warning: *Do not overload the system by installing add-in cards that draw excessive current. The system is designed to provide 2 amps (average) of +5 V power for each board/card in the computer. The total +5 V current draw in a fully loaded system (one with all add-in card slots filled) must not exceed the total number of slots multiplied by 2 amps.*



Warning: *Be careful of the sharp edges on the expansion slot cover.*



Warning: *There is danger of an explosion if the battery is incorrectly replaced. Replace only with the same, or equivalent, type of battery. Discard used batteries according to the manufacturer's instructions.*

ENERGY STAR Compliance

Hewlett-Packard Pavilion PCs and Monitors marked with the ENERGY STAR® logo on the packaging box qualify with the U.S. Environmental Protection Agency's ENERGY STAR guidelines for energy efficiency.



Products with the ENERGY STAR label are designed to use less energy, help you save money on utility bills, and help protect the environment.

ENERGY STAR® is a registered trademark owned by the U.S. government.

Australia Telecom Statement

The computer must be connected to the Telecommunication Network through a line cord that meets the requirements of ACA Technical Standard TS008.



Warning: Modems without integral RJ-11 that are shipped with this computer must be installed only in devices displaying the A-tick.

New Zealand Telecom Statement

The grant of a Telepermit for any item of terminal equipment indicates only that Telecom has accepted that the item complies with minimum conditions for connection to its network. It indicates no endorsement of the product by Telecom, nor does it provide any sort of warranty. Above all, it provides no assurance that any item will work correctly in all respects with another item of Telepermitted equipment of a different make or model, nor does it imply that any product is compatible with all of Telecom's network services.

Some parameters required for compliance with Telecom's Telepermit requirements are dependent on the equipment (PC) associated with this modem. The associated equipment shall be set to operate within the following limits for compliance with Telecom's specification:

- **For automatically initiated calls to the same number:**
 - (a) There shall be no more than 10 call attempts to the same number within any 30-minute period for a single manual call initiation.
 - and
 - (b) The equipment shall be on the hook for a period of not less than 30 seconds between the end of one attempt and the beginning of the next attempt.
- **For automatically initiated calls to different numbers:** The equipment shall be on-hook for a period of not less than 5 seconds between the end of one attempt and the beginning of the next attempt.
- **For automatically answered incoming calls:** Incoming calls shall be answered between 3 and 30 seconds of the first ring.

For correct operation of the ringers in each device, the total of the RNs (ringer number) of all devices connected to a single line at any time should not exceed 5. The RN can be found printed on the Telepermit Label.



Warning: *When using this device, basic safety precautions should always be followed to reduce the risk of fire, electric shock, and injury to persons, including the following:*

- ***Do not use this product near water, for example, near a bathtub, wash bowl, kitchen sink or laundry tub, in a wet basement or near a swimming pool.***
- ***Avoid using this product during an electrical storm. There may be a remote risk of electric shock from lightning.***
- ***Do not use this product to report a gas leak in the vicinity of the leak.***
- ***Always disconnect the modem cable before opening the equipment enclosure or touching an uninsulated modem cable, jack or internal components.***
- ***If this product was not provided with a telephone line cord, use only No. 26 AWG or larger telecommunication line cord in order to reduce the risk of fire.***
- ***Do not plug a modem or telephone cable into the Network Interface Card (NIC) receptacle.***

SAVE THESE INSTRUCTIONS

Additional Safety Information

This product has not been evaluated for connection to an "IT" power system (an AC distribution system with no direct connection to earth, according to IEC 60950).

AC Power Safety Warning



Warning: *Install the computer near an AC outlet. The AC power cord is your HP Pavilion's main AC disconnecting device and must be easily accessible at all times. For your safety, the power cord provided with your system has a grounded plug. Always use the power cord with a properly grounded wall outlet, to avoid the risk of electrical shock.*





Warning: *Your system is provided with a voltage select switch for use in a 115 or 230 VAC power system. The voltage select switch has been pre-set to the correct voltage setting for use in the particular country/region where it was initially sold. Changing the voltage select switch to the incorrect position can damage your PC and void any implied warranty.*

 **Warning:** To reduce the possibility of an electric shock from the telephone network, plug your computer into the AC outlet before connecting it to the telephone line. Also, disconnect the telephone line before unplugging your computer from the AC power outlet.

 **Warning:** Always disconnect the modem cord from the telephone system before installing or removing your computer cover.

 **Warning:** Do not operate the computer with the cover removed.

 **Warning:** The power supply is not user-serviceable. To prevent damage to the power supply, have a qualified person repair or replace it. All other components are user-serviceable.

 **Warning:** Electrostatic discharge (ESD) can damage disk drives, add-in cards, and other components. If an ESD station is not available, wear a wrist strap attached to a metal part of the computer. Place cards on a conductive foam pad or inside the card wrapper, if possible, but never on the card wrapper.

 **Warning:** For your safety, always unplug the system from its power source and from any telecommunications systems (such as phone lines), networks, or modems before performing any of the procedures described in this guide. Failure to do so may result in personal injury or equipment damage. Hazardous voltage levels are inside the power supply and modem of this product.

Lithium Battery Caution

 **Warning:** The PC uses a lithium battery, type CR2032. There is danger of an explosion if the battery is incorrectly replaced. Replace only with the same, or equivalent, type recommended by the manufacturer. Dispose of used batteries according to the manufacturer's instructions.

Laser Safety Statement

Class 1 LED Product

The CD-ROM and DVD-ROM drives contain a laser system and are classified as a "Class 1 Laser Product" under a U.S. Department of Health and Human Services (DHHS) Radiation Performance standard according to the Radiation Control for Health and Safety Act of 1968.

Should the unit ever require maintenance, contact an authorized service location.



Warning: Use of controls, adjustments, or performance procedures other than those specified in the Upgrading and Servicing the PC guide may result in hazardous radiation exposure. To prevent direct exposure to laser beam, do not try to open the enclosure of the CD-ROM or DVD-ROM.

Laser Product Label

The following label or equivalent is located on the surface of HP laser products:



This label indicates that the product is classified as a CLASS 1 LASER PRODUCT. This label appears on a laser device installed in your product.

TV Antenna Connectors Protection

External Television Antenna Grounding

If an outside antenna or cable system is connected to the product, be sure the antenna or cable system is electrically grounded so as to provide some protection against voltage surges and built-up static charges. Article 810 of the National Electrical Code, ANSI/NFPA 70, provides information with regard to proper electrical grounding of the mast and supporting structure, grounding of the lead-in wire to an antenna-discharge unit, size of grounding conductors, location of antenna-discharge unit, connection to grounding electrodes, and requirements for the grounding electrode.

Lightning Protection

For added protection of any Hewlett-Packard product during a lightning storm, or when it is left unattended and unused for long periods of time, unplug the product from the wall outlet and disconnect the antenna or cable system. This will prevent damage to the product from lightning and power line surges.

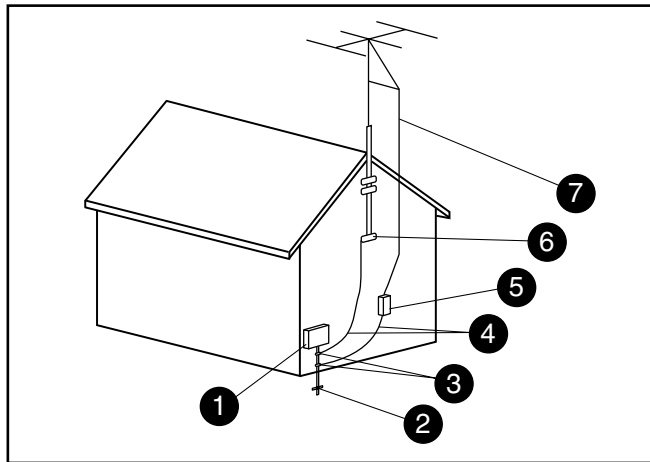

Antenna Grounding

Antenna Grounding

Reference	Grounding Component
①	Electric Service Equipment
②	Power Service Grounding Electrode System (NEC Art 250, Part H)
③	Ground Clamps
④	Grounding Conductors (NEC Section 810-21)
⑤	Antenna Discharge Unit (NEC Section 810-20)
⑥	Ground Clamp
⑦	Antenna Lead in Wire

Power Lines

An outside antenna system should not be located in the vicinity of overhead power lines or other electric light or power circuits, or where it can fall into such power lines or circuits.



Warning: When installing an outside antenna system, extreme care should be taken to keep from touching such power lines or circuits as contact with them could be fatal.

© 2003 Hewlett-Packard Company
© 2003 Hewlett-Packard Development Company, L.P.
All rights reserved.

