

# *HP LaserJet 8150, 8150 N, 8150 DN, 8150 HN, and 8150 MFP Printers*



Contents



How to  
navigate



Index



## *User Guide*



## Copyright and License

Copyright Hewlett-Packard Company 2001

All Rights Reserved. Except as allowed by copyright laws or herein, reproduction, adaptation, or translation without prior written permission is prohibited.

A user of the Hewlett-Packard printer associated with this user guide is granted a license to: a) print hard copies of this user guide for PERSONAL, INTERNAL or COMPANY use subject to the restriction not to sell, re-sell or otherwise distribute the hard copies; and b) place an electronic copy of this user guide on a network server provided access to the electronic copy is limited to PERSONAL, INTERNAL users of the Hewlett-Packard printer associated with this user guide.

The information contained in this document is subject to change without notice.

Edition 4, 4/2009

## Trademark Credits

**Acrobat is a trademark of Adobe Systems Incorporated.**

PostScript® is a trademark of Adobe Systems Incorporated which may be registered in certain jurisdictions.

Arial, Monotype, and Times New Roman are U.S. registered trademarks of the Monotype Corporation.

Helvetica, Palatino, Times, and Times Roman are trademarks of Linotype AG and/or its subsidiaries in the U.S. and other countries.

Microsoft, MS Windows, Windows, and Windows NT are U.S. registered trademarks of Microsoft Corporation.

TrueType is a U.S. trademark of Apple Computer, Inc.

ENERGY STAR is a U.S. registered service mark of the U.S. EPA.



## *HP Customer Care*

Thank you for your purchase. Along with your product, you receive a variety of support services from Hewlett-Packard and our support partners. These services are designed to give you the results you need, quickly and professionally.



### *Online Services:*

For 24-hour access to information over your modem, we suggest these services:

#### *World Wide Web*

Printer drivers, updated HP printer software, plus product and support information may be obtained from the following URLs:

in the U.S.  
in Europe

<http://www.hp.com>  
<http://www2.hp.com>

**Continued on next page.**



Printer drivers may be obtained from the following sites:

in China	<a href="http://www.hp.com.cn">http://www.hp.com.cn</a>
in Japan	<a href="http://www.jpn.hp.com">http://www.jpn.hp.com</a>
in Korea	<a href="http://www.hp.co.kr">http://www.hp.co.kr</a>
in Taiwan	<a href="http://www.hp.com.tw">http://www.hp.com.tw</a>
or the local driver website	<a href="http://www.dds.com.tw">http://www.dds.com.tw</a>



## ***Obtaining software utilities and electronic information:***



### ***For U.S. and Canada:***

**Phone:**

(661) 257-5565

**Fax:**

(661) 257-6995

**Mail:**

HP Distribution  
P.O. Box 907  
Santa Clarita, CA  
91380-9007  
U.S.A



### ***For Asia-Pacific countries/regions:***

Contact Mentor Media at (65) 740-4477 (Hong Kong SAR, Indonesia, Philippines, Malaysia, or Singapore). For Korea, call (82) (2) 3270-0805 or (82) (2) 3270-0893.



***For Australia, New Zealand, and India:***

For Australia, call (61) (3) 8877-8000. For New Zealand, call (64) (9) 356-6640. For India, call (91) (11) 682-6035.

***For European English:***

Call +44 (0) 1429 865 511.

***HP direct ordering for accessories or supplies:***

Call 1-800-538-8787 (U.S.) or 1-800-387-3154 (Canada).

***HP Support Assistant compact disc:***

This support tool offers a comprehensive online information system designed to provide technical and product information on HP products. To subscribe to this quarterly service in the U.S. or Canada, call 1-800-457-1762. In Hong Kong SAR, Indonesia, Malaysia, or Singapore, call Fulfill Plus at (65) 740-4477.



## ***HP Service Information:***

To locate HP-Authorized Dealers, call 1-800-243-9816 (U.S.) or 1-800-387-3867 (Canada).



## ***HP Service Agreements:***

Call 1 (800) 743-8305 (U.S.) or (800) 268-1221 (Canada). For extended service, call 1-800-446-0522.



## *Customer support options worldwide*

### ***Customer Support and Product Repair Assistance for the U.S. and Canada***

Call (208) 323-2551 Monday through Friday from 6 am to 6 pm, (Mountain Time) free of charge during the warranty period. However, your standard long-distance phone charges still apply. Have your system nearby and your serial number ready when calling.

If you know your printer needs repair, call 1-800-243-9816 to locate your nearest HP-Authorized service provider, or call (208) 323-2551 for HP centralized service dispatch.

Post-warranty telephone assistance is available to answer your product questions. Call (900) 555-1500 (\$2.50\* per minute, U.S. only) or call 1-800-999-1148 (\$25\* per call, Visa or MasterCard, U.S. and Canada) Monday through Friday from 6 am to 6 pm (Mountain Time). *Charges begin only when you connect with a support technician. \*Prices subject to change.*





## ***European Customer Support Center Language and In-Country Options Available***

Open Monday through Friday 8:30–18:00 CET

HP provides a free telephone support service during the warranty period. By calling a telephone number listed below, you will be connected to a responsive team waiting to help you. If you require support after your warranty has expired, you can receive support for a fee through the same telephone number. The fee is charged on a per-incident basis. When calling HP, have the following information ready: product name and serial number, date of purchase, and description of the problem.

English	Ireland: (353) (1) 662-5525 U.K.: (44) (171) 512-5202 International: (44) (171) 512-5202
Dutch	Belgium: (32) (2) 626-8806 Netherlands: (31) (20) 606-8751
French	France: (33) (01) 43-62-3434 Belgium: (32) (2) 626-8807 Switzerland: (41) (84) 880-1111
German	Germany: (49) (180) 525-8143 Austria: (43) (1) 0660-6386
Norwegian	Norway: (47) 2211-6299
Danish	Denmark: (45) 3929-4099

**Continued on next page.**



Finnish	Finland: (358) (9) 0203-47288
Swedish	Sweden: (46) (8) 619-2170
Italian	Italy: (39) (2) 264-10350
Spanish	Spain: (34) (90) 232-1123
Portuguese	Portugal: (351) (1) 441-7199



***In-country/region support numbers***

Argentina	787-8080
Australia	(61) (3) 272-8000
Brazil	022-829-6612
Canada	(208) 323-2551
Chile	800-360999
China	(86) (10) 65053888-5959
Czech Republic	(42) (2) 471-7321
Greece	(30) (1) 689-6411
Hong Kong SAR	(852) 800-96-7729
Hungary	(36) (1) 343-0310
India	(91) (11) 682-6035
	(91) (11) 682-6069

**Continued on next page.**



Indonesia	(62) (21) 350-3408
Korea	(82) (2) 3270-0700
Korea outside Seoul	(82) (080) 999-0700
Japan	(81) (3) 3335-8333
Malaysia	(60) (3) 295-2566
Mexico (Mexico City)	01 800-22147
Mexico (outside Mexico City)	01 800-90529
New Zealand	(64) (9) 356-6640
Philippines	(63) (2) 894-1451
Poland	(48) (22) 37-5065
Portugal	(351) (1) 301-7330
Russia	(7) (95) 923-5001
Singapore	(65) 272-5300
Taiwan	(886) (02) 717-0055
Thailand	+66 (0) 2 661-4011
Turkey	(90) (1) 224-5925



# Contents



## Introduction

<u>Navigation Features</u>	<u>19</u>
<u>Text Conventions</u>	<u>20</u>
<u>Additional Features of Acrobat Reader</u>	<u>21</u>
<u>Tips for Use</u>	<u>23</u>

## 1 Printer Basics

<u>Overview</u>	<u>24</u>
<u>Printer Features and Benefits</u>	<u>26</u>
<u>Printer Information</u>	<u>32</u>
<u>Configurations</u>	<u>32</u>
<u>Printer Parts and Locations</u>	<u>35</u>
<u>Accessories and Supplies</u>	<u>37</u>
<u>Suggested Accessories</u>	<u>38</u>
<u>Ordering Information</u>	<u>42</u>
<u>Control Panel Layout</u>	<u>53</u>
<u>Control Panel Lights</u>	<u>54</u>
<u>Configuration Page</u>	<u>55</u>
<u>Control Panel Keys</u>	<u>56</u>
<u>Control Panel Menus</u>	<u>58</u>
<u>Paper Handling LED Status Interpretation</u>	<u>60</u>

<u>Printer Software</u>	<u>62</u>
<u>Printer Drivers</u>	<u>66</u>
<u>Software for Windows</u>	<u>71</u>
<u>Installing Windows Printing Software (CD)</u>	<u>72</u>
<u>Installing Macintosh Printing Software</u>	<u>74</u>
<u>Software for Macintosh Computers</u>	<u>80</u>
<u>Software for Networks</u>	<u>83</u>

## 2 Printing Tasks

<u>Overview</u>	<u>88</u>
<u>Loading the Input Tray</u>	<u>89</u>
<u>Loading Tray 1</u>	<u>89</u>
<u>Loading Trays 2, 3, and the Optional 2 x 500-sheet Input Tray (Trays 4 and 5)</u>	<u>93</u>
<u>Loading the Optional 2000-sheet Input Tray (Tray 4)</u>	<u>98</u>
<u>Selecting the Output Bin</u>	<u>101</u>
<u>Printing to the Standard Output Bin</u>	<u>103</u>
<u>Printing to the Face-up Bin</u>	<u>105</u>
<u>Printing to a Mailbox</u>	<u>106</u>



<a href="#">Using the Stapler</a>	113
<a href="#">Loading Staple Cartridges (5-bin Mailbox with Stapler)</a>	113
<a href="#">Stapling Documents (5-bin Mailbox with Stapler)</a>	114
<a href="#">Printing Both Sides of Paper (Optional Duplex Printing Accessory)</a>	117
<a href="#">Printing Envelopes</a>	123
<a href="#">Feeding Envelopes Automatically (Optional Envelope Feeder)</a>	123
<a href="#">Inserting the Envelope Feeder</a>	125
<a href="#">Loading Envelopes into the Envelope Feeder</a>	126
<a href="#">Changing Fuser Levers for Printing Envelopes</a>	128
<a href="#">Printing Envelopes from Tray 1</a>	130
<a href="#">Loading Envelopes in Tray 1</a>	132
<a href="#">Printing Envelopes from Your Software Application</a>	133
<a href="#">Printing Special Paper</a>	134
<a href="#">Printing Letterhead, Preprinted Paper, or Prepunched Paper</a>	134
<a href="#">Printing Labels</a>	135
<a href="#">Printing Transparencies</a>	137
<a href="#">Custom-size Paper in Tray 1</a>	139
<a href="#">Printing Cards, Custom-size, and Heavy Paper</a>	141

### **[3 Advanced Printing Tasks](#)**

<a href="#">Overview</a>	144
<a href="#">Using Features in the Printer Driver</a>	146
<a href="#">Different First Page</a>	149
<a href="#">Blank Back Page</a>	151
<a href="#">Printing Multiple Pages on One Sheet of Paper</a>	152
<a href="#">Customizing Tray 1 Operation</a>	154
<a href="#">Tray 1 Mode=First</a>	154
<a href="#">Tray 1 Mode=Cassette</a>	155
<a href="#">Manually Feeding Paper from Tray 1</a>	156
<a href="#">Printing by Type and Size of Paper</a>	157
<a href="#">Benefits of Printing by Type and Size of Paper</a>	157
<a href="#">Changing the Variable Fuser Mode</a>	160
<a href="#">Loading Custom-size Paper</a>	163
<a href="#">Job Retention</a>	166
<a href="#">Quick Copying a Job</a>	167
<a href="#">Proofing and Holding a Job</a>	170
<a href="#">Printing a Private Job</a>	173
<a href="#">Storing a Print Job</a>	176



<a href="#">Printing with the Optional HP Fast InfraRed Connect</a>	179
<a href="#">Setting Up to Print with Windows 3.1x</a>	180
<a href="#">Setting Up to Print with Windows 9x</a>	181
<a href="#">Printing a Job</a>	182
<a href="#">Interrupting and Resuming Printing</a>	184
<a href="#">Edge-to-Edge Printing</a>	185
<a href="#">Duplex Registration</a>	187

#### **4 Printer Maintenance**

<a href="#">Overview</a>	189
<a href="#">Printer Maintenance Kit</a>	190
<a href="#">Managing the Toner Cartridge</a>	191
<a href="#">HP Policy on Non-HP Toner Cartridges</a>	191
<a href="#">Toner Cartridge Storage</a>	191
<a href="#">Toner Cartridge Life Expectancy</a>	192
<a href="#">Checking the Toner Level</a>	192
<a href="#">Resetting the HP TonerGauge</a>	193
<a href="#">Continue Printing When Toner is Low</a>	194
<a href="#">Cleaning the Printer</a>	197

#### **5 Problem Solving**

<a href="#">Overview</a>	200
<a href="#">Clearing Paper Jams</a>	202
<a href="#">Clearing Jams from the Input Tray Areas</a>	204
<a href="#">Clearing Jams from the Optional Duplex Printing Accessory</a>	213
<a href="#">Clearing Jams from the Top Cover Area</a>	215
<a href="#">Clearing Jams from the Output Areas</a>	217
<a href="#">Clearing Jams from an Optional HP Output Device</a>	221
<a href="#">Clearing Jams from the Stapler (5-bin Mailbox with Stapler)</a>	222
<a href="#">Solving Repeated Paper Jams</a>	224
<a href="#">Understanding Printer Messages</a>	226
<a href="#">Using the Printer Online Help System</a>	227
<a href="#">Correcting Output Quality Problems</a>	254
<a href="#">Correcting Wrinkles on Envelopes</a>	260
<a href="#">Determining Printer Problems</a>	262
<a href="#">Printer Problems</a>	264
<a href="#">Software, Computer, and Printer Interface Problems</a>	267
<a href="#">Cabling Configurations</a>	292
<a href="#">Selecting an alternate PPD</a>	308





[Communicating with an Optional HP JetDirect EIO Print Server . . .](#) 310

[Checking the Printer’s Configuration](#) 313

[Configuration Page . . . . .](#) 314

[Menu Map . . . . .](#) 317

[PCL or PS Font List . . . . .](#) 318

[File Directory Page . . . . .](#) 320

[Event Log Page . . . . .](#) 321

[Paper Path Test . . . . .](#) 323

**6 HP Digital Copy**

[Overview . . . . .](#) 324

[HP Digital Copy Installation . . . . .](#) 325

[Installation Checklist . . . . .](#) 325

[Step 1. Locate HP Digital Copy Parts . . . . .](#) 326

[Step 2. Prepare Printer and HP Digital Copy Location . . . . .](#) 327

[Step 3. Install the HP Digital Copy](#) 332

[Step 4. Test HP Digital Copy Operation . . . . .](#) 343

[Troubleshoot the HP Digital Copy.](#) 345

[HP Digital Copy Operating Instructions . . . . .](#) 346

[HP Digital Copy Features and Benefits . . . . .](#) 346

[HP Digital Copy Control Panel . . .](#) 347

[HP Digital Copy Settings . . . . .](#) 362

[Loading documents into the Automatic Document Feeder . . . . .](#) 364

[Loading documents onto the Flatbed . . . . .](#) 366

[Loading documents larger than the Document Board . . . . .](#) 367

[Reading a page from a thick book](#) 368

[Foreign Interface Harness . . . . .](#) 369

[Paper Specifications . . . . .](#) 370

[Document Quality . . . . .](#) 371

[HP Digital Copy Maintenance . . . . .](#) 373

[Clean the Document Cover, the Document Holder, and the Flatbed Glass . . . . .](#) 373

[Cleaning the Automatic Document Feeder . . . . .](#) 374

[Pad and Roller Maintenance . . . .](#) 376

[HP Digital Copy Problem Solving . . .](#) 377

[Temporary Error . . . . .](#) 378

[Equipment Error . . . . .](#) 379

**7 Service and Support**

[Overview . . . . .](#) 380

[Hewlett-Packard limited warranty statement . . . . .](#) 381



[Service During and After the Warranty Period](#) . . . . . 384

[Limited Warranty for Toner Cartridge Life](#) . . . . . 385

[HP Software License Terms](#) . . . . . 386

**[A Specifications](#)**

[Overview](#) . . . . . 389

[Paper Specifications](#) . . . . . 390

[Supported Sizes of Paper for Input and Output](#) . . . . . 392

[Supported Types of Paper](#) . . . . . 397

[Labels](#) . . . . . 403

[Transparencies](#) . . . . . 405

[Envelopes](#) . . . . . 406

[Card Stock and Heavy Paper](#) . . . . . 410

[Printer Specifications](#) . . . . . 412

[Physical Dimensions](#) . . . . . 412

[Environmental Specifications](#) . . . . . 417

**[B Control Panel Menus](#)**

[Overview](#) . . . . . 420

[Private/Stored Jobs Menu](#) . . . . . 423

[Information Menu](#) . . . . . 424

[Paper Handling Menu](#) . . . . . 427

[Print Quality Menu](#) . . . . . 435

[Printing Menu](#) . . . . . 439

[Configuration Menu](#) . . . . . 445

[Configuration of MBM Menu](#) . . . . . 456

[I/O Menu](#) . . . . . 457

[EIO Menu](#) . . . . . 460

[Duplex Registration Menu](#) . . . . . 464

[Resets Menu](#) . . . . . 465

**[C Printer Memory and Expansion](#)**

[Overview](#) . . . . . 467

[Determining Memory Requirements](#) . 470

[Installing Memory](#) . . . . . 471

[Checking Memory Installation](#) . . . . . 475

[Adjusting Memory Settings](#) . . . . . 476

[Installing EIO Cards/Mass Storage](#) . . 479

**[D Printer Commands](#)**

[Overview](#) . . . . . 480

[Understanding PCL Printer Command Syntax](#) . . . . . 483

[Combining Escape Sequences](#) . . . 484

[Selecting PCL Fonts](#) . . . . . 485

[Common PCL Printer Commands](#) . . . 486

**[E Regulatory Information](#)**

[Overview](#) . . . . . 494

[FCC Regulations](#) . . . . . 495



- [Environmental Product Stewardship . 497](#)
  - [Protecting the Environment . . . . . 497](#)
- [Material Safety Data Sheet . . . . . 502](#)
- [Environmental Conformity . . . . . 503](#)
- [Declaration of Conformity . . . . . 504](#)
- [Safety Statements . . . . . 508](#)
  - [Laser Safety Statement . . . . . 508](#)
  - [Canadian DOC Regulations . . . . . 509](#)
  - [VCCI Statement \(Japan\) . . . . . 510](#)
  - [Korean EMI statement . . . . . 511](#)
  - [Laser Statement for Finland . . . . . 512](#)



# *Introduction*

This section explains some of the features of this online user guide as well as tips and tricks to help you use it to its greatest potential. It provides an overview of the following information:





- [Navigation Features](#)
- [Text Conventions](#)
- [Additional Features of Acrobat Reader](#)
- [Tips for Use](#)

Additional features can be accessed through your Acrobat Reader menus and toolbars.



# Navigation Features



Button	Button Name	Function
	<b>Page Up and Down Arrows</b>	The Page Up and Down arrows allow you to scroll page-by-page through the online user guide. The Page Up arrow allows you to go back one page, while the Page Down arrow allows you to move forward one page.
	<b>Table of Contents Icon</b>	This Table of Contents Icon calls up the table of contents for the online user guide.
	<b>Introduction Icon</b>	The Introduction Icon calls up this introduction to the guide.
	<b>Index Icon</b>	The Index Icon calls up the online user guide text index. The index entries are linked to their related topics.



## Text Conventions

Some text is formatted differently to indicate specific meanings or functions. Below is a table that defines the different text formats and what they indicate.



---

Text Format Style	Meaning or Function
KEY CAP	This format is used to represent buttons on the printer, as well as keys on the computer keyboard.
<u>Hypertext</u>	This format is used to indicate that the text is linked to another page of the document. Clicking on the underlined text takes you to that page. Sometimes, a page number and section heading are included in the blue underlined text, but any text formatted this way indicates the presence of a link.
DISPLAY PANEL	This format is used to indicate text that is displayed on the control panel.
Input	This format indicates that the text is typed by the user at a command prompt or into a dialog box.

---







## Additional Features of Acrobat Reader

In addition to the navigation buttons provided on the right side of the page, Adobe Acrobat Reader has a number of other features that you may find useful.







---

Button	Button Name	Function
	<b>Actual Size</b>	This button sets the document view to the page's actual size.
	<b>Fit Page</b>	This button changes the document view so the page fits in the window.
	<b>Fit Visible Width</b>	This button changes the document view so the visible content and page width fit in the window.
	<b>Page Only</b>	This button displays the page only with no bookmarks or thumbnails.
	<b>Page With Bookmarks</b>	This button displays the page and bookmarks to the different sections of the document in a window to the left of the screen.



---

Button	Button Name	Function
	<b>Page With Thumbnails</b>	This button displays the page and small images of each page in a window to the left of the screen.
	<b>Back</b>	This button allows you to go to the previous link or to undo your last change.
	<b>Find</b>	This button calls up the Find dialog.
	<b>Zoom</b>	This button allows you to change the page size.

---



## *Tips for Use*

Use bookmarks to navigate between chapters.



When reading large amounts of text, turn off bookmarks and change the page view to full screen.



Use the find function under the Tools menu to find specific terms.

Use the back button (page [22](#)) in Adobe Acrobat Reader to return to the previous page when jumping from link to link.



**To print this document** - For best quality and quickest printing, always print using a compatible PostScript Level 3 emulation printer driver.

Due to the size of these print files, it is recommended that you print portions of this document rather than printing the whole document at one time.

To save paper when you are printing this online user guide, you can create a quick set to print 2 pages of the online user guide (N-up printing) on both sides of the paper (duplex printing). See the printer driver help for details on these features.



# 1 *Printer Basics*



## *Overview*

Congratulations on your purchase of an HP LaserJet printer. If you have not done so, see the getting started guide provided with the printer for setup instructions.

For detailed information on the HP Digital Copy (that comes with the HP LaserJet 8150 MFP), see the section on page [324](#) or the getting started guide provided with the HP Digital Copy.

Now that the printer is set up and ready to use, take a few moments to get to know the printer. This chapter introduces the following:

- [Printer Features and Benefits](#)
- [Printer Information](#)
- [Accessories and Supplies](#)

**Continued on next page.**





- [Control Panel Layout](#)
- [Paper Handling LED Status Interpretation](#)
- [Printer Software](#)



## *Printer Features and Benefits*



### *Speed and Throughput*

- Transmit Once, RIP ONCE technology
- 32 pages per minute (ppm) on Letter or ISO A4 paper
- Duty Cycle: 150,000 pages per month on Letter or ISO A4 paper
- 250 MHz microprocessor



### *Resolution*

- 600 dots per inch (dpi) with Resolution Enhancement technology (REt)
- FastRes 1200 provides 1200 dpi quality at full speed
- More than 220 levels of gray



## ***Memory***

- 32 MB (8150/8150 N/8150 DN/8150 HN) of RAM, expandable (up to 160 MB) using industry standard 100-pin DIMMs (Dual In-Line Memory Modules)
- 64 MB (8150 MFP) of RAM, expandable (up to 160 MB) using industry standard 100-pin DIMMs (Dual In-Line Memory Modules)
- Memory Enhancement technology (MEt) automatically compresses data to use RAM more efficiently
- 3.2 Gigabyte hard disk (8150 MFP)



## ***Enhanced Productivity (8150 MFP)***

- Fast, convenient walk up digital copying
- Advanced paper handling including electronic collation, dual scan heads, and automatic stapling
- Digital Sender module that easily converts and sends paper documents to email



## *Language and Fonts*

- HP PCL 6
- HP PCL 5e for compatibility
- Printer Job Language (PJL)
- Printer Management Language (PML)
- 45 scalable TrueType typefaces
- PostScript Level 3 Emulation standard



## *Paper Handling Options*

- **Input**
  - ◆ **Tray 1:** A multipurpose tray for paper, transparencies, labels, and envelopes. Holds up to 100 sheets of paper.
  - ◆ **Trays 2 and 3:** Two 500-sheet trays. These trays automatically sense paper sizes.
  - ◆ **Optional 2 x 500-sheet Input Tray (Trays 4 and 5):** Two 500-sheet trays. These trays automatically sense paper sizes.
  - ◆ **Optional 2000-sheet Input Tray (Tray 4):** One 2000-sheet tray. This tray automatically senses paper sizes.

**Continued on next page.**



- ◆ **Optional Duplex Printing Accessory:** Provides two-sided printing (both sides of paper).
- ◆ **Optional Envelope Feeder:** Automatically feeds up to 100 envelopes.
- ◆ **Optional Custom Paper Trays:** Allows printing on custom-size paper. Holds up to 500 sheets of paper. (Used in place of trays 3 or 5.)
- **Output**
  - ◆ **Standard Output Bin** (face-down bin): Holds up to 500 sheets of paper. Automatically senses when full.
  - ◆ **Face-up Bin:** Holds up to 100 sheets of paper. Provides the best results when printing transparencies, labels, and envelopes.
  - ◆ **Optional 5-bin Mailbox with Stapler:** Each of the 5 bins holds up to 250 sheets of paper. Provides job separation by stapling jobs.
  - ◆ **Optional 8-bin Mailbox:** Each of the 8 bins holds up to 250 sheets of paper.
  - ◆ **Optional 7-bin Tabletop Mailbox:** Each of the 7 bins holds up to 120 sheets of paper. Designed for tabletop printing.
  - ◆ **Optional 3000-sheet Stacker:** One 3000-sheet stacking device.
  - ◆ **Optional 3000-sheet Stapler/Stacker:** One 3000-sheet stacking device which provides multi-position stapling for up to 50 sheets of paper per document.

Continued on next page.



- **Input/Output**

- ◆ **HP Digital Copy:** The flatbed and the automatic document feeder have the ability to copy up to A3 or 11 x 17 size original documents. The automatic document feeder holds up to 50 sheets of paper.



### *Connectivity*

- 3 EIO (enhanced input/output) slots
- HP JetDirect EIO cards, Ethernet (10Base-T, 10Base2), Token Ring, Fast Ethernet 10/100Base-TX, USB, Serial, and Local Talk
- Parallel
- HP Fast InfraRed Connect (fast infrared connection)
- Foreign Interface Harness (HP LaserJet 8150 MFP or any model of HP LaserJet 8150 printer with an HP Digital Copy attached)



### *Environmental Features*

- EconoMode uses approximately 50% less toner, which extends the life of the toner cartridge (HP does not recommend full-time use of EconoMode)
- PowerSave setting saves energy (meets ENERGY STAR guidelines)
- High content of recyclable components and materials in the printer



## ***Firmware Updates***

Provides the ability to download firmware electronically.

To download the latest firmware, go to [http://www.hp.com/go/lj8150\\_firmware](http://www.hp.com/go/lj8150_firmware) and follow the instructions on the screen. To easily send firmware updates to multiple printers, use HP Web JetAdmin (go to <http://www.hp.com/go/webjetadmin>).



## Printer Information

### Configurations

#### *HP LaserJet 8150 printer*

The HP LaserJet 8150 printer (product number C4265A) comes standard with 32 MB RAM, wide format printing, two 500-sheet trays, and a 100-sheet multipurpose tray.

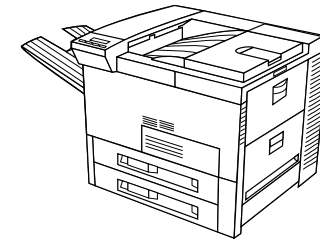

---

**Note**

The HP LaserJet 8150 requires an optional EIO card to connect to a Macintosh.

---

#### *HP LaserJet 8150 N printer*

The HP LaserJet 8150 N printer (product number C4266A) comes standard with 32 MB RAM, wide format printing, two 500-sheet trays, a 100-sheet multipurpose tray, and an HP JetDirect EIO print server.

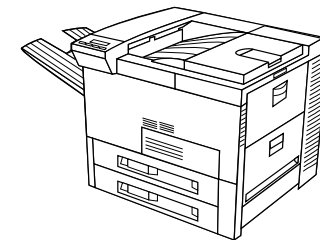

**Continued on next page.**



### ***HP LaserJet 8150 DN printer***

The HP LaserJet 8150 DN printer (product number C4267A) comes standard with 32 MB RAM, wide format printing, two 500-sheet trays, a 100-sheet multipurpose tray, an HP JetDirect EIO print server, and a duplexer (for printing on both sides of paper).

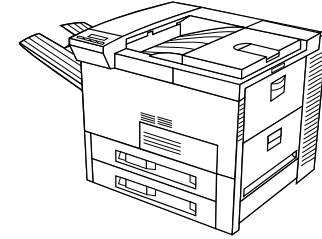

### ***HP LaserJet 8150 HN printer***

The HP LaserJet 8150 HN printer (product number C4269A) comes standard with 32 MB RAM, wide format printing, two 500-sheet trays, a 100-sheet multipurpose tray, a 2000-sheet input tray (tray 4), a 3000-sheet stacker, an HP JetDirect EIO print server, and a duplexer (for printing on both sides of paper).

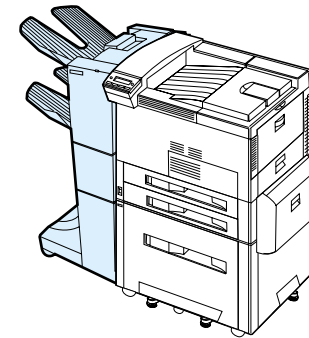

**Continued on next page.**



## ***HP LaserJet 8150 MFP printer***

The HP LaserJet 8150 MFP (product number C4268A) comes standard with 64 MB RAM, wide format printing, hard disk, two 500-sheet trays, a 100-sheet multipurpose tray, a 2000-sheet input tray (tray 4), a 3000-sheet Stapler/Stacker, an HP JetDirect EIO print server, a duplexer (for printing on both sides of paper), a copy connect EIO board, and an HP Digital Copy.

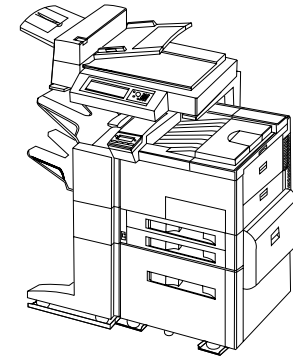

## Printer Parts and Locations

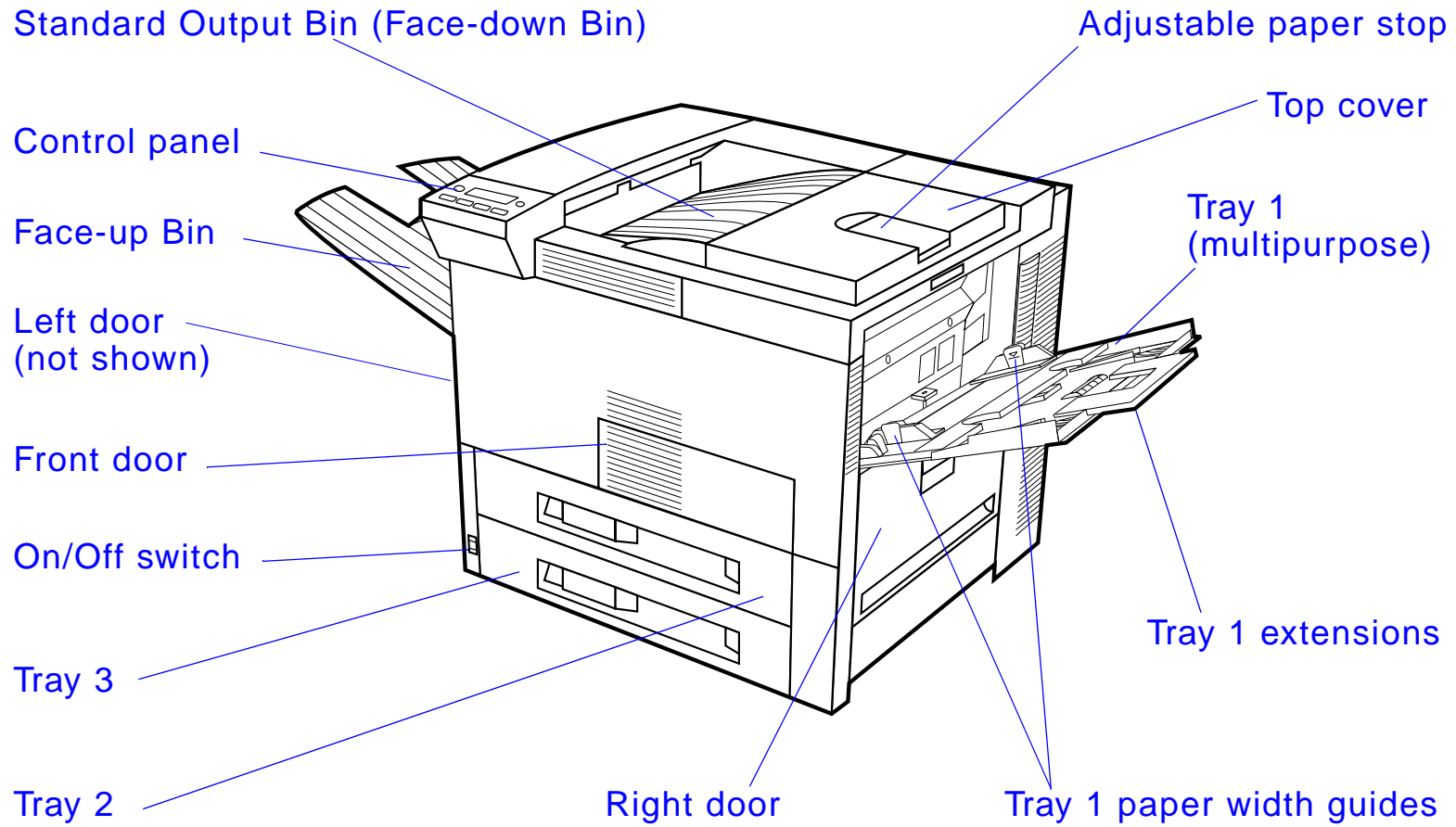

Continued on next page.



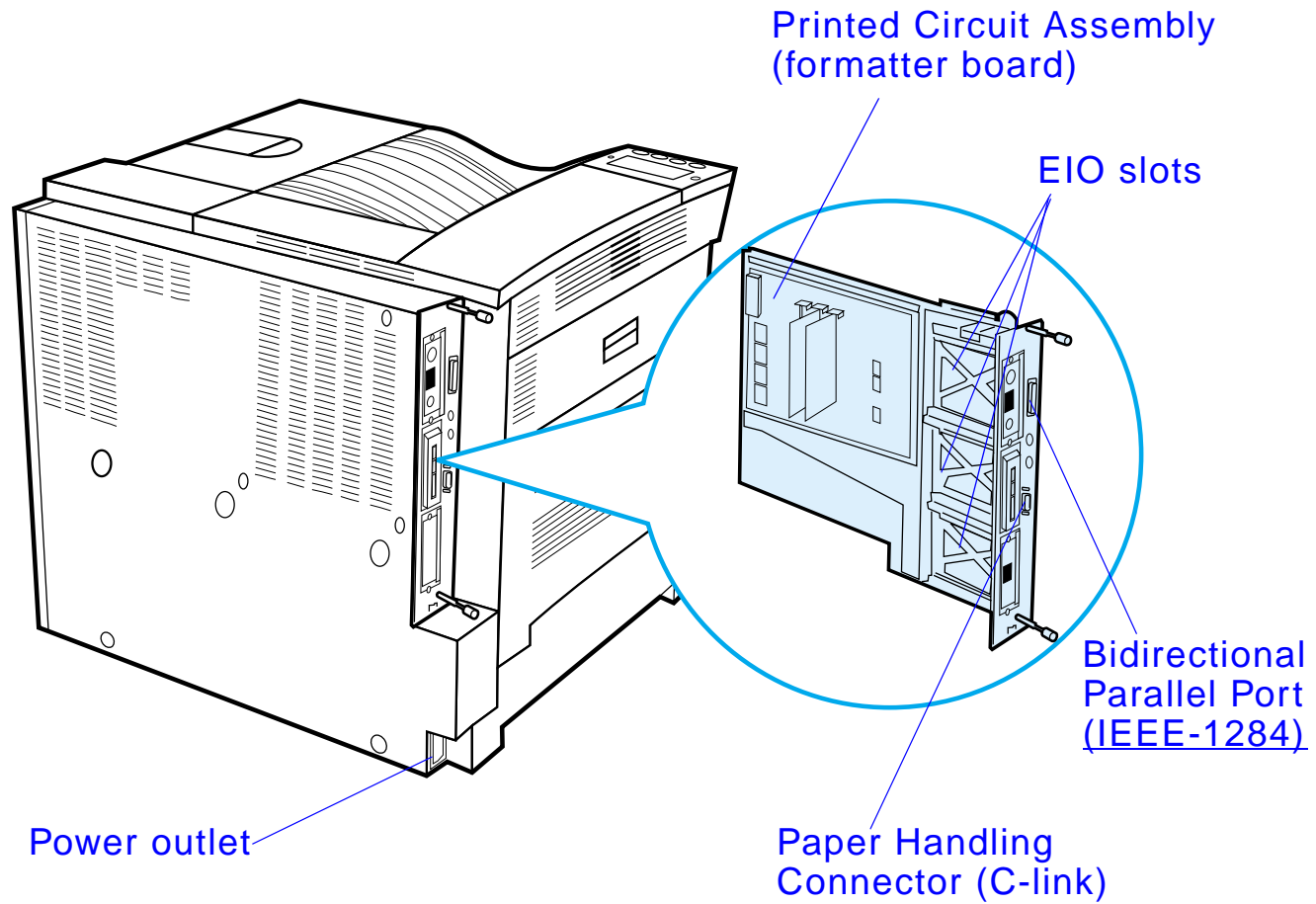

## *Accessories and Supplies*

You can increase the capabilities of the printer with optional accessories and supplies.

Use accessories and supplies specifically designed for the printer to ensure optimum performance.

The printer supports three enhanced input/output (EIO) cards. Other accessories and options are available. For ordering information, see page [42](#).



# Suggested Accessories

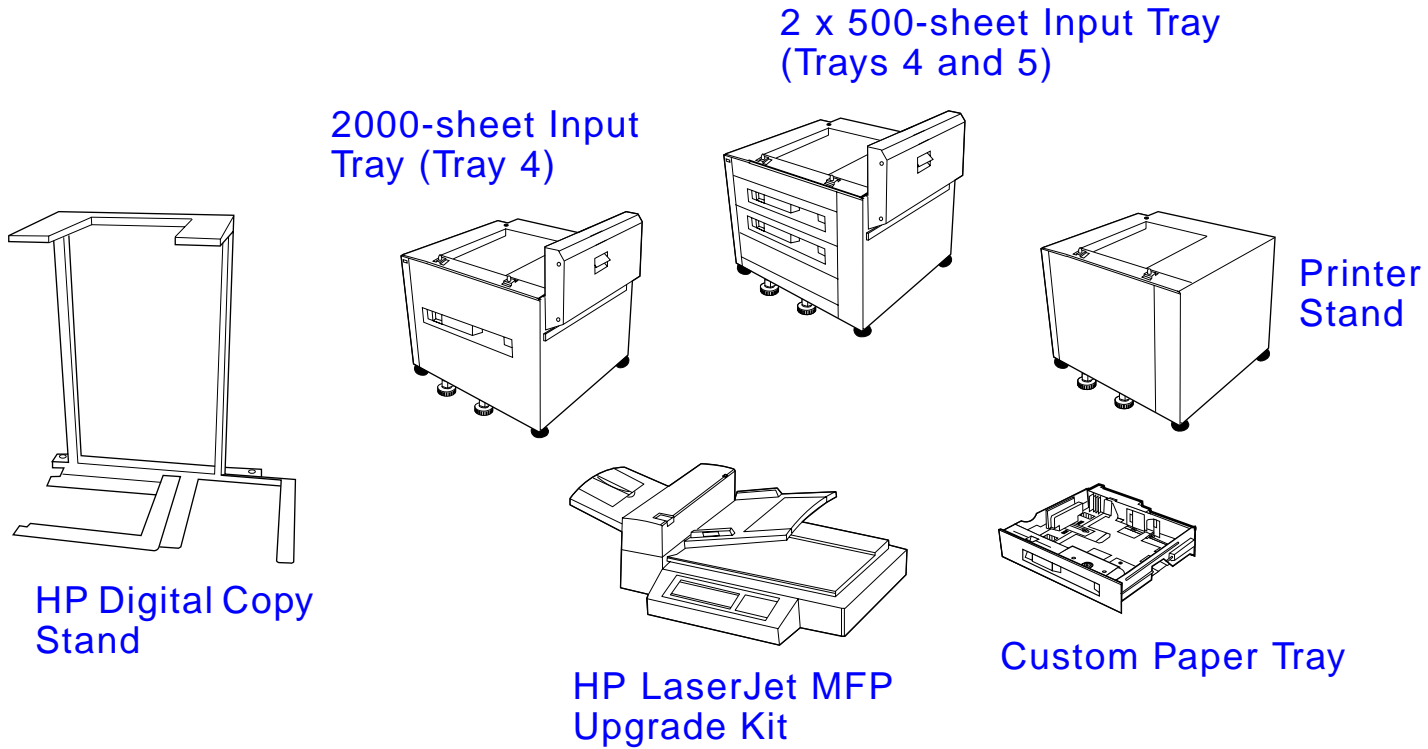

Continued on next page.



5-bin Mailbox  
with Stapler

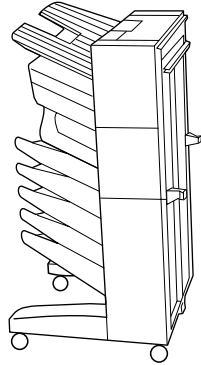

3000-sheet  
Stapler/Stacker  
or 3000-sheet  
Stacker

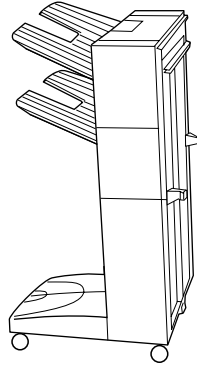

8-bin Mailbox

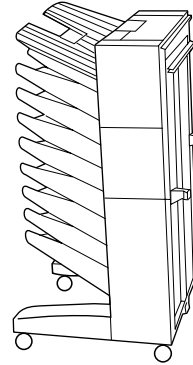

7-bin Tabletop  
Mailbox

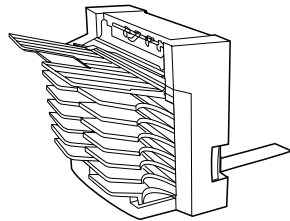

Duplexer

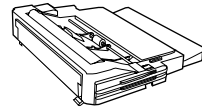

Envelope  
Feeder

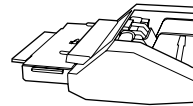

HP Fast InfraRed  
Connect



Continued on next page.



## ***Optional Hard Disk***

The Hard Disk accessory can be used to store selected print jobs, support RIP ONCE technology, and permanently store downloaded fonts and forms in the printer. Unlike standard printer memory, many items on the Hard Disk remain in the printer even when the printer is turned off. Fonts downloaded to the Hard Disk are available to all users of the printer.

The Hard Disk can be write-protected through software for additional security.

### **Windows Users**

Use HP LaserJet Resource Manager to delete files and manage fonts on a mass storage device (page [86](#)). For more information, see the printer software help.

HP is constantly introducing new software tools for use with your printer and accessories. These tools are available from the Internet free of charge. See page [3](#) for how to visit the HP website for more information.

**Continued on next page.**





### **Macintosh Users**

Use the HP LaserJet Utility to download fonts and files. See [HP LaserJet Utility \(Macintosh\)](#) on page [81](#) or the HP LaserJet Utility Guide online help included with your HP LaserJet Utility software for more information.



**Note**

The HP LaserJet Utility is not supported for Traditional Chinese, Simplified Chinese, Korean, Japanese, Czech, Russian, and Turkish.



## Ordering Information

Use only accessories specifically designed for this printer. To order an accessory, contact an HP-authorized service or support provider. (See the [HP Customer Care](#) pages at the front of this user guide.)



	<b>Item</b>	<b>Description or Use</b>	<b>Order Number</b>
<b>Paper Handling</b>	2 x 500-sheet Input Tray	Two 500-sheet trays and feeder.	C4780A
	2000-sheet Input Tray	One 2000-sheet tray and feeder.	C4781A
	Envelope Feeder	Automatically feeds up to 100 envelopes.	C3765B
	Custom Paper Tray	Allows printing on custom-size paper.	C4184A
	Duplex Printing Accessory (duplexer)	Allows automatic printing on both sides of paper.	C4782A



Item	Description or Use	Order Number	
<b>Paper Handling (continued)</b>	7-bin Tabletop Mailbox	Each of the 7 output bins holds 120 sheets of paper.	C4783A
	8-bin Mailbox	Each of the 8 output bins holds 250 sheets of paper.	C4785A
	5-bin Mailbox with Stapler	Each of the 5 output bins holds 250 sheets of paper. Provides job separation by stapling jobs.	C4787A
	3000-sheet Stacker	One 3000-sheet stacking device.	C4779A
	3000-sheet Stapler/Stacker	One 3000-sheet stacking device provides stapling for up to 50 sheets of paper per document.	C4788A



	Item	Description or Use	Order Number
<b>Paper Handling (continued)</b>	HP LaserJet MFP Upgrade Kit	A copy module that comes standard with 32 cpm, duplexing, and wide format copying.	C4166A
<b>Printer Stands</b>	Printer Stand	Used in place of the 2000-sheet Input Tray (Tray 4) or the 2 x 500-sheet Tray (Trays 4 and 5) when an output accessory is attached. <b>Note:</b> The printer stand cannot be used with the stand for the HP Digital Copy.	C2975A
	Stand for the HP Digital Copy.	This is the preferred configuration for the printer and copy module.	C4231A





	<b>Item</b>	<b>Description or Use</b>	<b>Order Number</b>
<b>Printing Supplies</b>	HP Multipurpose Paper (Other HP media is available where office products are sold.)	HP brand paper for a variety of uses (1 box of 10 reams, 500 sheets each). To order a sample, in the U.S. call 1-800-471-4701.	HPM1120
	HP LaserJet Paper (Other HP media is available where office products are sold.)	Premium HP brand paper for use with HP LaserJet printers (1 box of 10 reams, 500 sheets each). To order a sample, in the U.S. call 1-800-471-4701.	HPJ1124
	Toner Cartridge (20,000 pages)	Replacement HP UltraPrecise toner cartridge.	C4182X





---

	<b>Item</b>	<b>Description or Use</b>	<b>Order Number</b>
<b>Printing Supplies (continued)</b>	Staple Cartridges (5-bin Mailbox with Stapler)	3-pack of staple cartridges. Each cartridge contains 2000 staples.	C3772A
	Staple Cartridges (3000-sheet Stapler/Stacker)	3-pack of staple cartridges. Each cartridge contains 5,000 staples.	C4791A



	Item	Description or Use	Order Number
<b>Memory, Fonts, and Mass Storage</b>	Dual In-line Memory Module (DIMM) (100-pin)	Boosts the ability of the printer to handle large print jobs (maximum 160 MB with HP brand DIMMs)	
	SDRAM DIMMs (100-pin)	8 MB 16 MB 32 MB 64 MB	C7842A C7843A C7845A C7846A
	Flash DIMM (100-pin)	Permanent storage for fonts and forms:  2 MB 4 MB 8 MB	C4286A C4287A C8530A
	Font DIMM (100-pin)	8 MB Asian ROM: Traditional Chinese Simplified Chinese	C4292A C4293A



Item	Description or Use	Order Number	
<b>Memory, Fonts, and Mass Storage (continued)</b>	Hard Disk	Permanent storage for fonts and forms. Enables RIP ONCE mopying of print jobs that are too large to RIP ONCE mopy in RAM (see pages <a href="#">147</a> and <a href="#">166</a> ).	C2985B
<b>Cable and Interface Accessories</b>	Parallel Cables	3 Meter IEEE-1284 cable 10 Meter IEEE-1284 cable	C2946A C2947A
	Macintosh Network Cable Kit	For PhoneNET or LocalTalk connection.	92215N
	(Requires EIO card)	1-to-1 connection (Macintosh DIN-8 cable male-male).	92215S





	Item	Description or Use	Order Number
<b>Cable and Interface Accessories (continued)</b>	Enhanced I/O Cards	HP JetDirect print server multi-protocol EIO network cards:	
		● Ethernet RJ-45 only	J3110A
		● Ethernet RJ-45 and BNC, LocalTalk	J3111A
		● Token Ring RJ-45 and DB-9	J3112A
		● Fast Ethernet 10/100Base-TX RJ-45 only	J4169A
		HP JetDirect Connectivity card for:	
		● USB, Serial, LocalTalk	J4135A
	HP Fast InfraRed Connect	Enables wireless printing from any IRDA-compliant portable device (such as a laptop computer).	C4103A



	Item	Description or Use	Order Number
<b>Cable and Interface Accessories (continued)</b>	Power Box	For connecting a multibin mailbox to the printer when the printer is on a printer stand. This item is included only with the 2000-sheet Input Tray and the 2 x 500-sheet Input Tray.	C4789A
	<b>Maintenance Kit</b>	Preventive Maintenance Kit	Contains replacement fuser, transfer roller, and feed and separation rollers.  For 110V units C3914A For 220V units C3915A
<b>Documentation</b>	<i>HP LaserJet Printer Family Paper Specification Guide</i>	A guide to using paper and other print media with HP LaserJet printers.	5090-3392



	Item	Description or Use	Order Number
<b>Documentation (continued)</b>	<i>PCL 5/PJL Technical Reference Documentation Package</i>	A guide to using printer commands with HP LaserJet printers.	5021-0377
	<i>HP LaserJet 8150, 8150 N, 8150 DN, 8150 HN, and 8150 MFP Printers User Guide</i>	This is an online user guide provided on compact disc. This CD-ROM contains all supported languages.	C4265-60104
	User Documentation Bundle	An additional copy of the getting started guide and the ready reference guide. Available in all supported languages.	C4265-99001 (English version)
	HP 3000-sheet Stacker and HP 3000-sheet Stapler/Stacker (C4779x and C4788x) Installation Guide	Instructions for installing the 3000-sheet Stacker and 3000-sheet Stapler/Stacker.	C4788-90900



---

Item	Description or Use	Order Number
<b>Documentation (continued)</b>	HP 3000-sheet Stacker and HP 3000-sheet Stapler/Stacker (C4779x and C4788x) User Guide	C4788-90901

---



# Control Panel Layout

The control panel includes three indicator lights, six keys, and a 2-line display (16 characters per line).

2-line display

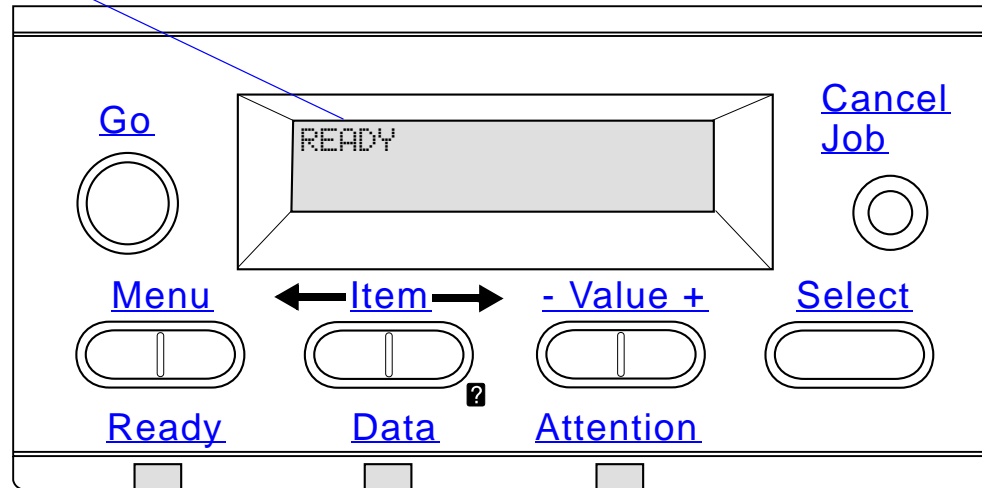

## Control Panel Lights



---

Light	Indication
Ready	
Off	The printer is offline or has an error.
Solid	The printer is ready to print.
Blinking	The printer is going offline, please wait.
Data	
Off	The printer has no data to print.
Solid	The printer has data to print, but is not ready or is offline.
Blinking	The printer is processing or printing the data.



---

Light	Indication
Attention	
Off	The printer has no error.
Solid	The printer has a problem. Turn the printer off and then on.
Blinking	Action is required. See the control panel display.

---



## Configuration Page

To print a configuration page, see page [314](#).



## Control Panel Keys



Key	Function
Go	<ul style="list-style-type: none"> <li>● Places the printer either online or offline.</li> <li>● Prints any data residing in the printer's buffer.</li> <li>● Allows the printer to resume printing after being offline. Clears most printer messages and places the printer online.</li> <li>● Allows the printer to continue printing with an error message such as TRAY x LOAD [TYPE] [SIZE] or UNEXPECTED PAPER SIZE.</li> <li>● Confirms a manual feed request if Tray 1 is loaded and TRAY 1 MODE=CASSETTE has been set from the Paper Handling Menu in the printer's control panel.</li> <li>● Overrides a manual feed request from Tray 1 by selecting paper from the next available tray.</li> <li>● Exits the control panel menus. (To save a selected control panel setting, first press <b>SELECT</b>.)</li> </ul>
CANCEL JOB	<p>Cancels the print job that the printer is processing. The time it takes to cancel depends on the size of the print job. (Press it only once.)</p>





---

Key	Function
MENU	Cycles through the control panel menus. Press the right end of the button to move forward or the left end of the button to move backward.
ITEM	Cycles through the selected menu's items. Press the right end of the button to move forward or the left end of the button to move backward. The Item key is also used to navigate through the printer's online Help system (see page <a href="#">227</a> ).
- VALUE +	Cycles through the selected menu item's values. Press + to move forward or - to move backward.
SELECT	<ul style="list-style-type: none"><li>● Saves the selected value for that item. An asterisk (*) appears next to the selection, indicating that it is the new default. Default settings remain when the printer is switched off or reset (unless you reset all factory defaults from the Resets Menu).</li><li>● Prints one of the printer information pages from the control panel.</li></ul>

---



## Control Panel Menus

For a complete list of control panel items and possible values, see page [420](#).

Press **MENU** for access to all control panel menus. When additional trays or other accessories are installed in the printer, new menu items automatically appear.

### ***To change a control panel setting:***

- 1 Press **MENU** repeatedly until the desired menu appears.
- 2 Press **ITEM** repeatedly until the desired item appears.
- 3 Press **- VALUE +** repeatedly until the desired setting appears.
- 4 Press **SELECT** to save the selection. An asterisk (\*) appears next to the selection in the display, indicating that it is now the default.
- 5 Press **GO** to exit the menu.

**Continued on next page.**



---

**Note**

Settings in the printer driver and software application override control panel settings. (Software application settings override printer driver settings.)

If you cannot access a menu or item, it is either not an option for the printer, or your network administrator has locked the function. (The control panel reads ACCESS DENIED MENUS LOCKED.) See your network administrator.

---



***To print a control panel menu map:***

See page [317](#) for information on how to print a control panel menu map.



## *Paper Handling LED Status Interpretation*

Use the following table to interpret the status lights on the Optional 2000-sheet Input Tray (Tray 4), the Optional 2 x 500-sheet Input Tray (Trays 4 and 5), and the optional HP output devices.



Light	Optional 2000-sheet Input Tray and the Optional 2 x 500-sheet Tray (Trays 4 and 5)	Optional HP Output Devices
<b>Solid Green</b>	The accessory is on and ready.	The accessory is on and ready.
<b>Solid Amber</b>	The accessory is experiencing a hardware malfunction.	The accessory is experiencing a hardware malfunction.





Light	Optional 2000-sheet Input Tray and the Optional 2 x 500-sheet Tray (Trays 4 and 5)	Optional HP Output Devices
<b>Flashing Amber</b>	<p>The accessory has a paper jam or a page needs to be removed from the tray, even if the page is not jammed.</p> <p>The lower right door might be open.</p>	<p>The accessory has a paper jam or a page needs to be removed from the multibin mailbox, even if the page is not jammed.</p> <p>The accessory is not correctly attached to the printer.</p>
<b>Off</b>	<p>The printer might be in Power Save mode. Press <b>Go</b>.</p> <p>The accessory is not receiving power. Check the power supply, power cables, and C-link cables.</p>	<p>The printer might be in Power Save mode. Press <b>Go</b>.</p> <p>The accessory is not receiving power. Check the power supply, power cables, and C-link cables.</p>

# Printer Software

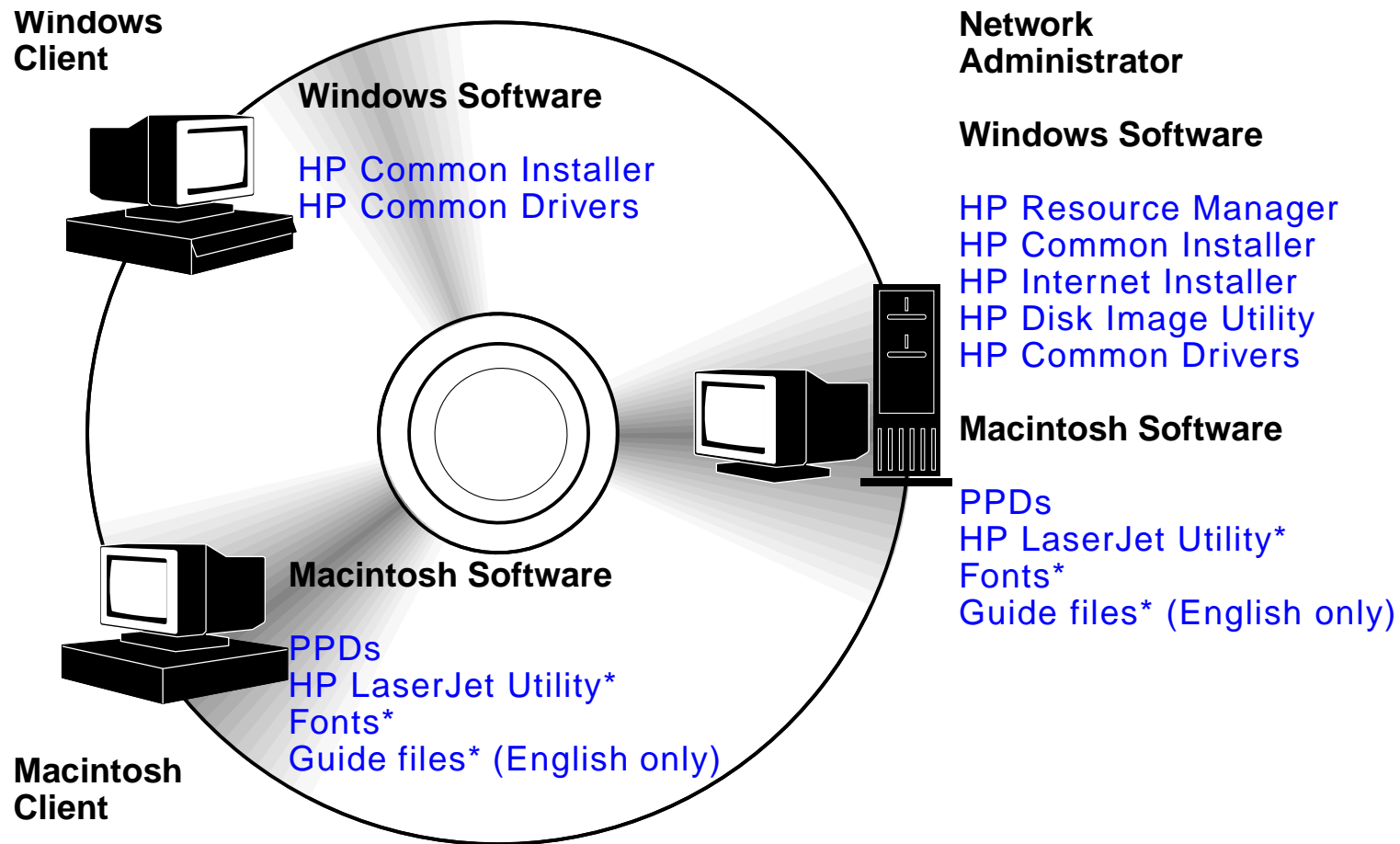

\* These products are not supported in Traditional Chinese, Simplified Chinese, Korean, Japanese, Czech, Russian, and Turkish.

The printer drivers provided on the compact disc must be installed to take full advantage of the printer's features. The other software programs are recommended, but are not required for operation. See the ReadMe file for more information.



---

**Note**

Network Administrators: HP LaserJet Resource Manager should be installed only on the network administrator's computer. Load all other applicable software on the server and all client computers.

To manage printers, open the server-based tool (HP Web JetAdmin) in your web browser. For more information, go to [www.hp.com/go/webjetadmin](http://www.hp.com/go/webjetadmin)

---



The most recent drivers, additional drivers, and other software are available from the Internet. Depending on the configuration of Windows-driven computers, the installation program for the printer software automatically checks the computer for Internet access to obtain the latest software. If you do not have access to the Internet, see the [HP Customer Care](#) pages at the front of this user guide to obtain the most recent software.

Included with the printer is a compact disc containing the HP LaserJet Printing System. On the compact disc are software components and drivers that benefit end users and network administrators. See the ReadMe file for the most current information.

**Continued on next page.**



The Printing System includes software designed for end users operating in the following environments:

- Microsoft Windows 3.1x
- Microsoft Windows 9x
- Microsoft Windows NT 4.0
- Windows 2000
- IBM OS/2 version 2.0 or greater
- Apple Mac OS 7.5 or greater
- AutoCad

The Printing System also includes software for network administrators using the following network operating systems:

- Novell NetWare 3.x, 4.x, or 5.x
- Microsoft Windows 9x
- Microsoft Windows NT 4.0 or Windows 2000
- Apple AppleTalk (LocalTalk or EtherTalk)

**Continued on next page.**





Network printer installation for UNIX and other network operating systems is available from the web or through your HP distributor. (See the [HP Customer Care](#) pages at the front of this user guide.)



The drivers and software components for end users and administrators using the environments listed above are described in the following sections.



## *Printer Drivers*

Printer drivers access the printer features and allow the computer to communicate with the printer.

### *Windows*

See [Access the Windows Printer Driver](#) on page [75](#) for more specific driver information.

### *Macintosh*

See [Apple LaserWriter 8 Driver](#) on page [80](#) for more specific driver information.



---

#### **Note**

---

Check the “Installation Notes” file provided on the compact disc for additional software included and supported languages.



## *Drivers Included with the Printer*

The following printer drivers are included with the printer. The most recent drivers are available on the Internet. (See the [HP Customer Care](#) pages at the front of this user guide.) Depending on the configuration of Windows computers, the installation program for the printer software automatically checks the computer for Internet access to obtain the latest drivers.

	<b>PCL 5e</b>	<b>PCL 6</b>	<b>PS<sup>a</sup></b>
Windows 3.1x	✓	✓	✓
Windows 9x	✓	✓	✓
Windows NT 4.0	✓	✓	✓
Windows 2000	✓	✓	✓
Macintosh computer <sup>b</sup>			

- PostScript Level 3 emulation is referred to as PS throughout this user guide.
- Only PPDs are included (see page [80](#)). If you need the Apple LaserWriter 8 driver, it comes with the Mac OS system software or can be obtained directly from Apple Computer, Inc.

**Continued on next page.**



From the tables below, choose the appropriate installation option for what you want installed on your system.



**Windows installation**

<b>Typical Install</b>	Select <b>Typical Install</b> to install the following: <ul style="list-style-type: none"><li>● PCL 6</li><li>● Bi-directional communication</li><li>● Fonts</li><li>● Stand-alone status</li></ul>
<b>Custom Install</b>	Select <b>Custom Install</b> to: <ul style="list-style-type: none"><li>● Copy drivers only (PCL 6, PCL 5e, and PS)</li><li>● Create customized installer (PCL 6, PCL 5e, PS, bi-directional communications, fonts, stand-alone status, and Resource Manager)</li><li>● Copy entire printing system installer</li></ul>



Continued on next page.



*Macintosh installation*

<b>Install</b>	Select <b>Install</b> to install the following: <ul style="list-style-type: none"><li>● PPD file for use with PostScript printer drivers</li><li>● HP LaserJet Utility</li><li>● Online help</li></ul>
<b>Custom</b>	Select <b>Custom</b> to only install the software you prefer.



## ***Additional Drivers***

The following additional printer drivers are included with the printer.

- OS/2 PCL/PCL 6 printer driver
- OS/2 PS printer driver
- AutoCAD



---

### **Note**

If the desired printer driver is not on the compact disc or is not listed here, check the software application's installation disks or ReadMe files to see if they include support for the printer. If not, contact the software manufacturer or distributor and request a driver for the printer.

---



## Software for Windows

Use the printing system software to install the printer. If you are installing the printer on a network (Novell NetWare or Microsoft Windows network) from a Windows 9x, NT, or 2000 system, the printing system software will guide you through the installation process and will properly configure the network printer.



---

### Note

If the printer will be used on a network, the network clients and servers must be properly configured to communicate on the network.

For additional network printer configuration and management, use HP Web JetAdmin.

HP Web JetAdmin is a server-based tool that network administrators can access using their web browser. For supported host systems and available languages or to download the software, go to [www.hp.com/go/webjetadmin](http://www.hp.com/go/webjetadmin)

---



## *Installing Windows Printing Software (CD)*

### *For Windows 9x, Windows NT 4.0, and Windows 2000*

- 1 Close all running applications.
- 2 Insert the CD ROM into the CD-ROM drive. (Depending on the computer configuration, the installation program may automatically start.)
- 3 Click **Start**.
- 4 Click **Run**.
- 5 Type **D:\SETUP** (or the appropriate drive directory letter) in the command line box and click **OK**.
- 6 Follow the instructions on the computer screen.

**Continued on next page.**





***For Windows 3.1x***

- 1 Close all running applications.
- 2 Insert the CD ROM into the CD-ROM drive.
- 3 In the **Windows Program Manager** screen, click the **File** menu.
- 4 Click **Run**.
- 5 Type **D:\SETUP** (or the appropriate drive directory letter) in the command line box and click **OK**.
- 6 Follow the instructions on the computer screen.



## Installing Macintosh Printing Software

**Note** Read the “Installation Notes” on the CD-ROM.

- 1 Quit all open applications.
- 2 Insert the CD ROM into the CD-ROM drive.
- 3 Double-click the **Installer** icon and follow the instructions on the screen.
- 4 Open the **Chooser** from the **Apple** menu.
- 5 Click the **LaserWriter 8** icon. If the icon is not there, contact [HP Customer Care](#) or contact Apple Computer, Inc.
- 6 If you are on a network with multiple zones, select the zone in the **AppleTalk Zones** box where the printer is located. If this is unknown, ask your network administrator.
- 7 Select the desired printer name on the right side of the Chooser. An icon should appear.
- 8 Close the **Chooser** by clicking the Close box in the upper left corner.



## *Access the Windows Printer Driver*

To configure the driver once the software is installed, access it in one of the following ways:



<b>Operating System</b>	<b>Temporarily Change Settings (from a software application)</b>	<b>Change Default Settings (across all applications)</b>
Windows 9x	From the <b>File</b> menu, click <b>Print</b> , and then click <b>Properties</b> . (The actual steps can vary; this is the most common method.)	Click the <b>Start</b> button, point to <b>Settings</b> , and then click <b>Printers</b> . Right-click the printer icon, and choose <b>Properties</b> .
Windows NT 4.0/Windows 2000	From the <b>File</b> menu, click <b>Print</b> , and then click <b>Properties</b> . (The actual steps can vary; this is the most common method.)	Click the <b>Start</b> button, point to <b>Settings</b> , and then click <b>Printers</b> . Right-click and choose <b>Document Defaults</b> to change setup attributes (for example; orientation, paper size, trays), or choose <b>Properties</b> to configure, add, or change accessories.

Continued on next page.



Operating System	Temporarily Change Settings (from a software application)	Change Default Settings (across all applications)
Windows 3.1x	From the <b>File</b> menu, click <b>Print</b> , click <b>Printers</b> , and then click <b>Options</b> . (The actual steps can vary; this is the most common method.)	From the Windows control panel, double-click <b>Printers</b> , highlight the printer, and click <b>Setup</b> .



**Note** Settings in the printer driver and software application override the printer's control panel settings. (Software application settings override printer driver settings.)



## ***Choose the Right Printer Driver for Your Needs***

For Windows, choose a printer driver based on the way you use the printer.

- Use the PCL 6 driver to take full advantage of the printer's features. Unless backward compatibility with previous PCL drivers or older printers is necessary, the PCL 6 driver is recommended.
- Use the PCL 5e driver if you want print results to look comparable to those from older printers.
- Use the PS driver for compatibility with PostScript Level 3 needs.
- The printer automatically switches between PS and PCL printer languages.

For the Macintosh, use the Apple LaserWriter 8 Driver, which is a PS driver.

## ***Printer Driver Help***

Each printer driver has help screens that can be activated either from the Help button, the F1 key, or a question mark symbol in the upper right corner in the printer driver (depending on the Windows operating system used). These help screens give detailed information about the specific driver. Printer driver help is separate from the software application help.



## ***HP JetSend Communications Technology***



HP JetSend is a new technology from Hewlett-Packard that allows devices to communicate with each other simply and directly. HP JetSend is built into your printer, allowing it to receive information from any JetSend-enabled sending device anywhere on your network, whether it is in the same office or at a remote location. When you use the HP Fast InfraRed Connect accessory, your printer can also receive information from any JetSend-enabled infrared device. Examples of JetSend sending devices include PCs or laptops running JetSend software or scanners with JetSend built in. JetSend uses simple IP addressing between networked devices and “point and shoot” between infrared devices.



---

**Note**

HP JetSend is not supported for Traditional Chinese, Simplified Chinese, Korean, Japanese, Czech, Russian, and Turkish.

Visit the JetSend web site ([www.jetsend.hp.com](http://www.jetsend.hp.com)) to download the JetSend software. You will then be able to exchange intra-company documents directly between PCs and between PCs and any JetSend-enabled printer, without the problems of incompatible software applications or versions. JetSend software will allow your colleagues to create documents on their PCs and send copies directly to this printer without any device-specific drivers or configuration difficulties.

**Continued on next page.**



You can visit the JetSend web site to learn which other devices are available to communicate easily and directly with your JetSend-enabled printer.



### **How the JetSend Communications Technology Works**

#### *Networked Devices*

To use the JetSend capability between networked devices, print a configuration page (see page [314](#)) to find your JetSend IP address, and give your address to anyone who wants to send information to your printer via JetSend.



From a JetSend sending device, a person only needs to enter the printer's IP address and press "send."



#### *Infrared Devices*

To use JetSend infrared capability, line up the infrared sensors between the sending and receiving devices, and choose the "send" option on the sending device.

The devices will automatically negotiate the best possible outcome because they have JetSend in them.

**Note**

HP JetSend is not available for the Macintosh.



## *Software for Macintosh Computers*

### *Apple LaserWriter 8 Driver*

The driver for the Apple LaserWriter 8 comes with the Mac OS system software or can be obtained directly from Apple Computer, Inc.

### *PostScript Printer Description Files (PPDs)*

PPDs, in combination with the Apple LaserWriter 8 Driver, access the printer features and allow the computer to communicate with the printer. An installation program for the PPDs and other software is provided on the compact disc. Use the Apple LaserWriter 8 Driver that comes with the computer.

**Continued on next page.**





## ***HP LaserJet Utility (Macintosh)***

**Note** The HP LaserJet Utility is not supported for Traditional Chinese, Simplified Chinese, Korean, Japanese, Czech, Russian, and Turkish.

HP LaserJet Utility allows control of features that are not available in the driver. The illustrated screens make selecting printer features from the Macintosh computer easier than ever. Use the HP LaserJet Utility to do the following:

- Customize the printer's control panel messages.
- Name the printer, assign it to a zone on the network, download files and fonts, and change most of the printer settings.
- Set a password for the printer.
- From the computer, lock out functions on the printer's control panel to prevent unauthorized access. (See the printer software help.)
- Configure and set the printer for IP printing.
- Initialize disk or flash memory.
- Manage fonts in RAM, disk, or flash memory.
- Administer Job Retention features.

See the LaserJet utility guide for more information.



## *Fonts*

**Note** Fonts are not supported for Traditional Chinese, Simplified Chinese, Korean, and Japanese on Macintosh computers.

Forty-five screen fonts are installed that correspond with the PS fonts resident in the printer.



## Software for Networks

### ***HP Web JetAdmin***

This browser-based HP Web JetAdmin software can be installed on any supported server platform. The following systems are supported:<sup>1</sup>

- Microsoft Windows NT 4.0 or Windows 2000
- HP-UX
- Sun Solaris
- Red Hat Linux
- SuSE Linux

Once installed, HP Web JetAdmin allows any client PC with a supported web browser to administer the printer.

For the latest list of supported server platforms, go to [www.hp.com/go/webjetadmin](http://www.hp.com/go/webjetadmin)

**Continued on next page.**

---

1. HP Web JetAdmin is not included on the compact disc with the printer, but is available from the Internet (<http://www.hp.com/go/webjetadmin>). If you do not have access to the Internet, see the [HP Customer Care](#) pages at the front of this user guide to obtain this software.



---

**Note** The HP Web JetAdmin web site allows access to HP Web JetAdmin in many languages.

---



Use HP Web JetAdmin to do the following:

- Install and configure printers that are connected to a network with an HP JetDirect print server.
- Manage and troubleshoot network printers from any location.



### ***HP JetDirect Printer Installer for UNIX***

The HP JetDirect Printer Installer for UNIX is a simple printer installation utility for HP-UX and Sun Solaris network systems. For more information or to download the software, go to [www.hp.com/support/net\\_printing](http://www.hp.com/support/net_printing).



## ***HP LaserJet Utility (Macintosh)***

HP LaserJet utility allows control of features that are not available in the driver. The illustrated screens make selecting printer features from the Macintosh computer easier than ever. Use the HP LaserJet Utility to do the following:

- Customize the printer's control panel messages.
- Name the printer, assign it to a zone on the network, download files and fonts, and change most of the printer settings.
- Set a password for the printer.
- From the computer, lock out functions on the printer's control panel to prevent unauthorized access. (See the printer software help.)
- Configure and set the printer for IP printing.
- Initialize disk or flash memory.
- Manage fonts in RAM, disk, or flash memory.
- Administer Job Retention features.

See the LaserJet utility guide for more information.



---

### **Note**

The HP LaserJet Utility is not supported for Traditional Chinese, Simplified Chinese, Korean, Japanese, Czech, Russian, and Turkish.



## *HP LaserJet Resource Manager*



**Note** The hard disk and flash memory DIMMs are optional printer accessories.

The HP LaserJet Resource Manager should be installed only on the network administrator's computer. The HP LaserJet Resource Manager allows you to control hard disk and flash memory features not found in the drivers. Bidirectional communication is required.



**Note** HP LaserJet Resource Manager is not available for the Macintosh.

If you are using a Macintosh, these features are available in the HP LaserJet Utility (version 3.5.1 or greater).



**Continued on next page.**



Use the HP LaserJet Resource Manager to do the following:

- Initialize disk and flash memory.
- Download, delete, and manage fonts to disk and flash memory across networks.
  - ◆ PostScript Type 1, PostScript Type 42 (True Type fonts converted to PostScript format), TrueType, and PCL bitmap fonts.
- Download, delete, and manage printer firmware across networks.



---

**Note** To download Type 1 fonts, Adobe Type Manager must be loaded and turned on.

---

- Update the HP Digital Copy firmware operating system.



# 2 *Printing Tasks*



## *Overview*

This chapter presents **basic printing tasks**, such as:

- [Loading the Input Tray](#)
- [Selecting the Output Bin](#)
- [Using the Stapler](#)
- [Printing Both Sides of Paper \(Optional Duplex Printing Accessory\)](#)
- [Printing Envelopes](#)
- [Printing Special Paper](#)

---

### **Note**

For more information on an optional HP output device, see the user guide that came with the device.

For copying information, see [HP Digital Copy](#) on page [324](#).





## Loading the Input Tray



### Loading Tray 1



**Note** For paper specifications, see page [390](#).

To customize Tray 1 operation, see page [154](#).



**CAUTION** To avoid a paper jam, never add or remove paper from Tray 1 while the printer is printing.

To avoid damaging the printer, print labels, envelopes, and transparencies only from Tray 1. Send them to the Face-up Bin, and do not print them on both sides.

When printing multiple transparencies, promptly remove each transparency as soon as it emerges from the printer (so the sheets do not stick together).

**Continued on next page.**



- 1 Open Tray 1.
- 2 Pull out the tray extension, if needed, for the paper size you are printing.
- 3 Slide the paper width guides to the appropriate size marked on the tray.
- 4 Place paper into the tray without stacking it above the paperfill mark.

**Continued on next page.**

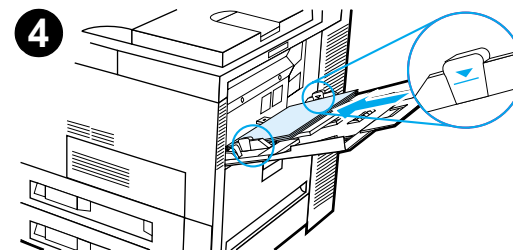
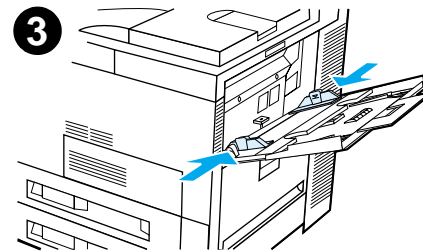
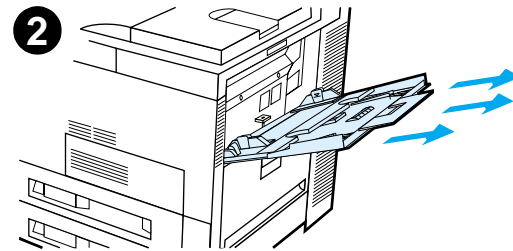
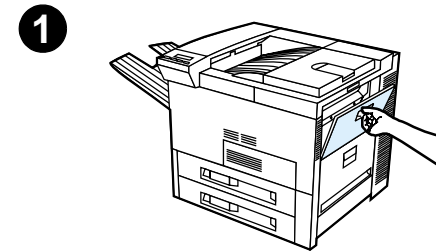

5 Paper loading differs by size:

- a Load Letter or A4 paper with the top of the page toward the rear of the printer and with the side-to-be-printed up for single-sided printing.

For two-sided printing, load paper with the top of the page toward the rear of the printer and with the first side-to-be-printed down.

- b Load short-edge fed media with the top of the page toward the printer and with the side-to-be-printed up for single-sided printing.

For two-sided printing, load media with the top of the page away from the printer and with the first side-to-be-printed down. (For more information on paper specifications, see page [390](#).)

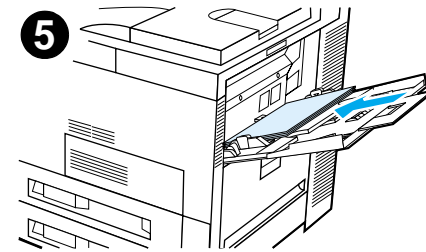

---

**Note**

See page [130](#) for more information on printing envelopes from Tray 1.

---

**Continued on next page.**



- 6 Slide the paper into the printer until paper fits squarely and firmly between the paper width guides, without bending.

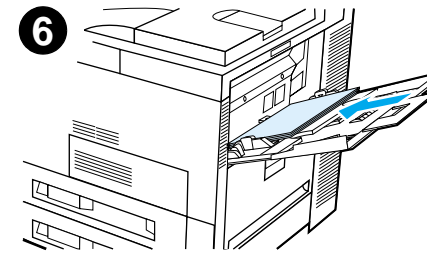

---

**Note**

Paper heavier than 28 lb (105 g/m<sup>2</sup>) should be printed from Tray 1 to the Face-up Bin to avoid curl. If you are having trouble printing on media other than plain paper, see [Changing the Variable Fuser Mode](#) on page [160](#).

If Tray 1 is in CASSETTE mode, the printer Attention light will flash. Press - **VALUE** + to change the size to match the paper size in Tray 1 and press **SELECT**.

---



## Loading Trays 2, 3, and the Optional 2 x 500-sheet Input Tray (Trays 4 and 5)



### Note

To avoid a paper jam, never open the tray while it is in use.

For paper specifications, see page [390](#).

- 1 Open the tray until it stops.
- 2 Turn the paper guide lock to the unlocked position.
- 3 Slide the paper guide to the mark that indicates the size of paper you are loading.

Continued on next page.

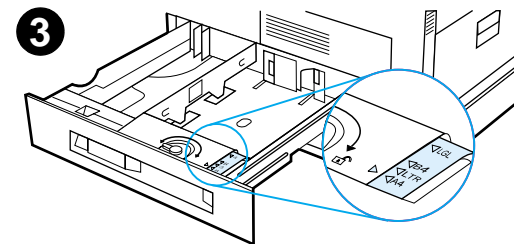
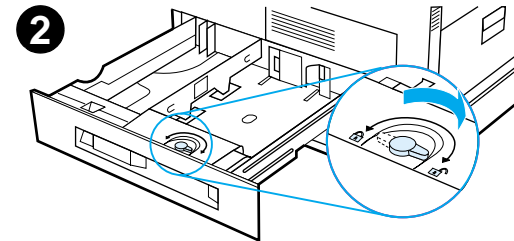
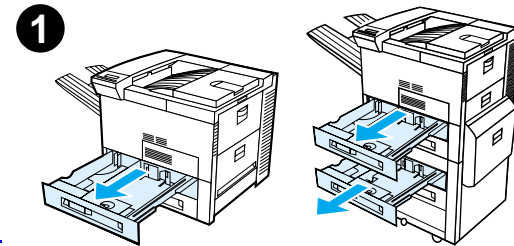

- 4 Turn the paper guide lock to the locked position.
- 5 Adjust the left paper guide by pushing back, then lifting up and out.
- 6 Position the guide over the appropriate lines marked in the tray. Press the guide into the rear slot and then lower down into the front slot. Be sure the guide is not skewed.

**Continued on next page.**

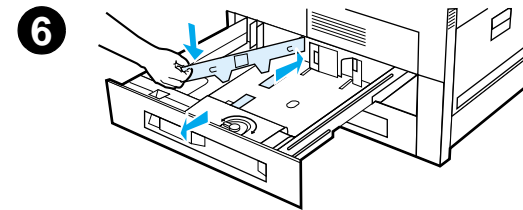
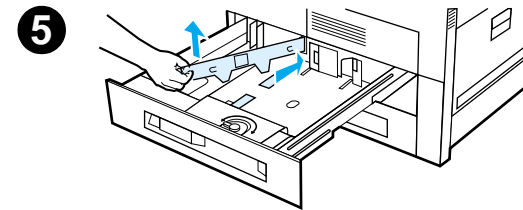
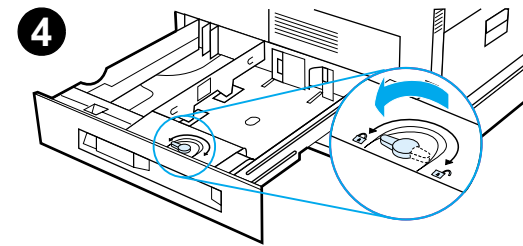

**7** Insert up to 500 sheets of paper into the tray. Do not fill the input tray above the paper fill marks on the guide.

**a** Load Letter or A4 paper with the top of the page toward the rear of the tray and with the side-to-be-printed down for single-sided printing.

For two-sided printing, load the top of the page toward the rear of the tray and with the first side-to-be-printed up.

**b** Load short-edge fed media with the top of the page toward the right side of the tray and with the side-to-be-printed down for single-sided printing.

For two-sided printing, load media with the top of the page toward the left side of the tray and with the first side-to-be-printed up.

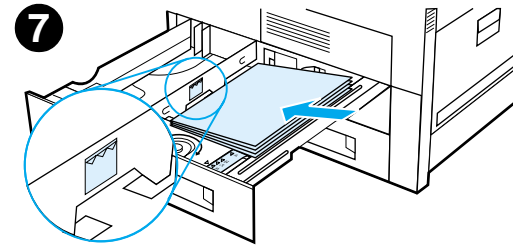

**Continued on next page.**



- 8** Make sure that the paper size tab is set correctly. Slide the tray back into the printer.

If you wish to select your paper by type rather than tray (source), see page [157](#).

Adjust the paper stop guide on the Standard Output Bin for paper sizes larger than Letter or A4. See page [104](#).

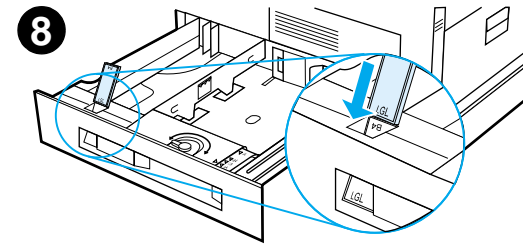



## ***Removing Excess Paper from Trays 2, 3, and the Optional 2 x 500-sheet Input Tray (Trays 4 and 5)***

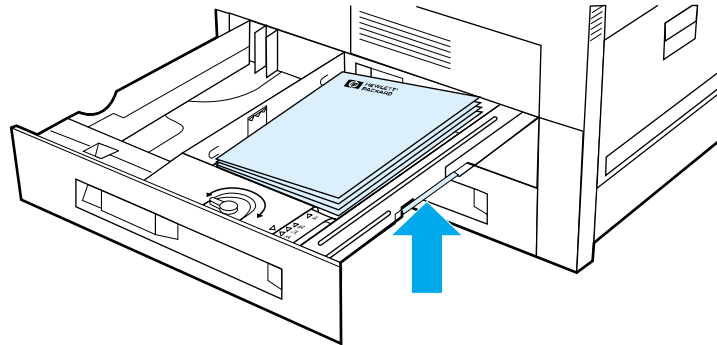

- 1 Open the tray until it stops.
- 2 Raise the paper stack and remove the excess paper.



## Loading the Optional 2000-sheet Input Tray (Tray 4)

An optional 2000-sheet Input Tray (Tray 4) is available for the printer. The tray fits under the printer and acts as a base.

---

### Note

To avoid a paper jam, never open the tray while it is in use.

---

For paper specifications, see page [390](#).

---

- 1 Slide Tray 4 open until it stops.
- 2 Pull the front guide out by the blue pin. Place the guide into the slots in the top and bottom of the input tray that correspond to the paper size you are loading and push in the pin.
- 3 Repeat step 2 to adjust the back guide.

Continued on next page.

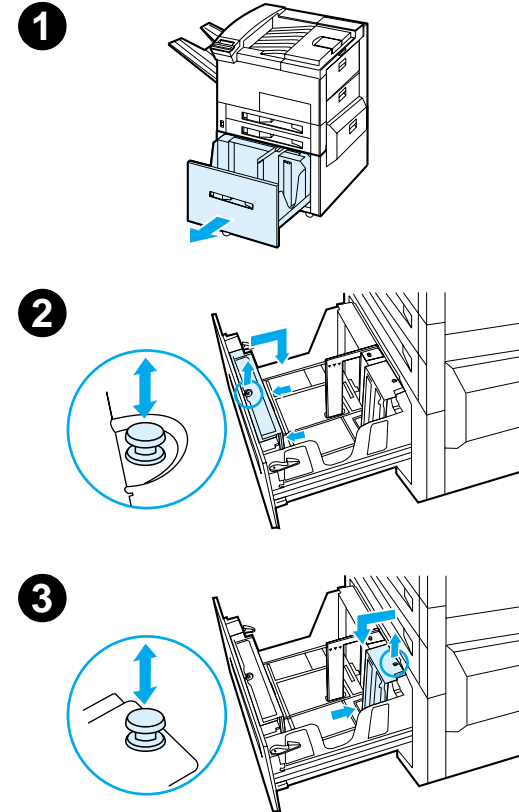

- 4 Repeat step 2 to adjust the left guide.

---

**Note**

To load 11 x 17 inch paper, move the left guide to the back of the tray. Be sure to place the left guide in the top and bottom slots marked for 11 x 17 inch paper.

---

- 5 Load up to 2000 sheets of paper into the tray. Do not allow paper to extend above the paperfill mark on the sides.

For loading instructions, see steps 7a and 7b on page [95](#).

**Continued on next page.**

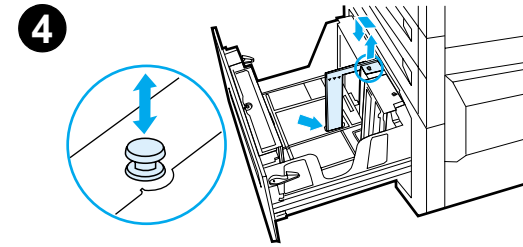

- 6 Press down on all four corners of the paper stack to ensure the paper rests flat in the tray, without bending.

**Note**

Do not store paper in the free area on the left side of Tray 4. Serious damage may occur to Tray 4.

- 7 Close Tray 4.

- 8 Make sure that the paper size tab is set correctly.

**Note**

See [Printing by Type and Size of Paper](#) on page [157](#) to set the type of paper you loaded in the tray.

If using the Standard Output Bin (face-down bin), remember to adjust the paper stop guide on the output bin. See page [104](#).

6

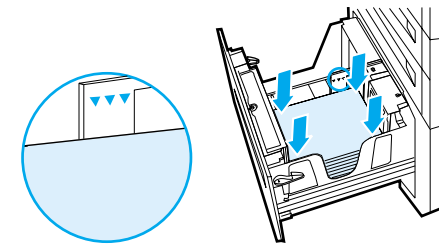

7

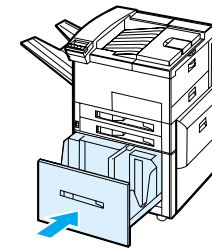

8

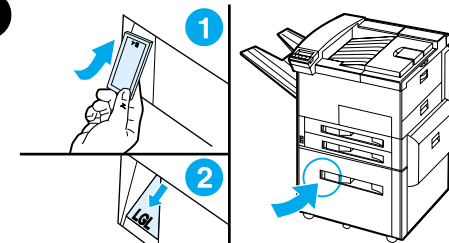

## Selecting the Output Bin

The printer has several output locations: the Standard Output Bin, the Face-up Bin, and the optional output devices.



**Note** For more information on an optional HP output device, see the user guide that came with the device.



**Continued on next page.**



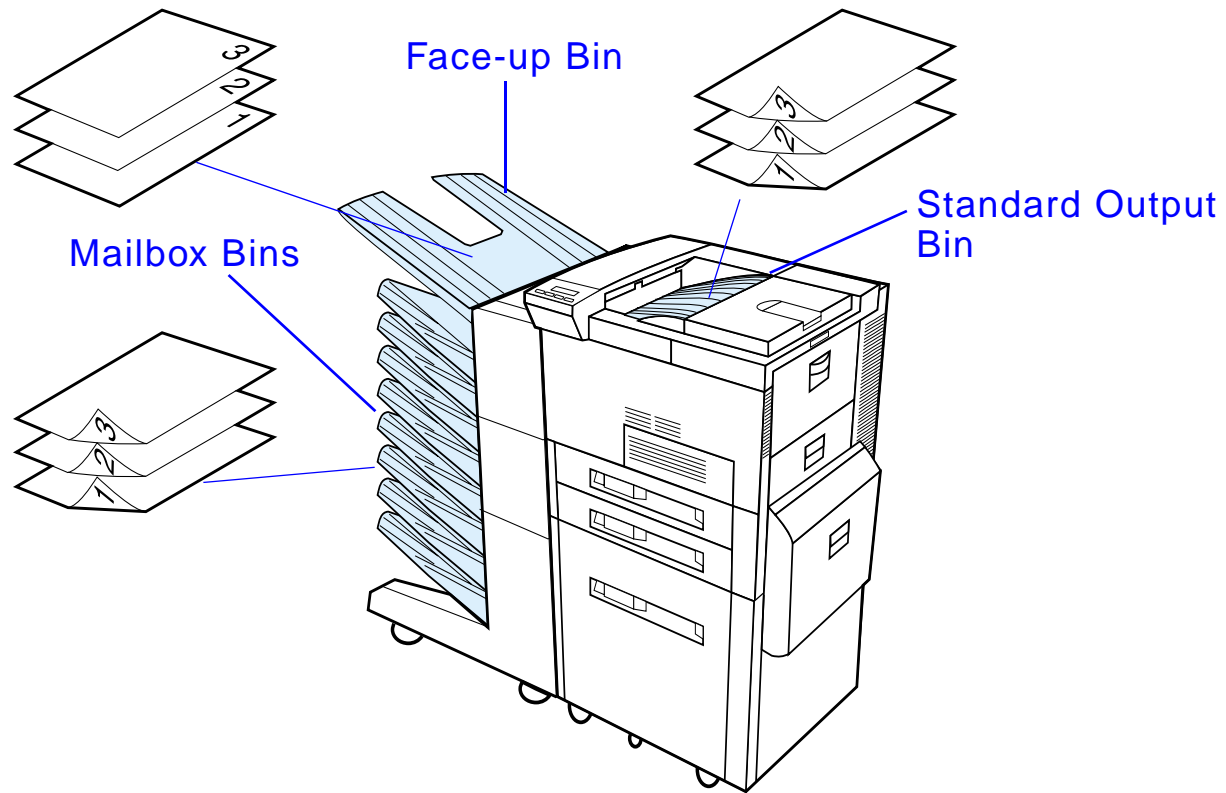

**Note** Use the Face-up Bin to print envelopes, labels, transparencies, or heavy paper.



*Selecting the Output Bin*

## *Printing to the Standard Output Bin*

The Standard Output Bin, located at the top of the printer, holds up to 500 sheets of paper in the correct order as they exit the printer. A sensor causes the printer to stop when the paper bin is full. Printing continues when you empty or reduce the amount of paper in the bin. The Standard Output Bin is the factory default bin.



## *Adjusting the Paper Stop*

The paper stop, illustrated below, is located near the Standard Output Bin. It can be adjusted to help paper lay flat as it exits the printer. The paper stop does not have to be raised for Letter or A4 size paper. Note that the printer jams if the paper stop is set to a smaller size of paper than is being printed.

- 1 Pull the left side of the paper stop up until the stop is in an upright position.
- 2 Slide the paper stop to the mark indicating the largest paper size to be printed.

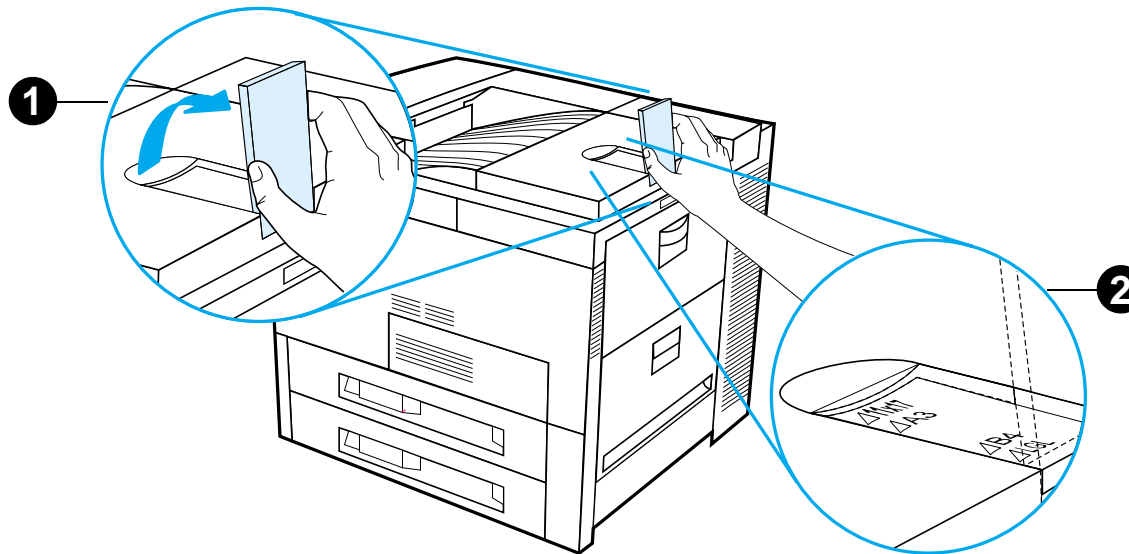



## Printing to the Face-up Bin

The Face-up Bin, located on the upper left side of the printer, holds up to 100 sheets of paper face up (reverse-order) as they exit the printer. This bin is mainly used for special paper types, such as labels, envelopes, or transparencies, that cannot tolerate the curved paper path of the Standard Output Bin. This output bin does not sense when the bin is full.

You can select an output bin through your software application, printer driver, or from the printer control panel.



---

**Note**

Settings in the printer driver and software application override control panel settings. (Software application settings override printer driver settings.)

---



## Printing to a Mailbox

Each mailbox comes with a face-up bin which replaces the Face-up Bin of the printer. The following Mailboxes are available for the printer:

- 7-bin Tabletop Mailbox (each bin holds up to 120 sheets of paper)
- 8-bin Mailbox (each bin holds up to 250 sheets of paper)
- 5-bin Mailbox with Stapler (each bin holds up to 250 sheets of paper)

These mailboxes attach to the left side of the printer. They can work in one of the following operating modes:



---

**Mailbox**

Each bin can be addressed individually as the output destination and can have a name assigned to it by the network or printer administrator.

**Collator**

In this mode, the device automatically separates mopies. Each mopy is delivered in consecutive bins, starting from the top bin. In this case, one job contains several mopies.

**Continued on next page.**



---

**Job Separator**

Print jobs are automatically sent one job per bin to the first empty bin beginning at the top bin. Non-empty bins are skipped. If all bins have paper, the job will be sent to the first non-full bin starting at the top. If a bin becomes full, the system will stop until paper is removed from that bin. Delivery then resumes in the same bin.



**Stacker**

This mode stacks the printed output from the lowest bin to the top, regardless of job boundaries. This mode of operation takes advantage of the total capacity of the mailbox bins. The device is seen by the software as one logical bin.



## ***How to Configure the Operating Modes***

The network or printer administrator chooses the mode of operation through the control panel or through an HP network configuration utility, such as HP Web JetAdmin or HP LaserJet Utility. You will need to set up your printer driver to reflect the mode chosen by the administrator.

### **Bidirectional Environment**

The printer automatically selects the mode established by the network administrator.

### **Nonbidirectional Environment**

The driver setting must match the printer mailbox mode. The method for changing the mode varies with driver and by operating system. See your driver's online help.

The printer control panel will display different messages depending on the mailbox used and which mode you are using. See the printer software help for more information.



## *Mailbox Mode*

**Note**

To customize the name for an output bin in the control panel, use HP Web JetAdmin software. See HP's web site at <http://www.hp.com/go/webjetadmin> for more information on HP Web JetAdmin.



	<b>In Mailbox Mode, if the Control Panel setting is:</b>	<b>Then the physical location is:</b>
<b>5-bin Mailbox with Stapler</b>	FACE UP BIN	Face-up Bin
	OPTIONAL BIN 1 through 5	Mailbox 1-5
	OPTIONAL BIN 6	Stapler Bin
<b>7-bin Tabletop Mailbox</b>	FACE UP BIN	Face-up Bin
	OPTIONAL BIN 1 through 7	Mailbox 1-7
<b>8-bin Mailbox</b>	FACE UP BIN	Face-up Bin
	OPTIONAL BIN 1 through 8	Mailbox 1-8



### *Selecting the Output Bin*

## *Job Separation, Collator, and Stacking Modes*



**Note**

To customize the name for an output bin in the control panel, use HP Web JetAdmin software. See HP's web site at <http://www.hp.com/go/webjetadmin> for more information on HP Web JetAdmin.



	<b>In Job Separation, Collator, and Stacking Modes, if the Control Panel setting is:</b>	<b>Then the physical location is:</b>
<b>5-bin Mailbox with Stapler</b>	FACE UP BIN	Face-up Bin
	OPTIONAL BIN 1	Mailbox 1-5
	OPTIONAL BIN 2	Stapler Bin
<b>7-bin Tabletop Mailbox</b>	FACE UP BIN	Face-up Bin
	OPTIONAL BIN 1	Mailbox 1-7

Continued on next page.





	In Job Separation, Collator, and Stacking Modes, if the Control Panel setting is:	Then the physical location is:
<b>8-bin Mailbox</b>	FACE UP BIN	Face-up Bin
	OPTIONAL BIN 1	Mailbox 1-8



**Note** For the types of paper the printer supports, see page [397](#)). Envelopes, labels, and transparencies should only be sent to the Face-up Bin.



The stapler is located on the left side of the 5-bin Mailbox with Stapler. The stapler can staple jobs of 2 to 20 sheets up to 28 lb paper. The stapler bin can hold a maximum of 350 sheets. Only jobs sent to the stapler bin will be stapled.

### *Selecting a Mailbox through the Software*

You can select mailboxes through your software application, printer driver, or from the printer control panel. Otherwise, follow the instructions below for setting the overall default printer output bin selection. Where and how you make selections depends on your software application or associated printer driver. (Some options may only be available through the printer driver.)



#### *Selecting the Output Bin*

## *Selecting Mailboxes from the Control Panel*

- 1 Press **MENU** repeatedly until PAPER HANDLING MENU appears.
- 2 Press **ITEM** repeatedly until PAPER DEST= STANDARD OUTBIN \* appears.
- 3 Press **+** repeatedly until PAPER DEST= OPTIONAL BIN x appears. The x represents a number that varies depending upon the mailbox selected and the operating mode used. Your network administrator may have changed these names.
- 4 Press **SELECT** to save your choice. An asterisk (\*) appears next to your selection.





## Using the Stapler

**Note** For more information on the 3000-sheet Stapler/Stacker or any other stapling devices, see the user guide that came with the device.



### Loading Staple Cartridges (5-bin Mailbox with Stapler)

- 1 Turn off the printer and remove the Face-up Bin.
- 2 Open the stapler unit cover.
- 3 Squeeze the staple cartridge tabs together and pull the empty staple cartridge out.

Continued on next page.

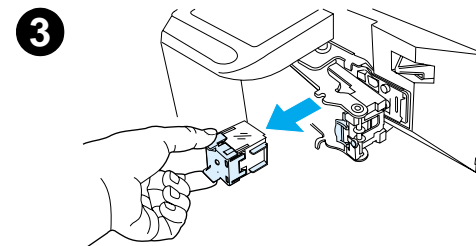
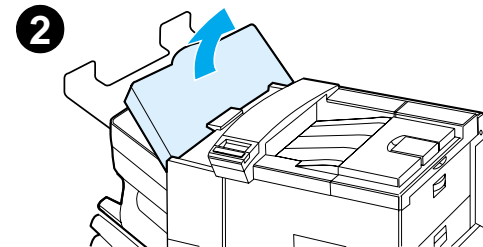
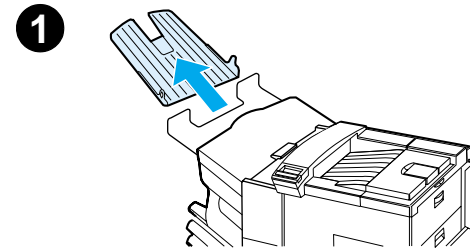

- 4 Remove the plastic shipping clip from the new staple cartridge. Insert the new staple cartridge so that it snaps into place.
- 5 Close the stapler unit cover, replace the Face-up Bin, and turn the printer on.

---

**Note**

If the printer runs completely out of staples or a staple jam requires that you remove all the staples in the path, up to six copies may not be stapled.

---

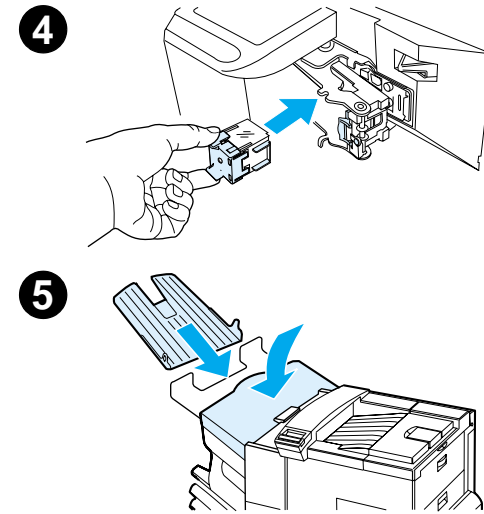

## *Stapling Documents (5-bin Mailbox with Stapler)*

The stapler can staple documents of 2 to a maximum of 20 pages on 16 to 28 lb paper, Letter, and A4 size only. The stapler should not be set as the default output bin. If your job to be stapled is only one sheet or if it is greater than 20 sheets, the printer will print your job to the bin, but it will not be stapled. For example, if your print job is 30 sheets, after 21 sheets are printed, these 21 sheets will be sent to the stapler bin (unstapled). The other 9 will be printed and delivered to the stapler bin (unstapled). The stapler bin can hold up to 350 stapled sheets. To have your job stapled, send it to `OPTIONAL BIN x`. See pages [109](#) and [110](#) to choose the appropriate bin according to the mode you are using.



## *Selecting the Stapler through the Software*

You can select the stapler through your software application or printer driver. This is the recommended method for stapling. If you are unable to designate the paper destination in your software or printer driver, follow the instructions below for setting the overall default printer output bin selection. Where and how you make selections depends on your software application or associated printer driver. (Some options may only be available through the printer driver. See page [66](#) for more information on accessing the printer driver.)



---

**Note**

Settings in the printer driver and software application override control panel settings. (Software application settings override printer driver settings.)

---



## *Selecting the Stapler from the Control Panel*

If your software does not support stapling, set it using the directions below.

- 1 Press **MENU** repeatedly until PAPER HANDLING MENU appears.
- 2 Press **ITEM** repeatedly until PAPER DEST= STANDARD OUTBIN \* appears.
- 3 Press **+** repeatedly until PAPER DEST= OPTIONAL BIN 6 appears. (See pages [109](#) and [110](#) to choose the appropriate bin according to the mode you are using.) Your network administrator may have changed the name of this bin. For example, it may be called STAPLER.
- 4 Press **SELECT** to save your choice. An asterisk (\*) appears next to your selection.



## *Printing Both Sides of Paper (Optional Duplex Printing Accessory)*

The printer can automatically print on both sides of paper with an optional duplex printing accessory (duplexer). This is called duplexing.

---

**Note**

See the documentation included with the duplexer for complete installation and setup instructions. Duplexing might require additional memory (page [467](#)).

---

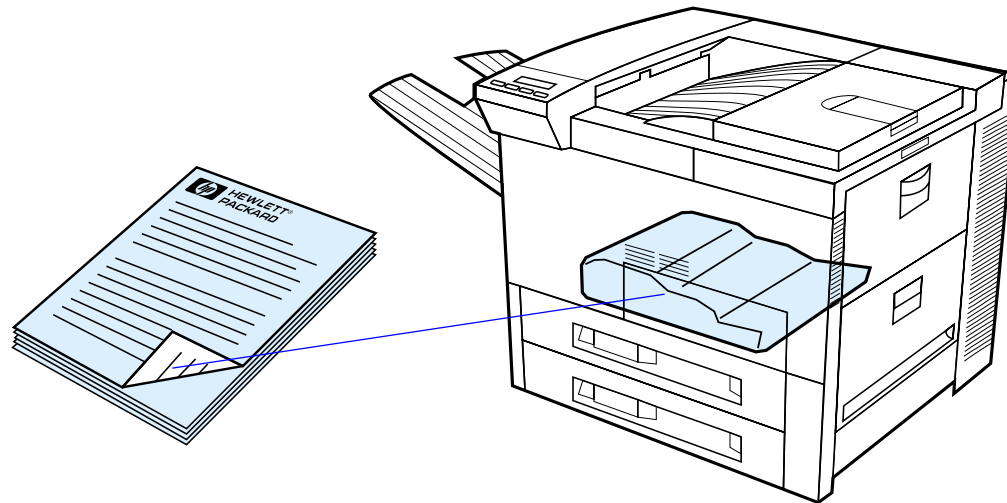

Continued on next page.



## *Guidelines for Printing Both Sides of Paper*



---

### **CAUTION**

Do not print on both sides of labels, transparencies, envelopes, custom paper, or paper heavier than 28 lb (105 g/m<sup>2</sup>). Damage to the printer and paper jamming might result.

- You might need to configure the printer driver to recognize the duplexer. (See the printer software help for details.)
- To print on both sides of paper, make the selection from the software or printer driver. (See the printer software help.)
- If the printer driver does not have this option, change the Duplex setting from the Paper Handling Menu in the printer's control panel to DUPLEX=ON. Also in the Paper Handling Menu, set Binding to long edge or short edge. (For more information, see page [121](#).)

---

### **Note**

If a Custom Paper Tray is installed, you cannot duplex standard paper sizes from Tray 1.



## ***Paper Orientation for Printing Both Sides of Paper***

The duplexer prints the second side of the paper first, so paper such as letterhead and preprinted paper needs to be oriented as shown.

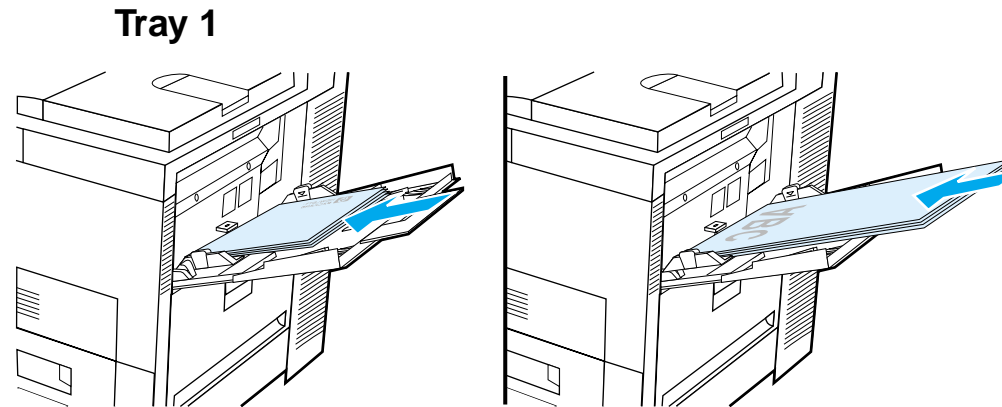

- Load letter and A4 paper with the front side down and the top, short edge toward the rear of the printer.
- Load other sizes of paper with the front side down and the top, short edge toward the printer.

**Continued on next page.**



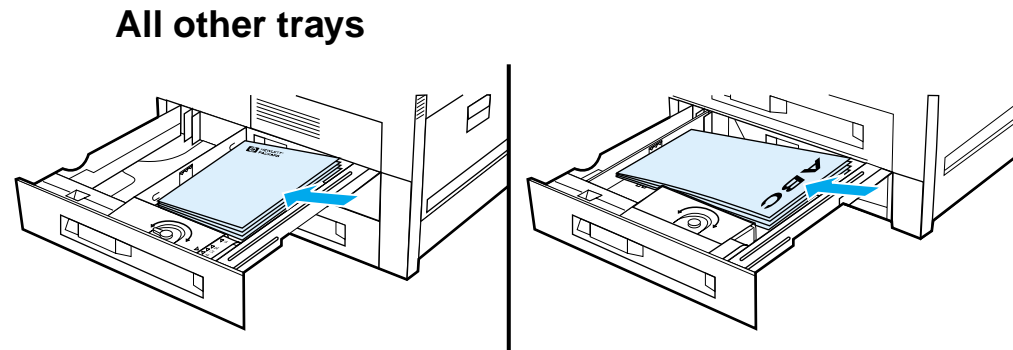

- Load letter and A4 paper with the front side up and the top, short edge toward the rear of the tray.
- Load other sizes with the front side up and the top, short edge toward the right of the tray.





### Layout Options for Printing Both Sides of Paper

The four print orientation options are shown below. These options can be selected from the printer driver or from the printer's control panel (set BINDING from the Paper Handling Menu and ORIENTATION from the Printing Menu).



**Note**

The terminology for the binding edge in the driver may be different.

**Printing left-to-right**

2. Long-edge landscape

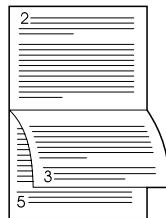

1. Long-edge portrait (default)

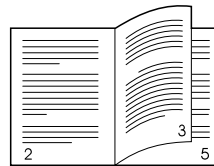

4. Short-edge landscape

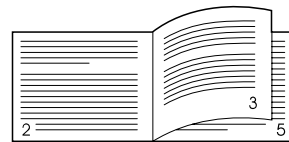

3. Short-edge portrait



Continued on next page.





**Printing  
right-to-left**

2. Long-edge  
landscape

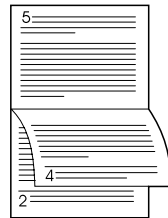

1. Long-edge  
portrait (default)

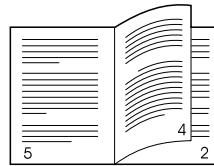

3. Short-edge  
portrait

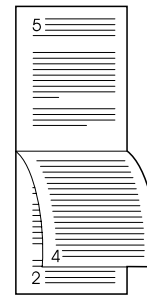

4. Short-edge  
landscape

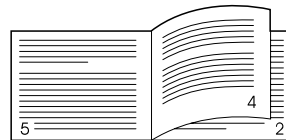

## Printing Envelopes



### Feeding Envelopes Automatically (Optional Envelope Feeder)



With the optional envelope feeder, the printer will automatically feed up to 100 envelopes. (For supported envelope sizes, see page [406](#).) To print envelopes without an envelope feeder, see page [130](#).



---

**Note** See the documentation included with the envelope feeder for complete installation and setup instructions.

---

You might need to configure the printer driver to recognize the envelope feeder. See the printer software help for details.

**Continued on next page.**



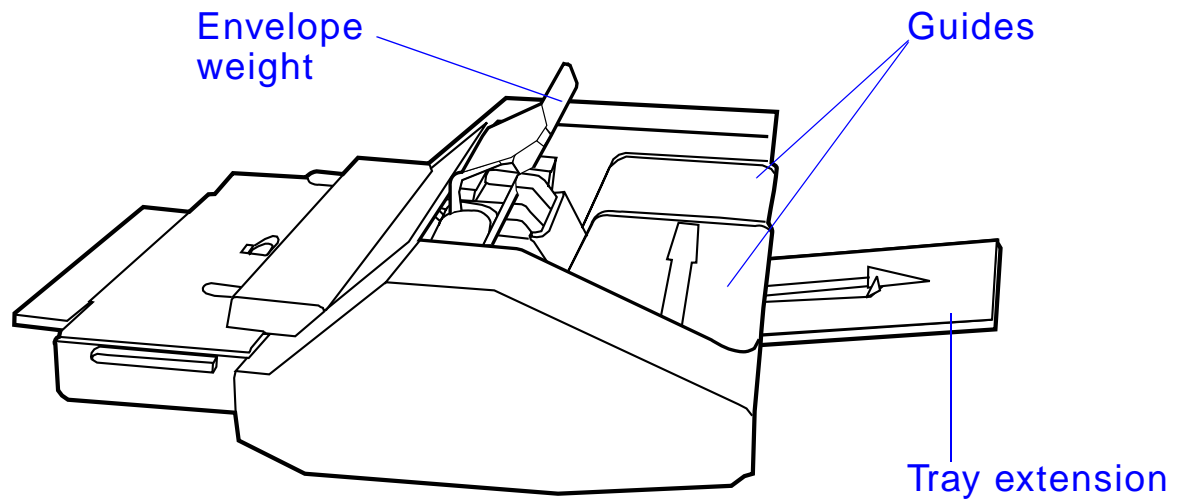

Continued on next page.



## Inserting the Envelope Feeder

- 1 Open Tray 1 and remove the cover over the opening for the envelope feeder.
- 2 Locate the pins on the envelope feeder and the corresponding holes on the printer.
- 3 Align the envelope feeder with the corresponding printer rails.
- 4 Slide the envelope feeder into the printer until it locks into place.

Continued on next page.

1

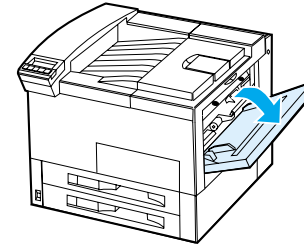

2

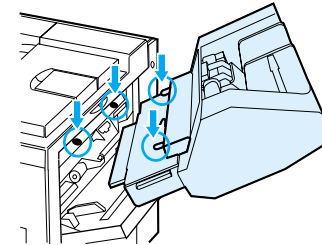

3

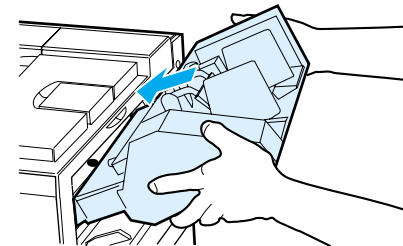

4

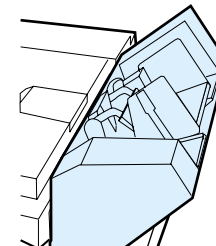

## Loading Envelopes into the Envelope Feeder

---

### Note

Print only envelopes approved for use in the printer (page [406](#)).

---

- 1 Pull out the envelope tray extender. The tray extender will help reduce jams.
- 2 To adjust the width guide to the size of the envelopes to be used, push the tab on the left guide.
- 3 Lift the envelope weight lever, and insert the envelopes up to the fill mark.

**Continued on next page.**

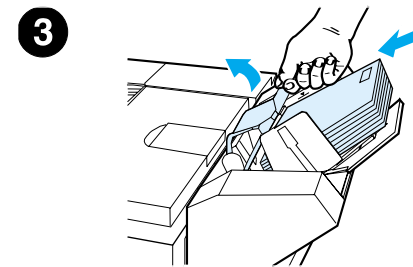
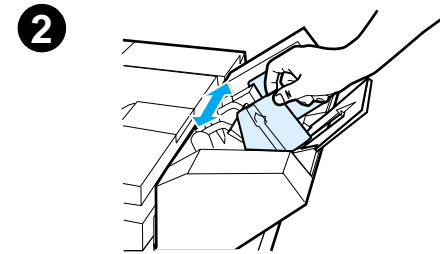
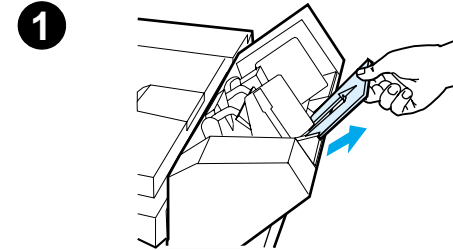

- 4 Lower the lever. The envelopes should be angled as shown (A). Do not angle them the opposite direction (B).

---

**Note**

Select the envelope size from the software application (if the setting is available), the printer driver, or the Paper Handling Menu in the printer's control panel (page [427](#)). To print by type and size of paper, see page [157](#).

---

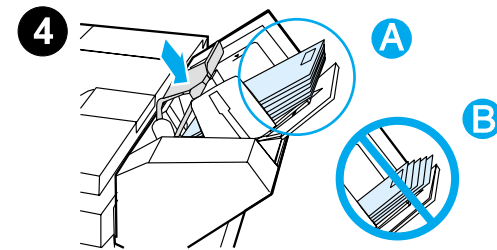

## Changing Fuser Levers for Printing Envelopes

---

### Note

Once you have used this method to print envelopes, return the fuser levers to the down position for standard paper (media) types.

---

- 1 Open the left door. (If an optional output device is installed, first push it away from the printer to access the left door.)

---

### WARNING!

Avoid touching the adjacent fusing area. It may be HOT.

---

- 2 Locate and lift up the two “T” shaped levers as shown in figure 2.

Continued on next page.

1

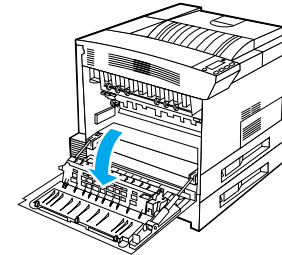

2

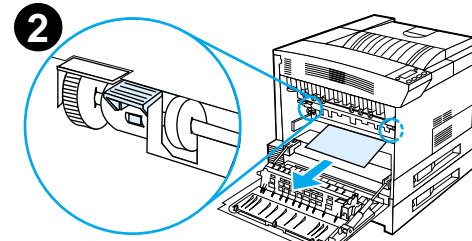



3 Close the left door.

4 Ensure that the Face-up Bin is selected when printing envelopes.

When you are done printing on envelopes, make sure you return the fuser levers to the down position.

---

**CAUTION**

Failure to return levers in the down position for standard paper types may result in poor print quality.

---

3

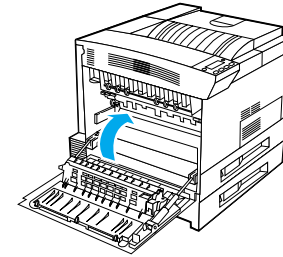

## *Printing Envelopes from Tray 1*

With the optional envelope feeder, the printer will automatically feed up to 100 envelopes. To order an envelope feeder, see page [42](#). To print with the envelope feeder, see page [123](#).

Many types of envelopes can be printed from Tray 1. (Up to 10 can be stacked in the tray.) Printing performance depends on the construction of the envelope. Always test a few sample envelopes before purchasing a large quantity.

Set margins at least 0.6 inch (15 mm) from the edge of the envelope.

**Continued on next page.**



**CAUTION**

Envelopes with clasps, snaps, windows, coated linings, exposed self-stick adhesives, or other synthetic materials can severely damage the printer.

To avoid jamming and possible printer damage, never try to print on both sides of an envelope.

Before you load envelopes, make sure they are flat and not damaged or stuck together. Do not use envelopes with pressure-sensitive adhesive. (For envelope specifications, see page [406](#).)



## Loading Envelopes in Tray 1

- 1 Open Tray 1.
- 2 If necessary, pull out the tray extension for the envelope size you are printing.
- 3 Place up to ten envelopes between the paper width guides, face up.
- 4 Slide the paper width guides until they lightly touch both sides of the envelope stack without bending it.

---

### Note

Paper heavier than 28 lb (105 g/m<sup>2</sup>) should be printed from Tray 1 to the Face-up Bin to avoid curl.

If Tray 1 is in CASSETTE mode, the printer Attention light will flash. Press - **VALUE +** to change the size to match the paper size in Tray 1, and press **SELECT**.

The fuser lever should be changed for printing envelopes (see page [128](#)).

---

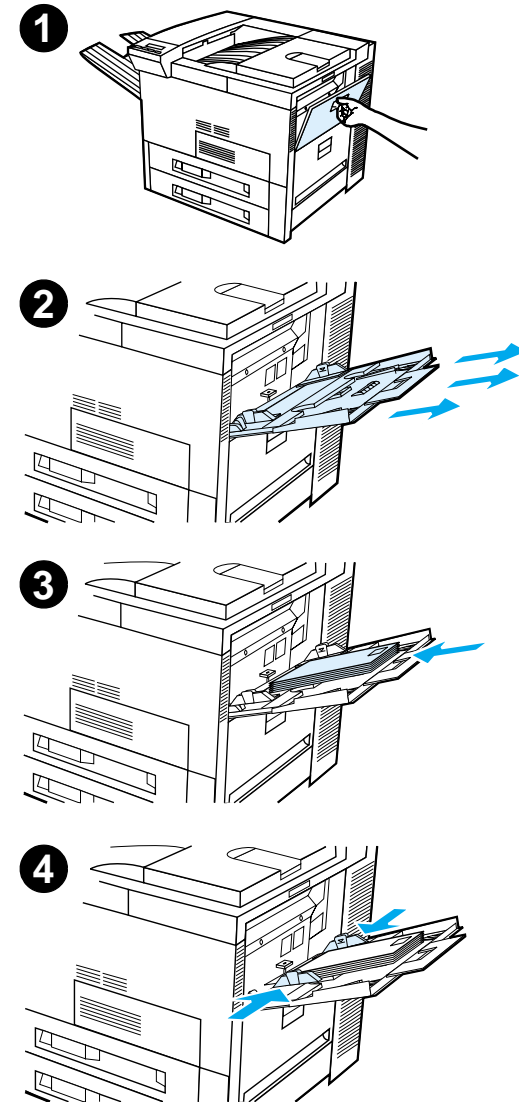

## Printing Envelopes from Your Software Application

- 1 Load envelopes into Tray 1 or the optional envelope feeder, if installed.
- 2 Specify Tray 1, Automatic, or select the paper source by type in your software application, and set the envelope size and type to the appropriate envelope size (page [406](#)).
- 3 If your software does not automatically format an envelope, specify Landscape for page orientation in your application.



**CAUTION** To avoid a printer jam, do not remove or insert an envelope once you begin printing.

For best print quality, use the table on page [408](#) to set margins for a return and mailing address. It gives you typical address margins for a Commercial #10 or DL envelope. Avoid printing over the area where an envelope's three back flaps meet.

**Note** If you print on an envelope and send it to a mailbox, the envelope will go to the mailbox Face-up Bin.



## Printing Special Paper



### Printing Letterhead, Preprinted Paper, or Prepunched Paper



Special paper includes letterhead, envelopes, labels, transparencies, full-bleed images, postcards, custom-size, and heavy paper.

When printing letterhead or preprinted paper, it is important to load the trays with the correct orientation.



When printing with prepunched paper (letter or A4 size), load the paper with the holes toward the right side of the printer for all trays except Tray 1. If using Tray 1, load the paper with the holes toward the left side of the printer. When printing on both sides of prepunched paper, you must select prepunched paper as the paper type in the Paper Handling menu from the control panel and select prepunched paper from your printer driver.

---

**Note** Stapling devices do not support proper stapling of duplexed, prepunched paper.

---



## *Printing Labels*

Use only labels recommended for use in laser printers. Make sure that labels meet the specifications for the input tray you use ([page 403](#)).

Do:

- Print a stack of 50 labels from Tray 1.
- Load labels with the side-to-be-printed facing up and the top, short edge toward the back, if they are letter or A4 size. For other sizes, load labels with the short edge toward the printer.
- Use the Face-up Bin for printing labels.

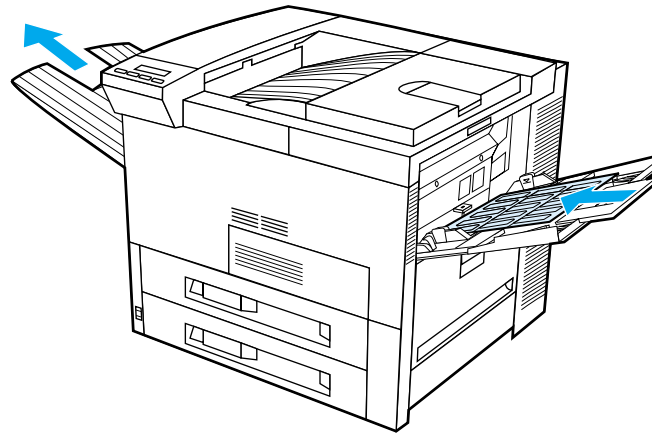

**Continued on next page.**



**CAUTION** Failure to follow these instructions can damage the printer.



Do not:

- Load Tray 1 to capacity because labels are heavier than paper.
- Use labels that are separating from the backing sheet, wrinkled, or damaged in any way.
- Use labels that have the backing sheet exposed. (Labels must cover the entire backing sheet with no exposed spaces.)
- Feed a sheet of labels through the printer more than once. The adhesive backing is designed for only one pass through the printer.
- Print on both sides of labels.
- Send labels to any output destination except the Face-up Bin.





## Printing Transparencies

Overhead transparencies used in HP LaserJet printers must be able to withstand the 392° F (200° C) temperature encountered in the printer's fusing process.

Use only transparencies recommended for use in laser printers. Because transparencies tend to stick to each other, remove each transparency from the output bin before printing the next one.

Use the Face-up Bin for printing transparencies.

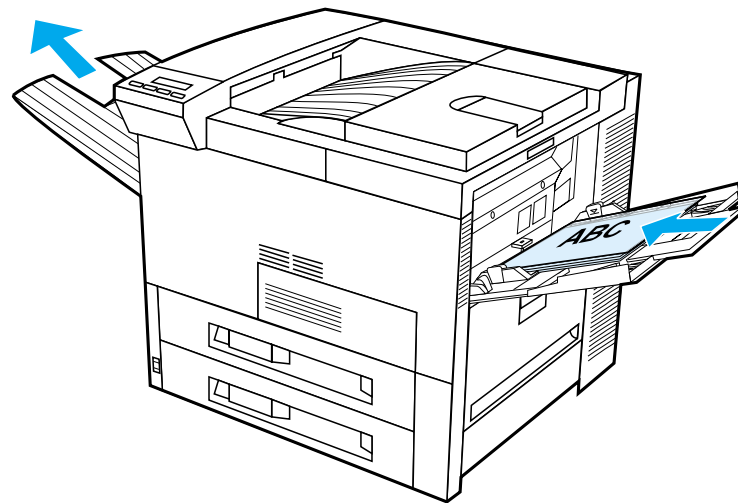

Continued on next page.



**CAUTION**

Do not print on both sides of labels, transparencies, envelopes, custom paper, or paper heavier than 28 lb (105 g/m<sup>2</sup>). Damage to the printer and paper jamming might result.



## *Custom-size Paper in Tray 1*

You can print on custom-size paper from Tray 1. For paper specifications, see page [392](#).

### *Printing on the Smallest-Sized Paper*

If you are using the printer driver to set the paper size, select the paper tab, then set the paper size under the **Custom** button.

- 1 In your software application, select **Tray 1** for the paper source and select either **Custom** or the name assigned to the custom-size paper in the driver for the paper size.

**Continued on next page.**

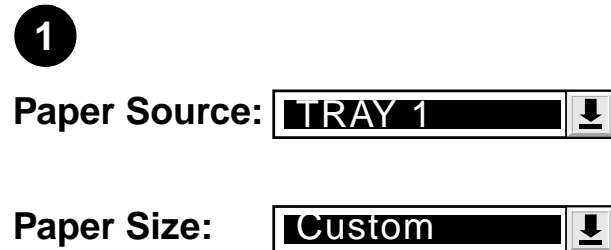

- 2 Print custom-size paper from Tray 1. See [Loading Tray 1](#) on page [89](#).
- 3 The edge of the paper feeding into the printer must be at least 3.9 inches (98 mm) wide to allow rollers inside the printer to grab the paper. Measuring from the leading edge to the trailing edge of the paper, the length must be at least 7.5 inches (190 mm).

---

**Note**

For more information on paper specifications, see page [392](#).

---

### *Printing Bleeds*

Since the printer has the ability to print on specially cut paper up to 11.7 x 17.7 inches (297 x 450 mm), you can print up to 11 x 17 inches (279 x 432 mm) bleed images with crop marks. See your software application or online help.

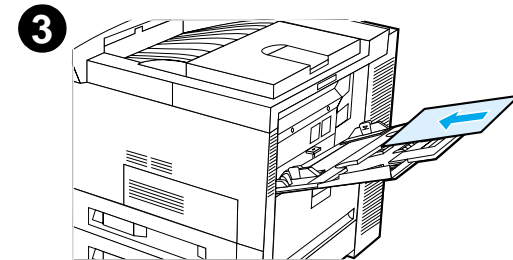
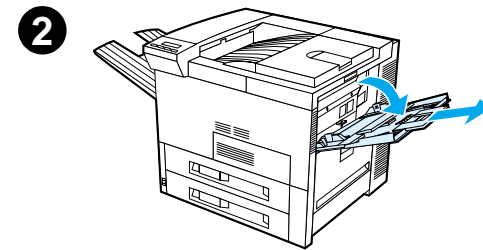

## Printing Cards, Custom-size, and Heavy Paper

Custom-size paper can be printed from Tray 1. For paper specifications, see [Paper Specifications](#) starting on page [390](#).



---

### Note

The printer's control panel can be set for one custom size at a time. Do not load more than one size of custom paper into the printer.



### Guidelines for Printing Custom-size Paper

- Do not attempt to print on paper smaller than 3.9 inches (98 mm) wide or 7.5 inches (191 mm) long.
- Two-sided printing of custom-size paper is not supported on the optional duplex printing accessory.



## ***Setting Custom Paper Sizes***

When custom paper is loaded, size settings need to be selected from the software application (the preferred method), the printer driver, or from the printer's control panel. The size settings defined for custom-size paper applies to all custom paper trays installed on the printer.



**Note**

Only one custom paper size is recognized by the printer at one time. Settings in the printer driver and software application override control panel settings. (Software application settings override printer driver settings.)

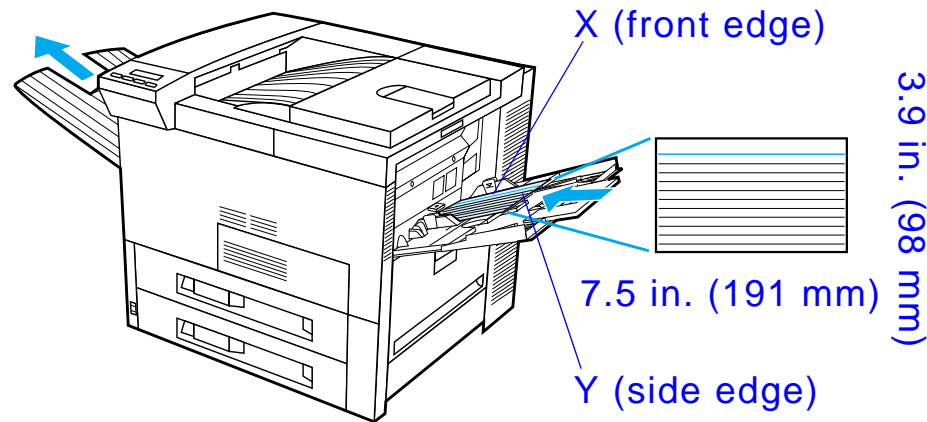

**Continued on next page.**



If the settings are not available from the software, set the custom paper size from the control panel:

- 1 From the Printing Menu set `CONFIGURE CUSTOM PAPER=YES`.
- 2 From the Printing Menu, select inches or millimeters as the unit of measurement.
- 3 From the Printing Menu, set the X dimension (the front edge of the paper) as shown in the illustration above. X can be from 3.9 to 11.7 inches (from 98 to 297 mm) for Tray 1. Set the Y dimension (the side edge of the paper) as shown in the illustration above. Y can be from 7.5 to 17.7 inches (from 191 to 450 mm) for Tray 1.
- 4 If custom paper is loaded into Tray 1 and `TRAY 1 MODE=CASSETTE`, then set `TRAY 1 SIZE=CUSTOM` from the Paper Handling Menu in the printer's control panel. See [Customizing Tray 1 Operation](#) on page [154](#).
- 5 In the software, select **Custom** or the name assigned to the custom-size paper in the driver as the paper size.

For example, if the custom paper is 8 x 10 inches (203 x 254 mm), set X=8 inches and Y=10 inches (X=203 millimeters and Y=254 millimeters).



# 3 *Advanced Printing Tasks*



## *Overview*

This chapter introduces some **advanced printing tasks** to help you take full advantage of the printer's features.

- [Using Features in the Printer Driver](#)
- [Different First Page](#)
- [Blank Back Page](#)
- [Customizing Tray 1 Operation](#)
- [Printing by Type and Size of Paper](#)
- [Changing the Variable Fuser Mode](#)
- [Loading Custom-size Paper](#)

**Continued on next page.**





- [Job Retention](#)
  - ◆ [Quick Copying a Job](#)
  - ◆ [Proofing and Holding a Job](#)
  - ◆ [Printing a Private Job](#)
  - ◆ [Storing a Print Job](#)
- [Printing with the Optional HP Fast InfraRed Connect](#)
- [Edge-to-Edge Printing](#)
- [Duplex Registration](#)



## *Using Features in the Printer Driver*

When you print from a software application, many of the printer's features are available from the printer driver. To access Windows printer drivers, see page [75](#).



---

**Note** Settings in the printer driver and software application override control panel settings. (Software application settings override printer driver settings.)

---



### *Printer Collation*

The Printer Collation feature allows multiple original prints (mopying) that provides you the following advantages:

- Reduces network traffic
- Faster return to application
- All documents are original

**Continued on next page.**



## ***RIP ONCE***

RIP ONCE allows the print job to be processed one time at the printer. The formatted print job can then be printed multiple times without pausing to process the print job again. This feature is normally active.



## ***Saving Printer Setup Information***

Printer drivers allow you to save the printer settings you use most often as the default settings. For example, the driver might be set to print on letter size paper, portrait orientation, with automatic tray selection (from the first available tray).



Windows printer drivers will allow you to save printer settings for multiple kinds of print jobs. Saved settings are called Quick Sets. For example, you might want to create a Quick Set for envelopes or for printing the first page of a document on letterhead.



## ***New Printer Driver Features***

Look for **Quick Sets**, **Scale to Fit** (any page size to any page size), and **Booklet Printing** options in the Windows printer driver, or see the printer driver help for more information.

**Continued on next page.**



## ***Printing with a Watermark***

A watermark is a notice, such as “Top Secret,” printed in the background of each page in a document. Check the driver for available options.

For Macintosh, you may be able to select “Custom” and specify the text you choose depending on your driver version.



**Note**

Watermarks for Macintosh are not supported in Traditional Chinese, Simplified Chinese, Korean, Japanese, Czech, Russian, and Turkish.



## *Different First Page*

- 1 For Windows, select “Use different paper for first page” in the paper tab of your printer driver. Choose Tray 1 (or Manual Feed) for the first page and one of the other trays for the remaining pages. Place the paper for the first page in Tray 1. (For manual feed, place paper in Tray 1 after the job is sent to the printer and the printer requests paper.) Place the paper with the side-to-be-printed up, the top of the page facing the rear of the printer, and the long edge leading into the printer.

For Macintosh, select “First from” and “Remaining from” in the print dialog box.

---

### **Note**

Where and how you make selections depends on your software application or associated printer driver. (Some options may only be available through the printer driver.)

---

**Continued on next page.**

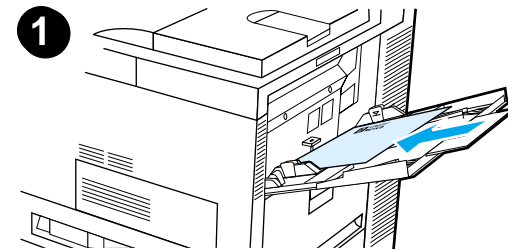

- 2 Load the paper for the remaining pages of the document into another tray. You may select the first and remaining pages by type of paper. For more information, see [Printing by Type and Size of Paper](#) on page [157](#).

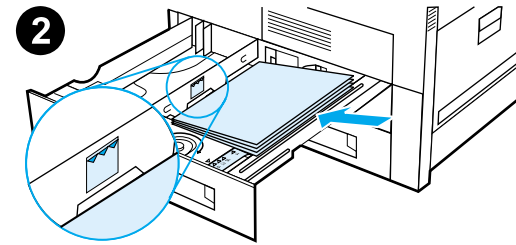

## ***Blank Back Page***

This option will allow you to add blank pages to the back of a print job.

For Windows, select “Use different paper for first page” in the paper tab of your printer driver and then choose “Back Page.” You can then select the paper source you wish to use for your back page, or to turn the feature off select “No back page.”



## *Printing Multiple Pages on One Sheet of Paper*

You can print more than one page on a single sheet of paper. This feature is available in some printer drivers and provides a cost-effective way to print draft pages.

To print more than one page on a sheet of paper, look for a Layout or Pages Per Sheet option in the printer driver. (This is sometimes called 2-up, 4-up, or n-up printing.)

### **Printing left-to-right**

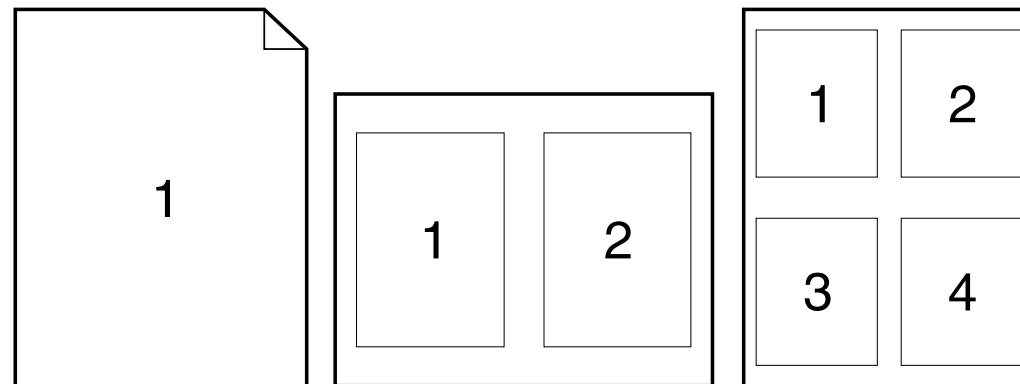

Continued on next page.





Printing  
right-to-left

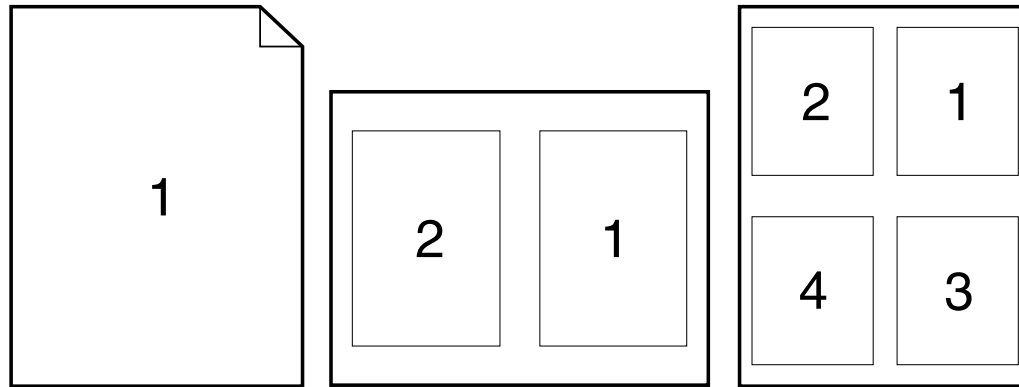

## *Customizing Tray 1 Operation*

Customize Tray 1 to fit your printing needs.

The printer can be set to print from Tray 1 as long as it is loaded or to print only from Tray 1 if the type of paper loaded is specifically requested. Set `TRAY 1 MODE=FIRST` or `TRAY 1 MODE=CASSETTE` from the Paper Handling Menu in the printer's control panel. (Print speed might be slightly slower when printing from Tray 1 when `TRAY 1 MODE=FIRST`.)



### *Tray 1 Mode=First*

If you do not keep paper in Tray 1 all the time or you use Tray 1 only for manually feeding paper, keep the default setting `TRAY 1 MODE=FIRST` in the Paper Handling Menu.

- `TRAY 1 MODE=FIRST` means that the printer usually pulls paper from Tray 1 first unless it is empty or closed.
- You can still choose paper from other trays by specifically choosing another tray in the printer driver or from your software application.



## *Tray 1 Mode=Cassette*

TRAY 1 MODE=CASSETTE means the printer treats Tray 1 like the internal trays. Instead of looking for paper in Tray 1 first, the printer pulls paper either starting from the bottom tray upward or the tray that matches type or size settings selected from the software.

- When TRAY 1 MODE=CASSETTE is set, an option appears in the Paper Handling Menu to configure **size** as well as **type** settings for Tray 1.
- Through the printer driver or from within your software application, you can select paper from any tray (including Tray 1) by type, size, or source. To print by type and size of paper, see page [157](#).



## *Manually Feeding Paper from Tray 1*

The Manual Feed feature allows you to print on special paper from Tray 1, such as envelopes or letterhead. If Manual Feed is selected, the printer will print only from Tray 1.

Select Manual Feed through the software or printer driver. Manual Feed can also be enabled from the Paper Handling Menu in the printer's control panel.

---

### **Note**

When Manual Feed is selected, if `TRAY 1 MODE=FIRST` the printer automatically prints (if paper is in the tray). If `TRAY 1 MODE=CASSETTE` the printer prompts to load Tray 1 whether or not Tray 1 is loaded. This enables you to load different paper if necessary. Press **Go** to print from Tray 1.

---



## *Printing by Type and Size of Paper*

You can configure the printer to select paper by **type** (such as plain or letterhead) and **size** (such as letter or A4), as opposed to **source** (a paper tray).



### *Benefits of Printing by Type and Size of Paper*

If you frequently use several different kinds of paper, once trays are set up correctly, you do not have to check which paper is loaded in each tray before you print. This is especially helpful when the printer is shared and more than one person loads or removes paper.

Printing by type and size of paper is a way to be sure that print jobs always print on the desired paper. (Some printers have a feature that “locks out” trays to prevent printing on the wrong paper. Printing by type and size of paper eliminates the need to lock out trays.)

**To print by type and size of paper, do the following:**

- 1 Be sure to adjust and load the trays correctly. (See the sections on loading paper, starting on page [89](#).)

**Continued on next page.**



- 2 From the Paper Handling Menu in the printer's control panel, select the paper **type** for each tray. If you are unsure what type you are loading (such as bond or recycled), check the label on the package of paper. For supported types, see page [397](#).
- 3 Select the paper **size** settings from the control panel.
  - ◆ **Tray 1:** If the printer has been set to TRAY 1 MODE=CASSETTE from the Paper Handling Menu, also set the paper size from the Paper Handling Menu. If custom paper is loaded, set the size of custom paper from the Printing Menu to match the paper loaded in Tray 1. To print custom-size paper, see page [139](#).
  - ◆ **Other trays:** Paper size settings are adjusted when paper is properly loaded into the printer. (See the sections on loading paper, starting on page [89](#).)
- 4 From the software or printer driver, select the desired type and size of paper.



**Continued on next page.**



---

**Note**

The type and size settings can also be configured from HP Web JetAdmin for networked printers. See the printer software help.

To print by type and size, it might be necessary to unload or close Tray 1 or set `TRAY 1 MODE=CASSETTE` from the Paper Handling Menu in the printer's control panel. For more information, see page [427](#).

Settings in the printer driver and software application override control panel settings. (Software application settings override printer driver settings.)

---



## *Changing the Variable Fuser Mode*

The variable fuser mode specifies the temperature and printing speed for a specific type of paper. The user can change the variable fuser mode to improve the print quality for paper that is having problems (such as heavy, light, or rough media) even though the paper technically meets the specifications provided on page [392](#).

The variable fuser mode is associated with the paper type. To use one of the variable fuser modes, the paper type the user specifies in the driver for the job must be one of the following:

- plain
- preprinted
- letterhead
- transparencies
- prepunched
- labels
- bond
- recycled
- color
- cardstock
- rough

**Continued on next page.**





The user can change the variable fuser mode for each of these types of paper from the control panel. The following are the variable fuser modes:



---

Variable Fuser Mode	Temperature and Printing Speed for Letter and A4
---------------------	--

---

NORMAL	Normal fuser temperature setting, 32 ppm
LOW	Low fuser temperature setting, 32 ppm
HIGH1	Raises fuser temperature setting, 32 ppm
HIGH2	Raises fuser temperature setting, 24 ppm
HIGH3	Raises fuser temperature setting, 16 ppm

---



Most paper types are set to NORMAL by default. The exceptions are:

- TRANSPRNCY=LOW
- LABELS=HIGH1
- CARDSTOCK=HIGH2
- ROUGH=HIGH1

**Continued on next page.**



To change the variable fuser mode for a paper type from the control panel:

- 1 Press **MENU** repeatedly until PAPER HANDLING MENU appears.
- 2 Press **ITEM** repeatedly until CONFIGURE FUSER MODE MENU=NO appears.
- 3 Press **- VALUE +** until YES appears.
- 4 Press **SELECT** to select the option.
- 5 Press **ITEM** repeatedly until the desired paper type appears.
- 6 Press **- VALUE +** repeatedly until the desired variable fuser mode appears.
- 7 Press **SELECT** to select the variable fuser mode.
- 8 Press **GO** to exit the menu.



**CAUTION**

If you change the variable fuser mode to HIGH1, HIGH2, or HIGH3, be sure to change the variable fuser mode back to the NORMAL setting when you are done printing that job.



## *Loading Custom-size Paper*

Custom-size paper can be loaded into Tray 1 and, with the optional Custom Paper Tray accessories, into Trays 3 and 5. However, only one custom paper size can be defined in the control panel. This means that you can have several Custom Paper Trays, but you must put the same custom-size paper in all of them.

When custom-size paper is loaded into Tray 1, the printer prints at a slower speed because it picks up paper based on the maximum size of paper the printer supports. When custom-size paper is loaded in Trays 3 and 5, the printer prints at normal speed because it picks up paper based on the size defined in the control panel.

If a Custom Paper Tray is installed, you cannot print on both sides of custom-size paper.

- 1 Load the custom-size paper in Tray 1, 3, or 5. See [Loading Tray 1](#) on page 89 and [Loading Trays 2, 3, and the Optional 2 x 500-sheet Input Tray \(Trays 4 and 5\)](#) on page 93 for instructions.
- 2 On the control panel, press **MENU** repeatedly until PRINTING MENU appears.
- 3 Press **ITEM** repeatedly until CONFIGURE CUSTOM PAPER=NO appears.

**Continued on next page.**



- 4 Press - VALUE + until YES appears.
- 5 Press SELECT to save the selection.
- 6 To select the unit of measure:
  - a Press ITEM until UNIT OF MEASURE appears.
  - b Press - VALUE + repeatedly until the desired unit of measure appears.
  - c Press SELECT to save the selection.
- 7 To select the X dimension (see page [142](#) for more information about the X dimension):
  - a Press ITEM until X DIMENSION appears.
  - b Press - VALUE + repeatedly until the desired size appears.
  - c Press SELECT to save the selection.



**Continued on next page.**



- 8** To select the Y dimension (see page [142](#) for more information about the Y dimension):
  - a** Press **ITEM** until Y DIMENSION appears.
  - b** Press **- VALUE +** repeatedly until the desired size appears.
  - c** Press **SELECT** to save the selection.
- 9** Press **GO** to exit the menu.



## *Job Retention*

There are four job retention features: Quick Copy, Proof and Hold, Private Job, and Stored Job (all are available with a hard disk installed). Proof and Hold and Private Job are also available without a hard disk installed. See the following pages for more information on each of these features.

To access each of the features, first follow the steps below, then continue to the section that describes the feature you wish to use.

### **For Windows only:**

- 1 Select **Print** from the application's menu.
- 2 Click **Properties** to display the properties dialog box.
- 3 Click the **Destination** tab to display the destination options.
- 4 Click **Options** under **Destination Features** to display **Job Retention Options**.

### **For Macintosh only:**

Select **Job Retention** from the pull-down menu in the print dialog box for newer drivers. For older drivers, select **Printer Specific Options**.



## *Quick Copying a Job*

The quick copy feature prints the requested number of copies of a job and stores a copy of the job on the printer's hard disk. Additional copies of the job can be printed later. For more information about specifying the number of quick copy jobs that can be stored, see the `QUICK COPY JOBS` control panel item described on page [454](#).

**Continued on next page.**



### ***Printing Additional Copies of a Quick Copy Job***

To print additional copies of a job stored on the printer's hard disk from the control panel:

- 1 Press **MENU** repeatedly until PRIVATE/STORED JOBS MENU appears.
- 2 Press **ITEM** until your user name appears.
- 3 Press **VALUE** until the desired job name appears.
- 4 Press **SELECT** to select the job. COPIES=x appears.
- 5 Press - **VALUE** + until the desired number of copies appears.
- 6 Press **SELECT** to print the job.





## ***Deleting a Stored Quick Copy Job***

When a user sends a quick copy job, the printer overwrites any previous jobs with the same name. If there is not a quick copy job already stored under the job name and the printer needs additional space, the printer may delete other stored quick copy jobs starting with the oldest job. The default number of quick copy jobs that can be stored is 32. The number of quick copy jobs that can be stored is set from the control panel (see page [454](#)).



---

**Note**

If you turn the printer off and then back on, all quick copy, proof and hold, and private jobs are deleted.

---

A stored quick copy job can also be deleted from the control panel or from HP Web JetAdmin.

- 1 Press **MENU** repeatedly until `PRIVATE/STORED JOBS MENU` appears.
- 2 Press **ITEM** until your user name appears.
- 3 Press **VALUE** until the desired job name appears.
- 4 Press **SELECT** to select the job. `COPIES=x` appears.
- 5 Press **- VALUE** until `DELETE` appears.
- 6 Press **SELECT** to delete the job.



## *Proofing and Holding a Job*

The proof and hold feature provides a quick and easy way to print and proof one copy of a job and then print the additional copies. The job is held on the printer's hard disk or memory until the user prints the additional copies. After the additional copies are printed, the proof and hold job is deleted from the printer.



---

**Note**

The proof and hold feature also works if the printer does not have a hard disk by using the printer's available RAM memory. For moderate to heavy use of this feature, HP recommends adding a hard disk.

---

To permanently store the job and prevent the printer from deleting it when space is needed for something else, select the Stored Job option in the driver.

**Continued on next page.**



## ***Printing the Remaining Copies of a Held Job***

The user can print the remaining copies of a job held on the printer's hard disk from the control panel.

- 1 Press **MENU** repeatedly until PRIVATE/STORED JOBS MENU appears.
- 2 Press **ITEM** until your user name appears.
- 3 Press **VALUE** until the desired job name appears.
- 4 Press **SELECT** to select the job. COPIES=x appears.
- 5 Press - **VALUE** + until the desired number of copies appears.
- 6 Press **SELECT** to print the job.

**Continued on next page.**



## ***Deleting a Held Job***

When a user sends a proof and hold job, the printer overwrites any previous jobs with the same name.



---

### **Note**

If you turn the printer off and then back on, all quick copy, proof and hold, and private jobs are deleted.

---



A stored proof and hold job can also be deleted from the control panel.

- 1 Press **MENU** repeatedly until PRIVATE/STORED JOBS MENU appears.
- 2 Press **ITEM** until your user name appears.
- 3 Press - **VALUE** + until the desired job name appears.
- 4 Press **SELECT** to select the job. COPIES=x appears.
- 5 Press - **VALUE** until DELETE appears.
- 6 Press **SELECT** to delete the job.



## *Printing a Private Job*

The private printing feature lets a user specify that a job is not printed until that user releases it using a 4-digit Personal Identification Number (PIN) through the printer's control panel. The user specifies the PIN in the driver and it is sent to the printer as part of the print job.



---

### **Note**

The private printing feature also works if the printer does not have a hard disk by using the printer's available RAM memory. For moderate to heavy use of this feature, HP recommends adding a hard disk.

---

## *Specifying a Private Job*

To specify that a job is private from the driver, select the Private Job option and type a 4-digit PIN.

**Continued on next page.**



## ***Releasing a Private Job***

The user can print a private job from the control panel.

- 1 Press **MENU** repeatedly until PRIVATE/STORED JOBS MENU appears.
- 2 Press **ITEM** until your user name appears.
- 3 Press **VALUE** until the desired job name appears.
- 4 Press **SELECT**. PIN:0000 appears.
- 5 Press - **VALUE** + to change the first number of the PIN, and then press **SELECT**. An \* appears in place of the number. Repeat these steps to change the remaining three numbers of the PIN. COPIES=x appears.
- 6 Press - **VALUE** + until the desired number of copies appears.
- 7 Press **SELECT** to print the job.

**Continued on next page.**



## ***Deleting a Private Job***

When a user sends a private job, the printer overwrites any previous jobs with the same name. A private job is automatically deleted from the printer's hard disk or memory after the user releases it for printing.



---

### **Note**

---

If you turn the printer off and then back on, all quick copy, proof and hold, and private jobs are deleted.

A private job can also be deleted from the printer's control panel before it is ever printed.

- 1 Press **MENU** repeatedly until PRIVATE/STORED JOBS MENU appears.
- 2 Press **ITEM** until your user name appears.
- 3 Press **- VALUE +** until the desired job name appears.
- 4 Press **SELECT** to select the job. PIN:0000 appears.
- 5 Press **- VALUE +** to change the first number of the PIN, and then press **SELECT**. An \* appears in place of the number. Repeat these steps to change the remaining three numbers of the PIN. COPIES=x appears.

**Continued on next page.**



- 6 Press - **VALUE** until **DELETE** appears.
- 7 Press **SELECT** to delete the job.



## *Storing a Print Job*

The user can download a print job to the printer's hard disk without printing it. The user can then print the job at any time through the printer's control panel. For example, a user may want to download a personnel form, calendar, time sheet, or accounting form that other users can access and print.



To store a print job permanently on the hard disk, select the Stored Job option in the driver when printing the job.

### *Specifying a Stored Job as Private*

To specify that a stored job in the driver is private, select the Require PIN to Print option below the Stored Job option and type a 4-digit PIN.

**Continued on next page.**





## ***Printing a Stored Job***

The user can print a job stored on the printer's hard disk from the control panel.

- 1 Press **MENU** repeatedly until `PRIVATE/STORED JOBS MENU` appears.
- 2 Press **ITEM** until your user name appears.
- 3 Press **VALUE** until the desired job name appears.
- 4 (Follow this step only if printing a private job.) Press **SELECT**. `PIN:0000` appears.
- 5 (Follow this step only if printing a private job.) Press **- VALUE +** to change the first number of the PIN, and then press **SELECT**. An `*` appears in place of the number. Repeat these steps to change the remaining three numbers of the PIN. `COPIES=1` appears.
- 6 Press **- VALUE +** until the desired number of copies appears.
- 7 Press **SELECT** to print the job.

**Continued on next page.**



## ***Deleting a Stored Job***

When a user sends a stored job, the printer overwrites any previous jobs with the same name. Jobs stored on the printer's hard disk can be deleted from the control panel.

- 1 Press **MENU** repeatedly until PRIVATE/STORED JOBS MENU appears.
- 2 Press **ITEM** until your user name appears.
- 3 Press **- VALUE +** until the desired job name appears.
- 4 (Follow this step only if printing a private job.) Press **SELECT** to select the job. PIN: 0000 appears.
- 5 (Follow this step only if deleting a private job.) Press **- VALUE +** to change the first number of the PIN, and then press **SELECT**. An \* appears in place of the number. Repeat these steps to change the remaining three numbers of the PIN. COPIES=1 appears.
- 6 Press **- VALUE** until DELETE appears.
- 7 Press **SELECT** to delete the job.



## *Printing with the Optional HP Fast InfraRed Connect*

The HP Fast InfraRed Connect enables wireless printing from any IRDA-compliant portable device (such as a laptop computer) to the printer.

The printing connection is maintained by positioning the sending infrared (FIR) port within operating range. Note that the connection can be blocked by objects such as a hand, paper, direct sunlight, or any bright light shining into either FIR port.



---

**Note**

For more information, see the user guide for the HP Fast InfraRed Connect.



## *Setting Up to Print with Windows 3.1x*

---

### **Note**

When printing in Windows 3.1, go to the **Printers** icon in the Control Panel window and make sure that Use Print Manager is selected and that Fast Printing Direct to Port is not selected.

---

- 1 Make sure that the printer is in `READY` mode.
- 2 From the **Program Manager** window, select the **Main** group, and then select **Control Panel**.
- 3 From the **Printers** window, make sure that the appropriate printer is selected. If not, click **Select** and select the printer.
- 4 Click **Connect** and choose the same COM port setting as the FIR port on your portable computer.
- 5 Select the file to print.



## *Setting Up to Print with Windows 9x*

Before launching the InfraRed Driver, complete the following steps:

- 1 From the **Printers** panel, select your printer model number as your default printer.
- 2 While in the same **Printers** panel, go to **Properties/Details**, and make sure that Virtual Infrared LPT Port is selected.
- 3 Select the file to print.



## *Printing a Job*

- 1 Align your laptop computer (or other portable device equipped with an IRDA-compliant FIR window) within 2 to 3 feet (1 meter) maximum of the HP Fast InfraRed Connect. The FIR window must be at an angle of +/- 15 degrees to ensure an effective connection for printing. The following graphic illustrates the required alignment of devices necessary for printing.

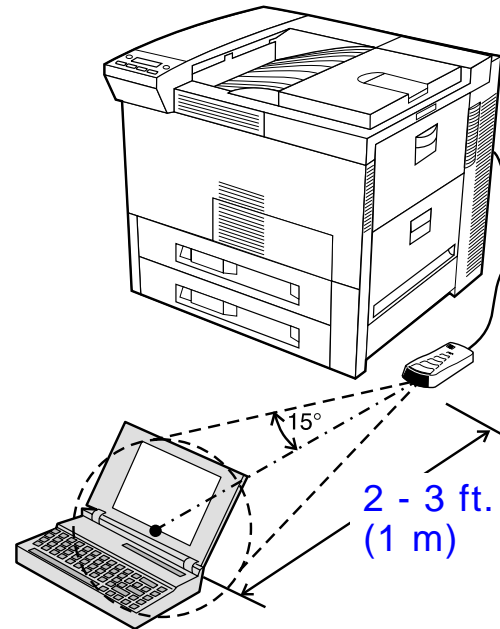

Continued on next page.

*Printing with the Optional HP Fast InfraRed Connect*



- 2 Print the job. The status indicator on the HP Fast InfraRed Connect lights up, and, after a short delay, the printer status panel displays `PROCESSING JOB`.

If the status indicator does not light up, realign the HP Fast InfraRed Connect with the FIR port on the sending device, resend the print job, and maintain the alignment of all devices. If you have to move the equipment (for example, to add paper), make sure that all devices remain within the range of operation to maintain the connection.

If the connection is interrupted before your print job is complete, the HP Fast InfraRed Connect status indicator turns off. You have up to 40 seconds to correct the interruption and continue the job. If the connection is resumed within this time, the status indicator lights up again.



---

**Note**

The connection is permanently broken if the sending port is moved out of operating range or if anything passing between the ports blocks transmission. (This block could be a hand, paper, or even direct sunlight.) Depending on the size of the job, printing with the HP Fast InfraRed Connect may be slower than printing with a cable connected directly to the parallel port.

---



## *Interrupting and Resuming Printing*

The job interrupt and resume feature lets a user temporarily stop the job that is currently printing in order to print another job. When the new job is finished printing, the interrupted job resumes printing.

A user can only interrupt jobs that are printing and collating multiple copies by connecting to the infrared (FIR) port on the printer and sending a job to the printer. The printer stops printing the current job when it reaches the end of the copy it is printing. The printer then prints the job sent over the FIR connection. When the printer is done printing that job, it resumes printing the original job with multiple copies where it left off.





## *Edge-to-Edge Printing*

This feature provides the user with the ability to print within approximately 2 millimeters of all edges of the page.

An internal-tray calibration page allows the administrator to calibrate each tray. The calibration page can be printed from each internal tray and the top tray of an external paper-handling device. The calibration page cannot be printed from the envelope feeder.

The edge-to-edge print mode is set from the printer driver or the control panel. It is most common to use the printer driver when printing individual print jobs. When set from the control panel, the edge-to-edge feature will remain in edge-to-edge print mode until turned off from the control panel or from a print job.

To print a calibration page:

- 1 Make sure that paper is loaded in the desired tray or trays and that the trays are properly inserted into the printer
- 2 Press **MENU** repeatedly until PAPER HANDLING MENU appears.
- 3 Press **ITEM** repeatedly until CONFIGURE EDGE TO EDGE=NO appears.

**Continued on next page.**



- 4 Press **VALUE** to change the value to YES.
- 5 Press **SELECT**.
- 6 Press **ITEM** repeatedly until PRINT TEST PAGE TRAY=n appears.
- 7 Press **VALUE** to choose the desired tray (ALL, 1, 2, 3, or 4).
- 8 Press **SELECT** to print the calibration page.
- 9 Follow the instructions on the calibration page to complete the calibration process.



**CAUTION**

When using edge-to-edge printing, clean the printer every time the toner cartridge is changed. See page [197](#) for cleaning instructions.



# Duplex Registration

The duplex registration feature allows precise alignment of images on the front and back of a duplexed page. Image placement varies slightly for each input tray. The alignment procedure must be performed for each tray.

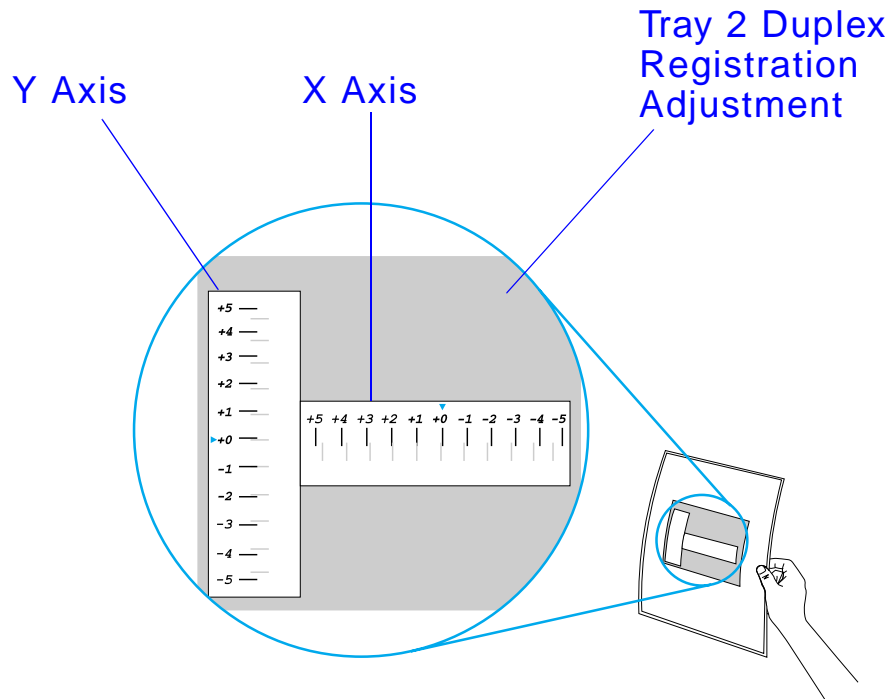

- 1 Press **MENU** until DUPLEX REGISTRATION MENU appears on the printer control panel display.

Continued on next page.



- 2 Press **ITEM** until PRINT TEST PAGE appears for the tray you want.
- 3 Press **SELECT** to print the page.
- 4 Hold the printed page up to a light source and choose the number on each axis where the lines on the front and back of the page align most accurately.
- 5 Repeat step 1.
- 6 Press **ITEM** until TRAY n X= appears and use - **VALUE** + to enter the number you selected from the test page in step 4. Press **SELECT** to save this value.
- 7 Repeat step 6 for the Y axis.
- 8 Press **ITEM** to scroll up through the duplex registration menu until PRINT TEST PAGE appears for the tray you want.
- 9 Press **SELECT** to print the page.
- 10 Repeat step 4 to verify that the lines on the front and back of the page are now properly aligned.



---

**Note** If the lines on the front and back of the page do not properly align, then repeat steps 4-9 until they are properly aligned.

---



# 4 Printer Maintenance



## Overview

This chapter explains basic printer maintenance.

- [Printer Maintenance Kit](#)
- [Managing the Toner Cartridge](#)
- [Cleaning the Printer](#)



## Printer Maintenance Kit



**Note** The Printer Maintenance Kit is a consumable and is not covered under warranty.



To ensure optimum print quality, the printer will prompt you to perform printer maintenance every 350,000 pages. When the `PERFORM PRINTER MAINTENANCE` message appears on the control panel, you will need to purchase a Printer Maintenance Kit and install the new parts. Then remove the message by turning the service message off in the Configuration Menu. To reset the pages, turn the printer off, hold down the **ITEM** - and the **VALUE** - keys while turning the printer on. Wait for `RESET MAINT/COUNT` to display on the control panel before releasing the keys.



For ordering information, see page [42](#). For more information on installing the Printer Maintenance Kit, see the instructions that come with it.

### ***HP Policy on Non-HP Printer Maintenance Kits***

Hewlett-Packard Company cannot recommend use of non-HP printer maintenance kits, either new or remanufactured. Because they are not HP products, HP cannot influence their design or control their quality.

For more information on the printer maintenance kit, see the instructions that come with it.



## *Managing the Toner Cartridge*



### *HP Policy on Non-HP Toner Cartridges*

Hewlett-Packard Company cannot recommend use of non-HP toner cartridges, either new or remanufactured. Because they are not HP products, HP cannot influence their design or control their quality. Service or repairs required as a result of using a non Hewlett-Packard toner cartridge will NOT be covered under the printer warranty.



To install a new HP toner cartridge and recycle the used cartridge, follow the instructions included in the toner cartridge box and refer to the recycling guide included in the box.



### *Toner Cartridge Storage*

Do not remove the toner cartridge from its package until you are ready to use it.

---

**CAUTION**

To prevent damage to the toner cartridge, do not expose it to light for more than a few minutes. Do not store the toner cartridge at temperatures above 95° F (35° C) or below 32° F (0° C).

---



## Toner Cartridge Life Expectancy

The life of the toner cartridge depends on the amount of toner that print jobs require. When printing text at 5% coverage, an HP toner cartridge lasts an average of 20,000 pages. (A typical business letter is about 5% coverage.) This assumes that print density is set to 3 and EconoMode is off. (These are the default settings.)



## Checking the Toner Level

The user can find out how much toner is left in the printer cartridge by printing a configuration page (see page [314](#)). The Toner Level section on the configuration page provides a graphical representation of how much toner is left in the cartridge.

---

### Note

This value might become inaccurate if a user fails to select YES when the NEW TONER CARTRIDGE=NO message is displayed on the control panel after replacing a low toner cartridge.

---





## Resetting the HP TonerGauge

After a new toner cartridge is installed, the user must reset the HP TonerGauge from the control panel. When the top cover is closed after installing the new toner cartridge, the NEW TONER CARTRIDGE=NO message is displayed on the control panel for approximately 30 seconds. To reset the HP TonerGauge:



### Note

If the NEW TONER CARTRIDGE=NO message is no longer displayed on the control panel, press **MENU** repeatedly until CONFIGURATION MENU appears. When you replace an empty or low toner cartridge, press **ITEM** repeatedly until NEW TONER CARTRIDGE=NO appears.

- 1 Press - **VALUE** + until YES appears.
- 2 Press **SELECT** to save the selection.
- 3 Press **GO** to exit the menu.



## Continue Printing When Toner is Low

When toner is low, the printer's control panel displays the TONER LOW message.

If the TONER LOW message displays, but the printer continues printing, TONER LOW is set to CONTINUE (the default setting).

If the printer stops printing when low toner is detected, TONER LOW is set to STOP. To resume printing, press **Go**.

The printer will continue to display TONER LOW until you replace the toner cartridge.



---

**Note** After you replace an empty or low toner cartridge, refer to [“Resetting the HP TonerGauge”](#) on page [193](#).

---

Select TONER LOW=CONTINUE or TONER LOW=STOP from the Configuration Menu in the control panel (page [445](#)).



## Redistributing the Toner

When toner is low, faded or light areas might appear on a printed page. You might be able to temporarily improve print quality by redistributing the toner. The following procedure might allow you to finish the current print job before replacing the toner cartridge.

- 1 Open the top cover.
- 2 Remove the toner cartridge from the printer.
- 3 Rotate the toner cartridge and gently shake it from side to side to redistribute the toner.

---

### Note

If toner gets on your clothing, wipe it off with a dry cloth and wash clothing in cold water. (Hot water sets toner into fabric.)

---

Continued on next page.

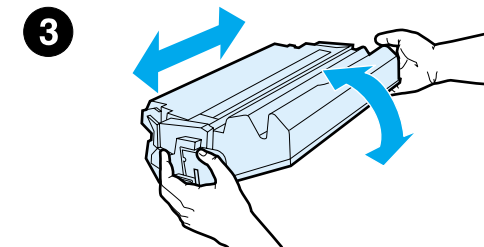
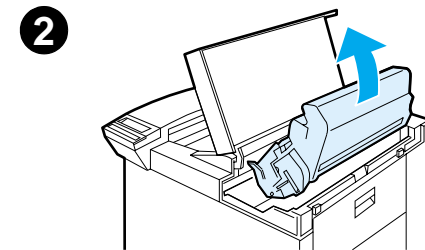
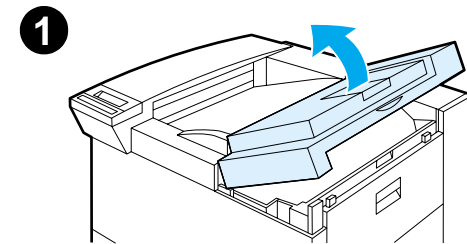

- 4 Reinsert the toner cartridge into the printer and close the top cover.

If the print remains light, install a new toner cartridge. (Follow the instructions provided with the new toner cartridge.)

4

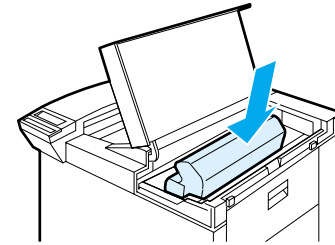

## *Cleaning the Printer*

To maintain print quality, clean the printer thoroughly:

- Every time you change the toner cartridge.
- Whenever print quality problems occur.

Clean the outside of the printer with a lightly water-dampened cloth. Clean the inside with only a dry, lint-free cloth. Observe all warnings and cautions with the cleaning tasks on the following page.



**CAUTION** Avoid touching the fusing area when cleaning the printer. It may be hot.

To avoid permanent damage to the toner cartridge, do not use ammonia-based cleaners on or around your printer.

**Continued on next page.**



- 1 Before you begin these steps, turn the printer off and unplug all cables.
- 2 Open the top cover of the printer and remove the toner cartridge.

**CAUTION**

Do not touch the transfer roller (A). Skin oils on the roller can reduce print quality. If toner gets on your clothes, wipe it off with a dry cloth and wash your clothes in cold water. Hot water sets toner into fabric.

- 3 With a dry lint-free cloth, wipe any residue from the paper path area, the registration roller (B), and the toner cartridge cavity.
- 4 Replace the toner cartridge, close the printer, reconnect all cables, and turn the printer on.

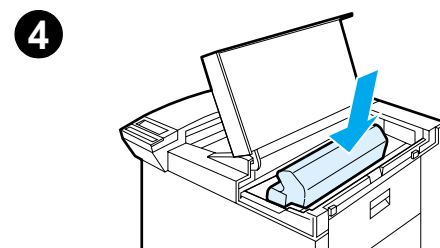
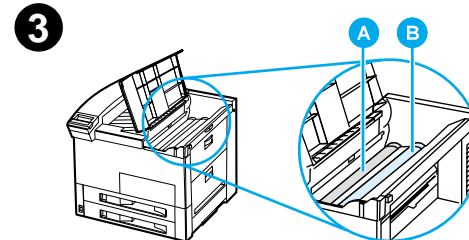
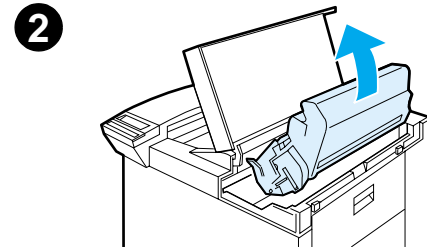
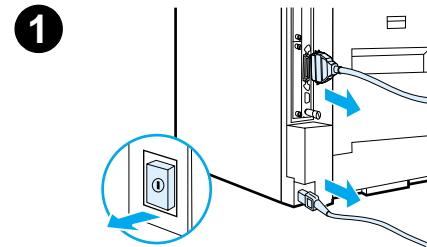

## ***Using the Printer Cleaning Page***

If toner specks appear on the front or back side of your print jobs, follow the procedure below.

From the printer's control panel, do the following:

- 1 Press **MENU** repeatedly until PRINT QUALITY MENU appears.
- 2 Press **ITEM** repeatedly until CREATE CLEANING PAGE appears.
- 3 Press **SELECT** to create the cleaning page.
- 4 Follow the instructions on the cleaning page to complete the cleaning process.



---

**Note** In order for the cleaning page to work properly, print the page on copier grade paper (not bond or rough paper).

---

When toner has been cleaned from inside the printer, shiny black spots will appear on the page's black strip. If white spots appear on the black strip, print another cleaning page.

To ensure good print quality with certain types of paper, use the cleaning page every time the toner cartridge is replaced. If the cleaning page is frequently needed, try a different type of paper.



# 5 Problem Solving



## Overview

This chapter will help you to solve printer problems.

---

**[Clearing Paper Jams](#)**  
(see page [202](#))

Occasionally, paper can jam during printing. This section will help you to locate paper jams, properly clear them from the printer, and solve repeated paper jams.

**[Understanding Printer Messages](#)**  
(see page [226](#))

Many different messages can appear on the printer's control panel display. Some messages tell the printer's current status, such as INITIALIZING. Other messages require an action, such as CLOSE TOP COVER. Many of these messages are self-explanatory. However, some messages indicate a problem with the printer, or require further action or description. This section lists these types of messages and tells what to do if a message persists.





---

**[Correcting Output Quality Problems](#)**  
(see page [254](#))

The printer should produce print jobs of the highest quality. If print jobs do not look sharp and clear, defects such as lines, specks, or smears appear on the page, or paper is wrinkled or curled, use this section to troubleshoot and solve the output quality problem.



**[Printer Problems](#)**  
(see page [264](#))

Before you can fix a printer problem, you must understand where the problem is. Use the tables in this section to determine the printer problem, and then follow the corresponding troubleshooting suggestions.



**[Checking the Printer's Configuration](#)**  
(see page [313](#))

From the printer, you can print information pages that give details about the printer and its configuration.



**[HP Digital Copy Problem Solving](#)**  
(see page [377](#))

This section shows status messages that display on the HP Digital Copy control panel when there is a problem with the HP Digital Copy. See this section if you are having problems with the digital copy and sender functions.

---



## Clearing Paper Jams

If the printer's control panel displays a paper jam message, look for paper in the locations indicated in the [graphic](#) on page [203](#), then see the procedure for clearing the paper jam. You might need to look for paper in other locations than indicated in the paper jam message. If the location of the paper jam is not obvious, look first in the top cover area.

When clearing paper jams, be very careful not to tear the paper. If a small piece of paper is left in the printer, it could cause additional jams. If paper jams are a recurring problem, see page [224](#).



---

**Note** After the jam is cleared, the top cover of the printer must be opened and closed to clear the paper jam message from the control panel.

---

**Continued on next page.**



***Paper jams can occur at the following locations:***

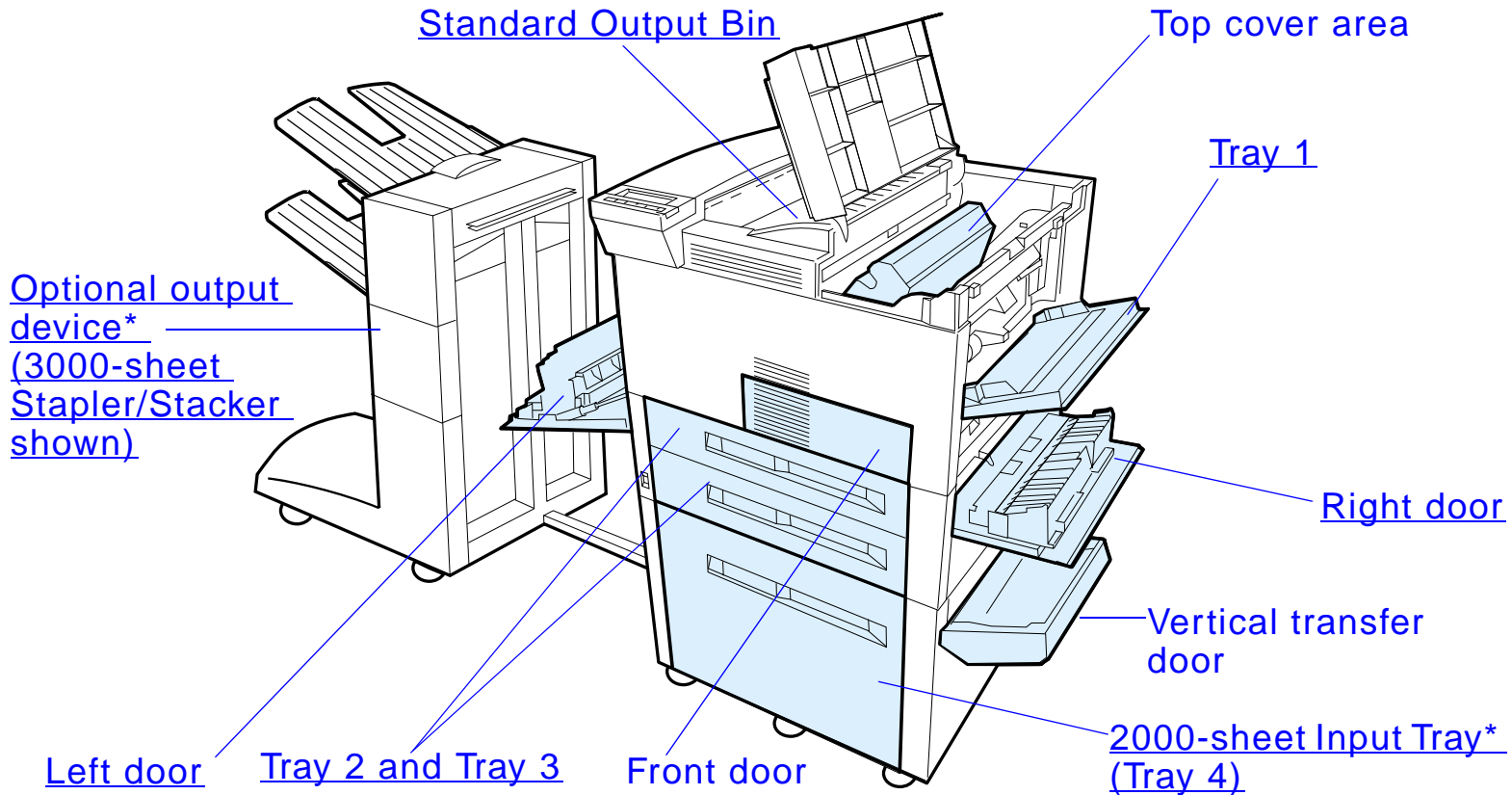

\* Other paper handling accessories may be installed in these positions.

**Note** Loose toner might remain in the printer after a paper jam, but the toner should clear after a few sheets are printed.

***Clearing Paper Jams***



## Clearing Jams from the Input Tray Areas

### Clearing Tray 1

- 1 Open Tray 1 by pulling down.
- 2 Check for paper in the Tray 1 area.
- 3 Remove any paper from this area by pulling it in the direction shown by the arrow in the graphic below. Carefully check to be sure you have removed all pieces of torn paper.
- 4 Open and close the top cover.

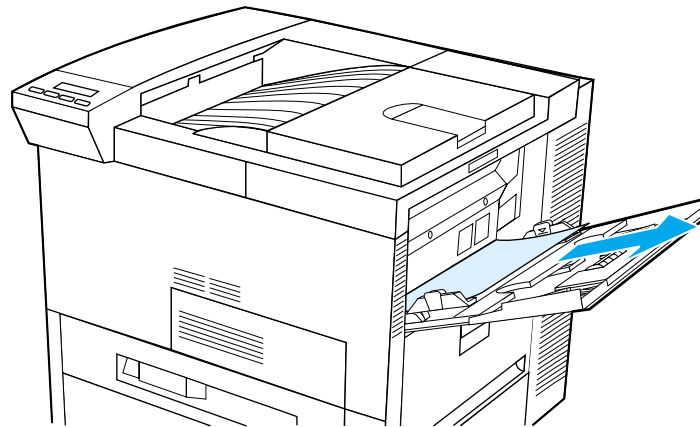

## Clearing the Right Door

- 1 Open the right door located below Tray 1.
- 2 Check for paper in this area.
- 3 Open the jam access cover using the green lever.
- 4 Remove any paper from this area by pulling it out of the printer.
- 5 Be sure to remove all pieces of torn paper.

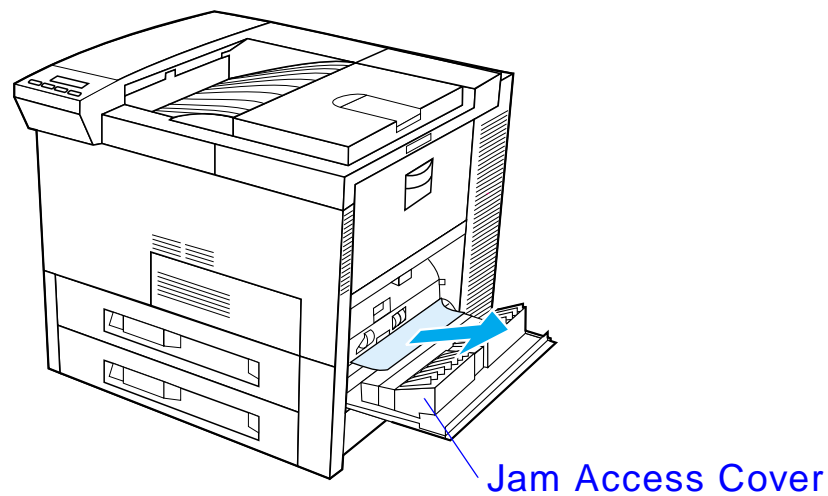

## Clearing Trays 2 and 3

- 1 Open the tray.
- 2 Remove jammed or damaged paper from this area by pulling it out of the printer.
- 3 Be sure to remove all pieces of torn paper.
- 4 Close the tray.
- 5 Open and close the top cover.

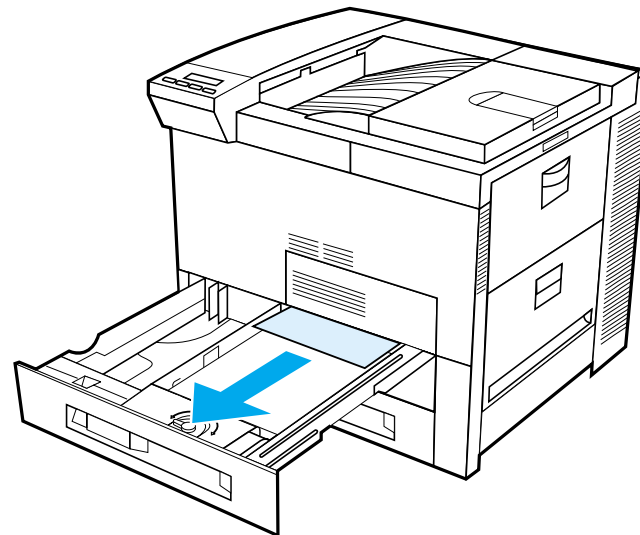

## ***Clearing the Optional 2 x 500-sheet Input Trays (4 and 5)***

- 1 Open the tray.
- 2 Remove damaged or jammed paper from area (A) by pulling it out of the printer.
- 3 Be sure to remove all pieces of torn paper.
- 4 Close the tray.
- 5 Open the vertical transfer door and remove jammed paper (B).
- 6 Close the vertical transfer door.
- 7 Open and close the top cover.

**Continued on next page.**



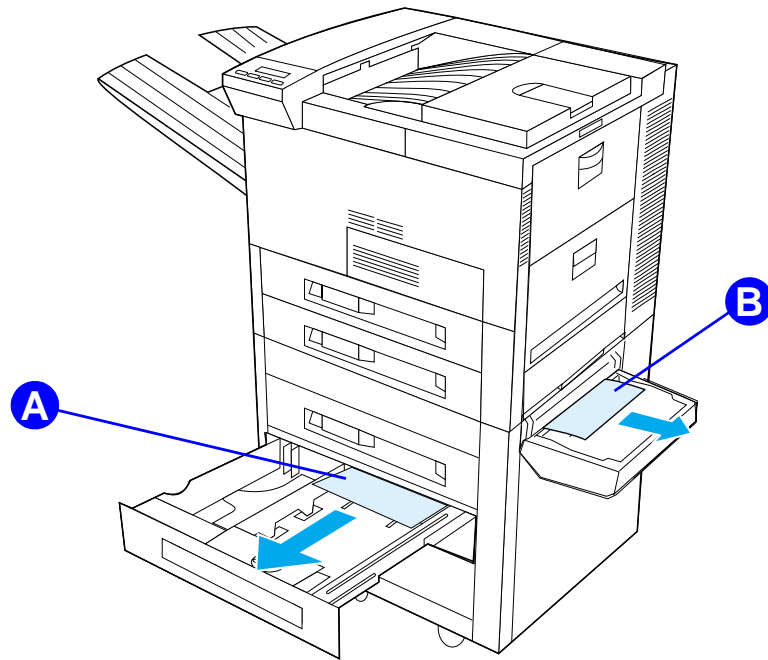

*Clearing Paper Jams*



### ***Clearing the Optional 2000-sheet Input Tray (Tray 4)***

- 1 Open Tray 4.
- 2 Remove damaged or jammed paper from area (A) by pulling it out of the printer.
- 3 Be sure to remove all pieces of torn paper.
- 4 Close the tray.
- 5 Open the vertical transfer door and remove all jammed paper (B).
- 6 Close the vertical transfer door.
- 7 Open and close the top cover.

**Continued on next page.**



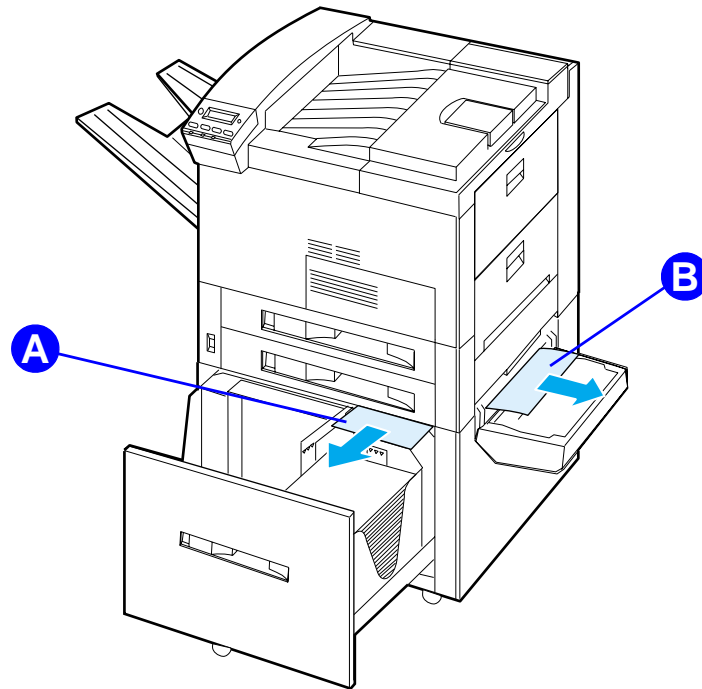

*Clearing Paper Jams*

## ***Clearing the Optional Envelope Feeder***

- 1 Open the top cover.
- 2 Remove toner cartridge (A).
- 3 Remove envelopes in this area by pulling them straight up and out of the envelope feeder (B).
- 4 Be sure to remove any pieces of torn paper. Lift both of the green user tabs and remove any envelopes that may be hidden (C).
- 5 You may need to remove any loaded envelopes and the optional envelope feeder to release envelopes or torn pieces of paper.
- 6 Replace the optional envelope feeder and toner cartridge and close the top cover.

**Continued on next page.**



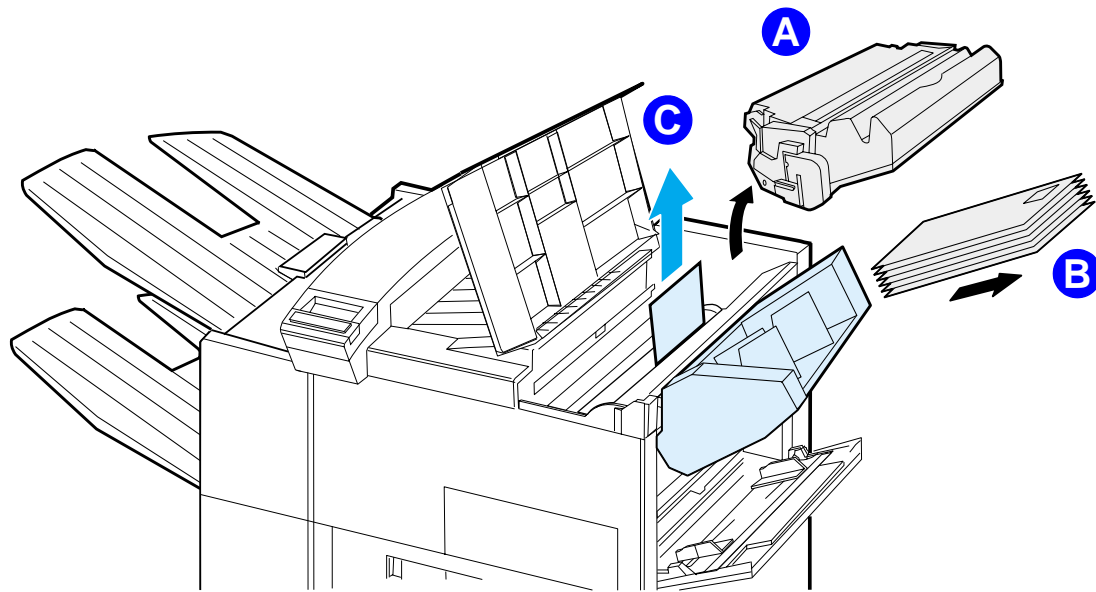

## Clearing Jams from the Optional Duplex Printing Accessory

- 1 Open the front door.
- 2 Check for paper in this area.
- 3 Remove any paper from area (A) by pulling it out of the printer. Be careful not to tear the paper.
- 4 If you cannot remove all the paper through the front door, open the left door and carefully pull out any paper from area (B). (If a mailbox accessory is installed, first push it away from the printer to access the left door.)



**WARNING!** Avoid touching the adjacent fusing area. It may be HOT.

- 5 If a duplexer is installed, turn the printer off and remove the duplexer by pressing the colored tab on the lower right side of the unit and pulling the entire unit out of its slot.
- 6 Remove any paper remaining in the duplexer (C).

**Continued on next page.**



- 7 Reinstall the duplexer by sliding it back into the slot until it clicks into place. Close all open doors. If an optional output device is installed, push it back into place and turn the printer on.

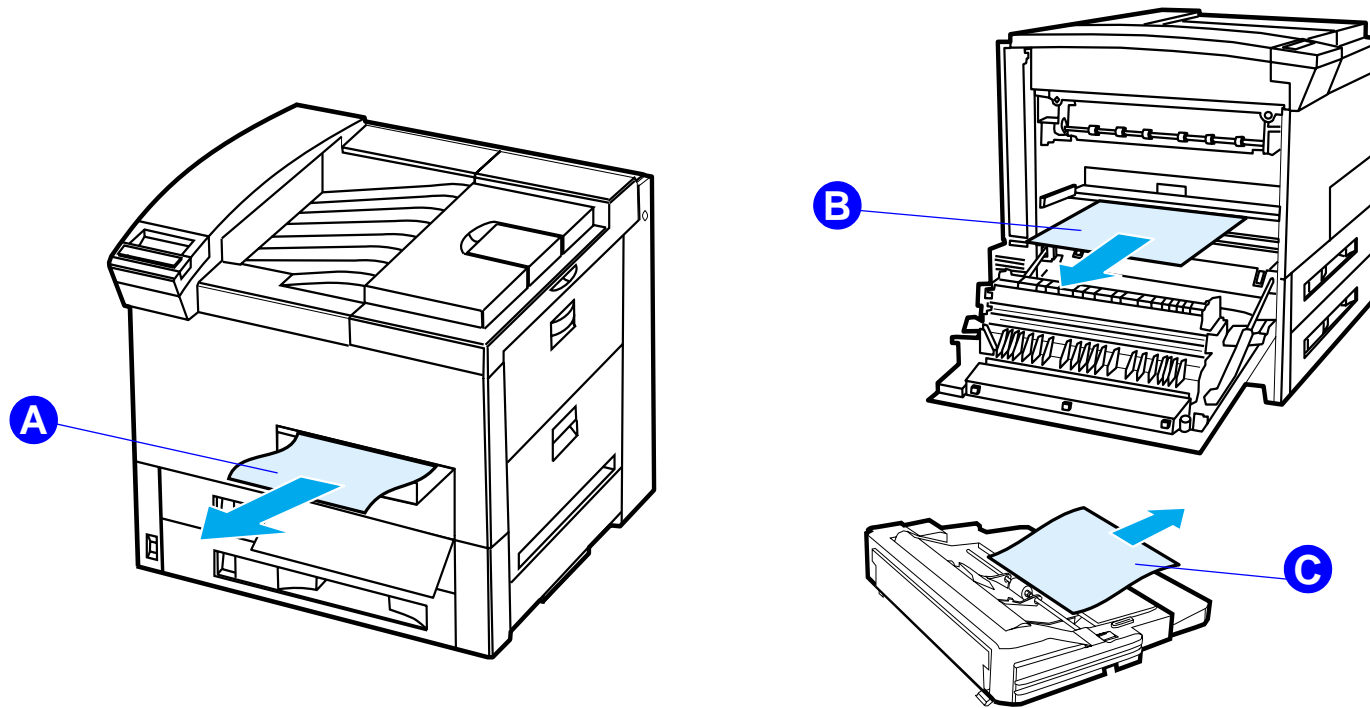

## Clearing Jams from the Top Cover Area

- 1 Open the top cover.
- 2 Remove the toner cartridge (A).
- 3 Lift the green lever and remove any paper that may be hidden.
- 4 Remove any paper in this area by pulling it straight up and out of the printer (B).
- 5 Be sure to remove all pieces of torn paper.
- 6 Replace the toner cartridge and close the top cover.

**Continued on next page.**



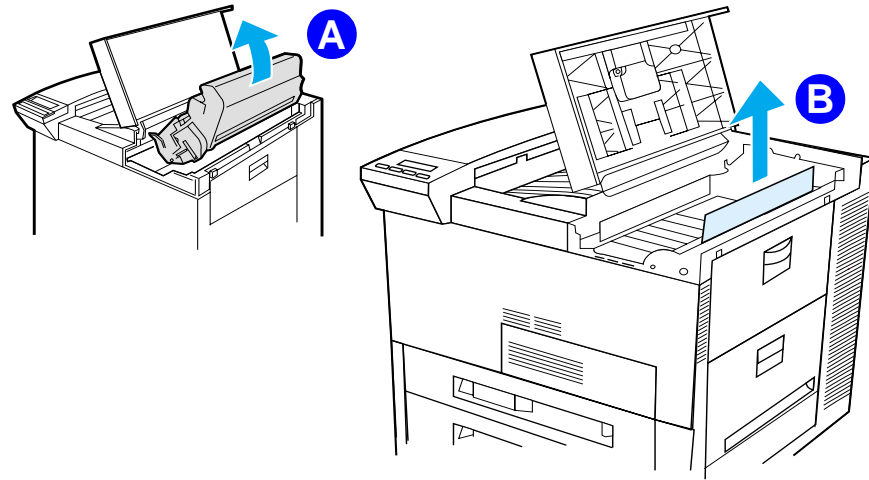



## Clearing Jams from the Output Areas

### Clearing the Standard Output Bin

If the paper jam extends into the output area, as shown in the graphic below, slowly and carefully pull the paper straight out of the printer so that it does not tear.

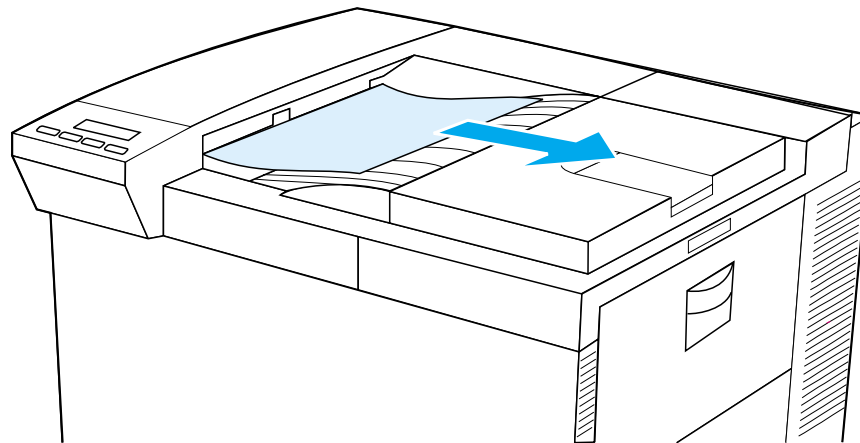

## Clearing the Left Door (Fuser Area)

- 1 Open the left door. (If an optional output device is installed, first push it away from the printer to access the left door.)



**WARNING!** Avoid touching the adjacent fusing area. It may be HOT.



- 2 Remove any jammed or damaged paper from this area by pulling it out of the printer (A).
- 3 Press down on the green tabs (B) and carefully check for paper. Be sure to remove all pieces of torn paper.
- 4 Close the left door. If an optional output device is installed, push it back into place.

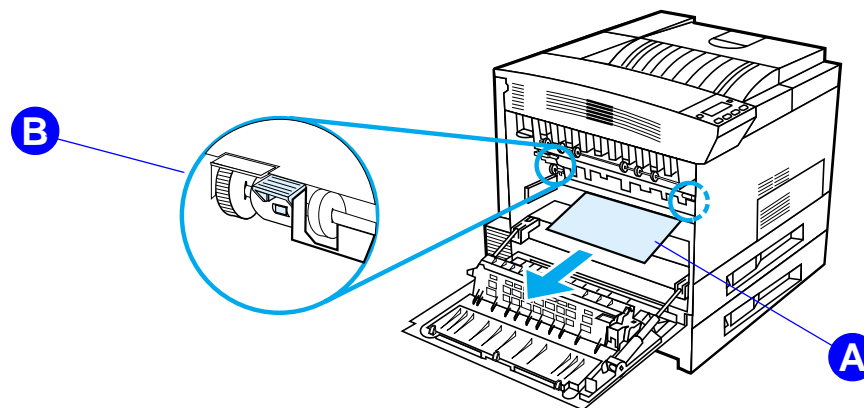

## Clearing the Optional Multibin Mailboxes

- 1 Remove the Face-up Bin.
- 2 Remove paper from area (A) by carefully pulling it out, away from the printer.
- 3 Pull the mailbox away from the printer and remove any paper in area (B). Be sure to remove any torn pieces of paper.



**WARNING!** Avoid touching the adjacent fusing area or area (C). It may be HOT.

- 4 Remove any paper in area (C) by carefully pulling it out of the printer.

**Note** When clearing paper jams, be very careful not to tear the paper. If a small piece of paper is left in the printer, it could cause additional jams. If paper jams are a recurring problem, see page [224](#).

**Continued on next page.**



- 5 Remove any paper that is only partially in the output bins.
- 6 Remove any paper from the vertical transportation path (D) on the back of the mailbox. You may need to open a door.
- 7 Push the mailbox into place.

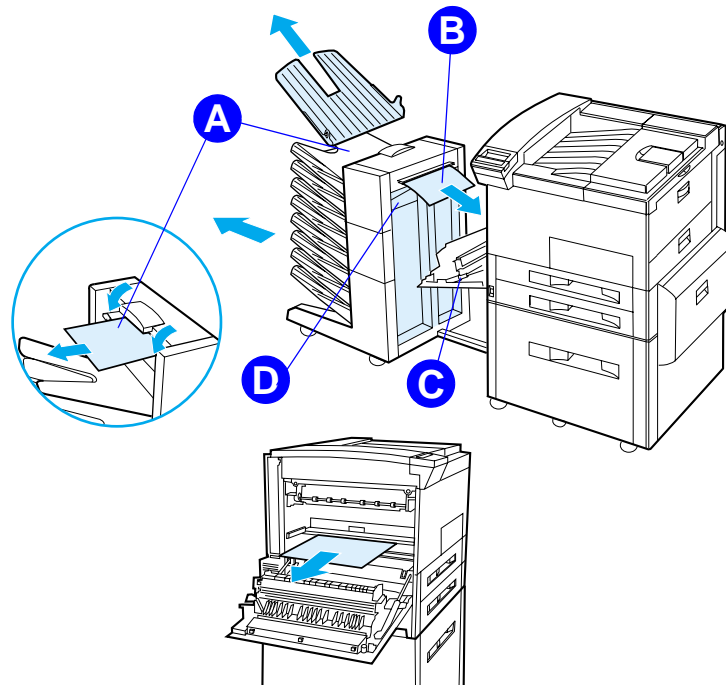

## Clearing Jams from an Optional HP Output Device

For more information on an optional HP output device, see the user guide that came with the device.



## Clearing Jams from the Stapler (5-bin Mailbox with Stapler)



---

### Note

For more information on an optional HP output device, see the user guide that came with the device.

---

- 1 Remove the Face-up Bin.
- 2 Open the stapler unit cover.
- 3 Press the colored tab with your forefinger and pull the colored circular tab with your other forefinger to open the stapler.

Continued on next page.

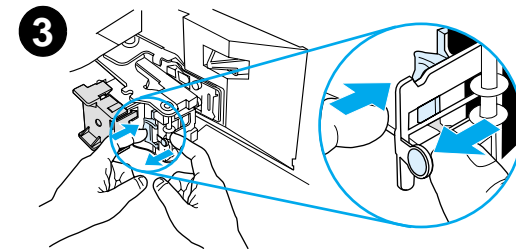
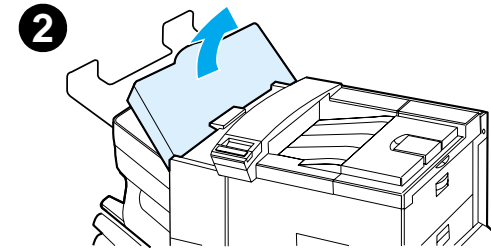
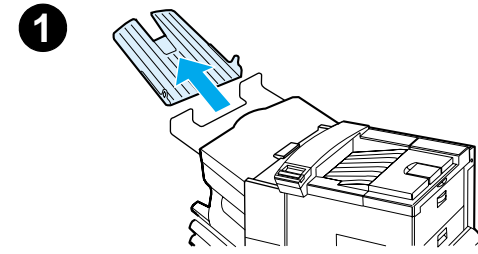

- 4 Remove loose or damaged staples from the stapler head. Push the circular tab to snap it back into place.
- 5 Close the stapler unit cover and replace the Face-up Bin. Clear all paper paths that may have jammed as a result of the jammed staples.

---

**Note**

After clearing a stapler jam, up to two documents may not be stapled when printing resumes because the stapler must reload. Once the unit begins stapling again, either manually staple the unstapled documents or resend the job.

If a print job is sent and the stapler is jammed or out of staples, the job will still print.

---

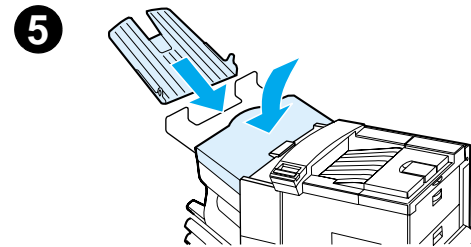
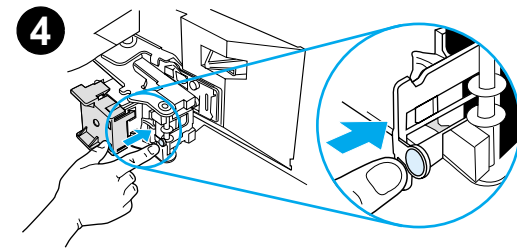

## Solving Repeated Paper Jams



---

**Situation****Solution**

---

General repeated paper jam problems

1. Check to see that paper is correctly loaded in the trays and that all width guides are correctly set (not skewed). See Chapter 2, "[Printing Tasks](#)."
2. Make sure that the paper tray is set for the size of paper installed and that the tray is not overloaded with paper.
3. Try turning over the stack of paper in the tray. If you are using prepunched or letterhead paper, try printing from Tray 1.
4. Do not use previously printed paper or torn, worn, or irregular paper. For recommended paper and other paper for your printer, see page [390](#).
5. Check the paper specifications (page [390](#)). (If paper is outside of the recommended specifications, problems may occur.)



**Continued on next page.**



***Clearing Paper Jams***



---

**Situation****Solution**

---

6. When duplexing, the printer rolls paper under Tray 3 and may cause a jam. Pull Tray 3 out of the printer completely and remove any paper from under the tray. Insert Tray 3 back into the printer.
  7. Printer may be dirty. Clean the printer as described on page [197](#).
  8. Check that the correct paper size is installed (page [390](#)).
  9. Check that all damaged or jammed paper is removed by pulling it out of the printer.
- 



---

**Note**

If jams continue, contact your authorized HP service provider.



## Understanding Printer Messages

The table on page [227](#) explains messages that might display on the printer's control panel. Printer messages and their meanings are listed in alphabetical order, with numbered messages following.

### If a message persists:

- If a message persists requesting that you load a tray or if a message indicates that a previous print job is still in the printer's memory, press **Go** to print or press **CANCEL JOB** to clear the job from the printer's memory.
- If a message persists after performing all of the recommended actions, contact an HP-authorized service or support provider. (See the [HP Customer Care](#) pages at the front of this user guide.)



---

### Note

Not all messages are described in this user guide (many are self-explanatory).

Some printer messages are affected by the `AUTO CONTINUE` and `CLEARABLE WARNING` settings from the Configuration Menu in the printer's control panel (page [445](#)).

---



## Using the Printer Online Help System

**Note** For more information on an optional HP output device, see the user guide that came with the device.

This printer features an online Help system that provides instructions for resolving most printer errors. Certain control panel error messages alternate with instructions on accessing the online help system.

Whenever a ? appears in a error message or a message alternates with FOR HELP PRESS THE ? KEY, press the **ITEM** key to navigate through a sequence of instructions.

To exit the online Help system, press **Go**.



### Printer Messages

Message	Explanation or Recommended Action
ACCESS DENIED MENUS LOCKED	The printer control panel function you are trying to access has been locked to prevent unauthorized access.  See your network administrator.



### Understanding Printer Messages

**Printer Messages (continued)**

Message	Explanation or Recommended Action
BAD DUPLEXER CONNECTION	The duplexer is not connected properly. Turn the printer off. Re-install the duplexer. Turn the printer back on.
CHECK FINISHER DEVICE alternates with CLEAR JAM	The finishing device, such as a stapler, has a jam. Remove jammed paper from the specified location. Open and close the top cover to clear the message. Make sure that the finishing device is properly connected. If the message persists, see the user guide that came with the device.
CHECK FINISHER DEVICE alternates with FINISHER ALIGN ERROR	The finisher cannot bind the paper correctly. The paper feeding into the device is mis-aligned. Remove any jammed paper. Align the paper properly and reprint the job if necessary. If the message persists, see the user guide that came with the device.



**Printer Messages (continued)**

<b>Message</b>	<b>Explanation or Recommended Action</b>
CHECK INPUT DEVICE  alternates with  PAPER PATH OPEN PLEASE CLOSE IT	The optional input tray cannot feed paper to the printer because a door or paper guide is open.  Check the doors and paper guides.
CHECK OUTPUT DEVICE  alternates with  CLOSE OUTPUT DELIVERY PATH	The optional output device is not properly connected to the printer. A proper connection must be made for printing to continue.
CHECKING PAPER PATH	The engine is rolling its rollers to check for possible paper jams.
CHOSEN LANGUAGE NOT AVAILABLE	A print job requested a printer language that does not exist in the printer. The job will not print and will be cleared from memory.  Print the job using a driver for a different printer language, or add the requested language to the printer (if available).  Press <b>Go</b> to continue.

**Understanding Printer Messages**

**Printer Messages (continued)**

<b>Message</b>	<b>Explanation or Recommended Action</b>
CLOSE RIGHT DOOR	The right access door is open and must be closed for printing to continue.
CLOSE TOP OR LEFT DOOR	Either the top cover or the left door is open and must be closed for printing to continue.
DISK DEVICE FAILURE	The EIO disk had a critical failure and can no longer be used. Reseat the EIO disk. If the message continues, replace it with a new EIO disk.
DISK FILE OPERATION FAILED	The requested operation could not be performed. You might have attempted an illegal operation, such as trying to download a file to a non-existent directory.
DISK FILE SYSTEM IS FULL	Delete files from the EIO disk and then try again. Use HP LaserJet Resource Manager to download or delete files and fonts. (See the software help for more information.)
DISK IS WRITE PROTECTED	The EIO disk is protected, and no new files can be written to it. Disable the write protection through HP LaserJet Resource Manager.

**Understanding Printer Messages**

**Printer Messages (continued)**

Message	Explanation or Recommended Action
EIO n NOT FUNCTIONAL	The EIO network card is not working correctly. Reseat the EIO accessory. If the message continues, replace it with a new EIO accessory.
EIO n DISK INITIALIZING	The disk accessory card takes a long time to initialize. The first parameter is the accessory slot number for this disk accessory card.
EIO n DISK NOT FUNCTIONAL	The EIO disk is not working correctly. Remove the EIO disk from the slot indicated. Reseat the EIO disk. If the message continues, replace it with a new EIO disk.



*Printer Messages (continued)*

Message	Explanation or Recommended Action
EIO n INITIALIZING  alternates with  DO NOT POWER OFF	<p>Wait for the message to disappear (approximately 5 minutes). If the printer EIO card is operating correctly and communicating with the network, this message disappears after approximately one minute and no action is required.</p> <p>If the EIO card is unable to communicate with the network, this message remains for five minutes and then disappears. In this case the printer is not communicating with the network (even though the message is no longer present). The problem may be a bad EIO card, a bad cable or connection on the network, or a network problem. Contact your network administrator.</p>
EIO n DISK SPINNING UP	The disk accessory card takes a long time to initialize. The first parameter is the accessory slot number for this accessory card.
ENV FEEDER LOAD [TYPE] [SIZE]	<p>Load the requested envelope type and size into the envelope feeder.</p> <p>Make sure the envelope size and type are set correctly from the Paper Handling Menu in the printer's control panel (page <a href="#">427</a>).</p> <p>Press <b>Go</b> if the desired envelope is already loaded in the feeder.</p> <p>Press <b>- VALUE +</b> to scroll through the available types and sizes.</p> <p>Press <b>SELECT</b> to accept the alternate type or size.</p>

*Understanding Printer Messages*



**Printer Messages (continued)**

<b>Message</b>	<b>Explanation or Recommended Action</b>
EXTERNAL DEVICE INITIALIZING	When an external paper handling device is connected to the printer, it must have 10 seconds to initialize after power on or after coming out of PowerSave mode.
FINISHER LOW ON FINISHING AGENT	The finishing device is running out of its finishing material and needs to be refilled.
FLASH n INITIALIZING alternates with DO NOT POWER OFF	The flash DIMM can take a long time to initialize the first time that it is used.
FLASH DEVICE FAILURE	The flash DIMM had a critical failure and no longer can be used. Remove the flash DIMM and replace it with a new one.
FLASH FILE OPERATION FAILED	The requested operation could not be performed. You might have attempted an illegal operation, such as trying to download a file to a non-existent directory.
FLASH FILE SYSTEM IS FULL	Delete files from the flash DIMM. Use HP LaserJet Resource Manager to download or delete files and fonts. (See the software help for more information.)

**Understanding Printer Messages**

*Printer Messages (continued)*

Message	Explanation or Recommended Action
FLASH IS WRITE PROTECTED	The flash DIMM is protected and no new files can be written to it. Disable the write protection through HP LaserJet Resource Manager.
INPUT DEVICE CONDITION xx.yy	An input paper handling device has a condition that needs attention before printing can resume.  See the documentation that came with the paper handling device for assistance.
INSTALL TONER CARTRIDGE	The toner cartridge has been removed and must be replaced for printing to continue.
INSTALL TRAY X	The specified tray is not installed and must be inserted and closed for printing to continue.
LOADING PROGRAM <number>  alternates with  DO NOT POWER OFF	Programs and fonts can be stored on the printer's file system. At bootup time these entities are loaded into RAM. (These entities can take a long time to load into RAM depending on the size and number of entities being loaded.) The <number> specifies a sequence number indicating the current program being loaded.

*Understanding Printer Messages*

**Printer Messages (continued)**

Message	Explanation or Recommended Action
MANUALLY FEED [TYPE] [SIZE]	Load the requested paper into Tray 1. Press <b>Go</b> if the desired paper is already loaded in Tray 1.
MEMORY FULL STORED DATA LOST	There is no available memory in the printer. The current job might not print correctly and some resources (such as downloaded fonts or macros) might have been deleted. You might want to add more memory to the printer (page <a href="#">467</a> ).
MEMORY SETTINGS CHANGED	The printer changed its memory settings because it did not have enough memory to use the previous settings for I/O Buffering and Resource Saving. This usually occurs after removing memory from the printer, adding a duplexer, or adding a printer language. You might want to change memory settings for I/O Buffering and Resource Saving (although default settings are usually best) or add more memory to the printer (page <a href="#">467</a> ).



**Printer Messages (continued)**

Message	Explanation or Recommended Action
MEMORY SHORTAGE JOB CLEARED	<p>The printer did not have enough free memory to print the entire job. The remainder of the job will not print and will be cleared from memory.</p> <p>Press <b>Go</b> to continue.</p> <p>Change the Resource Saving setting from the printer's control panel (page <a href="#">420</a>) or add more memory to the printer (page <a href="#">467</a>).</p>
MEMORY SHORTAGE PAGE SIMPLIFIED	<p>The printer had to compress the job in order to fit it in available memory. Some data loss might have occurred.</p> <p>Press <b>Go</b> to continue.</p> <p>The print quality of these pages may not be acceptable. Reduce the complexity of these pages and reprint them.</p> <p>You might want to add more memory to the printer (page <a href="#">467</a>).</p>
MOPY PAGE TOO COMPLEX alternates with PRESS GO TO CONTINUE	<p>The data (dense text, rules, raster or vector graphics) sent to the printer was too complex.</p> <p>Press <b>Go</b> to print the transferred data. (Some data might be lost.)</p> <p>If this message appears often, simplify the print job.</p>

**Understanding Printer Messages**

**Printer Messages (continued)**

<b>Message</b>	<b>Explanation or Recommended Action</b>
OFFLINE	Press <a href="#">Go</a> to place the printer online.
OUTPUT BIN FULL CLEAR (BIN nnn) n (bin name)	The output bin is full and needs to be emptied.
OUTPUT DEVICE CONDITION xx.yy	A recoverable error occurred in an external paper handling device. Push the mailbox away from the printer, and then re-attach it.  If this message persists, contact an HP-authorized service or support provider. (See the <a href="#">HP Customer Care</a> pages at the front of this user's guide.)
PERFORM PRINTER MAINTENANCE	To ensure optimum print quality, the printer prompts you to perform routine maintenance every 350,000 pages. To order a Printer Maintenance Kit, see page <a href="#">42</a> .
RAM DISK DEVICE FAILURE	The RAM disk had a critical failure and can no longer be used.  Turn the printer off, and then turn the printer on to clear the message.

**Understanding Printer Messages**

*Printer Messages (continued)*

Message	Explanation or Recommended Action
RAM DISK FILE OPERATION FAILED	The requested operation could not be performed. You might have attempted an illegal operation, such as trying to download a file to a non-existent directory.
RAM DISK FILE SYSTEM IS FULL	Delete files and then try again, or turn the printer off, and then turn the printer on to delete all files on the device. (Delete files using HP LaserJet Resource Manager or another software utility. See the software help for more information.)  If the message persists, increase the size of the RAM disk. Change the RAM disk size from the Configuration Menu in the printer's control panel (page <a href="#">445</a> ).
RESEND UPGRADE	There is an error in the printer's firmware flash. Resend a valid firmware image.
STAPLER LOW ON STAPLES	The stapler device is running out of staples and needs to be refilled.
STAPLER OUT OF STAPLES	The stapler device is out of staples and needs to be reloaded.
TONER LOW	See page <a href="#">194</a> .

*Understanding Printer Messages*

*Printer Messages (continued)*

Message	Explanation or Recommended Action
TRAY x EMPTY	<p>Load the empty tray (x) to clear the message.</p> <p>If you do not load the specified tray, the printer will continue printing from the next available tray, and the message will continue to display.</p>
TRAY x LOAD [TYPE] [SIZE]	<p>Load the requested paper into the specified tray (x). (See the sections on loading paper, starting on page <a href="#">89</a>.)</p> <p>Make sure that the trays are correctly adjusted for size. The tray type settings (and size for Tray 1) must be set from the printer's control panel (page <a href="#">157</a>).</p> <p>If you are trying to print A4 or letter size paper and this message appears, make sure the default paper size is set correctly from the Printing Menu in the printer's control panel.</p> <p>Press <b>Go</b> to print from the next available tray.</p> <p>Press <b>- VALUE +</b> to scroll through the available types and sizes.</p> <p>Press <b>SELECT</b> to accept the alternate type or size.</p>

**Printer Messages (continued)**

Message	Explanation or Recommended Action
TRAY 2 LOAD LEGAL (or similar messages requesting that you load paper)	Load the requested paper into the indicated tray, or press <b>SELECT</b> to override the message and to print on a loaded paper size.  If printing does not continue, press <b>Go</b> .
UNABLE TO MOPY JOB	Memory or file system configuration would not allow a mopy job to occur. Only one copy will be produced.
UNABLE TO STORE JOB	A job cannot be stored on the printer because of memory or file system configuration.
UNSUPPORTED SIZE IN TRAY [YY]	An external paper handling device detected an unsupported paper size. The printer will go offline until the condition is corrected.
USE [TYPE] [SIZE] INSTEAD?	If the requested paper size or type is not available, the printer asks if it should use another paper size or type instead.  Press - <b>VALUE</b> + to scroll through the available types and sizes. Press <b>SELECT</b> to accept the alternate type or size.

**Understanding Printer Messages**



**Printer Messages (continued)**

Message	Explanation or Recommended Action
WAIT FOR PRINTER TO REINITIALIZE	<p>The RAM disk setting has been changed from the printer's control panel. This change will not take effect until the printer reinitializes.</p> <p>If you change the mode of the external device, turn the printer off, turn the printer on and wait for the printer to reinitialize.</p>
WRONG ENVELOPE FEEDER INSTALLED	<p>The envelope feeder you are trying to install will not work for this printer.</p> <p>To order an envelope feeder for the printer, see page <a href="#">42</a>.</p> <p>Make sure the envelope feeder is installed correctly (page <a href="#">125</a>).</p>
XX.YY PRINTER ERROR PRESS GO TO CONTINUE	<p>A printer error has occurred that can be cleared by pressing <b>Go</b> in the printer's control panel.</p>



**Printer Messages (continued)**

Message	Explanation or Recommended Action
13.x PAPER JAM [LOCATION]	<p>Remove jammed paper from the specified location (page <a href="#">202</a>).</p> <p>Open and close the top cover to clear the message.</p> <p>If the message persists after all jams have been cleared, a sensor might be stuck or broken. Contact an HP-authorized service or support provider. (See the <a href="#">HP Customer Care</a> pages at the front of this user guide.)</p>
20 INSUFFICIENT MEMORY  alternates with  PRESS GO TO CONTINUE	<p>The printer received more data than can fit in its available memory. You might have tried to transfer too many macros, soft fonts, or complex graphics.</p> <p>Press <a href="#">Go</a> to print the transferred data (some data might be lost), then simplify the print job or install additional memory (page <a href="#">467</a>).</p>



*Printer Messages (continued)*

Message	Explanation or Recommended Action
<p>21 PAGE TOO COMPLEX</p> <p>alternates with</p> <p>PRESS GO TO CONTINUE</p>	<p>The data (dense text, rules, raster or vector graphics) sent to the printer was too complex.</p> <p>Press <a href="#">Go</a> to print the transferred data. (Some data might be lost.)</p> <p>To print the job without losing data, from the Configuration Menu in the printer control panel, set PAGE PROTECT=ON, print the job, and then return PAGE PROTECT=AUTO. (See page <a href="#">445</a>.) Do not leave PAGE PROTECT=ON; it might degrade performance.</p> <p>If this message appears often, simplify the print job.</p>
<p>22 EIO × BUFFER OVERFLOW</p> <p>alternates with</p> <p>PRESS GO TO CONTINUE</p>	<p>Too much data was sent to the EIO card in the specified slot (×). An improper communications protocol may be in use.</p> <p>Press <a href="#">Go</a> to clear the message. (Data will be lost.)</p> <p>Check the host configuration. If this message persists, contact an HP-authorized service or support provider. (See the <a href="#">HP Customer Care</a> pages at the front of this user's guide.)</p>



**Printer Messages (continued)**

Message	Explanation or Recommended Action
<p>22 PARALLEL I/O BUFFER OVERFLOW</p> <p>alternates with</p> <p>PRESS GO TO CONTINUE</p>	<p>Too much data was sent to the parallel port.</p> <p>Check for a loose cable connection and be sure to use a high-quality cable (page <a href="#">48</a>). (Some non-HP parallel cables might be missing pin connections or might otherwise not conform to the IEEE-1284 specification.)</p> <p>This error can occur if the driver you are using is not IEEE-1284 compliant. For best results, use an HP driver that came with the printer (page <a href="#">66</a>).</p> <p>Press <b>Go</b> to clear the error message. (Data will be lost.)</p> <p>If this message persists, contact an HP-authorized service or support provider. (See the <a href="#">HP Customer Care</a> pages at the front of this user guide.)</p>
<p>40 EIO x BAD TRANSMISSION</p> <p>alternates with</p> <p>PRESS GO TO CONTINUE</p>	<p>The connection has been broken between the printer and the EIO card in the specified slot.</p> <p>Press <b>Go</b> to clear the error message and continue printing.</p>



**Printer Messages (continued)**

Message	Explanation or Recommended Action
41.3 UNEXPECTED PAPER SIZE	<p>The paper size you are trying to print is not the same as the control panel setting for Tray 1.</p> <p>Reload the tray with the correct paper size.</p> <p>Make sure that the control panel setting for Tray 1 or the Envelope Feeder is correctly adjusted for size. (The printer will continue trying to print the job until size settings are correct.)</p> <p>After performing the actions above, press <b>Go</b> twice. The page containing the error will automatically be reprinted if jam recovery is enabled. (Or, you might want to press <b>CANCEL JOB</b> to clear the job from the printer's memory.)</p>
41.x PRINTER ERROR  alternates with  PRESS GO TO CONTINUE	<p>A temporary printing error occurred.</p> <p>Press <b>Go</b>. The page containing the error will automatically be reprinted if jam recovery is enabled.</p> <p>If the error does not clear, turn the printer off, then turn the printer on.</p> <p>If this message persists, contact an HP-authorized service or support provider. (See the <a href="#">HP Customer Care</a> pages at the front of this user guide.)</p>

**Understanding Printer Messages**

**Printer Messages (continued)**

Message	Explanation or Recommended Action
50.x FUSER ERROR	<p>An internal error has occurred. Turn the printer off for at least 5 minutes, and then turn the printer on.</p> <p>The message might clear and then reappear when the next print job is sent. If this message persists, contact an HP-authorized service or support provider. (See the <a href="#">HP Customer Care</a> pages at the front of this user guide.)</p>
51.x or 52.x PRINTER ERROR  alternates with  CYCLE POWER TO CONTINUE	<p>A temporary printing error occurred.</p> <p>Turn the printer off, then turn the printer on.</p> <p>If this message persists, contact an HP-authorized service or support provider. (See the <a href="#">HP Customer Care</a> pages at the front of this user guide.)</p>



**Printer Messages (continued)****Message****Explanation or Recommended Action**53.x<sub>y</sub>.zz

PRINTER ERROR

There is a problem with the printer's memory. The DIMM that caused the error will not be used. Values of x, y, and zz are as follows:

x = DIMM type

0 = ROM

1 = RAM

y = Device location

0 = Internal memory (ROM or RAM)

1 to 3 = DIMM slots 1, 2, or 3

zz = Error number

You might need to reseal or replace the specified DIMM.

Turn the printer off, and then replace the DIMM that caused the error.

If this message persists, contact an HP-authorized service or support provider. (See the [HP Customer Care](#) pages at the front of this user guide.)



**Printer Messages (continued)**

Message	Explanation or Recommended Action
<p>55.xx PRINTER ERROR</p> <p>alternates with</p> <p>PRESS GO TO CONTINUE</p>	<p>A temporary printing error occurred.</p> <p>Press <b>Go</b>. The page containing the error will automatically be reprinted if jam recovery is enabled.</p> <p>If the error does not clear, turn the printer off, then turn the printer on.</p> <p>If this message persists, contact an HP-authorized service or support provider. (See the <a href="#">HP Customer Care</a> pages at the front of this user guide.)</p>
<p>56.x</p> <p>PRINTER ERROR</p> <p>alternates with</p> <p>CYCLE POWER TO CONTINUE</p>	<p>A temporary printing error occurred.</p> <p>Turn the printer off, then turn the printer on.</p> <p>If this message persists, contact an HP-authorized service or support provider. (See the <a href="#">HP Customer Care</a> pages at the front of this user guide.)</p>





**Printer Messages (continued)**

Message	Explanation or Recommended Action
<p>57.x PRINTER ERROR</p> <p>alternates with</p> <p>CYCLE POWER TO CONTINUE</p>	<p>A temporary printing error occurred.</p> <p>Turn the printer off, then turn the printer on.</p> <p>If this message persists, contact an HP-authorized service or support provider. (See the <a href="#">HP Customer Care</a> pages at the front of this user guide.)</p>
<p>58.x PRINTER ERROR</p> <p>alternates with</p> <p>CYCLE POWER TO CONTINUE</p>	<p>A temporary printing error occurred.</p> <p>Turn the printer off, then turn the printer on.</p> <p>If this message persists, contact an HP-authorized service or support provider. (See the <a href="#">HP Customer Care</a> pages at the front of this user guide.)</p>
<p>59.x PRINTER ERROR</p> <p>alternates with</p> <p>CYCLE POWER TO CONTINUE</p>	<p>A temporary printing error occurred.</p> <p>Turn the printer off, then turn the printer on.</p> <p>If this message persists, contact an HP-authorized service or support provider. (See the <a href="#">HP Customer Care</a> pages at the front of this user guide.)</p>



**Printer Messages (continued)**

Message	Explanation or Recommended Action
62.x PRINTER ERROR	<p>There is a problem with the printer's memory. The x value refers to the location of the problem:</p> <p>0 = Internal memory 1 to 3 = DIMM slots 1, 2, or 3</p> <p>You might need to replace the specified DIMM.</p> <p>If this message persists, contact an HP-authorized service or support provider. (See the <a href="#">HP Customer Care</a> pages at the front of this user guide.)</p>
64 PRINTER ERROR	<p>A temporary printing error occurred.</p> <p>Turn the printer off, and then turn the printer on.</p> <p>If this message persists, contact an HP-authorized service or support provider. (See the <a href="#">HP Customer Care</a> pages at the front of this user guide.)</p>



**Printer Messages (continued)**

Message	Explanation or Recommended Action
<p>66.xy.zz INPUT DEVICE FAILURE</p> <p>alternates with</p> <p>CHECK CABLES AND CYCLE POWER</p>	<p>An error occurred in an external paper handling device.</p> <p>Turn the printer off, and then turn the printer on.</p> <p>If this message persists, contact an HP-authorized service or support provider. (See the <a href="#">HP Customer Care</a> pages at the front of this user guide.)</p>
<p>66.00.xx Service ERROR</p> <p>alternates with</p> <p>CHECK CABLES AND CYCLE POWER</p>	<p>An error occurred in an external paper handling device.</p> <p>Turn the printer off.</p> <p>Disconnect the cables to all external paper handling devices, and then reconnect them.</p> <p>Turn the printer on.</p> <p>If this message persists, contact an HP-authorized service or support provider. (See the <a href="#">HP Customer Care</a> pages at the front of this user guide.)</p>



**Printer Messages (continued)**

Message	Explanation or Recommended Action
68 NVRAM ERROR CHECK SETTINGS	<p>An error occurred in the printer's nonvolatile memory (NVRAM) and one or more printer settings has been reset to its factory default.</p> <p>Print a configuration page and check the printer settings to determine which values have changed (page <a href="#">314</a>).</p> <p>If this message persists, contact an HP-authorized service or support provider. (See the <a href="#">HP Customer Care</a> pages at the front of this user guide.)</p>
68 NVRAM FULL CHECK SETTINGS	<p>The printer's nonvolatile memory (NVRAM) is full. Some settings might have been reset to the factory defaults.</p> <p>Print a configuration page and check the printer settings to determine which values have changed (page <a href="#">314</a>).</p> <p>Hold down <b>CANCEL JOB</b> while turning the printer on. This will clean up the NVRAM by removing old areas that are not being used.</p> <p>If this message persists, contact an HP-authorized service or support provider. (See the <a href="#">HP Customer Care</a> pages at the front of this user guide.)</p>



**Printer Messages (continued)**

Message	Explanation or Recommended Action
<p>69.x PRINTER ERROR alternates with CYCLE POWER TO CONTINUE</p>	<p>A temporary printing error occurred. Turn the printer off, reseal the duplexer and then turn the printer on. If this message persists, contact an HP-authorized service or support provider. (See the <a href="#">HP Customer Care</a> pages at the front of this user guide.)</p>
<p>79.xxxx PRINTER ERROR</p>	<p>The printer detected an error. The numbers (xxxx) indicate the specific type of error. Turn the printer off, and then turn the printer on. If the message appears only with a specific software application or print job, simplify the job, or print from a different application. If the message persists, contact the software vendor for assistance. If the message is not related to a specific file or software application, turn the printer off, disconnect the power cable and reseal the formatter, EIO cards, or memory DIMMs. Reconnect the power cable and turn the printer on. If the message persists, contact <a href="#">HP Customer Care</a> for assistance.</p>



## Correcting Output Quality Problems

Use the examples below to determine which output quality problem you are experiencing, then see the following tables to troubleshoot the problem.



**Note** The examples below depict letter-size paper that has passed through the printer long-edge first. (If the paper has passed through the printer short-edge first, lines and repeating defects will run vertically rather than horizontally.)



**Continued on next page.**



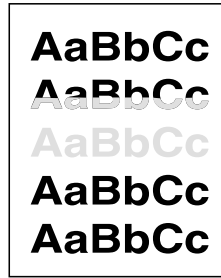

Light Print or Fade

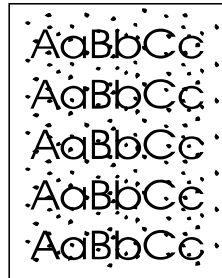

Toner Specks (front or back)

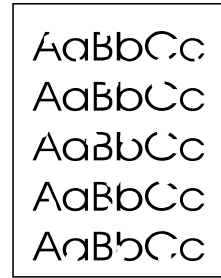

Dropouts

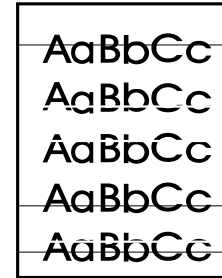

Lines

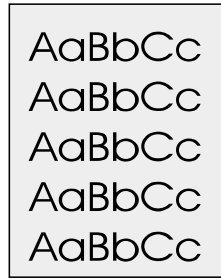

Gray Background

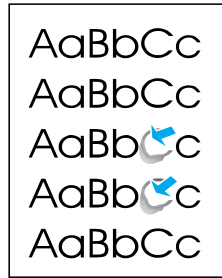

Toner Smear

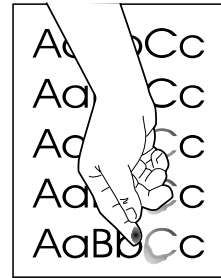

Loose Toner

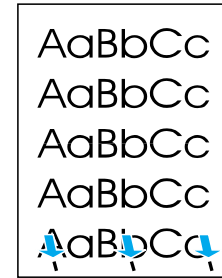

Repeating Defects

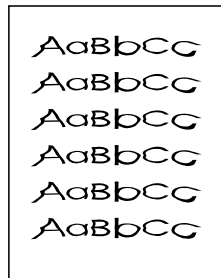

Misformed Characters

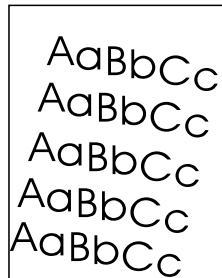

Page Skew

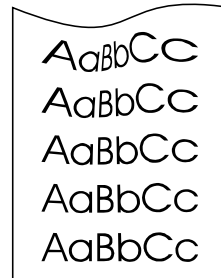

Curl or Wave

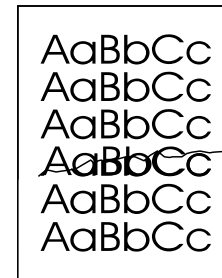

Wrinkles or Creases





Light Print or Fade	Specks	Dropouts	Lines	Gray Background	Toner Smear	Loose Toner	Repeating Defects	Misformed Characters	Page Skew	Curl or Wave	Wrinkles or Creases	<p><b>Troubleshooting Steps</b>                      (Follow the steps in the order they are listed.)</p>	
	✓		✓		✓	✓	✓				✓		1. Print a few more pages to see if the problem will correct itself.
	✓				✓	✓							2. Clean the inside of the printer or use the printer's cleaning page.
✓													3. Make sure EconoMode is off.
										✓	✓		4. Turn over the stack of paper in the tray. Also try rotating the paper 180 degrees.







Light Print or Fade	Specks	Dropouts	Lines	Gray Background	Toner Smear	Loose Toner	Repeating Defects	Misformed Characters	Page Skew	Curl or Wave	Wrinkles or Creases	Troubleshooting Steps (Follow the steps in the order they are listed.)
✓	✓	✓		✓	✓	✓		✓	✓	✓	✓	5. Check the paper (or other print media) type and quality.
✓		✓		✓						✓	✓	6. Check the environment (page <a href="#">329</a> ).
									✓		✓	7. Make sure paper is loaded correctly and guides are not too tight or too loose against the paper stack.
										✓	✓	8. Print to a different output bin.





Light Print or Fade	Specks	Dropouts	Lines	Gray Background	Toner Smear	Loose Toner	Repeating Defects	Misformed Characters	Page Skew	Curl or Wave	Wrinkles or Creases	Troubleshooting Steps (Follow the steps in the order they are listed.)
✓		✓		✓								9. Adjust the toner density setting.
					✓	✓						10. Change the fuser mode setting (page <a href="#">160</a> ). Check that the orange packing spacers are removed from the fusing area.
✓												11. Redistribute the toner in the toner cartridge (page <a href="#">195</a> ).
✓		✓	✓	✓	✓		✓	✓				12. Install a new HP toner cartridge. (See instructions provided with the toner cartridge.)



Light Print or Fade	Specks	Dropouts	Lines	Gray Background	Toner Smear	Loose Toner	Repeating Defects	Misformed Characters	Page Skew	Curl or Wave	Wrinkles or Creases	
✓	✓	✓	✓	✓	✓		✓					<p><b>Troubleshooting Steps</b></p> <p><b>(Follow the steps in the order they are listed.)</b></p>
✓	✓	✓	✓	✓	✓	✓	✓	✓	✓	✓	✓	<p>13. Order and install the Printer Maintenance Kit.</p>
✓	✓	✓	✓	✓	✓	✓	✓	✓	✓	✓	✓	<p>14. After trying all the steps suggested above, contact an HP-authorized service or support provider. (See the <a href="#">HP Customer Care</a> pages in the front of the user guide.)</p>



## Correcting Wrinkles on Envelopes

---

### Note

Once you have used this method to print envelopes, return the fuser levers to the down position for standard paper (media) types.

---

- 1 Open the left door. (If an optional output device is installed, first push it away from the printer to access the left door.)

---

### WARNING!

Avoid touching the adjacent fusing area. It may be HOT.

---

- 2 Locate and lift up the two “T” shaped levers as shown in figure 2.

Continued on next page.

1

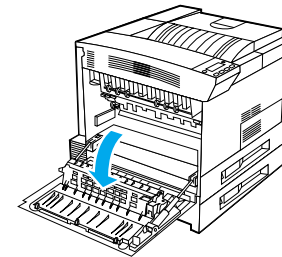

2

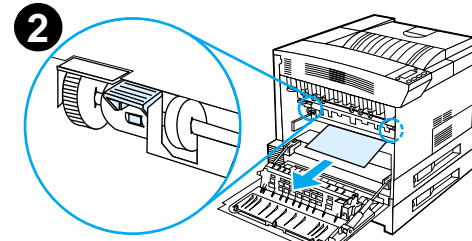

- 3 Close the left door.
- 4 Ensure that the Face-up Bin is selected when printing envelopes.

---

**CAUTION**

Failure to return levers in the down position for standard paper types may result in poor print quality.

---

When you are done printing on envelopes, make sure you return the fuser levers to the down position.

3

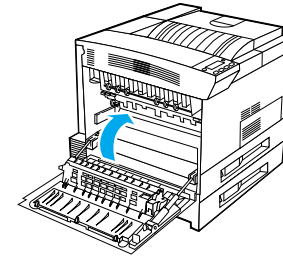

## Determining Printer Problems

### Troubleshooting Checklist

- [Printer Does Not Turn On](#)
- [Blank or Garbled Control Panel Display](#)
- [Printer Cannot Print Configuration Page](#)
- [Print Job Does Not Print](#)
- [Computer, Network, or I/O Port Problems](#)
- [Print Speed is Too Slow](#)
- [Printing is Incomplete or Incorrect](#)
- [Printer Ignores Font, Format, or Tray/Bin Selection](#)
- [Print Job Does Not Print on Both Sides of Paper](#)
- [Print Job on Custom Paper Does Not Print Correctly](#)
- [Problems with Tray 1](#)
- [Problems with Trays 2, 3, and the Optional 2 x 500-sheet Input Tray \(Trays 4 and 5\)](#)

Continued on next page.



- [Problems with the Optional 2000-sheet Input Tray \(Tray 4\)](#)
- [Problems with the Optional 8-bin Mailbox](#)
- [Problems with the Optional 7-bin Tabletop Mailbox](#)
- [Problems with the Optional Duplex Printing Accessory](#)
- [Problems with the Optional Envelope Feeder](#)
- [Printer Hard Disk](#)
- [PS Troubleshooting](#)
- [HP Fast InfraRed Connect Problems](#)
- [Macintosh Problem Solving](#)



**Note**

For more information on an optional HP output device, see the user guide that came with the device.



## Printer Problems



### Printer Does Not Turn On

Situation	Solution
Printer is not plugged in.	Plug the AC power cord firmly into the grounded power receptacle and into the printer. (Be sure the power source is energized.)
Printer voltage is not correct.	Make sure line voltage is in the correct range. (See the product label next to the power receptacle on the back of the printer for voltage requirements.)



### Blank or Garbled Control Panel Display

Situation	Solution
Printer is not turned on.	Put the printer's power switch in the on position.
Printer is turned on but internal fans are not running.	Make sure the line voltage is correct for the printer's power configuration. (See the plate next to the power receptacle on the back of your printer for voltage requirements.) If you are using a power strip and its voltage is not within specification, plug the printer directly into the power receptacle.



### Correcting Output Quality Problems



**Blank or Garbled Control Panel Display (continued)**

Situation	Solution
Display is blank and internal fans are not running.	Make sure that the printer power is on. Press all the keys to see if one is stuck; contact your HP service representative if this does not work.
Printer display is in the wrong language or displays unfamiliar characters.	Reconfigure the control panel display language. See the getting started guide, or press and hold <b>SELECT</b> while simultaneously pushing the power switch ON. Hold <b>SELECT</b> until <b>SELECT LANGUAGE</b> appears, then release <b>SELECT</b> . Use the <b>VALUE -</b> and <b>VALUE +</b> keys to select the desired language. Press <b>SELECT</b> to save your selection. Press <b>Go</b> . The control panel display will indicate the printer is ready to use. If the new language does not appear in the display, you may not have pressed <b>SELECT</b> to save your new selection.



**Printer Cannot Print Configuration Page**

Situation	Solution
Correct size of paper is not loaded.	Check paper trays to be sure the correct sizes are loaded (Letter or A4). Also, check that guides are set correctly.
Toner cartridge sealing tape is not removed.	Remove sealing tape from toner cartridge. See the printer's getting started guide or the installation guide that came with the toner cartridge.
Paper tray is out of paper.	Load paper, see instructions starting on page <a href="#">89</a> .
A printer cover is open.	Firmly close the printer top cover and all doors (left, front, and right).
Paper is jammed in the printer.	Check for paper jams, see instructions starting on page <a href="#">202</a> .
Messages appear in the display.	See <a href="#">Understanding Printer Messages</a> starting on page <a href="#">226</a> .



## Software, Computer, and Printer Interface Problems



### Print Job Does Not Print

Situation	Solution
Printer is off or not connected to an active power source.	Make sure the printer is on and that all power cables are firmly plugged into both the printer components and an active power source.
Printer is offline.	Press <b>Go</b> to put the printer online. The printer control panel should display <code>READY</code> and the Ready light should be lit.
Port is configured and working properly.	<ul style="list-style-type: none"><li>● Make sure the print job is being sent to the correct port (LPT1 or network printer port, for example).</li><li>● Connect another printer to current port and print.</li></ul>



**Print Job Does Not Print (continued)**

Situation	Solution
Printer is online but not receiving data (the Data light does not blink).	<ul style="list-style-type: none"><li>● Check for loose I/O cable connections at the printer and computer or network port.</li><li>● Try your I/O cable on a system that you know works.</li><li>● Check that the correct interface cable was selected and securely connected to both the printer and the computer. If the cable is not correctly configured, see the getting started guide for configuration information.</li><li>● If connected to a network, print a JetDirect configuration page to check for interface or network problems (page <a href="#">314</a>).</li></ul>
Printer displays a message.	See <a href="#">Understanding Printer Messages</a> starting on page <a href="#">226</a> for printer messages and recommended actions.



**Print Job Does Not Print (continued)**

Situation	Solution
Data from a previous print job is still in the printer's buffer.	<ul style="list-style-type: none"><li>● Make sure that you are using the correct printer driver.</li><li>● Complex print job may still be processing.</li><li>● Make sure the printer is online. Make sure control panel reads processing job.</li><li>● Open the top cover. Pull out the toner cartridge and check for paper. Reseat the toner cartridge.</li><li>● Open trays 2 and 3. Make sure that the appropriate paper is inserted. (For more information on paper specifications, see page <a href="#">392</a>.) Close the trays.</li></ul>
Last page did not print and the Data light is on.	<ul style="list-style-type: none"><li>● Make sure that you are using the correct printer driver.</li><li>● Complex print job may still be processing.</li><li>● Make sure the printer is online. Make sure the control panel reads <code>PROCESSING JOB</code>.</li><li>● Open the top cover. Pull out the toner cartridge and check for paper. Reseat the toner cartridge.</li><li>● Open trays 2 and 3. Make sure that the appropriate paper is inserted. (For more information on paper specifications, see page <a href="#">392</a>.) Close the trays.</li></ul>



**Print Job Does Not Print (continued)****Situation****Solution**

Data light is flashing but nothing prints.

- Make sure that you are using the correct printer driver.
- Complex print job may still be processing.
- Make sure the printer is online. Make sure control panel reads processing job.
- Open the top cover. Pull out the toner cartridge and check for paper. Reseat the toner cartridge.
- Open trays 2 and 3. Make sure that the appropriate paper is inserted. (For more information on paper specifications, see page [392](#).) Close the trays.

**Print Speed is Too Slow****Situation****Solution**

First page takes much longer to print than following pages.

- Make sure that the printer displays `READY`.
- Set the PowerSave feature for a longer time period. (See [Configuration Page](#) on page [314](#).) If a page takes longer to print due to complex formatting commands, changing the PowerSave setting might not improve print speed. You might want to simplify the page.



***Print Speed is Too Slow (continued)*****Situation****Solution**

Printer is usually slow to respond.

- Printer speed is highly dependent on how your software application is set up, which printer driver you are using, and how much traffic is on the network. See the getting started guide for configuration information.
- You might need to add more memory (page [471](#)).

***Printing is Incomplete or Incorrect*****Situation****Solution**

Blank pages print.

- Turn the printer off and then back on.
- Make sure the toner cartridge is installed properly.
- Make sure the toner cartridge sealing tape has been removed. Firmly pull the tab straight out from the cartridge to remove the entire length of tape. Avoid touching any black toner on the tape.



*Printing is Incomplete or Incorrect (continued)*

Situation	Solution
Garbled pages print, there are overprints, or only a portion of a page prints.	<ul style="list-style-type: none"> <li>● Make sure that your software application is configured for the correct printer.</li> <li>● Replace the printer interface (I/O) cable with a cable you know works to see if the cable is defective.</li> <li>● Your parallel printer cable might be defective. Use a high-quality cable; see page <a href="#">48</a> for an HP cable part number.</li> <li>● Set the PERSONALITY item in the Configuration Menu to AUTO (page <a href="#">446</a>). The printer may have been set to PCL and a PS job was sent to the printer, or vice versa.</li> <li>● Data sent to the printer may be corrupt. Try sending another file to see if it prints.</li> </ul>
The job was not duplexed.	<ul style="list-style-type: none"> <li>● Turn the printer off. Make sure that the duplexer is properly installed. Turn the printer on.</li> <li>● Make sure that you are using the correct paper size (page <a href="#">396</a>).</li> <li>● Make sure that you are following the guidelines for printing on both sides of the paper (see <a href="#">118</a>).</li> </ul>





*Printing is Incomplete or Incorrect (continued)*

---



**Situation**

**Solution**

---

Data is missing, but there are no printer messages.

- Check your software application to be sure the print file contains no errors.
- Check your cable to make sure that it is securely connected to both the printer and the computer.
- Your parallel printer cable may be defective. Use a high-quality cable; see page [48](#) for an HP cable part number.



**Printing is Incomplete or Incorrect (continued)**

Situation	Solution
Printing stops in the middle of the job.	<ul style="list-style-type: none"><li>● Check the control panel display for an error message.</li><li>● If you are on a network, make sure the computer is correctly configured and there is not a network problem (see your network administrator).</li><li>● Check the line voltage to make sure that it is steady and within printer specifications. (See page <a href="#">418</a>.) Turn the printer off and then back on.</li><li>● Check the time-out setting in your network application. You might need to increase it.</li><li>● If you are trying to copy a file to the printer from the DOS prompt, use the copy command <code>COPY [filename] LPTn /B</code> printer port, such as LPT1 (where <code>n</code> is the port number).</li></ul>
	<p><b>Note</b> To output the page, you might have to send a form feed command from the computer.</p>



**Printer Ignores Font, Format, or Tray/Bin Selection****Situation****Solution**

Printer prints wrong fonts or formats.

- The font is not present in the printer and must be downloaded from your software application or the proper font DIMM must be installed. Check your software application to make sure the correct printer driver has been installed and configured. To verify that the font you want is available, print a font list (page [318](#)).
- Your software selected a substitute font for one that is not available in the printer. (See your software application manual for more information on font selection.)



**Printer Ignores Font, Format, or Tray/Bin Selection (continued)**

Situation	Solution
Printer draws paper from the wrong tray.	<ul style="list-style-type: none"> <li>● Be sure your software application is selecting the correct paper size or type.</li> <li>● Make sure that the driver for your software application is correctly installed, configured, and capable of requesting the desired paper size and type.</li> <li>● The size of paper requested is not loaded in the tray selected. The printer draws paper from the next default tray that contains the correct size. Load the correct paper into the tray and make sure the tray is adjusted correctly. Load the tray with enough paper to complete the print job.</li> <li>● If you selected the 2000-sheet Input Tray (Tray 4) or the 2 x 500-sheet Input Tray (Tray 4 or 5) and did not turn the printer off when installing it, the printer does not recognize it and draws paper from the next default tray source. (Turn the printer off, then back on, and the printer will recognize the tray.)</li> </ul>
Control panel settings, such as RESOLUTION or ORIENTATION, do not work or are ignored.	Software commands override control panel settings. (See page <a href="#">58</a> for information about how your software works with control panel settings.)

**Correcting Output Quality Problems**

**Printer Ignores Font, Format, or Tray/Bin Selection (continued)**

Situation	Solution
Job went to a different bin than was expected.	The wrong size or type of paper was used for the job. (See page <a href="#">392</a> for supported paper sizes.)
Job prints on the wrong side of the paper.	<ul style="list-style-type: none"><li>● Make sure you have loaded the paper correctly. (Starting on page <a href="#">89</a>.)</li><li>● If you are printing one-sided copies, load paper into Tray 1 with the side to be printed facing up. Load paper into Trays 2, 3, and the 2000-sheet Input Tray with the side to be printed facing down.</li><li>● If you are printing two-sided copies, load paper into Tray 1 with the first side to be printed facing down. Load paper into Trays 2, 3, and the 2000-sheet Input Tray with the first side to be printed facing up.</li></ul>

***Print Job Does Not Print on Both Sides of Paper***

---



**Situation**

**Solution**

---

See page [293](#) for problems with the optional duplex printing accessory.

---



***Print Job on Custom Paper Does Not Print Correctly***

---

**Situation**

**Solution**

---

The control panel and driver are not set to the same paper size.

Make sure that the custom paper size defined from the control panel and the custom paper size defined in the driver are the same.

---



**Problems with Tray 1**

Situation	Solution
Cannot clear MANUALLY FEED [TYPE] [SIZE] message.	<ul style="list-style-type: none"> <li>● A previous print job may still be in the printer's buffer.</li> <li>● Make sure that Tray 1 has the correct paper size loaded. For more information on paper specifications, see page <a href="#">390</a>.</li> </ul>
Cannot print from Tray 1.	Make sure to select Manual Feed or Tray 1 through your software application and the size and type for which the tray is configured. For Manual Feed, wait for the printer to request the manual feed before loading the paper.
Paper is loaded into Tray 1 and the control panel displays a load or manual feed message.	Load the correct paper into the tray. See <a href="#">Loading Tray 1</a> on page <a href="#">89</a> . If the correct paper is already loaded, press <a href="#">Go</a> .
Paper is not going to the correct output bin.	<ul style="list-style-type: none"> <li>● Verify that the correct output bin is selected in the printer driver. For more information on changing printer driver settings, see the online help.</li> <li>● The paper does not meet the specifications for the output bin. See page <a href="#">392</a> for more information on paper specifications.</li> </ul>

**Correcting Output Quality Problems**

### *Problems with Trays 2, 3, and the Optional 2 x 500-sheet Input Tray (Trays 4 and 5)*



Situation	Solution
General operation problems.	For general paper operation information, see Chapter 2, <a href="#">Printing Tasks</a> .
Paper jams and paper feeding problems.	<ul style="list-style-type: none"> <li>● See <a href="#">Clearing Trays 2 and 3</a> or <a href="#">Clearing the Optional 2 x 500-sheet Input Trays (4 and 5)</a> earlier in this Chapter.</li> <li>● Ensure that paper specifications are within recommended range (page <a href="#">390</a>).</li> <li>● Make sure the paper guides are adjusted properly and are not skewed (page <a href="#">93</a>).</li> <li>● Perform preventive maintenance if requested by the printer.</li> </ul>
Cannot access Trays 2, 3, or the Optional 2 x 500-sheet Input Tray (Trays 4 and 5).	<ul style="list-style-type: none"> <li>● The appropriate paper size and type must be selected from the software application for the paper size loaded.</li> <li>● Adjust the tray correctly for the paper size loaded. Check the Paper Handling Menu for correct type of paper available (page <a href="#">427</a>).</li> </ul>





### *Problems with Trays 2, 3, and the Optional 2 x 500-sheet Input Tray (Trays 4 and 5) (continued)*



Situation	Solution
TRAY LOAD x [TYPE] [SIZE] paper size message.	Load the requested paper size or press <b>SELECT</b> to print on a size already loaded. The printer has a job in the buffer and is waiting to print on the correct paper size.  Set the paper type in the control panel (page <a href="#">420</a> ).



### *Problems with the Optional 2000-sheet Input Tray (Tray 4)*

Situation	Solution
Paper size adjustment and installation.	See “Paper Specifications” on page <a href="#">390</a> and “Loading the Optional 2000-sheet Input Tray (Tray 4)” on page <a href="#">98</a> for more information on paper size adjustment and installation.



**Problems with the Optional 2000-sheet Input Tray (Tray 4) (continued)****Situation****Solution**

Paper jams and paper feeding problems.

- See page [209](#) for instructions.
- Make sure that paper specifications are within the recommended range (page [390](#)).
- Verify that the paper type configured in the printer control panel for Tray 4 matches the paper loaded in Tray 4 (page [98](#)).
- A tray might have been pulled out during printing.
- Check cables and connectors between the tray and the printer. See page [292](#) for cabling configurations.
- Remove and reconnect the power cord if it is not firmly plugged into the computer.
- Make sure trays are correctly loaded.
- Make sure the paper guides are adjusted properly and not skewed (page [98](#)).
- Perform preventive maintenance if requested by the printer.



**Problems with the Optional 2000-sheet Input Tray (Tray 4) (continued)**

Situation	Solution
Tray 4 will not power on.	<ul style="list-style-type: none"><li>● The power cord is not firmly plugged into both the printer and the power receptacle. Remove and reconnect the power cord.</li><li>● Check cables and connectors between the tray and the printer. See page <a href="#">292</a> for cabling configurations.</li></ul>
Cannot access Tray 4.	Make sure that the paper tray guides are adjusted correctly for the paper size you are using (page <a href="#">98</a> ).
Printer does not recognize Tray 4.	<ul style="list-style-type: none"><li>● Make sure the Optional 2000-sheet Input Tray has been configured in the printer driver. See page <a href="#">62</a> for more information on accessing the printer driver.</li><li>● Turn the printer off and then back on.</li><li>● Make sure that the C-link cable from the Tray 4 base is plugged into the printer. If not, turn the printer off and plug the cable into the printer, then turn the printer back on. See page <a href="#">292</a> for cabling configurations.</li><li>● Make sure the power cord is plugged into Tray 4. See page <a href="#">292</a> for cabling configurations.</li><li>● If the printer still does not recognize Tray 4, contact your dealer or authorized HP service provider.</li></ul>



**Problems with the Optional 5-bin Mailbox with Stapler**

Situation	Solution
The job was not stapled.	<p data-bbox="674 386 1776 467">Jobs sent to the stapler might not be stapled for one or more of the following reasons:</p> <ul data-bbox="674 500 1776 1281" style="list-style-type: none"><li data-bbox="674 500 1776 581">● The stapler is out of staples and <code>AUTO CONTINUE</code> is set to <code>ON</code>.</li><li data-bbox="674 605 1776 643">● The wrong size or type of paper was used for the job.</li><li data-bbox="674 667 1776 748">● More than 20 pages were sent to the stapler, exceeding its capacity.</li><li data-bbox="674 773 1776 854">● The stapler has bent or broken staples in the stapler head. (See page <a href="#">222</a>.)</li><li data-bbox="674 878 1776 959">● A staple jam was recently cleared (up to 2 following jobs might not be stapled).</li><li data-bbox="674 984 1776 1114">● The job was sent to a bin other than the stapler bin because the wrong size or type of paper was used for the job.</li><li data-bbox="674 1138 1776 1175">● One-page jobs will not be stapled.</li><li data-bbox="674 1200 1776 1281">● The interface cable between the mailbox and the stapler unit may be defective or not connected properly.</li></ul>



**Problems with the Optional 5-bin Mailbox with Stapler (continued)**

Situation	Solution
General repeated stapler jam problems.	<ul style="list-style-type: none"><li>● Check to see that the job to be stapled is less than 2 mm thick.</li><li>● Stapler may have some trapped staple wires that are obstructing the magazine. Remove loose staples and paper dust from the inside of the stapler (page <a href="#">222</a>).</li></ul>
Printer does not recognize the 5-bin Mailbox with Stapler.	<ul style="list-style-type: none"><li>● Make sure that the 5-bin Mailbox with Stapler has been configured in the printer driver. See page <a href="#">62</a> for more information on accessing the printer driver.</li><li>● Make sure that the cable from the 5-bin Mailbox with Stapler is plugged into the printer C-link connector. If not, turn the printer off and plug the cable into the C-link connector, then turn the printer back on. See page <a href="#">292</a> for cabling configurations.</li><li>● Make sure that all bins are properly installed.</li><li>● If the printer still does not recognize the 5-bin Mailbox with Stapler, contact your dealer or authorized HP service provider.</li></ul>

**Problems with the Optional 5-bin Mailbox with Stapler (continued)**

<b>Situation</b>	<b>Solution</b>
Printer does not recognize stapler.	<ul style="list-style-type: none"><li>● Check the cable between the Mailbox and the stapler. Make sure it is properly connected at both ends. See page <a href="#">292</a> for cabling configurations.</li></ul>
The 5-bin Mailbox with Stapler will not power on.	<ul style="list-style-type: none"><li>● Make sure that the power cord is firmly plugged into both the 5-bin Mailbox with Stapler and the power receptacle. Remove and reconnect the power cord.</li><li>● Make sure that the cable from the 5-bin Mailbox with Stapler is plugged into the printer C-link connector. If not, turn the printer off, plug the cable into the C-link connector, then turn the printer back on. See page <a href="#">292</a> for cabling configurations.</li><li>● Verify that the cables are firmly attached to the printer.</li></ul>
Paper jams and paper feeding problems.	<ul style="list-style-type: none"><li>● Make sure that you are using the supported paper weights (page <a href="#">392</a>).</li><li>● Do not pull paper out of the bins while printing.</li><li>● Check cables and connectors between the printer and the 5-bin Mailbox with Stapler. See page <a href="#">292</a> for cabling configurations.</li></ul>



**Problems with the Optional 5-bin Mailbox with Stapler (continued)****Situation****Solution**

Paper is not going to the correct output bin.

- Verify that the correct output bin is selected in the printer driver. For more information on changing printer driver settings, see the online help.
- The paper does not meet the specifications for the output bin. See page [392](#) for more information on paper specifications.
- If you are trying to send print jobs to an optional multibin mailbox, verify that the multibin mailbox has been installed on the printer and in the printer driver. Also verify the multibin mailbox mode, which will affect the print job destination.



**Problems with the Optional 8-bin Mailbox**

Situation	Solution
Printer does not recognize the Mailbox.	<ul style="list-style-type: none"> <li>● Make sure that the 8-bin Mailbox has been configured in the printer driver. See page <a href="#">62</a> for more information on accessing the printer driver.</li> <li>● Make sure that the cable from the 8-bin Mailbox is plugged into the printer C-link connector. If not, turn the printer off, plug the cable into the C-link connector, then turn the printer back on. See page <a href="#">292</a> for cabling configurations.</li> <li>● Make sure that all bins are properly installed.</li> <li>● If the printer still does not recognize the 8-bin Mailbox, contact your dealer or authorized HP service provider.</li> </ul>
Paper jams and paper feeding problems.	<ul style="list-style-type: none"> <li>● Make sure that you are using the supported paper weights (page <a href="#">392</a>).</li> <li>● Do not pull paper out of the bins while printing.</li> <li>● Check cables and connectors between the printer and the mailbox. See page <a href="#">292</a> for cabling configurations.</li> <li>● Repeated paper jams in the multibin mailbox area might indicate that the printer and multibin mailbox are set up on an uneven floor. Move the printer to a level location.</li> </ul>





**Problems with the Optional 8-bin Mailbox (continued)**

Situation	Solution
Paper is not going to the correct output bin.	<ul style="list-style-type: none"><li>● Verify that the correct output bin is selected in the printer driver. For more information on changing printer driver settings, see the online help.</li><li>● The paper does not meet the specifications for the output bin. See page <a href="#">392</a> for more information on paper specifications.</li><li>● If you are trying to send print jobs to an optional multibin mailbox, verify that the multibin mailbox has been installed on the printer and in the printer driver. Also verify the multibin mailbox mode, which will affect the print job destination.</li></ul>
The multibin mailbox will not power on.	<ul style="list-style-type: none"><li>● Verify that the power cord is firmly plugged into both the multibin mailbox and the power receptacle. Remove and reconnect the power cord.</li><li>● Make sure that the cable from the multibin mailbox is plugged into the printer C-link connector. If not, turn the printer off, plug the cable into the C-link connector, then turn the printer back on. See page <a href="#">292</a> for cabling configurations.</li><li>● Verify that the cables are firmly attached to the printer.</li></ul>



**Problems with the Optional 7-bin Tabletop Mailbox**

Situation	Solution
Printer does not recognize the mailbox.	<ul style="list-style-type: none"> <li>● Make sure that the 7-bin Mailbox has been configured in the printer driver. See page <a href="#">62</a> for more information on accessing the printer driver.</li> <li>● Make sure that the C-link cable is properly connected. See page <a href="#">292</a> for cabling configurations.</li> <li>● Make sure that all bins are properly installed.</li> <li>● If the printer still does not recognize the 7-bin Mailbox, contact your dealer or authorized HP service provider.</li> </ul>
Paper jams and paper feeding problems.	<ul style="list-style-type: none"> <li>● Make sure that you are using the supported paper weights (page <a href="#">392</a>).</li> <li>● Do not pull paper out of the bins while printing.</li> <li>● Check cables and connectors between the printer and the mailbox. See page <a href="#">292</a> for cabling configurations.</li> <li>● Repeated paper jams in the multibin mailbox area might indicate that the printer and multibin mailbox are set up on an uneven floor. Move the printer to a level location.</li> </ul>



**Problems with the Optional 7-bin Tabletop Mailbox (continued)**

Situation	Solution
Paper is not going to the correct output bin.	<ul style="list-style-type: none"><li>● Verify that the correct output bin is selected in the printer driver. For more information on changing printer driver settings, see the online help.</li><li>● The paper does not meet the specifications for the output bin. See page <a href="#">392</a> for more information on paper specifications.</li><li>● If you are trying to send print jobs to an optional multibin mailbox, verify that the multibin mailbox has been installed on the printer and in the printer driver. Also verify the multibin mailbox mode, which will affect the print job destination.</li></ul>
The multibin mailbox will not power on.	<ul style="list-style-type: none"><li>● Verify that the power cord is firmly plugged into both the multibin mailbox and the power receptacle. Remove and reconnect the power cord.</li><li>● Make sure that the C-link cable is properly connected. See page <a href="#">292</a> for cabling configurations.</li><li>● Verify that the cables are firmly attached to the printer.</li></ul>



# Cabling Configurations

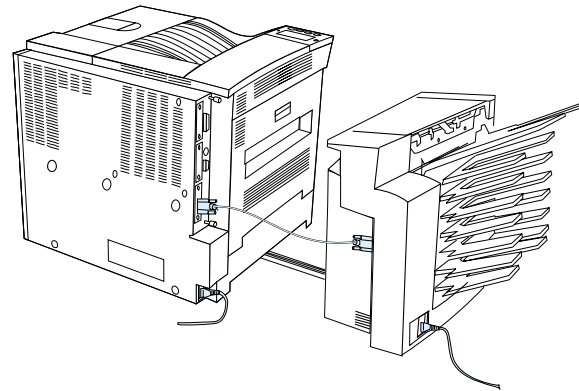
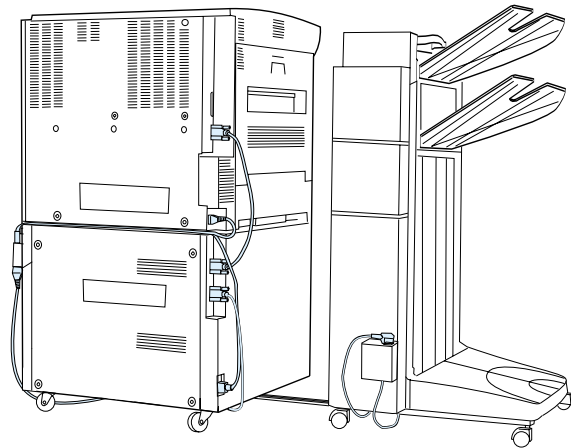
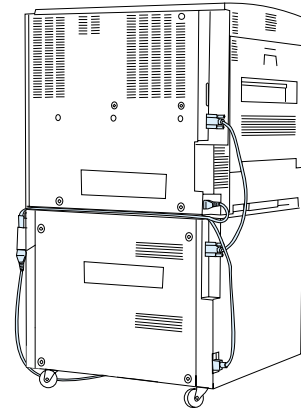
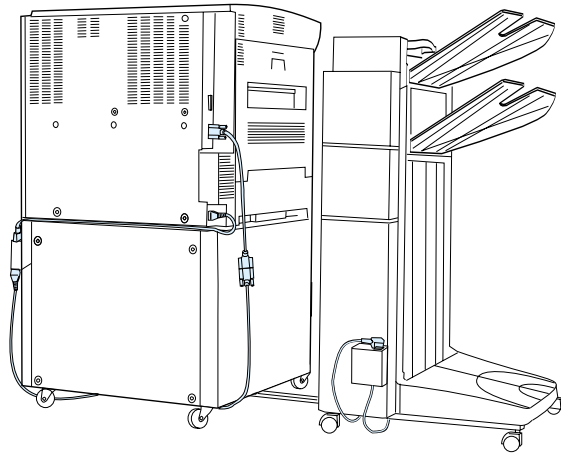

**Problems with the Optional Duplex Printing Accessory**

Situation	Solution
Printer does not recognize the duplexer.	<ul style="list-style-type: none"> <li>● Print a configuration page (page <a href="#">314</a>) to ensure that the duplexer is installed.</li> <li>● Turn the printer off. Remove and re-install the unit. Turn the printer on.</li> <li>● Make sure that the duplexer has been configured in the printer driver.</li> </ul>
Job did not duplex.	<ul style="list-style-type: none"> <li>● Print a configuration page (page <a href="#">314</a>) to ensure that the duplexer is installed.</li> <li>● Make sure the duplexer has been configured in the printer driver.</li> <li>● Make sure that the software is not overriding the printer driver setting.</li> </ul>
Duplexer jams.	<ul style="list-style-type: none"> <li>● Make sure that you are using the supported paper weights and sizes (page <a href="#">392</a>).</li> </ul>
Driver may not be set up to print on both sides of the paper.	Make sure that the option to print on both sides of the paper is properly configured in the driver.

**Correcting Output Quality Problems**

**Problems with the Optional Duplex Printing Accessory (continued)**

<b>Situation</b>	<b>Solution</b>
The file you are trying to print may not have the option to print on both sides of the paper turned on.	Make sure that the option to print on both sides of the paper is configured in the driver.
Type has been specified as labels, transparencies, or envelopes.	<ul style="list-style-type: none"><li>● Make sure that the media type can be printed on both sides (see page <a href="#">118</a>).</li><li>● Change the media type to the proper media type for printing on both sides.</li></ul>
Cannot print on both sides of custom-size paper.	If a custom tray is installed, the printer will not duplex custom-size paper from Tray 1 or the custom paper tray.



**Problems with the Optional Envelope Feeder**

Situation	Solution
Envelope jams and envelope feeding problems.	<ul style="list-style-type: none"> <li>● Make sure the envelopes are within the specifications listed on page <a href="#">406</a>.</li> <li>● Make sure the envelopes are properly loaded.</li> <li>● Make sure the envelope weight on the feeder is down.</li> <li>● Make sure the Optional Envelope Feeder extension is fully pulled out.</li> <li>● Make sure that the fuser levers are properly set (page <a href="#">128</a>).</li> </ul>
Multiple envelopes feed into the printer.	The first (bottom) envelope to be fed must be closer to the pick up roller than the others.
No envelopes are fed into the printer.	<ul style="list-style-type: none"> <li>● Make sure you are not overloading the envelope feeder.</li> <li>● When loading the envelopes, be sure to push them all the way down to touch the rollers.</li> </ul>



**Problems with the Optional Envelope Feeder (continued)**



Situation	Solution
Printer does not recognize the Optional Envelope Feeder.	<ul style="list-style-type: none"> <li>● Turn the printer off, remove and re-install the Optional Envelope Feeder, then turn the printer back on.</li> <li>● Make sure the Optional Envelope Feeder has been configured in the printer driver. See page <a href="#">66</a> for more information on accessing the printer driver.</li> </ul>



**Printer Hard Disk**

Situation	Solution
Printer does not recognize the hard disk.	Turn the printer off and verify that the hard disk is inserted correctly and is securely fastened.
Disk is not initialized. DISK x NOT INITIALIZED	Use the Windows-based HP LaserJet Resource Manager or the Macintosh-based HP LaserJet Utility to initialize the disk.
Disk failure. EIO x DISK NOT FUNCTIONING	Turn the printer off and make sure that the EIO disk is inserted correctly and securely fastened. If the control panel message continues to be displayed, the disk drive needs to be replaced.



**Correcting Output Quality Problems**



**Printer Hard Disk (continued)**

Situation	Solution
Disk is write protected. DISK IS WRITE PROTECTED	Fonts and forms cannot be stored on the disk when the disk is write protected. Use the Windows-based HP LaserJet Resource Manager or the Macintosh-based HP LaserJet Utility to remove the write protection from the disk.
Attempted to use a disk-resident font, but the printout substituted a different font.	If you are using PCL, print the PCL Font Page, and verify that the font is on the disk. If you are using PS, print the PS Font Page and make sure that the font is on the disk. If the font is not on the disk, use the HP LaserJet Resource Manager or the Macintosh-based HP LaserJet Utility to download the font.

**PS Troubleshooting**

Situation	Solution
A text listing of PS commands prints instead of your PS printing job.	The control panel PERSONALITY=AUTO setting may have been confused by a nonstandard PS code. Check the PERSONALITY setting to see if it is set to PS or PCL. If it is set to PCL, set it to PERSONALITY=AUTO. If it is set to AUTO, set it to PS for this print job only. When the job has printed, return the setting to AUTO.
The job prints in Courier (the printer's default font) instead of the font you requested.	<ul style="list-style-type: none"> <li>● The requested typeface is not available in the printer or is not present on the disk. Use a font download utility to download the desired font.</li> <li>● Fonts downloaded to memory are lost when the printer is turned off. They are also lost if Resource Saving is not used and a personality switch is performed to print a PCL job. Disk fonts are not affected by PCL jobs or by turning the printer off.</li> <li>● Print a PS Font Page to verify that the font is available. If a disk font appears to be missing, it may be because a software utility was used to delete the font, because the disk was re-initialized, or because the disk drive is not installed correctly. Print a configuration page to verify that the disk drive is installed and functioning correctly.</li> <li>● Print a Disk Directory to help identify available fonts.</li> </ul>



*PS Troubleshooting (continued)*

Situation	Solution
A page prints with clipped margins.	If the page margins are clipped, you may have to print the page at 300-dpi resolution or install more memory. Also try turning off Resource Saving and I/O Buffering.
A page fails to print.	Set <code>PRINT PS ERRORS=ON</code> , and then send the job again to print a PS error page. If this does not identify the problem, try turning off Resource Saving and I/O Buffering or installing more memory. (See page <a href="#">318</a> for more information about PS printing.)
A PS error page prints.	<ul style="list-style-type: none"> <li>● Make sure the print job is a PS job.</li> <li>● Check to see whether your software expected you to send a setup or PS header file to the printer.</li> <li>● Check the printer setup in your software application to make sure that the printer is selected.</li> <li>● Check cable connections to ensure that they are secure.</li> <li>● Reduce the complexity of the graphic.</li> <li>● Add available memory by turning on Resource Saving.</li> </ul>



**Computer, Network, or I/O Port Problems**

<b>Situation</b>	<b>Solution</b>
Printer Interface problems.	Print a configuration page from the printer's control panel to verify that the interface configurations shown on the printout match those on the host computer. (See page <a href="#">314</a> to print a configuration page.)
Computer software problem.	Check that your computer is working correctly by printing from a software application you know works or by printing a plain text file to see if the problem is with your software application or printer driver. (For example, <code>C:\dir&gt;LPTn</code> where <code>n</code> is the number of the computer port the printer is connected to, for example <code>LPT1</code> .) To output the page, you may have to send a form feed command from your computer.
Software is selecting the wrong port.	Check your operating system's port settings to be sure the print job is being sent to the correct port (for example, <code>LPT1</code> ).
Printer port problem.	Check that your computer's port is configured and working properly. One way to check this is to connect another printer to that port on your computer and print an application you know works.

**Correcting Output Quality Problems**

*Computer, Network, or I/O Port Problems (continued)*

Situation	Solution
Network or shared printer problems.	Check for network or shared printer problems by connecting your computer directly to the printer and printing from an application you know works. If you suspect network problems, check with your network administrator or consult the network documentation that came with your printer network cards.
Computer displays DOS messages such as: Write Fault Error Writing Device LPTn: Abort, Retry, Ignore?	<ul style="list-style-type: none"> <li>● Add a Mode command to your computer's AUTOEXEC.BAT file for the parallel port. It should be inserted immediately following the PATH statement:  For DOS versions below 4.0, add: <code>MODE LPT1: , , P</code>  For DOS versions 4.0 and above, add: <code>MODE LPT1: , , B</code></li> <li>● The I/O cable might be faulty; see <a href="#">Printing is Incomplete or Incorrect</a> on page <a href="#">271</a>.</li> </ul>



**HP Fast InfraRed Connect Problems**

---

**Situation****Solution**

---

FIR port status indicator does not light up.

- Make sure that the printer is in **READY** mode and that the FIR port you are printing from is IRDA-compliant and within the range of operation described in [Printing a Job](#) on page [182](#).
- Make sure that the HP Fast InfraRed Connect is properly connected to the printer.
- Run the printer Self Test. Make sure that FIR POD (IRDA Compliant) is printed under Installed Personalities and Options.



**HP Fast InfraRed Connect Problems (continued)****Situation****Solution**

Connection cannot be established or seems to take longer than usual.

- Use a device that is IRDA-compliant; look for an IRDA symbol on the device or see the computer's user guide for IRDA specifications.
- Make sure that the operating system on your computer includes an FIR driver and your application uses a compatible driver. (Note that complex pages take longer to print.)
- Position the HP Fast InfraRed Connect within the range of operation described in [Printing a Job](#) on page 182, and make sure that no object is blocking the connection. (This object could be a hand, paper, books, or even bright light.)
- Make sure that the two FIR ports are clean (free from dirt and grease).
- Bright light of any kind (sunlight, incandescent light, fluorescent light, or light from an infrared remote control, such as those used for TVs and VCRs) shining directly into one of the FIR ports might cause interference. Make sure that no bright light is shining directly into either FIR port.
- Position the portable device closer to the FIR port on the printer.

**HP Fast InfraRed Connect Problems (continued)**

<b>Situation</b>	<b>Solution</b>
The printer prints only part of a page or document.	The connection has been broken during transmission. If you move the portable device during transmission, the connection can be broken. IRDA-compliant devices are designed to recover from temporary connection interruptions. You have up to 40 seconds to re-establish the connection (depending on the portable device being used).
The print job has been properly sent, but the printer will not print.	If the connection is broken before the entire print job has been transmitted to the printer (printing has not yet started), the printer may not print any of the job. Press <b>CANCEL JOB</b> to clear the printer's memory. Then, reposition the portable device within the range of operation described in <a href="#">Printing a Job</a> on page <a href="#">182</a> , and print the job again.
The FIR status indicator turns off during transmission.	The connection might have been broken. Press <b>CANCEL JOB</b> to clear the printer's memory. Then, reposition the portable device within the range of operation described in <a href="#">Printing a Job</a> on page <a href="#">182</a> , and print the job again.
PS print job will not print.	Check the configuration in the PostScript Tab of Windows: check that Protocol is set to AppleTalk and Binary Data is not selected.





**Macintosh Problem Solving**

Situation	Solution
The Macintosh computer is not communicating with the printer.	<ul style="list-style-type: none"> <li>● Make sure the printer's control panel displays <b>READY</b>.</li> <li>● Make sure the correct printer driver is selected in the left half of the Chooser. Then make sure that the desired printer name is selected (highlighted) on the right half of the Chooser. There will be an icon next to the printer name after the driver has been set up and configured with the PPD.</li> <li>● If the printer resides on a network with multiple zones, make sure the correct zone is selected in the AppleTalk Zones box in the Chooser.</li> <li>● Make sure the correct printer has been chosen in the Chooser by printing a configuration page (page <a href="#">314</a>). Make sure the name of the printer displayed on the configuration page matches the printer in the Chooser.</li> <li>● Make sure AppleTalk is active. (Select this in the Chooser or in the AppleTalk control panel, whichever is applicable for your OS version.)</li> <li>● Make sure the computer and printer are on the same network. From Control Panels in the Apple menu, select the Network (or the AppleTalk) control panel and then choose the correct network (for example, LocalTalk or EtherTalk).</li> </ul>



**Macintosh Problem Solving (continued)**

<b>Situation</b>	<b>Solution</b>
Auto Setup did not automatically set up the printer.	<ul style="list-style-type: none"><li>● Set up the printer manually by selecting Configure.</li><li>● Reinstall the printer software (page <a href="#">74</a>).</li><li>● Select an alternate PPD (page <a href="#">308</a>).</li><li>● The PPD might have been renamed. If so, select the renamed PPD (page <a href="#">308</a>).</li><li>● A network queue might be present.</li></ul>
The printer driver icon does not appear in the Chooser.	Make sure the Apple LaserWriter 8 Chooser extension resides in the Extensions folder. If it is not present anywhere on your system, you can obtain the driver from your Mac OS system software CD, from Apple Computer, Inc., or call <a href="#">HP Customer Care</a> .
The print job is not sent to the desired printer.	Another printer with the same or similar name might have received the print job. Make sure that the printer name matches the name selected in the Chooser (page <a href="#">308</a> ).



*Macintosh Problem Solving (continued)*



---

Situation	Solution
The print job has incorrect fonts.	<ul style="list-style-type: none"><li>● If you are printing an .EPS file, try downloading the fonts contained in the .EPS file to the printer before printing. Use the HP LaserJet Utility (page <a href="#">80</a>).</li><li>● If the document is not printing with New York, Geneva, or Monaco fonts, go into the Page Setup dialog box, and select Options to deselect substituted fonts.</li></ul>

---



## Selecting an alternate PPD

- 1 Open the **Chooser** from the **Apple** menu.
- 2 Click the **LaserWriter 8** icon.
- 3 If you are on a network with multiple zones, select the zone in the **AppleTalk Zones** box where the printer is located.
- 4 Click the printer name you want to use in the **Select a PostScript Printer** box. (Double-clicking will immediately generate the next few steps.)
- 5 Click **Setup...** (This button might read **Create** for first-time setup.)
- 6 Click **Select PPD....**
- 7 Find the desired PPD in the list and click **Select**. If the desired PPD is not listed, choose one of the following options:
  - ◆ Select a PPD for a printer with similar features.
  - ◆ Select a PPD from another folder.
  - ◆ Select the generic PPD by clicking **Use Generic**. The generic PPD allows you to print, but limits your access to printer features.

**Continued on next page.**



- 8 In the **Setup** dialog box, click **Select**, and then click **OK** to return to the **Chooser**.



**Note**

If you manually select a PPD, an icon might not appear next to the selected printer in the **Select a PostScript Printer** box. In the **Chooser**, click **Setup**, click **Printer Info**, and then click **Update Info** to bring up the icon.



- 9 Close the **Chooser**.



### ***Renaming the Printer***

If you are going to rename the printer, do this before selecting the printer in the **Chooser**. If you rename the printer after selecting it in the **Chooser**, you will have to go back into the **Chooser** and reselect it.

Use the **Set Printer Name** feature in the **HP LaserJet Utility** to rename the printer.



## *Communicating with an Optional HP JetDirect EIO Print Server*

If the printer contains an optional HP JetDirect internal print server, and you cannot communicate with the printer over the network, verify operation of the print server. Check the JetDirect Configuration Page for the message I/O CARD READY. (Follow the steps on page [314](#) to print a configuration page.) For troubleshooting information, see the HP JetDirect administrator's guide.

### *HP JetDirect 610N 10/100Base-TX Print Server*

If the printer contains an optional HP JetDirect 10/100Base-TX print server, check to see that the print server was able to link to the network.

- Check the link-speed LEDs (10 or 100) on the print server. If both are off, the card failed to link to the network.

**Continued on next page.**



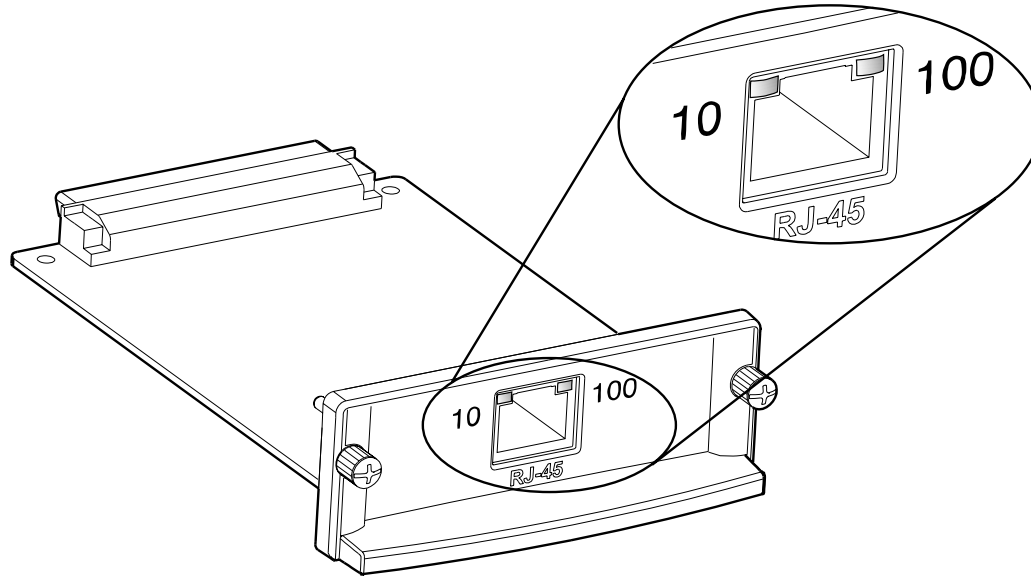

- Check the JetDirect Configuration Page for a `LOSS OF CARRIER` error message. This message also indicates that the card did not link to the network.

**Note**

The HP JetDirect 10/100Base-TX print server may require up to 10 seconds to establish a link to the network.

If you have a different HP JetDirect print server, see the guide that came with it.



**Continued on next page.**



If the print server failed to link, verify that all cables are correctly connected. If the print server still fails to link, follow the steps below to reconfigure the print server.

- 1** Use the EIO menu to manually set the link speed (10 or 100 Mbps) and communication mode (full or half-duplex) so that they match the network. (See the EIO menu on page [460](#).) For example, if the port on the network switch is set for 100TX full-duplex operation, you must set the print server for 100TX full-duplex operation.
- 2** Turn the printer off and back on.
- 3** Check the print server operation. If the print server fails to link, contact a local authorized HP dealer or service representative.





## Checking the Printer's Configuration

From the printer's control panel, you can print pages that give details about the printer and its current configuration. The following information pages are described here:

- [Configuration Page](#)
- [Menu Map](#)
- [PCL or PS Font List](#)
- [Paper Path Test](#)

For a complete list of the printer's information pages, see the Information Menu in the printer's control panel (page [424](#)).



## Configuration Page

Use the configuration page to view current printer settings, to help troubleshoot printer problems, or to verify installation of optional accessories, such as memory (DIMMs), input and output paper handling devices, and printer languages.



---

**Note** If an HP JetDirect EIO card is installed, a JetDirect configuration page will print out as well.

---

To print a configuration page:

- 1 Press **MENU** repeatedly until `INFORMATION MENU` appears.
- 2 Press **ITEM** repeatedly until `PRINT CONFIGURATION` appears.
- 3 Press **SELECT** to print the configuration page.

Numbers in the sample printout match the numbers in the printer messages (page [227](#)). The content of the configuration page varies, depending on the options currently installed in the printer.

**Continued on next page.**





- 1 Printer Information** lists the serial number, HP JetSend IP addresses, page counts, and other information for the printer. If the variable fuser mode has been set to HIGH1, HIGH2, or HIGH3, the number of pages printed at the high fuser temperature is listed in parentheses after the page count.
- 2 Event Log** lists the number of entries in the log, the maximum number of entries viewable, and the last three entries. The second page of the event log is the manufacturing page. This page contains information that may assist HP Customer Care representatives in solving possible printer problems.

Continued on next page.



- 3 Installed Personalities and Options** lists all printer languages that are installed (such as PCL and PS) and lists options that are installed in each DIMM slot and EIO slot.
- 4 Memory** lists the printer memory, Driver Work Space (DWS), and I/O buffering and resource saving information.
- 5 Security** lists the status of the printer's control panel lock, control panel password, and disk drive.
- 6 Paper Trays and Options** lists the size settings for all trays and lists optional paper handling accessories that are installed.
- 7 Toner Level** provides a graphic representation of how much toner is left in the cartridge.



## Menu Map

To see the current settings for the menus and items available in the control panel, print a control panel menu map:

- 1 Press **MENU** repeatedly until `INFORMATION MENU` appears.
- 2 Press **ITEM** repeatedly until `PRINT MENU MAP` appears.
- 3 Press **SELECT** to print the menu map.

You might want to store the menu map near the printer for reference. The content of the menu map varies, depending on the options currently installed in the printer. (Many of these values can be overridden from the printer driver or software application.)

For a complete list of control panel items and possible values, see page [420](#). To change a control panel setting, see page [58](#).



## *PCL or PS Font List*

Use the font lists to see which fonts are currently installed in the printer. (The font lists also show which fonts are resident on an optional hard disk or flash DIMM.)

### *To print a PCL or PS font list:*

- 1 Press **MENU** repeatedly until INFORMATION MENU appears.
- 2 Press **ITEM** repeatedly until PRINT PCL FONT LIST or PRINT PS FONT LIST appears.
- 3 Press **SELECT** to print the font list.

The PS font list shows the PS fonts installed and gives a sample of those fonts. The following describes the information that can be found on the PCL font list:

- **Font** gives the font names and samples.
- **Pitch/Point** indicates the pitch or point size of the font.
- **Escape Sequence** (a PCL programming command) is used to select the designated font. (See the legend at the bottom of the font list page.)

**Continued on next page.**



**Note**

For step-by-step instructions on using printer commands to select a font with DOS applications, see page [486](#).



- **Font #** is the number used to select fonts from the printer's control panel (not the software application). Do not confuse the font # with the font ID, described below. The number indicates the DIMM slot where the font is stored.
  - ◆ SOFT: Downloaded fonts that stay resident in the printer until other fonts are downloaded to replace them or until the printer is turned off.
  - ◆ INTERNAL: Fonts that permanently reside in the printer.
- **Font ID** is the number you assign to soft fonts when you download them through software.



## File Directory Page

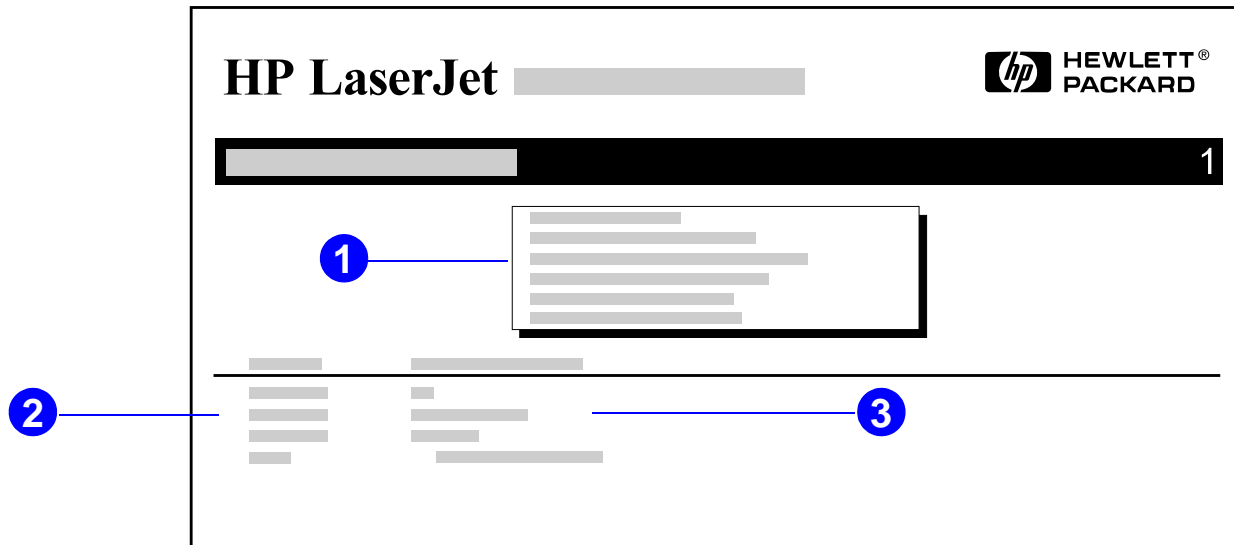

- 1 **Disk Information** indicates the disk model number, serial number, capacity, available free space, and whether you may write to the disk.
- 2 **File Size** column lists the size of each file under the Directory/File Name column. If a directory is listed on the line, then Directory appears in this column and its path is listed in the Directory/File Name column.
- 3 **Directory/File Name** lists the name of the file. Files in a subdirectory are listed right after the directory line. The files are not necessarily listed in alphabetic order.





## Event Log Page

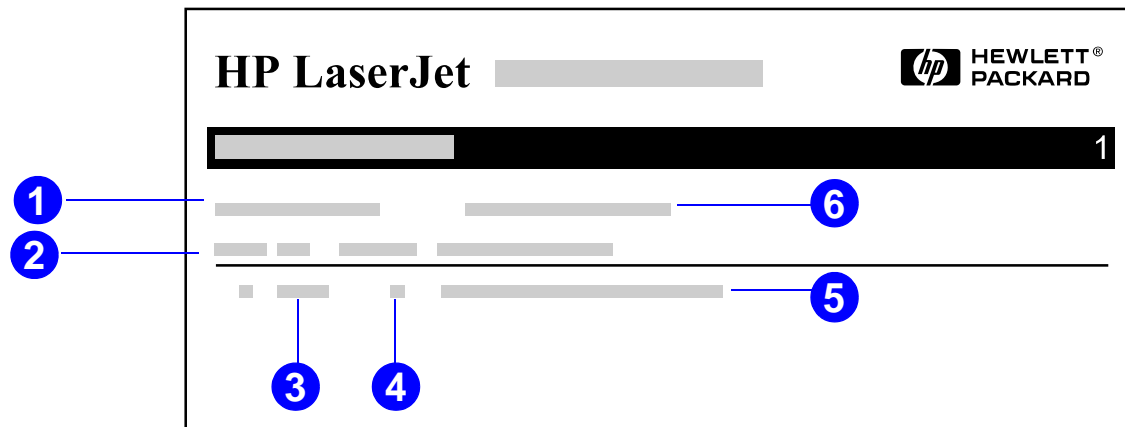

- 1 **Current Page Count** lists the number of printed pages from the printer.
- 2 **Number** indicates the order in which the errors occurred. The last error to occur has the highest number.
- 3 **Error** lists the internal error code for each error.
- 4 **Page Count** indicates the number of printed pages from the printer when the error occurred.

Continued on next page.



- 5 **Description or Personality** indicates whether the error occurred due to a problem within a printer personality or a printer jam.
- 6 **Serial Number** shows the serial number of the printer.

The second page of the event log is the manufacturing page. This page contains information that may assist HP Customer Care representatives in solving possible printer problems.



## Paper Path Test

The paper path test can be used to verify that various paper paths are working properly or to troubleshoot problems with tray configuration.

- 1 Press **MENU** repeatedly until `INFORMATION MENU` appears.
- 2 Press **ITEM** repeatedly until `PRINT PAPER PATH TEST` appears.
- 3 Press **SELECT** to select the paper path test.
- 4 Select the input tray, output bin, duplexer (if available), and number of copies using the - **VALUE** + key and the **SELECT** key. After selecting the last option, the paper path test automatically starts.



# 6 HP Digital Copy



## Overview

The HP Digital Copy provides you with basic copy module features.

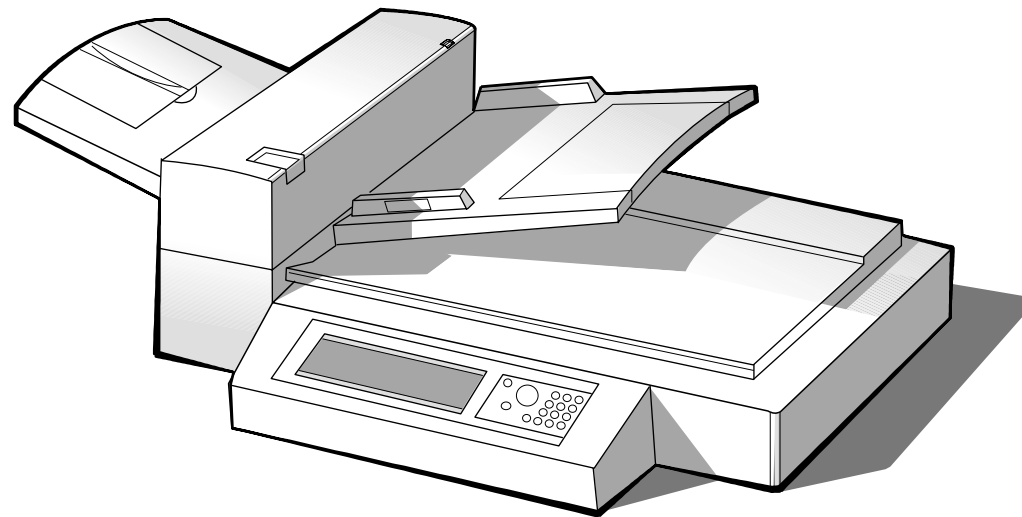

Continued on next page.



# HP Digital Copy Installation



## Installation Checklist

This section will help you install and set up the new HP Digital Copy (Model C4230A). For proper installation, please complete each section in order.

- Unpack the HP Digital Copy (steps 1-2)
- Install the HP Digital Copy (step 3)
- Test HP Digital Copy operation (step 4)



**WARNING!** The HP Digital Copy is heavy. Two people should move it.



# Step 1. Locate HP Digital Copy Parts

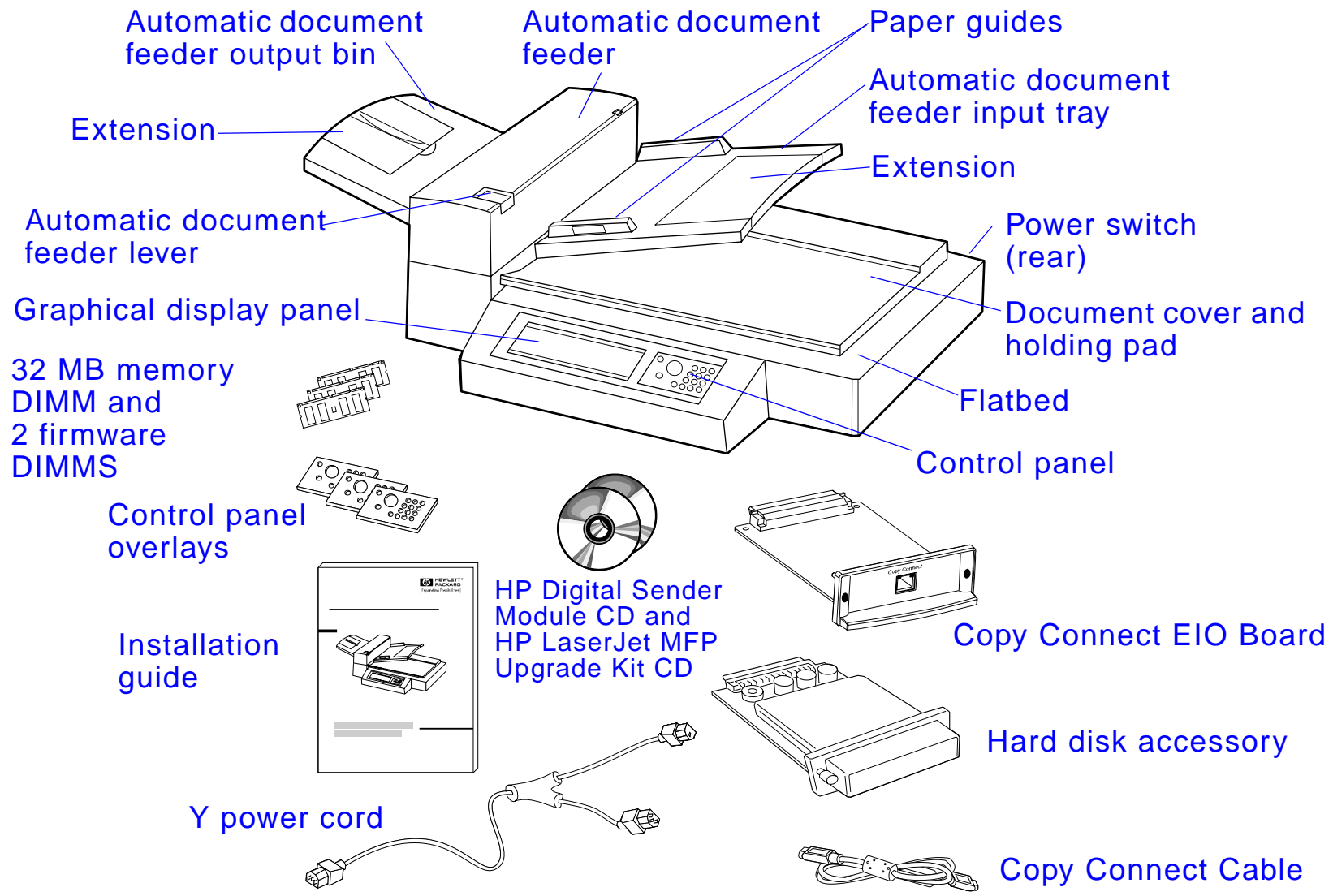

## Step 2. Prepare Printer and HP Digital Copy Location

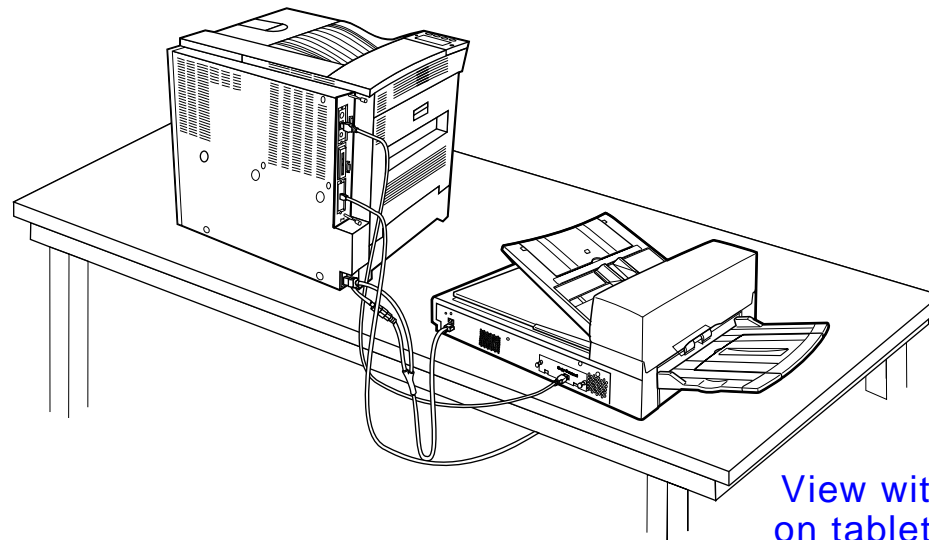

View with HP Digital Copy on tabletop



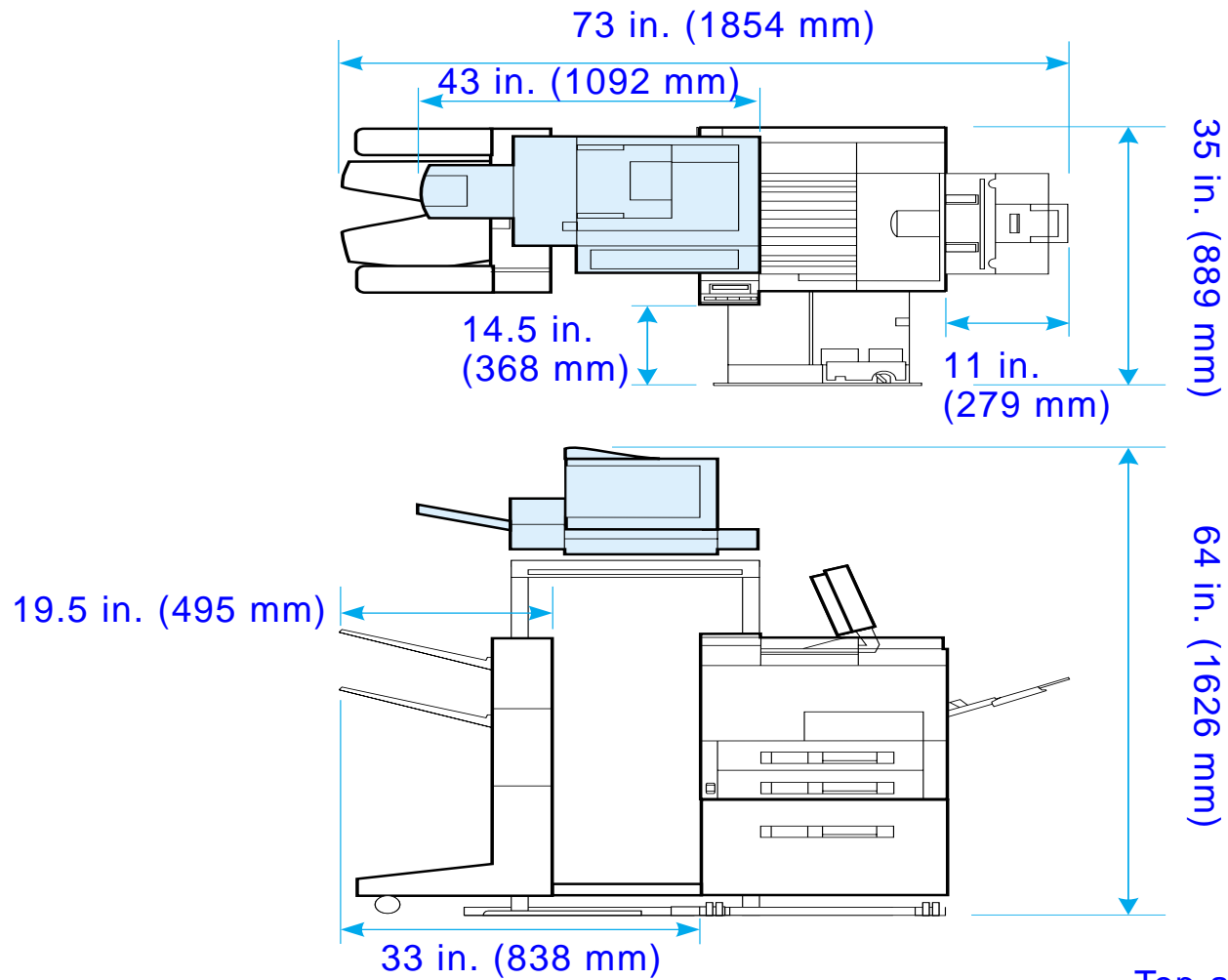

Top and Side Views  
(shown with optional  
accessories)





### ***Location requirements for the HP Digital Copy***

- A sturdy, level surface for placement of the printer and HP Digital Copy.
- Space allowance (see the graphic on page [328](#)) around the printer and HP Digital Copy.
- A well-ventilated room.
- Relative humidity: 20% to 80%.
- Room temperature: 50° to 91° F (10° to 32.5° C).
- A stable environment with no abrupt temperature or humidity changes.
- No exposure to chemicals or direct sunlight.
- One dedicated 15 amp power outlet.



---

**Note**

Be sure to leave enough space to completely extend the optional output accessory away from the printer.



## Installation Specifications



Item		Specification		
<b>Dimensions (mm)</b>		Width: 43 in. (1092 mm)	Depth: 26 in. (660 mm)	Height: 22 in. (559 mm)
<b>Weight</b>		49 lb. (22 kg)		
<b>Input power</b>	Voltage	100 to 127 Vac, 200 to 240 Vac +10%/-10%		
	Phases	Single Phase		
	Frequency	50Hz or 60 Hz +2%/4%		
<b>Power consumption</b>		100 Watts or less		





Item		Specification		
Environmental condition	Device status	Operating	Not Operating	
	Temperature	50° F to 91° F (10° C to 32.5° C)	-4° F to 122° F (-20° C to 50° C)	
	Humidity	20% to 80% RH (no condensation)	15% to 90% RH (no condensation)	



### Step 3. Install the HP Digital Copy

#### ***Install the HP Digital Copy on the Optional HP Digital Copy Stand***

For detailed instructions on setting up the HP Digital Copy Stand, see the installation guide that came with the stand.

- 1 Place the HP Digital Copy Stand near the desired location.

---

#### **Note**

Be sure to leave space for the installation of the accessories. See the graphic on page [328](#) for dimensions.

It is also important to leave space between the stand and the desired location to allow access to the cables during installation.

To use the HP Digital Copy Stand, you must have installed a 2000-sheet Input Tray or a 2 x 500-sheet Input Tray.

---

**Continued on next page.**

1

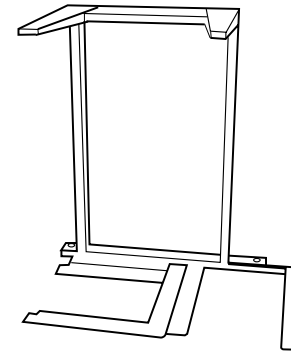

---

**WARNING!**

Use caution when completing the following steps. Once you place the HP Digital Copy on the stand, bumping or moving may cause it to tip. The printer must be moved into position immediately after installation of the HP Digital Copy is complete.

---

- 2 With one other person, lift the HP Digital Copy and align it with the screws on the HP Digital Copy Stand.
- 3 With a flathead screwdriver, screw the HP Digital Copy onto the stand.

---

**CAUTION**

Operating the HP Digital Copy with the shipping lock in place might damage the device. It is important that you perform steps 4 and 5.

---

- 4 Unscrew and remove the shipping lock.

**Continued on next page.**

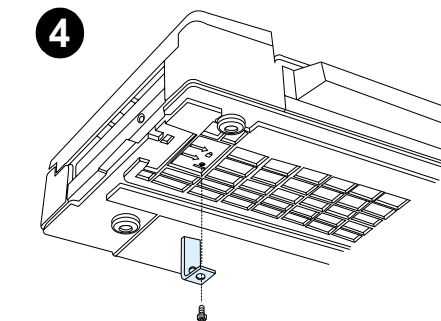
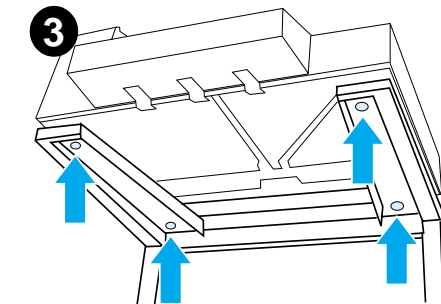
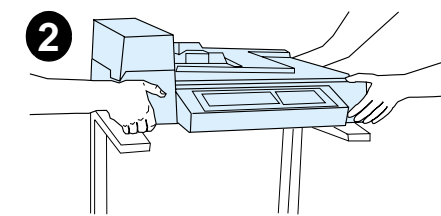
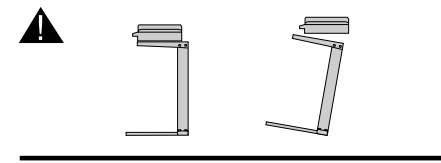

- 5 Rotate the shipping lock and reinsert it into the HP Digital Copy in the unlocked position (this shipping lock is necessary for future moves).
- 6 To install the output bin, hold the bin vertically (as shown) and push down to attach the bin to the metal guides.
- 7 Pull the output bin down. For longer paper, flip the bin extension out as shown.
- 8 Lift the input tray up to lock it into place. For longer paper, flip the tray extension out as shown.

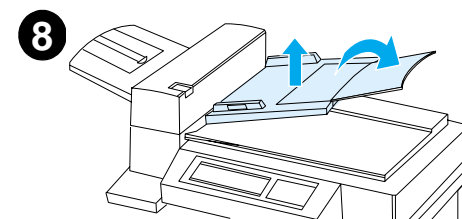
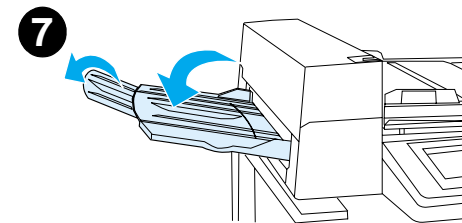
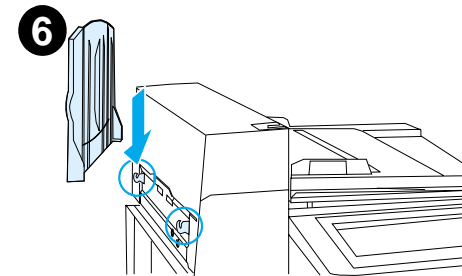
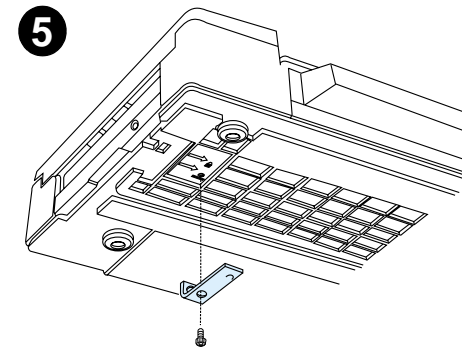

## Install the Printer on the Optional Input Accessory

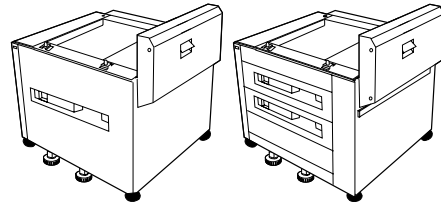

For detailed instructions on installing the printer onto the optional input accessory, see the installation guide that comes with the accessory.

- 1 Roll the Printer onto the Optional HP Digital Copy Stand (gently rock the printer back and forth as you push it onto the stand).
- 2 When the printer is in place, lock the wheels and rotate the levelers up or down to stabilize the printer.

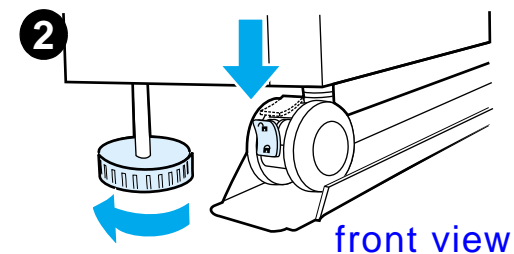
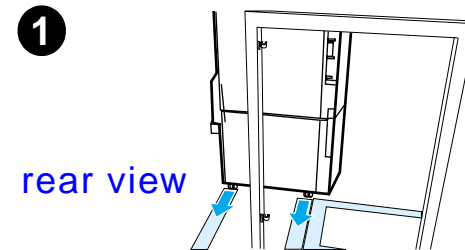

## Install the Optional Output Accessory

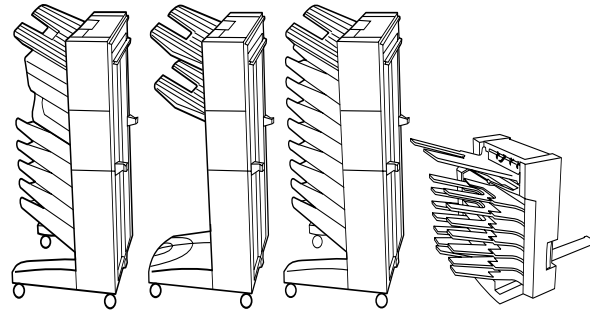

### Note

For detailed information on installing the optional output accessory, see the installation guide that came with the accessory.

- 1 Roll the optional output accessory onto the HP Digital Copy Stand.

### Note

Be sure to properly align the mounting bracket as you roll the optional output accessory onto the HP Digital Copy Stand.

- 2 After the front two rollers are on the base of the HP Digital Copy Stand, attach the mounting bracket.
- 3 Roll the optional output accessory toward the printer until it clicks into place.

**Continued on next page.**





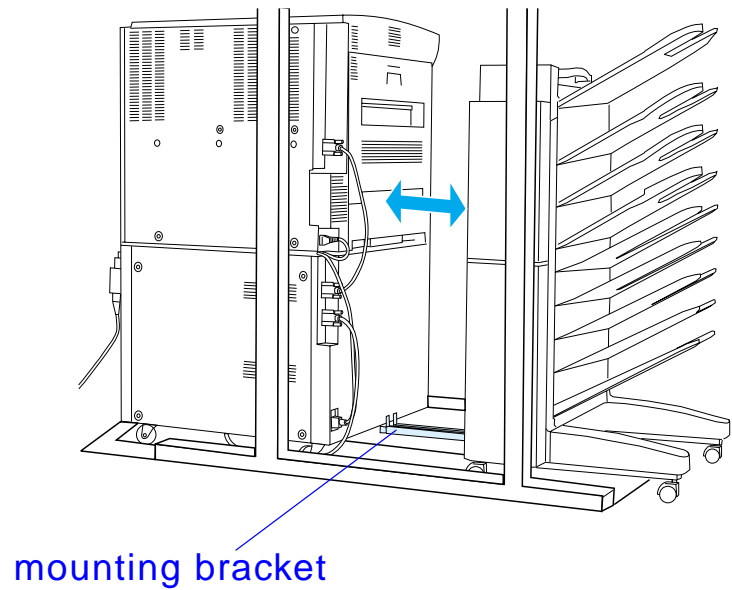

**Note**

When locating the stand, be sure to leave enough space to completely extend the optional output accessory away from the printer. (See page [328](#) for dimensions.)



## Install the Copy Connect EIO Board

**CAUTION** Make sure that the printer is turned off.

Insert the Copy Connect EIO Board that came with the HP Digital Copy into an open EIO slot on the printer. (Use the screws that are in the existing EIO cover to install the Copy Connect EIO Board.)

**Note** If a cover is on the open slot, use a screwdriver to remove the two screws. Remove the cover and install the Copy Connect EIO Board.

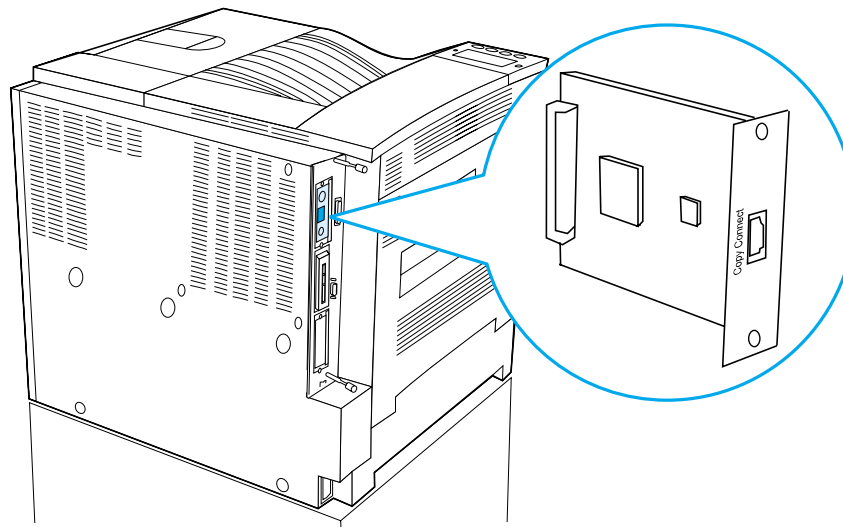

## Install the Copy Connect Cable

- 1 Plug the Copy Connect cable into the HP Digital Copy (A).



**Note** The icon on the cable should be facing up.

- 2 Plug the other end of the Copy Connect cable into the Copy Connect EIO Board (B). (The HP logo facing as shown.)
- 3 If you have a copy stand, wrap the excess cable as shown in the graphic on the next page (C).

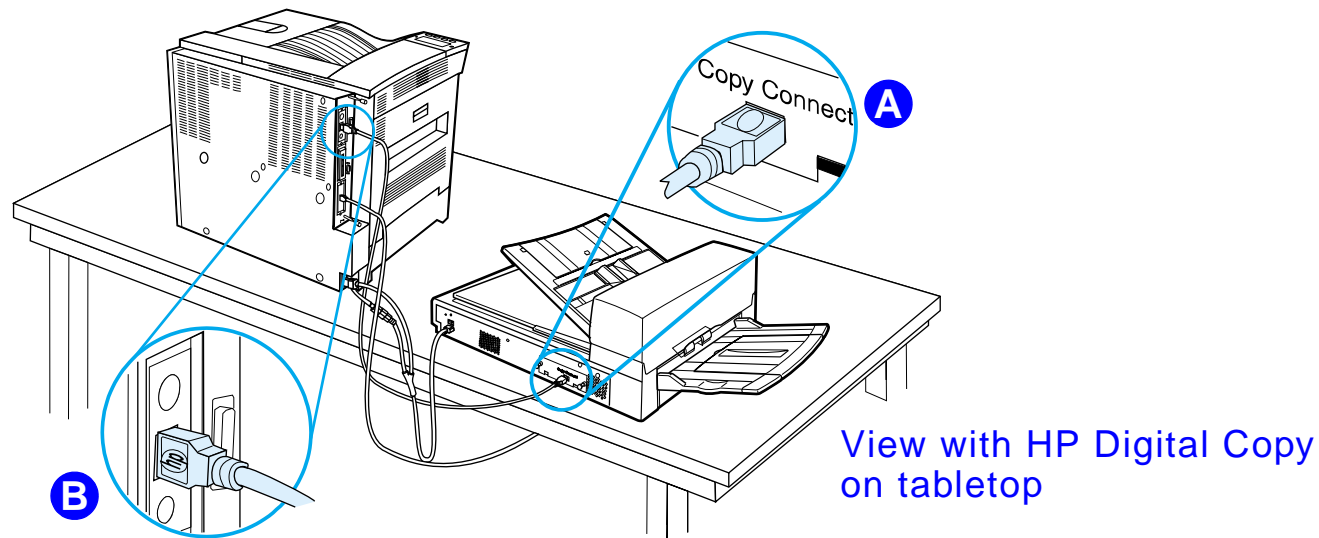

Continued on next page.



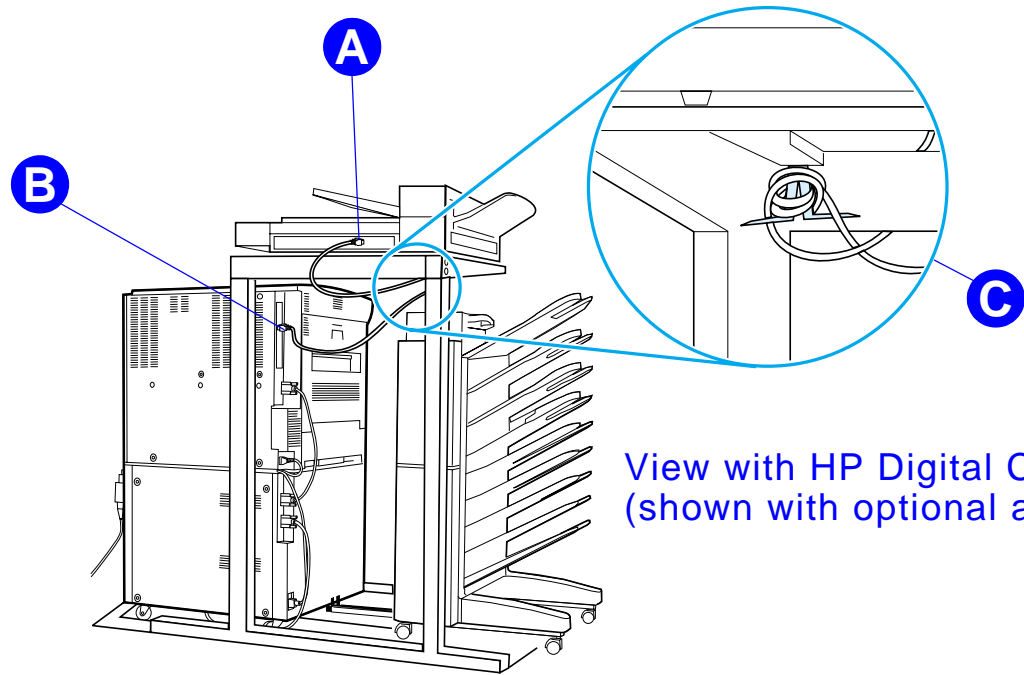

View with HP Digital Copy Stand  
(shown with optional accessories)



## Install the Y Power Cord

### CAUTION

Turn off the printer and make sure the HP Digital Copy power switch is in the off position before you install the Y power cord.

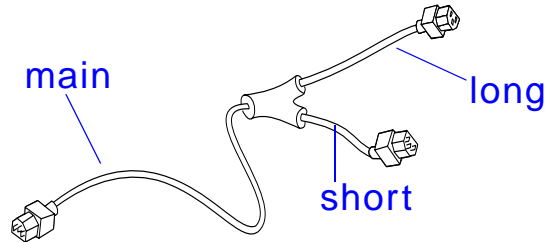

- 1 Plug the main end of the Y power cord into the HP Digital Copy.
- 2 Unplug the power cord from the printer. Plug the power cord into the short end of the Y power cord.
- 3 Plug the long end of the Y power cord into the printer.

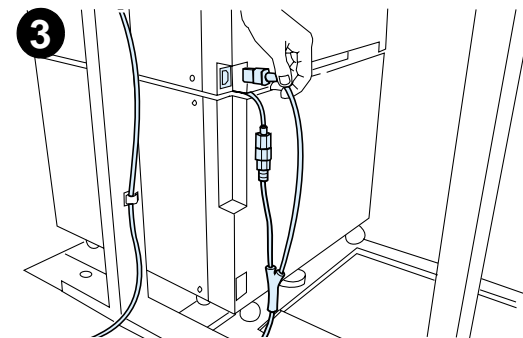
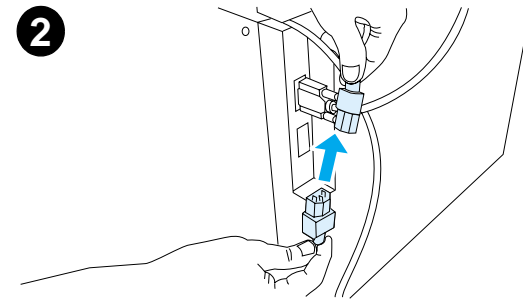
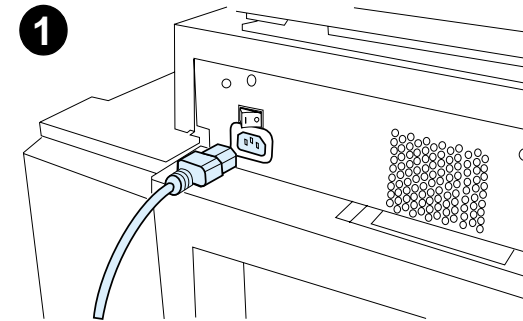

### ***Install the Control Panel Overlay***

- 1 Choose the control panel overlay printed with your language.
- 2 Press the overlay in place on the HP Digital Copy control panel until it clicks.
- 3 To remove the control panel overlay, insert a screwdriver into the slot on the left side of the overlay.

---

#### **Note**

The language that appears on the HP Digital Copy display is customized through the language selected on the printer. If the printer language is set to a language other than those offered by the HP Digital Copy, then the HP Digital Copy will default to English.

---

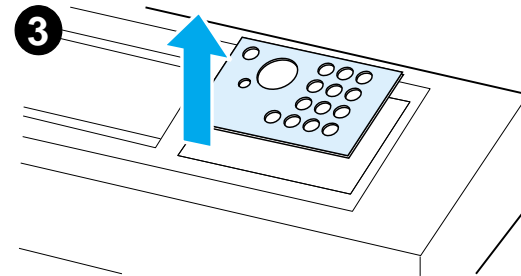
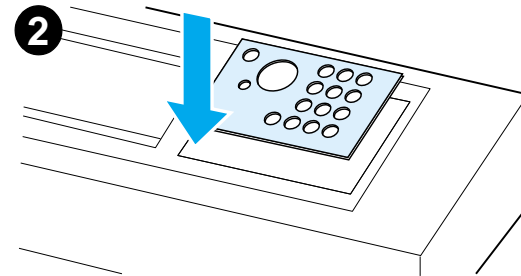
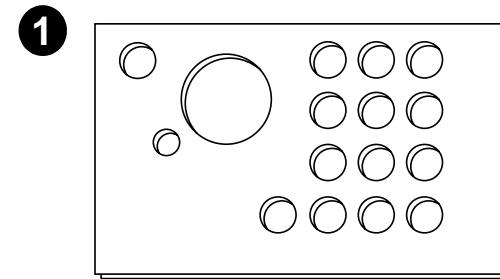

## Step 4. Test HP Digital Copy Operation

- 1 Turn on the printer. When **READY** displays, turn on the HP Digital Copy.
- 2 The HP Digital Copy displays the HP logo followed by icons that illustrate the different initialization phases.

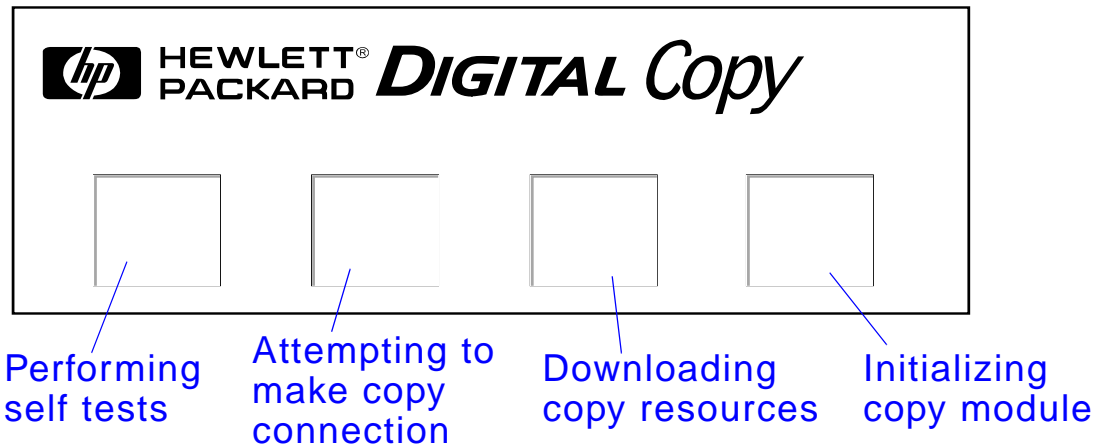

- 3 The HP Digital Copy displays **READY TO COPY** when it has finished initialization.

**Note** The green LED lights up on the **START** button to show that the HP Digital Copy is ready to copy (see page [359](#)). If there is a problem getting to the **READY TO COPY** state with the HP Digital Copy, see page [345](#) or call your service provider.

Continued on next page.



- 4 Load the original document face down into the automatic document feeder or place it on the flatbed of the HP Digital Copy (see pages [364](#) and [366](#)), and select the desired number of copies. A green LED lights up on the automatic document feeder cover to show that you have properly inserted the documents into the feeder.
- 5 Press the **START** button on the display panel to start copying.



---

**Note**

The original document will come out in the HP Digital Copy output bin when using the automatic document feeder or will remain on the flatbed of the HP Digital Copy. Output copies will be printed on the printer and will be located in the printer output bin.

---





## Troubleshoot the HP Digital Copy



**Note** For detailed information on troubleshooting, see [HP Digital Copy Problem Solving](#) on page [377](#).



---

<b>Problem</b>	<b>Recommended Action</b>
<b>No power</b>	Check that all power cords are connected correctly.
<b>Failed initialization or No copy</b>	Check that the printer is turned on.  Check that the Copy Connect EIO Board is installed correctly.  Check that the Copy Connect EIO cable is connected correctly.

---



## *HP Digital Copy Operating Instructions*

This section shows you how to use the HP Digital Copy and many of its advanced features.



### *HP Digital Copy Features and Benefits*

- Auto/Photo/Text modes
- Job Interrupt (at copy boundaries)
- N-up layout (printing multiple pages per sheet)
- Operator attendance animations (for example, paper jam recovery)
- Auto-configure to printer settings
- Copy books
- Custom stapling
- Power Save
- One pass duplex scanning



# HP Digital Copy Control Panel

## Control Panel Layout and Display Settings

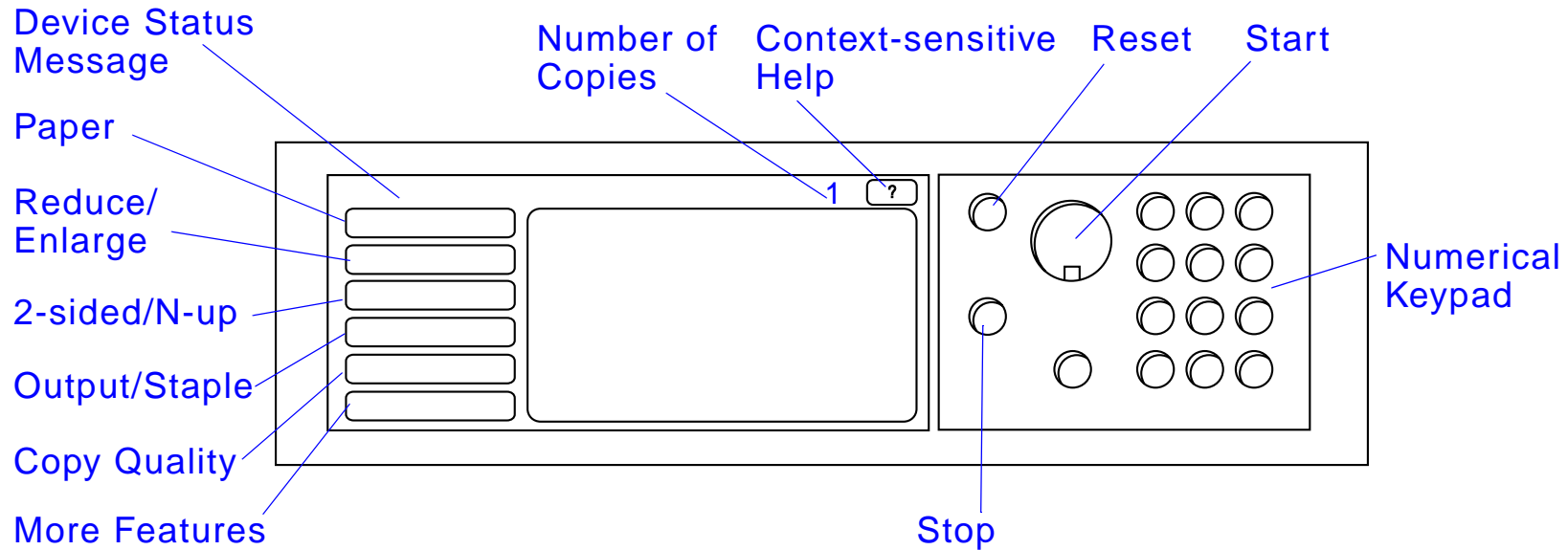

**Status Bar**

The Status Bar displays the current:

- [device status message](#)
- [number of copies selected](#)
- [context-sensitive help button](#)



---

<b>device status message</b>	The <code>READY TO COPY</code> , <code>COPYING</code> , or <code>ACCEPTING COPY JOBS</code> message is displayed. <code>ACCEPTING COPY JOBS</code> indicates that the printer is busy. You can configure the next copy job when the printer is busy.
------------------------------	--



---

<b>number of copies selected</b>	The current number of copies selected for the copy job is displayed. This setting defaults to 1.
----------------------------------	--

---

<b>context-sensitive help button</b>	This button remains present on the control panel display unless an error is displayed. When selected, a help topic related to the current control panel message appears.
--------------------------------------	--

---



## Menu Tabs

---



Menu Tabs allow access to any of the HP Digital Copy settings. Each tab shows related job settings. Select OK or Exit to make changes as you move from tab to tab. Press OK to exit the menu tabs and start a copy job. Press Exit to return to the default display tab. You can also select Start to begin a copy job before exiting the menu tabs.



### Menu tabs

- [paper tab](#)
- [reduce/enlarge tab](#)
- [2-sided/N-up tab](#)
- [output/staple tab](#)
- [copy quality tab](#)
- [book copy tab](#)
- [job binding tab](#)
- [configuration tab](#)
- [about tab](#)



**Menu Tabs (continued)**

---

**paper tab**

Allows you to choose output paper for the copy job based on size, tray, or type.

- **Size** - Shows the current size selected. When a selection is made, the Tray list will update automatically.
- **Tray** - Shows the current tray selected. If the selected paper size is currently installed in multiple trays, the Tray selection text will highlight **AUTOMATIC**. This indicates that the printer will make the tray selection based on its auto-selection criteria. If the selected paper size is located in only one tray, the location will be shown by the list text. When a selection is made, the Size and Type will update automatically.

**Note**

If you choose a paper type that is not already loaded in the printer, the printer will prompt you to load Tray 1 with the correct paper before the job is printed.



*Menu Tabs (continued)*

---

**reduce/enlarge tab**

Allows you to enlarge or shrink the size of the document. Allows you to choose the paper size for your original document and specify a different size for the copy. For example, copying from A4 to letter. You may also specify the output paper size and then choose a scaling percent to reduce or enlarge a region of the source document. You may choose to copy a full-bleed page onto the printable region of the output paper.

You are presented with the following controls for selecting the desired paper scaling percent:

- **Reduce/Enlarge** - Shows input-to-output paper sizes. When a size is selected, the proper scaling percent for the currently selected input and output paper sizes is displayed.
- **Percent** - Shows the current page scaling percent.



*Menu Tabs (continued)*

---

**reduce/enlarge tab  
(continued)**

- **Custom Media Reduction** - This setting allows you to switch between the standard/enlargement settings and the custom mode. This allows you to choose your original and copy document sizes independently.

When the Custom Media Reduction box is checked, you can select a paper size under the Original list for your original document and then select the paper size in the Copy list for the size you want to copy. The percent text box automatically calculates page scaling percent.

When the Custom Media Reduction box is unchecked, you may select from a list of standard reduction or enlargement settings, such as Letter (LTR) to Legal (LGL). Also, you may select the Manual setting in order to adjust the scaling percent by hand. When Manual is selected you may increase or decrease the scaling percent by one percent increments. You may reduce a document by up to 25 percent or enlarge a document by up to 200 percent. When you have chosen Manual, you may also choose the size of your original document. The copier will reduce that document by the percent you have selected.





*Menu Tabs (continued)*

---

**reduce/enlarge tab  
(continued)**

- **Shrink Page to Printable Region** - This setting allows you to adjust the page scaling percent. This allows you to copy a full-bleed page onto the printable region of the currently selected output paper size. There are limits to how far out to the edge of the page the printer can print. If you are copying a page that has printing all the way out to the edges (full bleed), then checking this box will cause the image to be reduced slightly so that the entire edge-to-edge image may print within the printable region of the output paper.



*Menu Tabs (continued)*

---

**2-sided/N-up tab**

This tab has four controls for setting up the options and a preview image that graphically illustrates the current settings.

- **2-sided Copying** - Shows the currently selected 2-sided mode. Choose the two-sided mode you need. The preview image will update to display your choice.
- **Flip Pages Up** - This setting is active if the you choose to copy onto both sides of the output paper. By default, the pages of the two-sided binding are flipped to the left, like a book, when viewed from the backside of the job. When this setting is checked, the pages are bound, appearing flipped up when viewed from the backside of the job. The preview image will update to display your choice.
- **N-up Copying** - Shows the currently selected number of input pages to be printed on each output page. Choose the number of input pages needed to print on each output page. The preview image will update to display your choice.
- **Print Page Borders** - This setting is active when you select two or more pages for each sheet. When checked, page borders will print around each page image on the output page. The preview image will update to display your choice.



*Menu Tabs (continued)*

---

**output/staple tab**

You can configure the output and stapling options using the two main controls on this tab.

- **Output Bin** - Shows the currently selected output bin. Choose which bin the copy job will be delivered to. If the output bin is set to the stapling bin and a stapling option is selected, then changing the output bin to another location will turn off the stapling option.
- **Stapling** - Allows you to choose stapling options. The number of options displayed will depend on the stapling device installed. If you select an option to have the output stapled, then the Output Bin setting will change to display that stapling can only take place in the staple bin.

**copy quality tab**

- **Copy Mode** - You may change the copy quality settings from this tab. There are three settings to choose from in Copy Mode:
  - Auto** - This is the default mode.
  - Photo** - This mode is optimized for photo clarity.
  - Text** - This mode is optimized for text sharpness.
- **Brightness** - You may change the brightness setting from this tab. Press the left or right arrow to increase or decrease the brightness level as indicated by the slider. There are five settings for brightness.



*Menu Tabs (continued)*

---



**book copy tab**

Allows you to make a copy of an open book with a single page of output for each page of the book. Align the spine of the book with the book markings on the flatbed paper guides.

- Follow the prompts provided on the control panel when using this mode.
- You can copy multiple pages from a book and bind them together as one job. See the job binding tab description for more information.



**job binding tab**

Takes multiple copies from the flatbed and binds them together as one job. All other copy settings, such as stapling and number of copies, will be applied to the bound job.

- Follow the prompts provided on the control panel when using this mode.

**configuration tab**

Provides configuration settings for the HP Digital Copy. For example:

- Allows you to turn on or off the audible key feedback.
- Allows you to adjust the control panel display contrast.



**Menu Tabs (continued)**

---

**about tab**

Used to find available help topics.

Displays:

- system version information
  - current page counts for the flatbed and automatic document feeder
  - number of pages until the next required service
- 



**Context-sensitive Help**

---

Press the  to enter the HP Digital Copy help system. Follow the prompts provided in the help system to find quick descriptions of HP Digital Copy features and functions.

---



### Default Configurations

---



If the HP Digital Copy is idle and unattended for one minute, the HP Digital Copy settings will return to the default configuration. Press the Reset key on the control panel to return all of the HP Digital Copy settings to the default configuration.



The setting changes that you make will remain for one minute before they reset to a default setting. For example, if you walk up to the HP Digital Copy and press the 5 key, the number of copies selected will be set to five. If you do not make any other setting changes and do not initiate a job by pressing the Start key within one minute, then the number of copies selected will automatically return to one.



After a copy job is completed, the current settings will not change until after another minute expires. This makes it possible to set up the HP Digital Copy settings in a particular manner only once for a number of jobs.

**Note:**

The post-job timeout period will be shorter than the idle timeout period.

---



## Button/LED Functions

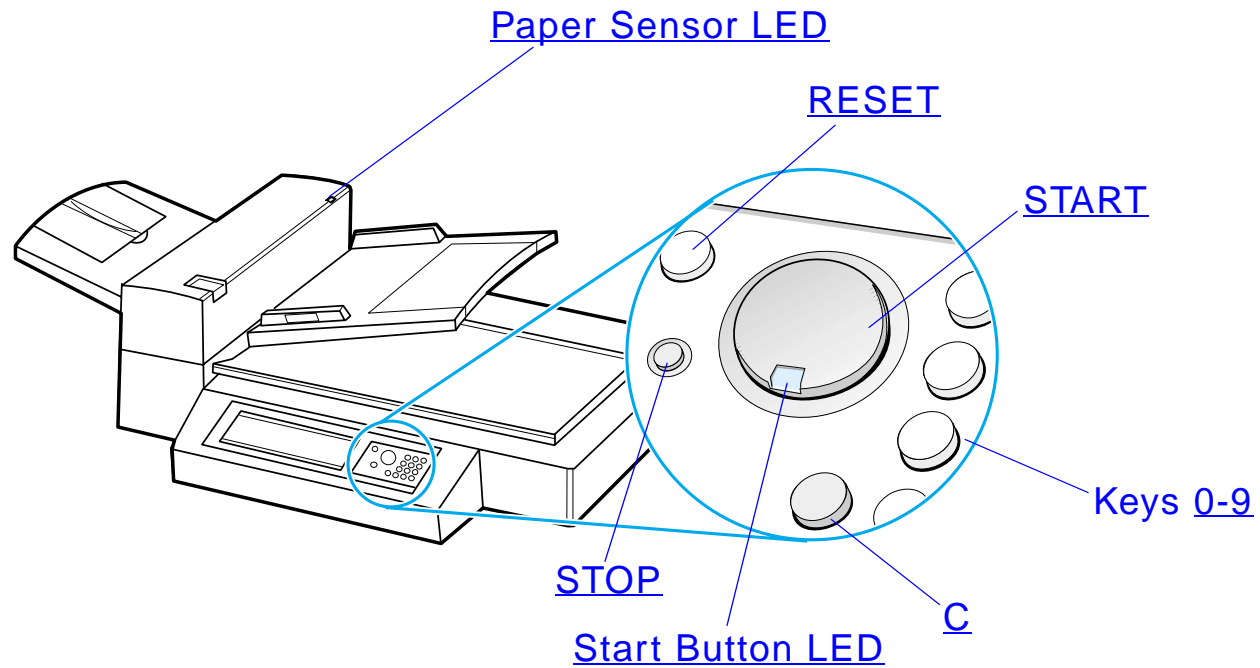

Continued on next page.





Name of the button and LED		Function
<b>Button</b>	0-9	Use to enter the number of copies you desire. May also be used periodically to enter a numerical value.
	RESET	Resets all of the copier settings to the default values.
	START	Begins a copy job or continues a copy job that has been interrupted because of an error.
	STOP	Stops a copy job.
	C	Clears the number of copies setting. (Does not clear the other copy module settings.)
<b>LED</b>	Paper Sensor LED	Illuminates when paper is aligned correctly in the automatic document feeder.
	Start Button LED	See <a href="#">Start Button LED</a> on page <a href="#">361</a> for a detailed description of this LED.





**Start Button LED**

LED\State	On	Flashing Slow	Flashing Fast
<b>Green</b>	The copy module is ready to make copies.	The copy module is in Power Save mode.	The copy module is making copies.
<b>Amber</b>	The copy module has a critical error. Turn the printer and copy module off, and then turn the printer and copy module on.	The copy module has an error and requires attention.	The copy module has an error that requires attention from your service provider.

**Note**

When the copy module is in Power Save mode, the back light of the display panel will be turned off and the Start LED (green) will flash at a slow rate to indicate that the system is turned on. To bring the system out of Power Save mode, place paper in the automatic document feeder, press any key on the numerical keypad, or touch the touchscreen.



## HP Digital Copy Settings



Feature	Description	Default
<b>Number of copies</b>	1 to 999	1
<b>Paper Source Select</b>	Selection of paper tray Selection by paper size	Auto-select (any tray) Letter/A4 Plain
<b>Collation</b>	Collated Grouped (uncollated) Stapled Select output bin	Collated
<b>Reduce/Enlarge</b>	25% to 200% in 1% increments Support standard presets, such as Legal to Letter.	100%
<b>Copy quality</b>	auto, text, photo	auto



Feature	Description	Default
<b>Duplex</b>	1-1, 1-2, 2-1, 2-2  If the printer does not have a duplexer installed, then 1-2 and 2-2 are not available.	1-1
<b>N-up</b>	1-up, 2-up, 4-up  2-up documents will be rotated.	1-up
<b>Book copy</b>	Copies an open book with a single page of output for each page of the book.	Not selected
<b>Brightness</b>	5 levels (2 lighter, normal, 2 darker)	Normal



## Loading documents into the Automatic Document Feeder

- 1 Pull up on the automatic document feeder input tray (A) and place the bar (B) in operating position.
- 2 Square up and insert paper face down into the input tray. Only load paper up to the line indicator on the paper guide.

---

### Note

The system will exit Power Save when you place the document into the automatic document feeder.

The LED will light up when paper is loaded correctly.

Remove paper clips and staples. Flatten the staple holes.

---

- 3 If the document size exceeds A4 or Letter size, extend the input tray and output bin by flipping out the extensions.

**Continued on next page.**

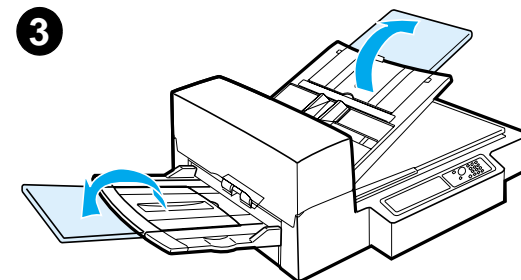
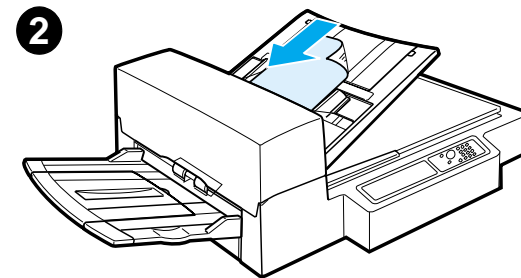
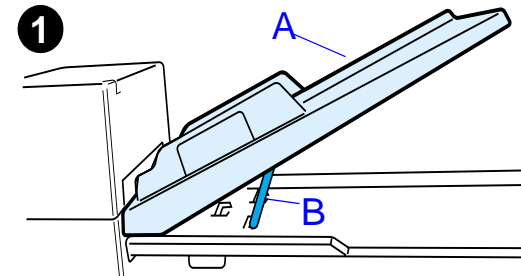

- 4 Set the guides so that there is a little amount of clearance between the side edges and the guides. Adjust the guides to the document size.

---

**Note**

Squeeze the guide lever to free the guides. Load documents so that the thickness is less than 0.32 inches (8 mm).

Set the guides so that they touch the document sides.

---

- 5 After a document is copied, remove the original from the HP Digital Copy and the copy from the printer output bin.

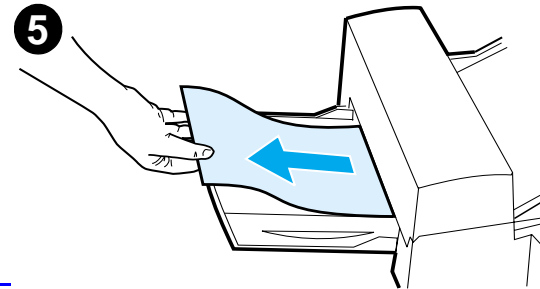
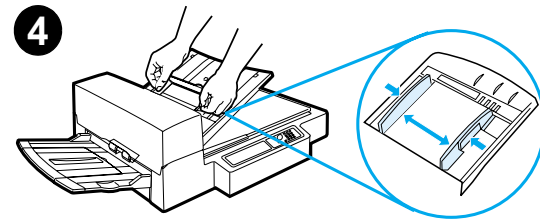

## Loading documents onto the Flatbed

- 1 Open the document cover.
- 2 Place the document face down and align the top left with the reference mark. Slowly close the document cover and press **START**.

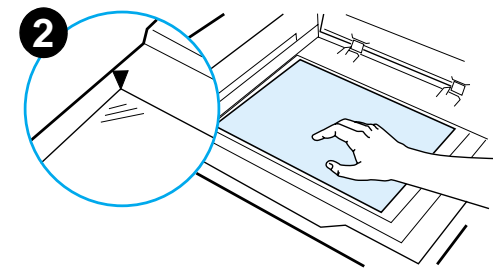
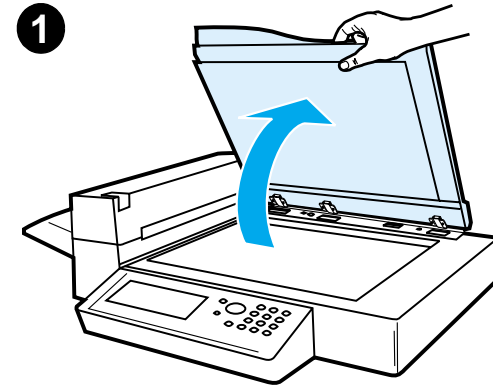

## Loading documents larger than the Document Board

- 1 Open the document cover about 80°. Remove the cover by unscrewing the thumb screw (bottom arrow) and then sliding the cover in the direction of the top arrow.
- 2 Place the document face down on the document bed and press **START**.

When the job is complete, remove the document. Reattach the document cover and close.

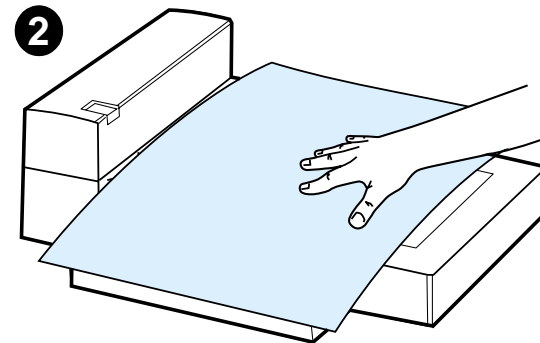
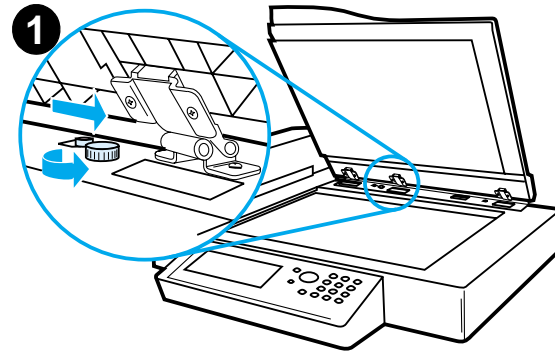

## Reading a page from a thick book

- 1 Open the document cover.
- 2 Place the book face down on the document bed and press **START**.

---

### Note

Do not move the book during job operation.

---

For advanced book copy features, see page [356](#).

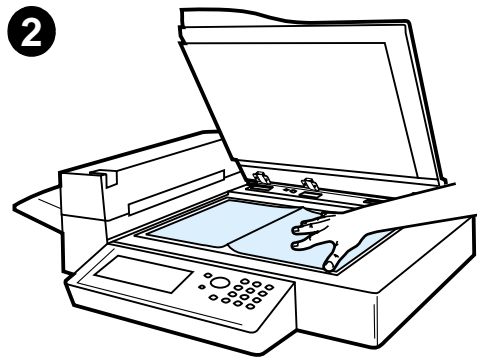
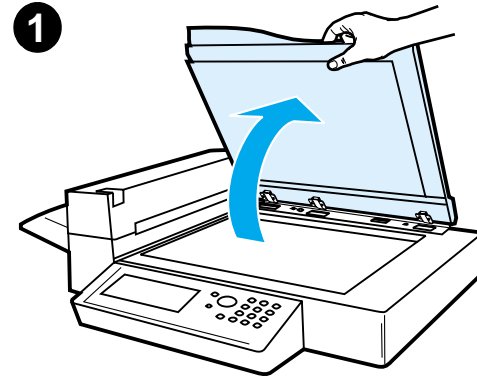



## Foreign Interface Harness<sup>1</sup>

This feature allows the user to monitor, via a job accounting device, the number of copies sent through the HP Digital Copy module.



**Note** The number of printed pages from the printer will not be counted using the Foreign Interface Harness. Only the number of copied pages from the HP Digital Copy module will be counted.



To enable this feature, see the HP LaserJet MFP Upgrade Kit for HP LaserJet 8000, 8100, and 8150 Printers User Guide for more information.



---

1. For use with an HP LaserJet 8150 MFP or any model of HP LaserJet 8150 printer with an HP Digital Copy attached.



## Paper Specifications

### Supported Sizes

- **Ledger** - 11 x 17 in. (279 x 432 mm)
- **Executive** - 7.3 x 10.5 in. (191 x 267 mm)
- **Letter** - 8.5 x 11 in. (216 x 279 mm)
- **Legal** - 8.5 x 14 in. (216 x 356 mm)
- **A3** - 11.7 x 16.5 in. (297 x 419 mm)
- **A4** - 8.3 x 11.7 in. (210 x 297 mm)
- **A5** - 5.8 x 8.2 in. (148 x 210 mm)
- **B4 (JIS)** - 10.1 x 14.3 in. (257 x 364 mm)
- **B5 (JIS)** - 7 x 9.9 in. (176 x 250 mm)



**Note** The automatic document feeder holds up to 50 sheets of paper.



## Document Quality

### ***Do not load the following into the Automatic Document Feeder***

- Carbonless paper
- Carbonless forms
- Paper with clips or staples
- Paper that has been clipped or stapled
- Paper with wet ink
- Labels

### ***Precautions***

The following documents might be hard to feed through the automatic document feeder. If the document slips in the automatic document feeder (Jam Error) or a double feed occurs often, use the HP Digital Copy flatbed.

- Paper of unequal thickness, such as envelopes
- Paper with large wrinkles or curl
- Color copied paper

**Continued on next page.**



- Paper with folds or tears
- Tracing paper
- Coated paper
- Carbon paper
- Paper smaller than 6 x 4 in. (148 x 105 mm) or larger than A3 or Double Letter
- Other than paper
  - ◆ cloth
  - ◆ metal foil
  - ◆ transparency film
- Photographic paper
- Paper with notches on the side
- Paper that is not rectangular
- Thin paper



## HP Digital Copy Maintenance



### Clean the Document Cover, the Document Holder, and the Flatbed Glass



Use a dry cloth or a cloth with a neutral cleanser or isopropyl alcohol to remove dirt from the document cover, document holder, and flatbed glass.



**CAUTION** Do not use organic solvents such as a thinner.

Make sure that no liquid enters the scanner from the edges of the flatbed glass.

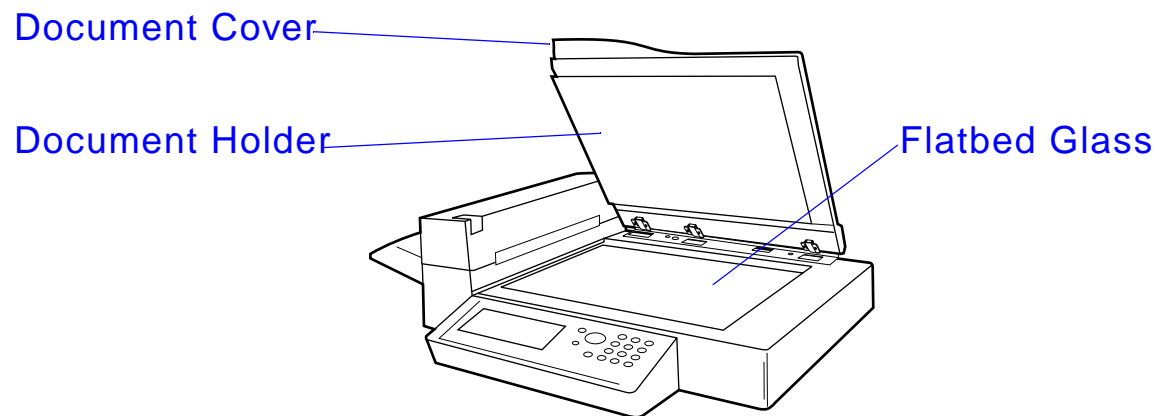

## Cleaning the Automatic Document Feeder

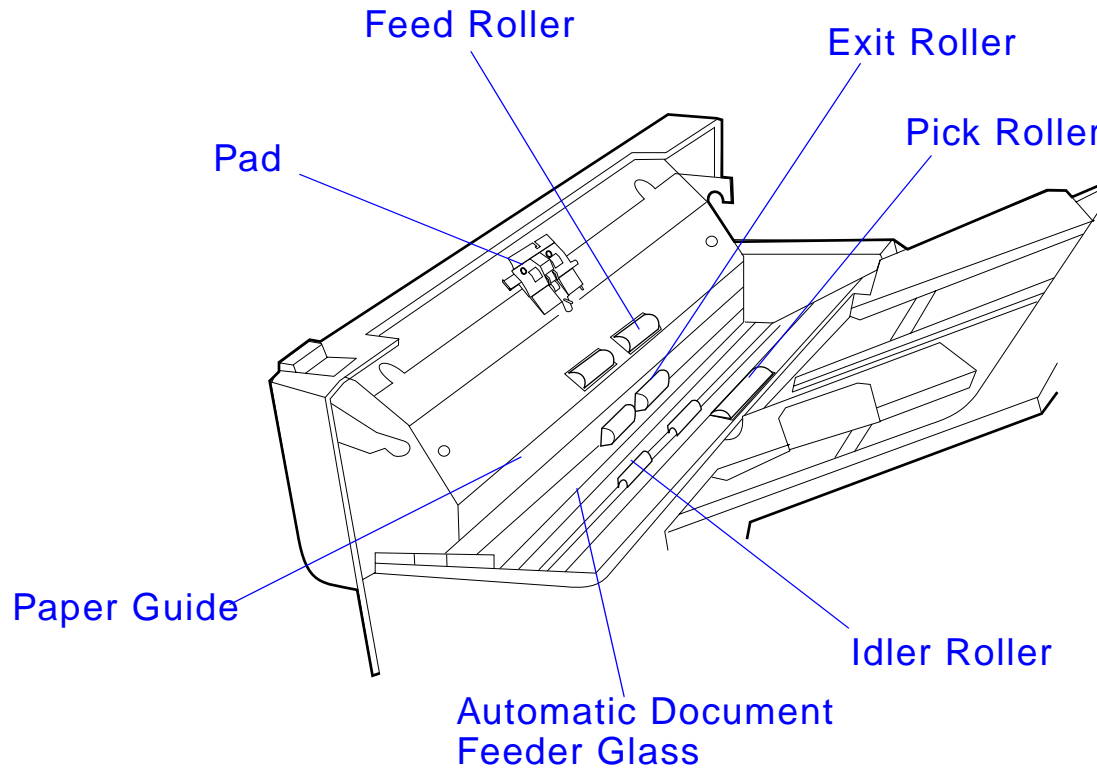

Continued on next page.





---

**Pad** Use a cloth with isopropyl alcohol to wipe the pad in a downward direction. Be careful not to hook the springs when wiping. A dirty pad can cause double feeds.

**Automatic Document Feeder Glass** Wipe the glass lightly with a cloth and isopropyl alcohol to remove any paper dust or toner. Dirty glass can cause vertical streaking when using the automatic document feeder.

**Pick Roller** Use a cloth with isopropyl alcohol to wipe the roller in a horizontal direction. Be careful not to damage the surface of the roller. A dirty pick roller can cause misfeeds, paper slippage, and jams.

**Feed, Exit, and Idler Rollers** Use a cloth with isopropyl alcohol to wipe the rollers in a horizontal direction. Make sure to remove any built-up toner or ink. Be sure the rollers are dry before using the automatic document feeder. Dirty rollers can cause paper jams.

**Paper Guide** Gently wipe the paper guide area. A dirty or worn paper guide can cause vertical streaking.



---

**Note** If the HP Digital Copy is experiencing chronic misfeeds, then contact your service provider to have it cleaned.



## Pad and Roller Maintenance

Cleaning of the pad and rollers is recommended every 6,000 pages.

Every 60,000 pages the pad and pick roller need to be replaced.

Print a configuration page for page count information since the last maintenance. To print a configuration page, turn the printer on and be sure **READY** is displayed. Press **MENU** until **INFORMATION MENU** displays. Press **ITEM** until **PRINT CONFIGURATION** displays. Press **SELECT** to print the configuration pages.

Call your service provider to perform this service.



---

### Note

In certain areas of California, air pollution control regulations restrict the use of liquid Isopropyl Alcohol (IPA) as a cleaning agent. In those areas of California, please disregard the previous recommendations and use a dry, lint-free cloth. The cloth may be moistened with water if desired.

---





## HP Digital Copy Problem Solving

This section shows status messages that display on the HP Digital Copy control panel when there is a problem with the HP Digital Copy. There are two different types of errors made by the HP Digital Copy:

- [Temporary Error](#)
- [Equipment Error](#)

For printer error messages and problem solving information, see the printer user guide.

All error conditions will fill up the entire HP Digital Copy control panel display.

**WARNING!** Make sure the power is off and the main power to the system has been disconnected before servicing.



## Temporary Error

A Temporary Error displays when problems with the paper path occur. The control panel will display the specific error and graphically illustrate the actions needed to correct the error.

Automatic Document Feeder

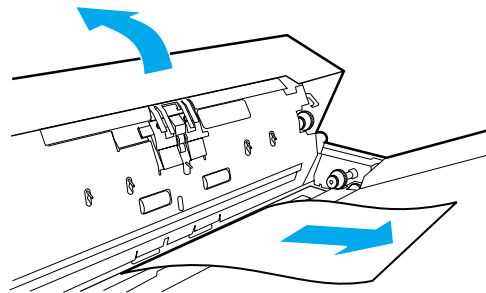

Error Message	Description
ADF PAPER JAM	A page has jammed inside of the automatic document feeder and must be cleared for copying to continue.
ADF COVER IS OPEN	The automatic document feeder cover is open and must be closed for copying to continue.
ADF MISFEED	A misfeed occurred from the automatic document feeder input tray. Restack the pages in the automatic document feeder input tray. Press <b>START</b> to continue the copy job.



## Equipment Error

To correct an equipment error, turn the printer and HP Digital Copy off and then turn the printer and HP Digital Copy on. If the error message persists, then call your service provider.



Error Message	Description
Device Error: Backside RAM Buffer Failure	An error occurred while accessing the backside RAM buffer. This error might require service to correct.
Device Error: Motor Fuse Failure	The motor has a blown fuse. This error might require service to correct.
Device Error: Lamp Fuse Failure	The lamp has a blown fuse. This error might require service to correct.
Device Error: Backside Optical Failure	A problem occurred with the backside optical system. This error might require service to correct.
Device Error: Frontside Optical Error	A problem occurred with the frontside optical system.
Device Error: Mechanical Failure	A mechanical problem occurred. Check to make sure that the shipping lock has been removed and reinserted properly.





# 7 *Service and Support*

## *Overview*

- [Hewlett-Packard limited warranty statement](#)
- [Limited Warranty for Toner Cartridge Life](#)
- [HP Software License Terms](#)

## *Hewlett-Packard limited warranty statement*



HP PRODUCT	DURATION OF WARRANTY
HP LaserJet 8150, 8150 N, 8150 DN, 8150 HN, 8150 MFP	1 year, on-site



1. HP warrants HP hardware, accessories, and supplies against defects in materials and workmanship for the period specified above. If HP receives notice of such defects during the warranty period, HP will, at its option, either repair or replace products which prove to be defective. Replacement products may be either new or like-new.
2. HP warrants that HP software will not fail to execute its programming instructions, for the period specified above, due to defects in material and workmanship when properly installed and used. If HP receives notice of such defects during the warranty period, HP will replace software media which does not execute its programming instructions due to such defects.
3. HP does not warrant that the operation of HP products will be uninterrupted or error free. If HP is unable, within a reasonable time, to repair or replace any product to a condition as warranted, customer will be entitled to a refund of the purchase price upon prompt return of the product.
4. HP products may contain remanufactured parts equivalent to new in performance or may have been subject to incidental use.



5. The warranty period begins on the date of the delivery or on the date of installation if installed by HP. If customer schedules or delays HP installation more than 30 days after delivery, warranty begins on the 31st day from delivery.
6. Warranty does not apply to defects resulting from (a) improper or inadequate maintenance or calibration, (b) software, interfacing, parts or supplies not supplied by HP, (c) unauthorized modification or misuse, (d) operation outside of the published environmental specifications for the product, or (e) improper site preparation or maintenance.
7. TO THE EXTENT ALLOWED BY LOCAL LAW, THE ABOVE WARRANTIES ARE EXCLUSIVE AND NO OTHER WARRANTY, WHETHER WRITTEN OR ORAL, IS EXPRESSED OR IMPLIED AND HP SPECIFICALLY DISCLAIMS THE IMPLIED WARRANTIES OR CONDITIONS OF MERCHANTABILITY, SATISFACTORY QUALITY, AND FITNESS FOR A PARTICULAR PURPOSE.
8. HP will be liable for damage to tangible property per incident up to the greater of \$300,000 or the actual amount paid for the product that is the subject of the claim, and for damages for bodily injury or death, to the extent that all such damages are determined by a court of competent jurisdiction to have been directly caused by a defective HP product.
9. TO THE EXTENT ALLOWED BY LOCAL LAW, THE REMEDIES IN THIS WARRANTY STATEMENT ARE THE CUSTOMER'S SOLE AND EXCLUSIVE REMEDIES. EXCEPT AS INDICATED ABOVE, IN NO EVENT WILL HP OR ITS SUPPLIERS BE LIABLE FOR LOSS OF DATA OR FOR DIRECT, SPECIAL, INCIDENTAL, CONSEQUENTIAL (INCLUDING LOST PROFIT OR DATA), OR OTHER DAMAGE, WHETHER BASED IN CONTRACT, TORT, OR OTHERWISE.



10. FOR CONSUMER TRANSACTIONS IN AUSTRALIA AND NEW ZEALAND; THE WARRANTY TERMS CONTAINED IN THIS STATEMENT, EXCEPT TO THE EXTENT LAWFULLY PERMITTED, DO NOT EXCLUDE, RESTRICT OR MODIFY AND ARE IN ADDITION TO THE MANDATORY STATUTORY RIGHTS APPLICABLE TO THE SALE OF THIS PRODUCT TO YOU.



## *Service During and After the Warranty Period*

- If printer hardware fails during the warranty period, contact an HP-authorized service or support provider. (See the [HP Customer Care](#) pages at the front of this user guide.)
- If printer hardware fails after the warranty period, and you have an HP Maintenance Agreement or HP SupportPack, request service as specified in the agreement.
- If you do not have an HP Maintenance Agreement or HP SupportPack, contact an HP-authorized service or support provider. (See the [HP Customer Care](#) pages at the front of this user guide.)





## Limited Warranty for Toner Cartridge Life



**Note** The warranty below applies to the toner cartridge that came with this printer.

This warranty supersedes all previous warranties (7/16/96).



This HP Toner Cartridge is warranted to be free from defects in materials and workmanship for cartridge life until the HP toner is depleted.



Your HP toner is depleted when your printer indicates a toner low message. HP will, at HP's option, either replace products which prove to be defective or refund your purchase price.

The warranty does not cover cartridges which have been refilled, are emptied, abused, misused, or tampered with in any way.

This limited warranty gives you specific legal rights. You may have other rights which vary from state to state, province to province, and country to country.

To the extent allowed by applicable law, in no event shall Hewlett-Packard Company be liable for any incidental, consequential, special, indirect, punitive, or exemplary damages or lost profits from any breach of this warranty or otherwise.



## HP Software License Terms

**ATTENTION: USE OF THE SOFTWARE IS SUBJECT TO THE HP SOFTWARE LICENSE TERMS SET FORTH BELOW. USING THE SOFTWARE INDICATES YOUR ACCEPTANCE OF THESE LICENSE TERMS. IF YOU DO NOT ACCEPT THESE LICENSE TERMS, YOU MAY RETURN THE SOFTWARE FOR A FULL REFUND. IF THE SOFTWARE IS BUNDLED WITH ANOTHER PRODUCT, YOU MAY RETURN THE ENTIRE UNUSED PRODUCT FOR A FULL REFUND.**

The following License Terms govern your use of the accompanying Software unless you have a separate signed agreement with HP.

### License Grant

HP grants you a license to Use one copy of the Software. “Use” means storing, loading, installing, executing, or displaying the Software. You may not modify the Software or disable any licensing or control features of the Software. If the Software is licensed for “concurrent use”, you may not allow more than the maximum number of authorized users to Use the Software concurrently.

### Ownership

The Software is owned and copyrighted by HP or its third party suppliers. Your license confers no title to, or ownership in, the Software and is not a sale of any rights in the Software. HP’s third party suppliers may protect their rights in the event of any violation of these License Terms.



### **Copies and Adaptations**

You may only make copies or adaptations of the Software for archival purposes or when copying or adaptation is an essential step in the authorized Use of the Software. You must reproduce all copyright notices in the original Software on all copies or adaptations. You may not copy the Software onto any public network.



### **No Disassembly or Decryption**

You may not disassemble or decompile the Software unless HP's prior written consent is obtained. In some jurisdictions, HP's consent may not be required for limited disassembly or decompilation. Upon request, you will provide HP with reasonably detailed information regarding any disassembly or decompilation. You may not decrypt the Software unless decryption is a necessary part of the operation of the Software.



### **Transfer**

Your license will automatically terminate upon any transfer of the Software. Upon transfer, you must deliver the Software, including any copies and related documentation, to the transferee. The transferee must accept these License Terms as a condition to the transfer.



### **Termination**

HP may terminate your license upon notice for failure to comply with any of these License Terms. Upon termination, you must immediately destroy the Software, together with all copies, adaptations, and merged portions in any form.



### **Export Requirements**

You may not export or reexport the Software or any copy or adaptation in violation of any applicable laws or regulations.



### **U.S. Government Restricted Rights**

The Software and any accompanying documentation have been developed entirely at private expense. They are delivered and licensed as “commercial computer software” as defined in DFARS 252.227-7013 (Oct 1988), DFARS 252.211-7015 (May 1991), or DFARS 252.227-7014 (Jun 1995), as a “commercial item” as defined in FAR 2.101 (a), or as “Restricted computer software” as defined in FAR 52.227-19 (Jun 1987) (or any equivalent agency regulation or contract clause), whichever is applicable. You have only those rights provided for such Software and any accompanying documentation by the applicable FAR or DFARS clause or the HP standard software agreement for the product involved.



# A Specifications



## Overview

This appendix includes:

- [Paper Specifications](#)
- [Printer Specifications](#)



## *Paper Specifications*

For HP Digital Copy paper specifications, see page [370](#).

HP LaserJet printers produce excellent print quality. This printer accepts a variety of media, such as cut-sheet paper (including recycled paper), envelopes, labels, transparencies, and custom-size paper. Properties such as weight, grain, and moisture content are important factors affecting printer performance and output quality.

The printer can use a variety of paper and other print media in accordance with the guidelines in this manual. Paper that does not meet these guidelines may cause the following problems:

- poor print quality
- increased paper jams and multiple-sheet feeds
- premature wear on the printer, requiring repair

**Continued on next page.**



---

**Note**

For best results, use only HP brand paper and print media. Hewlett-Packard Company cannot recommend the use of other brands. Because they are not HP products, HP cannot influence or control their quality.

It is possible for paper to meet all of the guidelines in this manual and still not produce satisfactory results. This might be the result of improper handling, unacceptable temperature and humidity levels, or other variables over which Hewlett-Packard has no control.

Before purchasing a large quantity of paper, make sure it meets the requirements specified in this user guide and in the *HP LaserJet Printer Family Paper Specification Guide*. (To order the guide, see page [50](#).) Always test paper before purchasing a large quantity.

---



---

**CAUTION**

Using paper outside HP specifications may cause problems for the printer, requiring repair. This repair is not covered by the Hewlett-Packard warranty or service agreements.

---

For supported sizes of paper, see page [392](#).



## Supported Sizes of Paper for Input and Output



**Note** For more information on an optional HP output device, see the user guide that came with the device.

Tray or Bin	Capacity	Paper	Weight
Tray 1 (multipurpose)	up to 100 sheets	<ul style="list-style-type: none"> <li>Paper sizes: Letter, ISO A4, Executive, ISO A5, Legal, 11 x 17, ISO A3, JIS B5, JIS B4, JPostD, 8K, 16K, JIS EXEC</li> <li>Custom sizes: Minimum: 3.9 x 7.5 in. (98 x 191 mm) Maximum: 11.7 x 17.7 in. (297 x 450 mm)</li> </ul>	16 to 53 lb Bond (60 to 199 g/m <sup>2</sup> )  Two-sided printing: 16 to 28 lb Bond (60 to 105 g/m <sup>2</sup> )
	up to 10 envelopes	<ul style="list-style-type: none"> <li>Envelope sizes: Commercial #10, C5, DL, Monarch, B5</li> </ul>	

**Note**  
Use Tray 1 when printing envelopes, transparencies, and labels.



<b>Tray or Bin</b>	<b>Capacity</b>	<b>Paper</b>	<b>Weight</b>
Tray 2 and Optional 2 x 500-sheet Input Tray (Tray 4)	up to 500 sheets	Paper sizes: Letter, ISO A4, Legal, JIS B4	16 to 28 lb (60 to 105 g/m <sup>2</sup> )
Tray 3 and Optional 2 x 500-sheet Input Tray (Tray 5)	up to 500 sheets	Paper sizes: Letter, ISO A4, Legal, JIS B4, ISO A3, 11 x 17	16 to 28 lb (60 to 105 g/m <sup>2</sup> )
Optional 2000-sheet Input Tray (Tray 4)	up to 2000 sheets	Paper sizes: Letter, ISO A4, Legal, JIS B4, ISO A3, 11 x 17	16 to 28 lb (60 to 105 g/m <sup>2</sup> )



Tray or Bin	Capacity	Paper	Weight
Optional Custom Paper Trays (Trays 3 or 5)	up to 500 sheets	<ul style="list-style-type: none"> <li>● Typical paper sizes: Letter, ISO A4, Legal, JIS B4, ISO A3, 11 x 17, 8K, 16K, JIS EXEC, Executive</li> <li>● Custom sizes: Minimum: 3.9 x 7.5 in. (98 x 191 mm) Maximum: 11.7 x 17.7 in. (297 x 450 mm)</li> </ul>	16 to 28 lb (60 to 105 g/m <sup>2</sup> )
Standard Output Bin (face-down)	up to 500 sheets	Paper sizes: Letter, ISO A4, ISO A5, Executive, Legal, 11 x 17, ISO A3, JIS B5, JIS B4, 8K, 16K, custom-size paper	
Face-up Bin	up to 100 sheets	Paper sizes: Letter, ISO A4, ISO A5, Executive, Legal, 11 x 17, ISO A3, JIS B5, JIS B4, JPostD, Monarch, 8K, 16K, envelopes, labels, transparencies, heavy paper, custom-size paper	



Tray or Bin	Capacity	Paper	Weight
5-bin Mailbox with Stapler and 8-bin Mailbox	up to 250 sheets per bin	Paper sizes: Letter, ISO A4, Legal <b>Note:</b> JIS B4, Executive, 11 x 17, ISO A3, envelopes, transparencies, and labels are only supported in the Face-up Bin. The staple bin only supports A4 and Letter paper sizes.	Standard Output Bin (Face-down Bin): 16 to 28 lb (60 to 105 g/m <sup>2</sup> )  Face-up Bin 16 to 53 lb (60 to 199 g/m <sup>2</sup> )
7-bin Tabletop Mailbox	up to 120 sheets per bin	Paper sizes: Letter, ISO A4, Legal <b>Note:</b> Envelopes, transparencies, and labels are only supported in the Face-up Bin.	Standard Output Bin (Face-down Bin): 16 to 28 lb (60 to 105 g/m <sup>2</sup> )  Face-up Bin 16 to 53 lb (60 to 199 g/m <sup>2</sup> )
Envelope Feeder	up to 100 envelopes	Envelope sizes: Commercial #10, C5, DL, Monarch, B5	16 to 24 lb (60 to 90 g/m <sup>2</sup> )



---

Tray or Bin	Capacity	Paper	Weight
Duplexer		Paper sizes: Letter, Legal, 11 x 17, Executive, ISO A3, ISO A4, ISO A5, JIS B4, JIS B5, 8K, 16K, JIS Exec	16 to 28 lb (60 to 105 g/m <sup>2</sup> )

---



## *Supported Types of Paper*

The printer allows the selection of the following types of paper through the control panel: (See the recommended paper specifications starting on page [390](#).)

- plain
- letterhead
- prepunched
- bond
- color
- rough
- preprinted
- transparency<sup>a</sup> (see page [405](#))
- labels<sup>a</sup> (see page [403](#))
- recycled
- card stock<sup>a</sup> (see page [410](#))
- user-defined (5 types)

a. Only supported in Tray 1.



## Guidelines for Using Paper

For best results, use conventional 20 lb (75 g/m<sup>2</sup>) paper. Make sure the paper is of good quality, and free of cuts, nicks, tears, spots, loose particles, dust, wrinkles, voids, and curled or bent edges.

If you are unsure what type of paper you are loading (such as bond or recycled), check the label on the package of paper.

Some paper causes print quality problems, jamming, or damage to the printer.



Symptom	Problem with Paper	Solution
Poor print quality or toner adhesion. Problems with feeding.	Too moist, too rough, too smooth, or embossed; faulty paper lot.	Consider variable fusing (see page <a href="#">160</a> ). Try another kind of paper, between 100-250 Sheffield, 4-6% moisture content.
Dropouts, jamming, curl.	Stored improperly.	Store paper flat in its moisture-proof wrapping.
Increased gray background shading.	Too heavy.	Use lighter paper. Use the Face-up Bin.



Symptom	Problem with Paper	Solution
Excessive curl. Problems with feeding.	Too moist, wrong grain direction or short-grain construction.	Use the Face-up Bin. Use long-grain paper.
Jamming, damage to printer.	Cutouts or perforations.	Do not use paper with cutouts or perforations.
Problems with feeding.	Ragged edges.	<a href="#">Use good quality paper.</a>



**Note**

Do not use letterhead paper that is printed with low-temperature inks, such as those used in some types of thermography.

Do not use raised letterhead.

The printer uses heat and pressure to fuse toner to the paper. Make sure that any colored paper or preprinted forms use inks that are compatible with the printer's fusing temperature (392° F or 200° C for 0.1 second).



### Paper Weight Equivalence Table

Use this table to determine approximate equivalent points in weight specifications other than U.S. bond weight. For example, to determine the equivalent of 20 lb U.S. bond weight paper in U.S. cover weight, locate the bond weight (in row 3, second column) and scan across the row to the cover weight (in the fourth column). The equivalent is 28 lb.

Shaded areas indicate a standard weight for that grade.



U.S. Post Card <sup>a</sup> thickness (mm)	U.S. Bond Weight (lb)	U.S. Text/ Book Weight (lb)	U.S. Cover Weight (lb)	U.S. Bristol Weight (lb)	U.S. Index Weight (lb)	U.S. Tag Weight (lb)	Europe Metric Weight (g/m <sup>2</sup> )	Japan Metric Weight (g/m <sup>2</sup> )
	16	41	22	27	33	37	60	60
	17	43	24	29	35	39	64	64
	20	50	28	34	42	46	75	75
	21	54	30	36	44	49	80	80
	22	56	31	38	46	51	81	81







U.S. Post Card <sup>a</sup> thickness (mm)	U.S. Bond Weight (lb)	U.S. Text/ Book Weight (lb)	U.S. Cover Weight (lb)	U.S. Bristol Weight (lb)	U.S. Index Weight (lb)	U.S. Tag Weight (lb)	Europe Metric Weight (g/m <sup>2</sup> )	Japan Metric Weight (g/m <sup>2</sup> )
	24	60	33	41	50	55	90	90
	27	68	37	45	55	61	100	100
	28	70	39	49	58	65	105	105
	32	80	44	55	67	74	120	120
	34	86	47	58	71	79	128	128
	36	90	50	62	75	83	135	135
.18	39	100	55	67	82	91	148	148
.19	42	107	58	72	87	97	157	157
.20	43	110	60	74	90	100	163	163
.23	47	119	65	80	97	108	176	176



<b>U.S. Post Card<sup>a</sup> thickness (mm)</b>	<b>U.S. Bond Weight (lb)</b>	<b>U.S. Text/ Book Weight (lb)</b>	<b>U.S. Cover Weight (lb)</b>	<b>U.S. Bristol Weight (lb)</b>	<b>U.S. Index Weight (lb)</b>	<b>U.S. Tag Weight (lb)</b>	<b>Europe Metric Weight (g/m<sup>2</sup>)</b>	<b>Japan Metric Weight (g/m<sup>2</sup>)</b>
	53	134	74	90	110	122	199	199

a. U.S. Post Card measurements are approximate. Use for reference only.



## *Labels*



**Note** For best results, use only Tray 1 and the Face-up Bin.



**CAUTION** To avoid damaging the printer, use only labels recommended for use in laser printers.

Never print on the same sheet of labels more than once.



Do not print on both sides of labels, transparencies, envelopes, custom paper, or paper heavier than 28 lb (105 g/m<sup>2</sup>). Damage to the printer and paper jamming might result.



## ***Label Construction***

When selecting labels, consider the quality of each component:

- **Adhesives:** The adhesive material should be stable at 392° F (200° C), the printer's maximum fusing temperature.
- **Arrangement:** Only use labels with no exposed backing between them. Labels can peel off sheets with spaces between the labels, causing serious jams.
- **Curl:** Prior to printing, labels must lie flat with no more than 0.5 inch (13 mm) of curl in any direction.
- **Condition:** Do not use labels with wrinkles, bubbles, or other indications of separation.

To print sheets of labels, see page [135](#).



## Transparencies



**Note** For best results, use only Tray 1 and the Face-up Bin.

**CAUTION** Transparencies used in the printer must be able to withstand 392° F (200° C), the printer's maximum fusing temperature. To avoid damaging the printer, use only transparencies recommended for use in laser printers.



Do not print on both sides of labels, transparencies, envelopes, custom paper, or paper heavier than 28 lb (105 g/m<sup>2</sup>). Damage to the printer and paper jamming might result.



If you have problems printing transparencies, use Tray 1.

To print transparencies, see page [137](#).



## Envelopes



**Note** For best results, use only Tray 1 or the envelope feeder and the Face-up Bin.



### *Envelope Construction*

Envelope construction is critical. Envelope fold lines can vary considerably, not only between manufacturers, but also within a box from the same manufacturer. Successful printing on envelopes depends upon the quality of the envelopes. When selecting envelopes, consider the following components:



- **Weight:** See page [395](#) for supported envelope weight.
- **Construction:** Prior to printing, envelopes should lie flat with less than 0.25 inch (6 mm) curl and should not contain air. (Envelopes that trap air may cause problems.)
- **Condition:** Make sure envelopes are not wrinkled, nicked, or otherwise damaged.
- **Sizes in Tray 1:** See page [392](#) for supported paper sizes.
- **Sizes in the optional envelope feeder:** See page [395](#) for supported envelope sizes.

Continued on next page.



If you do not have an optional envelope feeder, print envelopes from Tray 1, see page [130](#). To print envelopes with the optional envelope feeder, see page [123](#). If envelopes wrinkle, see page [260](#).



### ***Envelopes with Double-Side-Seams***

Double-side-seam construction has vertical seams at both ends of the envelope rather than diagonal seams. This style may be more likely to wrinkle. Be sure the seam extends all the way to the corner of the envelope as illustrated below.

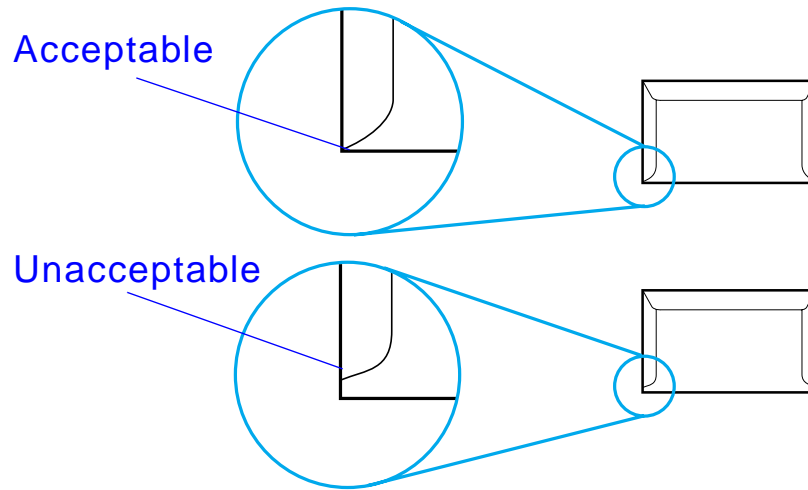

## ***Envelopes with Adhesive Strips or Flaps***

Envelopes with a peel-off adhesive strip or with more than one flap that folds over to seal must use adhesives compatible with the heat and pressure in the printer. The extra flaps and strips might cause wrinkling, creasing, or jams.



## ***Envelope Margins***

The following table gives typical address margins for a Commercial #10 or DL envelope.

<b>Type of Address</b>	<b>Top Margin</b>	<b>Left Margin</b>
Return Address	0.5 in. (15 mm)	0.6 in. (15 mm)
Delivery Address	2 in. (51 mm)	4 in. (85 mm)

**Note** For the best print quality, position margins no closer than 0.6 inch (15 millimeters) from the edges of the envelope.





## ***Envelope Storage***

Proper storage of envelopes helps contribute to good print quality. Envelopes should be stored flat. If air is trapped in an envelope, creating an air bubble, then the envelope may wrinkle during printing.



## Card Stock and Heavy Paper



**Note** For best results, use the Face-up Bin.

Many types of card stock, including postcards, can be printed from Tray 1. Some card stock performs better than others because its construction is better suited for feeding through a laser printer.



For optimum printer performance, do not use paper heavier than 53 lb (199 g/m<sup>2</sup>) in Tray 1 or 28 lb (105 g/m<sup>2</sup>) in other trays. Paper that is too heavy might cause misfeeds, stacking problems, paper jams, poor toner fusing, poor print quality, or excessive mechanical wear.



**Note** Printing on heavier paper may be possible if the tray is not filled to capacity, and paper with a smoothness rating of 100-180 Sheffield is used.



### ***Card Stock Construction***

- **Smoothness:** 36-53 lb (135-199 g/m<sup>2</sup>) card stock should have a smoothness rating of 100-180 Sheffield. 16-36 lb (60-135 g/m<sup>2</sup>) card stock should have a smoothness rating of 100-250 Sheffield.
- **Construction:** Card stock should lie flat with less than 0.2 inch (5 mm) of curl.
- **Condition:** Make sure card stock is not wrinkled, nicked, or otherwise damaged.
- **Sizes:** See page [392](#).



**Note**

Before loading card stock in Tray 1, make sure it is regular in shape and not damaged. Also, make sure the cards are not stuck together.

### ***Card Stock Guidelines***

Set margins at least 0.08 inch (2 mm) away from the edges of the paper.



# Printer Specifications



## Physical Dimensions

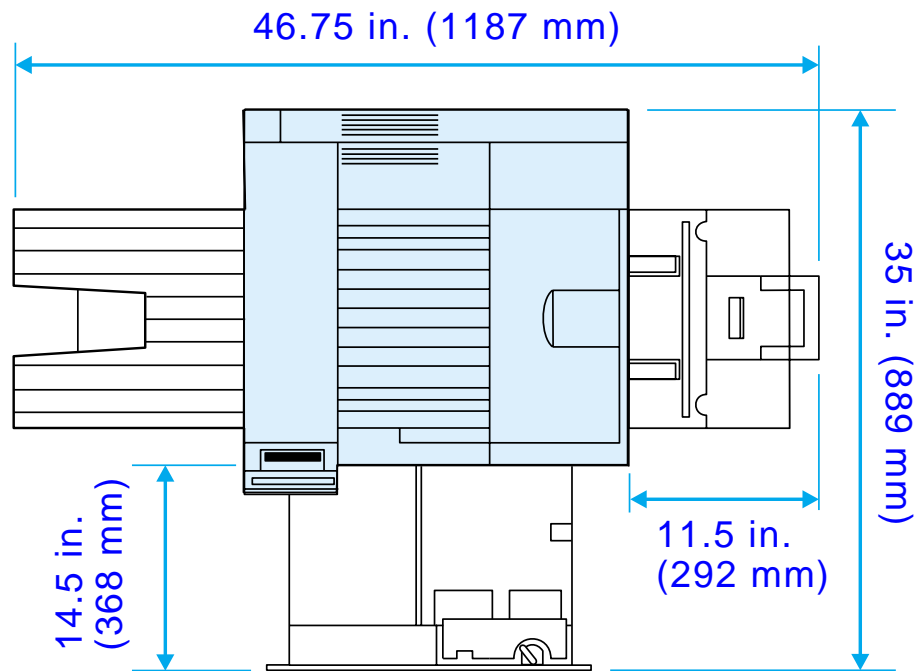

Continued on next page.



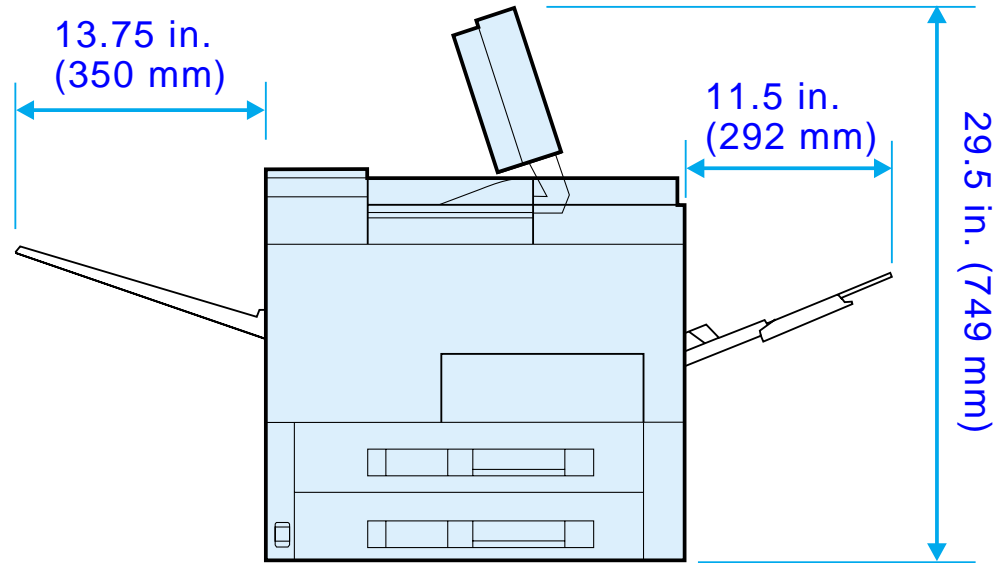

**Continued on next page.**



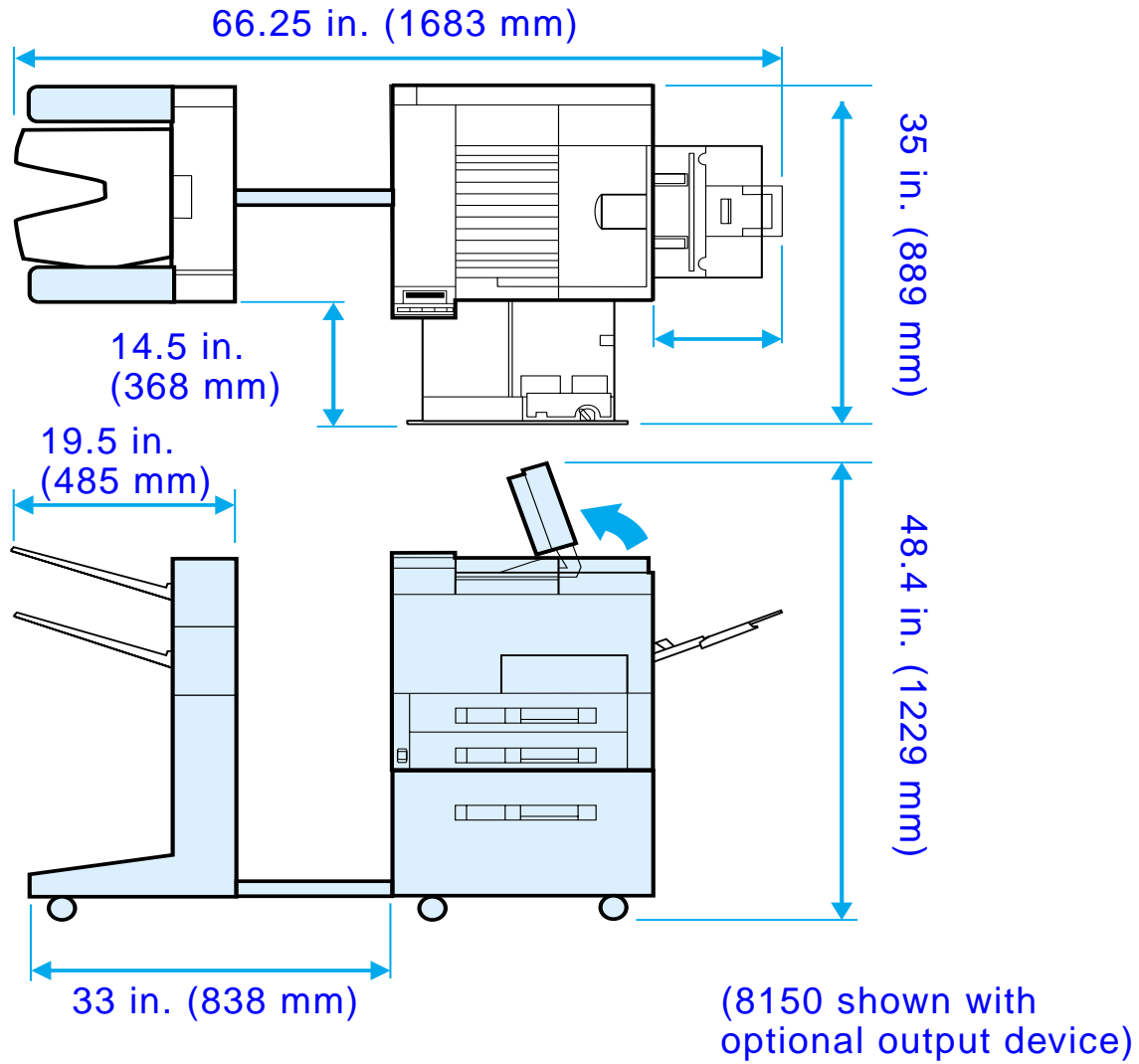

Continued on next page.

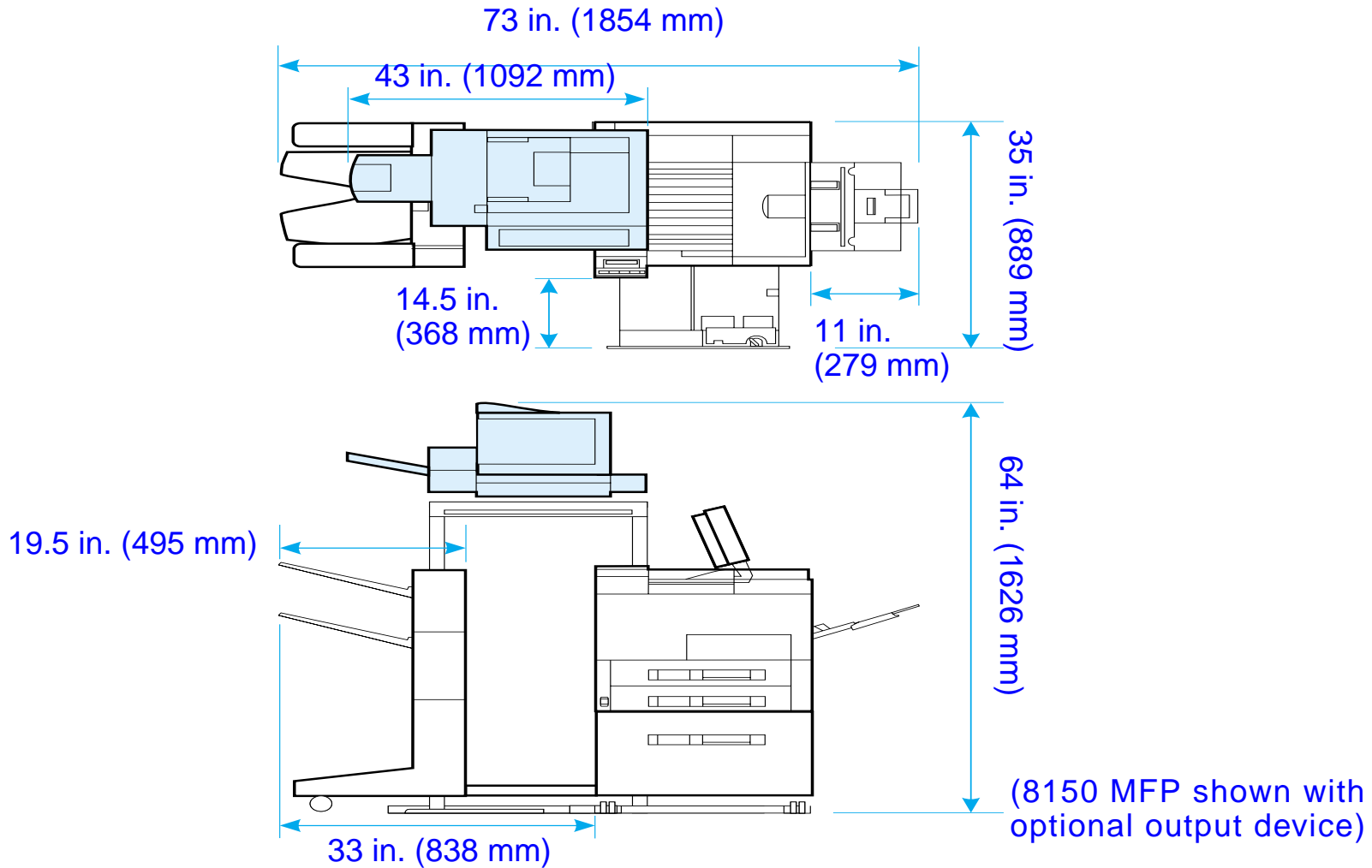

Continued on next page.

***Printer Weight (without toner cartridge)***

- HP LaserJet 8150 and 8150 N printers: 112 lbs (51 kg)
- HP LaserJet 8150 DN printer: 120 lbs (54 kg)
- HP LaserJet 8150 HN printer: 249 lbs (113 kg)
- HP LaserJet 8150 MFP printer: 300 lbs (136 kg)





## Environmental Specifications



Printer State	Power Consumption (average, in watts, base unit)	Power Consumption (average, in watts, fully configured unit)
Printing (100-127V units) (220-240V units)	645 Watts 655 Watts	685 Watts 685 Watts
Standby (100-127V units) (220-240V units)	145 Watts 145 Watts	160 Watts 165 Watts
PowerSave 1 (default activation time 30 minutes)	31 Watts 35 Watts	56 Watts (100-127V units) 61 Watts (220-240V units)
PowerSave 2 (default activation time 10 minutes after PowerSave 1 starts, if nothing else happens)	31 Watts 35 Watts	37 Watts (100-127V units) 40 Watts (220-240V units)





<b>Printer State</b>	<b>Power Consumption (average, in watts, base unit)</b>	<b>Power Consumption (average, in watts, fully configured unit)</b>
Off	0 Watts (100-127V units) 0.1 Watts (220-240V units)	0.5 Watts (100-127V units) 0.9 Watts (220-240V units)



**Minimum Recommended Circuit Capacity**

100-127 Volt	15.0 amps
220-240 Volt	6.5 amps

**Power Requirements (Acceptable Line Voltage)**

100-127 Volt (+/- 10%)	50-60 Hz (+/- 2 Hz)
220-240 Volt (+/- 10%)	50 Hz (+/- 2 Hz)
220 Volt (+/- 10%)	60 Hz (+/- 2 Hz)





	Operating (Printing) <sup>a</sup>		
Sound Power Level	6.9 Bel	5.2 Bel	inaudible
Sound Pressure Level, L <sub>pAm</sub> (Bystander Position)	53 dB	36 dB	inaudible
Sound Pressure Level, L <sub>pAm</sub> (Operator Position)	59 dB	41 dB	inaudible



a. Print speed is 32 ppm

Operating temperature	50-91° F (10-32.5° C)
Relative Humidity	20-80%
Speed, in pages per minute (ppm)	32 ppm
Expandable Memory	Up to 160 MB total, using optional accessory memory DIMMs.



# *B Control Panel Menus*



## *Overview*

You can perform most routine printing tasks from the computer through the printer driver or software application. This is the most convenient way to control the printer and will override the printer's control panel settings. See the help files associated with the software, or for more information on accessing the printer driver, see page [62](#).

You can also control the printer by changing settings in the printer's control panel. Use the control panel to access printer features not supported by the printer driver or software application.

---

### **Note**

Printer driver and software commands override the printer's control panel settings.

**Continued on next page.**



You can print a menu map from the control panel that shows the **current** printer configuration (page [317](#)).

This appendix lists all the items and **possible** values for the printer. (Default values are listed in the “Item” column.)

Additional menu items can appear in the control panel, depending on the options currently installed in the printer.



**Note**

For more information on an optional HP output device, see the user guide that came with the device.

This appendix includes:

- [Private/Stored Jobs Menu](#)
- [Information Menu](#)
- [Paper Handling Menu](#)
- [Print Quality Menu](#)
- [Printing Menu](#)
- [Configuration Menu](#)
- [Configuration of MBM Menu](#)

**Continued on next page.**



- [I/O Menu](#)
- [EIO Menu](#)
- [Resets Menu](#)



## Private/Stored Jobs Menu

This menu provides a list of the private, stored, quick copy, and proof and hold jobs on the printer's hard disk or RAM memory. The user can print or delete these jobs from the control panel. See [Job Retention](#) on page 166 for more information.



**Note** If there are no private, stored, quick copy, or proof and hold jobs on the printer's hard disk or RAM memory, this menu is not displayed on the control panel.

Item	Value	Explanation
[JOBNAME]		The name of the job stored on the printer's hard disk or in RAM.
PIN:0000		To print a private job, the user must enter the Personal Identification Number (PIN) assigned to the job in the driver.
COPIES=X	1 to 999 DELETE	The number of copies the user wants to print. 1-999: Prints the requested number of copies of the job. DELETE: Deletes the job from the printer's hard disk or RAM memory.



### Private/Stored Jobs Menu

## Information Menu

This menu contains printer information pages that give details about the printer and its configuration. To print an information page, scroll to the desired page and press **SELECT**.



Item	Explanation
PRINT MENU MAP	The menu map shows the layout and current settings of the control panel menu items. For more information, see page <a href="#">317</a> .
PRINT CONFIGURATION	The configuration page shows the printer's current configuration. If an HP JetDirect print server card is installed, a JetDirect configuration page will print out as well. For more information, see page <a href="#">314</a> .
PRINT PCL FONT LIST	The PCL font list shows all the PCL fonts currently available to the printer. For more information, see page <a href="#">318</a> .
PRINT PS FONT LIST	The PS font list shows all the PS fonts currently available to the printer. For more information, see page <a href="#">318</a> .





Item	Explanation
PRINT FILE DIRECTORY	This item appears only when a mass storage device (such as an optional flash DIMM or hard disk) containing a recognized file system is installed in the printer. The file directory shows information for all installed mass storage devices. For more information, see page <a href="#">320</a> .
PRINT EVENT LOG	The event log lists printer events or errors.  The second page of the event log is the manufacturing page. This page contains information that may assist HP Customer Care representatives in solving possible printer problems.
SHOW EVENT LOG	This item allows you to view the most recent printer events on the control panel display. Press - <b>VALUE</b> + to scroll through the event log entries.



Item	Explanation
PRINT PAPER PATH TEST	<p>The paper path test can be used to verify that various paper paths are working properly or to troubleshoot problems with tray configuration.</p> <p>Choose the input tray, output bin, duplexer (if available), and number of copies.</p> <p><b>Note</b> If a stapler is installed and is a valid destination, pressing <b>CANCEL JOB</b> to cancel the paper path test may not work as expected. In this case, press <b>Go</b>. When the printer stops printing and displays <b>OFFLINE</b>, turn the printer off, and then turn the printer on.</p>
PRINT USAGE PAGE	<p>The Usage Page contains information that could be used for cost accounting. This item will only show up if a hard disk is installed.</p>



## Paper Handling Menu

When paper handling settings are correctly configured through the control panel, you can print by choosing the type and size of paper from the printer driver or software application. For more information, see page [157](#).

Some items in this menu (such as duplex and manual feed) can be accessed from a software application or from the printer driver (if the appropriate driver is installed). Printer driver and software application settings override control panel settings. For more information, see page [146](#).



Item	Values	Explanation
ENV FEEDER SIZE=COM10	For supported envelope sizes, see page <a href="#">395</a> .	<p>This item appears only when the optional envelope feeder is installed. Set the value to correspond with the envelope size currently loaded in the envelope feeder.</p> <p><b>Note</b> The default indicated here is for 110V printers. The default envelope size for 220V printers is DL.</p>





Item	Values	Explanation
ENV FEEDER TYPE=PLAIN	For supported paper types, see page <a href="#">397</a> .	This item appears only when the optional envelope feeder is installed. Set the value to correspond with the envelope type currently loaded in the envelope feeder.
TRAY 1 MODE=FIRST	FIRST CASSETTE	Determine how the printer will use Tray 1.  FIRST: If paper is loaded in Tray 1, the printer will pull paper from that tray first.  CASSETTE: A paper size must be assigned to Tray 1 using the TRAY 1 SIZE option (the next item in this menu when TRAY 1 MODE= CASSETTE). This allows Tray 1 to be used as a reserved tray.  For more information, see page <a href="#">154</a> .
TRAY 1 SIZE=LETTER	For supported paper sizes, see page <a href="#">390</a> .	This item appears only when TRAY 1 MODE= CASSETTE. Set the value to correspond with the paper size currently loaded in Tray 1.
TRAY 1 TYPE=PLAIN	For supported paper types, see page <a href="#">397</a> .	This item appears only when TRAY 1 MODE= CASSETTE. Set the value to correspond with the paper type currently loaded in Tray 1.



Item	Values	Explanation
TRAY 2 TYPE=PLAIN	For supported paper types, see page <a href="#">397</a> .	Set the value to correspond with the paper type currently loaded in Tray 2.
TRAY 3 TYPE=PLAIN	For supported paper types, see page <a href="#">397</a> .	Set the value to correspond with the paper type currently loaded in Tray 3.
TRAY 4 TYPE=PLAIN	For supported paper types, see page <a href="#">397</a> .	This item appears only when a fourth paper tray is installed. Set the value to correspond with the paper type currently loaded in Tray 4.
TRAY 5 TYPE=PLAIN	For supported paper types, see page <a href="#">397</a> .	This item appears only when a fifth paper tray is installed. Set the value to correspond with the paper type currently loaded in Tray 5.
PAPER DEST=STANDARD OUTBIN	STANDARD OUTBIN FACE UP BIN OPTIONAL BIN x	OPTIONAL BIN x appears only when a mailbox is installed. Set the value to correspond with the appropriate bin.





Item	Values	Explanation
MANUAL FEED=OFF	OFF ON	<p>Feed the paper manually from Tray 1, rather than automatically from a tray. When MANUAL FEED=ON and Tray 1 is empty, the printer goes offline when it receives a print job and displays MANUALLY FEED [PAPER SIZE].</p> <p>For more information, see page <a href="#">156</a>.</p>
DUPLEX=OFF	OFF ON	<p>This item appears only when an optional duplexer is installed. Set the value to ON to print on both sides (duplex) or OFF to print on one side (simplex) of a sheet of paper.</p> <p>For more information, see page <a href="#">117</a>.</p>
BINDING= LONG EDGE	LONG EDGE SHORT EDGE	<p>This item appears only when an optional duplexer is installed and the duplex option is on. Choose the binding edge when duplexing (printing on both sides of paper).</p> <p>For more information, see page <a href="#">117</a>.</p>



Item	Values	Explanation
OVERRIDE A4/LETTER=NO	NO YES	Choose YES to print on letter size paper when an A4 job is sent, but no A4 size paper is loaded in the printer (or to print on A4 size paper when a letter job is sent, but no letter paper is loaded in the printer).
CONFIGURE FUSER MODE MENU=NO	NO YES	<p>Configure the fuser mode associated with each paper type. (This is only necessary if you are experiencing problems printing on certain paper types.)</p> <p>NO: The fuser mode menu items are not accessible.</p> <p>YES: Additional items appear (see [TYPE]=NORMAL on page <a href="#">433</a>).</p> <p>The fuser mode can only be changed from this menu option in the control panel.</p> <p><b>Note</b></p> <p>To see the default fuser mode for each paper type, select YES, scroll back to the Information Menu, and print a menu map (page <a href="#">424</a>).</p>

Item	Values	Explanation
CONFIGURE EDGE TO EDGE=NO	NO YES	<p>Configure the margin alignment for the tray you wish to print an edge-to-edge print job from.</p> <p>NO: The edge-to-edge configuration menu items are not accessible.</p> <p>YES: Additional edge-to-edge configuration menu items appear.</p>
PRINT TEST PAGE TRAY=ALL	ALL 1 2 3 4	<p>This item appears only when an external input paper handling device is installed.</p> <p>An edge-to-edge calibration page will print for the tray selected.</p>
TRAY X SHIFT=NONE	NONE LEFT 1 LEFT 2 LEFT 3 RIGHT 1 RIGHT 2 RIGHT 3	<p>Allows you to set a value that will shift the placement of an image to the left or right on the page.</p>





Item	Values	Explanation
[TYPE]=NORMAL	NORMAL LOW HIGH1 HIGH2 HIGH3	<p>This item appears only when CONFIGURE FUSER MODE MENU=YES. The printer speeds are for Letter or A4.</p> <p>NORMAL: Normal temperature, prints at 32 ppm.                      LOW: Low temperature, prints at 32 ppm.                      HIGH1: Raises the temperature, prints at 32 ppm.                      HIGH2: Raises the temperature, prints at 24 ppm.                      HIGH3: Raises the temperature, prints at 16 ppm.</p> <p>Most paper types are set to NORMAL by default. The exceptions are as follows:</p> <p>TRANSPRCY=LOW                      LABELS=HIGH1                      CARDSTOCK=HIGH2                      ROUGH=HIGH1</p>

**Continued on next page.**



---

Item	Values	Explanation
		For a complete list of supported paper types, see page <a href="#">397</a> .
		<b>CAUTION</b> If you change the fuser mode to HIGH1, HIGH2, or HIGH3, be sure to change it back to the default when you are done printing. Setting a paper type to HIGH1, HIGH2, or HIGH3 might shorten the life of some consumables, such as the fuser, and might cause other failures or jams.

---



## Print Quality Menu

Some items in this menu can be accessed from a software application or from the printer driver (if the appropriate driver is installed). Printer driver and software application settings override control panel settings. For more information, see page [146](#).



Item	Values	Explanation
RESOLUTION	300	Select the resolution from the following values:  <b>300:</b> Produces draft print quality at the printer's maximum speed (32 ppm). 300 dpi (dots per inch) is recommended for some bitmapped fonts and graphics, and for compatibility with the HP LaserJet III family of printers.  <b>600:</b> Produces high print quality at the printer's maximum speed (32 ppm).  <b>FASTRES 1200:</b> Produces optimum print quality (comparable to 1200 dpi) at the printer's maximum speed (32 ppm).  <b>Note</b> It is best to change the resolution from the printer driver or software application. (Driver and software settings override control panel settings.)
=FASTRES	600	
1200	FASTRES 1200	



Item	Values	Explanation
RET=MEDIUM	OFF LIGHT MEDIUM DARK	<p>Use the printer's Resolution Enhancement technology (REt) setting to produce print with smooth angles, curves, and edges.</p> <p>All print resolutions, including FastRes 1200, benefit from REt.</p> <p><b>Note</b> It is best to change the REt setting from the printer driver or software application. (Driver and software settings override control panel settings.)</p>





Item	Values	Explanation
ECONOMODE= OFF	OFF ON	<p>Turn EconoMode on (to save toner) or off (for high quality).</p> <p>EconoMode creates draft-quality printing by reducing the amount of toner on the printed page by up to 50%.</p> <p><b>CAUTION</b> HP does not recommend full-time use of EconoMode. (If EconoMode is used full-time, it is possible that the toner supply will outlast the mechanical parts in the toner cartridge.)</p> <p><b>Note</b> It is best to turn EconoMode on or off from the printer driver or software application. (Driver and software settings override control panel settings.)</p>
TONER DENSITY=3	1 2 3 4 5	<p>Lighten or darken the print on the page by changing the toner density setting. The settings range from 1 (light) to 5 (dark), but the default setting of 3 usually produces the best results.</p>



Item	Values	Explanation
CREATE CLEANING PAGE	No value to select.	Press <b>SELECT</b> to print a cleaning page (for cleaning excess toner from the paper path).  In order for the cleaning page to work properly, print the page on copier grade paper (not bond or rough paper). Follow the instructions on the cleaning page.
PROCESS CLEANING PAGE	No value to select.	This item appears only after a cleaning page has been generated (as described above).  Press <b>SELECT</b> to process the cleaning page.



## Printing Menu

Some items in this menu can be accessed from a software application, or from the printer driver (if the appropriate driver is installed). Printer driver and software application settings override control panel settings. For more information, see page [146](#).



Item	Values	Explanation
COPIES=1	1 to 999	Set the default number of copies by selecting any number from 1 to 999. Press - VALUE + once to change the setting by increments of 1, or hold down - VALUE + to scroll by increments of 10.  <b>Note</b> It is best to set the number of copies from the printer driver or software application. (Driver and software settings override control panel settings.)
CROSS FEED SIZE = INCHES or MILLIMETERS	INCHES MILLIMETERS	The size of the custom paper on the cross-feed side specified in inches or millimeters.  <b>Note</b> The feed direction is the direction that paper is fed through the printer. The cross-feed direction is perpendicular to the feed direction.



Item	Values	Explanation
PAPER=LETTER (110V printers) or PAPER=A4 (220V printers)	For supported paper sizes, see page <a href="#">392</a> .	Set the default image size for paper and envelopes. (The item name will change from paper to envelope as you scroll through the available sizes.)
and  ENVELOPE=COM10 (110V printers) or ENVELOPE=DL (220V printers)		
CONFIGURE CUSTOM PAPER=NO	NO YES	NO: The custom paper menu items are not accessible.  YES: The custom paper menu items appear (see below).





Item	Values	Explanation
UNIT OF MEASURE=INCHES (110V printers) or MILLIMETERS (220V printers)	INCHES MILLIMETERS	This item appears only when CONFIGURE CUSTOM PAPER=YES. Select the unit of measurement for the custom paper size.
X DIMENSION= 11.7 INCHES (110V printers) or 297 MILLIMETERS (220V printers)	For supported paper sizes, see page <a href="#">392</a> .	This item appears only when CONFIGURE CUSTOM PAPER=YES. Select the dimension to be fed into the printer (short edge).
Y DIMENSION= 17.7 INCHES (110V printers) or 450 MILLIMETERS (220V printers)	For supported paper sizes, see page <a href="#">392</a> .	This item appears only when CONFIGURE CUSTOM PAPER=YES. Select the other dimension (long edge).





Item	Values	Explanation
FORM=60 LINES (110V printers) or 64 LINES (220V printers)	5 to 128	Sets vertical spacing from 5 to 128 lines for default paper size. Press - VALUE + once to change the setting by increments of 1, or hold down - VALUE + to scroll by increments of 10.
ORIENTATION= PORTRAIT	PORTRAIT LANDSCAPE	Determine the default orientation of print on the page.  <b>Note</b> It is best to set the page orientation from the printer driver or software application. (Driver and software settings override control panel settings.)
PCL FONT SOURCE=INTERNAL	INTERNAL SOFT SLOT 1, 2, or 3	INTERNAL: Internal fonts. SOFT: Permanent soft fonts. SLOT 1, 2, or 3: Fonts stored in one of the three DIMM slots.
PCL FONT NUMBER=0	0 to 999	The printer assigns a number to each font and lists them on the PCL Font List (page <a href="#">318</a> ). The font number appears in the Font # column of the printout.



Item	Values	Explanation
PCL FONT PITCH=10.00	0.44 to 99.99	This item might not appear, depending on the font selected. Press - VALUE + once to change setting by increments of .01 for pitch, or hold down - VALUE + to scroll by increments of 1.
PCL FONT POINT SIZE=12.00	4.00 to 999.75	This item might not appear, depending on the font selected. Press - VALUE + once to change setting by increments of .25 for point size, or hold down - VALUE + to scroll by increments of 1.
PCL SYMBOL SET=PC-8	PC-8 many others	Select any one of several available symbol sets from the printer's control panel. A symbol set is a unique grouping of all the characters in a font. PC-8 or PC-850 is recommended for line draw characters.
COURIER=REGULAR	REGULAR DARK	<p>Select the version of Courier font to use:</p> <p>REGULAR: The internal Courier font available on the HP LaserJet 4 series printers.</p> <p>DARK: The internal Courier font available on the HP LaserJet III series printers.</p> <p>Both fonts are not available at the same time.</p>



Item	Values	Explanation
WIDE A4=NO	NO YES	<p>The Wide A4 setting changes the number of characters that can be printed on a single line of A4 paper.</p> <p>NO: Up to 78 10-pitch characters can be printed on one line.</p> <p>YES: Up to 80 10-pitch characters can be printed on one line.</p>
APPEND CR TO LF=NO	NO YES	<p>Select YES to append a carriage return to each line feed encountered in backward-compatible PCL jobs (pure text, no job control). Some environments, such as UNIX, indicate a new line using only the line feed control code. This option allows the user to append the required carriage return to each line feed.</p>
PRINT PS ERRORS=OFF	OFF ON	<p>Select ON to print the PS error page when PS errors occur.</p>
EDGE TO EDGE OVERRIDE=OFF	OFF ON	<p>Turns the edge-to-edge mode on or off for all print jobs. This mode can be overridden inside a print job by an edge-to-edge PJI variable.</p>



## Configuration Menu

Items in this menu affect the printer's behavior. Configure the printer according to your printing needs.



Item	Values	Explanation
POWERSAVE TIME= 30 MINUTES	15 MINUTES 30 MINUTES 1 HOUR 2 HOURS 3 HOURS	<p>The printer enters PowerSave after it has been idle for a specified amount of time. The PowerSave feature does the following:</p> <ul style="list-style-type: none"> <li>● Minimizes the amount of power consumed by the printer when it is idle.</li> <li>● Reduces wear on the printer's electronic components. (Turns off the display's backlight.)</li> <li>● When you send a print job, press a control panel key, open a paper tray, or open the top cover, the printer automatically comes out of PowerSave mode.</li> </ul> <p><b>Note</b> PowerSave turns off the backlight on the display, but the display is still readable.</p>



Item	Values	Explanation
PERSONALITY= AUTO	AUTO PCL PS	<p>Select the default printer language (personality). Possible values are determined by which valid languages are installed in the printer.</p> <p>Normally you should not change the printer language (the default is <code>AUTO</code>). If you change it to a specific printer language, the printer will not automatically switch from one language to another unless specific software commands are sent to the printer.</p>



Item	Values	Explanation
RESOURCE SAVE=OFF	OFF ON AUTO	<p>This item dedicates printer memory to save each language’s permanent resources. (You might need to add memory to the printer in order for this item to appear.) The amount of memory set aside can be different for each installed language. Some languages might have memory set aside for resource saving without requiring all languages to do so. Any time the amount of memory dedicated to a specific language is changed, all languages will lose all saved resources, including any unprocessed print jobs.</p> <p><b>OFF:</b> No language resource saving is performed, and language-dependent resources, such as fonts and macros, are lost when language or resolution changes.</p> <p><b>ON:</b> An item will appear for each installed language that allows the user to allocate a particular amount of memory to that language’s resource saving area. (See the items below.)</p> <p><b>AUTO:</b> The printer automatically determines the amount of memory to use for each installed language’s resource saving area.</p> <p>For more information, see page <a href="#">476</a>.</p>





Item	Values	Explanation
PCL MEMORY= 400K	0K and up  (This value depends on the amount of installed memory.)	This item appears only when RESOURCE SAVE=ON. Select the amount of memory used for saving PCL resources. Printer default is the minimum amount of memory needed to perform resource saving for PCL. Press - VALUE + to change settings by increments of 10 (up to 100 KB) or by increments of 100 (above 100 KB).  For more information, see page <a href="#">476</a> .

PS MEMORY= 400K	0K and up  (This value depends on the amount of installed memory.)	This item appears only when RESOURCE SAVE=ON. Select the amount of memory used for saving PS resources. Printer default is the minimum amount of memory needed to perform resource saving for PS. Press - VALUE + to change settings by increments of 10 (up to 100 KB) or by increments of 100 (above 100 KB).  For more information, see page <a href="#">476</a> .
-----------------	--	---







Item	Values	Explanation
PAGE PROTECT= AUTO	AUTO ON	<p>This item appears only after a 21 PAGE TOO COMPLEX, PRESS GO TO CONTINUE message displays (page <a href="#">243</a>).</p> <p>Memory Enhancement technology (MEt) attempts to guarantee that all pages will print. If the page does not print, turn PAGE PROTECT to ON. This might increase chances of a 20 INSUFFICIENT MEMORY, PRESS GO TO CONTINUE message. If this occurs, simplify the print job or install additional memory (page <a href="#">467</a>).</p>
CLEARABLE WARNINGS=JOB	JOB ON	<p>Set the amount of time that a clearable warning is displayed on the printer's control panel.</p> <p>JOB: Warning messages display on the control panel until the end of the job from which they were generated.</p> <p>ON: Warning messages display on the control panel until <b>Go</b> is pressed.</p>

Item	Values	Explanation
<p>AUTO CONTINUE=ON</p>	<p>ON OFF</p>	<p>This item determines how the printer reacts to errors.</p> <p><b>ON:</b> If an error occurs that prevents printing, the message will display, and the printer will go offline for 10 seconds before returning online.</p> <p><b>OFF:</b> If an error occurs that prevents printing, the message will remain on the display and the printer will remain offline until <b>Go</b> is pressed.</p> <p><b>Note</b> To stop printing when out of staples (when a stapler accessory is installed), set <code>AUTO CONTINUE=OFF</code> in the control panel Configuration Menu.</p>



Item	Values	Explanation
TONER LOW=CONTINUE	CONTINUE STOP	<p>This item determines how the printer behaves when toner is low. The TONER LOW message will first appear when the toner cartridge is almost out of toner. (About 100 to 300 sheets can still be printed.)</p> <p>CONTINUE: The printer will continue to print while the TONER LOW message is displayed.</p> <p>STOP: The printer will go offline and wait for further action.</p> <p>For more information, see page <a href="#">191</a>.</p>





Item	Values	Explanation
RAM DISK=AUTO	OFF ON AUTO	<p>This item determines how the RAM disk is configured. This item appears only if there is no optional hard disk installed and the printer has at least 12 MB of memory.</p> <p>OFF: The RAM disk is disabled.</p> <p>ON: The RAM disk is enabled. Configure the amount of memory to be used through the following item: RAM DISK SIZE.</p> <p><b>Note</b> If the setting is changed from OFF to ON or from OFF to AUTO, the printer will automatically reinitialize when it becomes idle.</p>
RAM DISK SIZE=xxxxK	0K and up  (This value depends on the amount of installed memory.)	<p>This item determines the size of the RAM disk. This item appears if RAM DISK=ON or AUTO.</p> <p>Press - VALUE + to change settings by increments of 100.</p> <p><b>Note</b> This setting cannot be changed if RAM DISK=AUTO. Changing this value will cause the printer to reinitialize when it becomes idle.</p>



Item	Values	Explanation
JAM RECOVERY= AUTO	AUTO ON OFF	<p>This item determines how the printer behaves when a paper jam occurs.</p> <p>AUTO: The printer automatically selects the best mode for printer jam recovery (usually ON). This is the default setting.</p> <p>ON: The printer automatically reprints pages after a paper jam is cleared.</p> <p>OFF: The printer does not reprint pages following a paper jam. Printing performance might be increased with this setting.</p>





Item	Values	Explanation
MAINTENANCE MESSAGE=OFF	OFF	<p>This item appears only after the PERFORM PRINTER MAINTENANCE message displays.</p> <p>OFF: The PERFORM PRINTER MAINTENANCE message will be cleared. If you do not replace the maintenance kit, the PERFORM PRINTER MAINTENANCE message will be displayed again after approximately 17,500 pages.</p> <p>The message should not be turned off unless the printer maintenance has been performed. If the required maintenance is not performed, the printer's performance will degrade. For more information, see page <a href="#">190</a>.</p>
NEW TONER CARTRIDGE=NO	YES NO	<p>This item allows the user to tell the printer that a new toner cartridge has been installed. Setting this item to YES will reset the HP TonerGauge to full.</p>
QUICK COPY JOBS=32	1 to 50	<p>Specifies the number of quick copy jobs that can be stored on the printer's hard disk.</p>



---

<b>Item</b>	<b>Values</b>	<b>Explanation</b>
JOB HELD TIMEOUT=OFF	OFF 1 HOUR 4 HOURS 1 DAY 1 WEEK	Sets the amount of time that quick copy, proof and hold, private, and stored jobs are kept before being automatically deleted from the queue.

---



## Configuration of MBM Menu

This menu defines the operating mode for the 7-bin Tabletop Mailbox, 8-bin Mailbox, or 5-bin Mailbox with Stapler.



Item	Value	Explanation
OPERATION MODE:	MAILBOX STACKER	Defines the operating mode for the multibin mailbox that is installed.
MAILBOX	JOB SEPARATOR COLLATOR	<p>MAILBOX: Each bin can be addressed individually as the destination and can have a name assigned to it by the network or printer administrator.</p> <p>STACKER: Stacks the output from the lowest bin to the top, regardless of job boundaries. This operating mode takes advantage of the total capacity of the bins. The software sees the multibin mailbox as one logical bin.</p> <p>JOB SEPARATOR: Automatically separates incoming jobs, which may have multiple copies, and assigns a bin to each. It uses all the bins, but the software sees the multibin mailbox as one logical bin. If a bin is full, the printer automatically sends the job to the next available bin.</p> <p>COLLATOR: Automatically separates mopies. Each mopy is delivered in consecutive bins, starting with the Face-up Bin.</p>





## I/O Menu

Items in the I/O (input/output) Menu affect the communication between the printer and the computer.



Item	Values	Explanation
I/O TIMEOUT=15	5 to 300	<p>Select the I/O timeout period in seconds. (I/O timeout refers to the time, measured in seconds, that the printer waits before ending a print job.)</p> <p>This setting allows you to adjust timeout for best performance. If data from other ports appear in the middle of your print job, increase the timeout value.</p> <p>Press - VALUE + once to change settings by increments of 1, or hold down - VALUE + to scroll by increments of 10.</p>



Item	Values	Explanation
I/O BUFFER=AUTO	AUTO ON OFF	<p>Allocate memory for I/O buffering.</p> <p><b>AUTO:</b> The printer automatically reserves memory for I/O buffering. Additional configurations are not required and the I/O BUFFER SIZE menu item does not appear.</p> <p><b>ON:</b> The I/O BUFFER SIZE item appears (see below). Specify the amount of memory to be used for I/O buffering.</p> <p><b>OFF:</b> I/O buffering is not performed and the I/O BUFFER SIZE item does not appear.</p> <p>When the I/O buffer setting is changed, any downloaded resources (such as fonts or macros) will need to be downloaded again, unless they are stored on an optional hard disk or flash DIMM.</p> <p>For more information, see page <a href="#">478</a>.</p>





Item	Values	Explanation
I/O BUFFER SIZE=100K	10K and up	<p>This item appears only when I/O BUFFER=ON. Specify the amount of memory for I/O buffering. The maximum amount of memory available for I/O buffering is determined by the amount of memory installed in the printer, the languages installed in the printer, and by other memory allocations that must be made.</p> <p>Press - VALUE + to change settings by increments of 10 (up to 100 KB) or by increments of 100 (above 100 KB).</p>
PARALLEL HIGH SPEED=YES	YES NO	<p>Select the speed at which data is transmitted to the printer.</p> <p>YES: The printer accepts faster parallel communications used for connections with newer computers.</p> <p>NO: The printer accepts slower parallel communications used for connections with older computers.</p>
PARALLEL ADV FUNCTIONS=ON	ON OFF	<p>Turn the bidirectional parallel communication on or off. The default is set for a bidirectional parallel port (IEEE-1284).</p> <p>This setting allows the printer to send status readback messages to the computer. (Turning the parallel advanced functions on might slow language switching.)</p>



## EIO Menu

EIO (enhanced input/output) Menus depend on the particular accessory product installed in an EIO slot of the printer. If the printer contains an HP JetDirect print server EIO card, you can configure basic networking parameters using the EIO Menu.



Item	Values	Explanation
CFG	NO	NO: The JetDirect Menu is not accessible.
NETWORK=NO	YES	YES: The JetDirect Menu appears.
IPX/SPX=ON	ON OFF	Select whether the IPX/SPX protocol stack (in Novell NetWare networks, for example) is enabled (on) or disabled (off).
DLC/LLC=ON	ON OFF	Select whether the DLC/LLC protocol stack is enabled (on) or disabled (off).
TCP/IP=ON	ON OFF	Select whether the TCP/IP protocol stack is enabled (on) or disabled (off).
ATALK=ON	ON OFF	Select whether the Apple EtherTalk protocol stack is enabled (on) or disabled (off).



Item	Values	Explanation
CFG	NO	NO: The IPX/SPX Menu is not accessible.
IPX/SPX=NO	YES	<p>YES: The IPX/SPX Menu appears. In the IPX/SPX Menu, you can specify the frame type parameter used on your network. The default is <code>AUTO</code>, to automatically set and limit the frame type to the one detected.</p> <p>For Ethernet cards, frame type selections include <code>EN_8023</code>, <code>EN_LII</code>, <code>EN_8022</code>, <code>EN_SNAP</code>.</p> <p>For Token Ring cards, frame type selections include <code>TR_8022</code>, <code>TR_SNAP</code>.</p> <p>In the IPX/SPX Menu for Token Ring cards, you can also specify NetWare Source Routing parameters, which include <code>SRC RT=AUTO</code> (default), <code>OFF</code>, <code>SINGLE R</code>, or <code>ALL RT</code>.</p>





Item	Values	Explanation
CFG LINK=NO	NO YES	<p>NO: The 10/100Base-TX link configuration menu will not be accessed.</p> <p>YES: Allows you to access and manually set 10/100Base-TX link parameters.</p> <ul style="list-style-type: none"> <li>● AUTO: (Default) The print server will automatically configure itself to match the network's link speed and communication mode.</li> <li>● 10T HALF: Sets 10 Mbps, Half-duplex operation on the print server.</li> <li>● 10T FULL: Sets 10 Mbps, Full-duplex operation on the print server.</li> <li>● 100TX HALF: Sets 100 Mbps, Half-duplex operation on the print server.</li> <li>● 100TX FULL: Sets 100 Mbps, Full-duplex operation on the print server.</li> </ul>



## Duplex Registration Menu

The items in this menu will assist you in aligning the images on the front and back of a duplexed page by calibrating the duplexer with trays 2, 3, or 4. For more information, see page [187](#).

You will need to repeat the following items for each tray.



Item	Explanation
TRAY n PRINT TEST PAGE	Print a test page for trays 2, 3, or 4 (a test page will print for tray 4 only if an external input device is attached).
TRAY n X= 0	0 is the X offset for the second side of the duplexed page for pages coming from tray n. The registration marks range from -5 to +5.
TRAY n Y= 0	0 is the Y offset for the second side of the duplexed page for pages coming from tray n. The registration marks range from -5 to +5.





## Resets Menu

Use this menu with caution. You can lose buffered page data or printer configuration settings when you select these items. Only reset the printer under the following circumstances:

- You want to restore the printer's default settings.
- Communication between the printer and computer has been interrupted.
- You are having problems with a port.

The items in the Resets Menu will clear all memory in the printer, while **CANCEL JOB** clears only the current job.



Item	Explanation
RESET MEMORY	<p>This item clears the printer buffer and the active I/O input buffer, and makes the control panel defaults current.</p> <p>Resetting memory during a print job can result in data loss.</p>



Item	Explanation
RESTORE FACTORY SETTINGS	<p>This item performs a simple reset and restores most of the factory (default) settings. This item also clears the input buffer for the active I/O.</p> <p>Resetting memory during a print job can result in data loss.</p> <p>This item does not affect network settings stored on the HP JetDirect print server (if installed).</p>
RESET ACTIVE I/O CHANNEL	<p>This item performs a simple reset and clears the input and output buffers (for the active I/Os only).</p> <p>Resetting memory during a print job can result in data loss.</p>
RESET ALL I/O CHANNELS	<p>This item performs a simple reset and clears the input and output buffers for all I/Os.</p>
POWERSAVE	<p>Allows PowerSave feature to be turned on or off.</p>





# *C Printer Memory and Expansion*

## *Overview*

The printer has three dual in-line memory module (DIMM) slots for upgrading with:

- More printer memory. DIMMs are available in 8, 16, 32, and 64 MB, for a maximum of 160 MB.
- Flash DIMMs, available in 2, 4, and 8 MB. Unlike standard printer memory, flash DIMMs can be used to permanently store downloaded items in the printer, even when the printer is off.
- DIMM-based accessory fonts, macros, and patterns.
- Other DIMM-based printer languages and printer options.

**Continued on next page.**



---

**Note** Single in-line memory modules (SIMMs) used on previous HP LaserJet printers are not compatible with this printer.

---



You might want to add more memory to the printer if you often do one or more of the following: print complex graphics or PS documents, print with the optional duplexer, use many downloaded fonts, and print large paper sizes (such as A3, B4, or 11 x 17).



The printer has three enhanced input/output (EIO) slots for expanding the printer's capabilities with:



- One or more network cards.
- A mass storage device, such as a hard disk.

For ordering information, see page [47](#).

To find out how much memory is installed in the printer or to find out what is installed in the EIO slots, print a configuration page (page [314](#)).

**Continued on next page.**



This appendix includes:

- [Determining Memory Requirements](#)
- [Installing Memory](#)
- [Checking Memory Installation](#)
- [Adjusting Memory Settings](#)
- [Installing EIO Cards/Mass Storage](#)



## *Determining Memory Requirements*

The amount of memory you need depends on the types of documents you print. Your print engine can print most text and graphics at 1200 dpi FastRes without additional memory.

Add memory to your printer if you:

- Commonly print complex graphics.
- Use many temporarily downloaded fonts.
- Print complex documents.
- Print two-sided documents.
- Use advanced functions (such as I/O Buffering and Resource Saving).
- Print PS documents



## Installing Memory

### CAUTION

Static electricity can damage dual in-line memory modules (DIMMs). When handling DIMMs, either wear an antistatic wrist strap or frequently touch the surface of the DIMM's antistatic package, then touch bare metal on the printer.

If you have not already done so, print a configuration page to find out how much memory is installed in the printer before adding more memory (page [314](#)).

- 1 Turn the printer off. Unplug the power cord and disconnect any cables.
- 2 Loosen the two captive thumb screws on the back of the printer.

Continued on next page.

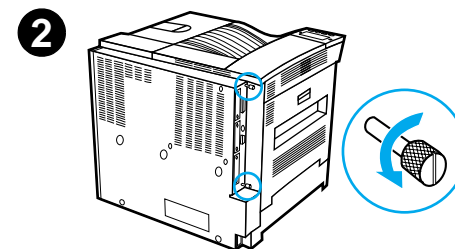
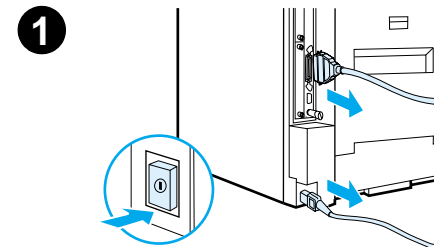

- 3 Grasp the screws and pull the formatter board out of the printer. Place it on a flat, non-conductive surface.
- 4 Remove the DIMM from the antistatic package. Hold the DIMM with fingers against the side edges and thumbs against the back edge. Align the notches on the DIMM with the DIMM slot. (Check that the locks on each side of the DIMM slot are open, or outward.)

See [Maximum Memory Configuration](#) on page [474](#) for the maximum amount of memory for each DIMM slot.

- 5 Press the DIMM straight into the slot (press firmly). Snap the locks on each side of the DIMM inward to secure the DIMM into the connector. (To remove a DIMM, the locks must be released.)

Continued on next page.

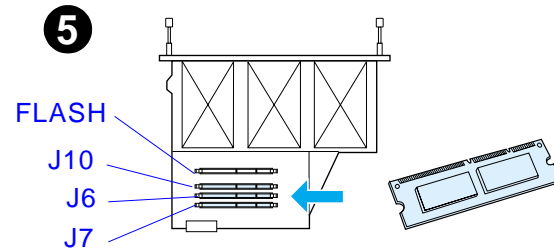
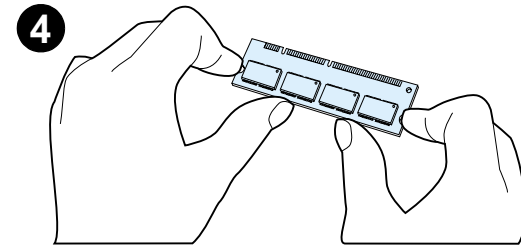
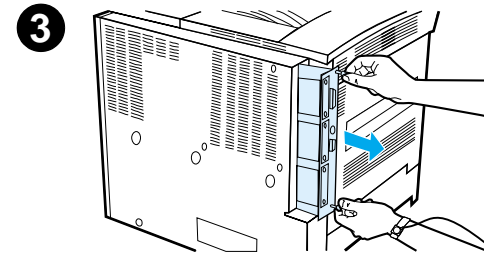



- 6 Slide the formatter board back into the printer and tighten the two screws.
- 7 Plug in the power cord and connect all cables. Turn the printer on.

**Continued on next page.**

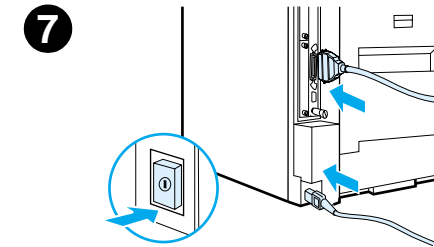
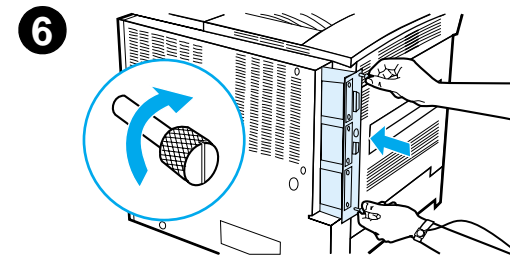

**Maximum Memory Configuration**



Configuration Page Label	Formatter Board Label	Description
Slot 1	FLASH	Flash firmware
Slot 2	J10	32 MB
Slot 3	J6	64 MB
Slot 4	J7	64 MB
Total		160 MB



**Installing Memory**

## Checking Memory Installation

Follow this procedure to verify that DIMMs are installed correctly:

- 1 Check that the printer's control panel displays `READY` when the printer is turned on. If an error message appears, a DIMM might have been incorrectly installed. Check the printer messages (beginning on page [227](#)).
- 2 Print a new configuration page (page [314](#)).
- 3 Check the memory section on the configuration page and compare it to the configuration page printed before the DIMM installation. If the amount of memory has not increased, the DIMM might not be installed correctly (repeat the installation procedure) or the DIMM might be defective (try a new DIMM, or try installing the DIMM in a different slot).



---

### Note

If you installed a printer language (personality), check the Installed Personalities and Options section on the configuration page. This area should list the new printer language.

---



## Adjusting Memory Settings



### *Resource Saving*

Resource Saving allows the printer to keep downloaded resources (permanent downloaded fonts, macros, or patterns) in memory when the printer language or resolution is changed.

If you do not have an optional hard disk or flash DIMM for storing downloaded resources, you might want to change the amount of memory allocated to each language when downloading an unusually large number of fonts, or if the printer is in a shared environment.

The minimum amount of memory that can be allocated to Resource Saving is 400 KB each for PCL and PS.

To determine how much memory to allocate to a language:

- 1 From the Configuration Menu, set `RESOURCE SAVE=ON` (page [448](#)). You might need to add memory to the printer in order for this option to appear in the printer's control panel.

**Continued on next page.**



- 2 Also from the Configuration Menu, choose either PCL MEMORY or PS MEMORY and change the setting to the highest value displayed. This amount will vary depending upon how much memory is installed in the printer.
- 3 Using a software application, download all the fonts you want to use in the selected language.
- 4 Print a configuration page (page [314](#)). The amount of memory used by the fonts is listed next to the language. Round this figure up to the nearest 100 KB. (For example, if 475 KB are shown, 500 KB should be reserved.)
- 5 From the Configuration Menu, set PCL MEMORY or PS MEMORY to the value determined in step 4.
- 6 Repeat step 3. (You must download all fonts again. See the note below.)



---

**Note**

When you change the Resource Saving setting, all downloaded resources (such as fonts or macros) will need to be downloaded again, unless they are stored on an optional hard disk or flash DIMM.

---



## ***I/O Buffering***

To allow the computer to continue working without waiting for the print job to finish queuing, the printer uses a portion of its memory (an I/O buffer) to hold jobs in progress. (If I/O buffering is off, no memory is reserved for this function.)

In most cases, it is best to let the printer automatically reserve memory for I/O buffering.

To speed network printing, you might want to increase the amount of memory reserved for I/O buffering.

To change the I/O Buffer setting:

- 1 From the I/O Menu, set I/O BUFFER=ON (page [457](#)).
- 2 Also from the I/O Menu, set I/O SIZE to the desired value.



---

### **Note**

When you change the I/O Buffer setting, all downloaded resources (such as fonts or macros) will need to be downloaded again, unless they are stored on an optional hard disk or flash DIMM.

---



## Installing EIO Cards/Mass Storage

Turn off the printer before installing the EIO cards or mass storage device.

See the graphic below for orientation and location of the EIO cards or optional mass storage device, such as a hard disk.

Use HP LaserJet Resource Manager to manage fonts on a mass storage device (page [86](#)). For more information, see the printer software help.

HP is constantly introducing new software tools for use with your printer and accessories. These tools are available from the Internet free of charge. See page [3](#) for how to visit the HP website for more information.

After you have installed a new device, print a configuration page.

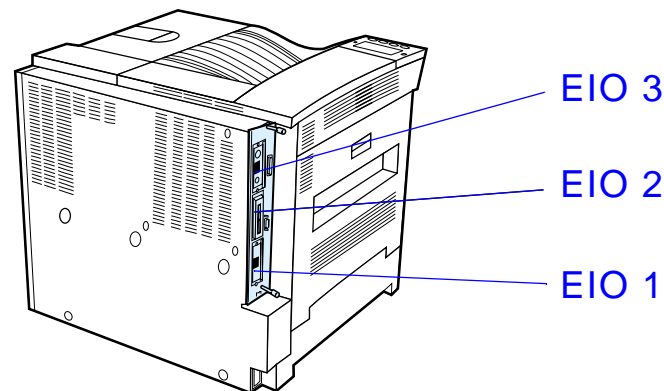

# *D Printer Commands*



## *Overview*

Most software applications do not require you to enter printer commands. See your computer and software documentation to find the method for entering printer commands, if needed.

## *PCL*

PCL printer commands tell the printer which tasks to perform or which fonts to use. This appendix provides a quick reference for users who are already familiar with PCL command structure.

---

### **Note**

Unless PCL 5e backward compatibility is required, HP recommends that PCL 6 printer drivers be used to take full advantage of all printer features. The PCL 5e printer driver in this printer is not backward compatible with older printers that use PCL 5e printer drivers.

---





## ***HP-GL/2***

The printer has the ability to print vector graphics using the HP-GL/2 graphics language. Printing in the HP-GL/2 language requires that the printer leave PCL language and enter HP-GL/2 mode, which can be done by sending the printer PCL code. Some software applications switch languages through their drivers.



## ***PJL***

HP's Printer Job Language (PJL) provides control above PCL and other printer languages. The four major functions provided by PJL are: printer language switching, job separation, printer configuration, and status readback from the printer. PJL commands may be used to change printer default settings.

This appendix includes:

- [Understanding PCL Printer Command Syntax](#)
- [Selecting PCL Fonts](#)
- [Common PCL Printer Commands](#)

**Continued on next page.**



**Note**

The table at the end of this appendix contains commonly used PCL 5e commands (page [486](#)). For a complete listing and explanation of how to use PCL, HP-GL/2, and PJP commands, order the *PCL 5/PJP Technical Reference Documentation Package* (page [51](#)).



# Understanding PCL Printer Command Syntax



Before using printer commands, compare these characters:

Lowercase l:	<i>l</i>	Uppercase O:	O
Number one:	1	Number 0:	0



Many printer commands use the lowercase letter l (*l*) and the number one (1), or the uppercase letter O (O) and the number zero (0). These characters may not appear on your screen as shown here. You must use the exact character and case specified for PCL printer commands.



**Escape character**  
(begins escape sequence)

**Value field** (contains both  
alpha and numeric characters)

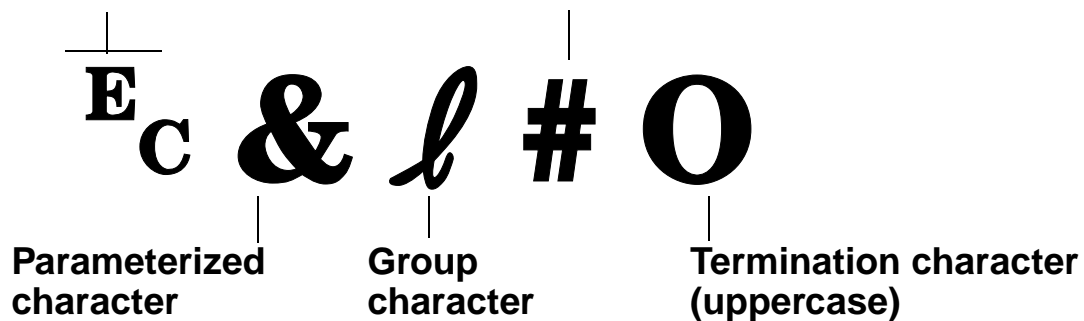

## Combining Escape Sequences

Escape sequences may be combined into one escape sequence string. There are three important rules to follow when combining code:

- 1 The first two characters after the  $E_C$  character (the parameterized and group characters) must be the same in all of the commands to be combined.
- 2 When combining escape sequences, change the uppercase (termination) character in each individual escape sequence to lower case.
- 3 The final character of the combined escape sequence must be uppercase.

The following is an example of an escape sequence string that would be sent to the printer to select legal paper, landscape orientation, and 8 lines per inch:

```
 $E_C$ &l3A $E_C$ &l1O $E_C$ &l8D
```

The following escape sequence sends the same printer commands by combining them into a shorter sequence:

```
 $E_C$ &l3a1o8D
```



## Selecting PCL Fonts

Print a PCL Font List to view the command for each internal font (page [318](#)). A sample section is shown below. Notice the two variable boxes for symbol set and point size.

Univers Medium                      Scale                      <esc>(  <esc>(s1p  v0s0b4148T                      | 01

These variables must be filled in or the printer will use defaults. For example, if you want a symbol set that contains line-draw characters, select the 10U (PC-8) or 12U (PC-850) symbol set. Other common symbol set codes are listed in the table on page [491](#).

---

### Note

Fonts are either “fixed” or “proportional” in spacing. The printer contains both fixed fonts (Courier, Letter Gothic, and Lineprinter) and proportional fonts (CG Times, Arial, Times New Roman, and others).

Fixed-spaced fonts are generally used in applications such as spreadsheets and databases, where it is important for columns to line up vertically. Proportional-spaced fonts are generally used in text and word processing applications.

---



## Common PCL Printer Commands



Function	Command	Options (#)
<b>Job Control Commands</b>		
Reset	$\text{E}_c\text{E}$	n/a
Number of Copies	$\text{E}_c\&l\#X$	1 to 999
2-sided/1-sided printing	$\text{E}_c\&l\#S$	0 = Simplex (1-sided) printing 1 = Duplex (2-sided) with long edge binding 2 = Duplex (2-sided) with short edge binding



---

<b>Function</b>	<b>Command</b>	<b>Options (#)</b>
-----------------	----------------	--------------------

---



**Page Control Commands**

Paper Source	$\text{E}_c \& l \# H$	0 = prints or ejects current page 1 = Tray 2 2 = manual feed, paper 3 = manual feed, envelope 4 = Tray 1 5 = Tray 3 6 = Envelope Feeder 7 = auto select 20 = Tray 4 21 = Tray 5 22-69 = external trays
--------------	------------------------	--



Function	Command	Options (#)
Paper size	$E_C \& l \#A$	1 = Executive 2 = Letter 3 = Legal 6 = 11 x 17 17 = 16K 18 = JIS EXEC 19 = 8K 25 = A5 26 = A4 27 = A3 44 = B6-JIS 45 = B5-JIS 46 = B4-JIS 72 = Postcard (double) 80 = Monarch 81 = Commercial 10 90 = DL 91 = International C5 100 = B5 101 = Custom





Function	Command	Options (#)
Paper Type	E <sub>C</sub> &n#	5WdBond = Bond 6WdPlain = Plain 6WdColor = Color 7WdLabels = Labels 9WdRecycled = Recycled 11WdLetterhead = Letterhead 10WdCardstock = Cardstock 11WdPrepunched = Prepunched 11WdPreprinted = Preprinted 13WdTransparency = Transparency #WdCustompapertype = Custom <sup>a</sup>
Orientation	E <sub>C</sub> &l#O	0 = Portrait 1 = Landscape 2 = Reverse Portrait 3 = Reverse Landscape
Top Margin	E <sub>C</sub> &l#E	# = number of lines
Text Length (bottom margin)	E <sub>C</sub> &l#F	# = number of lines from top margin
Left Margin	E <sub>C</sub> &a#L	# = column number





Function	Command	Options (#)
Right Margin	$\text{E}_C\&a\#M$	# = column number from left margin
Horizontal Motion Index	$\text{E}_C\&k\#H$	1/120-inch increments (compresses print horizontally)
Vertical Motion Index	$\text{E}_C\&l\#C$	1/48-inch increments (compresses print vertically)
Line Spacing	$\text{E}_C\&l\#D$	# = lines per inch (1, 2, 3, 4, 5, 6, 12, 16, 24, 48)
Perforation Skip	$\text{E}_C\&l\#L$	0 = disable 1 = enable



**Programming Hints**

End of Line Wrap	$\text{E}_C\&s\#C$	0 = Enable 1 = Disable
Display Functions On	$\text{E}_C Y$	n/a
Display Functions Off	$\text{E}_C Z$	n/a



Function	Command	Options (#)
<b>Language Selection</b>		
Enter PCL Mode	$\text{E}_C\%#A$	0 = Use previous PCL cursor position 1 = Use current HP-GL/2 pen position
Enter HP-GL/2 Mode	$\text{E}_C\%#B$	0 = Use previous HP-GL/2 pen position 1 = Use current PCL cursor position
<b>Font Selection</b>		
Symbol Sets <sup>b</sup>	$\text{E}_C(\#$	8U = HP Roman-8 Symbol Set 10U = IBM Layout (PC-8) (code page 437) Default Symbol Set 12U = IBM Layout for Europe (PC-850) (code page 850) 8M = Math-8 19U = Windows 3.1 Latin 1 9E = Windows 3.1 Latin 2 (commonly used in Eastern Europe) 5T = Windows 3.1 Latin 5 (commonly used in Turkey) 579L = Wingdings Font



<b>Function</b>	<b>Command</b>	<b>Options (#)</b>
Primary Spacing	E <sub>C</sub> (s#P	0 = fixed 1 = proportional
Primary Pitch	E <sub>C</sub> (s#H	# = characters/inch
Set Pitch Mode <sup>c</sup>	E <sub>C</sub> &k#S	0 = 10 4 = 12 (elite) 2 = 16.5 - 16.7 (compressed)
Primary Height	E <sub>C</sub> (s#V	# = points
Primary Style <sup>b</sup>	E <sub>C</sub> (s#S	0 = upright (solid) 1 = italic 4 = condensed 5 = condensed italic
Primary Stroke Wt. <sup>b</sup>	E <sub>C</sub> (s#B	0 = medium (book or text) 1 = semi bold 3 = bold 4 = extra bold



Function	Command	Options (#)
Typeface <sup>b</sup>	E <sub>c</sub> (s#T	Print a PCL font list to view the command for each internal font (page <a href="#">318</a> ).

a. For custom paper, replace “Custompapertype” with the name of the paper, and replace the “#” with the number of characters in the name plus 1.  
 b. Order the *PCL 5/PJL Technical Reference Documentation Package* for symbol set charts or for more information (page [51](#)).  
 c. The preferred method is to use the primary pitch command.



# *E Regulatory Information*



## *Overview*

- [FCC Regulations](#)
- [Environmental Product Stewardship](#)
- [Safety Statements](#)



## *FCC Regulations*

This equipment has been tested and found to comply with the limits for a Class B digital device, pursuant to Part 15 of the FCC rules. These limits are designed to provide reasonable protection against harmful interference in a residential installation. This equipment generates, uses, and can radiate radio frequency energy. If this equipment is not installed and used in accordance with the instructions, it may cause harmful interference to radio communications. However, there is no guarantee that interference will not occur in a particular installation. If this equipment does cause harmful interference to radio or television reception, which can be determined by turning the equipment off and on, the user is encouraged to try to correct the interference by one or more of the following measures:

- Reorient or relocate the receiving antenna.
- Increase separation between equipment and receiver.
- Connect equipment to an outlet on a circuit different from that to which the receiver is located.
- Consult your dealer or an experienced radio/TV technician.

**Continued on next page.**



---

**Note**

Any changes or modifications to the printer that are not expressly approved by HP could void the user's authority to operate this equipment.



Use of a shielded interface cable is required to comply with the Class B limits of Part 15 of FCC rules.



---

**Note**

The HP LaserJet 8150 MFP, or any model of HP LaserJet 8150 printer with an HP Digital Copy attached, complies with Class A limits.





## Environmental Product Stewardship



### Protecting the Environment

Hewlett-Packard Company is committed to providing quality products in an environmentally-sound manner. The printer has been designed to minimize impacts on the environment.



---

#### The printer design eliminates:

<b>Ozone Production</b>	The printer uses charging rollers in the electrophotographic process and therefore generates no appreciable ozone gas (O <sub>3</sub> ).
<b>CFC Usage</b>	Class I U.S. Clean Air Act stratospheric ozone-depleting chemicals (chlorofluorocarbons [CFCs], for example) have been eliminated from the manufacturing of the printer and packaging.



---

**The printer design reduces:**

**Energy Consumption**

Energy usage drops from 685/685 (110V/220V units) watts (W) during printing to as little as 37/40 (110V/220V units) W while in inactive, PowerSave mode. This saves energy without affecting the high performance of the printer. This product qualifies for the ENERGY STAR Program (U.S. and Japan). ENERGY STAR is a voluntary program established to encourage the development of energy-efficient office products. The ENERGY STAR name is a registered service mark of the U.S. Environmental Protection Agency.

As an ENERGY STAR partner, Hewlett-Packard Company has determined that this product meets ENERGY STAR Guidelines for energy efficiency.



**Toner Consumption**

EconoMode uses about 50% less toner, thereby extending the life of the toner cartridge. (HP does not recommend full-time use of EconoMode.)

**Paper use**

The printer's optional duplexing feature, which provides for two-sided printing, reduces paper usage and the resulting demands on natural resources.



---

**The design of the printer facilitates the recycling of:**



**Plastics**

Plastic parts have material identification markings, according to international standards, that enhance the ability to identify plastics for proper disposition at the end of the printer's life.



**HP LaserJet  
Printing  
Supplies**

In many countries/regions, this product's printing supplies (for example, toner cartridge or fuser) can be returned to HP through the HP Planet Partners Printing Supplies Environmental Program. An easy-to-use and free takeback program is available in over 25 countries/regions. Multi-lingual program information and instructions are included in every new HP LaserJet Toner Cartridge and Consumables package.



**Continued on next page.**



---

### HP Planet Partners Printing Supplies Environmental Program Information

Since 1990, the HP LaserJet Toner Cartridge Recycling Program has collected more than thirty-one million used LaserJet toner cartridges that otherwise may have been discarded in the world's landfills. The HP LaserJet toner cartridges go to a collection center and are bulk-shipped to our recycling partners who disassemble the cartridge parts for recycling. Materials are separated and converted into raw materials for use by other industries to make a variety of useful products.

For more information on the Planet Partners program, please contact your local sales office.



### Paper

The printer is suited for the use of recycled papers when the paper meets the guidelines outlined in the *HP LaserJet Printer Family Paper Specifications Guide*.



---

**To ensure printer longevity, HP provides the following:**



**Extended  
Warranty**

HP SupportPack covers the printer and all HP-supplied internal components. It is a three-year warranty from the date of purchase. HP SupportPack must be purchased by the customer within 90 days of product purchase. (See the [HP Customer Care](#) pages at the front of this user guide.)



**Spare Parts and  
Consumables  
Availability**

Spare parts and consumable supplies for this product will be made available for at least five years after production has stopped.



## *Material Safety Data Sheet*

The Toner Cartridge/Drum material data safety sheet (MSDS) can be obtained by accessing the URL <http://www.hp.com/go/msds> and selecting the HP LaserJet icon. If you do not have access to the Internet, call U.S. HP FIRST (fax-on-demand service) at 1-800-231-9300. Use Index number 7 for a listing of the Toner Cartridge/Drum Material/Chemical Safety Data Sheets. Non-U.S. Customers should call 1-404-329-2009 for further information.



## Environmental Conformity



---

**Plastics** Plastic parts have material identification markings, according to international standards, that enhance the ability to identify plastics for proper disposition at the end of the printer's life. The plastics used in the printer housing and chassis are technically recyclable.



**Printer and Parts** Design for recycling has been incorporated into the printer and its accessories. The number of materials has been kept to a minimum while ensuring proper functionality and high product reliability. Dissimilar materials have been designed to separate easily. Fasteners and other connections are easy to locate, access, and remove with common tools. High priority parts have been designed to be accessed quickly for efficient disassembly and repair. Plastic parts have been primarily designed in two colors to enhance recycling options. A few small parts are colored specifically to highlight customer access points.



**Continued on next page.**



---

**Printer and Parts  
(continued)**

HP disposes of returned products in an environmentally sound manner. Many of the functional parts are recovered, tested, and reused as fully-warrantied service parts. Used printer parts are not placed into new product manufacturing. The remainder of the product parts are recycled, if possible. For product recycling information, contact your local [HP Customer Care](#) center (page 3).



**Paper**

The printer is suited for the use of recycled papers when the paper meets the guidelines outlined in the *HP LaserJet Printer Family Paper Specifications Guide*. The printer is suited for the use of recycled paper according to DIN 19 309.



---

## *Declaration of Conformity*

according to ISO/IEC Guide 22 and EN45014

**Manufacturer's Name:** Hewlett-Packard Company

**Manufacturer's Address:** 11311 Chinden Boulevard

Boise, Idaho 83714-1021, USA





---

**declares, that the product**



**Product Name:** HP LaserJet 8150, 8150 N, 8150 DN, 8150 HN, 8150 MFP<sup>3</sup>



**Model Number:** C4265A, C4266A, C4267A, C4268A, C4269A

**Product Options:** ALL



**conforms to the following Product Specifications:**

**Safety:** IEC 950:1991+A1+A2+A3+A4 / EN 60950:1992+A1+A2+A3+A4  
IEC 825-1:1993 / EN 60825-1:1994 Class 1 (Laser/LED)

**EMC:** EN 55022:1998 (Class B <sup>1, 3</sup>)

EN 55024:1998

EN 61000-3-2:1995

EN 61000-3-3:1995



---

FCC Title 47 CFR, Part 15 (Class B<sup>2, 3</sup>) / ICES-002, Issue 2

AS / NZS 3548:1995



**Supplementary Information:**

The product herewith complies with the requirements of the EMC Directive 89/336/EEC and the Low Voltage Directive 73/23/EEC, and carries the CE-marking accordingly.

1) The product was tested in a typical configuration with Hewlett-Packard Personal Computer Systems.

2) This Device complies with Part 15 of the FCC Rules. Operation is subject to the following two conditions: (1) this device may not cause harmful interference, and (2) this device must accept any interference received, including interference that may cause undesired operation.

3) The HP LaserJet 8150 MFP, or any model of HP LaserJet 8150 printer with an HP Digital Copy attached, complies with Class A limits.



---

4) The product includes Local Area Network (LAN) options. When the Interface Cable is attached to either of the IEEE 802.3 connectors, the printer meets the requirements of EN 55022 Class A.



Boise, Idaho USA  
July 29, 1999



**For Compliance Information ONLY, contact:**

Australia Contact: Product Regulations Manager, Hewlett-Packard Australia Ltd., 31-41 Joseph Street, Blackburn, Victoria 3130, Australia



European Contact: Your local [HP Customer Care](#) center or Hewlett-Packard GmbH, Department HQ-TRE, Herrenberger Straße 130, D-71034 Böblingen (Germany) (FAX: +49-7031-14-3143)

USA Contact: Product Regulations Manager, Hewlett-Packard Company, PO Box 15, Mail Stop 160, Boise, ID 83707-0015 (Phone: 208-396-6000)



## Safety Statements



### Laser Safety Statement

The Center for Devices and Radiological Health (CDRH) of the U.S. Food and Drug Administration has implemented regulations for laser products manufactured since August 1, 1976. Compliance is mandatory for products marketed in the United States. The printer is certified as a “Class 1” laser product under the U.S. Department of Health and Human Services (DHHS) Radiation Performance Standard according to the Radiation Control for Health and Safety Act of 1968. Since radiation emitted inside the printer is completely confined within protective housings and external covers, the laser beam cannot escape during any phase of normal user operation.



**WARNING!** Using controls, making adjustments, or performing procedures other than those specified in this user’s guide may result in exposure to hazardous radiation.



## Canadian DOC Regulations

### ***HP LaserJet 8150, 8150 N, 8150 DN, 8150 HN***

Complies with Canadian EMC Class B requirements.

<<Conforme à la classe B des normes canadiennes de compatibilité électromagnétiques. << CEM>>.>>

### ***HP LaserJet 8150 MFP and all HP LaserJet 8150 printers with an HP Digital Copy attached***

Complies with Canadian EMC Class A requirements.

<<Conforme à la classe A des normes canadiennes de compatibilité électromagnétiques. << CEM>>.>>



## VCCI Statement (Japan)



HP LaserJet 8150, 8150 N, 8150 DN, 8150 HN

この装置は、情報処理装置等電波障害自主規制協議会（VCCI）の基準に基づくクラスB情報技術装置です。この装置は、家庭環境で使用することを目的としていますが、この装置がラジオやテレビジョン受信機に近接して使用されると、受信障害を引き起こすことがあります。取り扱い説明書に従って正しい取り扱いをして下さい。



HP LaserJet 8150 MFP and all HP LaserJet 8150 printers with an HP Digital Copy attached

この装置は、情報処理装置等電波障害自主規制協議会（VCCI）の基準に基づくクラスA情報技術装置です。この装置を家庭環境で使用すると電波妨害を引き起こすことがあります。この場合には使用者が適切な対策を講ずるよう要求されることがあります。



## Korean EMI statement



HP LaserJet 8150, 8150 N, 8150 DN, 8150 HN

사용자 안내문 (B급 기기)

이 기기는 비업무용으로 전자파장해 검정을 받은 기기로서, 주거지역에서는 물론 모든지역에서 사용할 수 있습니다.



HP LaserJet 8150 MFP and all HP LaserJet 8150 printers with an HP Digital Copy attached

사용자 안내문 (A급 기기)

이 기기는 업무용으로 전자파장해 검정을 받은 기기 이오니, 만약 잘못 구입하셨 을 때에는구입한 곳에 세 비업무용으로 교환하시기 바랍니다.



## *Laser Statement for Finland*

### **LASERTURVALLISUUS**

### **LUOKAN 1 LASERLAITE**

### **KLASS 1 LASER APPARAT**

HP LaserJet 8150, 8150 N, 8150 DN, 8150 HN, 8150 MFP -laserkirjoitin on käyttäjän kannalta turvallinen luokan 1 laserlaite. Normaalisessa käytössä kirjoittimen suojakotelointi estää lasersäteiden pääsyn laitteen ulkopuolelle.

Laitteen turvallisuusluokka on määritetty standardin EN 60825-1 (1994) mukaisesti.

### **VAROITUS !**

Laitteen käyttäminen muulla kuin käyttöohjeessa mainitulla tavalla saattaa altistaa käyttäjän turvallisuusluokan 1 ylittävälle näkymättömälle lasersäteilylle.

### **WARNING !**

Om apparaten används på annat sätt än i bruksanvisning specificerats, kan användaren utsättas för osynlig laserstrålning, som överskrider gränsen för laserklass 1.





## HUOLTO

HP LaserJet 8150, 8150 N, 8150 DN, 8150 HN, 8150 MFP-kirjoittimen sisällä ei ole käyttäjän huollettavissa olevia kohteita. Laitteen saa avata ja huoltaa ainoastaan sen huoltamiseen koulutettu henkilö. Tällaiseksi huoltotoimenpiteeksi ei katsota väriainekasetin vaihtamista, paperiradan puhdistusta tai muita käyttäjän käsikirjassa lueteltuja, käyttäjän tehtäväksi tarkoitettuja ylläpitotoimia, jotka voidaan suorittaa ilman erikoistyökaluja.

## **VARO !**

Mikäli kirjoittimen suojakotelo avataan, olet alttiina näkymättömälle lasersäteilylle laitteen ollessa toiminnassa. Älä katso säteeseen.

## **WARNING !**

Om laserprinterns skyddshölje öppnas då apparaten är i funktion, utsätts användaren för osynlig laserstrålning. Betrakta ej strålen.

Tiedot laitteessa käytettävän laserdiodin säteilyominaisuuksista:

Aallonpituus 765-795 nm

Teho 5 mW

Luokan 3B laser



# Index



## Numerics

[2000-sheet input tray, loading](#) 98

[5-bin mailbox with stapler](#) 284

[mode](#) 106

[paper jams](#) 219

[problem solving](#) 284

[7-bin tabletop mailbox](#)

[mode](#) 106

[paper jams](#) 219

[problem solving](#) 290

[8-bin mailbox](#)

[mode](#) 106

[paper jams](#) 219

[problem solving](#) 288

## A

[accessories](#)

[hard disk](#) 40

[installing hard disk](#) 479

[options](#) 37

[ordering](#) 42

[acoustic emissions](#) 419

[AutoCAD printer driver](#) 70

[automatic document feeder](#) 364

[loading](#) 364

[AUX connector](#) 369

## B

[bin](#)

[face-up](#) 105

[mailbox](#) 106

[standard](#) 103

[button functions](#)

[HP Digital Copy](#) 359

## C

[cable configuration](#) 292

[card stock](#) 410

[cleaning page](#) 199

[cleaning the printer](#) 197

[collation \(mopying\)](#) 146

[configuration](#)

[description of printer](#) 32

[configuration menu](#) 445

[configuration of MBM menu](#) 456

[configuration page](#)

[checking](#) 313  
[printing](#) 314  
[connectivity](#) 30  
[context sensitive help](#)  
[HP Digital Copy](#) 357  
[control panel](#)  
[HP Digital Copy](#) 347  
[keys](#) 56  
[layout](#) 53  
[lights](#) 54  
[messages](#) 226  
[printing a menu map](#) 59, 317  
[control panel menus](#)  
[about](#) 58  
[configuration menu](#) 445  
[configuration of MBM](#) 456  
[duplex registration menu](#) 464  
[EIO menu](#) 460  
[I/O menu](#) 457  
[information menu](#) 424  
[paper handling menu](#) 427  
[print quality menu](#) 435  
[printing a menu map](#) 59  
[printing menu](#) 439  
[private/stored jobs menu](#) 423  
[resets menu](#) 465  
[control panel overlay](#)

[installing](#) 342  
[copy connect cable](#)  
[installing](#) 339  
[copy connect EIO board](#)  
[installing](#) 338  
[customer support](#) 3  
[custom-sized paper](#)  
[loading](#) 163  
[setting](#) 143

## D

[Declaration of Conformity](#) 504  
[default configurations](#)  
[HP Digital Copy](#) 358  
[default setting, restoring](#) 465  
[dimensions of printer](#) 412  
[DIMMs](#)  
[about](#) 27  
[installing](#) 471  
[verifying](#) 475  
[directory page](#) 320  
[document quality](#)  
[HP Digital Copy](#) 371  
[downloadable firmware](#) 31  
[dual in-line memory module](#)  
[See DIMMs](#)  
[duplex registration](#) 187



[duplex registration menu 464](#)

[duplexer](#)

[paper jams 213](#)

[problem solving 293](#)

[duplexing 117](#)

[duty cycle 26](#)

## E

[EIO](#)

[installing 479](#)

[slots 30](#)

[EIO Menu 460](#)

[EMI statement \(Korea\) 511](#)

[envelope feeder](#)

[clearing paper jams 211](#)

[problem solving 295](#)

[size setting 427](#)

[type setting 428](#)

[envelope specifications 406](#)

[envelopes](#)

[wrinkles 260](#)

[environmental product stewardship 497](#)

[environmental specifications 417](#)

[equipment error](#)

[HP Digital Copy 379](#)

[error messages 226](#)

[escape sequences](#)

[combining 484](#)

[event log 321](#)

## F

[face-up bin 105](#)

[Fast InfraRed Connect 179](#)

[FCC statement 495](#)

[file directory page 320](#)

[Finland laser statement 512](#)

[5-bin mailbox with stapler 284](#)

[flatbed 366](#)

[loading 366](#)

[fonts](#)

[number included with printer 28](#)

[printing list 318](#)

[Foreign Interface Harness 369](#)

[fusing mode, variable 160](#)

## H

[hard disk 40](#)

[installing 479](#)

[problem solving 296](#)

[heavy paper 410](#)

[help](#)

[printer driver 77](#)

[using online 227](#)

[HP Digital Copy](#)





[automatic document feeder](#) 364  
[button functions](#) 359  
[context sensitive help](#) 357  
[control panel](#) 347  
[default configurations](#) 358  
[document quality](#) 371  
[equipment error](#) 379  
[flatbed](#) 366  
[installation specifications](#) 330  
[installing](#) 325  
[LED functions](#) 359  
[location requirements](#) 329  
[maintenance](#) 373  
[menu tabs](#) 349  
[operating instructions](#) 346  
[paper specifications](#) 370  
[parts](#) 326  
[problem solving](#) 377  
[settings](#) 362  
[status bar](#) 348  
[temporary error](#) 378  
[troubleshooting](#) 345  
[HP Fast InfraRed Connect](#)  
[about](#) 179  
[problem solving](#) 302  
[HP LaserJet Resource Manager](#) 86  
[HP support services](#) 3

[HP TonerGauge](#) 193  
[HP Web JetAdmin](#) 83  
[humidity, operating environment](#) 419

## I

[I/O buffering](#) 478  
[I/O menu](#) 457  
[information menu](#) 424  
[infrared](#)  
[printing with](#) 179  
[problem solving](#) 302  
[installing software](#)  
[Windows 3.1x](#) 73  
[Windows 9x, NT 4.0, and Windows 2000](#) 72

## J

[jam recovery](#) 453  
[JetDirect EIO](#) 310  
[JetSend, installing](#) 78  
[job accounting](#) 369  
[Job Retention](#) 166

## L

[labels, specifications](#) 403  
[laser statement for Finland](#) 512  
[LaserJet Resource Manager](#) 86  
[LED functions](#)



[HP Digital Copy](#) 359  
[LEDs, status interpretation](#) 60  
[letterhead paper, loading](#) 134  
[loading](#)  
   [automatic document feeder](#) 364  
   [flatbed](#) 366

## M

### Macintosh

[Job Retention](#) 166  
   [LaserJet Utility](#) 81, 85  
   [LaserWriter 8 driver](#) 80  
   [PPDs](#) 80, 308  
   [printer driver](#) 66  
   [problem solving](#) 305  
   [software](#) 74, 80

### mailbox

[operating modes](#) 106

### maintenance

[cleaning page](#) 199  
   [cleaning the printer](#) 197  
   [HP Digital Copy](#) 373  
   [kit, ordering](#) 50

### manual feed

 156

### mass storage

[installing](#) 479

### material safety data sheet

 502

### media

### See [paper](#)

### memory

[about](#) 27  
   [adjusting settings](#) 476  
   [allocated to languages](#) 476  
   [determining requirements](#) 470  
   [expandable](#) 419  
   [I/O buffering](#) 478  
   [installing](#) 471  
   [resource saving](#) 476  
   [verifying installation](#) 475

### Memory Enhancement technology (MEt)

 27

[menu map, printing](#) 59, 317

### menu tabs

[HP Digital Copy](#) 349

[messages](#) 226

### mopying

  See *a/so* [printer collation](#) 146

[multiple pages on one sheet](#) 152

## N

[network problem solving](#) 300

### network software

[about](#) 83

[Web JetAdmin](#) 63

[n-up printing](#) 152



## O

[online help, using](#) 227  
[operating instructions](#)  
     [HP Digital Copy](#) 346  
[options](#) 37  
[OS/2 printer drivers](#) 70  
[output bin](#)  
     [selecting](#) 101

## P

[paper](#)  
     [blank back page](#) 151  
     [custom or heavy stock](#) 143  
     [different first page](#) 149  
     [letterhead or preprinted, loading](#) 134  
     [loading](#)  
         [tray 1](#) 89  
         [tray 2 and 3](#) 93  
         [tray 4 \(2000-sheet\)](#) 98  
         [tray 4 and 5 \(2x500-sheet\)](#) 93  
     [multiple pages on one sheet](#) 152  
     [output](#)  
         [face-up bin](#) 105  
         [options](#) 106  
         [standard bin](#) 103  
     [prepunched](#) 134  
     [printing special](#) 134

[selecting by size and type](#) 157  
     [selecting output location](#) 101  
     [source](#) 89  
     [weight equivalence table](#) 400  
     See *a/so* [Tray](#)  
[paper handling](#)  
     [menu](#) 427  
     [options](#) 28  
[paper jams](#)  
     [5-bin mailbox with stapler](#) 219  
     [7-bin tabletop mailbox](#) 219  
     [8-bin mailbox](#) 219  
     [clearing](#) 202  
     [duplexer](#) 213  
     [envelope feeder](#) 211  
     [fuser area or left door](#) 218  
     [output areas](#) 217  
     [repeated](#) 224  
     [right door](#) 205  
     [top cover area](#) 215  
     [tray 1](#) 204  
     [tray 2 and 3](#) 206  
     [tray 4](#) 209  
     [tray 4 and 5 \(2x500-sheet\)](#) 207  
[paper specifications](#) 390– 411  
     [card stock or heavy paper](#) 410  
     [envelopes](#) 406



[HP Digital Copy](#) 370  
[labels](#) 403  
[transparencies](#) 405  
[parts and locations](#) 35  
[PCL fonts, selecting](#) 485  
[PCL printer commands](#) 486  
[PostScript Level 3 emulation](#)  
[See PS](#)  
[power](#)  
[consumption](#) 417  
[PowerSave mode](#) 417  
[requirements](#) 418  
[PPDs, Macintosh](#) 308  
[preprinted paper, loading](#) 134  
[prepunched paper, loading](#) 134  
[preventive maintenance kit](#) 190  
[ordering](#) 50  
[print quality menu](#) 435  
[print quality problem solving](#) 254  
[print servers](#) 30  
[printer](#)  
[configuration](#) 32  
[features](#) 26  
[parts location](#) 35  
[specifications](#) 412  
[printer collation \(mopying\)](#) 146  
[printer driver](#)

[about](#) 66  
[accessing windows drivers](#) 75  
[AutoCAD](#) 70  
[blank back page](#) 151  
[choosing](#) 77  
[different first page](#) 149  
[features](#) 146  
[help](#) 77  
[included](#) 67  
[Macintosh](#) 66  
[Macintosh PPDs](#) 308  
[multiple pages on one sheet](#) 152  
[obtaining most recent](#) 70  
[OS/2 and WordPerfect 5.1](#) 70  
[PPDs](#) 67  
[RIP ONCE](#) 147  
[saving setup information](#) 147  
[selecting paper by size and type](#) 157  
[watermark](#) 148  
[printer language](#)  
[about](#) 28  
[allocating memory](#) 476  
[Printer Maintenance Kit](#) 190  
[printing menu](#) 439  
[private/stored jobs menu](#) 423  
[problem solving](#)  
[about](#) 200







[checklist](#) 262  
[common problems](#) 267  
[HP Digital Copy](#) 377  
[HP Fast InfraRed Connect](#) 302  
[Macintosh](#) 305  
[network and I/O port](#) 300  
[paper jam locations](#) 203  
[paper jams](#) 202  
[print quality](#) 254  
[PS errors](#) 298  
[repeating paper jams](#) 224  
[Proof and Hold jobs](#) 170  
[PS](#) 67

## Q

[quick copy](#) 167

## R

[resets menu](#) 465  
[Resolution Enhancement technology \(REt\)](#) 26  
[Resource Manager, HP LaserJet](#) 86  
[RIP ONCE](#)  
[about](#) 147  
[hard disk](#) 48

## S

[service and support information](#) 380  
[settings](#)

[HP Digital Copy](#) 362  
[7-bin tabletop mailbox](#)  
[problem solving](#) 290  
[size of printer](#) 412  
[software](#)  
[about](#) 62  
[Apple LaserWriter 8 driver](#) 80  
[JetSend](#) 78  
[LaserJet Resource Manager](#) 86  
[LaserJet Utility](#) 81, 85  
[Macintosh](#) 74, 80  
[network](#) 83  
[obtaining most recent](#) 70  
[PPDs](#) 67  
[typical or custom install](#) 71  
[Web JetAdmin](#) 83  
[Windows 3.1x](#) 73  
[Windows 9x, NT 4.0, and Windows 2000](#) 72  
[speed, printing](#) 419  
[stapler, clearing jams](#) 222  
[status bar](#)  
[HP Digital Copy](#) 348  
[storing jobs](#) 176  
[supplies, ordering](#) 42  
[support services](#) 3

## T

[temperature, operating environment](#) 419

[temporary error](#)[HP Digital Copy 378](#)[toner cartridge](#)[checking toner level 192](#)[life expectancy 192](#)[limited warranty 385](#)[managing 191](#)[printing with low toner 194](#)[resetting HP TonerGauge 193](#)[storage 191](#)[TonerGauge 193](#)[transparency, specifications 405](#)[Tray 1](#)[clearing paper jams 204](#)[customizing \(modes\) 154](#)[loading 89](#)[manual feed 156](#)[problem solving 280](#)[Tray 2 and 3](#)[loading 93](#)[paper jam 206](#)[problem solving 280](#)[Tray 4 \(2000-sheet\)](#)[loading 98](#)[paper jams 209](#)[problem solving 281](#)[Tray 4 and 5 \(2x500-sheet\)](#)[loading 93](#)[paper jams 207](#)[problem solving 280](#)[troubleshooting](#)[HP Digital Copy 345](#)[See problem solving](#)[2000-sheet input tray, loading 98](#)[two-sided printing 117](#)**V**[variable fusing mode 160](#)[VCCI statement \(Japan\) 510](#)**W**[warranty statement 381](#)[watermark 148](#)[Web JetAdmin 83](#)[installing 63](#)[web servers, supported 83](#)[weight of printer 416](#)[Windows](#)[Job Retention 166](#)[Windows 3.1x, installing software 73](#)[Windows 9x, NT 4.0, and Windows 2000,](#)[installing software 72](#)[WordPerfect 5.1 printer driver 70](#)[World Wide Web support 3](#)

[wrinkled envelopes 260](#)

**Y**

[Y power cord  
installing 341](#)

