

C4704A/C4703A

# HP DesignJet 2500/2000CP Printer



**User's Guide**

Printed in Europe

All rights are reserved. No part of this document may be photocopied, reproduced, or translated to another language without the prior written consent of Hewlett-Packard Company.

3M™ is a registered trademark of 3M Company.

Adobe™ is a trademark of Adobe Systems Incorporated which may be registered in certain jurisdictions.

Adobe PageMaker™ and Adobe Photoshop™ are trademarks of Adobe Systems Incorporated which may be registered in certain jurisdictions.

IEEE-1284 compatible, HP-GL, and HP-GL/2 are trademarks of Hewlett-Packard Company.

Macintosh is a product of Apple Computer Inc.

Microsoft® and MS-DOS® are registered trademarks of Microsoft Corporation.

Microsoft Windows is a registered trademark of Microsoft Corporation

PANTONE® and PANTONE MATCHING SYSTEM® are licensed trademarks of Pantone, Inc. PANTONE®<sup>1</sup> Colors generated by the HP DesignJet 2000CP/2500CP printers are four-color process simulations and may not match PANTONE-identified solid color standards. Use current PANTONE Color Reference Manuals for accurate color. PANTONE Color simulations are only obtainable on this product when driven by qualified Pantone-licensed software packages. Contact Pantone, Inc. for a current list of qualified licensees.

1. Pantone, Inc.'s check-standard trademark for color. ©Pantone, Inc. 1988

PostScript® is a registered trademark of Adobe Systems Incorporated.

QuickDraw™ is a trademark of Apple Computer Inc.

UNIX® is a registered trademark in the United States and other countries, licensed exclusively through X/Open Company Limited.

"WingDings™ in TrueType® format is a product of Microsoft Corporation. WingDings is a trademark of Microsoft Corporation and TrueType® is a registered trademark of Apple Computer, Inc."

#### Notice

The information contained in this document is subject to change without notice and should not be construed as a commitment by Hewlett-Packard Company.

**Hewlett-Packard assumes no responsibility for any errors that may appear in this document nor does it make expressed or implied warranty of any kind with regard to this material, including, but not limited to the implied warranties of merchantability and fitness for a particular purpose.**

The Hewlett-Packard Company shall not be liable for incidental or consequential damages in connection with, or arising out of the furnishing, performance, or use of this document and the program material which it describes.

#### Safety Symbols



The product is marked with this symbol when it is necessary for you to refer the instruction manual in order to protect against damage to the product.



Hazardous voltage symbol.

#### WARNING

The Warning symbol calls attention to a procedure, practice, or the like, which, if not correctly performed or adhered to, could result in personal injury. Do not proceed beyond a Warning symbol until the indicated conditions are fully understood and met.

#### HP DesignJet Printers - Year 2000 Compliance



All HP DesignJet printer products including all the HP software, hardware, firmware and accessories for the HP DesignJet printers are Year 2000 Compliant. HP DesignJet printers will function with all the reliability and quality associated with Hewlett-Packard as the transition is made into the 21st century.

“Year 2000 Compliant Products” are products able to accurately process date data (including, but not limited to, calculating, comparing and sequencing dates, from, into and between the twentieth and twenty-first centuries, including leap year calculations, when used in accordance with its product documentation, and provided all other products used in combination with the product properly exchange data with it.

HP has made every effort to ensure the accuracy of out product testing. However, because each customer's environment is different from HP's laboratory test environment, it is the customer's responsibility to validate the Year 2000 readiness of these products in their own environment. Therefore, information about the Year 2000 status of HP products is provided “as is” without warranties of any kind.

HP makes no representation or warranty respecting the accuracy or reliability of information about non-HP products. Such information, if any, was provided by the manufacturers of those products and customers are urged to contact the manufacturer directly to verify Year 2000 readiness.

For further information on how HP is preparing for the approaching millennium visit the HP Year 2000 Program web site:  
<http://www.hp.com/year2000/>

C4704-90241 English

# **User's Guide**

## **HP DesignJet 2500CP/ 2000CP Printer**

## Finding Information

### **This User's Guide contains:**

- A comprehensive explanation of all the printer's features and specific information directly associated with the HP DesignJet CP Ink System (Imaging ink)
- Specific information directly associated with the HP DesignJet CP Ink System UV (UV Pigmented ink)
- Information on using the Take Up Reel.

### **The Assembly Instructions contain:**

Step by step instructions for unpacking the printer and installing the Legs.

### **The Take Up Reel Setup and Assembly Instructions contain**

Step by step instructions for installing and setting up the Take Up Reel.

### **The Setup Guide contains:**

- Detailed information on setting up your printer for the first time, including:
  - initial installation of the ink system components
  - loading media
  - connecting your printer to a computer or network
  - setting up your printer software

### **The Quick Reference Guide contains:**

- Information that you are most likely to need at the printer on a day-by-day basis, such as how to navigate through the front-panel menu, load media, and replace ink systems.



### **CD-Rom**

When this symbol is displayed it indicates that there is video footage available which gives you more information on the subject. Refer to the CD "Installing and using HP DesignJet Printers" or "A User's Introduction" which is only in English.

## Where to find the most commonly needed information

To find how to ...	Go to ...
Install the printer	←The Setup Guide.
Connect the printer	←The Setup Guide.
Choose media	←Page 3-2, <i>Choosing Media</i> in this guide.
Load media	←Page 3-13, <i>Loading Roll Media</i> in this guide or the quick reference guide.
Load the Take Up Reel	←Page 3-19, <i>Loading Media onto the Take Up Reel accessory</i>
Replace ink system components	←Page 4-11, <i>Removing and Replacing Ink Systems</i> in this guide.
See the printer's current configuration	←Page 8-5, <i>Viewing the Current Configuration of the Front-Panel Settings</i> .
Turning on the Take up Reel	←Page 8-12, <i>Turning on the Take Up Reel</i>
Make selections in the front-panel menu	←Page 2-14, <i>Navigating the Menu System</i> .
Clear a media jam	←Page 11-44, <i>Clearing a Media Jam</i>
Solve image quality problems	←Page 11-5, <i>Solving Image-Quality Problems</i>
How to Solve Ink System Problems	←Page 11-31, <i>Solving Ink System Problems</i>
Interpret a front-panel message	←Chapter 12, <i>Front-Panel Messages</i> .
Order accessories	←Page 13-18, <i>Ordering Accessories</i>
<b>To find any other information</b>	Go to the index at the back of this manual.

# Table of Contents

## **Welcome 1-1**

A Five-Minute Guide To Your Printer 1-2

Your Printer's Main Features 1-2

Connections 1-7

Memory 1-7

Software Applications and Drivers 1-8

Front View of Printer 1-9

Rear View of printer 1-10

## **Using the Front Panel 2-1**

The Front Panel 2-2

Standby Mode 2-6

Printing the Current Configuration 2-7

Entering the Menu System 2-8

Printing the Menus 2-9

Printing Other Internal Prints 2-12

Navigating the Menu System 2-14

Menu Graphics Used in This Manual 2-15

Navigation Examples 2-16

Selecting the Full Menu Mode 2-16

Changing the Color Calibration Setting in the Image Quality Menu 2-18

Changing the Merge Setting in HP-GL/2 Settings 2-21

Changing Margins 2-24

Changing the Drying Time 2-26

Other Types of Front-Panel Display Information 2-28

## **Working with Media 3-1**

Choosing Media 3-2

Some Important Points about Media Types 3-3

Supported Media Types 3-4

Using the Ink System UV Outside 3-5

Laminating the Media after Printing 3-5

Applying the Overlaminates to a Finished Print 3-5

Installing the Final Print 3-6

Media Types 3-8

HP Commercial Names of Media Types 3-8

- Physical Characteristics of Media Types 3-9
- Combinations of Media Type and Print Quality 3-10
- Using Coated Paper and Heavy Coated Paper with Normal Mode 3-11
- Handling Your Media 3-12
- Loading Roll Media 3-13
- Loading Media onto the Take Up Reel accessory 3-19
- Unloading Media from the Take Up Reel accessory 3-26
- Removing a Roll from the Printer 3-30
- Installing a New Roll into the Printer 3-32
- Changing the Core Tube on the Take Up Reel 3-35
- Loading sheet media 3-39
- Unloading Sheet Media 3-42
  - Compensating for Badly Cut Media 3-27
  - Adjusting Skew Tolerance 3-27
- Drying time (With a Take Up Reel) 3-44
- Drying Time (Without a Take Up Reel) 3-46

## **Working with Ink Systems 4-1**

- About the Ink System 4-2
  - The HP DesignJet CP Ink Systems 4-2
  - Main Features of the HP DesignJet CP Ink System 4-2
  - What is an Ink System? 4-3
  - How to Identify the HP DesignJet CP Ink System UV Components 4-4
  - Identifying the Ink System in the Printer 4-4
  - When Does the Ink System Refill the Printheads? 4-5
- Obtaining Optimum Refill Performance using non-HP media. 4-6
  - Refilling the Printheads from the Front Panel 4-8
  - How big a print can I make without a refill? 4-8
- Monitoring the Ink Level 4-9
  - When should I Replace an Ink System? 4-10
- Removing and Replacing Ink Systems 4-11
  - Working with multiple Ink Systems 4-12
  - Handle Ink Systems with Care 4-12
- Replace the Ink System 4-13
- After replacing the Ink System 4-23
- Removing and Storing Partially Used Ink Systems 4-24
  - Handle the Ink Systems with Care 4-24
  - Storing the Ink System in the HP DesignJet CP Ink System Storage Container 4-25
  - Removing the Ink System from the HP DesignJet CP Ink System Storage Container 4-29

## **Controlling the Page Format 5-1**

### Page Format 5-2

Do You Need to Adjust the Page Size in the Front Panel? 5-4

Adjusting the Page Size in the Front Panel 5-5

Page Size and Clipped Images 5-7

Page Size and Nesting (Roll Media Only) 5-7

### Page Size and Accuracy 5-8

Page Size Using the HP DesignJet CP UV Ink System 5-10

### Selecting the Ink Emulation Mode 5-11

### Adjusting Margins for Roll and Sheet Media 5-12

Margins and Automatic Cutting 5-14

Print Margins using the HP DesignJet CP UV Ink System 5-14

### Rotating an Image 5-15

Rotating an Image from the Front Panel 5-15

What is Rotated? 5-16

How Does Rotate Interact with Your Software? 5-17

### Printing a Mirror Image 5-19

### Changing the Scale of a Printed Image 5-20

## **Controlling the Overall appearance of a Print 6-1**

### Ways of Controlling the Print's Appearance 6-2

### Changing Pen Widths and Colors Using the Internal Palettes 6-3

To Select a Palette 6-4

Viewing Current Config. Settings 6-5

Viewing the Colors Available For a Palette 6-6

To Change the Palette Settings 6-7

### Changing the Treatment of Overlapping Lines

(Merge) 6-9

### Printing Color Images in Monochrome 6-10

Switching between Color and Monochrome 6-11

### Printing Speeds and Print Quality 6-12

Print quality settings 6-14

Changing the print quality 6-16

## **Managing Your Prints 7-1**

### Managing Pages Currently being Printed or Drying 7-2

Cancelling a Page 7-2

Cutting a Page before Drying is Complete

(Roll Media Only) 7-3



- Pausing while Printing a Series of Pages 7-4
- Managing Pages not yet Printed (the Queue) 7-5
  - What is the Queue? 7-5
  - Starting to Print a File that is Waiting for a Time-out 7-7
  - Identifying a Job in the Queue 7-8
  - Viewing the Size of a Page in the Queue (Non-Postscript) 7-8
  - Prioritizing a Job in the Queue 7-9
  - Deleting a Job from the Queue 7-9
  - Making Copies of a Job in the Queue 7-10
- Avoiding Media Waste by Nesting Pages 7-11
  - When Does the Printer Try to Nest Pages? 7-13
  - Which Pages Qualify for Nesting? 7-13
  - Which Pages Cannot be Rotated? 7-13
  - Turning Nesting On or Off and Choosing the Nesting Method 7-14
  - What Happens to Nesting if You Turn Queueing Off? 7-14
  - How Long does the Printer Wait for Another File? 7-15
  - Getting the Best from Nesting (Nesting and Margins) 7-16
  - Nesting and the Rotate Feature 7-16

## **Reconfiguring Your Printer 8-1**

- Viewing the Current Overall Configuration of the Printer 8-2
- Viewing the Current Configuration of the Front-Panel Settings 8-5
- To Change the Front-Panel Settings 8-5
- Recalibrating the Printer for Accuracy 8-6
  - When to Recalibrate the Printer 8-6
  - To Recalibrate the Printer 8-6
  - To Restore the Factory's Calibration 8-7
- Changing the Graphics Language 8-8
  - To Change the Graphics Language Setting 8-8
  - Graphics Language and Networks 8-9
- Changing the Interface Settings 8-10
  - To Change the I/O Time-out Setting 8-10
- Upgrading Your Printer with More Memory 8-11
- Turning on the Take Up Reel 8-12

## **Controlling Image Quality 9-1**

- Selecting the Ink Emulation Mode 9-2
- Calibrating the Color Output 9-3

## Table of Contents

Comparing Color Output between Imaging and UV Ink Systems	9-3
Performing a Image Quality Test	9-4
Servicing the Printheads	9-5
Aligning Printheads	9-5
Refilling Printheads	9-5
Checking Printheads	9-6
Media Test Print	9-7
How to perform the Media Test Print	9-8
Changing the Print Quality when Media is Already Loaded	9-10

### **Maintaining Your Printer 10-1**

Cleaning the Printer	10-2
Cleaning the Printer Exterior and Inside the Doors	10-2
Lens Maintenance	10-3
Replacing the Lens Cover	10-4
Normal Printer Use	10-6
Storing and Moving Your Printer	10-7
Selecting Transport Mode	10-7
Removing the Printheads	10-8
Removing the Printhead Cleaners	10-9
Removing the Ink Cartridges	10-11
Switching off and Disconnecting the Printer	10-13

### **Troubleshooting 11-1**

A Note About Troubleshooting	11-2
Where to Find Help in Solving Problems	11-3
Finding the Source of Your Problem	11-4
Solving Image-Quality Problems	11-5
How to Proceed with the Image Quality Print Diagnosis	11-5
If the Color is Not as Expected	11-6
Some General Information About the Image Quality Test	11-7
Identifying the Printhead Components	11-7
How to Use the Image Quality Print	11-8
Printing the Image Quality Print	11-8
Analyzing the Image Quality Test Results	11-10
Solving the Problems	11-11
No Printing Defects Found in the Image Quality Print	11-22
Solving Color Accuracy problems	11-23
Color Consistency problems	11-23

- Configuration 11-24
- Media 11-24
  - Where to Find Additional Information 11-26
  - If There are Slightly Warped Lines 11-26
  - If There are Blurred Lines (Ink “Bleeds” from Lines) 11-26
  - If there is a horizontal line 2 inches (5.5 cms) from the start of your image. 11-26
  - There are Smears and/or Scratching on Your Printed Media. 11-27
- Solving Media-Handling Problems 11-28
  - The Front Panel Keeps Indicating that Media Is Misaligned or Incorrectly Positioned 11-28
  - Prints Do Not Feed Out Properly From the Printer 11-28
  - The Automatic Cutter does not Cut Immediately after a Print has Finished 11-28
  - The Automatic Cutter does not Work 11-29
  - The Cutter is Jammed 11-30
  - A Sheet is Ejected when You Switch On the Printer 11-30
- Solving Ink System Problems 11-31
  - Missing Ink System 11-31
  - Ink System Error 11-31
  - Summary of Ink System Defect Messages 11-32
  - If the Replace Ink System Key does not Work 11-34
  - If Brand New Printheads have Problems 11-34
  - If there is a Failure after Refilling Printheads 11-34
  - Printhead Alignment Errors 11-35
  - Printhead Checks 11-37
  - Using the Replace Ink System Key 11-37
  - Checking Ink Systems 11-38
  - If You Have Problems Reseating a Printhead 11-41
  - Cleaning Electrical Contacts 11-42
- Clearing a Media Jam 11-44
- Solving Communication Problems 11-45
  - If there is a Problem Communicating between Your Computer and the Printer 11-45
- Solving Problems with Image Position or Content 11-46
  - If the Print is Completely Blank 11-46
  - If the Output Contains Only a Partial Print 11-46
  - If the Image is Clipped 11-47
  - If a Long-Axis Print Is Clipped 11-47
  - If the Entire Image is in One Quadrant of the Correct Printing Area 11-48
  - If the Image Is Unexpectedly Rotated 11-48
  - If the Print Is a Mirror Image of Your Graphic 11-48

## Table of Contents

If the Print Is Inaccurate	11-48
If the Print is Distorted or Unintelligible	11-49
If One Image Overlays Another on the Same Sheet	11-49
If Pen Settings Seem to have No Effect	11-49
If the Printer Produces a Black and White Print When You Expected a Color Print	11-49
If the Printer has Printed a Different Print than the One You were Expecting	11-50
Solving Front-Panel Problems	11-51
If the Replace Ink System Key Does Not Work	11-51
If None of the Front-Panel Keys Work	11-51
If Page Format/Rotate does not Work	11-51
If a Display Message will not Clear	11-51
If a “System Error” Message Is Displayed	11-52
If an “Out Of Memory/Data Was Lost” Message Is Displayed	11-52
Problems with the Take Up Reel	11-53
Solving Miscellaneous Problems	11-54
If the Printer does not Print	11-54
If the Printer Seems Too Slow	11-54
If the Printer Waits Too Long to Print a Nest	11-55
If the Bail (Black Metal Bar) does not Lower All the Way	11-55
The Media coming from the Printer is Fed Back into the Printer causing a Media Jam.	11-55
Getting Help	11-56
What to Do Before You Call	11-56

## **Front-Panel Messages 12-1**

Message Explanations and Actions	12-2
STATUS Messages	12-17

## **Reference 13-1**

Printer Specifications	13-2
Interface Specifications	13-10
Interface Cables	13-11
Regulatory Notices	13-12

## **Glossary G-1**

## **Index I-1**

---

# Welcome

# *1*

---

A Five-Minute Guide To Your Printer 1-2

Front View of Printer 1-9

Rear View of printer 1-10

# A Five-Minute Guide To Your Printer

## Your Printer's Main Features

Your printer is an E/A0-size inkjet printer designed for printing high-quality, large-format color or monochrome images. Some major features of the printer are:

- Large capacity ink system
- True 600 dpi print resolution.
- A choice of HP media designed to provide the best image quality with your printer.
- An easy-to-use front-panel interface with a two-line display, giving you access to a comprehensive set of printer functions.
- Available as an optional accessory is the Take Up Reel. This enables long unattended prints

---

### 2500CP Only

- Built-in Adobe PostScript Level 3 Raster Image Processor.
- Automatic color calibration to improve color consistency between jobs.
- Ink emulation allowing the printer to print jobs intended for devices using standard pre-press color gamuts.
- PostScript queueing and nesting to reduce media waste.
- Large and very-complex PostScript file printing.

## The Take Up Reel Accessory

Available with your printer as an option is the Take Up Reel. The Take Up Reel consists of the left and right hand assemblies, sensor assembly, spindle assembly, core tube and a media weight. As the media is fed out of the printer (1) it travels down the front of the printer, around the Media Weight (2) and then onto the Core Tube (3). The Core Tube turns, reeling in the printed media.

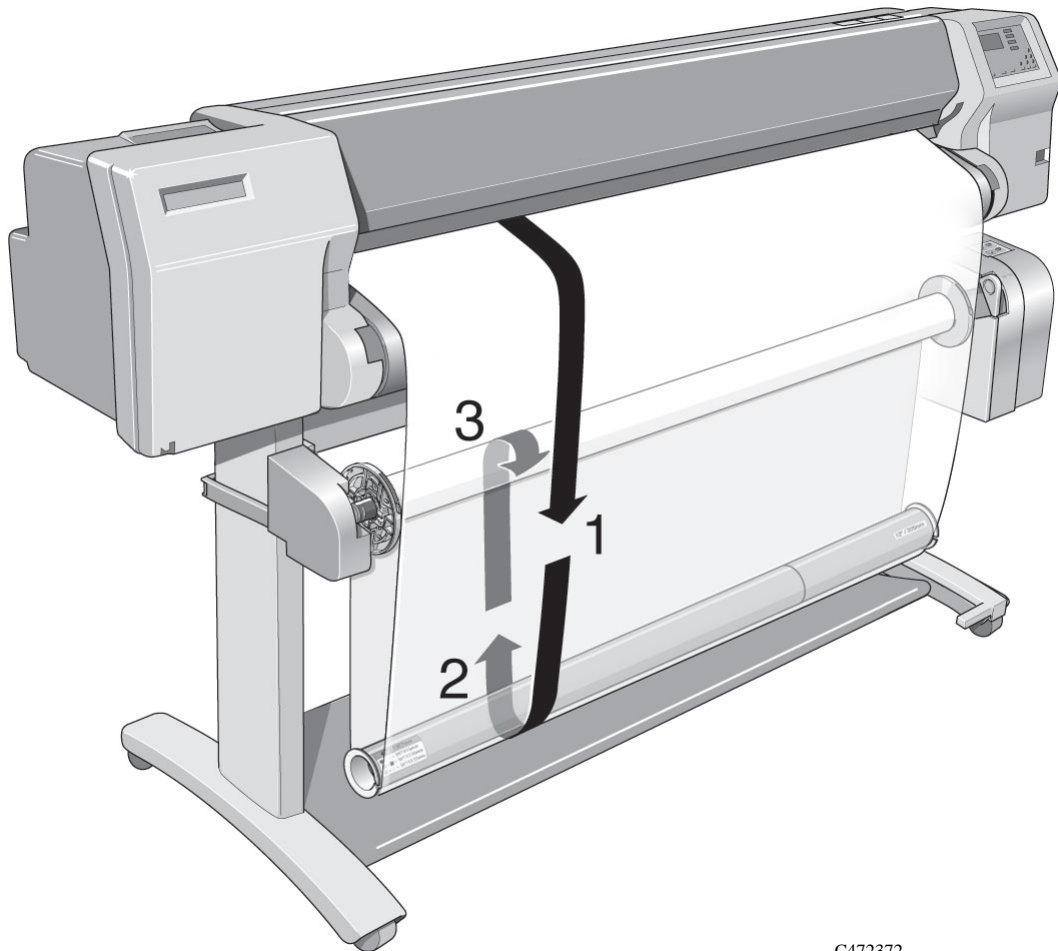

C472372

## The HP DesignJet CP Ink Systems

There are two HP DesignJet CP Ink Systems designed together with your HP DesignJet 2500CP or 2000CP printer.

Both Ink Systems include three-components; printhead, printhead cleaner and ink cartridge to provide large-capacity ink, unattended printing, ease-of-use, reliability and low-cost. Plus both Ink Systems offer true 600 dpi and new advanced dithering algorithms for exceptional image quality prints.

Each 600-dpi thermal inkjet printhead applies ink droplets onto the media and has a reservoir which holds enough ink for several prints. The printer automatically refills the printhead from the ink cartridge whenever the ink volume in the printhead reservoir becomes low.

The printer uses the printhead cleaners to clean and maintain the printheads, to ensure best possible image quality, and to seal the printheads when not in use ensuring the long life.

You can change Ink Systems as easy as 1—2—3 with the modular design. If you do change one ink set for another, HP offer an Ink System Storage Container to store partially used printheads and printhead cleaners.

### Main Features of the HP DesignJet CP Ink System

The HP DesignJet CP Ink System is the ink system that you received with your HP DesignJet CP printer. It is also referred to as **Imaging ink**. It is designed to deliver clear, sharp, brilliant images with precise performance every time.

### Main Features of the HP DesignJet CP Ink System UV

The HP DesignJet CP Ink UV can be purchased separately from your local Hewlett-Packard dealer. It is also referred to as **UV Pigmented ink**. The HP DesignJet CP Ink UV prints bright, colorful, outdoor lightfast signs and posters with a HP Outdoor Durability Warranty.

The HP DesignJet CP Ink UV is designed to work together with the HP DesignJet CP printers to create clear prints that are lightfast and durable with lamination, even outdoor in direct sunlight, for up to one year, guaranteed.

The UV Pigmented inks provide resistance to ultra violet light. Protecting your prints from fading and enhancing the durability of signs and posters.



### **Color Calibration (2500CP)**

Automatic color calibration improves color consistency between prints. The printer prints a test target image and measures the image color with a sensor to generate a color calibration value that is applied to the PostScript imaging process.

### **Ink emulation (2500CP)**

Ink emulation lets your printer accept CYMK PostScript files that use printing industry standard color gamuts, enabling the printer to emulate commercial printing presses for proofing.

### **PostScript queuing and nesting (2500CP)**

PostScript queuing enables files to be reprinted quickly. PostScript nesting reduces media waste by storing jobs and then positioning them to use the maximum width of the media roll, reducing your printing costs.

### **Large/Complex PostScript file printing (2500CP)**

The printer uses a built-in hard disk drive as extended memory for PostScript rendering, enabling the printer to process almost any PostScript file you want to print.

### **Multiple copies of prints (2500CP)**

The built-in hard disk drive allows enhanced print management, enabling the printer to print multiple copies of an image without re-rendering and nesting of prints.

### **Print Resolution**

Print resolution can be set to true 600 dots per inch (Best print quality) or 300 dots per inch (Normal or Fast print quality mode). You can choose between the three levels of print quality- Best, Normal or Fast - either from your software or from the printer's front panel.

## **Media**

You can print on roll media or sheet media up to EA0-size in width-91cm (36 inches).The following media types are supported for HP DesignJet CP Ink (imaging ink) which is high image quality for indoor use:

- Coated paper
- Heavyweight coated paper
- High-gloss photo paper
- Semi-gloss photo paper
- Imaging film-Backlit
- Opaque vinyl

For detailed information on Hewlett-Packard media, see pages 3-4 of this manual and the *Media Guide for the HP DesignJet CP Printers* provided with your printer.

The following media types are supported for HP DesignJet CP Ink UV (UVPigmented Ink)

- HP Heavyweight Coated paper
- Opaque Vinyl

## **User Interface**

The printer's front panel includes an easy-to-use interface with a two-line display, giving you access to a comprehensive set of printer functions and to a number of useful internal prints. See Chapter 2, *Using the Front Panel*, for a short tutorial to teach you how to navigate through the menus and a description of internal prints.

## **Standby Mode**

The printer has a standby mode where, after 15 minutes of inactivity, the printer goes into a sleep mode (low-power usage mode). The printer “wakes up” whenever you press the Standby button on the printer or there is any I/O activity such as receipt of a file. See page1-9, *Front View of Printer*, for the switch location and page 2-6, *Standby Mode*, for more information about this function.

## Connections

---

### 2500CP Only

The 2500CP printer comes with an HP JetDirect network interface card, for LAN connections, as well as a parallel interface for a direct connection to your computer. See the Setup Guide for information on connecting your printer to a computer or network.

---

### 2000CP Only

Your printer comes with a Modular IO (MIO) slot which can be used to connect a networking card.

## Memory

---

### 2500CP Only

The 2500CP printer comes with 32MB of memory plus 4 MB of internal printing memory. You can this expand memory up to a maximum of 68 MB by adding 4-MB, 8-MB, 16-MB or 32-MB memory SIMMS. In addition to this memory, the printer has an internal hard disk drive used as extended memory for PostScript rendering and print management.

For part numbers see page 13-19, *Memory Modules*

---

### 2000CP Only

Your printer comes with 4 MB of memory plus 4 MB of internal printing memory. You can expand the memory up to a maximum of 68 MB by adding additional 8-MB, 16-MB, and 32-MB memory expansion modules.

For part numbers see page 13-19, *Memory Modules*

## Software Applications and Drivers

To make sure that your printer prints exactly what you were expecting - in terms of size, position, orientation, color and quality - use the correct driver for the combination of your application software and your printer, and make sure that it is configured correctly.

Many software applications include their own drivers. A set of Software Application Notes is provided with this printer for the most popular applications. If you find your own application in these notes, use the information they contain as a guide to configuring the software for your printer.

Three types of drivers are supplied with the 2500CP printer:

- HP DesignJet PostScript® drivers for Macintosh® (QuickDraw™)
- HP DesignJet PostScript® drivers for Microsoft® Windows™ applications
- AutoCAD Drivers for DOS and Windows

Two types of drivers are supplied with the 2000CP printer:

- HP-GL/2 Windows Drivers
- AutoCAD Drivers for DOS and Windows

Some printer functions behave differently when the printer receives a PostScript file as opposed to files formatted in other printer languages (HP-GL/2 or RTL). Throughout this manual, references to “PostScript files” mean files sent to the printer using the HP DesignJet PostScript driver supplied with the printer and installed by you on your Macintosh or PC.

If you don't know whether your application sends PostScript files consult your software documentation.

It is strongly recommended that you install and use the AutoCAD drivers to print from AutoCAD. More CAD-orientated functionality is provided with these drivers, they are also faster than HP-GL/2 or PostScript windows drivers.

# Front View of Printer

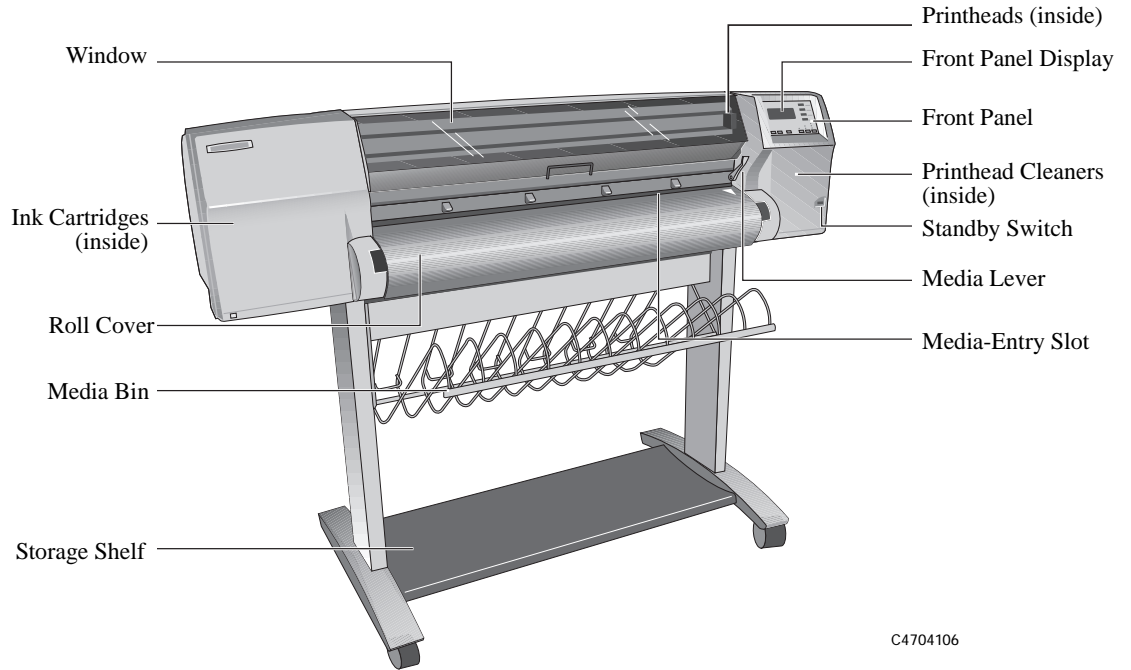

C4704106

## Rear View of printer

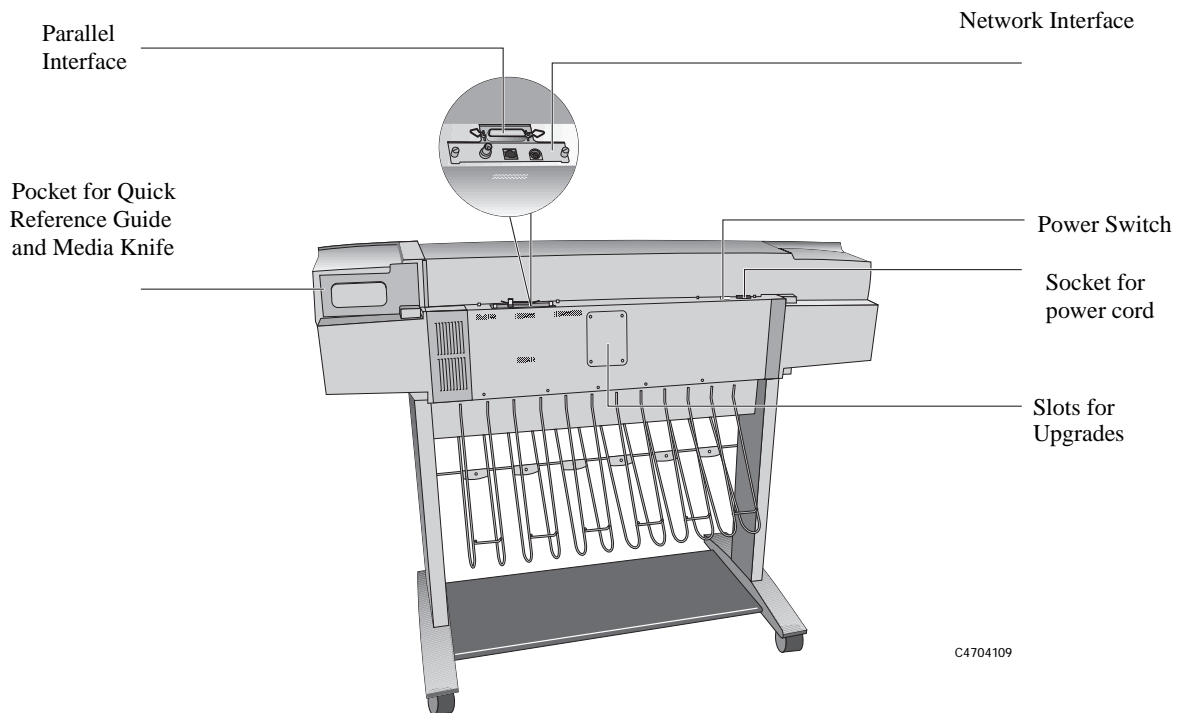

C4704109

---

# Using the Front Panel

# 2

---

The Front Panel	2-2
Standby Mode	2-6
Printing the Current Configuration	2-7
Entering the Menu System	2-8
Printing the Menus	2-9
Printing Other Internal Prints	2-12
Navigating the Menu System	2-14
Menu Graphics Used in This Manual	2-15
Navigation Examples	2-16
Other Types of Front-Panel Display Information	2-28

# The Front Panel

The front panel of the printer is made up of four functional areas as shown below:

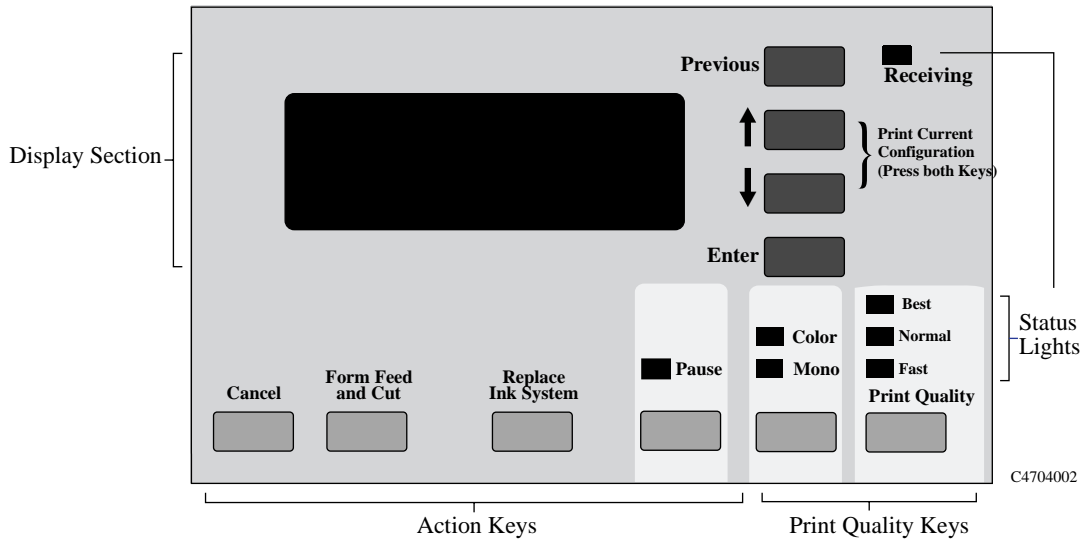



## Display Section



The display section of the front panel consists of the two-line display and the four display keys to its right (**Previous**, **↑**, **↓** and **Enter**).

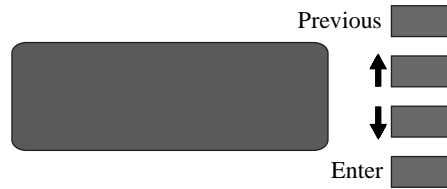

C4704016

- The display can show two lines of text and is used for displaying:
  - menus used to configure the printer.



C4704007

- and messages.

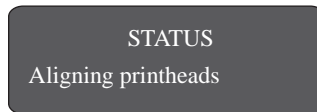

C4704034

- These messages may concern printer status, required actions or errors.
- You use the display keys to navigate the menu system and select menu options. You also use the display keys to respond to messages. see chapter 12, *Front-Panel Messages*, for detailed descriptions for error and status messages.

Later sections of this chapter give detailed instructions for using the display keys to navigate the menu system and select menu options, as well as other uses of the display keys.

## Using the Front Panel The Front Panel

### Action Keys

The action keys let you:

- cancel the current printer operation (**Cancel**).
- advance and cut media (**Form Feed and Cut**).
- replace ink system components (**Replace Ink System**).
- pause the printer (**Pause**).

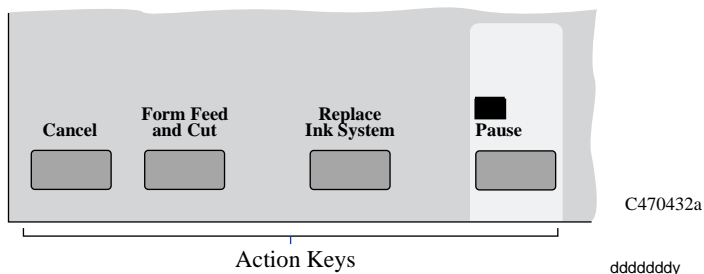

See chapter 7, *Managing Your Prints*, for information on the use of these keys.

### Print Quality Keys

Use the print quality keys to select whether to print in color or monochrome (black and grayscale) and to select the print quality you want. See chapter 6, *Controlling the Overall appearance of a Print*, for information on the use of these keys.

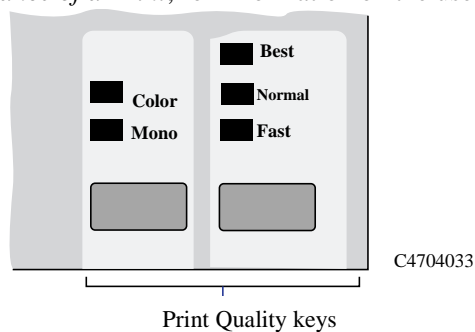

## Status Lights

The status lights provide status information about the current configuration and state of the printer. These lights are described later in this manual

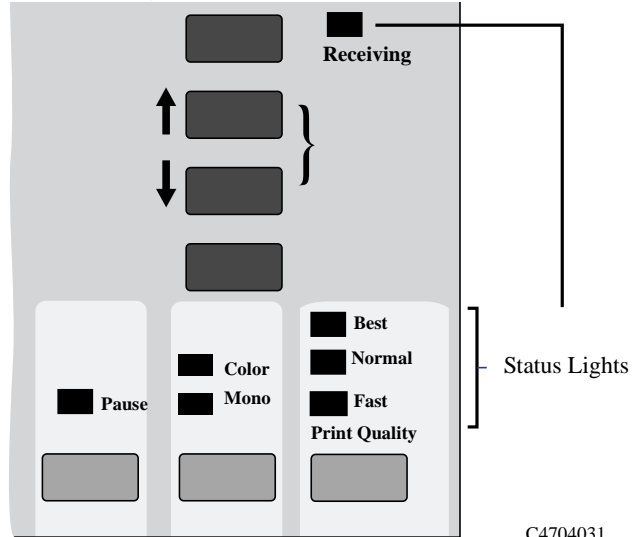

C4704031

---

### NOTE

---

**In most cases, settings in your application software or printer driver override any settings you make on the front panel of the printer.**

## Standby Mode

The printer has a standby mode where, after a period of inactivity, the printer goes into a sleep mode (low-power usage mode). This is indicated by the front panel display and status indicators turning off. The indicator light on the **Standby** switch is on when the printer is in standby mode. The printer “wakes up” whenever you press the **Standby** switch on the printer or there is any I/O activity such as receipt of a file.

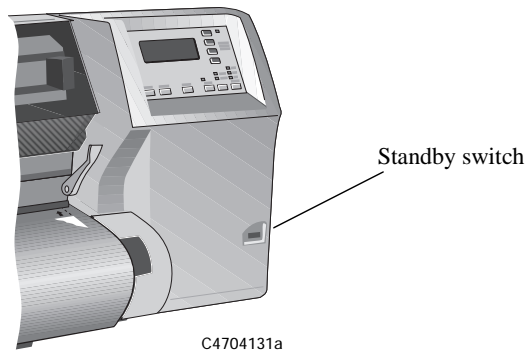

You can manually place the printer in standby mode by pressing the **Standby** switch when the printer is in normal operating mode. When you manually put the printer in standby mode, it will not “wake up” until you press the switch again.

- Use the **Standby** switch to turn the printer off and on, rather than the **Power** switch on the back of the printer.
- Use the **Power** Switch only when you need to isolate the printer from the power source, such as, when you are disconnecting or connecting cables, or upgrading memory.

---

### NOTE

**To re-initialize the printer, press and hold the Standby switch for three or more seconds.**

## Printing the Current Configuration

The display section is used for setting the printer's configuration. You can print out a report showing the printer's current configuration by following the steps below.

- 1 Make sure that media is loaded. See page 3-13, *Loading Roll Media*, for loading information.
- 2 Press the ↑ and ↓ keys simultaneously to print the Current Configuration.

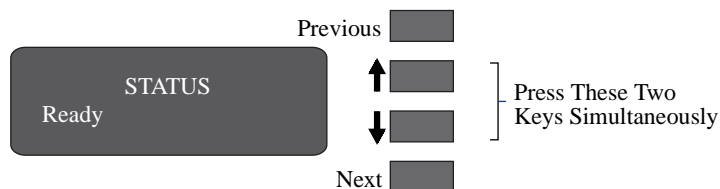

C4704019

The current configuration print fits on an A4 or US letter-size sheet. Keep this print for later reference.

## Entering the Menu System

- 1 Make sure a status screen is displayed, as shown in the example below:

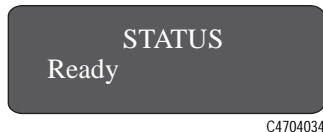

- 2 Press the **Enter** key.

Either the SHORT MENU screen



Only menus shaded yellow in front-panel menus print are accessible in Short Menu mode. (Shaded gray if printing in black only).

or the FULL MENU screen:



All menus are accessible.

is displayed, with the **Queueing & Nesting** option shown.

---

### NOTE

---

**You may not be able to access the menu system immediately, if the current task overrides it. If this happens, wait until the task is completed and try again.**

---

## Printing the Menus

You can see the complete menu structure available on the printer by printing the Front-Panel Menus print. To help understand the menu structure and its navigation, print it now:

---

### NOTE

**The Menu print is printed in the size specified in the Page Format → Size settings in the front panel. However if sheet media is loaded it will automatically shrink to fit. Make sure this setting specifies the size you want before printing.**

- 1 Make sure that media is loaded. See page 3-13, *Loading Roll Media*, for loading information.
- 2 On the front-panel display, go to Internal prints, as shown below.
- 3 Print the menu structure by selecting the Menu option from the Internal prints menu, as follows:



C4704034

- a** Press **Enter**.



C4704034

Note: Your front-panel display may show FULL MENU, not SHORT MENU, depending on your printer settings. You can print the internal prints in either mode.

- b** Press ↓ until Internal prints is displayed.

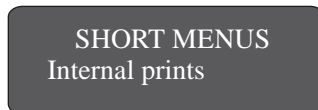

C4704034

Using the Front Panel  
Printing the Menu

- c Press **Enter**.
- d Press ↓ or ↑ until Menu is displayed.



- e Press **Enter**.

The printer prints a menu tree of the entire front-panel menu structure. The Receiving light flashes while the file is being processed, and then the printer starts printing.

**2500CP Only**

Look at the Front-Panel Menu print. It shows the full menu structure. Here is a sample section of it concerned with image quality:

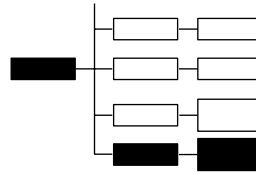
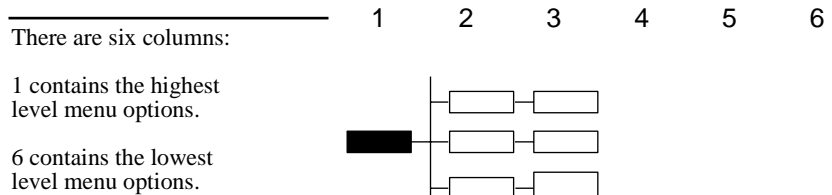

C4704039

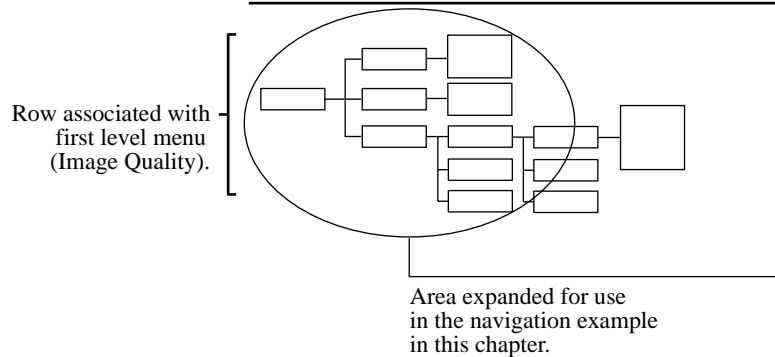



**2000CP Only**

Look at the Front-Panel Menus print. It shows the full menu structure. Here is a sample section of it (concerned with pen settings):

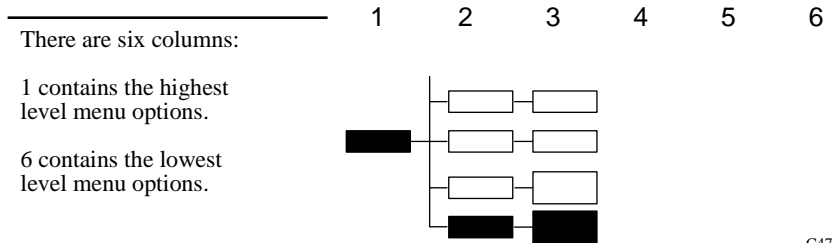

C4704005

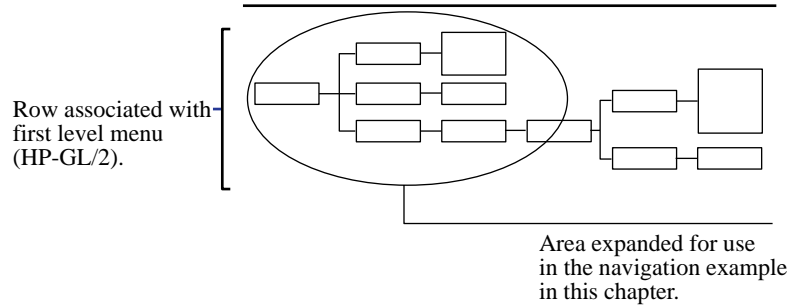

## Printing Other Internal Prints

In addition to the current configuration print and menu print, there are several other internal prints available in the printer. The internal prints are listed below:

---

### 2500CP Only

#### **PostScript demo**

Demonstrates the image quality capabilities of the printer.

#### **PostScript config**

The PostScript Configuration print shows the current configuration status of the printer's PostScript features.

#### **PostScript fonts**

The Fonts print shows all resident PostScript fonts (internal and downloaded) with a printed sample of each font.

---

#### **HP-GL/2 config**

The HP-GL/2 Configuration print shows the current settings for the printer's HP-GL/2 features.

#### **Usage report**

The Printer Usage Information print shows the status of the printer's usage counters. This information includes the total number of prints, number of prints by media size, number of prints by media type, number of prints per print mode, and total amount of ink used per color. The counts in this report are estimates.

#### **Image quality print**

The Image Quality print can be used to help diagnose whether the printer has image quality problems, and if problems exist, help determine the cause of image quality problems see chapter 11, *Troubleshooting*, for more information about this print.

## Service print

The Service print provides information needed for printer servicing, such as the current configuration, operating conditions (temperature and humidity), ink levels, and other statistics about printer usage.

- Menu

The Menu print shows the complete menu structure available on the printer to help you in locating menu options in the front panel.

## HP-GL/2 palette

The HP-GL/2 Palette print shows the color or grayscale definitions in the currently-selected color palette.

## Where to Find Internal Prints

The following internal prints are located under the Internal Prints menu:

---

### 2500CP Only

- PostScript demo
- PostScript config
- PostScript fonts

- 
- HP-GL/2 config
  - Usage report print
  - Menu print
  - HP-GL/2 Palette print

The following internal prints are located under the Service Tests option in the Utilities menu:

- Image Quality print
- Service print

## Navigating the Menu System

Once in the first-level menu, you can navigate the menu system using the display keys.

Press **Previous** to display the previous menu level, without changing any menu selections (equivalent to moving left [ $\leftarrow$ ]<sup>1</sup> one column in the Front-Panel Menus print).

Previous 

Press  $\uparrow$  to scroll up, or  $\downarrow$  to scroll down through the options in a menu (equivalent to moving up [ $\uparrow$ ] or down [ $\downarrow$ ] a column in the Front-Panel Menus print).

The option list is continuous, allowing you to move from the bottom to the top by pressing  $\downarrow$  or from the top to the bottom by pressing  $\uparrow$ .



Enter 

Press **Enter** to:

- select an option and move to the next menu level, when in the menu system (equivalent to moving one column to the right [ $\rightarrow$ ] in the Front-Panel Menus print).
- Change the printer's configuration to the displayed choice to the configuration, that is, selecting an option from the the lowest level menu [ $\downarrow$ ].

C4704006

<sup>1</sup>The colored arrows  $\uparrow\downarrow\leftarrow\rightarrow\leftrightarrow$ , shown in square brackets above, are used to represent pressing the relevant keys once, in the following navigation example.

---

### NOTE

**A  $\rightarrow$  character in a menu option box indicates that another level of menu is available.**

---

## Menu Graphics Used in This Manual

At the end of this chapter, there are some examples of navigating the menu system, showing all the menu displays available. In the rest of this manual, a menu graphic is displayed in the left margin when you need to use the menu system. This menu graphic gives a concise explanation of how to navigate to the exact place.

The graphics look similar to this, but further levels may be shown:

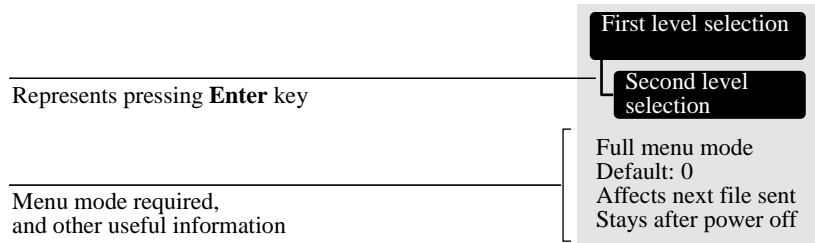

C4704018

Currently selected options are displayed with a \* in the front-panel display.

## Navigation Examples

Use the following examples to practice navigating the menu system. All examples assume that you have entered the menu system from the STATUS screen shown below.

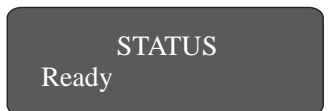

C4704034

### Selecting the Full Menu Mode

- ◆ Make sure the STATUS display level is shown on the front panel:

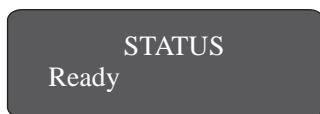

C4704034

- 1 Press **Enter**.



C4704008

If FULL MENU is displayed instead of SHORT MENU, press the **Previous** key and skip the following steps.

- 2 Press ↓ or ↑ until Utilities is displayed.

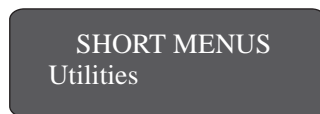

C4704034

- 3 Press **Enter**.



C4704034

4 Press **Enter**.



C4704034

5 Press ↓.



C4704034

6 Press **Enter**.



C4704034

7 Press **Previous**.



C4704034

8 Press **Previous** again to return to the STATUS screen in the front-panel display.

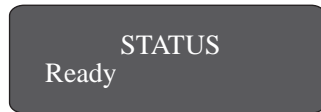

C4704034

## Changing the Color Calibration Setting in the Image Quality Menu

**2500CP Only**



In this example, you will change the Color Calibration setting in the Image Quality menu. The arrows on the excerpt from the Front-Panel Menus print on page 2-20 correspond to the numbered instructions. From the previous example, you should now have the STATUS screen displayed on the front panel, with FULL MENUS mode selected.

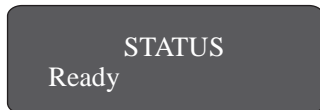

C4704034

- 1 Press the **Enter** key to enter the front-panel menu. You are now at the first level shown in the menu print.



C4704034

- 2 Press the ↓ key until IMAGE QUALITY is displayed.



C4704034

- 3 Press the **Enter** key to select the option and move to the IMAGE QUALITY settings second-level menu. The Ink emul. option is displayed.



C4704034

- 4 Press the ↓ key once to display the Color calibration option.

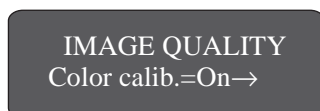

C4704034



- 5 Press the **Enter** key to select the option and move to the Color calibration third-level menu. The option currently selected is displayed with a \*.



COLOR CALIBRATION  
On\*

C4704034

- 6 Change the displayed option by pressing the ↓ or the ↑ key.



COLOR CALIBRATION  
Off

C4704034

- 7 Press the **Enter** key to set COLOR CALIBRATION to the new displayed setting. You will be returned to the IMAGE QUALITY second-level menu.



IMAGE QUALITY  
Color calib.=Off →

C4704034

- 8 To exit the menu system, press the **Previous** key twice.



STATUS  
Ready

C4704034

## Using the Front Panel Navigation Examples

If you now reenter the menu system and repeat steps 1 to 4, you will see the option that you selected displayed with a \*.

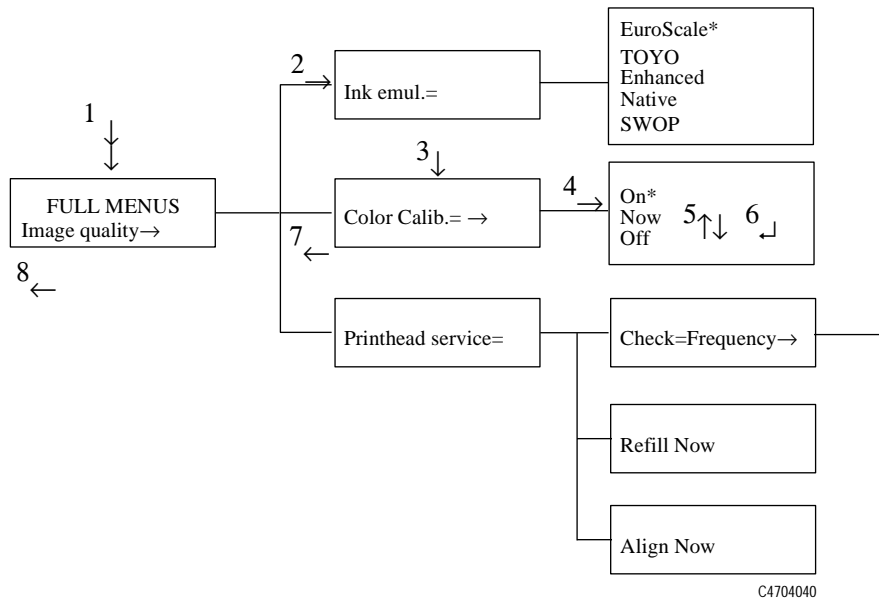

C4704040

---

### NOTE

---

A → character in a menu option box indicates that a lower level of menu is available.

## Changing the Merge Setting in HP-GL/2 Settings

In this example, you will change the Merge setting in the HP-GL/2 Settings. The arrows on the excerpt of the Front-Panel Menus print on the next page correspond to the numbered instructions. You should now have the STATUS screen displayed on the front panel, with FULL MENU mode selected.

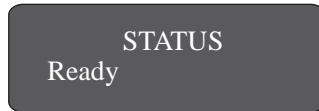

C4704034

- 1 Press the **Enter** key to enter the front-panel menu. You are now at the first level shown in the menu print.



C4704034

- 2 Press the ↓ key until HP-GL/2 settings is displayed.



C4704034

- 3 Press the **Enter** key to select the option and move to the HP-GL/2 settings second-level menu. The Palette option is displayed.

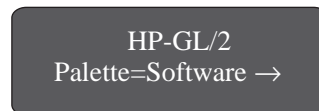

C4704034

- 4 Press the ↓ key once to display the Merge option.

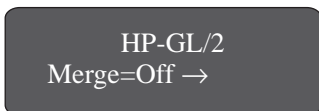

C4704034

## Using the Front Panel Navigation Examples

- 5 Press the **Enter** key to select the option and move to the Merge third-level menu. The option currently selected is displayed with a \*

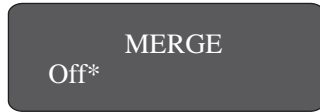

C4704034

- 6 Change the displayed option by pressing the ↓ or the ↑ key.



C4704034

- 7 Press the **Enter** key to set Merge equal to the new displayed value. You will be returned to the Merge second-level menu.

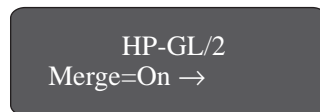

C4704034

- 8 To exit the menu system, press the **Previous** key twice.

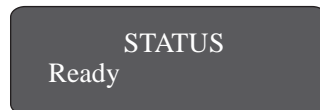

C4704034

If you now reenter the menu system and repeat steps 1 to 4, you will see the option that you selected displayed with a \*.

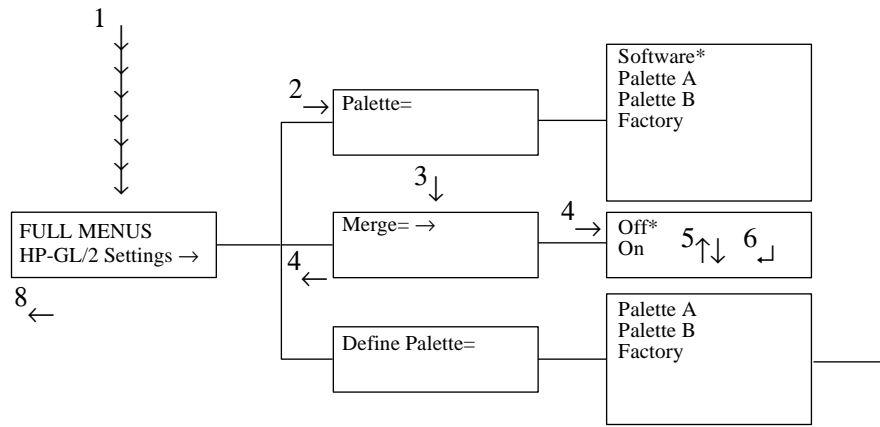

C4704009

**NOTE**

**A → character in a menu option box indicates that another level of menu is available.**

## Changing Margins

This example shows how to adjust the page margins.

- ◆ Make sure the STATUS display level is shown on the front panel:



C4704034

- 1 Enter the menu system by pressing the **Enter** key.



C4704034

Either the SHORT MENU screen or the FULL MENU screen is displayed with the Queueing & Nesting option. If necessary, see page 2-16, *Selecting the Full Menu Mode*, to change to full menu mode.

- 2 Press the  $\uparrow$  key or the  $\downarrow$  key until the Page Format menu is displayed.



C4704034

- 3 Press the **Enter** key.



C4704034

- 4 Press the  $\uparrow$  key, or the  $\downarrow$  key until the Margins option is displayed.



C4704034

- 5 Press the **Enter** key to display the MARGINS menu.



C4704034

- 6 Use the  $\uparrow$  and  $\downarrow$  keys to display the available options and, when the desired option is displayed, press the **Enter** key to select it as the setting for Margins.
- 7 To exit the menu system, press the **Previous** key twice.

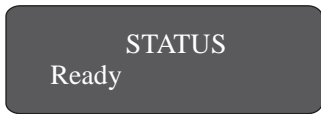

C4704034

## Changing the Drying Time

This example adjusts the drying time, a setting used to suit different environmental conditions, in the DRYING TIME menu. The printer must be in full menu mode for this example.

- ◆ Make sure the STATUS display level is shown on the front panel.:



C4704034

- 1 Press the **Enter** key to enter the menu system.



C4704034

Either the SHORT MENUS screen or the FULL MENUS screen is displayed with the Queueing & Nesting option. If necessary, see page 2-16, *Selecting the Full Menu Mode*, to change to Full Menu mode.

- 2 Press the  $\uparrow$  key or the  $\downarrow$  key until the Device Setup menu is displayed.



C4704034

- 3 Press the **Enter** key.



C4704034

- 4 Press the  $\uparrow$  key or the  $\downarrow$  key until DRYING TIME is displayed.

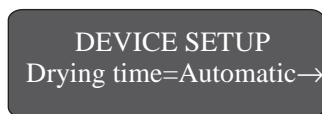

C4704034



- 5 Press the **Enter** key to display the DRYING TIME menu.

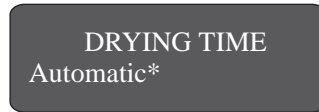

C4704034

- 6 Use the ↑ and ↓ keys to display the available options and, when the desired option is displayed, press the **Enter** key to select it as the setting for Drying time.
- 7 To exit the menu system, press the **Previous** key twice.

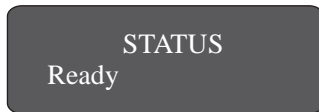

C4704034

## Other Types of Front-Panel Display Information

Other types of messages are also displayed in the front panel, such as those displayed for selecting media type during media loading:



C4704034

or the amount of ink remaining:

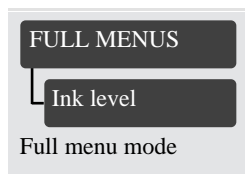

C4704041

There are other selection menus which are not part of the main menu system. These behave in the same way as the main menus. You scroll through the options using the ↑ and ↓ keys and select a displayed option using the **Enter** key.

---

# Working with Media

# 3

---

Choosing Media	3-2
Using the Ink System UV Outside	3-5
Handling Your Media	3-12
Loading Roll Media	3-13
Loading Media onto the Take Up Reel accessory	3-19
Unloading Media from the Take Up Reel accessory	3-26
Removing a Roll from the Printer	3-30
Installing a New Roll into the Printer	3-32
Changing the Core Tube on the Take Up Reel Accessory	3-35
Loading sheet media	3-39
Unloading Sheet Media	3-42
Drying time (With a Take Up Reel)	3-44
Drying Time (Without a Take Up Reel)	3-46

## Choosing Media

Your printer supports several types of media. Choosing the best media type for your needs is an essential step in ensuring good image quality. For best printing results, use only genuine Hewlett-Packard media, whose reliability and performance have been developed and thoroughly tested. All HP printing components (printer, ink system, and media) have been designed to work together to give trouble-free performance and optimal image quality.

For detailed information on Hewlett-Packard media, see page 3-4, *Supported Media Types*, and the *HP DesignJet Papers and Films* catalog supplied with the printer.

HP has tested some media products developed by a non-HP manufacturer. These tested products are approved by HP as compatible with this printer.

Some non-endorsed media products are listed in the *Media Guide for the HP DesignJet CP Printers* provided with your printer. HP has not tested these media products to ensure their performance or quality.

If you choose to print on a non-endorsed media it is recommended that you perform the Media Test Print see page 9-7, *Media Test Print*.

---

**CAUTION**

---

**Use of non-endorsed coated papers when printing with high ink volume may saturate the coated paper and could result in serious printhead damage.**

---

**CAUTION**

---

**For the Outdoor Durability Warranty, with the Ink System UV you must always print on the compatible 3M Opaque Vinyl media. Also you must use 3M Overlamine film to maintain the print's luster, depth and quality.**

## Some Important Points about Media Types

- This printer supports many media types. However, the quality of some images may be reduced if you do not use HP media.
- Whenever you load a roll or a sheet, the printer's front-panel display prompts you to specify the media type you are loading. It is absolutely essential to specify this correctly for good image quality. The table on page 3-4, *Supported Media Types*, gives you all the information you need. If media is already loaded and you are unsure which media type was specified, go to Utilities / Statistics in the front-panel menu. See page 8-2, *Viewing the Current Overall Configuration of the printer*.
- Make sure the appropriate print-quality setting (*Best, Normal or Fast*) is selected. You can set the print quality either from your software or from the printer's front panel (software driver settings override any print-quality settings made on the front panel). The combination of media type and print-quality settings tells the printer how to place the ink on the media - for example, the ink density, dithering method, and number of passes of the printheads. For more details, see the table on page 3-10, *Combinations of Media Type and Print Quality*.
- Included with this printer is an *HP DesignJet Papers and Films* catalog which gives ordering details for Hewlett-Packard media supplies. To get the latest version of this document, contact your local HP Sales and Support office.

---

### NOTE

---

**If you are using a third-party Raster Image Processor (RIP) to print with your printer, the above points may not apply. In this case, consult your RIP vendor for advice on media and the best settings for your requirements.**

## Supported Media Types

Your printer supports several types of media. The supported types and their most common uses are shown in the table below.

The media you choose will depend on the ink system you have installed that is, UV inks or imaging inks.

Media Type on the Front-Panel Display	Description
<b>Coated Paper</b>	A specially coated wood-pulp based paper for inexpensive high-quality color graphics and photographic image prints.
<b>High Gloss Photo Paper</b>	A white Photographic paper with a high -gloss finish for high quality prints.
<b>Semi Gloss Photo Paper</b>	A white Photographic paper with a semi-gloss finish for high quality prints.
<b>Imaging Film-Backlit</b>	A clear polyester film for backlit viewing of images.
<b>Opaque Vinyl</b>	Adhesive-backed white opaque vinyl.
<b>HP Heavyweight Coated Paper</b>	A specially coated heavyweight based paper for high quality color graphics which when combined with the HP DesignJet CP Ink System UV provides enhanced light fastness for indoor and outdoor use.
<b>3M Changeable Opaque Imaging Media</b>	A flexible white opaque film with removable pressure-sensitive adhesive backing for outdoor use. It is outstanding for outdoor signs, posters and banners. When printing with this media use the Best print mode.

**NOTE:**HP Heavyweight Coated Paper is the only media that is compatible with both the HP DesignJet CP Ink System and the HP DesignJet CP Ink System UV.

**NOTE:**To order the above media types see page 3-8, *HP Commercial Names of Media Types* and the pamphlet *Media Guide for the HP DesignJet printers*.

From time to time, new media types may become available. For up-to-date information, please contact your HP dealer or local HP Sales and Support Office.

---

# Using the Ink System UV Outside

## Laminating the Media after Printing

After you have printed a file using the HP DesignJet CP Ink System UV on 3M™ Changeable Opaque Imaging Media 8522CP and before displaying the print outdoors, it must be laminated with one of the 3M overlaminates (*see Table below*). The use of the overlaminate is essential for outdoor use to provide resistance to water, scratches and tears and to maintain the print's luster, depth and quality.

## Applying the Overlaminate to a Finished Print

---

### NOTE

---

**These guidelines provide a general process for laminating prints to help you maintain consistent results and best quality. The laminating process may vary, depending on the laminating equipment that you are using. Always refer to the manufacturer's documentation for safe operation and additional information.**

Before applying the laminate to your finished print, make sure it is completely dry. The print will feel almost dry immediately after printing, but if you are printing in a particularly cold or humid environment, the drying time may be longer than normal. For these situations wait 15 to 30 minutes before applying the overlaminate.

The 3M overlaminates are not heat-activated adhesives; however, heat can be used to improve the adhesive flow. The temperature should not exceed 68° C (180° F).

The recommended laminator pressure is a minimum of 15 psi, and must not exceed 75 psi.

Overlaminate Type	Description
<b>3M Lustre Protective Finish</b>	2mm vinyl overlaminate with pressure sensitive adhesive for outdoor use.
<b>3M Matte Protective Finish</b>	2mm vinyl overlaminate with pressure sensitive adhesive for outdoor use.
<b>3M High-Gloss Protective Finish</b>	2mm vinyl overlaminate with pressure sensitive adhesive for outdoor use.

## Installing the Final Print

### Recommendations to Follow When Installing the Final Print

Follow these recommendations when the final print is to be displayed outdoors:

#### ■ Installation temperatures

Final graphic installation temperature should range between 28° F and 110°F.

Final graphic removal temperature should range between 28° F and 110°F.

#### ■ Installation surfaces

The print must only be installed on flat, vertical surfaces. It is not recommended to install the final print over rivets or corrugations.

The surface should not be susceptible to fuel spillage.

The print must be flat, with minimum curvature and mounted in a vertical position with no more than  $\pm 10^\circ$  tilt.

Detergent-and-water application methods should not be used.

The surfaces that give easy print removal include; aluminum, painted metal (with good paint adhesion), Sintra board, acrylic, PVC banners and glass.

However all surfaces should be tested before applying the print.

If the surface has poor paint adhesion, paint may be pulled off when the final graphic is removed. Aged surfaces with surface oxidation or chalking may result in adhesive residue when the final print is removed.

#### ■ Installing on glass surfaces

The use of dark colors on your print may increase the risk of glass breakage. All glass has a tendency to absorb heat when exposed to sunlight. The ability of glass to resist breakage due to temperature stress is affected by size, thickness, quality of cut, edge treatment, tinting of the glass, and the frame design.

**NOTE:** Do not use very dark colors in window applications. Large areas of dark opaque colors could greatly increase the risk of glass breakage.



---

**CAUTION**

---

**Always apply the final print to the surface by hand or using a squeegee with a low friction paper sleeve.**

- 1** Position the final print on the surface. Measure the final print placement relative to the sides of the substrate.
- 2** Tape the full leading edge of the final print in the correct position. Two-inch wide masking tape is recommended for this.

**If the final print is less than 50 inches long:**

- a** Lift the final print up from the trailing edge. You can roll the final print up for easier handling, if desired.
- b** Strip back some of the backing from the final print holding it away from the surface with one hand.
- c** Starting at the leading edge (the taped edge), use your other hand to squeegee down the front surface of the final print. Use loose, easy motions to avoid stretching the final print.
- d** Remove the masking tape when you have finished.

**If the final print is more than 50 inches long:**

- a** Using two people, tape the middle of the final print to the surface and then lift it up from the trailing edge.
- b** Strip back some of the backing from the final print holding it away from the surface.
- c** Apply one half of the final print from its outer edge.
- d** Strip back some of the backing from the other side of the final print. Again holding it away from the surface, continue applying the final print from where you left off.
- e** Remove the masking tape when you have finished.

## Media Types

### HP Commercial Names of Media Types

The following table lists the common and HP commercial names of the media types supported by your printer.

Media Type on the Front-Panel Display	Commercial Name of Media as described in the Media Guide for printers	Also Known As
Coated paper	HP Coated Paper*	Color inkjet paper Matte paper Presentation
Heavy coated paper	HP Heavyweight Coated Paper*	Heavyweight coated paper Heavyweight inkjet paper Heavyweight color inkjet paper Heavyweight matte paper
High-gloss photo	HP High-Gloss Photo Paper*	High-gloss photo paper High-gloss paper
Semi-gloss photo	HP Semi-Gloss Photo Paper*	Semi-gloss photo paper Semi-gloss paper
Imaging film-backlit	3M Clear Imaging Media	Clear polyester film Backlit media
Opaque vinyl	Changeable Opaque Imaging Media (for Imaging inks)	3M Opaque vinyl
UV Opaque Vinyl	Opaque Imaging Vinyl (for UV inks)	3M Opaque vinyl

\*HP DesignJet CP Ink Systems are not compatible with media designed for previous HP DesignJet printer models and inks. Make sure your media is designed for HP DesignJet CP Ink Systems. See the *Media Guide for the HP DesignJet CP Printers* provided with your printer for information on compatible media.

## Physical Characteristics of Media Types

The following table lists the physical characteristics of the different supported media types.

Media Type on the Front-panel Display	Physical Characteristics	
	Opacity	Matte or Glossy
Coated paper	Opaque	Matte
Heavy coated paper	Opaque	Matte
High-gloss photo	Opaque	Glossy
Semi-gloss photo	Opaque	Semi-Gloss
Imaging film-backlit	Clear	Glossy
Opaque vinyl	Opaque	Glossy
UV Opaque Vinyl	Opaque	Semi-Gloss

**NOTE:**When loading media into the printer, make sure the coated side of the media is facing downwards.

**NOTE:**To order the above media types see page 3-8, *HP Commercial Names of Media Types* and the pamphlet *Media Guide for the HP DesignJet printers*.

## Combinations of Media Type and Print Quality

The table below shows possible combinations of media type and print quality.

Media Type on the Front-Panel Display	Print Quality (Set either on the Front Panel or in the Software)		
	Fast	Normal	Best <sup>a</sup>
Coated paper	Yes	Yes	Yes
Heavy coated paper	Yes	Yes	Yes
High-gloss photo	Yes	Yes	Yes
Semi-gloss photo	Yes	Yes	Yes
Imaging film-backlit	Yes <sup>b</sup>	Yes	Yes
Opaque vinyl	Yes	Yes	Yes
UV Opaque Vinyl	Yes	Yes	Yes

**a. Use Best mode to ensure that your print is the best quality possible.**

**b. Fast print mode is the same as Normal print mode for backlit media.**

**NOTE:** If you are using a third-party Raster Image Processor (RIP) to print with your printer, the above table may not apply. In this case, consult your RIP vendor for advice on the best settings for your requirements.

# Using Coated Paper and Heavy Coated Paper with Normal Mode

You should always select the media type in the front-panel menu that matches the media type you have loaded in the printer, **with the following one exception:**

## Printing on Coated Papers Using Normal Mode

- If you are loading Coated paper or Heavy coated paper, and you intend to print in Normal mode, you can select either **Coated paper** or **Heavy coated paper** in the front-panel menu selection.
  - For Faster Printing; select Coated paper media type in the front panel, although this is not recommended for images containing gradient fills.
  - For Better Print Quality; select Heavy coated paper media type in the front panel.

You should print images in both modes to see which gives the best results on coated paper for your images. The difference in print quality between the two modes may not be noticeable for some images.

## Handling Your Media

- Handle film and glossy media by the edges or wear cotton gloves. Skin oils can interact with the ink and cause it to smear.
- Although the standard ink systems supplied with this printer have excellent lightfastness, colors will eventually fade or change if exposed to sunlight over a long period of time.
- Handle 3M™ Changeable Opaque Imaging Media 8522CP carefully, avoid scratching and abrasions, especially after printing.
- When applying the final print avoid the application of excessive pressure and keep sharp objects well away. After printing, the print image is susceptible to scratching before the overlamine is applied.
- Rewrap partially used rolls if they are not being used and do not stack rolls.
- Always keep unused rolls wrapped in the plastic wrap to prevent discoloration.

## Loading Roll Media



To start this procedure you need to have a roll of media installed on to the printer spindle. See page 3-32, *Installing a New Roll into the Printer*.

- 1 Check the leading edge as it unwinds from the spool. If it is not evenly cut or if it is skewed (not perpendicular to the guides), continue with the next procedure. If the media is cut correctly go to step 3.

### WARNING



**The knife used in the next step is sharp. Be sure the printer's wheels are locked. Keep fingers clear of the cutting path. Keep the knife away from children.**

- 2 Trim the leading edge of the media roll only if it is not straight:
  - a Pull the media over the top of the machine and lay it over the cutting track.
  - b Use the knife in the pocket located on the back of the printer to cut off the first few inches of the media.
  - c Retract the blade and return the knife to its pocket.

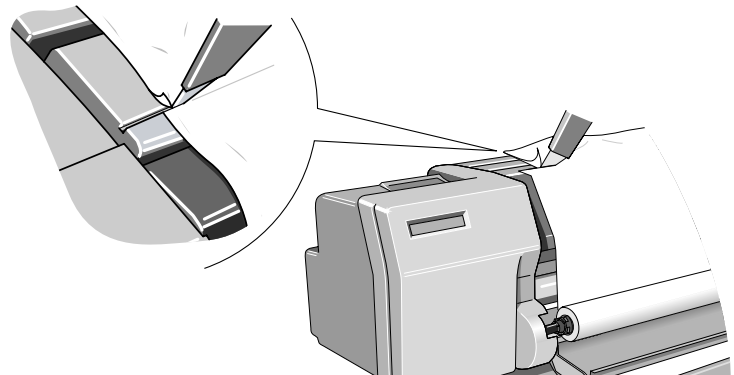

**NOTE:**Make sure the media lever is in the raised position.

- 3 Open the roll cover and insert the media into the printer.

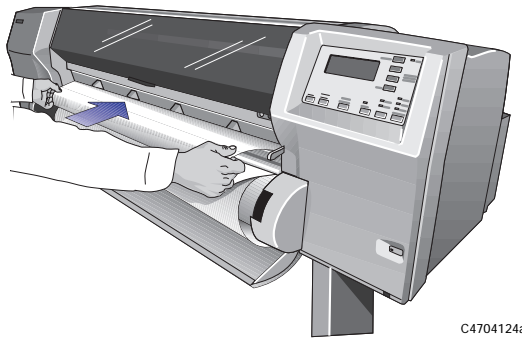

C4704124a

- 4 Holding the media at the sides, align its right edges with the perforated line on the entry platen

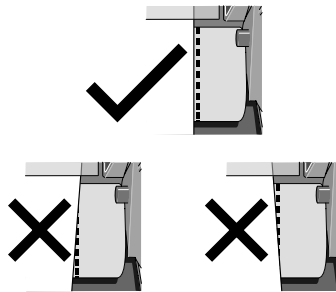

C472357

- 5 Press the ↓ key next to the front-panel display to indicate you are loading a roll.

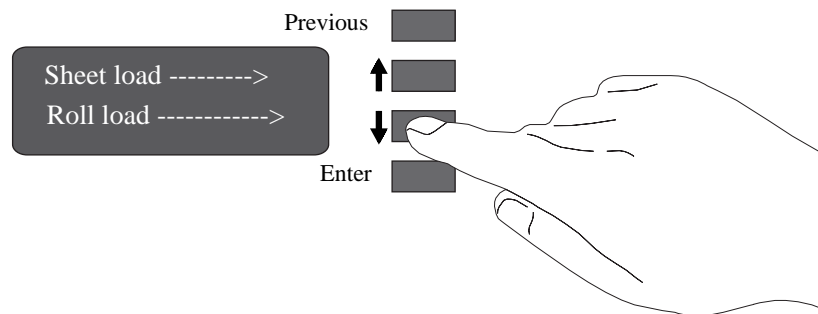

C4704029



- 6 Use the ↑ and ↓ keys until the display shows the type of media you are loading and then press the **Enter** key.

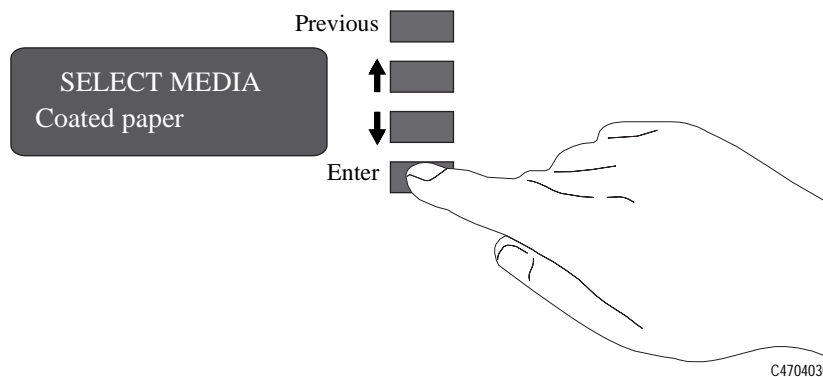

Working with Media  
Loading Roll Media

- 7 Align the media.
  - a When the front panel displays “**Lower Lever**”. Lower the media lever.



C4704034

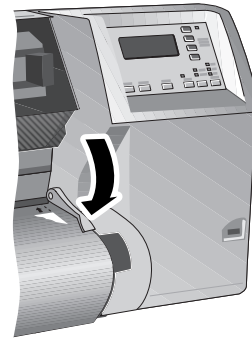

C4704130

- b The front panel displays:



Pull/Align  
edges to roll

C4704034

- c Take hold of the edges of the media now extending from the exit slot and pull the media toward you until taut. Then align the left and right edges of the media, so that they are flush with the edges of the roll.

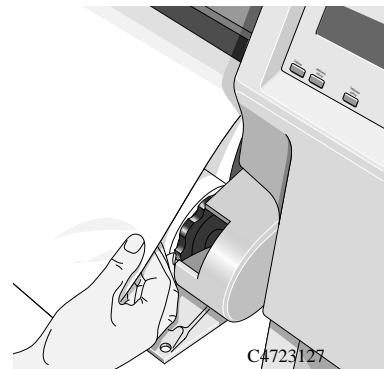
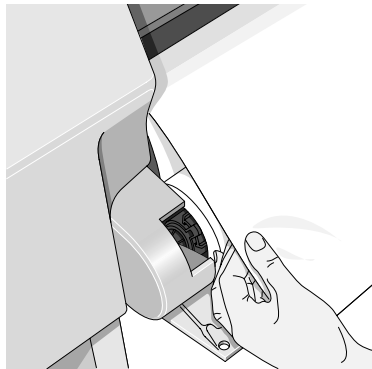

C4723127

- d** Wind the media stop in the direction of the arrow shown below. This is to take up any slack in the roll before closing the roll cover.

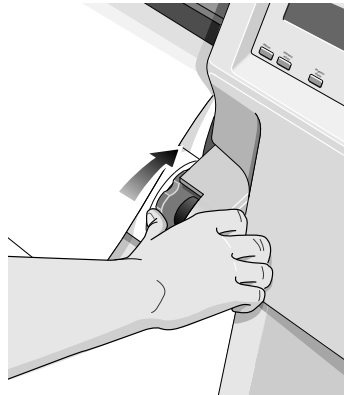

C4723128a

- e** When you have aligned the media lift the lever.

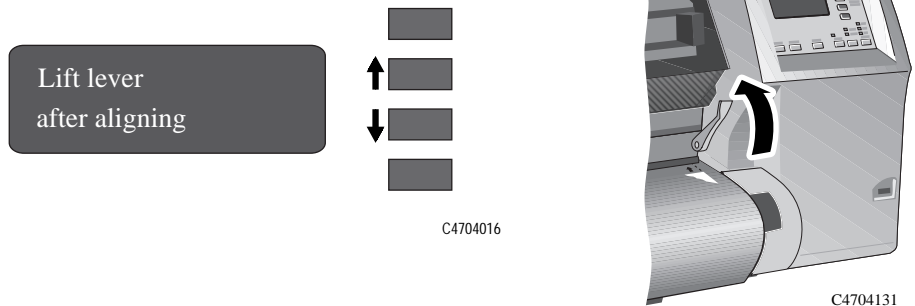

C4704016

C4704131

- f** The printer checks that the media is aligned properly. If the alignment is successful the front panel displays:

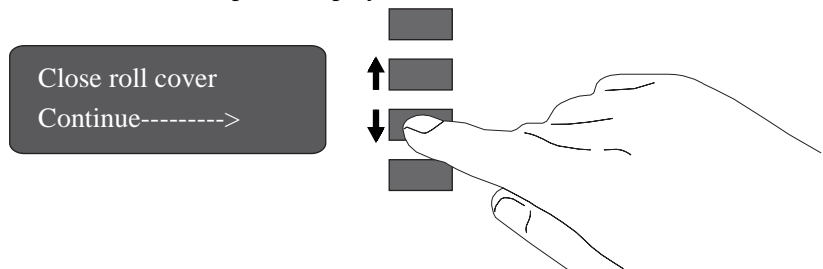

Working with Media  
Loading Roll Media

- 8 Close the roll cover and press the ↓ key.
- 9 When the ↓ key is pressed the next step depends on the type of printer you have:
  - a If you do **not** have a Take Up Reel installed the printer displays:



C4704016

- b If you do have a Take Up Reel installed and it is set to **ON**. Proceed to the next procedure.

**NOTE:** If you want to turn on or off the Take Up Reel, see page 8-12, *Turning on the Take Up Reel*.

## Loading Media onto the Take Up Reel accessory

To start this procedure you need to have a roll of media installed into the printer see page 3-32, *Installing a New Roll into the Printer* and 3-13, *Loading Roll Media*.

### CAUTION

**Using Back-lit media with a separate slip sheet is not recommended for use with the Take Up Reel.**

- 1 Move the leading edge of the media to half way down the Core Tube. To move the media down use the ↓ key as shown below. If the media has gone too far (i.e. passed the Core tube) use the ↑ key to move the media back up.

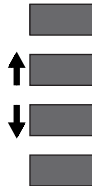
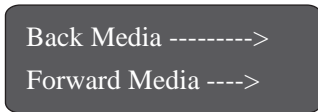

C4704016

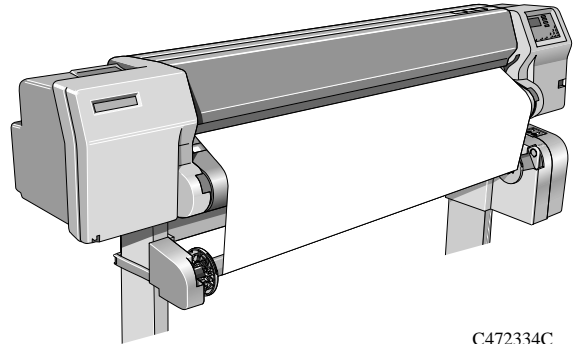

C472334C

**NOTE:**The Back Media/Forward Media display has a time-out of ten minutes. To return to this display go to Move Media in the front panel display.

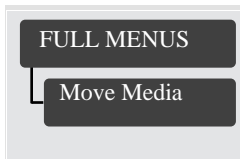

## Working with Media

### Loading Media onto the Take Up Reel accessory

- 2 Move the adjustment levers on the media guides to the unlocked position. 

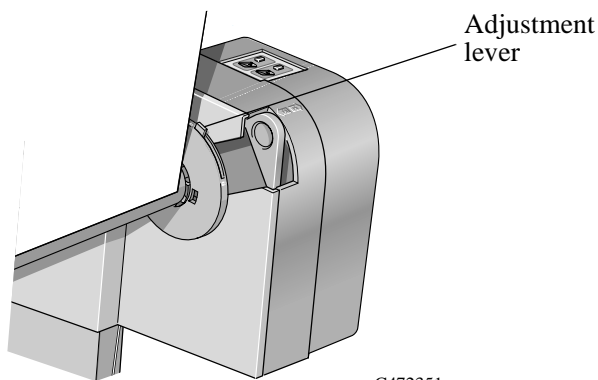

C472351

- 3 The two media guides and core must be positioned on the spindle so that the media is in the center, between the media guides. Adjust the media guides as shown below. The media guides may be slightly stiff on the spindle, you may have to use both hands.

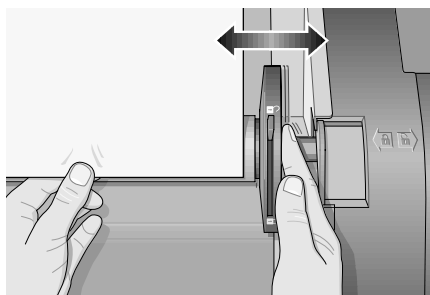

C472366

- 4 When the adjustment is made, pull the adjustment levers to the locked position. 

- 5 Pull the media down taut to the position shown below. Do not attempt to pull more media from the printer, if you need more media use the front panel.

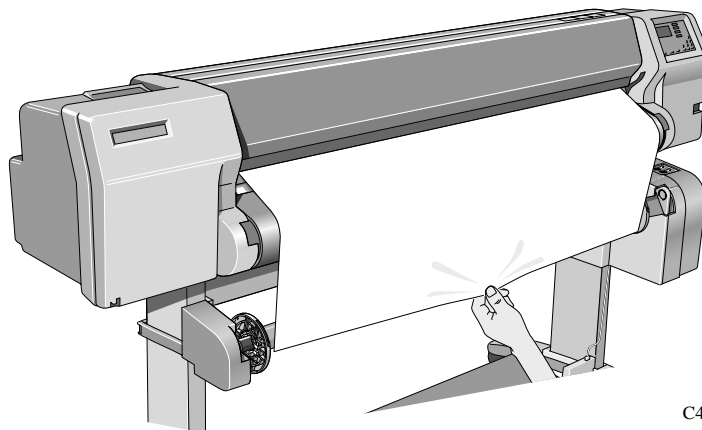

C472334

## Working with Media

### Loading Media onto the Take Up Reel accessory

- 6 Use a small amount of sticky tape (see note below) to attach the media to the core. Use three strips, one at each side of the media and one in the middle. Stick the middle one first.

**NOTE:** Use only tape which will not tear the media when it is removed later.

**NOTE:** To avoid the media skewing as it is wound onto the Core tube, ensure the media is straight when it is attached.

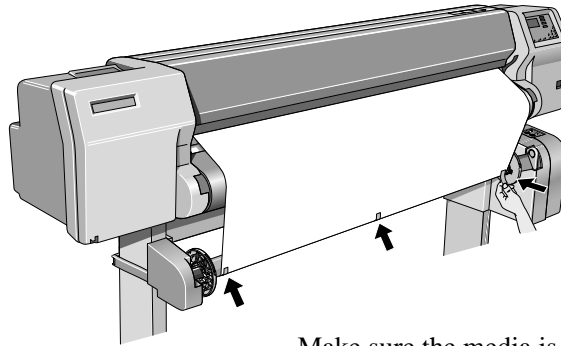

Make sure the media is straight with no creases

C472335

- 7 Press the ↓ key to advance the media. Enough media should be advanced so that the media can wrap at least once around the core so securing it fully onto the Take Up Reel.

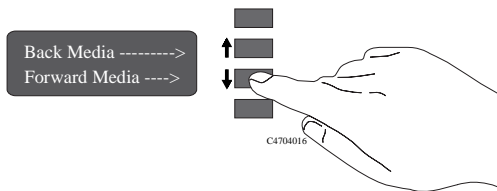

C4704016

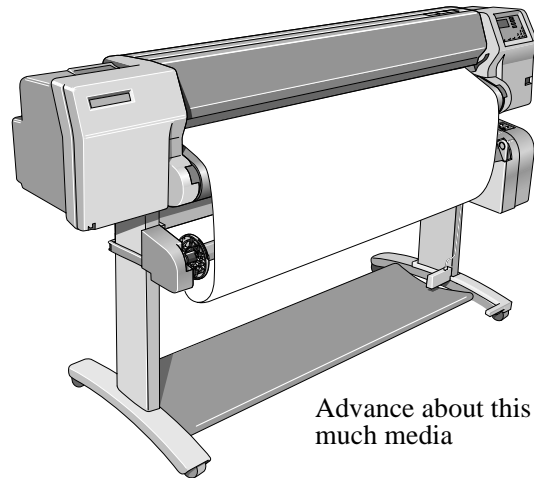

Advance about this much media

C472336



- 8 Important:** Press the media wind button on the Take Up Reel panel indicated below to wind the media once around the core.

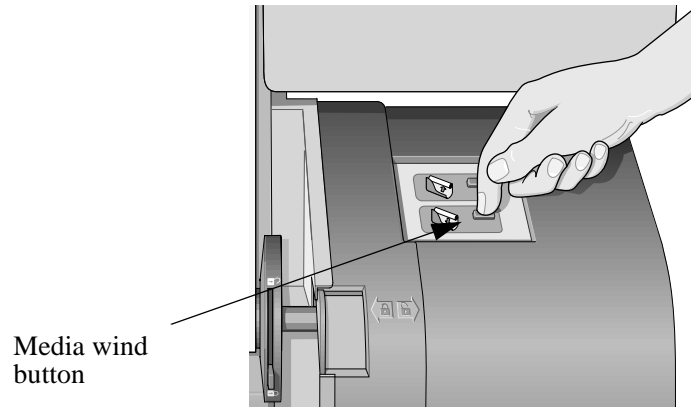

C472337

## Working with Media

### Loading Media onto the Take Up Reel accessory

- 9 Press the ↓ button on the front panel to advance some more media, advance about the amount shown below to enable you to insert the Media Weight

It is important that the Media Weight is the same width as the media you are using. By matching color coded lengths of plastic tube, you can make a Media Weight for different widths of standard media sizes: 24", 36".

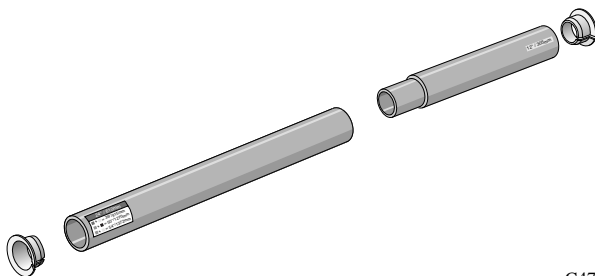

C470367

- 10 Carefully insert the Media Weight, ensure the end caps are installed and extend over the edges of the media.

### CAUTION

It is important that the media weight is inserted. The Take Up Reel will not function properly without it.

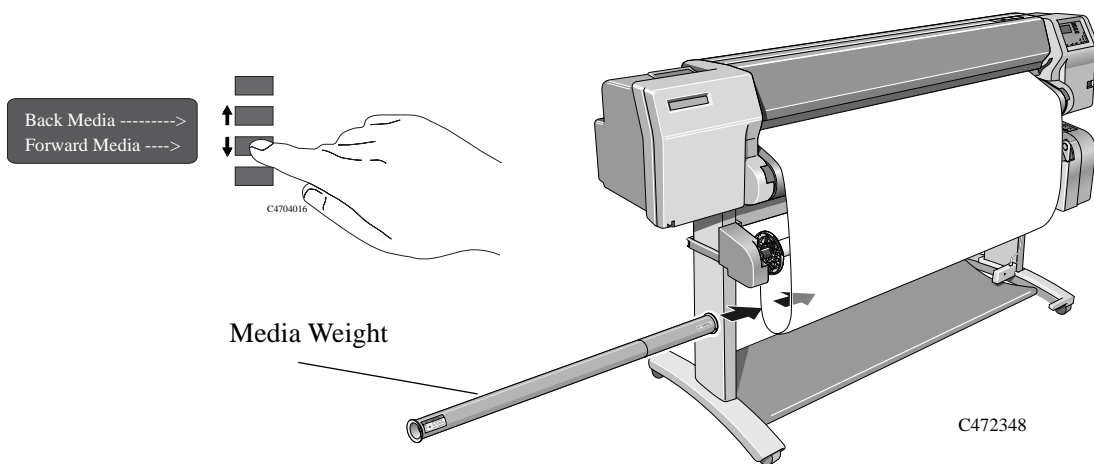

- 11 Press **Previous** or **Enter**. The front panel displays:



Ready

C4704034

**NOTE:** When the Take Up Reel is in operation it is important to ensure that the Take Up Reel sensor is not blocked.

- 12 Shown below is how the printer should look when it is in operation. As media is fed from the printer it drops down in a loop and up into the Take Up Reel spindle.

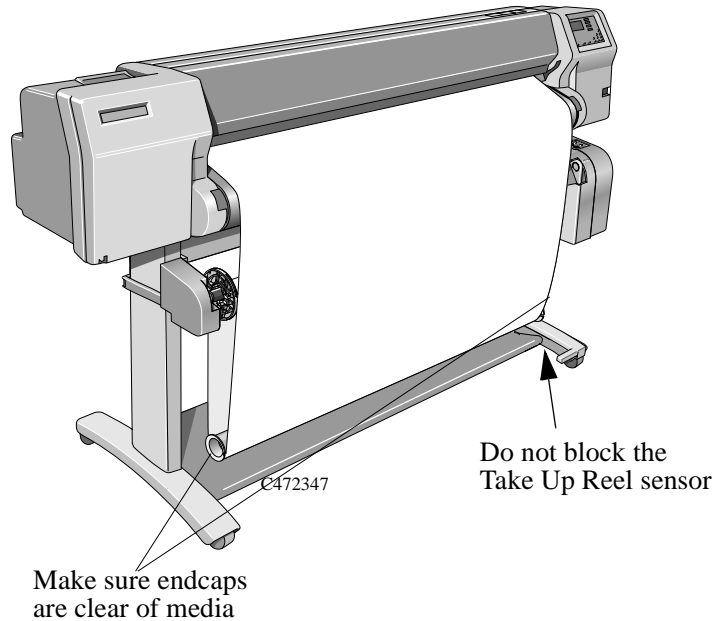

## Unloading Media from the Take Up Reel accessory

To remove media from the printer see page 3-30, *Removing a Roll from the Printer*.

To unload roll media from the Take Up Reel perform the following procedure.

**NOTE:** Before unloading media ensure the ink is dry; see page 3-44, *Drying time (With a Take Up Reel)*.

- 1 Press the Form feed and cut button on the front panel.

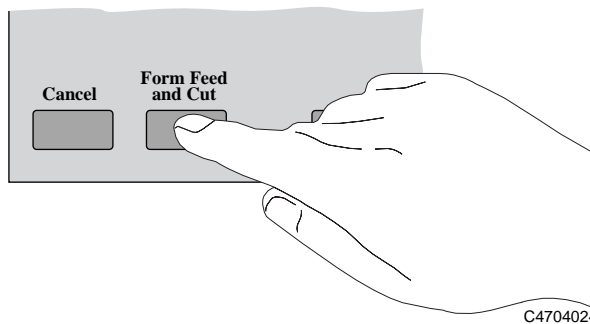

- 2 **Important:** Remove the Media Weight shown below. It may help you to remove the end-caps first.

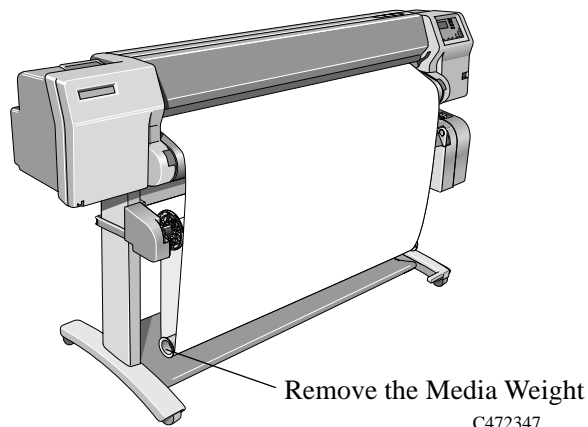

- 3 The front panel displays:

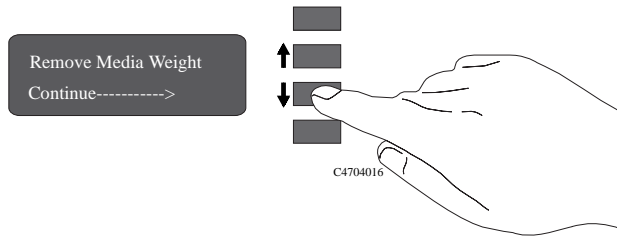

- 4 Press continue.
- 5 Press the media wind button shown below to wind the media hanging down onto the Take Up Reel. The front panel displays:

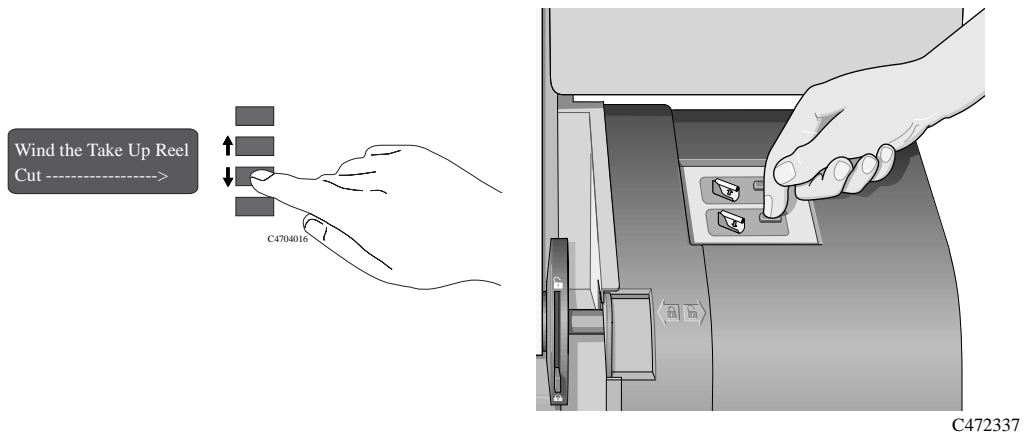

- 6 After winding up the Take Up Reel press the ↓ key. The cutter cuts the media.
- 7 Press the media wind button again on the Take Up Reel until the media is wrapped around the core.

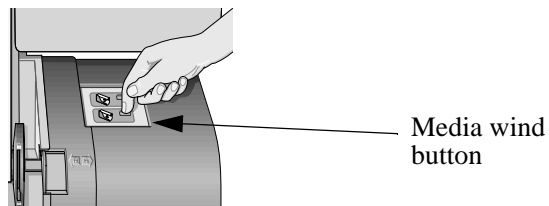

## Working with Media

### Unloading Media from the Take Up Reel accessory

- 8 Slide open the spindle lock on the right hand side of the Take Up Reel.

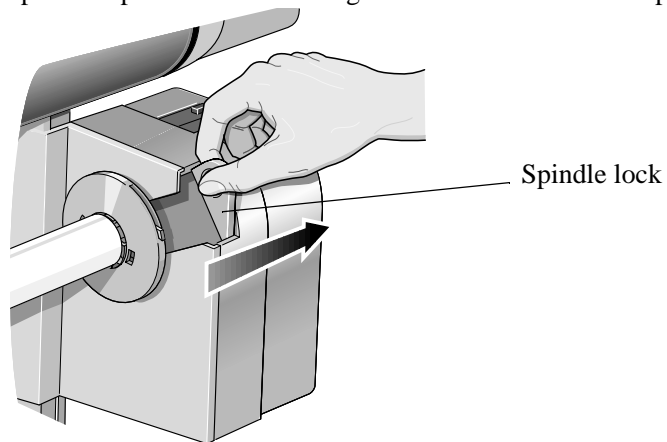

C472358

- 9 Remove the Take Up Reel spindle.

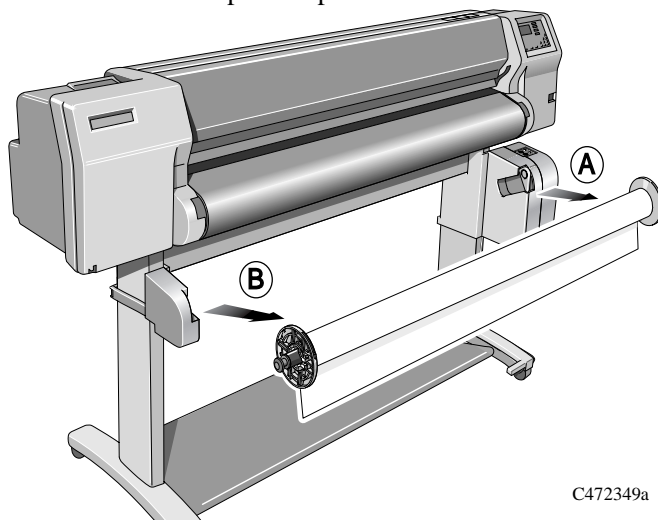

C472349a

- 10 Remove the Take Up Core from the Take Up Reel spindle.

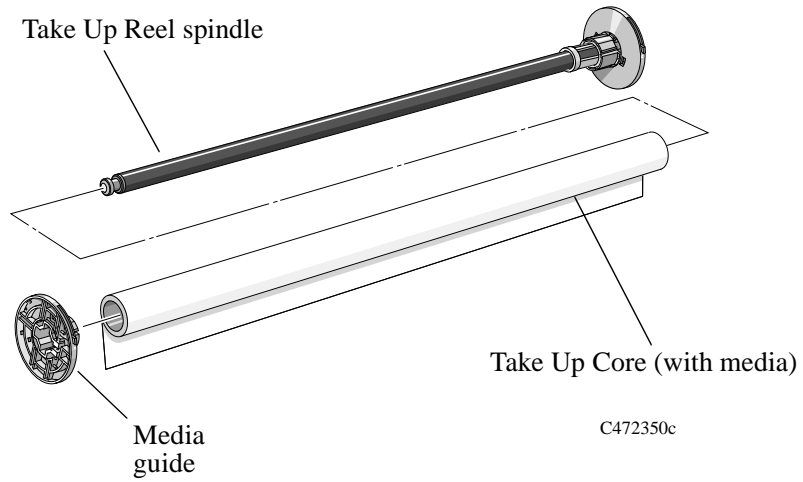

To remove roll media from the printer perform the following procedure.

## Removing a Roll from the Printer

- 1 Wait until the appropriate drying time has passed See page 3-44, *Drying time (With a Take Up Reel)*
- 2 Lower the Media lever.

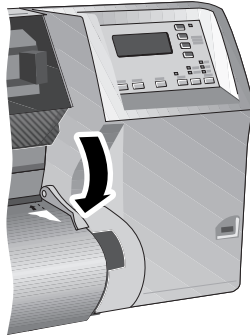

C4704130

- 3 Open the roll cover and turn the media stop to wind the media out of the printer and onto the roll.

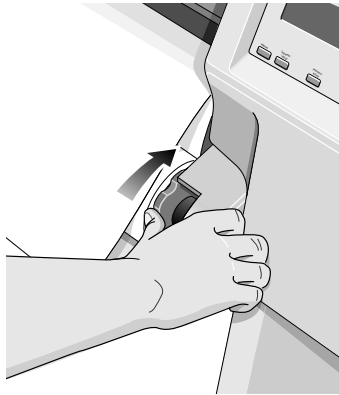

C4723128a



- 4 Remove the old roll by pulling firmly on each end of the spindle, A then B.

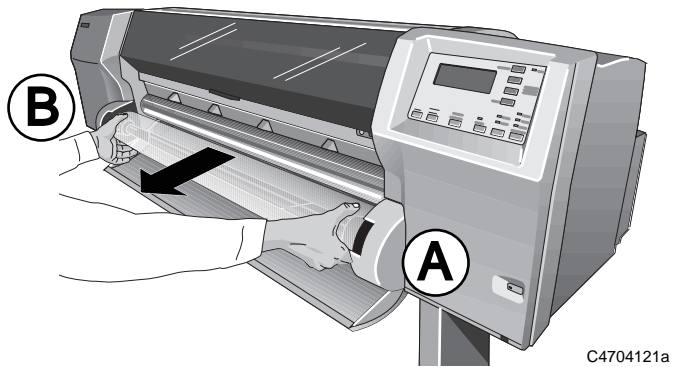

- 5 Rest the old roll vertically so that the fixed spindle media guide is on the floor. Pull out the removable spindle media guide and then remove the roll of media from the spindle.

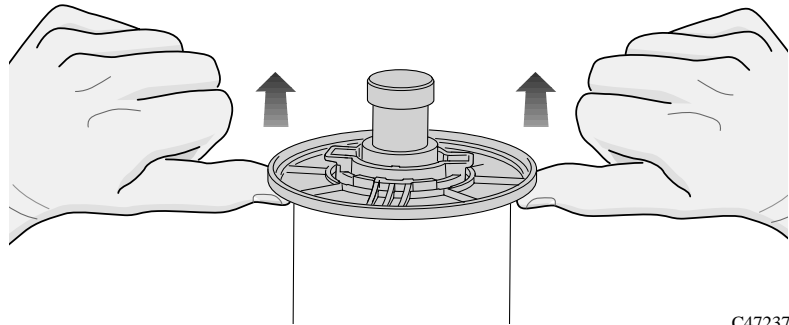

- 6 You have completed removing the old roll media from the printer. If you are not immediately loading another roll of media into the printer, replace the removable spindle media guide onto the spindle and install it back into the printer.

*To load a new roll of media, continue with the next section, Installing a New Roll into the Printer.*

## Installing a New Roll into the Printer

- 1 If an empty spindle is installed in the printer, open the roll cover and remove the empty spindle by pulling firmly on each end, A and then B as shown below.

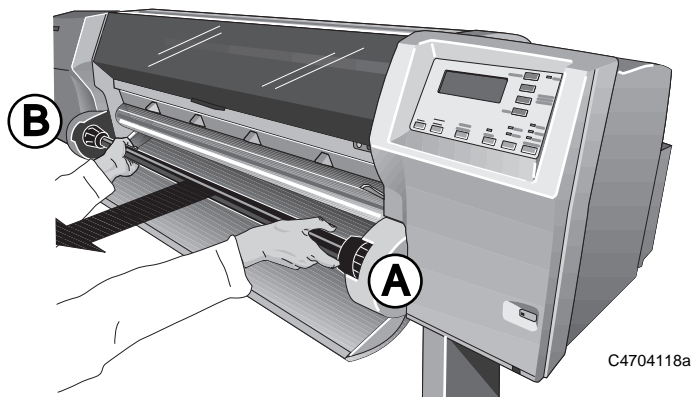

- 2 Remove the new roll from its wrapping.
- 3 HP Heavyweight Coated Paper is the only media that is compatible with both the HP DesignJet CP Ink System and the HP DesignJet CP Ink System UV. Therefore, if you have changed the Ink System and the media you are loading is incompatible with the new Ink System, the printer will automatically reject the non-compatible media. See page 3-2, *Choosing Media*.

- 4 Place the spindle vertically on the floor, with the fixed spindle media guide at the bottom. Take off the removable spindle media guide from the top of the spindle, and slide the new roll onto the spindle. The leading edge of the media must wind clockwise as shown below.

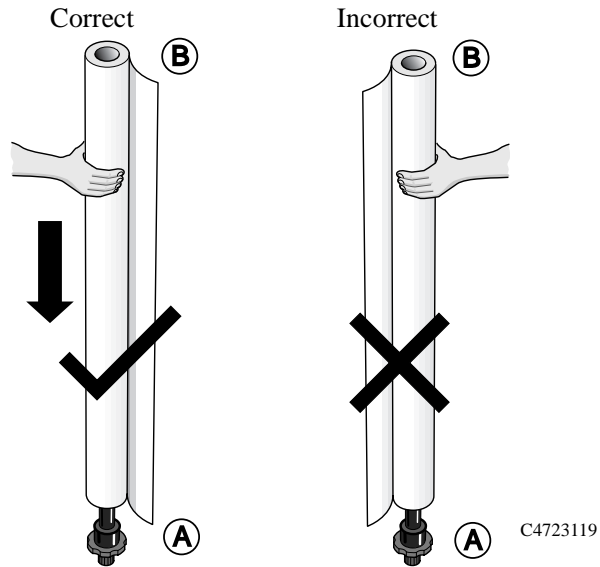

- 5 Install the removable spindle media guide onto the end of the spindle.
- Push down on the media guide, making sure that the guide is flush against the ends of the roll.
  - Then push the middle section in.

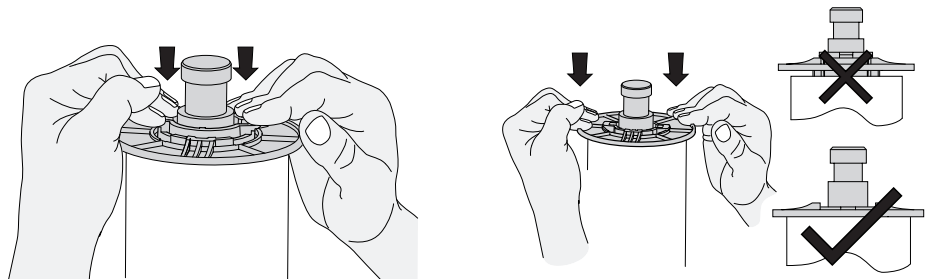

## Working with Media

### Installing a New Roll into the Printer

- 6 Insert the printer spindle so that the fixed media guide is on the right (A) and the removable media guide is on the left (B). Push in firmly on both ends. Make sure the media remains flush against the media stop.

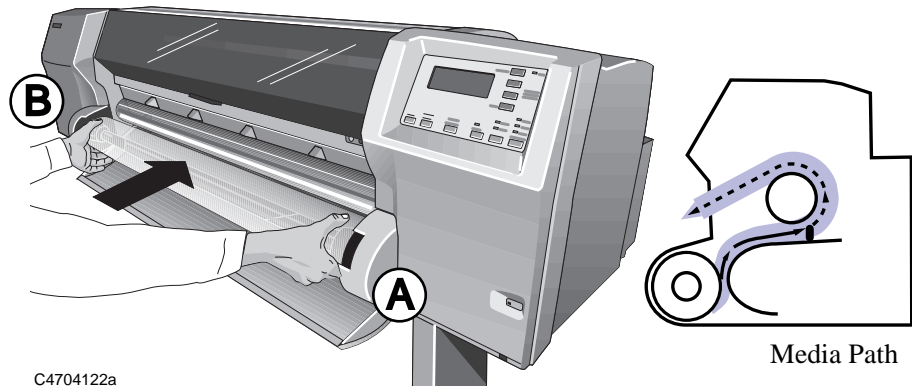

The media must be positioned on the roll as shown above.

## Changing the Core Tube on the Take Up Reel Accessory

The Core tube on the Take Up Reel must be the same width as the media you are using. To change the core perform the following procedure.

- 1 Slide open the spindle lock on the right hand side of the Take Up Reel.

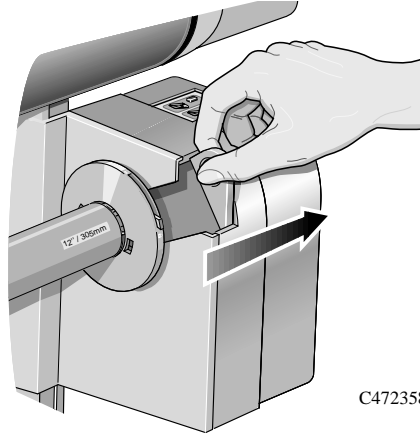

C472358

- 2 Remove the Take Up Reel spindle from the printer as shown by pulling firmly on each end of the spindle, A then B.

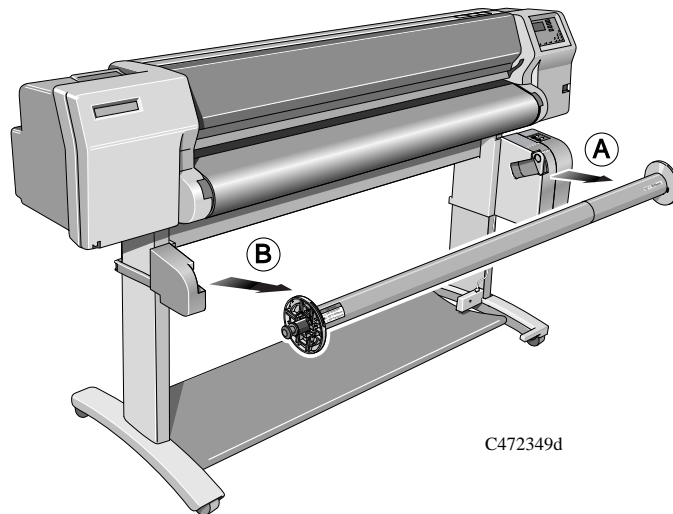

C472349d

## Working with Media

### Changing the Core Tube on the Take Up Reel Accessory

- 3 Remove the left-hand media guide.
- 4 Remove the old Take Up Core.
- 5 Install the new Core you have chosen onto the spindle and re-install the left hand guide assembly.

**NOTE:** You can also use an empty cardboard tube to replace the plastic Take Up Core that was supplied with your printer.

It is important that the Take Up Core is the same width as the media you are using. By matching color coded lengths of plastic tube, you can make a Take Up Core for different widths of standard media sizes: 24",36".

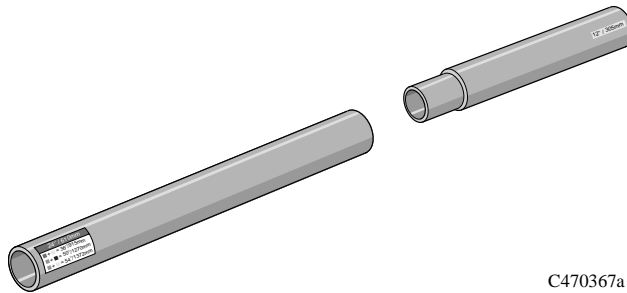

C470367a

Alternatively you can use an empty media cardboard core.

**NOTE:**Ensure the Take Up Core is pushed firmly into both media guides.

**NOTE:**If you want to use a three inch cardboard core then use the 3 inch core adaptors shown below.

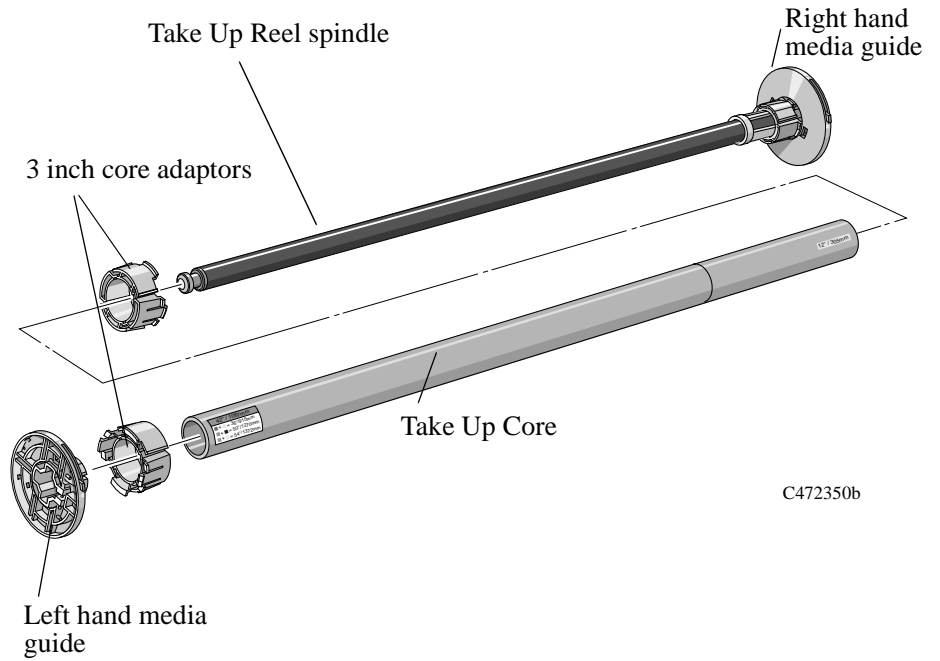

C472350b

## Working with Media

### Changing the Core Tube on the Take Up Reel Accessory

- 6 Install the Take Up Reel spindle into the printer by pushing firmly on each end of the spindle, A then B.

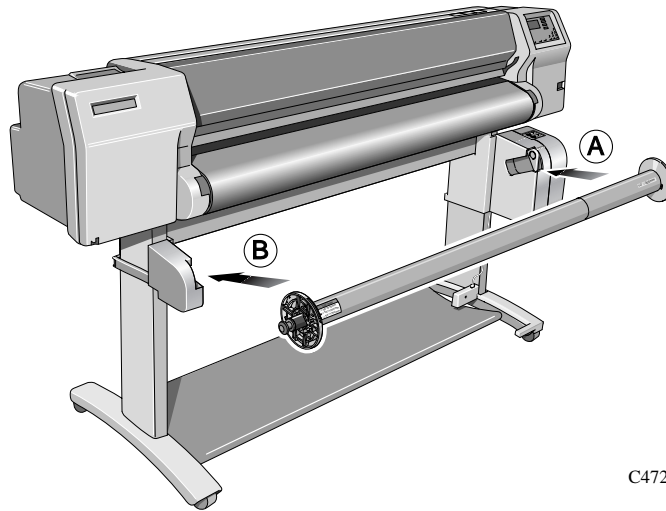

C472349b

- 7 Slide shut the spindle lock on the right-hand side of the Take Up Reel.

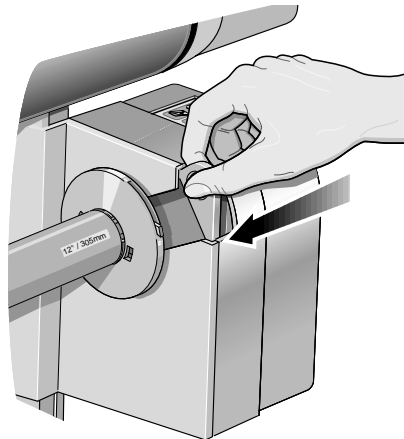

C472359



## Loading sheet media

### Which edge first?



You can load a sheet in either portrait or landscape orientation. Unless using the Rotate option (see page 5-15, *Rotating an Image*), load the sheet in the same orientation as you have specified in your software. If printing a PostScript file, always load the sheet with the short edge first, even if the width of your drawing is greater than its length.



C4723020

(short edge first)  
always use this orientation for PostScript files

### Which side up?

As you load the sheet, it is the side facing down on which the printer prints. With most media types, the two sides are different and so it is important to load the sheet correctly.

### Loading a sheet

- 1 You cannot load sheet media if roll media is loaded. If roll media is loaded refer to 3-30, *Removing a Roll from the Printer*.
- 2 Make sure the media lever is in the raised position and the roll cover is closed.

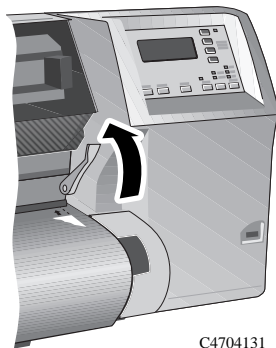

C4704131

Working with Media  
Loading sheet media

- 3 Holding the media at its sides, align the right edge with the perforated line on the entry platen.
- 4 Insert the media into the printer until it buckles slightly. That is, push it all the way until the media stops. Let go of the media when the printer begins to pull it in.

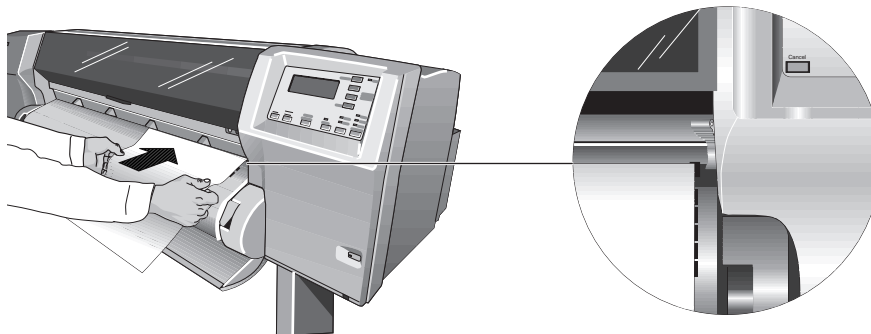

C4704129a

- 5 Press  $\uparrow$  next to the front-panel display to indicate you are loading a sheet.

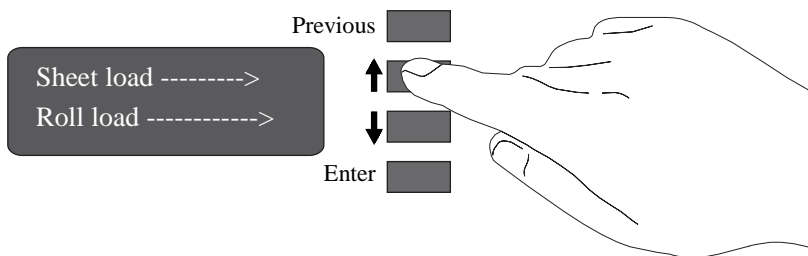

C4704035

- 6 Using the  $\uparrow$  and  $\downarrow$  keys until the display shows the type of media you are loading\*. Then press the **Enter** key.

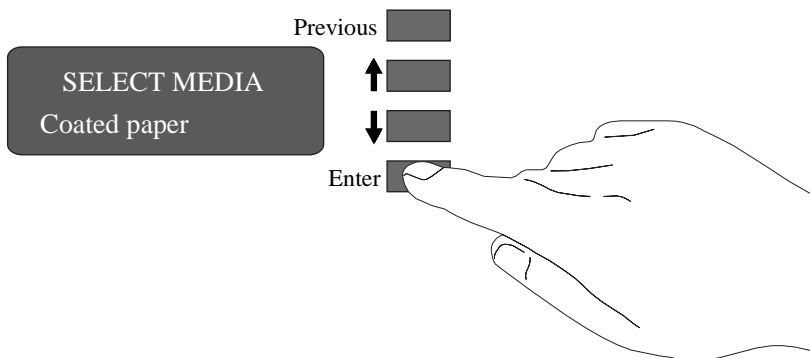

C4704030

\*For information on media types, see page 3-2, *Choosing Media*.

- 7** The printer moves the sheet in and out to check its size and alignment, and then advances it to the start of the page.
- 8** When the “Status/Ready “ message is displayed you have finished loading sheet media.

## Unloading Sheet Media

- 1 Wait until the appropriate drying time has passed (see page 3-44, *Drying time (With a Take Up Reel)*). No drying time is necessary for some combinations of media types and print modes.
- 2 Gently pull the sheet from the printer.

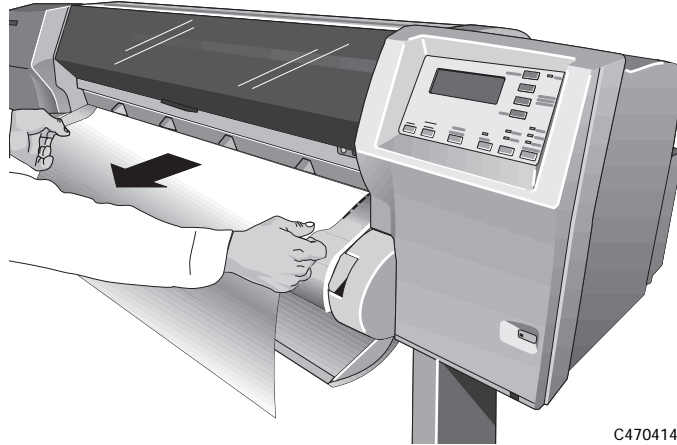

C4704141a

Device Setup

Skew tolerance

Full menu mode only  
Default: Off

## Compensating for Badly Cut Media

If the media is persistently difficult to load, it could be an indication that it has been cut unevenly, with the media width on the leading edge different to that of the trailing edge. A front-panel option called Skew tolerance helps you compensate for the shape of some poorly cut sheet media. When you properly load the leading edge of poorly cut media along the perforated line on the platen, you may notice the trailing edge is displaced from the line by a small distance and the printer will not accept the media. The printer can accept poorly cut media that is displaced less than 1.0 cm from the perforated line.

The Skew tolerance feature is enabled only when Sheet media is selected on the front panel.

---

### NOTE

---

**Media that is cut properly should not need the help of the skew tolerance feature. In fact, using this feature for properly cut media increases the risk of skewing your print on the page.**

## Adjusting Skew Tolerance

Select the appropriate skew tolerance in the front panel.

Skew Tolerance in Front Panel	Maximum Acceptable Skew of Loaded Sheet
Off	0.4 cm
On	1.0 cm

## Drying time (With a Take Up Reel)

If you are using the Take Up Reel the ink must be dry before the media is wound up onto the Take Up Tube, otherwise the image will be damaged. In most cases the Take Up Reel paper loop gives the print time to dry before it is wound up, in this case the printer will not slow down.

However sometimes the printed media will need a longer time than this to dry, and so the printer will slow down the printing process to allow more time before being wound onto the Take Up Reel, this is called the Drying Time.

There are three settings to Drying Time:

### **None**

This setting means there is no delay to the printing process.

Hewlett-Packard has tested the HP media range in different environmental conditions. The table below shows media which may need drying time and what conditions are required to avoid it.

<b>HP Media Type</b>	<b>Width of printing area</b>	<b>Max.% Relative Humidity</b>	<b>Max. Temperature °C</b>
High-gloss photo	24 inches or more	60	30
Semi-gloss photo	24 inches or more	60	30
Imaging film-backlit	24 inches or more	50	35

### Automatic

This is the default setting. The printer (if necessary) will automatically adjust the drying time depending on the following:

- Type of Media
- Print Mode
- Width of printing area
- Environmental conditions

---

**CAUTION**

---

**To avoid the printer adding drying time to prints operate the printer under the following environmental conditions:**

HP Media Type	Width of printing area	Max.% Relative Humidity	Max. Temperature °C
High-gloss photo	24 inches or more	50	30
Semi-gloss photo	24 inches or more	50	30
Imaging film-backlit	24 inches or more	40	35

### Manual

In this mode you can override the amount of time that the printer has calculated to print your plot. The time shown in the front panel will be the amount of time that it will take to reach the Core on the Take Up Reel.

**NOTE:** However there is a certain amount of time that the printer has to take to process your job, if the amount of time that you have specified is less than this time the printer will ignore your setting.

## Drying Time (Without a Take Up Reel)

On some media types, the ink needs time to dry before the media is unloaded. The printer automatically determines the appropriate drying time, based on the type of media you have selected and the current temperature and humidity.

### Adjusting Drying Time

You can make a global adjustment to the printer's automatic drying times through the front-panel menus. In almost all situations, the Automatic setting will provide excellent results.

Drying time setting	Result
Automatic*	The printer automatically adjusts the drying time for the current humidity and temperature.
Manual	You can specify the drying time, from 1 to 10 minutes.
None	The printer ejects the media immediately after printing, without waiting for the ink to dry.

\*For environmental specifications, see page 13-6.

---

### CAUTION

---

**Adjusting drying times only to speed up the printer can reduce the quality of your print.**



---

# Working with Ink Systems

# 4

---

About the Ink System 4-2

Obtaining Optimum Refill Performance using non-HP media. 4-6

Monitoring the Ink Level 4-9

Removing and Replacing Ink Systems 4-11

After replacing the Ink System 4-23

Removing and Storing Partially Used Ink Systems 4-24

Storing the Ink System in the HP DesignJet CP Ink System Storage  
Container 4-25

## About the Ink System

### The HP DesignJet CP Ink Systems

There are two HP DesignJet CP Ink Systems designed together with your HP DesignJet 2500CP and 2000CP printers for a total printing solution that delivers clear, sharp prints - every time.

- The HP DesignJet CP Ink System UV also referred to as UV Pigmented ink is designed for use in applications where durability to direct sunlight is needed. Because the ink has different characteristics than the Imaging Ink, prints will not look exactly the same. The HP DesignJet Ink system UV is available from your local Hewlett-Packard printer dealer.

**NOTE:**The Imaging and UV inks are very different in composition. Be careful when installing and storing ink systems, never mix ink system components.

### Main Features of the HP DesignJet CP Ink System

Designed with the HP DesignJet 2500CP and 2000CP printers the HP DesignJet CP Ink System (Imaging Ink) delivers clear, sharp, brilliant photo-quality images with precise performance - every time.

- The HP DesignJet CP Ink System (Imaging Ink) provides convenient, easy-to-use printing for photo-quality images.
- The HP DesignJet CP Ink System is the Ink System that you received with your HP DesignJet CP printer.

## What is an Ink System?

In each of the four ink systems, there are three separate components that work together. The components of each ink system are color-coded to help you install them correctly.

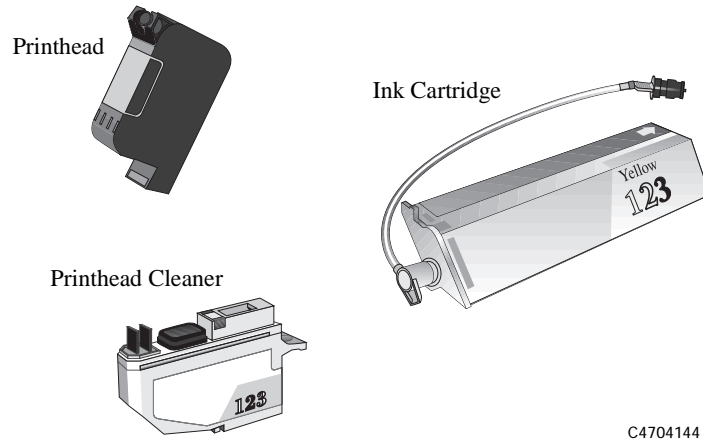

C4704144

### **Ink Cartridge**

Each ink cartridge is a large-capacity ink supply that refills the printhead whenever the ink volume in the printhead drops below a minimum level.

### **Printhead**

The printhead has a 600-dpi thermal inkjet head for firing ink droplets onto the media and a reservoir which holds enough ink for several prints. The actual number of prints between refills depends on the size and type of images you are printing.

### **Printhead Cleaner**

The printer uses the printhead cleaner to clean and maintain the printhead to ensure best possible image quality, and to seal the printhead when not in use to ensure long life.

## How to Identify the HP DesignJet CP Ink System UV Components

The appearance of the HP DesignJet CP Ink System UV is similar to the HP DesignJet CP Ink System. To help you easily identify the UV Ink System each component is marked with the following symbol after the name HP DesignJet CP Ink System UV:



Be sure to check all components; printhead, printhead cleaner and ink cartridge for this symbol.

Additionally, you can also identify the Ink System components by their part number (Refer to Chapter 13, *Reference*).

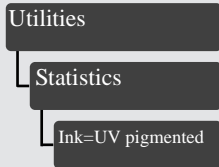

### Identifying the Ink System in the Printer

The printer automatically detects the Ink System installed. You can easily check which Ink System you are using from the front-panel menu display.

- 1 Make sure the front-panel display reads **STATUS / Ready**.
- 2 Press the **Enter** key and then using the  $\uparrow$  or  $\downarrow$  key, scroll through the menu until **Utilities** is displayed.
- 3 Press the **Enter** key and then using the  $\uparrow$  or  $\downarrow$  key, scroll through the menu until **Statistics** is displayed.
- 4 Press the **Enter** key and again using the  $\uparrow$  or  $\downarrow$  key, scroll through the menu until you find one of these two messages:
  - **Ink=UV pigmented** (the HP DesignJet CP Ink System UV is installed)
  - **Ink=Imaging** (the HP DesignJet CP Ink System is installed)
- 5 To return to the **STATUS / Ready** display, press the **Previous** key three times.

## **When Does the Ink System Refill the Printheads?**

Normally the printheads are refilled when a print has been finished. If you are printing an image with a high ink density which is larger than E/A0, the printer may stop during the print to refill. The printer contains algorithms to find the best place in a print to stop for a refill. If you are using UV pigmented ink, you may not be able to print a large image without the printer stopping to refill the printheads.

## Obtaining Optimum Refill Performance using non-HP media.

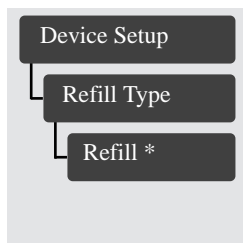

In some cases, particularly with high ink density prints and using non endorsed media types, defects can occur as the ink dries on the media while a print is paused to refill the printheads. If you are experiencing this problem you can change the way the printer refills. Your printer can use three different refill types, they are optimized for different types of media. The three refill types are called A, B, C or default. The printer chooses which refill type to use based on the media type and the print mode selected in the front panel. These options may be supported for other types of media by your RIP software if you are using a RIP. The table below shows you which refill type you are already using, you can if necessary change the refill type to better suit the media you are using.

**Default:** This refill type is for the HP Media range. The printer chooses the refill type depending on the HP Media you are using and the print mode selected. **If you change Media type the printer will always return to this refill type.**

**Refill A:** Works well for coated papers, however it may cause hazing (blurry, non-glossy surface) on some glossy media.

**Refill B:** Works well for glossy media, but may leave a very thin line on some media.

**Refill C:** Shorter refill time, can avoid hazing and other defects on some media types, but does not completely refill the printheads, so more refills may occur during very large prints.

Media for Imaging Ink	Fast	Normal	Best
Coated	B	B	A
Heavy Coated	B	A	A
Imaging Film-Backlit	A	A	A
High Gloss Film	B	B	B
Semi-Gloss Photo	B	B	B
High-Gloss Photo	B	B	B
Opaque Vinyl	C	C	C
Media for UV ink	Fast	Normal	Best
Heavy Coated	A	A	A
UV Vinyl	B	B	B
UV Custom Media A	B	B	B
UV Custom Media B	A	A	A
UV Custom Media C	A	A	A
UV Custom Media D	B	B	B

**NOTE:**The refill types shown are the default settings.

**NOTE:**If the media type is changed either by loading new media or changing the setting in the front panel, the refill type will return to default.

**NOTE:**If you are using an external RIP, the option indicated through the RIP will override the Front Panel selection.

## Refilling the Printheads from the Front Panel

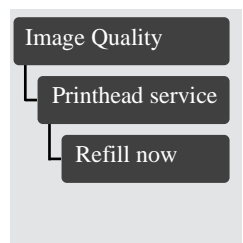

You may want to refill the printheads before printing a very large (long axis) or dense print that may require more ink than the minimum volume in the printhead. Select Refill in the Printhead service menu. Refill causes the printer to refill all four printheads immediately. If a file is being printed when you select Refill, the printer waits for the current print to be completed before refilling the printheads.

### How big a print can I make without a refill?

The printheads contain enough ink for almost all E/A0 size jobs. The table below shows the possible area at 100% ink coverage.

<b>Ink System</b>	<b>Always</b>	<b>If you Refill before start of print</b>
<b>Imaging Inks</b>	0.75m <sup>2</sup> (8ft <sup>2</sup> )	1.0m <sup>2</sup> (10.5ft <sup>2</sup> )
<b>UV Inks</b>	0.67m <sup>2</sup> (7ft <sup>2</sup> )	0.75m <sup>2</sup> (8ft <sup>2</sup> )

If you are printing on backlit media, you may only be able to print half the area before a refill occurs, this is because the printer needs more ink to print on backlit media.



## Monitoring the Ink Level



You can monitor how much ink you have remaining in each ink cartridge by selecting the **Ink level** display in the front-panel menu.

The display provides an indication of how much ink is remaining in each of the four ink cartridges (based on internal counts of the ink ejected).

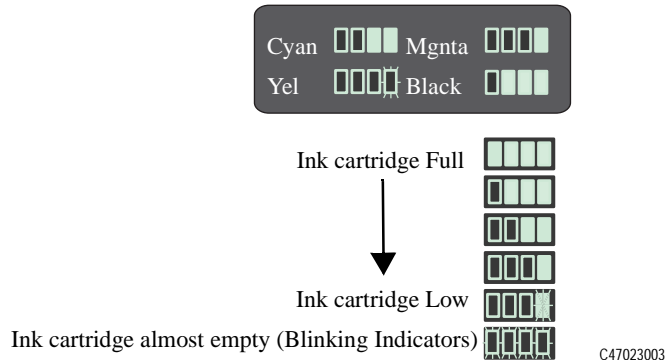

The display may not provide a precise measurement of the amount of ink remaining in the ink cartridges. The actual amount of ink left may vary depending on your ink system components and printer.

When the last indicator starts blinking, you may run out of ink at any time. If you do completely run out of ink, an “out of ink” warning message is displayed on the front panel as soon as the printer detects it. See page 4-10, *When should I Replace an Ink System?*

If you need to print several images unattended (for example, when printing overnight) and the Ink Level display shows that one or more ink systems is low on ink, you may want to replace these system with new ink systems. See page 4-24, *Removing and Storing Partially Used Ink Systems.*

## When should I Replace an Ink System?

You should replace an ink system when prompted by the printer. When the printer runs out of one or more colors of ink, the printer displays the following message on the front panel.



The printer displays four blocks representing the four ink colors with empty ink systems shown as blinking empty blocks. The printer displays the colors in the same positions as installed in the printer.

The “Out of ink” message will be displayed for the following reasons:

- The printhead check detects too many non-working nozzles in the printhead and at the same time it is low on ink.
- The printer stops printing due to an abnormal increase in the temperature of the printhead (normally because there is no ink), and at the same time it is low on ink.
- The ink level monitor estimates that the ink system has used so much ink that it is beyond all possible ink-consumption tolerances.

---

### NOTE

**It is recommended that you set the printhead check frequency to 1 (see page 9-6, *Checking Printheads*) if you see any of the printheads low on ink and you plan to leave the printing working unattended. By doing this you can limit the number of prints wasted due to printheads out of ink.**

---

## Removing and Replacing Ink Systems



**NOTE:**It is very important that you do not mix ink systems up. The UV ink systems and other non-UV ink systems are not compatible. Contamination of one ink system with the other will result in you having to replace both the ink systems.

The front-panel display will prompt you to replace components in the following order:

- 1 Remove and replace printheads.
- 2 Remove and replace printhead cleaners.
- 3 Remove and replace ink cartridges.

The components of the ink system are numbered to match the sequence in which they must be installed. The number is printed on the printhead cleaner and ink cartridge, and on the sleeve containing the printhead.

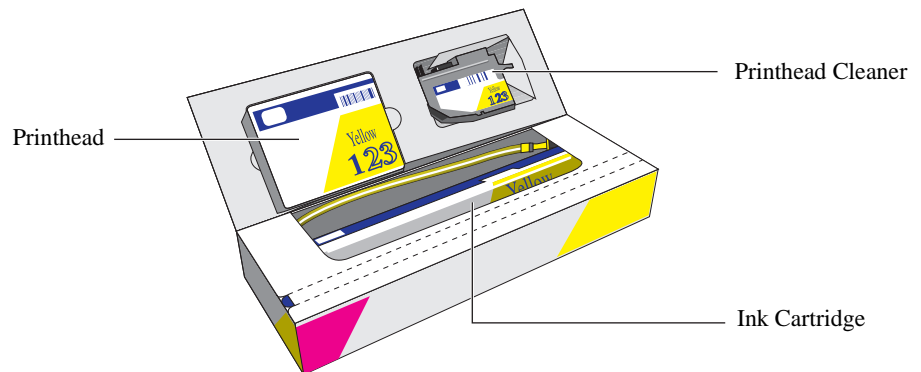

C2704112

**Remember:**

- Always change all three components for each ink color system at the same time.
- Use only the components that come together in their box. Never mix the components with the same or different colors from other boxes.
- Never mix Imaging Ink Systems and UV Ink Systems or components, the printer will not work.

## Working with multiple Ink Systems

### IMPORTANT

To get the best images from your HP DesignJet CP Ink System UV always follow these important rules:

- Change all three components for each ink color set together. The printhead, printhead cleaner, and ink cartridge should all be new every time you replace a color *unless they have been previously used together and stored in the HP DesignJet CP Ink System Storage Container.*
- Make sure all four ink colors that you are using are the same type of HP Ink System. *Never mix UV Pigmented ink and Imaging ink Systems.*
- If you have installed mixed ink components in the printer, the front panel will display the following message; “Replace mixed printhead(s) ■■ X ■■“. You will not be able to use the printer until the mixed ink components have been replaced. See page 11-31, *Solving Ink System Problems* for more information.
- Install all three components of the ink system by the date on the box.

---

### CAUTION

---

**If you are removing an ink color from the printer and intend to use it later, always keep the three components together as a set.**

## Handle Ink Systems with Care



Handle the ink system with care. In particular, the printhead is a high precision device and needs proper handling.

- Do not touch the printhead nozzles.
- Do not be rough when handling the printheads. Always set them down gently.
- Do not drop the printheads.
- Proper handling will assure optimum performance throughout the printhead life.
- For the printhead cleaner, always handle and store upright to avoid potential leaking of the ink.

# Replace the Ink System

## **1** Removing and Replacing Printheads

- 1 When the printer carriage stops and the front panel displays the message “*Open window to access printheads,*” open the window of the printer.

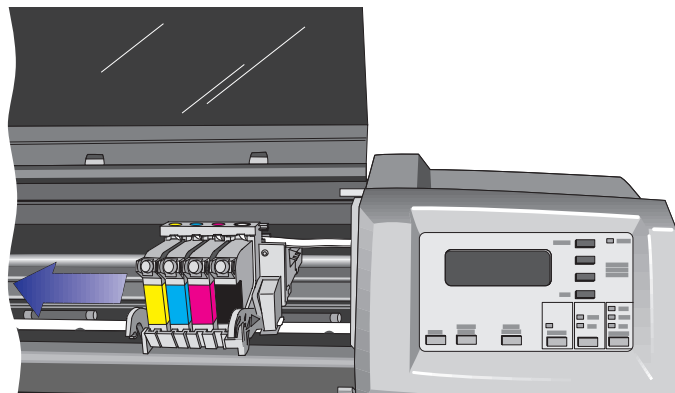

C4704140

**NOTE:**Do not open the window before the “Open window to access printheads” message is displayed. Follow the instructions in the front-panel display. If there are any problems during the installation, the printer will give you instructions in the front-panel display. Descriptions of all front-panel messages and instructions on what to do are listed in chapter 12, *Front-Panel Messages*.

## Working with Ink Systems

### Replace the Ink System

After you open the window, the printer will display the following message on the front panel. Blinking indicators show which printheads must be replaced. In the following example, the yellow printhead needs to be replaced.

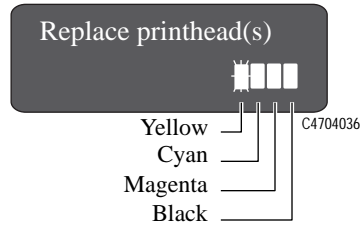

- 2 Press down lightly on the printhead you are replacing and pull it toward you, removing it from its stall as shown below. Discard the used printhead.

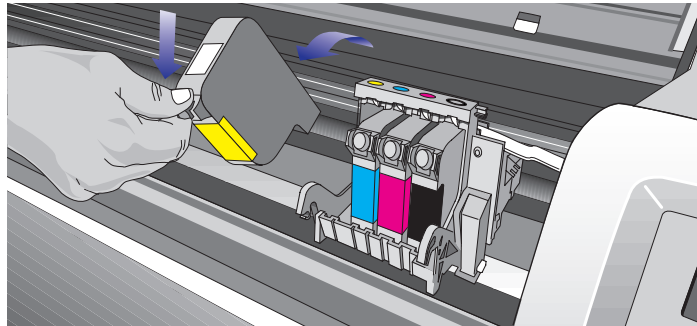

C4704135

**NOTE:** If you print mostly in Fast mode or extremely heavy image densities, inspect the carriage for ink residues whenever you replace the ink system(s).

- 3 Take the new printhead and remove the colored protective tape from the printhead's nozzles.

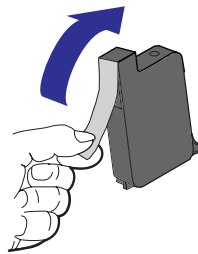

C4704046

- 4 Insert the printhead into the stall with the color dot that matches the color of the printhead label. Press down lightly and push the printhead away from you (toward the back of the cradle) until it snaps into place as shown below.

**NOTE:**The printhead colors can also be identified by the part numbers on the boxes. The sequence of the stalls is, from left to right; yellow, cyan, magenta, and black.

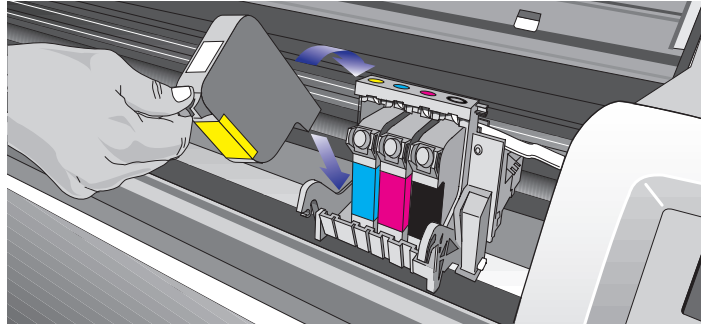

C4704136

- 5 Repeat steps 2 through 4 for any additional printheads you need to replace.
- 6 When you have finished replacing the printheads, the front panel displays the message “Close window to continue”.
- 7 Close the window, and the front panel will display the message “Open right door to access head cleaners”.
- 8 Continue with the next procedure, *Removing and Replacing the Printhead Cleaner*.

## 2 Removing and Replacing the Printhead Cleaner

---

**WARNING**

---

When you open the right door of the printer, the printhead cleaners move to the opening in the printer for replacement. Keep hands clear of the opening until the printhead cleaners stop moving.

- 1 Open the right door on the printer.

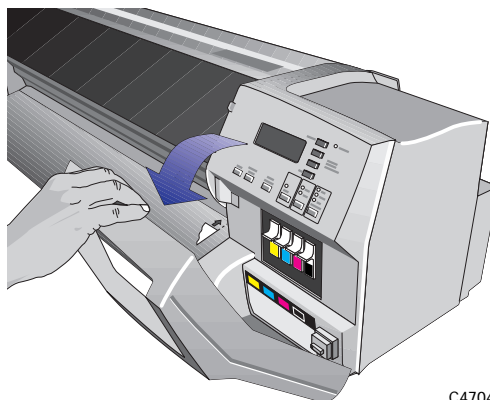

C4704114

After you open the right door, the printer displays the message shown below on the front panel. The blinking indicators show which printhead cleaner(s) must be replaced. In the example below, the yellow printhead cleaner needs to be replaced.



C4723036A



- 2 Press down on the printhead cleaner handle and pull it out of the printer. Discard the used printhead cleaner.

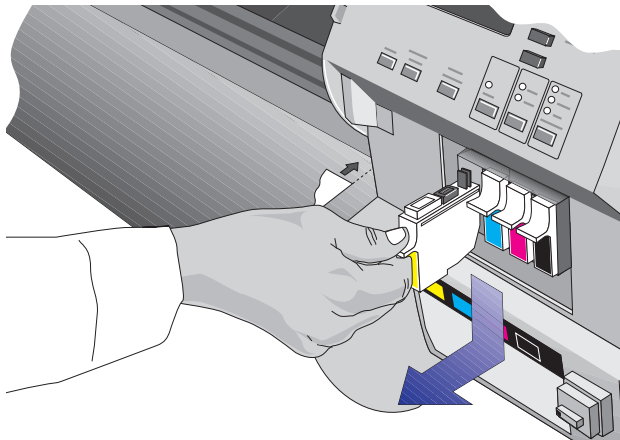

C4707138

- 3 Insert the new printhead cleaner into the matching color-coded slot in the printer.

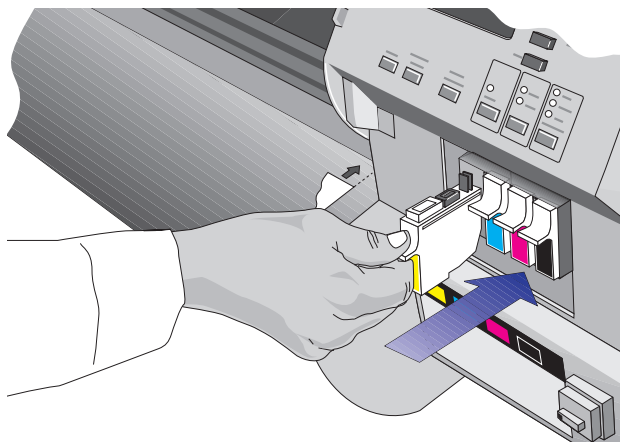

C4704139

- 4 Repeat steps 2 and 3 for any additional printhead cleaners you need to replace.

Working with Ink Systems  
Replace the Ink System

- 5 Close the right door on the printer.

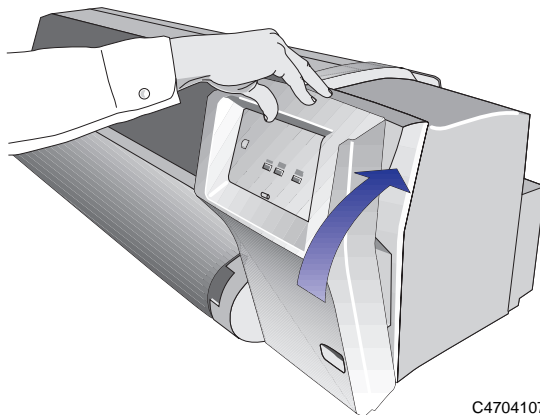

C4704107

The front panel will display the message “*Open left door to access ink cartrg.*”.

Continue with the next procedure, *Removing and Replacing the Ink Cartridges.*

# 3 Removing and Replacing the Ink Cartridges

- 1 Open the left door on the printer.

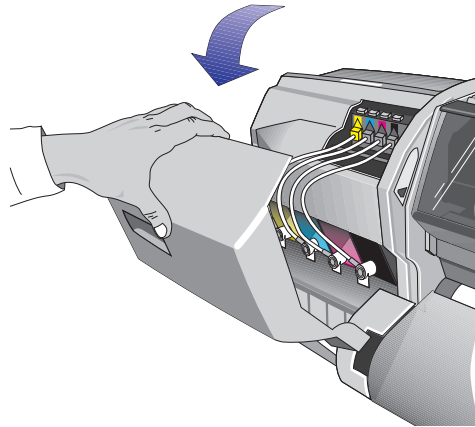

C4704108

After you open the left door, the printer displays the message shown below on the front panel. The blinking indicator shows which ink cartridge must be replaced. In the example below, the yellow ink cartridge needs to be replaced.

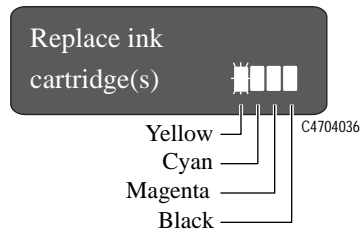

Working with Ink Systems  
Replace the Ink System

- 2 While pressing down on the quick-release button (1), unplug the ink cartridge tube by pulling the tube connector away from the printer (2).

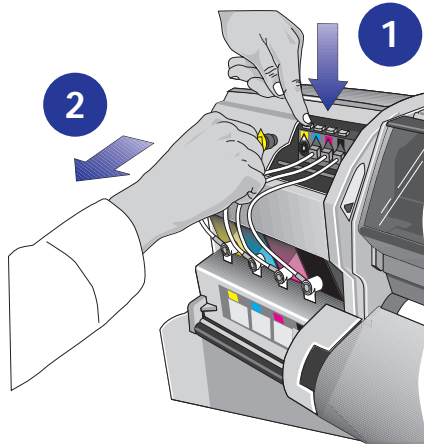

C4704113

---

**CAUTION**

---

Never pull the ink cartridge out by the tube or connector. This may cause the ink cartridge to leak. Always grasp the body of the cartridge when removing or installing.

- 3 Remove the used ink cartridge from the slot in the printer. Discard the used ink cartridge.

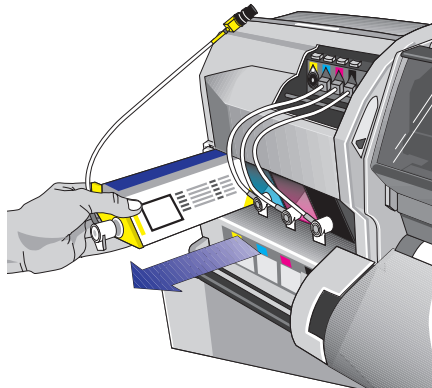

C4704143

- 4 Insert the new ink cartridge into the slot in the printer, making sure that you match the color of the ink cartridge with the color code on the printer.

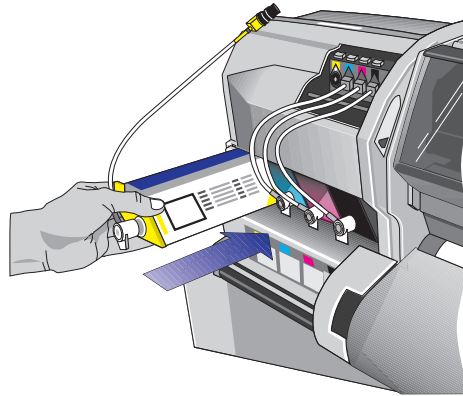

C4704142

- 5 Plug the valve on the ink cartridge tube into the connector on the printer making sure that you match the valve color with the color code on the valve connector.

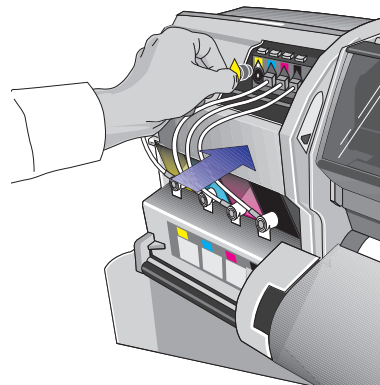

C4704134

- 6 Repeat steps 2 through 5 for any additional ink cartridges you need to replace.

When you have finished replacing ink cartridges, the printer front panel displays the message “*Close left door to continue*”.

- 7 Close the left door on the printer.

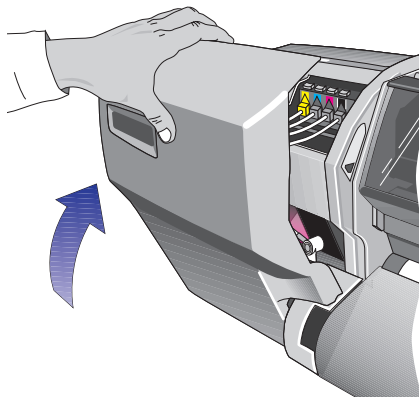

C4704103

After the left door is closed, The front panel displays the message “*STATUS, Checking ink system*” while the printer checks that all ink system components have been installed correctly. This may take a few minutes.

**Components  
Installed Correctly**

If all components have been installed correctly, the front panel displays “*Install complete*”.

**Components  
Installed Incorrectly**

If any components have been installed incorrectly, the front panel will prompt you to take the appropriate action to correct the problem. See chapter 12, *Front-Panel Messages*, for information about any messages that are displayed in the front panel.

**Next Step**

Go to *After replacing the Ink System* on the next page for information on the alignment and calibration checks performed by the printer after ink system replacement.

## After replacing the Ink System

After you replace the ink system, the printer:

- aligns the printheads
- performs a printhead check (if enabled)
- calibrates the color, if the color calibration function is enabled in the front-panel.

See chapter 9, *Controlling Image Quality*, for more information on these functions.

If no media is loaded, the printer will display the message “*Load media to align printheads.*” Load media following the directions in chapter 3, *Working with Media*. The alignment procedure requires an A2 or C-size media width. An A3 or B-size cut sheet media can only be accepted if loaded in the landscape position.

When the front panel displays “*STATUS Ready*”, you are ready to print.

**NOTE:**Make sure the printer window and the left and right doors are closed after you replace ink system components. The printer will not print while these are open.

**NOTE:**If after installing the ink systems you experience problems see page 11-31, *Solving Ink System Problems*.

## Removing and Storing Partially Used Ink Systems

If you need to print several images unattended (for example, when printing overnight) and one or more of the ink colors is low on ink, you may want to replace these colors with new ones before starting to print and store them in the HP DesignJet CP Ink System Storage Container.

If you need to change from the HP DesignJet CP Ink System (*Imaging ink*) to the HP DesignJet CP Ink System UV (*UV Pigmented ink*) or vice versa, you will need to store the printheads and printhead cleaners that you are not using. When storing Ink Systems remember:

---

**CAUTION**

---

**Do not touch the printhead nozzles.**

### Handle the Ink Systems with Care

- Always store the partially used printheads and printhead cleaners in the HP DesignJet CP Ink System Storage Container. Keep the partially used ink cartridges close by the HP DesignJet CP Ink System Storage Container. This will prevent unintentional mixing of different sets of ink system components.
- You can store the HP DesignJet CP Ink System UV (*UV Pigmented ink*) printheads and printhead cleaners in the storage container for up to six weeks without affecting the Outdoor Durability Warranty (providing you comply with the warranty procedures).
- Make sure all four ink colors that you are storing are the same type of HP Ink System. **Never mix UV Pigmented ink and Imaging ink components.**
- Always handle and store the printhead cleaners upright to avoid spilling ink.
- Handle the system with care.



## Storing the Ink System in the HP DesignJet CP Ink System Storage Container

Additional HP DesignJet CP Ink System Storage Containers can be purchased separately through your Hewlett-Packard dealer. Refer to page 13-18, *Ordering Accessories* for more information.

---

### CAUTION

---

**The sequence in which the printhead cleaner and printhead are inserted into the HP DesignJet CP Ink System Storage Container is very important to prevent printhead damage. Always follow the sequence in the procedure given below.**

- 1 To remove the partially used Ink System components from the printer refer to page 4-11, *Removing and Replacing Ink Systems*.
- 2 Have the Ink System components ready for storing in the HP DesignJet CP Ink System Storage Container.
- 3 Lower the two cover lock-arms and remove the top cover from the storage container.

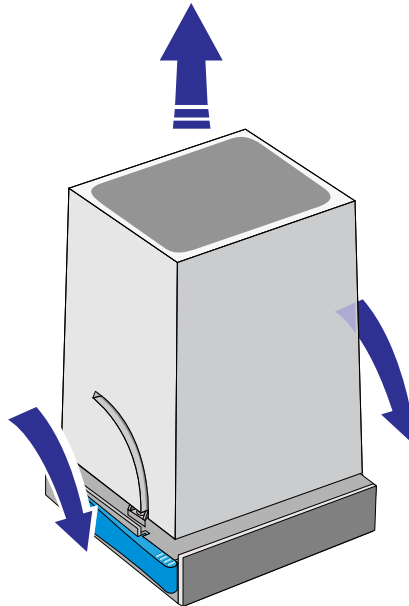

C6240007

- 4 Lift the lever arm and insert the printhead cleaner into the matching color coded slot in the HP DesignJet CP Ink System Storage Container.

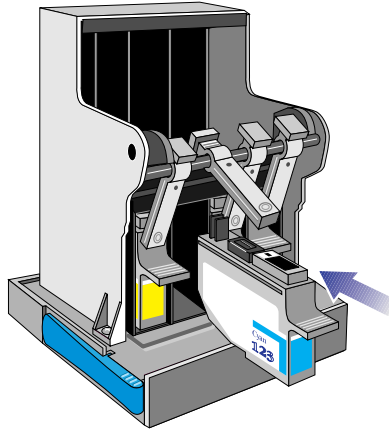

C6240001

- 5 Push the lever arm forward so that the printhead cleaner “clicks” into position in the HP DesignJet CP Ink System Storage Container.

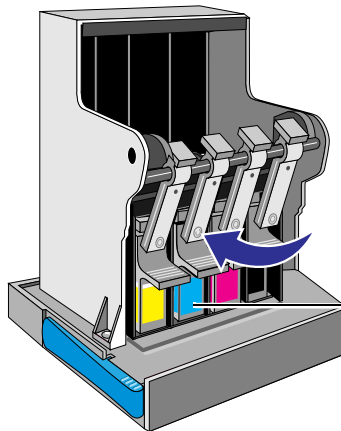

Push the lever arm until the printhead cleaner “Clicks” into place

C6240002

---

**NOTE**

The movement of the lever arm will push the printhead cleaner into the slot and then move the printhead cleaner slightly upwards so that it “clicks” into the stored position.

The lever arms also prevents installing the printheads and printhead cleaners into the HP DesignJet CP Ink System Storage Container in the wrong sequence. This will prevent inadvertent damage to the printheads.

- 6 Repeat steps 4 and 5 for the three remaining color printhead cleaners in the Ink System.

- 7 Insert the printhead into the stall with the color dot that matches the color of the printhead label.

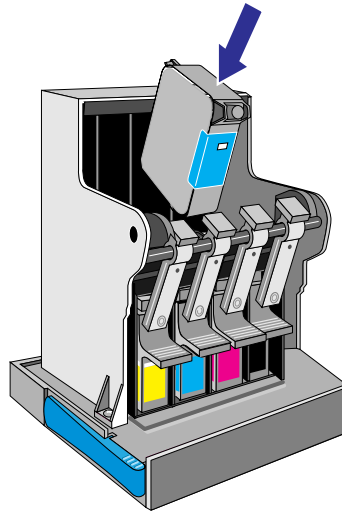

C6240003

---

**NOTE**

---

**Each printhead is color keyed to the correct stall and will not fit in any other position.**

- 8 Press down lightly and push the printhead away from you (toward the back of the cradle) until it “clicks” into place.

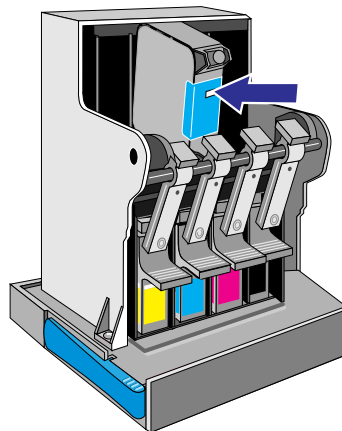

C6240004

- 9 Repeat steps 7 and 8 for the three remaining color printheads in the Ink System.
- 10 Put the top cover onto the HP DesignJet CP Ink System Storage Container and raise the two lock-arms to the locked position.

---

**NOTE**

---

**You can store the HP DesignJet CP Ink System UV (*UV Pigmented ink*) printheads and printhead cleaners in the storage container for up to six weeks without affecting the Outdoor Durability Warranty (providing you comply with the warranty procedures)**

- 11** Make sure the lock-arms are in the locked position when lifting the HP DesignJet CP Ink System Storage Container by the cover.

## Removing the Ink System from the HP DesignJet CP Ink System Storage Container

---

**CAUTION**

---

The sequence in which the printhead and printhead cleaner are removed from the HP DesignJet CP Ink System Storage Container is very important to prevent printhead damage. Always follow the sequence in the procedure given below.

- 1 Lower the two cover lock-arms and remove the top cover from the HP DesignJet CP Ink System Storage Container.

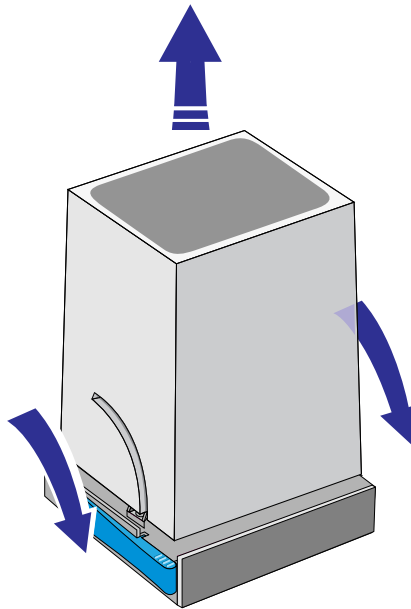

C6240007

## Working with Ink Systems

### Removing and Storing Partially Used Ink Systems

- 2 Press down lightly on the printhead and pull it toward you, removing it from the stall.

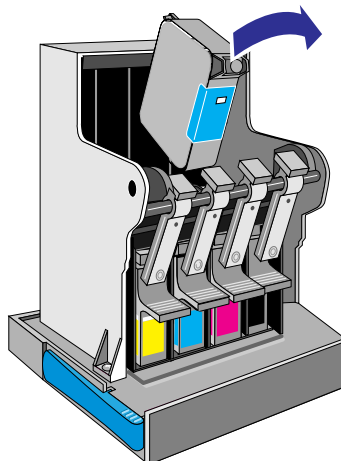

C6240006

- 3 Repeat step 2 for the three remaining color printheads in the HP DesignJet CP Ink System Storage Container.
- 4 Pull the lever arm up and towards you. Press down on the printhead cleaner handle and pull it out of the stall.

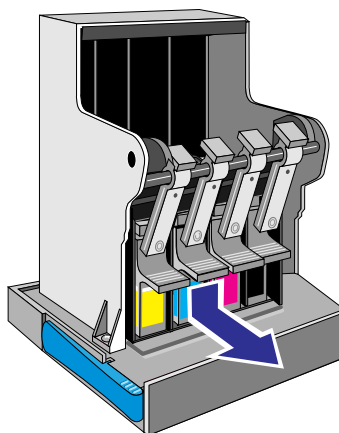

C6240005

- 5 Repeat step 4 for the three remaining color printhead cleaners in the HP DesignJet CP Ink System Storage Container.
- 6 Put the top cover onto the HP DesignJet CP Ink System Storage Container and raise the two lock-arms to the locked position.

---

# Controlling the Page Format

# 5

---

Page Format 5-2

Page Size and Accuracy 5-8

Selecting the Ink Emulation Mode 5-11

Adjusting Margins for Roll and Sheet Media 5-12

Rotating an Image 5-15

Printing a Mirror Image 5-19

Changing the Scale of a Printed Image 5-20

## Page Format

This chapter explains how to make sure that the printer produces your print in the page format you want.

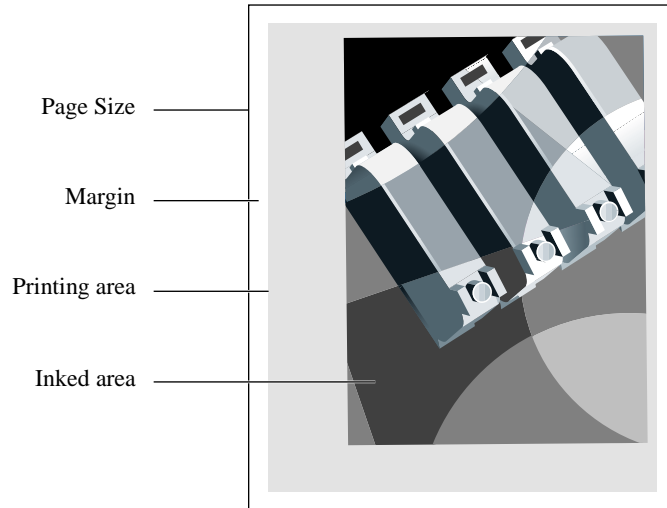

C4704042



<b>Page size</b>	Page size can be specified from the front panel or in the software, where it may be called "Page Size", "Media Size", "Paper Size" etc., and where the options include, for example, ISO A3, ANSI Letter, Custom, etc. If your software does not put a page size command in the print file, the front-panel setting is used. Otherwise, the software setting overrides the front-panel setting.
<hr/> <b>NOTE</b> <hr/>	<b>There is one exception to this rule. If the front-panel setting is Inked area and you are sending a PostScript file, the front panel setting is used. See page 5-5, <i>Adjusting the Page Size in the Front Panel</i>.</b>
<b>Margins</b>	Margins are normally 27 mm on the leading and trailing edges and 15 mm on the sides. The 27 mm can be adjusted for roll media, as explained on page 5-12, <i>Adjusting Margins for Roll and Sheet Media</i> .
<b>Printing area</b>	Printing area is the page size minus the margins. For a table showing the printing areas for standard media sizes, see page 13-9, <i>Printing Area (= Media Size Minus Margins)</i> .
<b>Inked area</b>	Inked area is the smallest rectangle that contains the entire image, while maintaining its aspect ratio (relative height and width dimensions).

## Do You Need to Adjust the Page Size in the Front Panel?

The answer is normally no, because the page size you have selected in your driver overrides the page size selected in the printer. However, some of the circumstances in which you may want to change the default setting are:

- When you are using the PS Scale→Fit to page feature. See page 5-20, *Changing the Scale of a Printed Image*.
- When you are not using one of the HP DesignJet PostScript drivers supplied with your printer; for example, if you are sending a PostScript file from a UNIX application.
- When you want to save media by printing only the inked area of your print, plus the margins. In this case set Page format / Size to Inked area.

### Non-PostScript files

Depending on the driver you are using, you may not need to change the page size in the front panel. The default Size setting (Software) in the Page Format menu causes the printer to look for the page size information in the print file: if it is there, the printer uses it.

However, some of the circumstances in which you may want to change the default setting are:

- If you want to print the inked area only, but the driver you are using does not specify “Inked area”.

In this case, set the Size setting in the Page format menu to Inked area.

If you can select Inked area from your driver, any selection you have made in the front-panel menu will be overridden by the settings in the driver.

- When the prints you are creating need to be of a specific standard (for example, ISO or ANSI), but the actual size within that standard is not important. For example, your page size may need to conform to a standard ISO page size, but it does not matter whether the final page size is ISO A4 or ISO A3.

In this case, set Page format / Size to ISO → Best... or ANSI → Best... etc. The printer uses the smallest standard size into which the inked area will fit.

## Adjusting the Page Size in the Front Panel

### PostScript files

Unless you are using the front-panel PS Scale→Fit to page option (see page 5-20, *Changing the Scale of a Printed Image*), the front-panel page-size settings have no effect on PostScript files that already contain page-size information, which includes all PostScript files sent using one of the HP DesignJet PostScript drivers supplied with this printer.

If you are using the front-panel PS Scale→Fit to page option, then the printer uses the page size set in the printer's front panel as follows:

- If the page size is set to a discrete size, it uses the specified page size.
- If the page size is set to Software, the printer calculates the page width as the width of the loaded media and the page length as 1.5 times the width of the loaded media.
- If the page size is set to Inked area, the printer calculates the page width as the width of the loaded media and the page length as the height of the inked area plus the top and bottom margins of the page.
- If the page size is set to a “Best...” option, the printer calculates the page length as 1.5 times the page width.

Page format  
Size  
All menu modes  
Default: Software

## Non-PostScript files

The Size option lets you select the page size of your print. The options are described in the following table. If you need to adjust the page size from the front panel, do so before sending the file from your computer. The printer determines the size of a print at the time it is received from your application.

Page format Size=		Comments
Inked Area		The printed page size is the inked area plus margins. For a definition of “inked area”, see page 5-3.
Software		The printer looks to the print you have sent for a page size instruction. If it is present the printer uses this. If not, the printed page size is the inked area plus margins.
ISO	Best ISO A ISO A0/A1/A2/A3/ A4	<b>“Best...” Options</b> The printer chooses the smallest page size from the corresponding discrete options that will hold the inked area of the print. For example, if <b>Best ISO A</b> is selected and the inked area of the print is between A3 and A4, the printer chooses A3 as the page size.
ANSI	Best ANSI ANSI E/D/C/B/A	
JIS	Best JIS B JIS B1/B2/B3/B4	<b>Discrete Options</b> ISO A0/1/2/3/4 ANSI E/D/C/B/A JIS B1/2/3/4 ARCH E1/E/D/C/B/A Over A1/2 The printed page size is exactly the size you specify. The largest discrete page size you can specify is E/A0.
ARCH	Best ARCH ARCH E1/E/D/C/B/ A	
Oversize	Over A1/A2 (No “Best” option)	

## Page Size and Clipped Images

If you specify in your software a page size that is larger than the media size loaded in the printer, the printer will still print what it can, but may clip your image.

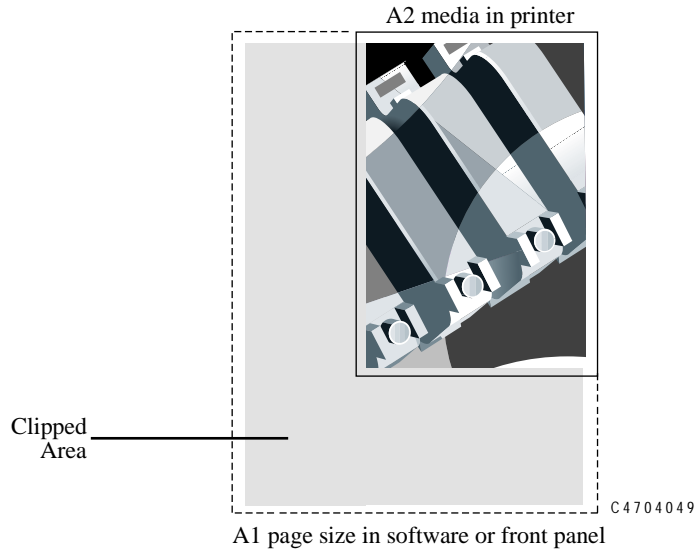

## Page Size and Nesting (Roll Media Only)

Nesting means placing two or more pages side-by-side on a roll to save media. There are certain cases when your prints can not be nested. For a complete explanation of nesting, see page 7-11, *Avoiding Media Waste by Nesting Pages*.

If you have queuing and nesting switched on, the printer will use the page size to determine which pages are nested and whether the pages can be automatically rotated when nesting. See page 7-12, *Automatic Rotation*, for information about which pages can be automatically rotated.

## Page Size and Accuracy

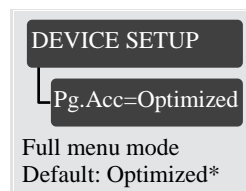

The printer dynamically modifies the advance of the media, to achieve the best image print, depending on the printheads installed in the printer and the content of the image, although the width of the image will always be correct. In the front panel display the “Page accuracy” option lets you choose one of three options.

Accuracy* Selection	Page Length Optimized	Image Quality Optimized
“Optimized”	No	Yes
“Constant”	No	No
“Maximum”	Yes	No

\* Also refer to the explanation given below and Accuracy (Maximum accumulated error) on page 13-3, *Accuracy selection*.

- 1 From the front panel, scroll through the menus and choose “Device setup”. Press **Enter** to access this menu. If you are unable to find this menu make sure that the Full Menu Mode is enabled, see page 2-16, *Selecting the Full Menu Mode*.



- 2 Once you are selected “Device setup” scroll through the menu until you find “Page Accuracy”. Press **Enter** to access this menu.



- 3 You will now have three different options. The default setting is “Optimized”.



The “Optimized” option means the printer will calculate the media advance dynamically depending on:

- the printheads
- the use of each printhead

This selection will give best possible print quality, but page lengths may change between two or more different illustrations with the same specific dimensions.

**NOTE:**Select “Optimized” when page size accuracy is not critical and you want the best possible print quality.

If the print quality of your images is not the most important factor, you can change the page accuracy setting as follows:

- 4 With the “Page Accuracy” menu still selected, scroll through the menu until “Constant” is displayed. Press **Enter** to access this menu.



C4704034

By selecting this option, a constant media-advance correction will be automatically applied, depending on the printhead set present, but not on each color being used. This media-advance correction will remain constant throughout the life of the printhead set. With this mode you may notice slight image quality degradation when compared to the previous option “Optimized”.

**NOTE:**Select “Constant” when page size accuracy is an important factor and good image quality is still necessary; for example when tiling images or producing transparent media overlays.

## Controlling the Page Format Page Size and Accuracy

- 5 With the “Page Accuracy” menu still selected, scroll through the menu until “Maximum” is displayed. Press **Enter** to access this menu.



C4704034

By selecting this option, the printer will advance media without any dependence on the printhead. Choose this option to achieve the maximum page-size accuracy. Image quality may be worse than the two previous options.

**NOTE:**“Maximum” should only be selected when printing line artwork where end-point accuracy is the most important factor or for posters which must match an exact predefined size.

### **Page Size Using the HP DesignJet CP UV Ink System**

When printing using UV inks on a roll, the page size is also affected by the increased leading edge margin (*described above*). Consequently whatever page size you have selected, it will be increased by an additional 27.0mm (1.06 inch) on the leading edge.



## Selecting the Ink Emulation Mode

### DEVICE SETUP

#### Ink emul.=

All menu mode  
Default: EuroScale

Your printer can emulate the color behavior of offset printing presses, allowing you to use your printer for color proofing. To get accurate colors for your proof, select the color emulation mode that matches your offset printing standards. The selections are:

- Native - No ink emulation, uses HP DesignJet CP CMYK Ink settings.
- SWOP - U.S. Specification for Web Offset Printing.
- TOYO - Japan standard for offset press.
- EuroScale- European standard for offset press.
- Enhanced - Optimized version of “Native”.

The Enhanced Native mode is an optimized version of the Native mode color values will printed without adjustment unless they are likely to cause printing problems, in which case they will be adjusted to safer values.

Enhanced Native mode gives the biggest color gamut without compromising print quality.

The enhanced Native mode applies ink limitations (200%) to control ink volume and minimize cockle and gloss unevenness (caused by too much ink on the media). It does not apply any color mapping.

---

### CAUTION

**If your application generates CMYK color values and you select Native ink emulation (no color adjustment), the printer may apply an excessive amount of ink which may affect image quality on some types of media. In extreme cases (more than 200% ink density) coated paper may become saturated, resulting in serious printhead damage.**

---

## Adjusting Margins for Roll and Sheet Media

Page format

Margins

Full menu mode  
Default: Extended  
Affects next file

Besides nesting and setting the page size, you can also change the margin settings and expand the printing area of the page, reducing the amount of media waste. The two side margins are 15.0 mm. The default margin settings for the leading and trailing edges of the media vary, depending whether you are using roll or sheet media, as shown in the illustrations below:

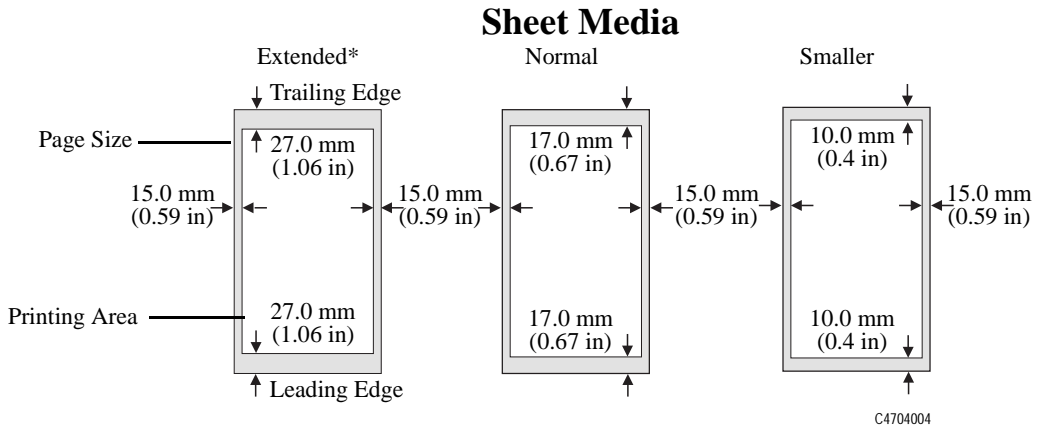
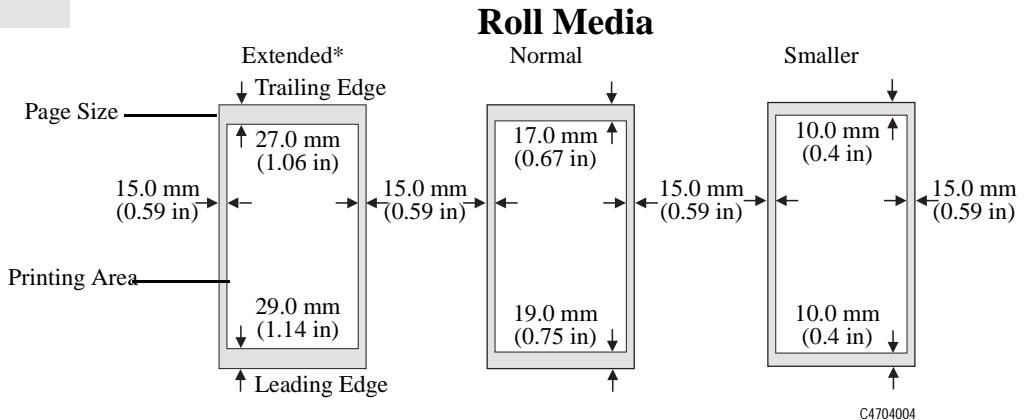

Extended margins provide wider top and bottom margins. Extended margins enable the printer to do automatic error correction on the leading and trailing edges of an image to prevent image quality defects when it detects nonfunctional nozzles. See page 9-6, *Checking Printheads*, for more information on this feature.

---

**NOTE**

---

**If you select Smaller Margins with PostScript files, the printer uses the Normal margin settings. The HP PostScript printer drivers provided with your printer use Extended margins only. The setting in your driver override settings in the front panel.**

**Non-PostScript Files Only** For roll media if you select Smaller in the Margins menu selection, you can reduce the margins to 10 mm on the leading and trailing edges of the media.

---

**NOTE** If Smaller margins are selected, the Nesting auto-rotation feature is disabled. Pages will not be automatically rotated.

---

**Non-PostScript Files Only** **Margins and Automatic Cutting**

When the Margins setting is set to Smaller, the printer waits for the print to dry and the next file to begin printing before cutting the page from the roll. If you press **Form Feed and Cut**, the printer immediately cuts off the current page. When the next file begins, the printer cuts the media again to give this page the narrow margin.

### **Print Margins using the HP DesignJet CP UV Ink System**

When printing with UV inks with extended or normal margins selected, the leading edge margin will increase by 27.0mm (1.06 inch). The total leading edge margin for UV Opaque vinyl selection on roll media will be:

<b>Margin Selection</b>	<b>Leading Edge Margin Dimension</b>
<b>Normal</b>	46.0mm (1.81 inches)
<b>Extended</b>	56.0mm (2.20 inches)

## Rotating an Image

Your images can be rotated from the Page format / Rotate option in the front panel if:

- The file is an RTL/HP-GL/2 file and Queueing and Nesting are off (see page 7-11, *Avoiding Media Waste by Nesting Pages*)
- The file is a PostScript file (HP DesignJet 2500CP only)
- The file is an RTL/HP-GL/2 file and the file contains no raster data.

### Rotating an Image from the Front Panel

Except in the circumstances stated above, you can rotate a drawing from the printer's front panel, without changing the drawing in your software. The options are 0, 90, 180 or 270 degrees relative to the drawing's orientation in your software. The rotation is counterclockwise, as shown below.

Page format

Rotate

All menu modes  
Default: 0

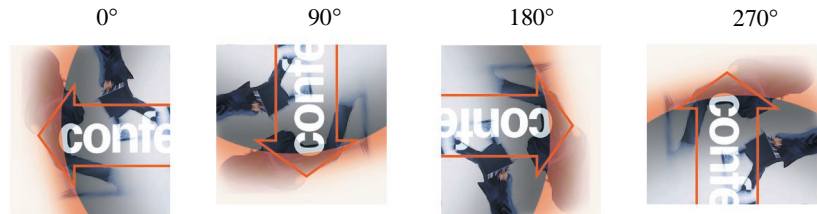

C4704047

## What is Rotated?

- ◆ With roll media, both the drawing and the page orientation are rotated.

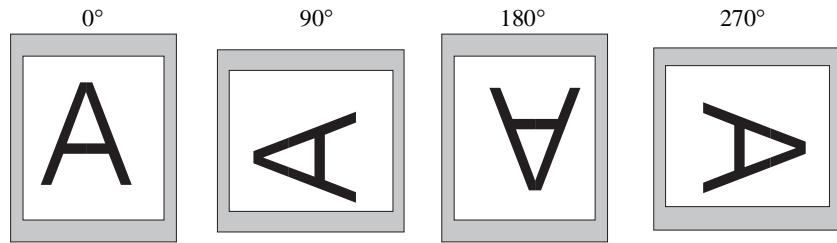

C4704043

Notice that the narrow margins are always at the left and right sides, regardless of the orientation. The page size is adjusted to maintain the printing area, preventing clipping.

- ◆ With sheet media, the drawing is rotated, but the page orientation specified in your software is retained. (You should always load sheet media in the orientation you have specified in the software.)

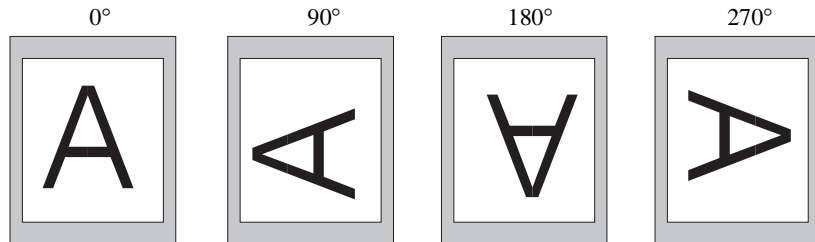

C4704044

The front panel's Rotate setting has no effect on PostScript files printed on sheet media. Use the settings in the PostScript driver to select rotation.

## How Does Rotate Interact with Your Software?

### For PostScript files

- On sheet media, the front-panel Rotate setting has no effect.
- On roll media, use the front-panel Rotate setting to save media, by printing narrow pages in landscape orientation, that is, with the short edge parallel to the media path. As an example, when rotated by  $90^\circ$  or  $270^\circ$ , the page size is enlarged by  $2 \times (27-15) = 24$  mm, i.e.,

$$[\text{leading and trailing edges}] - [\text{side margins}] = 24 \text{ mm}$$

This prevents the larger margins resulting from the rotation from encroaching on the image.

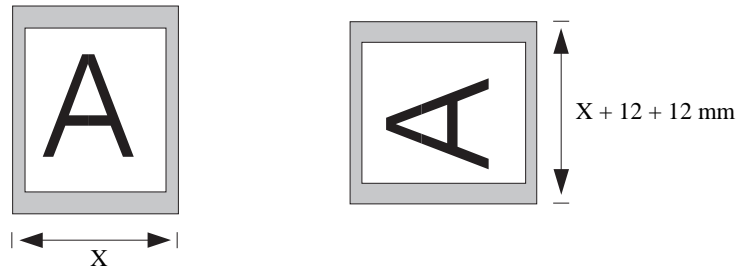

C4704050

- The rotate setting in your printer driver overrides the rotate setting in the front panel.

### **For Non-PostScript Files**

- The printer adds the rotation setting to any rotation angle you specify in your software. For example:

For software applications which, like the printer, rotate counter-clockwise the result is the sum of the rotation selected in the printer and the rotation selected in the software application. For example, if your software specifies 180 degrees rotation, and you set Rotate in the front panel to 90, your drawing's final rotation will be 270 degrees.

For software applications which rotate clockwise, the result is the difference between the rotation selected in the printer and the rotation selected in the software application. For example, if your software specifies 90 degrees rotation, and you set Rotate in the front panel to 90, there will be no rotation.

- *Possibility of Clipped Images with Rotated Images*

With either roll or sheet media, if you rotate an image to landscape whose original orientation was portrait, the media may not be wide enough for the drawing, and it may be clipped. For example, rotating a portrait D/A1-size image on D/A1-size media by 90 degrees will probably result in a clipped image.



## Printing a Mirror Image

If you are using clear imaging media, sometimes called backlit. You may want to print a mirror image of your plot. So that when the media is lit from behind it is in the correct orientation. This can be done from the front panel, without changing the image in your software.

Page format

Mirroring

Full menu mode  
Default: Off  
Affects current print  
Resets after power off

Mirror Off



Mirror On



C4704051

---

### NOTE

**Do not change the setting during a print, because the change becomes effective immediately. If you change the setting in the middle of the current print, the remaining data is printed in the mirrored orientation.**

---

## Changing the Scale of a Printed Image

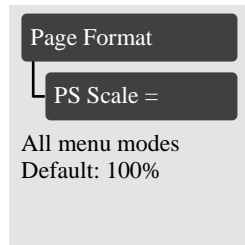

With a PostScript file, you can enlarge your printed image from the printer's front panel by using the PS scale option, accessed from the Page format menu.

The PS scale feature is useful:

- If your software does not support large formats.
- If your file is too large for the printer's memory, and you reduce the page size in your software and then scale it up again using the front-panel option.

### To scale your ANSI A PostScript file to:

	ANSI B	ANSI C	Arch C	ANSI D	Arch D	Arch E1	ANSI E	Arch E
<b>Use...</b>	129%	200%	210%	258%	282%	352%	400%	419%

### To scale your ISO A4 PostScript file to:

	ISO A3	ISO/JIS A2	OS A2	ISO/JIS A1	OS A1	ISO/JIS A0
<b>Use...</b>	129%	200%	210%	258%	352%	400%

- Fit To Page** The Fit to page setting adjusts the image size to the page size selected for your printer. For example, If you have selected ISO A2 as the page size and you print an A4-size image, it will be enlarged to fit the A2 page. If ISO A4 page size is selected, the printer would reduce a larger image to fit the A4 size.
- Cumulative Scaling Factors** The PostScript scaling factors are cumulative with software settings. For example, if you select 200% scaling in your software and 210% scaling in the front-panel PS Scale menu, the printed image would be scaled 420%. Whatever scale you choose will be used for PostScript files until you choose another scale, even if you change the graphics language from PostScript and back again.

Controlling the Page Format  
Changing the Scale of a Printed Image

---

# Controlling the Overall appearance of a Print

# 6

---

Ways of Controlling the Print's Appearance 6-2

Changing Pen Widths and Colors Using the Internal Palettes 6-3

Changing the Treatment of Overlapping Lines (Merge) 6-9

Printing Color Images in Monochrome 6-10

Printing Speeds and Print Quality 6-12

## Ways of Controlling the Print's Appearance

**NOTE:**Unless you have specifically indicated in your software that the printer's front-panel settings are to be used (for example, Printer's default Setting in a Macintosh Print Options window), the software settings for a PostScript file override the printer front-panel settings described in this chapter.

This chapter discusses the ways you can control the overall appearance of your prints from the front panel in terms of:

- pen width
- pen color
- treatment of overlapping lines
- overall lightness/darkness
- rendering color drawings in monochrome
- overall print quality and resolution.

Some front-panel selections affect the next file you send from your computer, not pages already in the printer's queue. If this is the case, it is stated in the relevant part of this chapter.

Some of the controls are available using the front-panel menus (for example) pen width, pen color, overlapping lines). Print quality and color/monochrome print options are controlled from the front-panel keys.

### **Why Change the Appearance of the Print Using the Front Panel?**

By default, the printer looks to your software to provide information on all the above attributes. However, your driver or application may not provide these controls or you may want to experiment with various effects, or try a temporary change, without the need to change your drawing or your driver settings.

## Changing Pen Widths and Colors Using the Internal Palettes

The “pens” discussed throughout this chapter are the “conceptual” pens in a software palette, rather than the printer's physical printheads.

These settings have no effect on PostScript files.

**The printer has three pen palettes:**

- Factory
- Palette A
- Palette B.

The factory palette cannot be changed. You can, however, change the line width and color settings for each pen in the remaining two palettes (palette A and palette B). Initially, all three palettes are identical. Each palette has 16 pens which can include pens of different widths and any combination of the printer's predefined 256 colors.

## To Select a Palette

To select a palette through the front-panel menu, go to the Define Palette selection under HP-GL/2 SETTINGS and choose the palette you want.

The following table describes the palette choices.

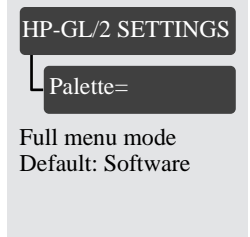

The screenshot shows a menu with the following text: HP-GL/2 SETTINGS, Palette=, Full menu mode, and Default: Software. A line connects the 'Palette=' option to the 'Palette' column of the table below.

Palette	Comments
Software	The printer looks to your software for pen settings and ignores all three internal palettes.
Palette A	The printer assigns the attributes defined in Palette A to the pens defined in your software as 0 through 15.
Palette B	The printer assigns the attributes defined in Palette B to the pens defined in your software as 0 through 15.
Factory	The printer assigns the attributes defined in the Factory Palette to the pens defined in your software as 0 through 15.

**NOTE:** These settings have no effect on PostScript files



## Viewing Current Config. Settings

- 1 Make sure either a roll or a sheet of media is loaded.
- 2 Make sure that the front-panel **Color/Mono** switch is set to *Color*.
- 3 Print the Current Configuration Print, by pressing the **↑** and **↓** keys simultaneously.

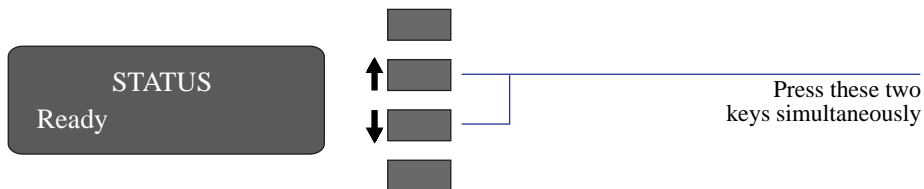

C4704000

Notice on the Current Configuration Print that the 16 pens are numbered 0 through 15 and the 256 colors are numbered 0 through 255. These colors are specified in the Palette Print, as explained in the following sections.

**NOTE:** These settings have no effect on PostScript files.

## Viewing the Colors Available For a Palette

- 1 Make sure that the front-panel **Color/Mono** switch is set to **Color**.
- 2 To print the Palette, go to the INTERNAL PRINTS menu and choose HP-GL/2 Palette.

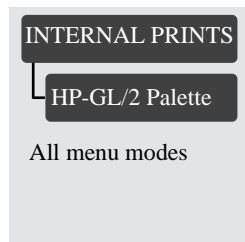

In the Palette print, there are 256 squares, numbered 0 through 255, each showing one of the 256 colors available for selection in the printer's internal palettes. The example below is color 6 (magenta), which is assigned to pen 6 in the factory's default palette.

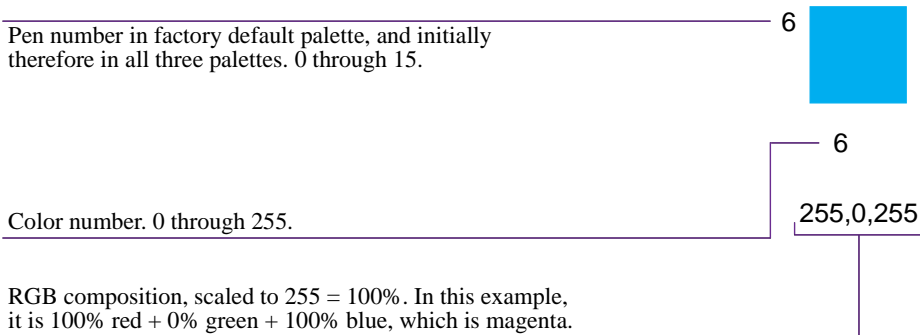

C4704021

Note that RGB and CMYK - plus white - are assigned by default to pens 0 through 7, and that eight greyscales are included in the 256 colors.

The 256 colors shown in the Palette Print are not the only colors you can print with your printer! Using your software, you can create many more colors and, as long as you are using the correct driver, the printer will reproduce these colors by an appropriate mix of inks from its CMYK cartridges. The Palette Print merely shows the 256 colors available for use in the printer's internal palettes, should you choose to use them.

## To Change the Palette Settings

You cannot change the Factory palette, but you can define Palettes A and B to be whatever you choose.

Item	Available Options
Palettes	Factory, A, B.
Pens	0 through 15.
Widths (mm)	0.13, 0.18, 0.25, 0.35, 0.50, 0.65, 0.70, 0.80, 0.90, 1.00, 1.40, 2.00, 3.00, 5.00, 8.00, 12.00. Note that 0.13 mm is a one-pixel line width at 300 dpi and three-pixels line width at 600 dpi: some colors are rendered as a dot pattern.
Colors	0 through 255. As specified on the Palette Print.

**NOTE:** These settings have no effect on PostScript files.

The following steps explain how to define Palette A.

- 1 In the front-panel menu, go to the Define Palette selection and choose Palette A.
  - 2 Scroll to the pen number you want to change and press **Enter**.
  - 3 The current width assigned to this pen is displayed, for example Width=0.35mm. If you want to change it:
    - a Press **Enter**.
    - b Scroll to the width you want
    - c Then press **Enter** again.
- Otherwise, scroll to Color.
- 4 The current color assigned to the pen is displayed, for example Color=110. If you want to change it:
    - a Press **Enter**.
    - b Scroll to the color you want.
    - c Then press **Enter** again.
  - 5 When both width and color are correct, press **Previous**.

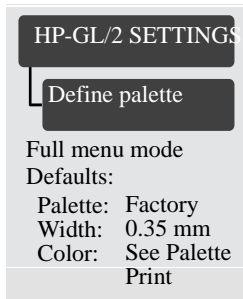

Controlling the Overall appearance of a Print  
Changing Pen Widths and Colors Using the Internal Palettes

- 6 Scroll to the next pen number you want to change, press **Enter** and do steps 3 through 5 again.
- 7 When all pen definitions are correct, press **Previous** until you exit the menus.

**IMPORTANT**

**The palette you have just defined will take effect only when you select it to be the current palette, as explained on page 6-4, *To Select a Palette*.**

## Changing the Treatment of Overlapping Lines (Merge)

HP-GL/2 Settings

Merge

Full menu mode  
Default: Off

The Merge setting controls how overlapping lines are treated. Merge has two settings, Off and On. The following illustration shows the effect of each setting.

### Merge off.

A subsequent line hides a previous line where they overlap.

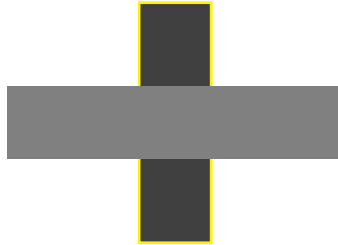

### Merge on.

Overlapping lines and area fills are merged.

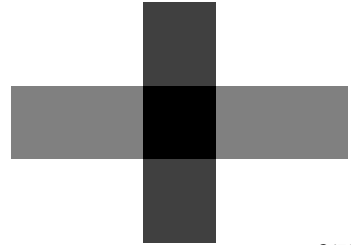

C4704022

You can set the merge setting from your software in some applications. Settings in your software override the front-panel settings.

**NOTE:** Merge settings have no effect on PostScript files.

## Printing Color Images in Monochrome

There are times when you may want to print a color image in monochrome (grayscale only). Examples of this are:

- You want a draft where color is not important, for example to check that the image is not going to be clipped,
- You want a version for photocopying in black and white.

*Remember the following important points:*

- Monochrome printing renders colors as grayscales rather than all colors as black. If you want all colors to be printed as black, then you should set all your colors to black in your software. For example, if supported in your software, use a pen number that is 100% black.

Alternatively, you could make one of the printer's internal palettes (A or B) all black, and then select this as the current palette (see page 6-3 in this chapter for an explanation of palettes).

**NOTE:** The Palette Settings do not affect PostScript files.

- You cannot change the color/monochrome setting for pages already in the printer's queue.

---

### NOTE

**Printing a color image in grayscale may affect print quality. For best results, select grayscale in your application software and, in the printer driver and front panel, select color. This usually provides the best quality image.**

---

## Switching between Color and Monochrome

- 1 Use the front-panel key shown below to toggle between color and monochrome.

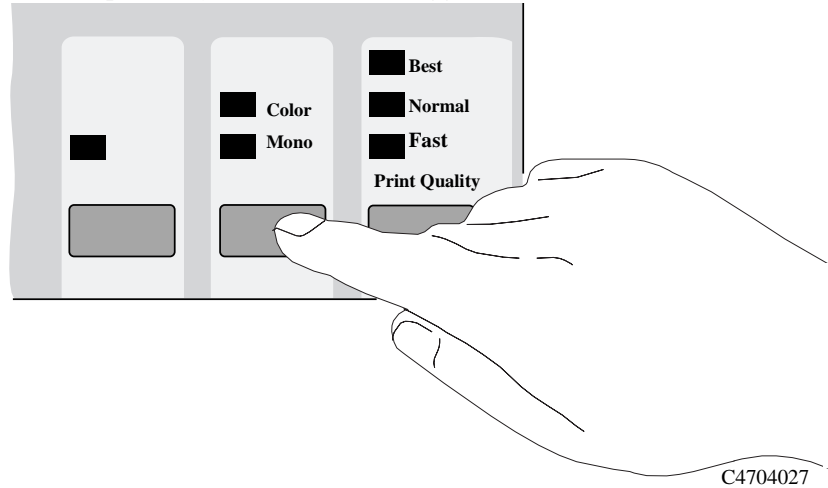

- 2 Send the file from your computer.

---













### NOTE

**The Color/Mono setting also effects most of the printer's internal prints. The Image Quality print is always printed in color, even when Mono is selected in the front panel.**

---

## Printing Speeds and Print Quality

The printing time varies with the Print quality setting, and with the media type specified. Recommended combinations of Print quality and media types are given on page 3-10, *Combinations of Media Type and Print Quality*. The table below shows the effects of combinations of Print quality and media type on print speed and the amount of ink used when printing an image.













Print Quality	Coted Media		Glossy, *Backlit, and Vinyl Media	
	Printing Time	Ink Used	Printing Time	Ink Used
Fast				
Normal				
Best				

**NOTE:**\*Printing on Backlit media takes the same time as Glossy or Vinyl media. However it uses twice as much ink.



## Controlling the Overall appearance of a Print Printing Speeds and Print Quality

The table below shows the different print speeds and the amount of ink used when printing an image using the six different media settings. This is representative of an E size print in **Best** mode with 20% ink density in all four colors. The printing process used by the printer varies not only with the print quality setting, but also with the media type specified. Similarly, the printing time depends on the type of image and the size of media being printed. For example, an Esize print will use more ink and take longer to print than the same print on D size media. Therefore, the table below compares the same print on the same size media.

Media	Printing Time	Ink Used
UV Opaque vinyl		
Heavyweight coated		
UV Custom media A		
UV Custom media B		
UV Custom media C		
UV Custom media D		

## Print quality settings

You can set the overall Print quality from the front panel. In general:

- Choose Fast to print your images in the shortest time.
- Choose Normal to get a good combination of image quality and Normal.
- Choose Best to get the highest possible quality.

You should print images in different modes to see which mode gives the best combination of throughput and quality for your application.

The resolution at which your print will be printed is summarized in the table below.

Print quality	Resolution in dpi	
	Monochrome	Color
Fast	300 x 300	300 x 300
Normal	300 x 300	300 x 300
Best	600 x 600	600 x 600

**Note:** If you send an RTL file processed as 600 dpi to the printer in Normal or Fast mode, it will be printed in Normal or Fast mode, but with a resolution of 600 dpi. Fast and Normal print modes are identical for Backlit media.

## Using Coated Paper and Heavy Coated Paper with Normal Mode

You should always select the media type in the front-panel menu that matches the media type you have loaded in the printer, **with one exception:**

- If you are loading Coated paper or Heavy coated paper, and you intend to print in Normal mode, you can select either **Coated paper** or **Heavy coated paper** in the front-panel menu selection.
  - For Faster Printing  
Select Normal print mode with Coated paper media type in the front panel for faster printing. This mode is not recommended for images containing gradient fills.
  - For Better Print Quality  
Select Normal print mode with Heavy coated paper media type in the front panel for better print quality.

---

### NOTE

---

**In most cases, settings in your application software or printer driver override any settings you make on the front panel of the printer.**

## Changing the print quality

---

### 2500CP Only

Use the front-panel Print Quality key to toggle between the three print quality settings. Settings in your PostScript printer driver override the front-panel setting. Use your driver for setting the print quality of images sent from your computer. Use the front panel to set the print quality for internal prints.

---

### 2000CP Only

Use the front-panel print quality key to toggle between the three print quality settings. If your software raster imaging processor (RIP) system has print quality settings, select your print quality from the RIP. It should override the front-panel settings.

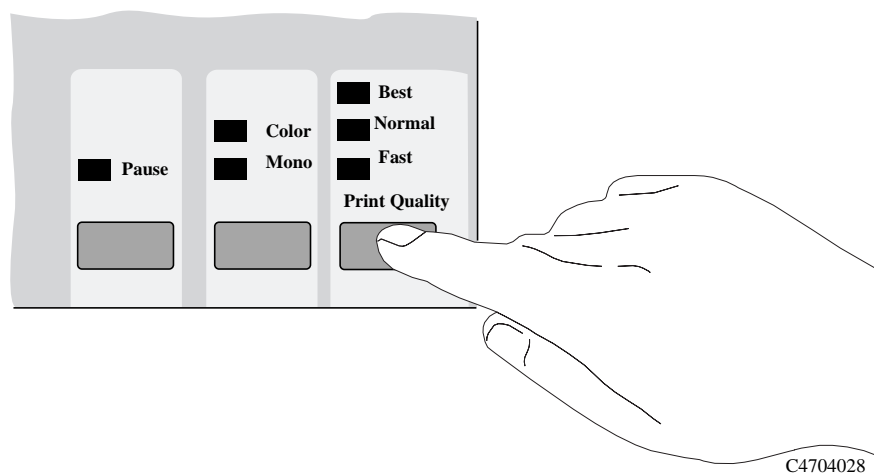

See page 3-10, *Combinations of Media Type and Print Quality* and page 3-11, *Using Coated Paper and Heavy Coated Paper with Normal Mode*, for more information about appropriate combinations of media type and print quality.

---

### NOTE

**You cannot change the print quality setting for pages being received or already in the printer's internal queue (memory).**

---

---

# Managing Your Prints

# 7

---

Managing Pages Currently being Printed or Drying 7-2

Managing Pages not yet Printed (the Queue) 7-5

Avoiding Media Waste by Nesting Pages 7-11

Getting the Best from Nesting (Nesting and Margins) 7-16

## Managing Pages Currently being Printed or Drying

---

### NOTE

In this chapter, the terms **job** and **page** are used interchangeably for files. PostScript jobs may have multiple pages. RTL and HP-GL/2 jobs are single page jobs. Where we talk about the print media, the term **page** means a single output page.

---

### Cancelling a Page



Press **Cancel** on the front panel.

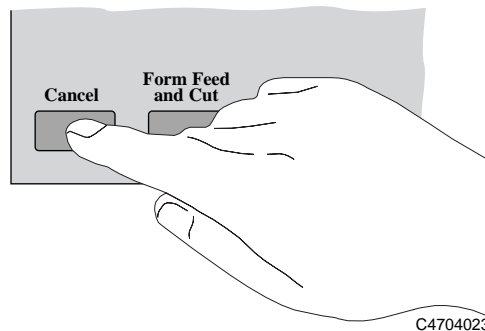

The printer advances the media as though the print were finished. A multi-page or complex PostScript file may take longer to stop printing than other files.

## Cutting a Page before Drying is Complete (Roll Media Only)

- ◆ Press **Form Feed and Cut** on the front panel.

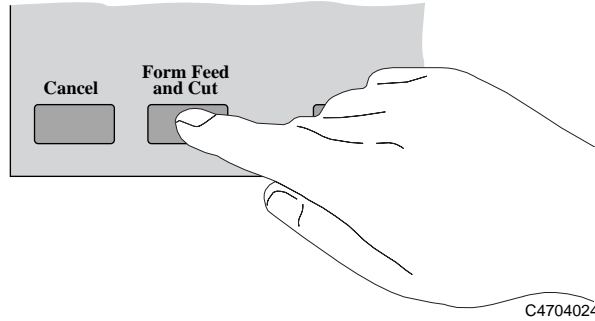

The printer ignores the drying time and immediately drops the page.

However if you have the Take Up Reel accessory installed and have it turn on, the Front Panel displays:

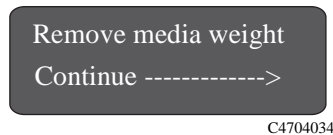

Remove the media weight and press the ↓ to continue. The front panel displays:

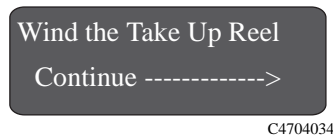

Press the wind button on the Take Up Reel and press the ↓ to continue. The printer cuts the media.

---

### WARNING

---

**If you press the Form feed and cut button while using the Take up reel, ensure you follow correctly the unloading procedure first, otherwise the printed media will fall on the floor. See page 3-26, *Unloading Media from the Take Up Reel accessory*.**

## Pausing while Printing a Series of Pages

You can pause between two pages already sent from your computer, for example to change the media type or replace the cartridges.

- 1 Press **Pause** on the front panel.

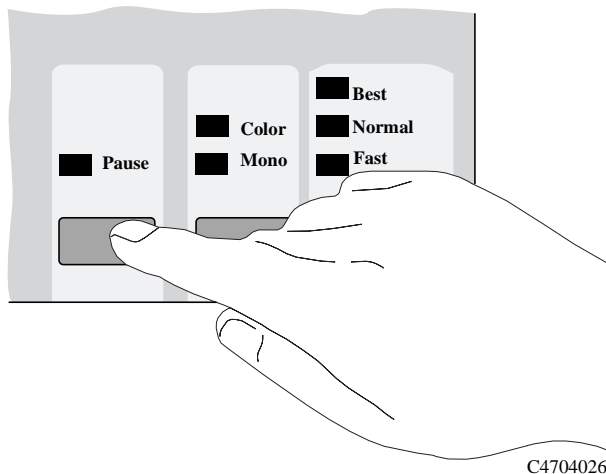

The printer finishes the current page and leaves the printer paused (indicated by the **Pause** light being on) until you press **Pause** again.

While the printer is paused, you can use the front-panel as normal, for example to change a front-panel menu setting or to load and specify a new media type.

- 2 To resume printing, press **Pause** again.

---

### NOTE

---

**If the printer is paused and you make changes in the front panel, the changes do not affect files already in the queue.**



# Managing Pages not yet Printed (the Queue)

## What is the Queue?

Your printer can store files in a queue at the same time as printing the current file. It stores them by page. If you send only single-page files, you can regard these as files.

The size of the queue is limited by number of jobs (maximum of 32 jobs containing up to 64 pages total) and the total memory available. The queue stores processed output pages, not the input jobs. Remember that file size and memory usage are not the same thing, as explained on page 11-52, *File Size and Memory Usage*.

---

### NOTE

**If you send a very complex PostScript job with queueing turned off, the printer may stop during printing of the image while it is processing the job. This may result in a image quality defect. To avoid this, always print very complex files with queueing turned on.**

### With queueing turned ON

---

### NOTE

When Queueing is On and the printer receives print files, the files are stored in the queue in the order they are received. If Nesting is Off, the files are printed as soon as possible, in the order they are received. If Nesting is On, files are printed when the time-out period expires or there are enough files to fill a page width. **Merge settings have no effect on PostScript files.**

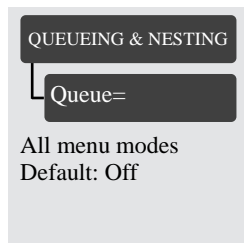

- You can resend files which have already printed.
- You can send pages to the printer without waiting for the current page to finish printing.
- Pages are stored in the queue in the order they are received.
- You can manipulate the pages in the queue, for example prioritizing them and reprinting them.
- You can use nesting, the printer's media-saving feature (see page 7-11, *Avoiding Media Waste by Nesting Pages*).
- While one page is printing, the printer will accept and process the next file

### **With queueing turned OFF**

If Queueing is Off and the printer receives print files, the files are printed as they are received, and are not stored in the queue. Nesting time-out settings have no effect when Queueing is Off.

- Files are printed as they are received, and are not stored in the queue.
- The printer will not accept another file sent from the computer until the current page has finished printing and the printer is ready.
- You cannot use nesting.

If you turn queueing off while pages are still in the queue, they will be printed and (if nesting is on) nested, until the queue is empty.

---

#### **NOTE**

---

**If the printer is turned off with unprinted files in the queue, the files are lost and must be resent.**

## Starting to Print a File that is Waiting for a Time-out

If all is in order (media loaded, ink system installed, and no file errors), there are still two reasons why a file you have sent from your computer may not start printing when expected:

- The print file may lack a proper file terminator and the printer is therefore waiting for the specified I/O time-out period before assuming it is complete. See page 8-10, *To Change the I/O Time-out Setting*.
- Nesting may be on and the printer is waiting for the specified nest wait time-out period before calculating the appropriate nests. In this case, the printer display shows the remaining time for the nesting time-out. See page 7-15, *How Long does the Printer Wait for Another File?*

In either case, if you want to override the time-out period and start printing:

- ◆ Press **Form Feed and Cut** on the front panel.

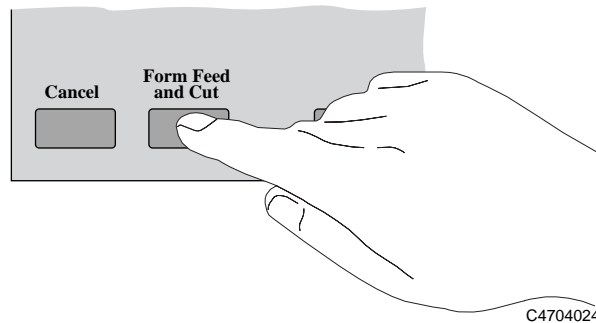

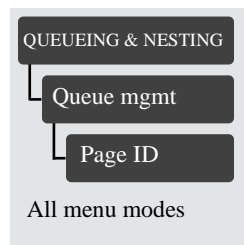

## Identifying a Job in the Queue

In Queueing / Nesting, you can scroll through the pages in the queue.

Each has an identifier, comprising:

<position in queue>: <image name>

### Position in Queue

The job currently being printed is in position 0. The next job to be printed is in position 1, the one after in position 2, etc. The previous job printed is in position -1, the one before that in position -2, etc.

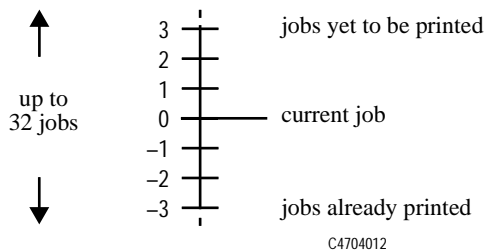

## Viewing the Size of a Page in the Queue (Non-PostScript)

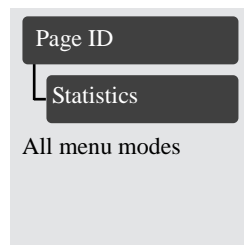

To view the size of any page in the queue, select it and choose Statistics.

Statistic	Comments
Width	The shorter side of the page, in millimeters.
Length	The longer side of the page, in millimeters.

## Prioritizing a Job in the Queue

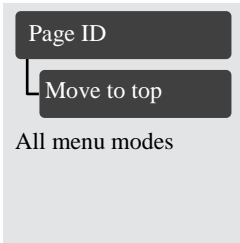

To make any job in the queue the next one to be printed, select it and choose Move to top.

If nesting is turned on (see page 7-11, *What is Nesting?*) the prioritized job may still be nested with others. If you really want this job to be printed next and on its own on the roll, then first turn nesting off and then use Move to top to move it the top of the queue.

## Deleting a Job from the Queue

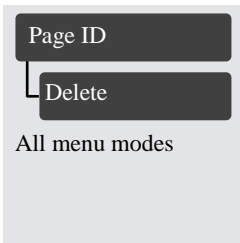

Under normal circumstances, there is no need to delete a job from the queue after printing it, as it will just “fall off the end” of the queue as more files are sent. However, if you have sent a file in error and want to avoid any chance of it being reprinted, you can simply delete it, by selecting it and choosing Delete.

To remove a job that has not yet been printed, simply identify it by its position in the queue (see page 7-8, *Position in Queue*) and delete it, by choosing Delete.

If the job is currently being printed (its queue position is 0), and you want both to cancel the job and to delete it, first press the **Cancel key** and then delete it from the queue.

## Making Copies of a Job in the Queue

Has the job already been printed?	Do you want one copy or several?	What to do
Yes	One	Use Move to top (see page 7-9, <i>Prioritizing a Job in the Queue</i> ).
	Several	Use Copies (see below) and then use Move to top (see page 7-9, <i>Prioritizing a Job in the Queue</i> ).
No	One	Use Copies (see below).
	Several	Use Copies (see below)

In all cases, the job must be still in the queue.

Page ID

Copies

All menu modes  
Default: 1

Having selected the job and chosen Copies, use the scrolling keys to specify the number of copies required, and press **Enter**. The number you enter is the actual number of pages to be printed; for example, choosing 2 for a page not yet printed means you will get the one original and one copy. The maximum is 99.

The setting you specify in this option overrides any value set by your software.

Note that, if Rotate (see page 5-15, *Rotating an Image*) was on when you sent the file, every copy will be rotated also.

# Avoiding Media Waste by Nesting Pages

**NOTE** Nesting can only be used with roll media.

## What is Nesting?

Nesting means placing pages side-by-side on the media (rather than one after the other), to avoid wasting media.

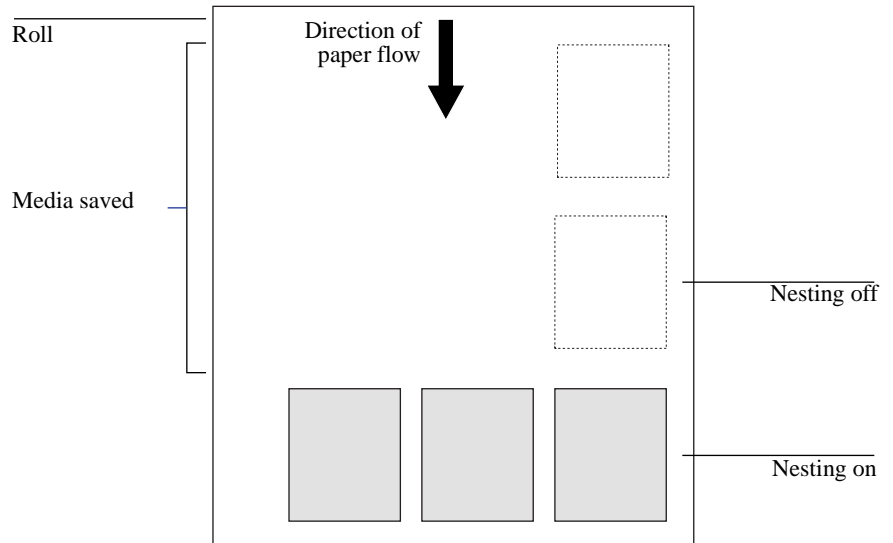

C47234010

### Automatic Rotation

The printer may automatically rotate a page in nesting (see page 7-13, *Which Pages Cannot be Rotated?*). It may do this even with a single page. Automatic Rotation does not apply to pages that have margins set to Smaller.

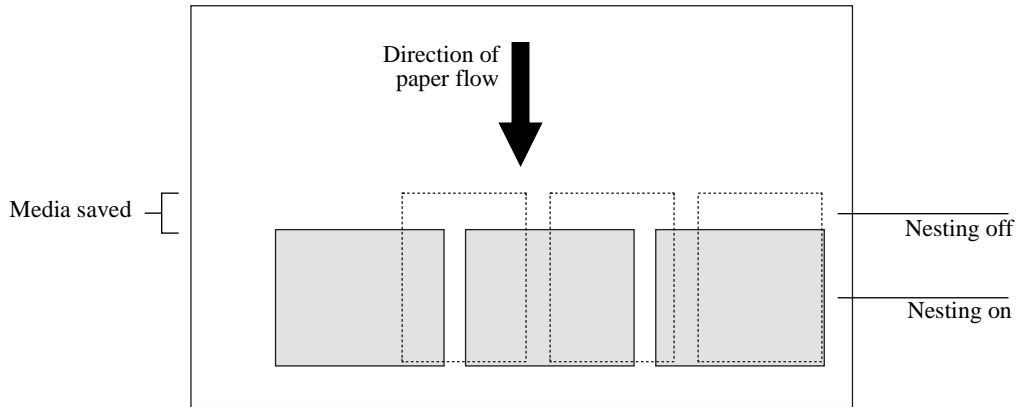

C4704011

---

#### NOTE

---

**The printer's automatic rotation does not apply to PostScript files. PostScript files will print in the orientation in which they were sent to the printer.**



## When Does the Printer Try to Nest Pages?

When all the following are true:

- The printer is loaded with roll media rather than sheet media.
- In the front-panel menus, Queue is ON (the default). See page 7-5, *What is the Queue?*
- In the front-panel menus, Nest is ON (that is, set to either Optimal or In order). See page 7-14, *Turning Nesting On or Off and Choosing the Nesting Method.*

## Which Pages Qualify for Nesting?

In order to be in the same nest, the individual pages must be compatible on both the following criteria:

- Color or monochrome

Either all are color or all are monochrome. Monochrome may include a color page rendered in grayscales by use of the front-panel **Color/Mono** key - see page 6-10, *Printing Color Images in Monochrome.*

- Print resolution

Either all are 300 dpi or all are 600 dpi - see page 6-14, *Print quality.*

- Print Quality all pages must have the same print quality setting (Best, Normal or Fast).
- All pages must be PostScript or all pages must be HP-GL/2.
- Margin sizes must be the same for all pages (normal, smaller or extended).

## Which Pages Cannot be Rotated?

Apart from obvious physical limitations on the roll, any HP-GL/2 page containing **raster data** will not be rotated.

Also Post script files are not auto-rotated.

## Turning Nesting On or Off and Choosing the Nesting Method

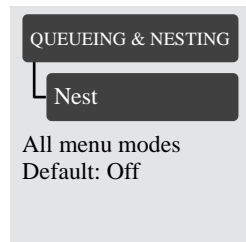

Nest Setting Selected	Printer's Response
Off	The printer will not nest pages.
Optimal	Choose this if you want to use the least amount of media. The printer will search all through the queue for suitable pages. It will nest the pages according to an algorithm that, for most combinations of page sizes, saves the most media. The resulting nesting pattern may still vary, depending on the size of the first page.
In order	Choose this if the speed with which you receive your prints is most important. The printer will try to nest pages in their queue sequence. If it comes across an incompatible page, it will stop searching and print any nest it has already created.

**NOTE:**The Optimal setting does not affect PostScript files. If Optimal is selected when printing a PostScript file, Nesting will function as if In order is selected.

### What Happens to Nesting if You Turn Queueing Off?

Turning queueing off does not turn nesting off for pages already in the queue. The printer prints all the pages in the queue before accepting any more files. As soon as you turn queueing off, the nesting setting also changes to off. When queueing is turned on again, the printer restores nesting to its previous setting.

## How Long does the Printer Wait for Another File?

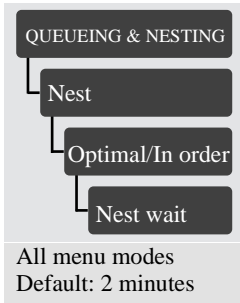

So that the printer can make the best nest possible, it waits after a file has been received to check if a subsequent page will nest with it or with pages already in the queue. This waiting period is the nest wait time. The factory default nest wait time is two minutes. This means that the printer waits for up to two minutes after the last file is received before printing the final nest. You can change this waiting time using the front panel menu. The available range is 1 to 99 minutes.

While the printer is waiting for nesting to time out, it displays the remaining time in the front-panel display. You can print the nest (cancel the nest wait) by pressing the **Form Feed and Cut** key.

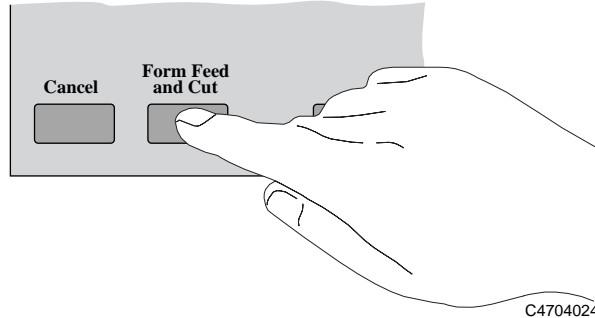

## Getting the Best from Nesting (Nesting and Margins)

### Right Margin Shift

The printer may reduce the right margin of the right-most page by up to 3 mm (0.08 in). This is done only if:

- the Size option in the Page format menu is set either to a Photo option or to a discrete standard size, and
- the roll of media loaded is slightly narrower than a standard size.

**NOTE:** If you select Smaller Margins with PostScript files, the printer uses the Normal margin settings. The HP PostScript drivers always use Extended margins and override the front-panel settings.

### Setting the space in between nested pages (nest spacing)

Another option you have to get the most from nesting is to change the size of the gaps between the pages printed onto the media (nest spacing). In the example shown below, the nest spacing is set to 30mm.

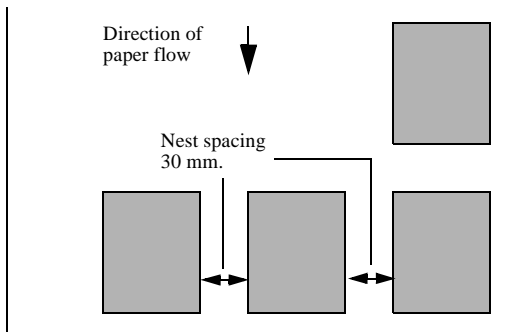

But by changing the nest spacing to 15mm you are able to print all four pages onto the same line, allowing more efficient use of the media.

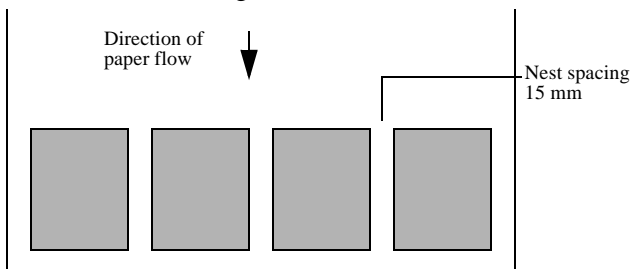

To set the nest spacing go to Page Format/Nest Spacing.

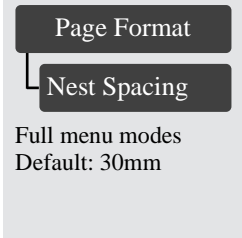

Nest spacing setting selected	Printer's response
30 mm 25 mm 20 mm 15 mm 10 mm 5 mm 0 mm	The printer leaves approximately the gap selected in between pages in a nest. The printer rounds up or down the gap selected with a maximum error of 1.25 mm.

## Nesting and the Rotate Feature

Since nesting may automatically rotate pages, the Rotate setting in the Page format menu is ignored while nesting is on. Pages with Smaller margin settings are not rotated.

**NOTE:**The printer's automatic rotation does not apply to PostScript files. PostScript files will print in the orientation in which they were sent to the printer.

Managing Your Prints  
Avoiding Media Waste by Nesting Pages

---

# Reconfiguring Your Printer

# 8

---

- Viewing the Current Overall Configuration of the Printer 8-2
- Viewing the Current Configuration of the Front-Panel Settings 8-5
- To Change the Front-Panel Settings 8-5
- Recalibrating the Printer for Accuracy 8-6
- Changing the Graphics Language 8-8
- Changing the Interface Settings 8-10
- To Change the I/O Time-out Setting 8-10
- Upgrading Your Printer with More Memory 8-11
- Turning on the Take Up Reel 8-12

---

## Viewing the Current Overall Configuration of the Printer

---

### 2500CP Only

---

To see the current configuration of your printer, print out the configuration print. The information contained on the configuration prints is described in the following tables.

### PostScript Configuration Print

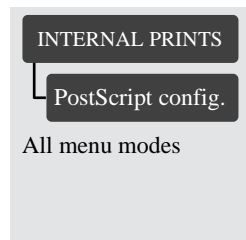

Item	Comments
Printer Name	The name assigned to your printer.
Code ver	The revision number of the printer's SIMMs and Hard Disk.
Adobe PostScript 3	The revision number of the printer's internal PostScript code.
RAM present	The size, in megabytes, of the printer's main standard memory, plus the amount of memory reserved for printing. <ul style="list-style-type: none"><li>■ This does not correspond directly to the size of your files on the computer, as explained on page 11-52, <i>File Size and Memory Usage</i>.</li><li>■ This is the total RAM, not the RAM currently free.</li></ul>
RAM available for PostScript	Amount of RAM available for PostScript processing.
Menu Settings	The current front-panel menu settings.
Internal Fonts	A list of the printer's internal fonts



## HP-GL/2 Configuration Print

INTERNAL PRINTS

HP-GL/2 config.

All menu modes

Item	Comments
Queueing & Nesting	The current queueing and nesting settings in the front-panel menu.
Utilities	The current menu mode setting (Full or Short).
Utilities -> Statistics	
Max X Max Y	These two figures, in millimeters, give the size of the current printing area, that is, the area in which the printer will print the next page unless it is changed. Normally each file received sets these dimensions with its Page Size command. <ul style="list-style-type: none"><li>■ Printing area = page size minus margins.</li><li>■ X represents the vertical (paper path) axis.</li><li>■ Y represents the horizontal (carriage path) axis.</li></ul>
Code rev	The revision number of the printer's internal code.
RAM present	The size, in megabytes, of the printer's main standard memory, plus the amount of memory reserved for printing. This is the total RAM, not the RAM currently free.
Ink	This is the type of ink installed in the printer.
Media	The media type which the printer currently selected in the front panel. For an explanation of media types, see page 3-4, <i>Supported Media Types</i> .
Language	Current language used in the front panel and on internal prints.

## Reconfiguring Your Printer

### Viewing the Current Overall Configuration of the Printer

<b>Item</b>	<b>Comments</b>
I/O setup	Current I/O configuration and time-out setting.
Image quality -> Printhead service	Current printhead service check frequency setting.
HP-GL/2 settings	Current Palette and Merge settings.
Device setup	Current Device setup menu settings: Graphics language, Cutter, Media advance, Skew tolerance, and Drying time, page accuracy.
Page format	Current Page format menu settings: Size, Mirroring, Margins, and Rotate.

## Viewing the Current Configuration of the Front-Panel Settings

- 1 Make sure either a roll or a sheet of media is loaded.
- 2 Print the Current Configuration Print, by pressing the up-arrow and down-arrow keys simultaneously.

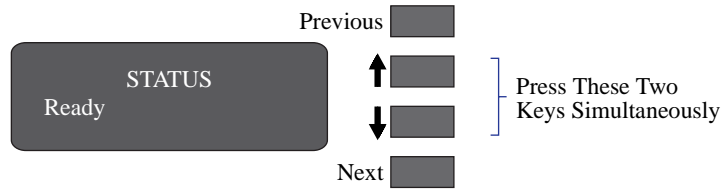

C4704019

The Current Configuration Print lists in an easy-to-read format all the items available in the front-panel menus, together with their current settings (in red italics). Note that some of the items don't appear in the front-panel display unless you have set Menu mode selection to Full in the Utilities menu (the default is Short, so that they don't appear). See the legend at the bottom of the print for details.

## To Change the Front-Panel Settings

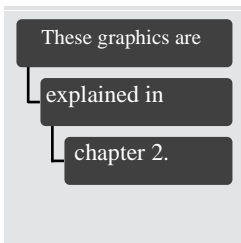

Chapter 2, *Using the Front Panel*, of this manual explains how to use the front-panel display, including how to change any of the settings. It also explains the small menu graphics that appear in the left margins of this manual whenever a particular menu item is explained.

The meanings of all the items in the front-panel menus are explained at the relevant point in this manual. Refer to the index at the back of the manual for the item you want to change.

## Recalibrating the Printer for Accuracy

### When to Recalibrate the Printer

Your printer was calibrated at the factory to ensure that it operates with the greatest accuracy in normal environmental conditions. If you are operating under significantly different conditions, you should recalibrate the printer as explained here. The printer's environmental specifications are given on page 13-6, *Environmental Specifications*. You may also need to recalibrate the printer if you have image quality problems. Before recalibrating the printer, you should always print the Image Quality test print to verify that you do have image quality problems. If you need to recalibrate the printer, you will be instructed in the image quality test procedure. See page 11-10, *Analyzing the Image Quality Test Results*, for detailed instructions.

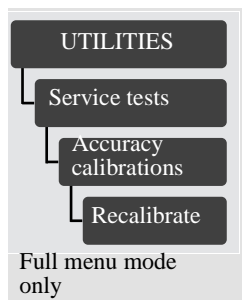

### To Recalibrate the Printer

- 1 Choose your media type (sheet or roll). Use HP Matte Polyester Film. Plastic-based media is more dimensionally stable than paper-based media. If you use another type of media, let the media stabilize at the ambient temperature of the printer for 10 minutes. For information on media types, see the *Media Guide for the HP DesignJet Printers* provided with your printer.
- 2 Unload any media that is currently loaded in the printer see page.
- 3 Go to Recalibrate in the front-panel menus, as shown in the left margin of this page.
- 4 Choose Create pattern. The message STATUS/Calibrating is displayed. If sheet media is loaded, it is ejected. If roll media is loaded, the printer asks you to remove it.
- 5 When prompted, load your media, using the procedure in chapter 3, *Working with Media*. If using sheet media, load it in portrait orientation, unless you chose D/A1-size media for an E/A0-size printer, in which case load it in landscape orientation.
- 6 When the calibration print is finished, remove it.

- 7 First ensure the media is dry, then rotate the sheet 90° counterclockwise and reload it printed-side down, so that the black arrows go into the printer first.

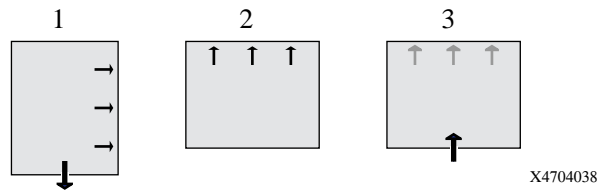

- 8 Go to Recalibrate again, and choose Measure pattern.

When the printer has finished measuring and has ejected the sheet, the recalibration procedure is finished.

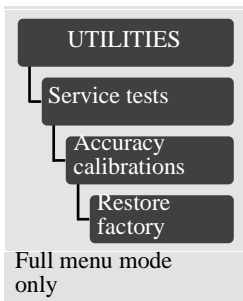

## To Restore the Factory's Calibration

From the Utilities menu, choose Restore factory.

## Changing the Graphics Language

### To Change the Graphics Language Setting

---

#### 2500CP Only

---

To change the graphics language setting, go to the Device setup/Lang menu. There are three selections, as follows:

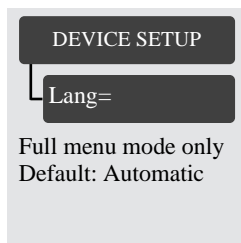

Graphics Language	Comments
<b>Automatic</b>	Choose Automatic to let the printer determine which type of file it is receiving. This setting works for most software applications.
<b>PostScript</b>	Choose PostScript if you are printing only PostScript files and your PostScript jobs do not include PJJ language switching commands.
<b>HP-GL/2</b>	Choose this setting if you are not working with PostScript files and: <ul style="list-style-type: none"><li>■ you have experienced image position problem.</li><li>■ you have experienced timing problems.</li></ul>

## Graphics Language and Networks

### For system administrators

If you are using the printer with a network spooler, consider having your system administrator modify the spooler to insert automatically the PJP language-switching commands at the beginning and end of each file. This allows the printer to switch automatically into the correct graphics language for your current print and returns the printer to the front-panel graphics language setting for subsequent prints. For information on ordering PJP reference information, see page 13-18, *Ordering Accessories*.

The HP PostScript printer driver for Windows provided with your printer, adds the PJP language-switching commands to your output file, allowing the printer to switch graphics languages automatically.

**NOTE:**When using a Macintosh you should select the Automatic or Postscript setting, otherwise you will not be able to connect to the printer.

## Changing the Interface Settings

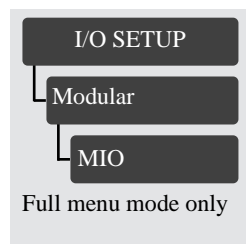

### Network

With a network interface (such as the HP JetDirect Print Server), refer to your network interface documentation for advice on any front-panel configuration. The front-panel menu is I/O Setup / Modular / MIO....

### Parallel

With a parallel interface, no front-panel configuration is necessary.

## To Change the I/O Time-out Setting

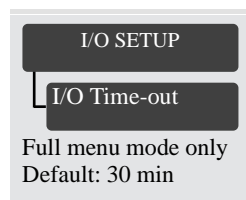

Some software applications do not write a file terminator at the end of a file. In this case, the printer does not know when the file is complete and will wait for more data until the end of the “I/O Time-out” period. By default, this period is 30 minutes. You can change the time-out setting in the front-panel menu to as little as 30 seconds.



## Upgrading Your Printer with More Memory

---

### **2500CP Only**

---

Your printer comes with 32 MB of memory plus 4 MB of internal printing memory. You can expand the memory up to a maximum of 68 MB by adding additional 4-MB, 8-MB, 16-MB, and 32-MB memory expansion modules. In addition to this memory, the printer has an internal hard disk drive used as extended memory for PostScript rendering and print management.

If you occasionally get “Out of memory” error messages when printing, this may be an indication that you need to add more memory to your printer. Adding memory may also slightly improve performance when printing some files.

---

### **2000CP Only**

---

Your printer comes with 4 MB of memory plus 4 MB of internal printing memory. You can expand the memory up to a maximum of 68 MB by adding additional 4-MB, 8-MB, 16-MB, and 32-MB memory expansion modules.

See page 13-18, *Ordering Accessories*, for HP part numbers for the memory modules. For installation details, see the Setup Guide supplied with the printer.

## Turning on the Take Up Reel

The Take Up Reel enables you to have very long prints without the need for you to be present. As the media is printed, it is automatically wound onto the Take Up Reel spindle.

**NOTE:**The default for the Take Up Reel is On.

- 1 When the Front Panel displays **Ready** press **Enter**.

**NOTE:**If the front panel does not display Ready press the Previous key until it does.

- 2 Use the ↑ or ↓ keys until the front panel displays **Device Setup**. Then press the **Enter** key.

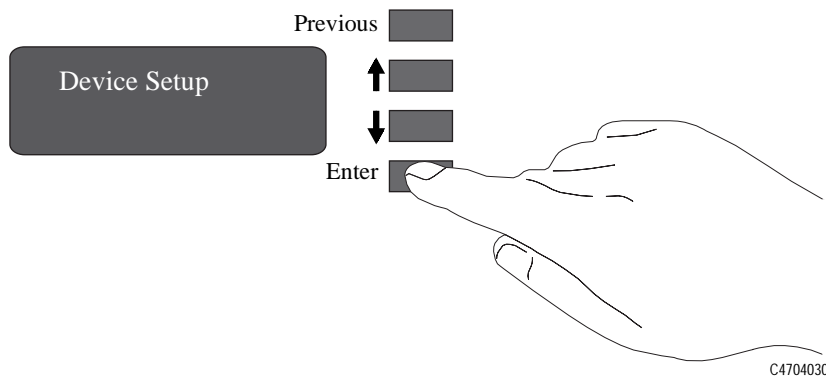

- 3 Use the ↑ or ↓ key until the display shows:



- 4 Use the ↑ or ↓ key until the display shows **ON**. Then press **Enter** to turn the Take Up Reel on.



**NOTE:**When the Take Up Reel is turned on:

- The cutter is turned off and will only work if the Form Feed and Cut button is

pressed on the Front Panel.

■ Queueing is turned on.

5 Press the **Previous key** until you get back to the display saying the printer is **Ready**.



---

# Controlling Image Quality

# 9

---

Selecting the Ink Emulation Mode 9-2

Calibrating the Color Output 9-3

Performing a Image Quality Test 9-4

Servicing the Printheads 9-5

Media Test Print 9-7

## Selecting the Ink Emulation Mode

---

### 2500CP Only

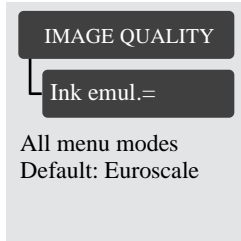

Your printer can emulate the color behavior of offset printing presses, allowing you to use your printer for color proofing. To get accurate colors for your proof, select the color emulation mode that matches your offset printing standards. The selections are:

- Native - No ink emulation
- Enhanced - Optimized version of native
- SWOP - U.S. Specification for Web Offset Printing
- TOYO - Japanese standard for offset press
- EuroScale - European standard for offset press.

---

### CAUTION

**If your application generates CYMK color values and you select Native ink emulation (No color adjustment), the printer may apply an excessive amount of ink which may affect image quality on some types of media. In extreme cases (more than 200% ink density) coated papers may become saturated, resulting in serious printhead damage.**

---

## Calibrating the Color Output

### 2500CP Only

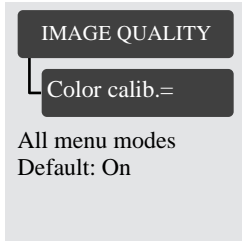

Color calibration improves color consistency between prints, and from one printer to another. The printer prints a test image and measures the image color with a sensor to generate a color calibration table that is applied to the PostScript imaging process. This table enables the printer to compensate for changes in the printheads over their lifetime, changes in media, and changes in the operating environment that affect color. The menu settings for Color calibration are:

- |     |   |
|-----|---|
| On  | The printer calibrates the color when: <ul style="list-style-type: none"><li>■ Ink systems are replaced.</li><li>■ A different media type is loaded.</li><li>■ Power is cycled using the Power switch on the rear of the printer.</li></ul> |
| Now | This selection causes the printer to immediately perform the color calibration procedure. If it is busy performing a task, it will finish the task first.   |
| Off | No color calibration is done.   |

**NOTE:**If queuing is on performing the color calibration will not affect jobs already in the queue.

## Comparing Color Output between Imaging and UV Ink Systems

The two ink types available for your printer have different color characteristics, this produces different color output depending on your configuration and image source.

For postscript files, the best match between the ink sets will be made with colorimetric mapping selected in the driver, however some colors may not be available in the addressable gamut of both ink sets.

For the 2000CP, the color matching will be determined by your application software and/or the RIPs abilities.

## Performing a Image Quality Test

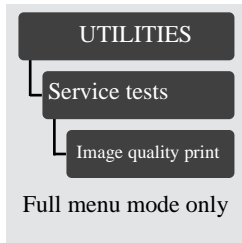

The image quality print helps you determine if you have image quality problems, and if you do, what the cause of the problem is and how to resolve it. The print contains patterns that are designed to highlight any image quality problems.

For detailed information on how to use this print, see page *11-5, Solving Image-Quality Problems*.



## Servicing the Printheads

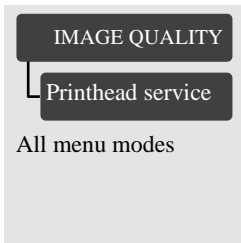

The Printhead Service selection in the Image Quality menu lets you:

- align the printheads
- refill the printheads from the ink reservoir
- select the frequency that you check the printhead for nozzle failures.

The three selections in this menu are described in the following sections.

### Aligning Printheads

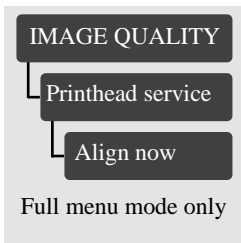

The Align now selection causes the printer to align the printheads immediately, or if an image is being printed, as soon as the current print job is done. The alignment procedure requires a minimum media size of A3 or B-size.

The printer will automatically perform an alignment when printheads are re-seated or the media type has been changed. You can use this feature if the image quality print indicated an alignment error.

### Refilling Printheads

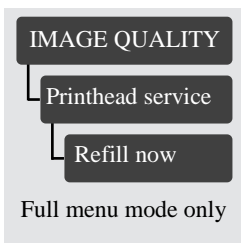

The Refill now selection causes the printer to immediately refill the printheads. Normally, it is not necessary to use this feature since the printer automatically refills the printheads with ink whenever it detects that there may not enough ink remaining in the printheads to print an E-size image. An example of when you might want to refill the printheads is before printing a long-axis print, to ensure that the printhead will not need to stop and refill in the middle of the print.

## Checking Printheads

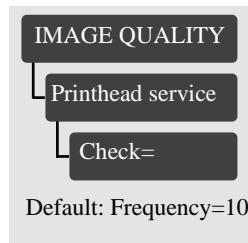

The printhead check function prints a test pattern and then analyzes the pattern to determine if any printhead nozzles are not placing ink on the media correctly. If nonfunctional nozzles are found, the printer will switch to other nozzles on the printhead to prevent any degradation in image quality. Eventually it will perform a set of actions to bring them to a better working condition. In this way, the printer is able to compensate for nonfunctional nozzles on the printheads.

For most users, the factory default frequency will provide the expected image quality without any intervention. However, for your convenience, you can set the check more frequently (up to every page) or disable it.

The Extended margins setting must be selected in order for the leading and trailing edges of an image to be error-corrected for nonfunctional nozzles. The selections in this menu are:

- |            |   |
|------------|---|
| Now        | This selection causes the printer to perform a printhead check immediately.   |
| Off        | The printhead check functions is turned off. Printhead checks are done only when you replace an ink system.   |
| Frequency= | This setting lets you select the frequency that printhead checks are made. You can select a printhead check to be done from every tenth page printed to every page printed. |

### For Roll Media

The printhead check is done:

- at the selected frequency
- whenever you replace an ink system
- when the power is switched off and then switched back on
- on request.

### For Sheet Media

The printhead check is turned off automatically. To check the printheads, load an A3 or larger sheet in landscape orientation (wide side of sheet first) and select Check= Now in the Printhead service menu. See page 3-39, *Loading sheet media*, for sheet loading instructions.

---

### NOTE

**If you are using a third-party Raster Image Processor (RIP) to print with your printer, the printer may not be able to switch to other nozzles. In this case, the printer will attempt to recover the nozzles.**

---

## Media Test Print

If you choose to print on non-endorsed media (*Custom Media*) it is recommended that you first print the Media Test Print. From the Media Test Print you can determine which print mode best suits the custom media you have loaded.

The Media Test Print is number of colored patterns with titles consisting of colored area-fills and colored lines. Each pattern and title corresponds to a media selection in the front-panel menu. By looking at each of the colored patterns and finding the best one produced, you can then select the corresponding media setting from the front panel menu.

When choosing the pattern with the best quality, keep these particular questions in mind:

- Are the colored area-fills inconsistent or blemished?
- Is the color of poor quality?
- Does ink bleed from one color to another?
- Are the lines broken, rough or incomplete?

### **IMPORTANT**

The Media Test Print is provided to help you print on non-endorsed media. Because HP has not tested these types of media you are responsible for the final color accuracy of your prints. If you need to improve the color of a print, you should modify it using your software application.

### **IMPORTANT**

If you print with an HP Endorsed Media, you do not need to test the media.

## How to perform the Media Test Print

- 1 When the front-panel displays SELECT MEDIA, use the ↑ or ↓ key to select Test media and press the **Enter** key.

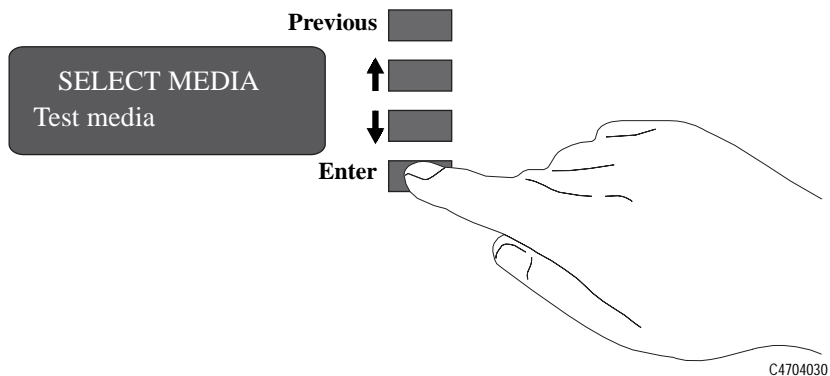

- 2 The front panel then displays:



- 3 On the front panel, select the **Best**, **Normal** or **Fast** key to suit your printing requirements and then press the ↓ key. This will produce a Media Test Print in either Best, Normal or Fast print mode depending on the selection you have chosen.

---

### NOTE

---

**Do not change the print mode setting until the printer has completed the Media Test Print.**

- 4 The front panel then displays:

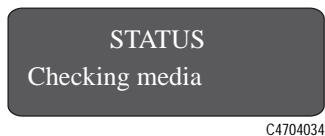

- 5 If the media has been correctly loaded, the front panel will then display:

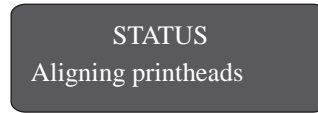

C4704034

The printer aligns the printheads by producing and calibrating the multi-color pattern.

---

**NOTE**

---

**If the media has not been correctly loaded, you will have to reload it and repeat steps 1 through 5 again.**

- 6 After completing the printhead alignment check, the printer automatically prints the Media Test Print. The front panel displays the following message:

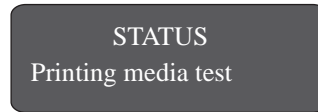

C4704034

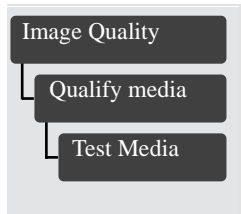

The print produced contains a number of colored patterns. From this print you can identify the best print quality mode for the custom media you have loaded. If media is already loaded and you want to perform the Media Test Print, you can select it from the front panel. Select Image Quality/Qualify Media/Test Media and press **Enter**.

## Changing the Print Quality when Media is Already Loaded

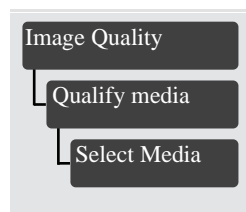

If, after loading and selecting a print mode for non-endorsed media, you want to change the print mode to another one, it is not necessary to remove and reload the media.

From the front panel menu select Image quality/Qualify media/Select media and press **Enter**. By scrolling using the  $\uparrow$  or  $\downarrow$  keys you will see the following print mode selections:

HP DesignJet CP Ink System UV (UV Pigmented Ink) Installed	HP DesignJet CP Ink System (Imaging Ink) Installed
UV Opaque vinyl	Coated paper
Heavy coated	Heavy coated
UV Custom media A	High-gloss photo
UV Custom media B	Semi-gloss photo
UV Custom media C	Imaging film-backlit
UV Custom media D	Opaque vinyl

**NOTE:** These print mode selections are only available when media is loaded and the printer has completed its initialization procedure.

While scrolling through the display you will see a \* displayed next to one of the media types, this shows the current media selected in the printer. It is also an alternative way of confirming which media is currently loaded.

By pressing **Enter** when the desired selection is displayed, you can change the print mode to the one displayed on the front panel.

### IMPORTANT

If you are printing on HP endorsed media, always select the same media print mode as the media loaded in the printer. Hewlett-Packard has tested these settings for optimum performance and print quality.

---

# Maintaining Your Printer *10*

---

Cleaning the Printer 10-2

Lens Maintenance 10-3

Normal Printer Use 10-6

Storing and Moving Your Printer 10-7

## Cleaning the Printer

---

**WARNING**

---

To avoid an electric shock, make sure that the printer is switched **OFF** and unplugged before you clean it. Do not let water get inside the printer.

---

**CAUTION**

---

Do not use abrasive cleaners on the printer.

---

**NOTE**

---

Any maintenance or repairs beyond those described in this chapter should be done by a qualified service technician.

### Cleaning the Printer Exterior and Inside the Doors

- Clean the outside of the printer as required with a damp sponge or a soft cloth and a mild household cleaner such as non-abrasive liquid soap.
- Over time, aerosol spray from the printheads may build up on the inside of the left and right access doors and inside the printer window. This aerosol buildup can be cleaned with a damp sponge or a soft damp cloth and a mild household cleaner such as non-abrasive liquid soap.



## Lens Maintenance

The optical sensor on the printhead carriage has a lens cover to protect it from ink aerosol and other contaminants. The lens cover is located on the lower right side of the carriage.

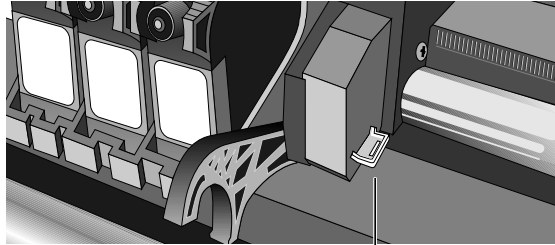

C4704151

Lens Cover

Over time, this lens cover will get dirty and need to be replaced. When the printer detects that the lens cover is dirty, it will display the message:

STATUS  
Lens maintenance

C4704034

You should replace the lens cover to prevent any problems with printer operations due to the optical sensor. Replacement lens covers are provided with your printer and are stored inside the right door of the printer. You may replace the lens cover immediately when you see the message or wait until the next time you need to replace an ink system.

## Replacing the Lens Cover

- 1 Press the **Replace Ink System** key on the front panel.
- 2 When the printer carriage stops and the front panel displays the message “*Open window to access printheads,*” open the window of the printer.

**NOTE:** Do not open the window before the “Open window to access printheads” message is displayed.

- 3 The printer will display the message:

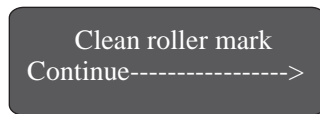

C4704034

- 4 You will find a small slotted white plastic insert on the left end of the media roller. With a soft tissue carefully clean the top of the plastic insert, ensuring it is perfectly clean.
- 5 The printer will display the message:

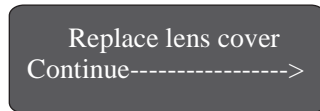

C4704034

- 6 Remove the dirty lens cover from the printhead carriage by pulling it straight out of the slot on the right side of the printhead carriage.

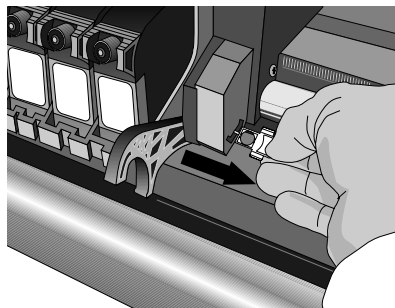

C4704149

- 7 Take a new lens cover from inside the right door of the printer. The message “Close right door to continue” will be displayed when you open the door.
- 8 Close the door after removing the new lens cover.

- 9 Making sure that you do not touch the glass portion of the lens cover, install the new lens cover into the slot. Make sure the cover is firmly in place.

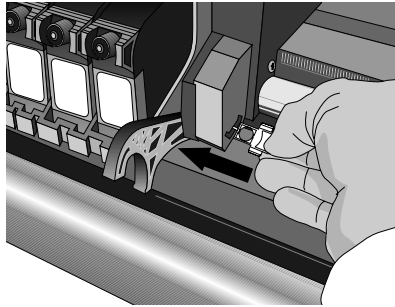

C4704150

- 10 Press the ↓ key on the front panel. You have finished replacing the lens cover.
- 11 Close the printer window.

## Normal Printer Use

“Normal” printer use means an average of 15 image prints with an area of 0.76 m<sup>2</sup>/print (8ft.<sup>2</sup>/print) per day. If your prints are smaller than this, the number of pages per day can be higher.

Under normal usage conditions, It will be approximately 5 years before you need maintenance. If you use the printer more than this, it will need maintenance service more frequently.

The printer keeps an internal count of total usage. When the usage has exceeded the amount where maintenance is required, the front panel displays:



STATUS  
Maintenance advised

C4704034

When this message is displayed, *Contact your local HP dealer or HP service engineer to arrange a maintenance service.* If your unit is still under warranty, or if you have purchased an HP Support Pack or HP Service Contract, this maintenance is covered without extra cost.

After the maintenance service, the message will disappear. If you choose to ignore the message, you can continue to use the printer as normal, but may encounter operational or print-quality problems.

## Storing and Moving Your Printer

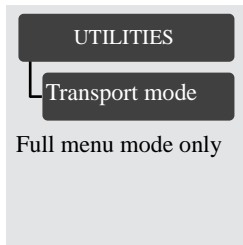

If you need to move your printer or store it for an extended period of time, you need to prepare your printer properly to avoid possible damage to the printer. To prepare your printer, follow the instructions listed in the following sections.

### Selecting Transport Mode

In the front-panel menu, select Transport mode in the UTILITIES menu, and press **Enter**.

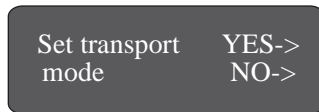

C4704034

- 2 Press the  $\uparrow$  key to select the Transport mode.

**NOTE:** If you press the  $\downarrow$  key, the printer terminates the menu session and return to the STATUS display on the front panel.

The printer displays the message “Accessing printheads” while moving the printhead carriage to the unloading position.

## Removing the Printheads

- 1 Open the window of the printer when the printer carriage stops and the front panel displays the message “Open window to access printheads.”

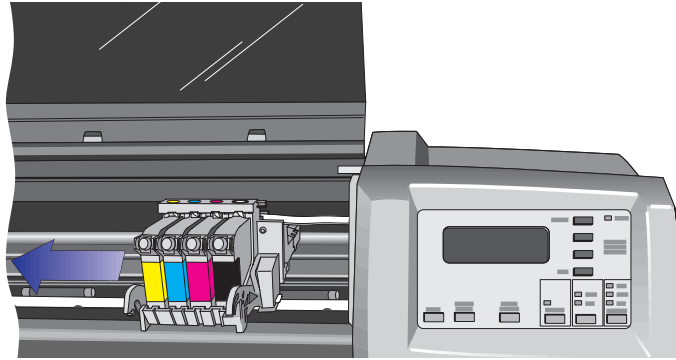

After you open the window, the front-panel displays the message “Remove all printheads”.

- 2 Press down lightly on the printhead you are removing and pull it toward you, removing it from its stall.

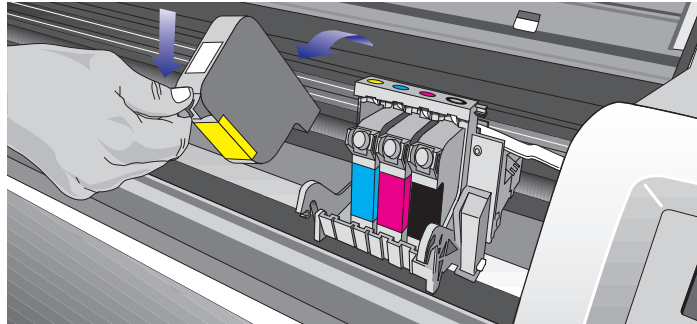

C4704135

- 3 Repeat step 2 for the remaining three printheads.

When you have removed all four printheads, the front panel displays the message “Close window to continue.”

- 4 Close the printer window.

The front panel displays the message “Open right door to access head cleaners”. Continue with the next section, *Removing the Printhead Cleaners*.

## Removing the Printhead Cleaners

---

### WARNING

---

**When you open the right door of the printer, the printhead cleaners move to the opening in the printer for removal. Keep hands clear of the opening until the printhead cleaners stop moving.**

- 1 Open the right door on the printer.

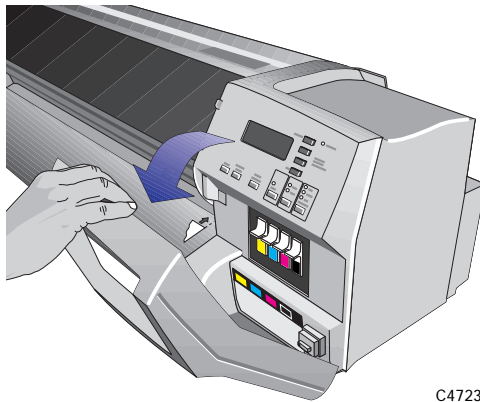

C4723114

- 2 After you open the right door, the front panel displays the message: “Remove head cleaners/Close right door.”

Maintaining Your Printer  
Storing and Moving Your Printer

- 3 Press down on the printhead cleaner handle and pull it out of the printer.

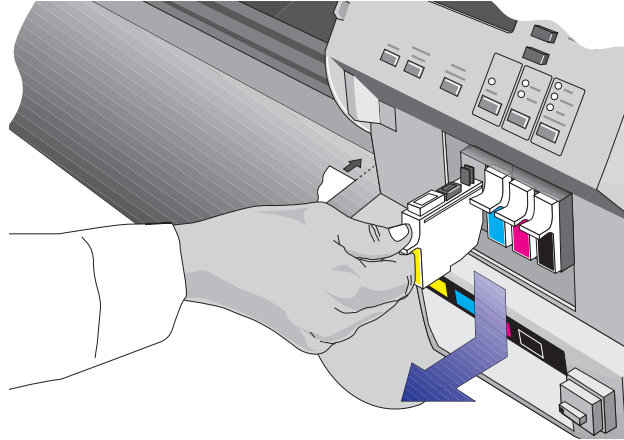

C4723138

- 4 Repeat step 3 for the remaining three printhead cleaners.
- 5 Close the right door on the printer.

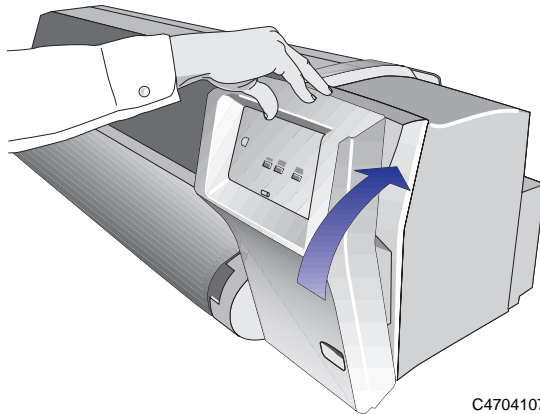

C4704107



The front panel displays the message “Open left door to access ink cartrg.”.

Continue with the next procedure, *Removing the Ink Cartridges*.

## Removing the Ink Cartridges

- 1 Open the left door on the printer.

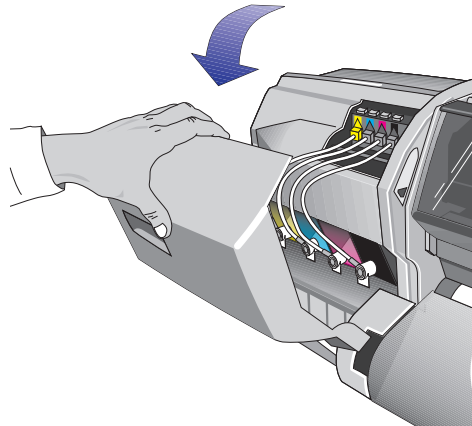

C4704108

After you open the left door, the printer displays the message “Remove all ink cartridge(s)” on the front panel.

- 2 While pressing down on the quick-connect release button (1), unplug the ink cartridge tube by pulling the tube connector away from the printer (2).

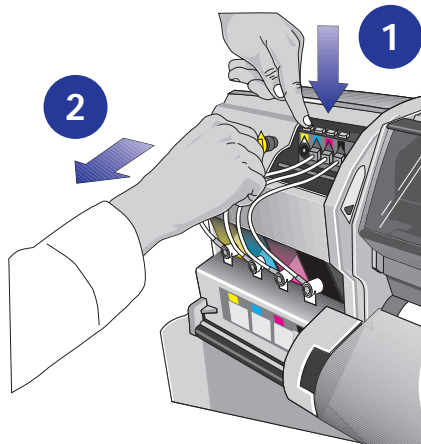

C4704113

---

**CAUTION**

---

**Never pull the ink cartridge out by the tube or connector. This may cause the ink cartridge to leak. Always grasp the body of the cartridge when removing or installing.**

- 3 Remove the used ink cartridge from the slot in the printer.

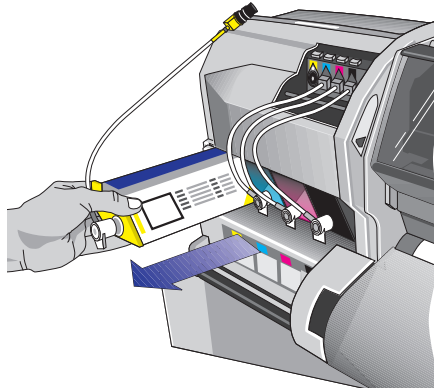

C4704143

- 4 Repeat steps 2 and 3 for the remaining three ink cartridges.

When you have finished removing all four ink cartridges, the printer front panel displays the message “Close left door to continue”.

- 5 Close the left door on the printer.

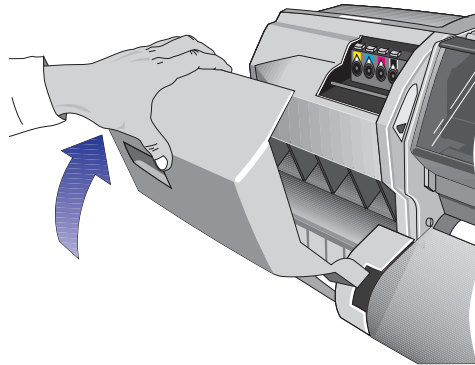

C4704148

After the left door is closed, The front panel displays “STATUS, Checking ink system” as the printer checks that all printhead cleaners have been removed. If the printer detects a printhead cleaner, it prompts you to remove it.

Once the printer has verified that all printhead cleaners have been removed, it moves the printer mechanisms to the transport positions and displays the message “Switch power off”.

## **Switching off and Disconnecting the Printer**

- 1** Switch the power off from the main power switch at the back of the printer.
- 2** Disconnect any cables connected to the printer.

**The printer is now ready for transportation or storage.**

### **IMPORTANT**

Store the Printheads and Printhead Cleaners in the HP DesignJet CP Ink System Storage Container see page 4-24, *Removing and Storing Partially Used Ink Systems*.

Maintaining Your Printer  
Storing and Moving Your Printer

---

# Troubleshooting

# *11*

---

A Note About Troubleshooting	11-2
Where to Find Help in Solving Problems	11-3
Finding the Source of Your Problem	11-4
Solving Image-Quality Problems	11-5
Solving Media-Handling Problems	11-28
Solving Ink System Problems	11-31
Clearing a Media Jam	11-44
Solving Communication Problems	11-45
Solving Problems with Image Position or Content	11-46
Solving Front-Panel Problems	11-51
Solving Miscellaneous Problems	11-54
Getting Help	11-56

## A Note About Troubleshooting

Much of the troubleshooting information contained in this chapter is provided to complement the printer's own internal image quality checking features.

---

### **2500CP Only**

The HP DesignJet 2500CP printer provides new printing concepts such as:

- Automatic Color Calibration
- Fault Tolerant Print Modes
- Image Quality Consistency
- Continuous Printing
- Color Emulation
- Out of Ink Detection (when “Printhead check” is ON and frequency is set to “1” in the front-panel menu).

Troubleshooting should be an intuitive process with the printer either correcting its own faults or conveying a fault message via the front-panel display, prompting you to take corrective action. You should therefore only need to refer to these procedures if the printer does not correct the problem or instruct you via the front-panel display.

The order of problem solving is:

- 1 Automatic internal corrective action
- 2 On demand corrective action
- 3 On-line and printed troubleshooting procedures.

## Where to Find Help in Solving Problems

- To find the meaning of front-panel messages, see chapter 12, *Front-Panel Messages*.
- If you know the problem is related to a certain task, first check the relevant section in this manual, for step-by-step procedures. Use this manual's index or table of contents to find the section. For example, if you are having difficulty with page formatting, refer to chapter 5, *Controlling the Page Format*.
- If the problem is related to the quality of your printed images, refer first to the section: Solving Image-Quality Problems 11-5
- Refer to the appropriate topic in this chapter:
  - *Solving Media-Handling Problems*
  - *Solving Ink System Problems*
  - *Clearing a Media Jam*
  - *Solving Communication Problems*
  - *Solving Problems with Image Position or Content*
  - *Solving Color Accuracy problems*
  - *Solving Front-Panel Problems*
  - *Solving Miscellaneous Problems*.
- If the problem could be related to your software driver, and you are using an HP driver, refer to the driver's troubleshooting documentation and the on-line help in your application software.
- If the problem has no obvious cause, refer to “*Finding the Source of Your Problem*” on the next page.
- If you still cannot solve the problem, see page 11-56, *Getting Help*.

## Finding the Source of Your Problem

- 1 Look at the front-panel display for messages. See chapter 12, *Front-Panel Messages* for an explanation of front-panel messages.
- 2 Test the printer.
  - Switch the printer off at the power switch at the back of the printer. Make sure that the power cord is firmly inserted in the printer and plugged in to an outlet that you know works.
  - Switch the printer on. Print an internal print. If the printer prints the internal print correctly, the problem is probably not with the printer.
  - Depending on the nature of the problem, you may want to print the image quality print explained on page 11-8.
- 3 Test your computer hardware and interface.
  - Make sure that you have the correct interface cable between the computer and the printer and that it is firmly connected to the correct ports (see the Setup Guide).
  - Check that your printer's graphics language setting (in Device setup / Lang) matches the requirements of your software.

If you have changed your interface, switch the printer off and then on again before trying to print.



## Solving Image-Quality Problems



**NOTE:**To achieve the best performance from your printer, only use genuine HP accessories and supplies, whose reliability and performance have been thoroughly tested to give trouble-free performance and Photo-quality prints. For details of HP media, see page 3-4, *Supported Media Types* and the *Media Guide for the HP DesignJet CP Printers* supplied with the printer.

### How to Proceed with the Image Quality Print Diagnosis

Solving image quality problems with the UV Pigmented ink is exactly the same as with the Imaging ink. Whenever you suspect that your printing is not correct, it is advisable to perform the Image Quality Test.

Please note that the UV Pigmented ink produces sharp images but not photo-quality as it has different characteristics to the Imaging ink. This is because the UV Pigmented ink is designed for enhanced indoor and outdoor lightfastness, and not photo-quality imaging.

You can expect to see the following differences:

- A print produced with UV Pigmented ink will have a slight matte appearance compared to one produced with Imaging ink, which has a brighter glossy appearance.
- The volume and density of ink used to produce a print with UV Pigmented ink is different compared to Imaging ink. This print quality may sometimes have “speckling” (a very slight graining effect) which is a normal characteristic of the UV Pigmented ink.
- You may sometimes see minuscule patterns in the print, which can be mistakenly construed as banding. This is a normal characteristic of the UV Pigmented ink and is caused by the placement and density of the ink on the media.

As HP has not tested non-endorsed media, the appearance of a print may differ to one produced on endorsed media. Therefore it can only be used as an indication of a possible print problem. It is recommended that you change to an endorsed media to confirm a problem.

**NOTE:***Before starting any corrective action:* If the printer has not performed a printhead check or printhead alignment check recently, select the printhead alignment check from the front-panel menu (see page 9-5, *Aligning Printheads*) and then reprint the image. If the image quality is still bad, proceed with the following section.

## If the Color is Not as Expected

There is no direct comparison between prints produced with the UV Pigmented inks and Imaging inks. The UV Pigmented ink has different characteristics to the Imaging ink, because it is designed for enhanced indoor and outdoor lightfastness, and not for photo-quality imaging. You will see a slight matte appearance to a print produced with UV Pigmented ink, which is a normal characteristic.

If you still suspect that the color is not correct, check the following:

- Were all three components for each ink color set changed together?  
The printhead, printhead cleaner, and ink cartridge should all be new every time you replace a color.
- Make sure all the components for each ink color set are the same type of ink, if they have been previously stored in the HP DesignJet CP Ink System Storage Container.
- Are all four ink colors that you are using the same type of HP ink system? ***Never mix UV Pigmented ink and Imaging ink systems.*** Check that each ink cartridge is the same type of ink as the printhead.
- Were all three components of the ink set installed before the date on the box?

If you are printing on non-endorsed media (*Custom Media*) the final color accuracy of your prints is your responsibility.

- Try improving the print color from the software application.

## Some General Information About the Image Quality Test

One of the printer's internal prints is the Image Quality Print test, accessed from the Utilities / Service tests / Image quality print menu. Whenever you suspect that your printing is not correct, it is advisable to perform this test to help diagnose the problem. The Image Quality Print will help you differentiate between possible printhead errors and other problems such as incorrect front-panel selection, driver or RIP configuration or mechanical problems.

Correct diagnosis of print problems will help HP Customer Support Centers to provide an accurate solution to any Image Quality problem you are experiencing.

## Identifying the Printhead Components

The primary components of the printhead are shown in the illustration below.

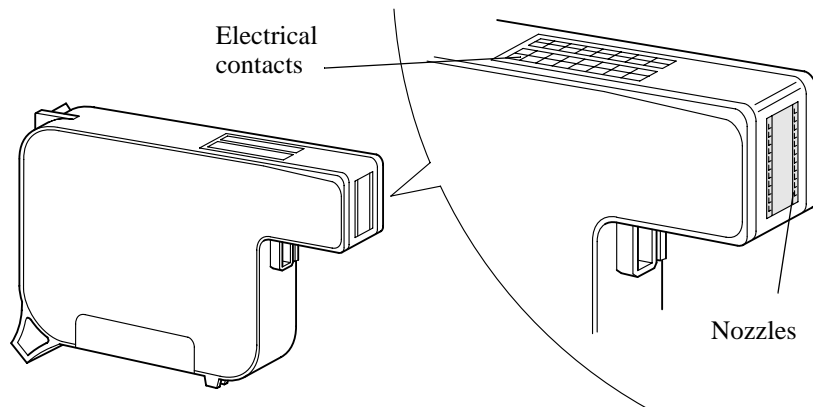

C472368

## How to Use the Image Quality Print

- 1 The Image Quality Print prints in A3 and B sizes so you must have media loaded (roll or sheet) that is this size or larger. **Do not use 3M Changeable Opaque Imaging media or equivalent.**
- 2 Use the same type of media that you were using when you found the image quality problem.
- 3 Study each of the test patterns in the order listed to determine the type of image quality problem.
- 4 If you are using non-HP media and after the Image Quality Print test you still have the same quality problems, change to genuine HP media and repeat the Image Quality Print test (not with 3M Changeable Opaque Imaging media).

## Printing the Image Quality Print

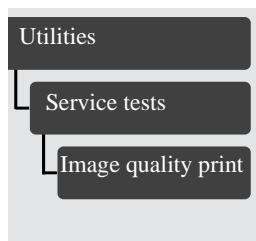

Select the Image Quality Print from the Utilities / Service tests menu, then press **Enter** to print the test.

The printer will print out a series of images named Test 1 to Test 5. The Image Quality Test print looks like this:

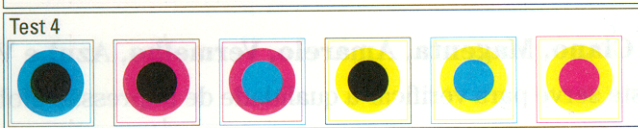
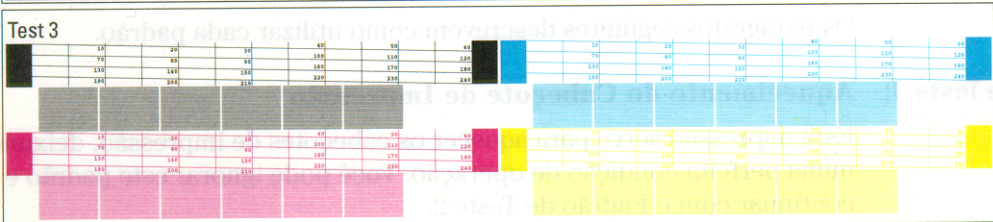

Revision 1.0  
**Image Quality  
Print**

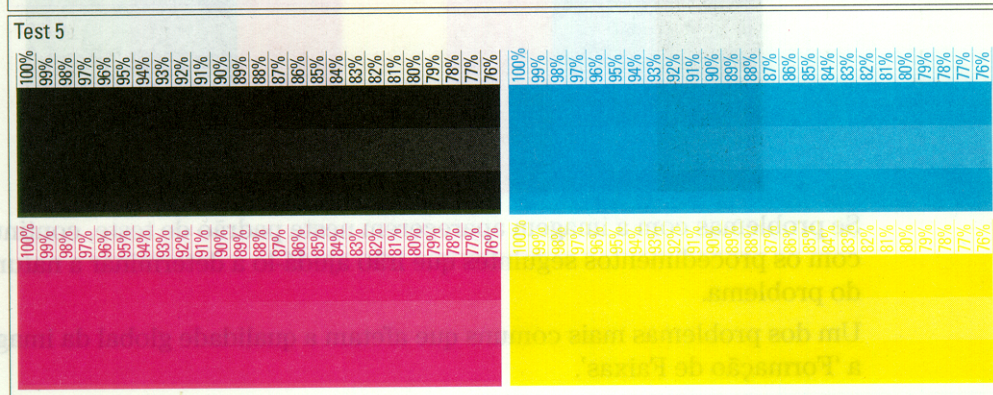

## Analyzing the Image Quality Test Results

The following paragraphs describe how to use each pattern.

### Test Pattern 1: Printhead Warm-Up

This print warms up the printheads, leaving them in a perfect operating condition. You can ignore this pattern and continue with Test Pattern 2.

### Test Pattern 2: Black, Cyan, Magenta, Yellow, Red, Blue, Green Test

This test pattern checks for overall image print quality.

### IMPORTANT

If you do not see any problems with the image quality test (similar to the example shown below), then the printer is functioning correctly. The problem may be with your RIP, driver, etc. See page 11-22, *No Printing Defects Found in the Image Quality Print* for more troubleshooting information.

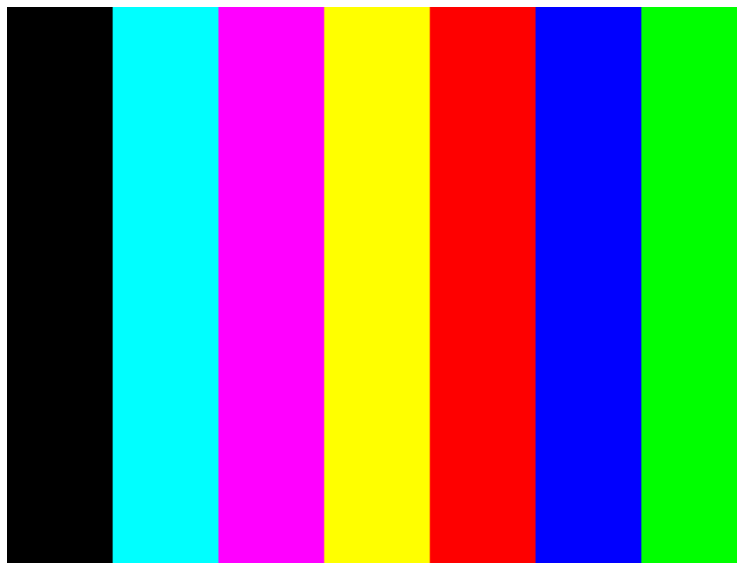

If you see image problems in this test pattern then continue with the following procedures which will help you determine the nature of the problem.

One of the most common problems that affects the overall image quality is 'Banding'.

## What is Banding?

Banding is when you see repetitive horizontal bands within your printed image (these may appear as light or dark bands).

The test pattern is printed with four primary colors; black, cyan, magenta and yellow. The three secondary colors printed are; red, blue and green and they are formed by mixing the primary colors as shown in the table below:

Secondary Color	Primary Color Components
Red (R)	Magenta (M) and Yellow (Y)
Blue (B)	Magenta (M) and Cyan (C)
Green (G)	Cyan (C) and Yellow (Y)

## Solving the Problems

The main causes of banding are:

- Printheads
- Media advance.

### Banding Caused by Printhead Problems

If the test pattern has clear or dark horizontal bands in one or more of the primary color columns, then several of the secondary color columns will also have the same type of bands in the same position (but perhaps with less intensity).

These bands are caused by two types of printhead nozzle failure; either nozzles not printing, or nozzles misdirected. See page 11-16, *Nozzle Print Test* for more information.

In the following **Example A**, several nozzles in the magenta printhead are not printing. There will be clear repetitive bands (perhaps white) in the magenta column. Consequently, you will see lower intensity bands in the same print position in the red (M + Y) and blue (M + C) secondary color columns.

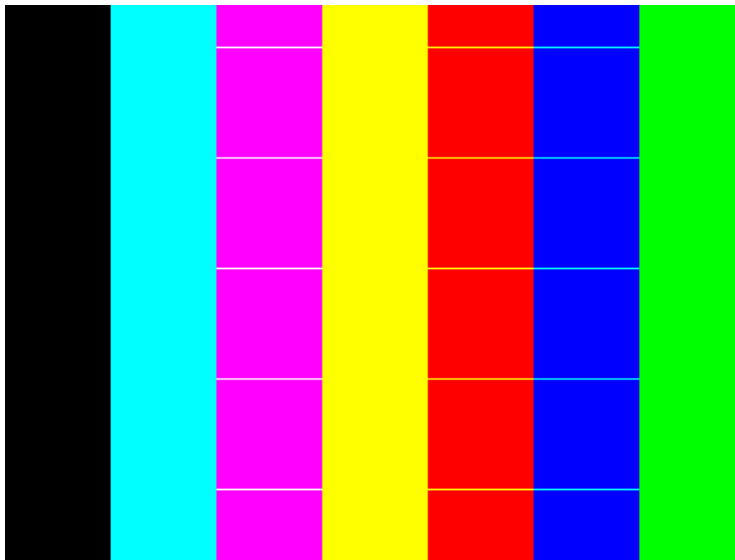

**Example A**

Problem	See:	Corrective Action
<p><b>1</b> Banding in cyan, blue and green columns only, but more evident in cyan than in blue and green columns. This is an indication that the cyan printhead may require servicing or could be damaged.</p>	<p>–</p>	<p>Refer to test 11-16, <i>Nozzle Print Test</i> for the cyan color. Verify this problem and see the recommended actions.</p>
<p><b>2</b> Banding in magenta, red and blue columns only, but more evident in magenta than in red and blue columns. This is an indication that the magenta printhead may require servicing or could be damaged.</p>	<p>Example A</p>	<p>Refer to test 11-16, <i>Nozzle Print Test</i> for the magenta color. Verify this problem and see the recommended actions.</p>



Problem	See:	Corrective Action
<p><b>3</b> Banding in yellow, red and green columns only, but more evident in yellow than in red and green columns. This is an indication that the yellow printhead may require servicing or could be damaged.</p>	–	<p>Refer to 11-16, <i>Nozzle Print Test</i> for the yellow color. Verify this problem and see the recommended actions</p>
<p><b>4</b> Banding in black column only. This is an indication that the black printhead may require servicing or could be damaged.</p>	–	<p>Refer to test 11-16, <i>Nozzle Print Test</i> for the black color. Verify this problem and see the recommended actions.</p>

### **Banding Caused by Media Advance Problems**

Another type of banding is caused by an inaccurate media advance. The printer prints an image in ‘bands’ or ‘swaths’ which have fixed widths depending on the advance of the media roller. If the advance of the roller differs from the theoretical advance, there will be banding (horizontal repetitive bands along the test pattern) in all the primary and secondary color columns.

The bands can appear as dark bands, due to a shorter advance of the roller which causes an overlap, or lighter bands due to a longer advance causing spaces.

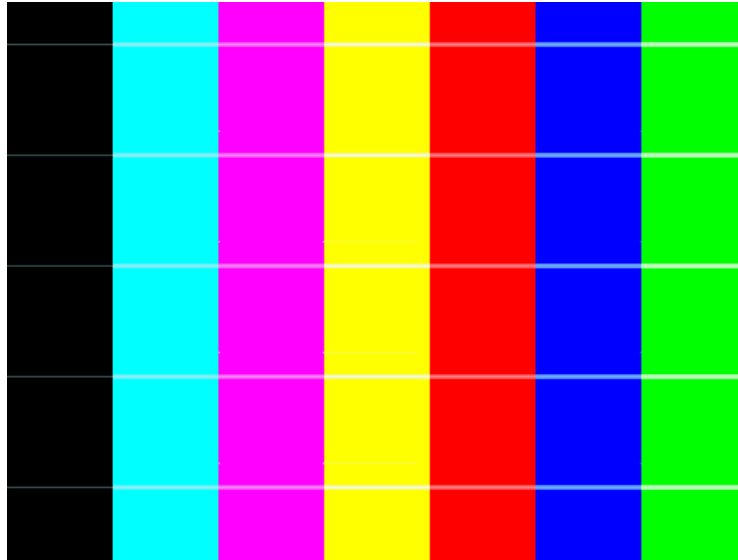

**Example B**

<b>Problem</b>	<b>See:</b>	<b>Corrective Action</b>
1 Banding in all color columns.	Example B	Refer to 11-20, <i>Color Alignment Quality Test</i> The causes are not related to misalignment but the troubleshooting actions are the same.

**NOTE:**It is also possible that the banding was caused because you were using non-HP media. The performance of your printer can only be guaranteed if you use genuine HP media.

Banding is the most common problem that can affect your image quality but another problem that may affect them is color misalignment.

## Problems Due to Misalignment

There are two types of misalignment; vertical and horizontal, refer to page 11-20, *Color Alignment Quality Test* for more information.

Misalignment between two primary colors when creating a secondary color can cause two different effects:

- If there is horizontal misalignment of the colors this will create banding.
- If there is vertical misalignment of the colors, it will create gaps or overlaps between colors, see **Example C**.

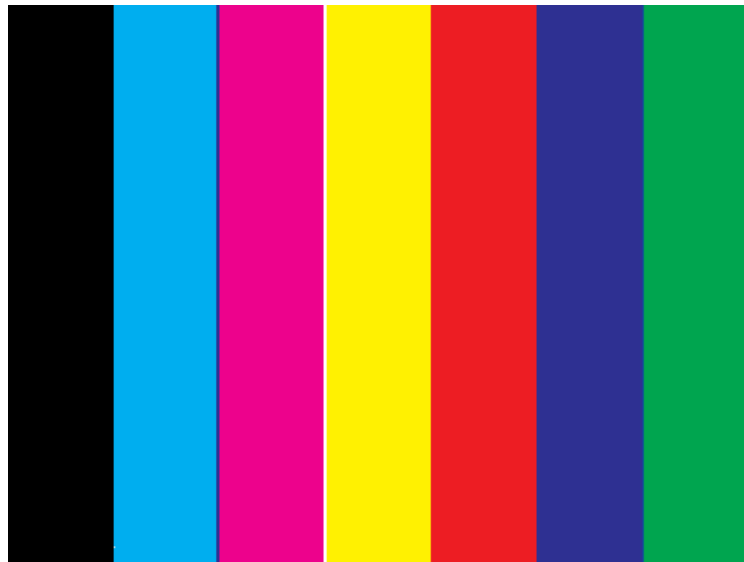

**Example C**

Problem	See:	Corrective Action
<b>1</b> Black, cyan, magenta and yellow columns are correct but banding in any, or all of the secondary color columns. This is an indication that there is a horizontal misalignment.	-	Refer to 11-20, <i>Color Alignment Quality Test</i> and verify this problem. See the recommended actions.
<b>2</b> Different colors visible in the spaces between some or all of the columns (depending on the color of the printhead that is misaligned) This is an indication of vertical misalignment.	Example C	Refer to 11-20, <i>Color Alignment Quality Test</i> and verify this problem. See the recommended actions.

**NOTE:**It is also possible that the banding was caused because you were using non-HP media. The performance of your printer can only be guaranteed if you use genuine HP media.

### Test Pattern 3:

#### Nozzle Print Test

#### IMPORTANT

Use this test purely to confirm an error highlighted in *Test Pattern 2*:. Some of the printhead nozzle problems that you will see in this pattern do not mean you will not get perfect image quality results. The printer has internal corrections that will hide many nozzle defects.

In this test all the 240 nozzles of each printhead are tested. For each of the four colors you will see the numbers 10 to 240 over the diagonally stepped lines in increments of 10. These numbers correspond to the nozzle number that prints each step.

There are two printhead nozzle errors:

- Nozzles not printing
- Nozzles misdirected.

## Nozzles not printing

There are two ways to see this problem, it is easier to see the error from the first check. See example D.

- 1 In the top pattern, marked with numbers, if the diagonally stepped lines are broken in one or more steps it indicates that this specific nozzle(s) may be blocked and are not printing. White lines will also be visible in the area fill at both sides of the pattern.
- 2 Below the top pattern there is a set of horizontal straight lines. When one or more nozzles are not printing the corresponding lines will be missing.

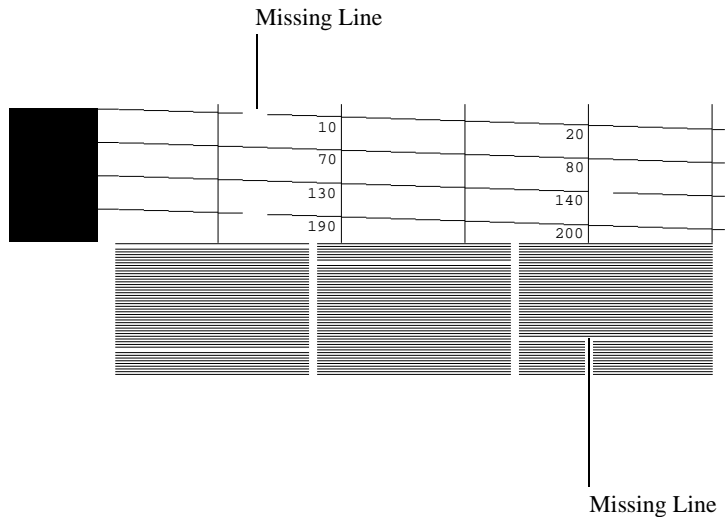

**Example D**

### Nozzles misdirected

If all the stepped lines are visible in the top pattern, then all the printhead nozzles are printing. However the nozzles could still be misdirected, possibly due to some dried ink around the nozzles, as shown in the following example:

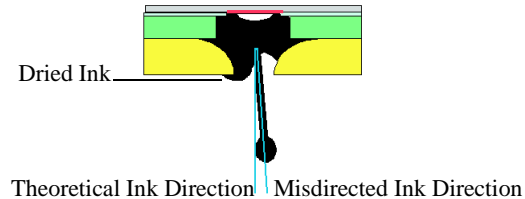

There are two ways to see this problem (see **Example E**), it is easier to see the misalignment from the second check.

- 1 In the top pattern, marked with numbers, if the diagonally stepped lines are not equally positioned in every step it indicates that this specific nozzle(s) may be misdirected.
- 2 Below the numbered pattern there is a set of horizontal straight lines. When one or more nozzles are misdirected there will be unequal spaces between the corresponding lines.

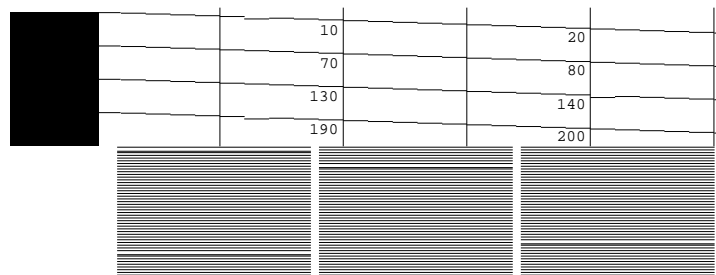

**NOTE:** Some of the printhead nozzle problems that you will see in this pattern do not mean you will not get perfect image quality results. The printer has internal corrections to hide many nozzle defects.

Problem	See:	Corrective Action
<p><b>1</b> Some printhead nozzles, in any one color, are not printing. Proceed with Corrective Action a.</p>	<p>Example D</p>	<p><b>a</b> From the Image Quality/ Printhead service / Printhead check Menu, set to Now to run the printhead check, then reprint your image. If the problems are still present, continue with Corrective Action b through d.</p>
<p><b>2</b> Printhead nozzles are misdirected in any one color. Proceed with Corrective Action b.</p>	<p>Example E</p>	<p><b>b</b> From the Utilities / Service tests menu, select “Recover printheads” to run the printhead recovery process, then perform a printhead check.</p> <p><b>c</b> Print the Image Quality Print again to see if there has been any improvement.</p> <p><b>d</b> If there has been no improvement, try reinstalling the ink system components and print the Image Quality Print again. See page 11-31, <i>Solving Ink System Problems</i>.</p> <p><b>e</b> If the error is still present replace the Ink System, corresponding to the bad color and repeat the image quality test.</p> <p><b>f</b> If the error continues contact HP support. See the page 11-56, <i>Getting Help</i>.</p>

**Test Pattern 4: Color Alignment Quality Test**

This test pattern is to check the color alignment, and produces six patterns each with two different primary colors. In each pattern you will see primary color circles. If there is misalignment between the primary colors the composite color will be present in one part of the circle and white will be visible at the opposite side of the circle.

There are two types of misalignment (See **Example F**):

- Horizontal - when the misalignment is in the horizontal axis
- Vertical - when the misalignment is in the vertical axis

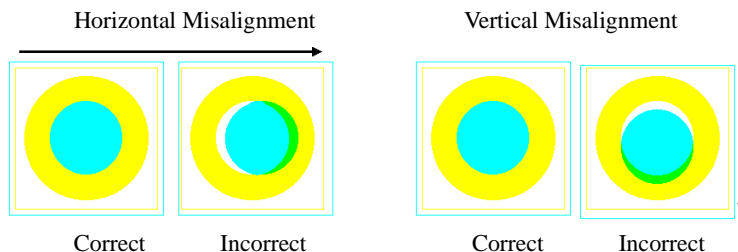

**Example F**

Problem	See:	Corrective Action
1 Third color present/ misalignment in either the boxes or circles of the test image.	Example F	<b>a</b> Perform the printhead alignment check using genuine HP media then print the Image Quality Print again to see if there has been any improvement.  <b>b</b> If there is no improvement in the Image Quality Print contact HP. See the page 11-56, <i>Getting Help</i> .



**Test Pattern 5. Color Variation Pattern Test**

This test produces four boxes: black, blue, cyan and yellow. In each box there are three horizontal bands; the two outer bands are 100% shade, the inner band is shaded from 100% scaling to 75%.

The purpose of this test is to determine at what percentage the middle shading becomes visible from the two outer bands. The best way to do this is to cover the box with a piece of paper and slide the paper horizontally across the box. Stop as soon as you see a different shade in the middle box. You can then determine the percentage scaling from the figure at the top of the box.

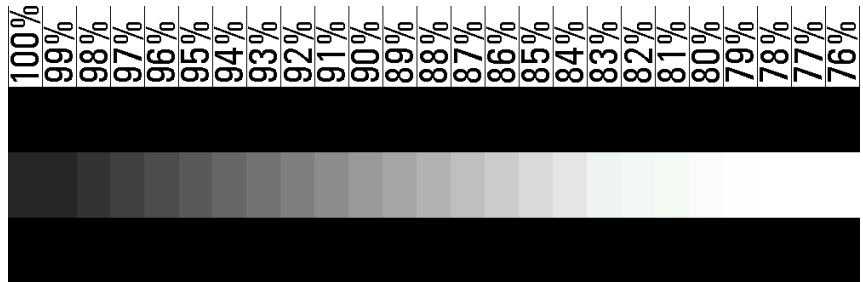

Correct  
**Example G**

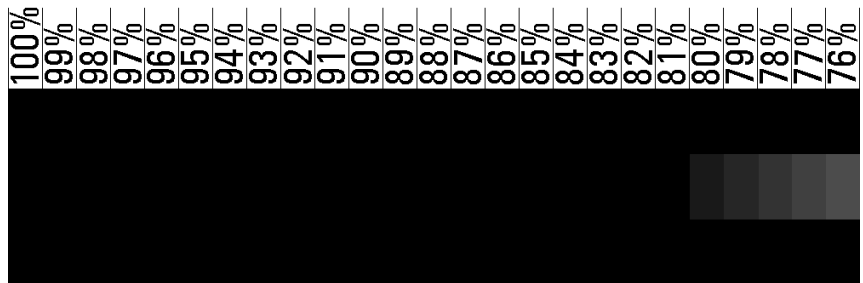

Incorrect  
**Example H**

Problem	See:	Corrective Action
1 If there is no apparent color difference in the center box at the 90% mark, this indicates that the printhead is producing incorrect size ink drops.	Example H	a Select Color Calibration to Now.

## No Printing Defects Found in the Image Quality Print

If all the test patterns from the Image Quality Print are correct and you still experience print quality problems, here are some of the more likely causes to check:

- the print mode used in your printer is incorrect (this is defined by the printer's front-panel menu selections)
- non-HP driver
- the RIP (If you are using one)
- the software applications you are using.

Use the following table to configure your system correctly.

What to Configure	Configuration Setting	Optimal Setting
Printer Front-Panel Menu	Media	Unload the current media and load it again while changing the media type in the front panel.
	Dry time	Set to Automatic.
HP PostScript driver (Windows or Mac)	Print mode setting	Set to Best.
Non-HP drivers (Software RIPs)	The settings available depend on the driver. The most typical settings are: <ul style="list-style-type: none"><li>■ Image Quality Settings</li><li>■ Half Tone</li><li>■ Media selection</li></ul> See the user's guide for your application for more information about its print quality settings.	In your software application: <ul style="list-style-type: none"><li>■ Set Image Quality to Best</li><li>■ Use no Half Tone (or printer default.)</li><li>■ Make sure that the media setting matches the media loaded in your printer.</li></ul>

## Solving Color Accuracy problems

### **2500CP Only**

These are two areas you should review when troubleshooting a color accuracy problem:

#### **Configuration**

Check that you are using the correct driver setting and CRD information for your software. Check which ink emulation mode has been selected in the front panel; see page 9-2, *Selecting the Ink Emulation Mode*

#### **Media**

Ensure the media loaded is genuine HP media and the correct media type selected on the front panel.

### **Color Consistency problems**

- Some media may discolor or change with age. Check that your media is fresh and has been stored correctly.
- If the environmental conditions you are printing in change rapidly, you may see changes in the color consistency. Perform the color calibration procedure.

## Configuration

The configurations of the printer, the driver, and/or the Software RIPs define how ink is applied to each type of media. Use the information in the following table to configure your printer and software for best color accuracy.

Location of Setting	Setting Description	Selection
Printer Front-Panel Menu	Media	■ Set to match the media type loaded in the printer. See page 3-4, <i>Supported Media Types</i> .
	Color Calibration	■ Select Color Calibration to Now.
	Printhead check / Frequency	■ Set to 1 page.
Non-HP drivers (Software RIPs)	Media or equivalent setting	■ Set to match the media type loaded in the printer. See the documentation that came with your software for information.
	Color correction option or equivalent.	■ Do the color correction calibration if one is available.

## Media

Always make sure that you are using the appropriate media for your image and that it is consistent with your software application. To ensure color accuracy and print-quality performance of the printer, use only media types that have been certified for your printer. Use of non-HP media or HP media not certified for the your printer may significantly reduce the color and print quality of your images. For details of HP media, see page 3-4, *Supported Media Types* and the *Media Guide for the HP DesignJet CP Printers* supplied with the printer.

---

**NOTE**

**To have accurate colors, the media settings must match the type of media you have loaded in the printer.**

**If you are using non-HP media with HP drivers, the colors in your print may not be accurate.**

---

## Where to Find Additional Information

The means of accurately managing the colors printed by your printer vary with the software application and driver being used. Refer to the following documentation:

- The Software Application Note for your application, in the specific package shipped with your printer.
- On-line documentation in the drivers shipped with your printer. If you cannot find any reason for the discrepancy, before getting help, find out for which CMYK printer inks the colors have been specified.

### Non-PostScript

Additionally, remember that for your printer may be configured to use one of its internal pen palettes instead of your software's palette (which is the default). See the section starting on page 6-3, *Changing Pen Widths and Colors Using the Internal Palettes*.

### If There are Slightly Warped Lines

- The media itself may be warped. This can happen if it has been used or stored in an extreme environment. For all environmental specifications, see page 13-6.

### If There are Blurred Lines (Ink “Bleeds” from Lines)

- Perhaps you have adjusted the drying time in the front-panel menu to speed up the printer output. Set “Drying time” to “Automatic”.

For details of drying time adjustments, see page 3-44.

### If there is a horizontal line 2 inches (5.5 cms) from the start of your image.

- If Margins are set to Smaller, the printer pauses briefly to cut the top margin after printing has started. On some non HP-media this can leave a noticeable mark. Changing Margins to Normal or Extended will eliminate this problem.

## **There are Smears and/or Scratching on Your Printed Media.**

This can appear on paper based media if there is a lot of ink printed quickly, the media gets distorted and as the printheads move over the media, the printheads and the media come into contact with each other.

- Press the **Cancel** key on the front panel otherwise the printheads could get damaged.
- Cancel the print job from your computer application.
- Use HP recommended media.
- Using the Take Up Reel can help solve this problem
- Change the print mode to **Best**.

If the above fails to solve the problem of smears and scratching, change the media you are using to a non-paper based media such as glossy media.

## Solving Media-Handling Problems

### The Front Panel Keeps Indicating that Media Is Misaligned or Incorrectly Positioned

#### Roll media

- The roll may be loaded the wrong way. The media should load over the roll toward you.
- The media may be loaded at an angle. The right-hand edge must be parallel to the perforated line on the printer.

#### Sheet media

- The media may be loaded at the wrong side of the entry slot. It must be loaded with the right-hand edge against the perforated line on the printer.
- The media at an angle. The right-hand edge must be parallel to the perforated line on the printer.
- Pushed or held the media may have been pushed or held back as it is loading. You must hold the media only by the edges and immediately release it when the printer is loading.
- The media may be crumpled or warped or may have irregular edges.
- If you are using hand-cut media, the edges may not form a right-angle or they may be rough. Do not use hand-cut media. Use only purchased sheet media.
- If you cannot make the media's leading edge straight, turn on the skew tolerance feature (Device setup / Skew tolerance). See page 3-43, *Adjusting Skew Tolerance*.

**NOTE:**This feature can skew your print on the page.

### Prints Do Not Feed Out Properly From the Printer

- Make sure the roll cover is completely closed before you print.



## **The Automatic Cutter does not Cut Immediately after a Print has Finished**

- If you have the Take Up Reel accessory installed the cutter is disabled, it will only cut when you perform the unloading procedure see page 3-26, *Unloading Media from the Take Up Reel accessory*.
- Check the Page format / Margins setting. When this is set to Smaller, the printer waits until the next print begins printing so it can create a 10-mm margin between prints or nesting sets.
- If you need to cut the media before the ink-drying time has passed or before the next print begins printing, press **Form Feed and Cut** key on the front panel. Check the ink-drying time and change if necessary (Device setup / Drying time).

## **The Automatic Cutter does not Work**

- The automatic cutter is activated only when roll media is loaded.
- The automatic cutter may be disabled from the front-panel menu. Go to Device setup / Cutter menu and check if the cutter is set to on or off; change it if necessary.
- Your software application may have disabled the automatic cutter. Refer to your software documentation or contact your software vendor for more information.

## The Cutter is Jammed

- Switch the printer off.
- Open the window.
- With you finger and thumb carefully pinch together the cutter assembly plates (1) and move it to the left (2).

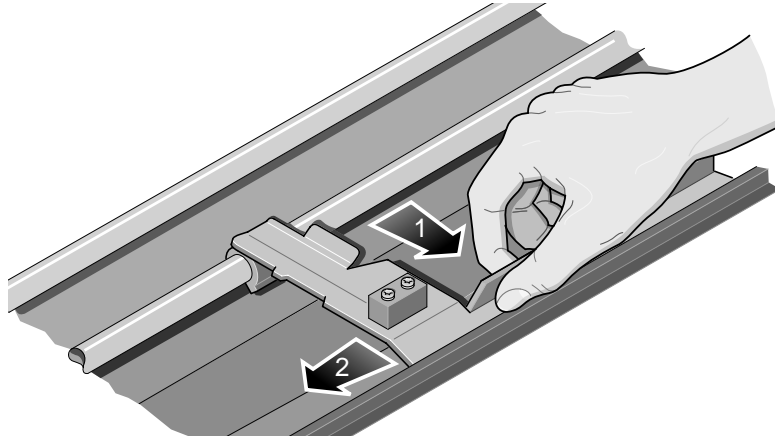

C472378

- If the paper needs to be removed from the printer because it is damaged, perform part of the procedure described on page 3-30, *Removing a Roll from the Printer*.

## A Sheet is Ejected when You Switch On the Printer

- The printer is doing an automatic calibration check. Wait for the STATUS / Ready message and then reload the sheet.

---

# Solving Ink System Problems

## Important

An “ink system” refers to one color. It is made up of the ink cartridge, the printhead and the printhead cleaner.

All three components of an ink system must be used together. The three components are designed to be used together, and information about their use is recorded within the ink system. Failure to use them together could result in poor image quality or a failure of a component at a critical point in printing.

If you transfer a printhead from one printer to another (for example, using transport mode—see page 10-7, *Storing and Moving Your Printer*, you should also transfer the printhead cleaner and the ink cartridge with it.

If you receive an “Out of ink” message and you find that the ink cartridge is empty, replace it *and the associated printhead and printhead cleaner*.

Replacing ink systems must always be done under the control of the Replace Ink Systems button or through specific front-panel prompts. In particular, do not replace components while the printer is powered off, or by opening the window or doors other than as prompted.

## Missing Ink System



MISSING INK SYSTEM  
Install ----->

C4704034

When you first install your printer, or after removing ink systems and then powering on your printer, you will see this message. Press the ↓ key to install the missing ink systems. You will be prompted to install the printheads, printhead cleaners and ink cartridges in turn.

## Ink System Error



INK SYSTEM ERROR  
XXXXXX

C4704034

This message occurs after an earlier report of an error, when you have not fixed the problem. The error code “xxxxxx” indicates the nature of the problem. You will need to press the Replace Ink System key, to gain access to the printheads, printhead cleaners and ink cartridges. See the description of this message on 12-2, *Message Explanations and Actions*.

## Summary of Ink System Defect Messages

<b>Check ink system / Ignore</b>	<p>This message follows one that has notified you of an error. You can either check the ink system (and possibly replace the failed components) now, or ignore the error and continue printing. In the latter case, the quality of printing may be impaired; you may correct the error at a later time.</p> <ul style="list-style-type: none"><li>■ See Checking Ink Systems 11-38.</li></ul>
<b>Head cleaner full</b>	<p>One or more of the printhead cleaners are full of ink. The printer will continue printing but image print quality may be affected, and ink may leak inside the printer and damage it. Replacement of the ink systems affected is recommended.</p> <ul style="list-style-type: none"><li>■ See 11-39, <i>Checking the Printhead Cleaners</i>.</li></ul>
<b>Head cleaner removed</b>	<p>One or more of the printhead cleaners are not detected. Printing has been disabled.</p> <ul style="list-style-type: none"><li>■ See 11-39, <i>Checking the Printhead Cleaners</i>.</li></ul>
<b>Incorrect ink system</b>	<p>The printer has detected an error in the ink system (for example, some component of the ink system may have been removed or reseated in an irregular manner), or the last ink system replacement process did not finish successfully. It may also indicate that not all components of the ink system were replaced at the same time. Printing has been disabled.</p> <ul style="list-style-type: none"><li>■ See 11-38, <i>Checking Ink Systems</i>.</li></ul>
<b>Ink cartridge removed</b>	<p>One or more of the ink cartridges are not detected. Printing has been disabled.</p> <ul style="list-style-type: none"><li>■ See 11-40, <i>Checking the Ink Cartridges</i>.</li></ul>
<b>Ink cartridge valve out</b>	<p>One or more of the ink cartridge valves has popped out during refilling. Printing has been disabled.</p> <ul style="list-style-type: none"><li>■ See 11-34, <i>If there is a Failure after Refilling Printheads</i>.</li></ul>
<b>Ink system at end of life</b>	<p>The printer has detected that one or more components of the ink system have reached the end of their intended lives. You should now replace all three components of those ink systems affected (the printheads, the printhead cleaners and the ink cartridges).</p> <ul style="list-style-type: none"><li>■ See 11-38, <i>Checking Ink Systems</i>, and the general statement about ink systems on page 11-31.</li></ul>
<b>Ink system error</b>	<p>This is a status message that follows an earlier error. The code value in the message indicates the type of error.</p> <ul style="list-style-type: none"><li>■ See the “Ink system error” message.</li></ul>
<b>Mixed ink system</b>	<p>The printer has detected components of different ink systems types (for example, Imaging and UV Pigmented). Printing has been disabled to prevent the printheads from being contaminated.</p> <ul style="list-style-type: none"><li>■ See 11-38, <i>Checking Ink Systems</i>.</li></ul>

<b>Out of ink</b>	<p>One or more of the four ink systems are out of ink. If the last print showed image print quality degradation, replace the ink systems affected.</p> <ul style="list-style-type: none"><li>■ See 11-38, <i>Checking Ink Systems</i>.</li><li>■ Check the ink levels (see 4-9, <i>Monitoring the Ink Level</i>). If there is still a large amount of ink remaining in the ink cartridges, see the message “Printhead failure”.</li></ul>
<b>Printhead alignment cancelled</b>	<p>This message occurs when the alignment routine is cancelled because of a dirty lens cover or a problem with the media.</p> <ul style="list-style-type: none"><li>■ See 11-35, <i>Printhead Alignment Errors</i>.</li></ul>
<b>Printhead alignment error</b>	<p>This message occurs when the printhead alignment procedure has failed, or the printer detects a fault that stops the process from completing. Alignment is the first procedure that prints with the printheads after installation, so some printing problems may be reported as a Printhead Alignment Error. Most alignment errors are due to a fault with the printheads, or problems with the media.</p> <ul style="list-style-type: none"><li>■ See 11-35, <i>Printhead Alignment Errors</i>.</li></ul>
<b>Printhead check cancelled</b>	<p>This message occurs when a printhead check is cancelled because of a dirty lens cover or a problem with the media.</p> <ul style="list-style-type: none"><li>■ See <i>Printhead Checks</i> on page 11-37.</li></ul>
<b>Printhead check error</b>	<p>This message occurs when the printhead check procedure has failed, or the printer detects a fault that stops the process from completing. Most printhead check errors are due to a fault with the printheads, or problems with the media.</p> <ul style="list-style-type: none"><li>■ See <i>Printhead Checks</i> on page 11-37.</li></ul>
<b>Printhead contact error</b>	<p>There is an electrical problem with one or more of the printheads.</p> <ul style="list-style-type: none"><li>■ See the message “Printhead contact error”.</li></ul>
<b>Printhead failure</b>	<p>The ink systems have failed and should be replaced.</p> <ul style="list-style-type: none"><li>■ See the message “Printhead failure”.</li></ul>
<b>Printhead removed</b>	<p>One or more of the printheads are not detected by the printer. Printing has been disabled.</p> <ul style="list-style-type: none"><li>■ See 11-38, <i>Checking the Printheads</i>.</li></ul>
<b>Verify ink system</b>	<p>At power-on, the printer has detected an error in one or more of the ink systems.</p> <ul style="list-style-type: none"><li>■ See 11-38, <i>Checking Ink Systems</i>.</li></ul>

## **If the *Replace Ink System Key* does not Work**

- 1 Make sure the window is closed before you press the **Replace Ink System** key.
- 2 Try pressing **Enter** to clear the previous message.
- 3 The printer may be busy; wait until it has completed the current process. Press the **Cancel** key if you want to interrupt the current process.

## **If Brand New Printheads have Problems**

- 1 Your printer may not detect the ink system that you have installed. Make sure that the protective blue tape and green cardboard have been removed from the printheads.
- 2 Make sure that the electrical contacts on the printheads and the printer carriage are free from ink deposits. (See 11-42, *Cleaning Electrical Contacts*).
- 3 Try reseating the printheads. If you have trouble reseating the printheads, see *If You Have Problems Reseating a Printhead* on page 11-41.

**NOTE:** After you remove or reseat a printhead, the printer will run its automatic printhead alignment procedure.

- 4 Check the ink cartridge to see if it has ink.

If the printheads are functioning, but you are not getting the image quality you expect, see 11-5, *Solving Image-Quality Problems*.

## **If there is a Failure after Refilling Printheads**

If you see the message “Ink cartridge valve out” or “Ink cartridges removed” after printheads have been refilled, it is because an ink cartridge valve has become disconnected or the printer cannot detect an ink cartridge. Printing is disabled.

To fix this problem:

- 1 Press the ↓ key.
- 2 When prompted, open the left door to access the ink cartridges.  
You will see the message “Check ink cartridges / Abort” where the flashing squares indicate which valves to check. See 11-40, *Checking the Ink Cartridges*.

If you don’t correct the error now, you will see the status message “Ink system error”.

## Printhead Alignment Errors

Printhead alignment  
error ■■■□■ --->

C4704034

The printer automatically runs the printhead alignment procedure every time you load, replace or even reseal a printhead, whether it is a new printhead or not. Do not remove the printheads unnecessarily. The routine is also run when media is loaded that is of a different media type from that previously loaded, or after powering on the printer with no media loaded.

The message “Printhead alignment error” is displayed when the alignment procedure has failed or the printer detects a fault that stops the procedure from completing. The alignment procedure is the first time that printheads print after installation, so an initial printing problem may be reported as an alignment error. Most alignment errors are due to:

- Problems with the media.
- Poor printhead start-up.
- Alignment difficulties with the printheads or other printhead malfunction.

You will see the message “Check ink system / Ignore” (see page 11-38, *Checking Ink Systems*). If you choose to check the ink systems you will be given the opportunity to check the printheads that may have caused the problem.

### Media Problems

- 1 Check that the media you are using is clean and has not been printed on. It should be white and opaque. Colored or clear films, media with insufficient opacity, or extremely thick or thin media may be causing the Printhead Alignment Error message.
- 2 Try performing the alignment procedure again (with **Image Quality / Printhead Service / Align Now**) using genuine HP media, or if this is not available, an opaque white media. If the printer now aligns correctly, the problem is probably the media type. (See also 11-35, *Working with Media that cannot be Used for Alignments* below.)
- 3 If the Printhead Alignment Error message still occurs, try recovering the printheads using **Utilities / Service Tests / Recover Printheads**. Then perform the alignment procedure again, using **Image Quality / Printhead Service / Align Now**.

### Working with Media that cannot be Used for Alignments

You can still use media that the printer cannot align on. You will need to use a different type of media to realign the printheads whenever they are removed or resealed.

- 1 Unload the media that is causing problems.

- 2 Load media of a suitable type for calibrating. Make sure you do not change the **Media Type** selection.
- 3 Perform the alignment procedure again (with **Image Quality / Printhead Service / Align Now**).
- 4 Unload the media you used for alignment.
- 5 Reload the media that you want to use for printing, without changing the **Media Type** setting, as that would cause another alignment attempt on the unsuitable media.

If your media is colored or not sufficiently opaque, we recommend disabling the Color Calibration (**Image Quality / Color Calib. / Off**) and Printhead Check (**Image Quality / Printhead Service / Check / Off**) features of your printer, as they may not work correctly.

#### **Poor Printhead Start-Up**

- 1 Perform the Recover Printhead procedure. Select **Utilities / Service Tests / Recover Printheads**.
- 2 Perform the alignment procedure again. Select **Image Quality / Printhead Service / Align Now**.

#### **Other Symptoms or If the Problem is not Fixed Above**

If the Printhead Alignment Error message still occurs, the printer will not be able to print with optimum quality.

- 1 In some cases you may be able to print, but image quality cannot be assured. It may be necessary to reseal or replace your ink system to restore normal performance.
- 2 If the printer will no longer print or you suspect printhead problems, see 11-38, *Checking Ink Systems*.



## Printhead Checks

Your printer makes a printhead check at the frequency set in the **Image Quality / Printhead Service / Printheads Check / Frequency** front-panel menu. This check is also made when you power the printer on, when you explicitly request a check through **Image Quality / Printhead Service / Printheads Check / Now**, or when a pen is installed or reseated. You can disable the frequency checking through **Image Quality / Printhead Service / Printheads Check / Off**. (This does not disable checking at other times).

## Using the *Replace Ink System* Key

The **Replace Ink System** key can be used to check what is wrong with the ink system. If you think you know which part of the ink system is giving trouble (see 11-32, *Summary of Ink System Defect Messages* and the list of messages on page 12-2, *Message Explanations and Actions*), focus on that section, but if you are not sure, try all the steps carefully.

The **Replace Ink System** key lets you access all components of the ink system, even if there is no reported error in any component. (When you start replacing components following a prompt from the front panel, the printer only gives you access to those components for which an error has been detected.)

Use the checklists on page 11-38, *Checking Ink Systems*.

## Checking Ink Systems

Check ink system ->  
Ignore ----->

C4704034

If you see the message “Check ink system / Ignore” you can either proceed with the steps detailed in this section (press the ↑ key) or you can choose to continue printing (press the ↓ key).

If you select “Check ink system” (↑), you will only be asked to check those components for which the printer has detected an error.

If you select “Ignore” (↓), you can continue printing, but the quality of the images produced by the printer may be impaired.

**NOTE:** If an ink system replacement was cancelled, or the printer lost power during a replacement procedure, the machine may indicate that all four ink systems need to be replaced. Removal and reseating the components of each ink system may be all that is required. See 11-41, *If You Have Problems Reseating a Printhead*.

You should only replace the ink systems for which errors are shown on the front panel. If more than one ink system shows an error, follow this procedure for each failing system. Do not remove and reseal printheads too many times, as this can lead to excessive wear on the electrical contacts, causing failures.

If problems persist, see 11-40, *Persistent Ink-System Problems*.

---

### CAUTION

---

If the problem occurred while changing ink system types (from Imaging to UV Pigmented, or vice versa), be extra careful to verify that all ink cartridges match the printheads in type. Installing the incorrect ink cartridge type can result in contamination of both of the ink systems.

- Press the ↑ key for “Check ink system”, if that message is present on the front panel.  
Open the window when indicated.

### Checking the Printheads

Check printhead  
■ ■ □ ■ Abort ->

C4704034

Check the printhead if there is a printhead error reported.

The message “Check printhead / Abort” is displayed. The flashing squares indicate which printheads require checking. If you are unable to fix the errors now, press ↓ to cancel (abort) the procedure.

- Remove the printhead completely from the printer carriage. You should ensure that all four printheads are of the same type—Imaging (part numbers C1806A to C1809A) or UV Pigmented (C1892A to C1895A).

---

**CAUTION**

---

Do not touch, wipe, or attempt to clean the printhead nozzles. This can damage the printhead. Handle the ink systems with care. (See the diagram on page 11-42.)

- Make sure that the protective blue tape and green cardboard have been removed from the printhead.
  - Next, look at the electrical contacts on the side of the printhead and on the carriage. If they are dirty, they should be cleaned (see page 11-42, *Cleaning Electrical Contacts*).
  - Reinsert the printhead. In some cases, if you repeatedly get an error, with the squares continuing to flash, you may need to remove and reinstall all printheads to clear it. See *If You Have Problems Reseating a Printhead* on page 11-41.
- Repeat these steps for any other printheads that need replacing.

Close the window.

### Checking the Printhead Cleaners



Check ■■■\*■  
Close right door

C4704034

If prompted, open the right door to access the printhead cleaners.

The message “Check / Close right door” is displayed. The stars in the message indicate which printhead cleaners must be checked.

- For each printhead cleaner, make sure that it is not overflowing (liquid all the way to the top of the large rectangular hole).
- Check that the part number on the printhead cleaner matches the type of ink system you are using. (The printhead, cleaner and ink cartridge must all be of the same type.) For Imaging Ink Systems the part numbers are C1806A to C1809A, and for UV Pigmented Ink Systems they are C1892A to C1895A.
- Check that the black and white label next to the large rectangular hole has not been completely obscured by ink spray (some spray is normal). If it is, the printer may not be able to detect the printhead cleaner and will report a Head Cleaner Removed message. You will need to replace the entire ink system (printhead, printhead cleaner and the ink cartridge) if this is the case.
- Reinsert the printhead cleaner. Make sure it snaps into place properly. Repeat these steps for any other printhead cleaners that need replacing. Close the right door.

## Checking the Ink Cartridges

Check ink cartridges

■ ■ ■ ■ Abort --->

C4704034

If prompted, open the left door to access the ink cartridges.

The message “Check ink cartridges / Abort” is displayed. The flashing squares indicate which printheads require checking. If you are unable to fix the errors now, press ↓ to cancel (abort) the procedure.

- Check if any of the valves are loose in their holders. If so, this was probably the cause of the problem. Reinsert the valve, and pull on the valve handle gently to make sure it is seated properly. If you have recurring problems with a loose valve, it is probably occurring while the printheads are refilling. You will need to replace the ink system affected.
- If a loose valve was not the problem, remove the ink cartridges that show an error. Check if they are empty by shaking them gently. If it feels as though nothing is moving inside, the ink cartridge is empty and you will need to purchase a new ink system.
- Check that the triangular tab on the ink cartridge valve is not bent or broken. If you are getting an Ink Cartridge Removed message, this may be the cause. If any are bent or broken, you will need to replace your ink system.
- Check that the tubes coming from the ink cartridges are not bent or damaged. If they are, replace the ink system.
- Check that the part number on the ink cartridges matches the type of ink system you are using. (The printhead, cleaner and ink cartridge must all be of the same type.) For Imaging Ink Systems the part numbers are C1806A to C1809A, and for UV Pigmented Ink Systems they are C1892A to C1895A.
- Replace the ink cartridge valves in their correct color-coded locations. The triangular tabs on the valves must be pointing up for the printer to recognize them properly.

Close the left door.

### Persistent Ink-System Problems

If this does not fix the problem:

- If the problem is still present, but not severe enough to prevent printing, the printer’s front panel will indicate that the printer’s image print quality cannot be assured, but you will be allowed to continue printing if you so desire.
- If the problem is serious enough to prevent printing from occurring, please call HP to help resolve the problem. Please have the messages your printer displayed available for the service representative to help speed the diagnosis process.

## If You Have Problems Reseating a Printhead

Replace printhead



C4704034

Check printhead



C4704034

When printheads are installed, in extreme circumstances it is possible that the printer will not recognize them. This will be visible on the front panel with the message “Replace printhead” or “Check printhead / Abort” where one or more of the squares are flashing. Each square represents a printhead, with the flashing ones representing printheads where the printer has detected a problem.

When you reseal or replace a printhead, the flashing filled square changes, for one or two seconds, to an hour-glass. At this point, the printer is testing the printhead. Don't remove or insert another printhead while this test is being done.

- If the test is successful, the hour-glass reverts to its normal non-flashing filled state.
- If the test fails, the hour-glass will change back to a flashing filled square. To correct this, make the following checks:

- 1 Remove all four printheads completely from the printer. On the front panel the displayed message will change to show four flashing lights.
- 2 Look at the electrical contacts on the printhead and carriage. If they are dirty, they should be cleaned (see page 11-42, *Cleaning Electrical Contacts* on page).
- 3 Reinstall each printhead, one at a time; if the flashing squares stop flashing, then the printheads have passed the test. **DO NOT INSERT THE NEXT PRINTHEAD UNTIL THE PRINTER HAS ACCEPTED THE CURRENT ONE.**

If the lights continue flashing and the printheads have been inserted correctly, try reseating them a few more times, by removing the printhead from its stall and then replacing it until it snaps correctly into position.

**NOTE:** Do not leave printheads partly inserted in the carriage; they may be making electrical contact and be the cause of the reseating problem, as you try to reseal other printheads.

If the printer still refuses to accept your printheads, try replacing the indicated ink system (see 11-38, *Checking Ink Systems*) or call HP for assistance.

## Cleaning Electrical Contacts

The printer prints by firing tiny drops of ink onto the media. This is controlled by electrical signals that are sent from the printhead carriage to the printhead through electrical contacts. During normal printing operations, it is possible for ink to get spilt onto these electrical contacts. Ink can also be spilt onto them when printheads are loaded into the carriage.

To clean the electrical contacts, you will need some cotton swabs, lint-free cloths, soft tissues or napkins. You will also need some clean water, preferably distilled. Avoid using dry cotton swabs, as lint from the cotton may leave debris or other contaminants; avoid also using dry cloths, as they may scratch delicate surfaces.

Alternatively, you can use a suitable cleaning kit, for example, the HP C6247 Ink Cleaner—follow the supplied instructions.

- 1 Prepare a clean cotton swab by dampening it with distilled water. Rotate the end of the swab between your fingers to pack the cotton and to remove excess water.

If you are using a cloth or tissue, make it slightly damp, but not so wet that it drips or disintegrates.

If you need to clean more than one ink system, use fresh swabs for each one, to avoid cross-contamination.

**Do not power off the printer.**

---

### CAUTION

---

Never drip water into the printer.

- 2 To clean the electrical contacts on the printhead, remove it from its stall and, holding it by the cap, turn it as shown below.

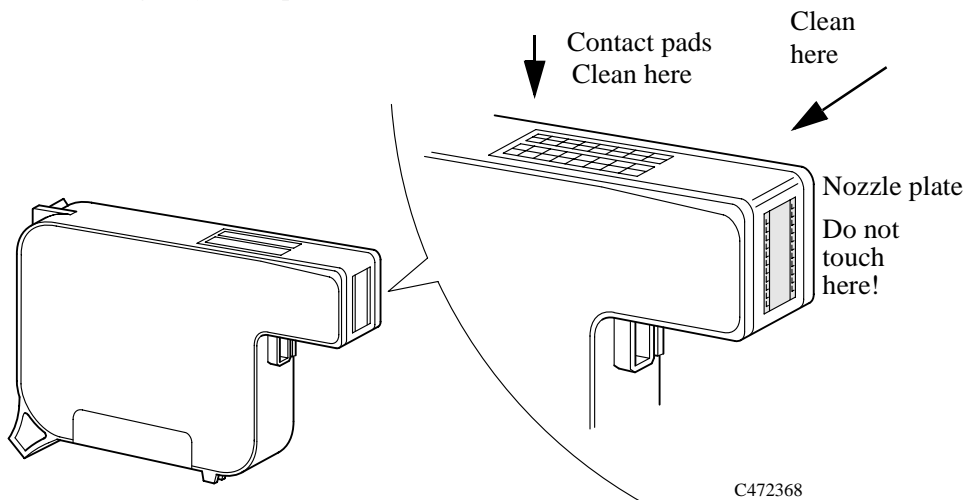

C472368

---

**CAUTION**

---

Do not touch, wipe, or attempt to clean the printhead nozzles (on the right-hand side in the diagram above). This can damage the printhead. Handle the ink systems with care.

- Using damp cotton swabs, clean the electrical contact pads (the copper strip), especially where it bends down towards the nozzle plate. Wipe the contact pads very gently towards the cap end of the printhead, away from the nozzle plate. If you are using a cloth or tissue, use gentle pressure to avoid damaging the contacts. If you are using the cleaning kit, wipe the printhead cleaner pads as shown below:

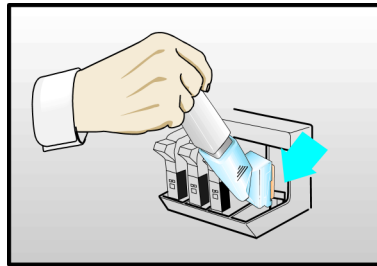

C472380

- Using damp cotton swabs, clean the electrical contact pads on the printhead carriage (indicated by the arrow in the diagram).

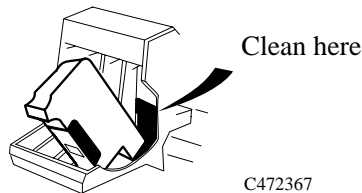

C472367

If you are using the cleaning kit, wipe the printhead as shown below:

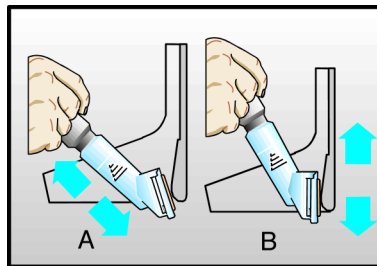

C472381

- Wait until all the cleaned parts are dry.

Reinstall the printhead.

## Clearing a Media Jam

- 1 If the front panel displays:

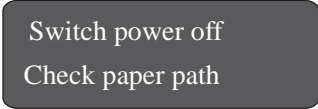

Switch power off  
Check paper path

C4704034

- 2 or:

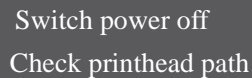

Switch power off  
Check printhead path

C4704034

switch the printer OFF at the power switch at the back of the printer, open the window, and lower the media lever.

- 3 Carefully move the printhead carriage out of the way - if possible all the way to the enclosed area on the left or the right. Which way you are able to move it depends on where the media is jammed. If the printer was in the process of cutting media at the time of the jam, the cutter carriage will be attached to the printhead carriage and will move with it.

---

### CAUTION

---

**When moving the printhead carriage, touch only the black plastic parts.**

- 4 Carefully remove any of the jammed media which you can easily lift up and out from the top of the printer.
- 5 Carefully pull the rest of the roll or sheet down and out of the media entry slot.
- 6 Lower the window and the lever and switch on the printer. Press the Form Feed and Cut key to eject any pieces of media that are still in the media path.

**NOTE:** Depending on the status of the printer when the media jam occurred, it may check the ink system components now - see chapter 4, *Working with Ink Systems*, for more information.

- 7 Reload the media as normal - see page 3-13, *Loading Roll Media*. If you are using roll media you may need to trim the edge first.



# Solving Communication Problems

## If there is a Problem Communicating between Your Computer and the Printer

### Some symptoms of a communication problem are:

- The front-panel Receiving light does not come on.
- The front-panel display does not show STATUS / Receiving.
- Your computer displays an error message when you are trying to print.
- Your computer or printer “hangs” (stays idle) while communication is taking place.
- Your printed output shows random or inexplicable errors (misplaced lines, partial graphics etc.)

### Items to start checking are:

- Have you selected the correct interface port in your software?
- Does the printer work correctly when receiving files from other software?
- If the printer is connected to a network, try using it when connected directly to your computer.
- If your printer is connected to your computer through any other intermediate devices, such as switch boxes, buffer boxes, cable adapters, cable converters etc., try using it when connected directly to your computer.
- Try another interface cable. For details of supported cables, see page 13-11, *Interface Cables*.

## Solving Problems with Image Position or Content

If you don't find the solution to the problem here, other sources of help are:

- The documentation supplied with the driver that you are using to manage the output from your software application to the printer.

---

### 2500CP Only

For example, the on-line and printed documentation included in the following drivers supplied with your printer

- HP DesignJet PostScript® drivers for Power Macintosh® and Macintosh® (QuickDraw™)
- HP DesignJet PostScript® drivers for Microsoft® Windows™ applications.
- The documentation supplied with your application software.

### If the Print is Completely Blank

- If the front-panel graphics language setting is Automatic (the default), try the other settings: (PostScript for a PostScript file, HP-GL/2 for an HP-GL/2 file etc.) and send the file again.

### If the Output Contains Only a Partial Print

- Did you press **Cancel** or **Form Feed and Cut** before all the data was received by the printer? If so, you have ended the data transmission and will have to print the page again. (You normally don't need to press **Form Feed and Cut** to unload the print.)
- The I/O Setup / I/O Timeout setting may be too short. From the front-panel menu you can increase the I/O Timeout setting to a longer period and then send the print again.
- The file may be too large for the printer's memory. You can install extra memory in your printer, see *Install Memory Expansion Modules (Optional)* in the Setup Guide for more information.
- There may be a communications problem between your computer and the printer. Check your interface cable.
- Check to make sure that your software settings are correct for your current page size (e.g., long-axis prints).
- If you are using network software, make sure it has not timed out.
- See also under *If the Image is Clipped* below.

## If the Image is Clipped

- This normally indicates a discrepancy between the actual printing area on the loaded media and the printing area as understood by your software. For general advice on printing areas and page size, see chapter 5.
- Check the actual printing area for the media size you have loaded. printing area = media size minus margins. For media size and margins, see page 13-9.
- Check what your software understands to be the printing area (which it may call “printable area” or “imagable area”). For example, some software applications assume standard printing areas that are larger than those used in this printer.
- Check that the orientation of the media is the same as that assumed by your software. The front-panel Page format / Rotate option changes the orientation of a graphic and, on roll media, the orientation of the page. It is possible that a rotated image on roll media may be slightly clipped in order to retain the correct page size, as explained on page 5-7.
- You may have asked to rotate the page from portrait to landscape on media that is not wide enough, for example a D/A1-size page rotated on a D/A1-size roll.
- If necessary, change the printing area in your software.
- The file may be too large for the printer's memory. This is the case if the front panel displays “Out of memory - data was lost”. See page 13-18, *Ordering Accessories* for details of memory expansion modules.

## If a Long-Axis Print Is Clipped

- Does your software support long-axis prints?
- Have you specified an appropriate media size in your software?
- Unless it is a PostScript file, make sure that the printer's Page format / Size is set to Inked area.

## **If the Entire Image is in One Quadrant of the Correct Printing Area**

- Is the page size configured in the software too small?
- Are you sure that your software doesn't believe the graphic to be in one quadrant of the page?

Otherwise, this indicates an incompatibility between the software and the printer:

- Is your software configured for this printer? For general advice, see *Set Up Your Software* in the Setup Guide. For advice specific to your software, see either the documentation supplied with the driver or any Software Application Notes supplied with your printer.
- If you still haven't found the solution, try changing the printer's Graphics Language setting on the front panel (Device setup / Lang).

## **If the Image Is Unexpectedly Rotated**

- Check the front-panel Page format / Rotate setting. See page 5-4, *Do You Need to Adjust the Page Size in the Front Panel?*
- For non-PostScript files: If Queueing and Nesting are both ON, pages may be automatically rotated to save media. See page 5-15, *Rotating an Image from the Front Panel*
- For an explanation of rotation for PostScript files, see page 5-15, *Rotating an Image*.

## **If the Print Is a Mirror Image of Your Graphic**

- Check the front-panel Page format / Mirror setting.

## **If the Print Is Inaccurate**

- If you notice problems with accuracy, print the Service Config print, as explained on page 8-6, *Recalibrating the Printer for Accuracy*, to see if the printer needs to be recalibrated.
- Try running the image quality check to determine if the problem is connected to the ink system. See 11-5, *Solving Image-Quality Problems*

## **If the Print is Distorted or Unintelligible**

- The interface cable between your computer and the printer could be faulty. Try another cable to see if the problem is corrected.
- If you have connected your computer to the parallel port on the printer, make sure you are using a genuine HP parallel interface cable.
- If the front-panel graphics language setting is Automatic (the default), try the other settings:  
(PostScript for a PostScript file, HP-GL/2 for an HP-GL/2 file etc.) and send the file again.
- Depending on the software, drivers and RIPs you are using with your printer, there will be different solutions to solving this problem. Refer to the Vendor's User Documentation for details.

## **If One Image Overlays Another on the Same Sheet**

- The I/O Setup / I/O Timeout setting may be too long. From the front-panel menu decrease the setting and print again.

## **If Pen Settings Seem to have No Effect**

- Either you have changed them in Pen settings / Define palette but forgotten to select that palette in Pen settings / Palette,
- or you expected the software-driven pen settings but in the front-panel Pen settings / Palette is not set to Software.

## **If the Printer Produces a Black and White Print When You Expected a Color Print**

- Check the front-panel Color/Mono setting, and the equivalent setting in your software.

## **If the Printer has Printed a Different Print than the One You were Expecting**

**One possibility is that you have accidentally initiated one of the printer's internal prints:**

- The printhead Alignment Print. (A small pattern of colored squares without text.) This is printed automatically every time you replace, or even reseal a printhead.
- The Current Configuration Print. This is printed by simultaneously pressing the two arrow keys on the front-panel.
- The Image Quality print. This is printed from the Utilities / Service tests/ Image quality print menu.
- The Service print. This provides information needed for printer servicing, such as the current configuration, operating conditions (temperature and humidity), ink levels, and other statistics about printer usage.

**Or you may have initiated one of the following Internal prints which are printed from the Internal prints menu:**

- PostScript demo.
- PostScript config.
- The Fonts print.
- The HPGL/2 Configuration print
- The Printer Usage Information print
- The menu print.
- The HP-GL/2 Palette.

## Solving Front-Panel Problems

### If the Replace Ink System Key Does Not Work

- Make sure the window is closed before you press **Replace Ink System**.
- The printer may be busy. Wait until it has completed the current process.
- Press Enter to clear the previous message.

### If None of the Front-Panel Keys Work

- The printer may have been idle for some time and reverted to standby mode. Momentarily press the standby switch to restore the front-panel keys and menu display.
- At the power switch at the back of the printer, turn the printer off and then on again. If the problem persists, have your printer serviced.

### If Page Format/Rotate does not Work

- The file may be too large for the printer's memory. This is the case if the front panel displays "Out of memory - data was lost". See page 13-18, *Ordering Accessories* for details of memory expansion modules.
- The printer cannot rotate raster images (except for PostScript files). If your non-PostScript file contains raster data (typically, images with heavy area fill and shading that you have scanned into your software) you will not be able to rotate the print.

### If a Display Message will not Clear

- Look up the message in chapter 12, *Front-Panel Messages*. The message description may help you understand and resolve the problem.
- If looking up the message did not help, press Enter. If that does not work, turn the power off, then on again. If the message still displays, have the printer serviced. If the message says "System Error" and has an alphanumeric code, refer to the next explanation.

## **If a “System Error” Message Is Displayed**

Press Enter. If the message does not clear:

- 1** Turn the printer off, then on again to try to clear the error message.
- 2** If the message is still displayed, record the whole alphanumeric code. Report the code to the service technician; knowing the code number will help the technician resolve the problem.

## **If an “Out Of Memory/Data Was Lost” Message Is Displayed**

- The current file is too large for the printer’s memory.

## **File Size and Memory Usage**

There is no direct relationship between file size on your computer and memory used in the printer to print that file. In fact, because of file compression (and general complexity) it is often impossible to estimate how much memory will be used.



## Take Up Reel problems

### **Take Up Reel Does Not function**

- You may have a power problem. Check the power cable is connected and that there is power available at the socket.
- Check the ON/OFF switch is in the ON position at the back of the Take Up Reel.
- Check the Spindle Lever, it should be closed.
- Check the sensor cable from the right hand assembly is connected correctly.
- Check the sensor operates correctly by placing a sheet of paper over the sensor.
- Defective Right Hand Take Up Reel Assembly.
- Defective Sensor Assembly.

### **Media Skewed on Take Up Reel.**

- Media not loaded straight on the Take Up Core
- Media Weight is not the same width as the media being used.
- Take Up Core is not the same width as the media being used
- Media Weight is not fully inserted.
- Take Up spindle is not installed correctly.
- Left and Right Hand Take Up Reel Assemblies not installed correctly
- Ensure that there are no objects in the Base Tray Assembly

## Solving Miscellaneous Problems

### If the Printer does not Print

- You may have a power problem. If there is no activity at all from the printer, and no lights on the front panel, check that the power cable is connected correctly and that there is power available at the socket.
- If you are using a Macintosh and the print job does not print, ensure the printer language is set to Postscript or Automatic. See page 8-8, *Changing the Graphics Language*.
- You may have a problem with your application driver. Is your software configured for this printer? For general advice, see the Setup Guide. For advice specific to your software, see either the documentation supplied with the driver or the Software Application Notes supplied with your printer.
- If you have connected your computer to the printer's parallel port and tried to print a binary-encoded PostScript file it will not print. The parallel port will only accept ASCII-encoded PostScript print files. The front panel will display the message "Error processing job / Flushing rest of job". Press ↓ on the front panel to delete the print file. Connect your computer to the JetDirect Print Server and send the print file again.
- The file may be too large for the printer's memory. This is the case if the front panel displays "Out of memory - data was lost". Look on your computer screen for any error message; some drivers allow you to choose a different printing mode and try to send the file again.
- If you continue to have problems, see page 11-56, *Getting Help*.

### If the Printer Seems Too Slow

- Did you specify Photo Print mode level on the front panel? Photo quality prints are produced more slowly.
- Did you specify the right media type when loading the media? For details of front-panel media types, see page 3-4, *Supported Media Types*. To find out the printer's current media type setting, see page 8-5.
- Are you using the printer with the Appletalk serial port on Macintosh? It is normal for the Appletalk port to be slow. Consider using the Ethertalk interface to connect your printer to your Macintosh.

## **If the Printer Waits Too Long to Print a Nest**

- Change the Nest wait setting. See page 7-15.

## **If the Bail (Black Metal Bar) does not Lower All the Way**

- If the bail (the black metal bar just inside the printer's window) will not lower all the way, check for obstructions underneath it.
- Make sure the cutting carriage is pushed all the way to the left.

## **The Media coming from the Printer is Fed Back into the Printer causing a Media Jam.**

- Lower the media lever and pull the media which has been fed back into the printer until it is released.
- Go to Utilities/Move Media press the ↓ key to move the “media backwards”. This will unblock the printer and you will be able to retrieve your media.
- If the media is damaged, cut and reload the media as described on page 3-13, *Loading Roll Media*.

## Getting Help

### About HP Customer Care

As your strategic support partner, we make it our business to help keep your business running smoothly. HP Customer Care offers award-winning support to ensure you get the most from your HP DesignJet.

HP Customer Care provides comprehensive, proven support expertise and leverages new technologies to give customers unique end-to-end support. Services include setup and installation, troubleshooting tools, warranty upgrades, repair and exchange services, phone and Web support, software updates, and self-maintenance services. To find out more about HP Customer Care, please visit us at:

**[www.hp.com/go/support](http://www.hp.com/go/support)**

### What to Do Before You Call

- 1 Review the troubleshooting suggestions in this chapter:
  - In the relevant driver documentation supplied with this printer (for users sending PostScript files or those using Microsoft Windows).
  - If you have installed third party software drivers and RIPs refer to that user documentation.
  - In any relevant Software Application Note supplied with this printer.
- 2 If the problem is image quality, print out the image quality print; see page 2-12, *Printing Other Internal Prints* and page 11-5, *Solving Image-Quality Problems*.
- 3 Print the Image Quality Print to determine if the problem is due to printhead errors or printer hardware problems; see page 11-8, *Printing the Image Quality Print*.
- 4 If the problem appears to be related to your software application, first contact your software vendor.
- 5 If you still have difficulty, refer to the HP Support Services booklet shipped with this printer. This document contains a comprehensive list of various support services available to help solve printer problems.
- 6 If you do call one of the Hewlett-Packard offices, please have the following information available to help us answer your questions more quickly:
  - The printer you are using (the product number and the serial number, found on the label at the back of the printer).

- The computer you are using.
- Any special equipment or software you are using (for example, spoolers, networks, switch-boxes, modems, or special software drivers).
- The cable you are using (by part number) and where you purchased it.
- The type of interface used on your printer (parallel, or network).
- The software name and version you are currently using.
- If the problem is a software error it will have a error number; record the error number and have it ready.
- If possible print out the following reports. See page 2-12, *Printing Other Internal Prints* and fax them to the support center helping you:
  - Usage report
  - Postscript config.
  - Service print.



---

# Front-Panel Messages

# *12*

---



Message Explanations and Actions 12-2

## Message Explanations and Actions

This is a list of the messages in the front-panel display. If an action is needed, it is shown in italics in the Explanation and Action column. The messages are listed in alphabetical order.

Message	Explanation and Action
Accessing head cleaners	The printer is moving the platform that contains the printhead cleaners to a place where you can access them. <i>Wait for a few seconds until this operation has finished.</i>
Accessing printheads	The printer is moving the carriage that contains the printheads to a place where you can access them. <i>Wait for a few seconds until this operation has finished.</i>
Action unavailable Entry being printed	A print is being printed and you have requested to move, delete or modify the number of copies through the queue management menu. You cannot change the current entry until the print has finished. <i>Wait until the print has finished.</i>
Calibrate error Continue→	The calibration print was loaded incorrectly and it could not be measured. <i>Press ↓ to continue, then reload the print for measurement. Follow front panel instructions.</i>
Calibrate Yes → Color No →	You are using sheet media and color calibration is on. The printer is asking you if you want to calibrate the color for the loaded media. <i>Press ↑ for yes. Press ↓ for no.</i>
Calibration done Continue→	Accuracy calibration is complete. <i>Press ↓ to continue.</i>
Cancelled Continue→	You have just cancelled the last print or function. <i>Press ↓ to continue.</i>
Check ■■*■ Close right door	The printer has detected an error in the printhead cleaners indicated by the stars. <i>Reseat (do not replace) the indicated cleaners. When you have done so, close the right door of the printer. See 11-39, Checking the Printhead Cleaners.</i>



Message	Explanation and Action
Check ink cartridges  Abort →	The printer has detected an error in the cartridges indicated by the empty squares. <i>Reseat (do not replace) the indicated cartridges or press the ↓ key to terminate the procedure. In this case, you will not be able to print, and you may later resume checking the ink system by pressing the <b>Replace Ink System</b> button. See 11-40, Checking the Ink Cartridges.</i>
Check ink system→ Ignore→	After an error has been detected in the ink system, you are given the chance to check it. <i>Press ↑ to check the ink system right now. The printer will indicate which ink systems are affected.</i> <i>Press ↓ to ignore the error and continue printing. In this case the image quality cannot be assured.</i> <i>To fix any errors, see the check-lists in 11-38, Checking Ink Systems.</i>
Check printheads  Abort →	The printer has detected an error in the printheads indicated by the empty squares. The printhead can be replaced, but you should replace all components of the failing ink systems as soon as possible. <i>Reseat (do not replace) the indicated printheads or press the ↓ key to terminate the procedure. In this case, you will not be able to print, and you may later resume checking the ink system by pressing the <b>Replace Ink System</b> button. (If you have persistent problems, see If You Have Problems Reseating a Printhead 11-41.)</i>
Close left door to continue	You opened the left door while the printer was busy, or you have finished installing the ink cartridges. <i>Close the left door to continue.</i>
Close roll cover Continue→	<i>Rewind the media to take up any slack in the roll, close the roll cover, then press ↓ to continue.</i>
Close window to continue	You have finished installing the printheads. <i>Close the window to continue.</i>
Create pattern→ Measure pattern→	<i>Press ↑ to create the pattern for automatic calibration.</i> <i>Press ↓ to measure the pattern for automatic calibration.</i>
Disk error Continue→	(HP DesignJet 2500CP only) An error on the hard disk has been detected. <i>Press ↓ to continue.</i>

Message	Explanation and Action
Edge not found Reload media	<p>The printer could not find edge of media during loading procedure.</p> <p><i>Check the leading edge of the media for unevenness or tears; cut a straight edge, if necessary, and reload. Be sure to position the right edge along the perforated line on the entry platen when loading.</i></p>
Error processing job Flushing rest of job→	<p>An error was encountered while the print was being processed. The print has been lost.</p> <p><i>Press ↓ to delete the print.</i></p>
Fatal disk error Continue→	<p>(HP DesignJet 2500CP only) An error on the hard disk has been detected.</p> <p><i>Press ↓ to continue. Retry the operation by cycling the power. If the problem persists, servicing the printer is advised.</i></p>
Head cleaner full ■■■□■→	<p><b>Either:</b> After finishing printing, the printer has detected that one or more of the printhead cleaners are full of ink. The squares that are flashing indicate the head cleaners that are full.</p> <p><i>Press ↓ to continue. The message “Check ink system→ / Ignore→” is displayed. If you press ↓ again to continue, you may still be able to print again, but the ink in the head cleaner may overflow and the print quality of your images may be affected. To fix the problem, select ↑ to check the ink system; see 11-38, Checking Ink Systems.</i></p> <p><b>Or:</b> In the ink system replacement process, one or more of the printhead cleaners have not been replaced at the same time as the corresponding printheads. The squares that are flashing indicate the head cleaners that are full.</p> <p><i>Press ↓ to continue. You may still be able to print again, but image print quality may be affected, as indicated by a subsequent message. See 11-38, Checking Ink Systems.</i></p>
Head cleaner ink may overflow→	<p>One or more of the printhead cleaners are full of ink, and the ink may overflow.</p> <p><i>Press ↓ to continue. Image print quality may be affected, and ink may leak inside the printer and damage it. Replacement of the ink systems affected is recommended. To fix problems with the ink system, see 11-38, Checking Ink Systems.</i></p>
Head cleaner removed ■■■□■→	<p>The printer has detected that one or more printhead cleaners have become dislodged or the printer cannot detect them, as indicated by the flashing squares. Printing is disabled.</p> <p><i>Press ↓ to check the failing head cleaner. You should reseal the head cleaners immediately; see 11-39, Checking the Printhead Cleaners. If this does not solve the problem, you will have to replace the entire ink system (printhead, printhead cleaner, and ink cartridge) using the <b>Replace Ink System</b> key.</i></p> <p><i>If you don’t correct the error now, you will see the status message “Ink system error” described on page 12-7.</i></p>

Message	Explanation and Action
Image quality not assured→	<p>This message appears after the printer finds an error in the ink system. One or more of the ink systems have passed their specified life, one or more of the printhead cleaners are full of ink, or one or more of the printheads has failed an electrical test, or an alignment or nozzle check.</p> <p><i>Press ↓ to continue. You may continue printing, but you may not get your usual image print quality. To fix problems, see 11-38, Checking Ink Systems.</i></p>
Imaging inks YES→ installed NO→	<p>After you have finished installing a new ink cartridge, you are asked to confirm that you have changed the type of ink cartridges from UV Pigmented to Imaging.</p> <p><i>Press ↑ to confirm that you have changed the ink cartridges from UV Pigmented to Imaging.</i></p> <p><i>Press ↓ to indicate that you have not changed the ink cartridges from UV Pigmented to Imaging. You will then be given the opportunity of replacing the incorrect ink cartridges by the correct ones.</i></p>
Incorrect ink system ■ ■ □ ■ →	<p>After you used the Replace Ink System procedure, which was cancelled by a time-out or aborted (see Checking Ink Systems 11-38), the printer has detected that one or more of the ink systems are still faulty or have not been fully replaced, as indicated by the flashing squares. This message also appears if the printer believes that a component is incorrect; you must then confirm that the ink system is indeed correct, or rectify the error.</p> <p><i>Press ↓ to continue, to replace the ink systems. Printing will be disabled. You should replace the faulty ink systems immediately; see page 11-38, Checking Ink Systems.</i></p> <p><i>If you don't correct the error now, you will see the status message "Ink system error" described on page 12-7.</i></p>
Initializing new ink system	<p>In the ink system replacement process, you have swapped an Imaging ink system for a UV Pigmented ink system, or vice versa. The printer will reinitialize and prepare to print with the new ink system. (This message only applies to firmware revision levels A.02.08 or higher.)</p> <p><i>Wait until the new ink system has been initialized.</i></p>

Message	Explanation and Action
Ink cartridge removed ■■■■→	<p>The printer has detected that one or more ink cartridges have been removed or cannot be detected, as indicated by the flashing squares.</p> <p><i>Press ↓ to check the failing ink cartridge. Printing has been disabled. You should reseal the ink cartridge immediately; see 11-40, Checking the Ink Cartridges. If this does not solve the problem, you will have to replace the entire ink system (printhead, printhead cleaner, and ink cartridge) using the <b>Replace Ink System</b> key.</i></p> <p><i>If you don't correct the error now, you will see the status message "Ink system error" described on page 12-7.</i></p>
Ink cartridge valve out ■■■■→	<p>The printer has detected that one or more of the ink cartridge valves (as indicated by flashing squares) has popped out during refilling.</p> <p><i>Press ↓ to check the failing ink cartridge. You should reseal the valves immediately; see 11-40, Checking the Ink Cartridges. If this does not solve the problem, you will have to replace the entire ink system (printhead, printhead cleaner, and ink cartridge) using the <b>Replace Ink System</b> key.</i></p>
Ink system at end of life ■■■■→	<p>The printer has found that an earlier "Out of ink" error has not been corrected. One or more components of the ink system, as indicated by flashing squares, have reached the end of their intended lives. You should now replace all three components of those ink systems affected (the printheads, the printhead cleaners and the ink cartridges). See the general comments about ink systems on page 11-31.</p> <p><i>Press ↓ to continue. Image print quality may be affected. Replacement of the ink systems affected is recommended. To fix problems with the ink system, see 11-38, Checking Ink Systems.</i></p>
Ink system at end of life. Retry→	<p>The printer has detected that one or more components of the ink system have reached the end of their intended lives. You should now replace all three components of those ink systems affected (the printheads, the printhead cleaners and the ink cartridges). See the general comments about ink systems on page 11-31.</p> <p><i>Press ↓ to replace the erroneous ink systems. See 11-38, Checking Ink Systems.</i></p>

Message	Explanation and Action
INK SYSTEM ERROR xxxxxx	<p>The printer has detected an error in the ink system, as shown in earlier messages. Printing will be disabled until the error has been corrected. If more than one error is pending, the one with the highest number, corresponding to the most severe error, will be displayed.</p> <p>Possible error codes (xxxxxx) are:</p> <ul style="list-style-type: none"> <li>• 58.... See the message “Incorrect ink system”</li> <li>• 65.... or 66.... See the message “Printhead failure”</li> <li>• 67.... See the message “Printhead contact error”</li> <li>• 72.... See the message “Ink cartridge removed”</li> <li>• 73.... See the message “Head cleaner removed”</li> <li>• 74.... See the message “Printhead removed”</li> <li>• 88.... See the message “Mixed ink system”.</li> </ul> <p><i>Press the <b>Replace Ink System</b> key to replace the erroneous ink systems in order to print with your printer again. See 11-38, Checking Ink Systems.</i></p> <p><i>Press the <b>Enter</b> key to access the main front panel menus.</i></p>
Install complete	<p>Ink system replacement has been completed successfully.</p> <p><i>Resume normal operations.</i></p>
Lift lever after aligning	<p>You have lowered the media lever to align the media with the entry platen.</p> <p><i>Lift the lever at the right edge of the paper path on the printer when you’ve finished aligning the roll media as instructed.</i></p>
Lift lever to continue	<p>The media lever was lowered while the processor was busy.</p> <p><i>Lift the lever at the right edge of the paper path on the printer.</i></p>
Load arrow edge print side down	<p><i>Remove the accuracy calibration print, turn it so that the edge with the arrows printed on it is print-side down, then load that edge into the printer.</i></p>
Load cancelled Remove media	<p>The <b>Cancel</b> key was pressed while media loading was in progress.</p> <p><i>Remove media.</i></p>
Load error Remove media	<p>Media was inserted with the media lever raised.</p> <p><i>Lower the lever and reload the media.</i></p>
Load media for calibration	<p><i>Load media to proceed with calibration.</i></p>
Load media to align printheads	<p><i>Load media to proceed with printhead alignment.</i></p>

Front-Panel Messages  
Message Explanations and Actions

Message	Explanation and Action
Load media to check printheads	The printer is telling you to load media so it can perform the printhead check. <i>Load media to proceed with printhead check.</i>
Load sheet for calibration	The printer is ready to perform the accuracy calibration procedure, but media is not present. <i>Load media to continue.</i>
Lower lever	<i>Lower the lever at the right of the printer.</i>
Lower lever Remove media	<i>Lower the lever at the right of the printer and remove the media.</i>
Lower window to continue	The window was opened while the printer was busy. <i>Close the window to continue.</i>
Media too small	You may have sent a print file that is too large for the media loaded; the print may be clipped. <i>Press <b>Cancel</b> if the media is unsuitable, and reload with appropriate media.</i>
Media too small for calibration→	The media you loaded for printhead alignment or a printhead check is too small. The procedure has been cancelled. You may continue printing without calibrating the printer, but the image quality is not assured. <i>Press ↓ to continue. If you want to complete the interrupted procedure, reload with appropriate media (A3-size paper or larger, in landscape orientation) and redo the procedure:</i> <ul style="list-style-type: none"><li>• Use <b>Image quality / Printhead service / Align now</b> for printhead alignment.</li><li>• Use <b>Image quality / Printhead service / Printheads check / Now</b> for a printhead check.</li></ul>
MIO error Communication break	The flow of data from the computer to the printer stopped prematurely (for example, the computer may have been shut down before all data was sent). <i>Press <b>Enter</b> to clear the message from the front panel display.</i>
MIO error handshake	You configured the modular interface incorrectly. <i>Press the <b>Enter</b> key to clear the message from the front panel. Check the handshake settings in the printer's front panel, in the hardware configuration, and in your application software configuration to make sure they are compatible with one another.</i>
Mispositioned Reload roll	The roll media is mispositioned. <i>Remove and reload the roll.</i>

Message	Explanation and Action
Mispositioned Reload sheet	The sheet media is mispositioned. <i>Remove and reload the sheet.</i>
MISSING INK SYSTEM Install→	One or more ink systems are missing. <i>Press ↓ or the <b>Replace Ink System</b> key to install the ink systems in order to print with your printer.</i>
Mixed ink system □■■■→	At power-on or after the ink systems have been serviced, the printer has detected components of different ink system types (for example, Imaging and UV Pigmented). Printing will be disabled until the ink systems are all of the same type. The flashing squares indicate which ink systems need checking. The error may be because the printhead, printhead cleaner and ink cartridge within an ink system are not all of the same type (UV Pigmented or Imaging) or that entire ink systems are of different types. <i>Press ↓ to continue, to check the ink systems. See 11-38, Checking Ink Systems.</i>
MIXED INK SYSTEM 88xxxx	The printer has earlier detected components of different ink system types (for example, Imaging and UV Pigmented). Printing will be disabled until the ink systems are all of the same type. The error code “88xxxx” indicates a mixed ink system error. <i>Press the <b>Replace Ink System</b> key to replace the erroneous ink systems in order to print with your printer again. You can press the <b>Enter</b> key to access the main front-panel menu.</i> <i>See 11-38, Checking Ink Systems.</i>
No code for UV inks Continue→	The printer does not have the correct firmware for the HP DesignJet CP ink system UV currently installed. <i>(This message only applies to firmware revision levels A.01.xx.)</i> <i>Press ↓ to continue, and reinstall the HP DesignJet CP Ink System (Imaging ink system) back into the printer.</i> <i>Access the menu <b>Utilities / Statistics / Code rev</b> to confirm the firmware revision present. If you have a code revision like A.01.xx, you need to upgrade your firmware to code revision A.02.08 or higher to use the HP DesignJet CP Ink System UV.</i>
Open left door to access ink cartrg.	You are doing an ink system replacement. <i>Open the left door to access the ink cartridges.</i>
Open right door to access head cleaners	You are doing an ink system replacement. <i>Open the right door to access the printhead cleaners.</i>

Message	Explanation and Action
Open window to access printheads	You are doing an ink system replacement. <i>Open the window to access the printheads.</i>
OUT OF INK ■■■■□ →	The printer has detected that the amount of ink in the ink systems indicated by one or more flashing squares, is below acceptable limits for satisfactory printing. <i>Press ↓ to check the indicated ink systems. See 11-38, Checking Ink Systems. You will be prompted to change the kit or to ignore the error and continue printing. If there is still a large amount of ink remaining in the ink cartridges, see the message Printhead failure on page 12-12.</i>
Out of memory Data was lost	The current file is too large for the printer's memory; the printer has run out of disk space for processing the file. <i>To print files of this size, you may need to install more memory to your printer.</i>
Press ENTER when done	The printer is waiting for you to confirm an action or selection. <i>When you have taken the appropriate action press the <b>Enter</b> key.</i>
Printhead alignment cancelled→	The printhead alignment procedure has failed, or the printer has detected a fault that stops the procedure from completing. Subsequent messages will explain the error further: <ul style="list-style-type: none"><li>■ “Replacement of lens cover recommended”—<i>You should check the section on replacing lens covers on page 10-3, Lens Maintenance.</i></li><li>■ “Media too small for calibration”—<i>The roll that is loaded is not wide enough for the calibration to be done. It must be at least A3 size. You should load appropriate media and repeat the procedure again, using <b>Image Quality / Printhead Service / Align Now</b>. If you use sheet media that is too small, the printer will reject the media and prompt you to load new media.</i></li></ul> <i>Press ↓ to continue. You may continue printing, but you may not get your usual image print quality. To fix problems with the ink system, see 11-38, Checking Ink Systems.</i>
Printhead alignment error ■■■□■→ or Printhead alignment error →	The printhead alignment procedure has failed, or the printer has detected a fault that stops the procedure from completing. The squares that are flashing indicate the ink systems that have failed. If the message contains no squares, the procedure has failed because of a problem that is not related to specific printheads, for example, a problem with the media. <i>Press ↓ to continue. The message “Check ink system→ / Ignore→” should be displayed. If you press ↓ again to continue, you may still be able to print again, but image print quality may be affected. To fix the problem, select ↑ to check the ink system; see 11-35, Printhead Alignment Errors.</i>



Message	Explanation and Action
<p>Printhead check cancelled→</p>	<p>The printhead check procedure has failed, or the printer has detected a fault that stops the procedure from completing. Subsequent messages will explain the error further:</p> <ul style="list-style-type: none"> <li>■ “Replacement of lens cover recommended”—<i>You should check the section on replacing lens covers on page 10-3, Lens Maintenance.</i></li> <li>■ “Media too small for calibration”—The roll that is loaded is not wide enough for the check to be done. It must be at least A3 size. <i>You should load appropriate media and repeat the check again, using <b>Image Quality / Printhead Service / Printheads Check / Now</b>. If you use sheet media that is too small, the printer will reject the media and prompt you to load new media.</i></li> </ul> <p><i>Press ↓ to continue. You may continue printing, but you may not get your usual image print quality. To fix problems with the ink system, see 11-38, Checking Ink Systems.</i></p>
<p>Printhead check error ■■□■→ or Printhead check error →</p>	<p>The message “Printhead check error” may be displayed if:</p> <ul style="list-style-type: none"> <li>■ <i>You are using colored media. Either disable checking or use media that is clean, white, and opaque. See the remarks on 11-35, Media Problems.</i></li> <li>■ <i>There are dirty nozzles on the printhead. Replace your ink system (see page 11-38, Checking Ink Systems). Do not attempt to clean the nozzles.</i></li> </ul> <p>The squares that are flashing indicate the ink systems that have failed. If the message contains no squares, the procedure has failed because of a problem that is not related to specific printheads, for example, a problem with the media.</p> <p><i>Press ↓ to continue. The message “Check ink system→ / Ignore→” will be displayed. If you press ↓ again to continue, you may still be able to print again, but image print quality may be affected. To fix the problem, select ↑ to check the ink system; see 11-38, Checking Ink Systems.</i></p>
<p>Printhead contact error ■■□■→</p>	<p>The printheads, indicated by flashing squares, have failed to function because of an unusual electrical signal from the printhead. The most likely cause of this message is that the electrical contacts on the printhead or printer carriage are dirty and need cleaning.</p> <p><i>Press the ↓ key to check the printheads. Open the window when indicated, and remove the printheads indicated.</i></p> <p><i>Look at the electrical contacts on the printhead and carriage. If they are dirty, they should be cleaned (see 11-42, Cleaning Electrical Contacts).</i></p> <p><b>CAUTION:</b> <i><b>Do not touch, wipe, or attempt to clean the printhead nozzles. This can damage the printhead. Handle the ink systems with care.</b></i></p> <p><i>If you don’t correct the error now, you will see the status message “Ink system error” described on page 12-7.</i></p>

Message	Explanation and Action
Printhead failure ■ ■ □ ■ →	<p>The printheads indicated by flashing squares have failed, either during printhead initialization or during printing. The printer may have detected an unusual electrical or thermal signal from the printhead that may require attention. The most likely causes of this message are:</p> <ul style="list-style-type: none"><li>■ The ink cartridge is empty. If this is so, your ink system has reached the end of its normal life, and you will need to buy a new ink system to replace the old one.</li><li>■ There has been a problem inside the printhead that has caused it to fail, for example, the printhead has overheated.</li></ul> <p><i>You should replace the indicated ink systems immediately.</i></p> <p><i>Press the ↓ key to check the printheads. Open the window when indicated, and remove the printheads indicated. Try reseating the printhead (see If You Have Problems Reseating a Printhead 11-41). If the problem recurs, the ink system should be replaced at the earliest opportunity.</i></p> <p><i>If you don't correct the error now, you will see the status message "Ink system error" described on page 12-7.</i></p>
Printhead removed ■ ■ □ ■ →	<p>The printer has detected that one or more printheads have become dislodged or the printer cannot detect them, as indicated by the flashing squares.</p> <p><i>Press ↓ to continue. You should reseat the printheads immediately or replace the ink system; see 11-38, Checking the Printheads.</i></p> <p><i>If you don't correct the error now, you will see the status message "Ink system error" described on page 12-7.</i></p>
Printing disabled →	<p>The printer cannot print, because of errors previously notified.</p> <p><i>Press ↓ to continue. Then press the <b>Replace Ink System</b> key to replace the erroneous ink systems in order to print with your printer again. See 11-38, Checking Ink Systems.</i></p>
Pull ↓ Align ↔ edges to roll	<p>You are aligning roll media.</p> <p><i>Grasp the left and right free edges of the roll media and pull them towards you until the media is taut. At the same time, align the left and right edges of the media so that they are flush with the left and right edges of the roll.</i></p>
Reload media	<p>There was an error loading the media and the printer has ejected it. The printer is waiting for you to reload the media.</p> <p><i>Reload the media.</i></p>
Reload sheet	<p>Sheet media was loaded skewed and the printer ejected it.</p> <p><i>Reload the sheet.</i></p>

---

Message	Explanation and Action
Remove all ink cartridge(s)	You have selected the option <b>Utilities / Transport mode</b> of the front-panel menu, and opened the left door when instructed.  <i>The printer is instructing you to remove all the ink cartridges.</i>
Remove all printheads	You have selected the option <b>Utilities / Transport mode</b> of the front-panel menu, and lifted the window when instructed.  <i>The printer is instructing you to remove all the printheads.</i>
Remove head cleaners Close right door	You have selected the option <b>Utilities / Transport mode</b> of the front-panel menu, and opened the right door when instructed.  <i>The printer is instructing you to remove all the printhead cleaners, and then close the right door.</i>
Remove media	The ink is dry.  <i>Remove the accuracy calibration print that has just been produced. Press ↓ to continue with accuracy calibration.</i>
Remove media Lift lever	An attempt to load media was made while the media lever was lowered.  <i>Remove the media, lift the lever, and reload media with the lever up.</i>
Remove the Media Weight Continue→	You are removing media from the Take Up Reel. Before you are able to do this you have to remove the Media Weight (see Glossary) and chapter 3.  <i>When you have removed the Media Weight press Continue→.</i>
Replace ink cartridge(s) ■■■■□	You are in the ink system replacement process, and opened the left door when instructed.  <i>The printer is waiting for you to replace the ink cartridges indicated by flashing squares.</i>
Replace lens cover Continue→	You are in the ink system replacement process, and lifted the window when instructed.  <i>The printer is waiting for you to replace the lens cover on the printhead carriage with a new one. Spare lens covers are inside the right door. Press ↓ to continue when you have completed the lens replacement. See the instructions for lens cover replacement on page 10-3, Lens Maintenance.</i>
Replace printhead(s) ■■■□■	You are in the ink system replacement process, and lifted the window when instructed.  <i>The printer is waiting for you to replace the printheads indicated by flashing squares. (If you have persistent problems, see If You Have Problems Reseating a Printhead 11-41.)</i>

Front-Panel Messages  
Message Explanations and Actions

Message	Explanation and Action
Replace printhead(s) Close window	You are in the ink system replacement process, and lifted the window when instructed. <i>The printer is waiting for you to replace a printhead, or you can close the window without making any changes. (If you have persistent problems, see If You Have Problems Reseating a Printhead 11-41.)</i>
Replace ■■■■* Close right door	You are in the ink system replacement process, and opened the right door when instructed. <i>The printer is waiting for you to replace the printhead cleaners indicated by *s, and then close the right door.</i>
Replacement of ink system recommended→	You are about to finish the ink system replacement process, and the printer recommends replacing one or more of the four ink systems (for example, because they have passed their specified life). <i>Press the ↓ key to continue. You will see the status message “Low on ink”. Then press the <b>Replace Ink System</b> key to replace the ink systems that will be indicated.</i>
Replacement of lens cover recommended→	The printhead alignment procedure, or the printhead check procedure, or a calibration check has failed because the lens cover is dirty and needs replacing. Printing may continue but the image quality is not assured. <i>Press ↓ to continue. See the instructions for lens cover replacement on page 10-3, Lens Maintenance. Spare lens covers are inside the right door.</i>
Resource area full Unable to save res.	(HP DesignJet 2500CP only) The printer’s hard disk is full. You are attempting to save resources. The printer is unable to process the request. <i>You need to remove some of the resources from the hard disk, for example, saved print files, halftones, or fonts that you don’t use. Then try saving the resource again.</i>
Roll empty Load new roll	You have used all of the media roll. <i>Load a new roll of media.</i>
Roll misaligned Reload roll	Roll media is skewed. <i>Reload media.</i>
Set transport→ Yes Mode→ No	You have selected transport mode in the front-panel menu. The printer is waiting for you to accept or reject the transport mode. Accepting transport mode starts the process of removing all ink systems. <i>Press ↑ to accept or press ↓ to reject.</i>
Sheet load→ Roll load→	<i>Press ↑ to load sheet media. Press ↓ to load roll media.</i>

Message	Explanation and Action
Sheet misaligned Reload sheet	Sheet media is skewed. <i>Remove it and reload it so that the left and right edges being loaded into the printer are square. The leading edge must also be straight.</i>
Sheet required for calibration	You have started an accuracy calibration check but media is not present. <i>Load media.</i>
Sheet / Roll? Reload media	<b>Either:</b> Sheet mode was chosen while loading roll media. <i>Reload media.</i> <b>Or:</b> a sheet more than 51 inches (130 cm) long was loaded. <i>Trim the sheet and reload.</i>
STATUS messages	See pages 12-17 through 12-21.
Switch power off	You have selected the transport mode shut-down sequence. The printer is waiting for you to turn the power switch, on the rear of the printer, to off. <i>Switch off the printer.</i>
Switch power off Check paper path	The printer may be jammed with media. <i>Turn off the printer. Check the media path and clear it if necessary. Then turn on the printer.</i>
Switch power off Check printhead path	The printhead carriage cannot move. The printer may be jammed with media. <i>Turn off the printer. Check the media path and clear it if necessary. Then turn on the printer.</i>
System Error 060000	The ambient light level in the area of your printer is too bright and is causing the optical sensor in your printer to malfunction. <i>Reduce the ambient light level or move the printer to a location where the light level is lower.</i>
System error XXXXXX	An internal error has occurred and a system error number is displayed. <i>Press <b>Enter</b>; this may clear the error and allow you to continue. If you cannot continue, turn off the printer, and then turn it on again. If you still see the system error message, record the system error number and call HP to have the printer serviced.</i>

Front-Panel Messages  
Message Explanations and Actions

Message	Explanation and Action
System error XXXXXX	An internal error has occurred and a system error number is displayed.  <i>Press <b>Enter</b>; this may clear the error and allow you to continue. If you cannot continue, turn off the printer, and then turn it on again. If you still see the system error message, record the system error number and call HP to have the printer serviced.</i>
System error XXXXXX XXXXXXXX	An internal error has occurred and a system error number is displayed.  <i>Press <b>Enter</b>; this may clear the error and allow you to continue. If you cannot continue, turn off the printer, and then turn it on again. If you still see the system error message, record the system error number and call HP to have the printer serviced.</i>
trim edge→ continue→	The Take Up Reel is turned on and you are about to load the media onto it, you now have the option of trimming the edge or to continue. <i>You only need to trim the edge if the media was damaged in the loading process or is not straight, It is important when loading media onto the Take Up Reel that the media is taped onto the core tube straight.</i>
UV inks YES→ installed NO→	After you have finished installing a new ink cartridge, you are asked to confirm that you have changed the type of ink cartridges from Imaging to UV Pigmented.  <i>Press ↑ to confirm that you have changed the ink cartridges from Imaging to UV Pigmented.</i>  <i>Press ↓ to indicate that you have not changed the ink cartridges from Imaging to UV Pigmented. You will then be given the opportunity of replacing the incorrect ink cartridges by the correct ones.</i>
Verify ink system ■■■□■→	At power-on, the printer has detected an error in the ink systems shown by flashing squares.  <i>Press ↓ to continue. You should check the ink systems immediately; see 11-38, Checking Ink Systems.</i>
Wind the Take Up Reel Cut→	You are removing media from the Take Up Reel. Before you Cut the media to remove it, you must wind up the media onto the Take Up Reel or the media will fall to the floor and possible damage it. Press the wind button on the Take Up Reel and then press the ↓ key to cut the media.
System error XXXXXX XXXXXXXX	An internal error has occurred and a system error number is displayed.  <i>Press <b>Enter</b>; this may clear the error and allow you to continue. If you cannot continue, turn off the printer, and then turn it on again. If you still see the system error message, record the system error number and call HP to have the printer serviced.</i>

Message	Explanation and Action
trim edge→ continue→	The Take Up Reel is turned on and you are about to load the media onto it, you now have the option of trimming the edge or to continue. <i>You only need to trim the edge if the media was damaged in the loading process or is not straight, It is important when loading media onto the Take Up Reel that the media is taped onto the core tube straight.</i>
UV inks YES→ installed NO→	After you have finished installing a new ink cartridge, you are asked to confirm that you have changed the type of ink cartridges from Imaging to UV Pigmented.  <i>Press ↑ to confirm that you have changed the ink cartridges from Imaging to UV Pigmented.</i>  <i>Press ↓ to indicate that you have not changed the ink cartridges from Imaging to UV Pigmented. You will then be given the opportunity of replacing the incorrect ink cartridges by the correct ones.</i>
Verify ink system ■■■□■→	At power-on, the printer has detected an error in the ink systems shown by flashing squares.  <i>Press ↓ to continue. You should check the ink systems immediately; see 11-38, Checking Ink Systems.</i>
Wind the Take Up Reel Cut→	You are removing media from the Take Up Reel. Before you Cut the media to remove it, you must wind up the media onto the Take Up Reel or the media will fall to the floor and possible damage it.  Press the wind button on the Take Up Reel and then press the ↓ key to cut the media.

## STATUS Messages

Message	Explanation and Action
STATUS Accessing head cleaners	You have pressed the <b>Replace Ink System</b> key or there is an error in the head cleaners and you have pressed ↑ or ↓. The carriage is moving so that you can access the printhead cleaners.  <i>Wait until the carriage is in position.</i>
STATUS Accessing printheads	You have pressed the <b>Replace Ink System</b> key or there is an error in the printheads and you have pressed ↑ or ↓. The carriage is moving out so that you can access the printheads.  <i>Wait until the carriage is in position.</i>

Front-Panel Messages  
Message Explanations and Actions

Message	Explanation and Action
STATUS Aligning printheads	The printer is printing a pattern to align the printheads. <i>Wait until the pattern has been printed.</i>
STATUS Calibrating	The printer is performing the accuracy calibration check. <i>Wait until the printer has finished the check.</i>
STATUS Calibrating color	(HP DesignJet 2500CP only) The printer is performing a color calibration. <i>Wait until the printer has finished calibrating.</i>
STATUS Calibrating printhds	The printer is performing an internal printhead calibration. <i>Wait until the printer has finished calibrating.</i>
STATUS Cancelling	The <b>Cancel</b> key has been pressed and the printer is in the process of cancelling a file or procedure. <i>Continue when this message is no longer displayed.</i>
STATUS Check pending	The right door has been opened while the printer was busy (for example, printing) and the printer is waiting to check the ink system. You may have done something that will affect image print quality. <i>Do not open any door or window on the printer when not instructed and it is busy.</i>
STATUS Checking ink system	The printer is verifying that the ink system was correctly installed, or that all the components are present after any door or window on the printer has been opened. <i>Wait until the check is complete.</i>
STATUS Checking media	The printer is checking to see if media is correctly positioned with respect to the perforated line of the entry platen. <i>Wait until the check is complete.</i>
STATUS Checking printheads	The printer is printing a pattern to test the printheads. <i>Wait until the check is complete.</i>
STATUS Creating pattern	The printer is performing an accuracy calibration. <i>Wait until the calibration is complete.</i>
STATUS Head cleaner(s) full	One or more of the printhead cleaners are full of ink. The printer will continue printing but image print quality may be affected, and ink may leak inside the printer and damage it. <i>Press the <b>Replace Ink System</b> key to replace the ink systems affected. See 11-38, Checking Ink Systems.</i>



Message	Explanation and Action
STATUS Initializing	The printer is doing an internal check on power-up. <i>Wait until the printer has finished initializing.</i>
STATUS Ink drying (xx m xxs)	The ink on your print is drying. <i>Wait before removing the print. If you remove it before the indicated time has passed, avoid smearing the ink.</i>
STATUS Lens maintenance	The lens cover on the printhead carriage requires maintenance. <i>Press the <b>Replace Ink System</b> key to replace the lens cover with a new one. Spare lens covers are inside the right door. See the instructions for lens cover replacement on page 10-3, Lens Maintenance.</i>
STATUS Loading roll	The printer is loading roll media. <i>Wait for the loading to complete.</i>
STATUS Loading sheet	The printer is loading sheet media. <i>Wait for the loading to complete.</i>
STATUS Low on ink	One or more of the four ink systems are out of ink. <i>Press the <b>Replace Ink System</b> key to replace the ink systems affected, if the last print showed any degradation in image print quality. If there is still a large amount of ink remaining in the ink cartridges, see the message Printhead failure on page 12-12.</i>
STATUS Maintenance advised	The printer is being used more intensively than the recommended duty cycle. <i>You should contact your local HP dealer or HP service engineer to arrange a service. If you choose to ignore the message, you may continue to use the printer as normal, but may encounter a number of operational or print-quality problems.</i>
STATUS Measuring pattern	The printer is measuring the accuracy calibration print that you just loaded. <i>Wait for the calibration to complete.</i>
STATUS Out of media	The printer has received a file, is ready to print, but has no media loaded. <i>Load appropriate media.</i>
STATUS Pause pending	You have pressed the <b>Pause</b> key but the printer was busy performing a previous action. The printer will pause when it has completed its current action. <i>Wait for the current action to complete.</i>

Front-Panel Messages  
 Message Explanations and Actions

Message	Explanation and Action
STATUS Paused	You have pressed the <b>Pause</b> key. The printer will remain paused until you press the <b>Pause</b> key again.  <i>Press the <b>Pause</b> key again when you are ready.</i>
STATUS Printing	The printer is printing.  <i>Wait for the printing to complete.</i>
STATUS Printing (Special)	The printer is printing with a special print mode controlled by your software rather than by the printer.  <i>Wait for the printing to complete.</i>
STATUS Processing	The printer has received a file from your software and is processing it ready to print.  <i>Wait for the printing to complete.</i>
STATUS Ready	The printer is ready to print.  <i>Send a file to the printer.</i>
STATUS Ready for media	The printer is ready for you to load media.  <i>Load appropriate media.</i>
STATUS Receiving	The printer has received data.  <i>Wait for further messages.</i>
STATUS Recovering printhds.	The printer is recovering the printheads after an ink system replacement process (only for UV Pigmented inks), or you have initiated the printhead recovery procedure under <b>Utilities / Service Tests/ Recover Printheads</b> .  <i>Wait for the printhead recovery procedure to complete.</i>
STATUS Refilling XmXX s	The printer is filling the printheads. <i>(This message only applies to firmware revision levels A.02.08 or higher.)</i>  <i>Wait for the process to complete.</i>
STATUS Returning printheads	The ink system replacement process has been cancelled, and the printhead carriage is returning to its station at the right of the printer.  <i>Wait until the carriage is in position.</i>
STATUS Roll feed edge trim	The printer is trimming the edge of roll media.  <i>Wait until the media has been trimmed.</i>

<b>Message</b>	<b>Explanation and Action</b>
STATUS Waiting nest	Nesting is turned on. The printer is waiting for another print to nest. <i>Send the printer another file for printing.</i>

Front-Panel Messages  
Message Explanations and Actions

---

# Reference

# 13

---

Printer Specifications 13-2

Interface Specifications 13-10

Interface Cables 13-11

Regulatory Notices 13-12

Declaration of Conformity 13-16

Ordering Accessories 13-18

# Printer Specifications

## Functional Specifications

<b>Ink systems</b>	HP DesignJet CP Ink System: (Supplied with printer)		HP DesignJet CP Ink System UV: (Can be ordered separately)	
	Four: yellow, cyan, magenta and black. 600 dpi, 240 nozzle, 7.5kHz. Each color cartridge contains 410 ml of usable ink.		Four: yellow, cyan, magenta and black. 600 dpi, 240 nozzle, 4kHz. Each color cartridge contains 410 ml of usable ink.	
<b>Media sizes</b>	Width (carriage axis)		Length (media axis)	
	Minimum	Maximum	Minimum	Maximum length of long axis plot.
<b>Roll</b>	210 mm (8.3 in)	917 mm (36.1 in)	210 mm (8.3 in)	Depending on the media. Some examples are shown below.  Coated paper: 45.7m (150.0ft) HP Heavy weight Coated paper: 30.48m (100ft).
<b>Sheet</b>	210 mm (8.3 in) A/A4	831 mm (32.7 in) E/A0	263 mm (10.3 in) A/A4	1.6 m (62.99 in)
<b>Media types</b>	<b>For use with: HP DesignJet CP Ink System:</b>		<b>For use with: HP DesignJet CP Ink System UV:</b>	
See also Supplies Source catalog and (in Europe and USA) HP Media Guide for the HP DesignJet CP Printers. For alternative names, HP commercial names and physical characteristics of these media types, see chapter 3.	HP Coated Paper HP Heavyweight Coated Paper HP High-Gloss Photo Paper HP Semi-Gloss Photo Paper Imaging Film (back-lit) Opaque Vinyl		HP Heavy coated paper 3M Opaque Imaging Media 3M Lustre Overlamine 3M Matte Overlamine 3M High-Gloss Overlamine	
	<b>NOTE:</b> To print in monochrome on all media all four ink systems must be installed.  From time to time, new media types may become available. For up-to-date information, please contact your HP dealer or local HP Sales and Support Office.			

## Functional Specifications

<b>Margins</b>		Normal	Smaller (roll media only)	Extended (roll media only)(default)
<b>Using CP ink systems (Imaging)</b>	Leading edge:	19 mm (0.75 in)	10 mm (0.39 in)	29 mm (1.14 in)
	Trailing edge:	17 mm (0.67 in)	10 mm (0.39 in)	27 mm (1.06 in)
	Sides:	15 mm (0.59 in)	15 mm (0.59 in)	15 mm (0.59 in)
<b>Using CP ink systems (UV) with HP or 3M media</b>	Leading edge:	46 mm (1.81 in)	10 mm (0.39 in)	56 mm (2.20 in)
	Trailing edge:	17 mm (0.67 in)	10 mm (0.39 in)	27 mm (1.06 in)
	Sides:	15 mm (0.59 in)	15 mm (0.59 in)	15 mm (0.59 in)
		All measurements $\pm 2$ mm (0.08 in).		
<b>Resolution by Print Mode setting</b>	Fast	300 x 300 dpi.		
	Normal	300 x 300 dpi.		
	Best	600 x 600 dpi.		

<b>Programming languages supported</b>	HP-RTL (with color extensions) HP-GL/2 Adobe PostScript Level 3 (supports Asian languages) PJM, PML			
<b>Accuracy selection</b>	<b>Optimized</b>	<b>Constant</b>	<b>Maximum</b>	
Using HP Matte film as the reference test media at 23°C (73°F), 50-60% relative humidity.	$\pm 1.2\%$ of the specified page length	$\pm 0.7\%$ of the specified page length	$\pm 0.2\%$ of the specified page length	
<b>Programming languages supported</b>	HP-RTL (with color extensions) HP-GL/2 PJM, PML			

## Physical Specifications

	Weight	Length	Depth	Height
<b>Packed Unit</b>	115 kg (253 lbs)	1770 mm (69.7 in)	600 mm (23.6)	980 mm (38.6in)
<b>Printer assembled and ready to print</b>	83 kg (183 lbs) 100kg (220lbs) (with Take Up Reel)	1560 mm (61.4 in)	735 mm (28.9)	1225 mm (48.3in)

Reference  
Printer Specifications

### Memory Specifications

<b>Memory (2500CP only)</b>	36 MB RAM (standard)	4.3 Gb Hard Disk	Can be expanded up to 68 (+4) MB RAM
<b>Memory (2000CP only)</b>	8 MB RAM (standard)		Can be expanded up to 68 (+4) MB RAM

### Printing Specifications

#### **3M<sup>TM</sup> MCS<sup>TM</sup> Warranty for Graphics Produced on HP DesignJet CP Printers**

Graphics made with 3M<sup>TM</sup> Changeable Opaque Imaging Media 8522CP, HP DesignJet CP Ink System UV and 3M<sup>TM</sup> Luster Overlamine 8519CP or 3M<sup>TM</sup> Matte Overlamine 8520CP, by 3M<sup>TM</sup> TIJ Graphics Certified Fabricators on HP DesignJet CP printers and according to manufacturers recommendations, *are warranted for 24 months outdoors\** and 5 years indoors.

\* For desert areas of the world with extreme solar energy the warranty period is 18 months outdoors and 5 years indoors. Refer to section 5 of the Reference Manual contained in the 3M<sup>TM</sup> Thermal InkJet Graphics Certified Fabricator Starter Kit 8590CP for specific details.

### Duty Cycle

<b>Average number of prints per day</b>	15 prints per day of 8ft <sup>2</sup> (0.74 m <sup>2</sup> ) over 5 years.
---	--



### Printer Power Specifications

<b>Source</b>	100-240V ac $\pm 10\%$ . Autoranging.
<b>Frequency</b>	50-60 Hz
<b>Current</b>	2 Amp maximum
<b>Consumption</b>	120 Watts maximum
<b>Energy Star rating (USA)</b>	Maximum power in idle state: 45 watts.

### Take Up Reel Power Specifications

<b>Source</b>	100-240V ac $\pm 10\%$ . Autoranging.
<b>Frequency</b>	50-60 Hz
<b>Current</b>	0.2 amp maximum
<b>Consumption</b>	15 watts maximum

### Ecological Specifications

<b>Energy efficiency</b>	Standby mode: 30 watts. Compliant with Energy Star Program EPA (US).
<b>Manufacturing process</b>	Free of ozone-depleting chemicals (Montreal Protocol).
<b>Plastics</b>	Free of brominated flame retardants (PBB and PBDE). All housing parts made of the same material: ABS. 90% of parts marked according to ISO 11469 standard.
<b>Metals</b>	Chassis made of aluminum. Shafts made of stainless steel. Enclosures made of electro-galvanized steel sheet.
<b>Packaging</b>	Cardboard (non-chlorine-bleached) and foam are 100% recyclable. Inks used for printing do not contain heavy metals.
<b>User Documentation</b>	Majority can be recycled, not bleached with chlorine and printed with inks that do not contain heavy metals. For specification of this User Guide see the back cover.
<b>Batteries</b>	Not used.
<b>Recyclability</b>	Modular construction, connecting elements snap-type can be re-used, screws easy to find and disassembly done using universal tools.

**Environmental Specifications**

<b>Environmental Operating Range</b>	Optimal print quality:	15°C to 30°C (59° F to 86° F)
	Standard:	15°C to 35°C (59° F to 95° F)(except glossy media: 15°C to 30°C (59° F to 86° F)
	Operating Relative Humidity:	20% to 80% Noncondensing
<b>Storage ranges</b>	95% humidity	-40°C to 70°C (-40° F to 158° F)
	Printhead and Printhead Cleaners stored in the HP DesignJet CP Ink System Storage Container: Temperature: +15°C to +35°C (+59° F to +95° F) @ 20% - 80% Relative Humidity	

**Acoustic Specifications**

<b>Operating sound pressure</b>	42 dB(A)(From a one-meter bystander position)
<b>Idle sound pressure</b>	<26dB(A) (From a one-meter bystander position)
<b>Operating sound power</b>	5.6 Bels (A)
<b>Idle sound power</b>	<3.9 Bels (A)

### Printer EMC (ElectroMagnetic Compatibility) Specifications

<b>Canada</b>	Canadian Department of Communications, Radio Interference Regulations Class B <sup>1</sup> compliant.
<b>European Union</b>	89/336/EEC EMC Directive compliant. Meets EN 55022 Class B <sup>1</sup> emission limits, prEN 55024-2 ESD, prEN55024-3 Radiated Immunity, prEN 55024-4 Fast Transients.
<b>Japan</b>	Registered VCCI Class B <sup>1</sup> .
<b>Korea</b>	RRL certified.
<b>South Africa</b>	SABS licensed.
<b>USA</b>	Federal Communications Commission. Class B <sup>1</sup> computing device. CFR 47 Part 15
<b>Australia New Zealand</b>	Meets AS/NZS 3548
<b>Taiwan (ROC)</b>	BCIQ Certified

<sup>1</sup> Product exhibits Class A operation when connected to LAN cables using Print Server accessories

### Take Up Reel EMC (ElectroMagnetic Compatibility) Specifications

<b>Canada</b>	Canadian Department of Communications, Radio Interference Regulations Class B compliant.
<b>European Union</b>	89/336/EEC EMC Directive compliant. Meets EN 55022 Class B emission limits, prEN 55024-2 ESD, prEN55024-3 Radiated Immunity, prEN 55024-4 Fast Transients.
<b>South Africa</b>	SABS licensed.
<b>USA</b>	Federal Communications Commission. Class B digital device. CFR 47 Part 15
<b>Australia New Zealand</b>	Meets AS/NZS 3548
<b>Taiwan (ROC)</b>	BCIQ Certified

**Printer Safety Specifications**

Information Technology Equipment (ITE), Movable, Class I, Plugable Type A, Installation Category II, Pollution Degree 2. For indoor controlled office environments use.	
<b>Canada</b>	Canadian Standards Association “Certified” ITE, CSA C22.2 No.950
<b>European Union</b>	73/23/EEC Low Voltage Directive compliant. Meets EN 60950
<b>Mexico</b>	DGN, NOM019-SCFI-1994 certified
<b>Norway</b>	NEMKO approved, EN 60950, EMKO TSE(74)DK207/94
<b>USA</b>	Underwriters' Laboratories “Listed” ITE, UL 1950
<b>China</b>	CCIB certified GB 4943-90 1st Ed.
<b>Czech Republic</b>	EZU, IEC950 certified.
<b>Singapore</b>	PSB, SS337 certified
<b>Poland</b>	PCBC Certified
<b>Russia</b>	GOST Certified

**Take Up Reel Safety Specifications**

Constructed according to Information Technology Equipment (ITE) Safety Standard IEC950 Fixed, Class I, Plugable Type A, Installation Category II, Pollution Degree 2. For indoor controlled office environments use.	
<b>Canada</b>	Canadian Standards Association “Certified” ITE, CSA C22.2 No.950
<b>European Union</b>	73/23/EEC Low Voltage Directive compliant. Meets EN 60950
<b>Mexico</b>	DGN, NOM019-SCFI-1994 certified
<b>Norway</b>	EN 60950, EMKO TSE(74)DK207/94 compliant.
<b>USA</b>	Underwriters' Laboratories UL 1950 Listed
<b>Czech Republic</b>	EZU, IEC950 certified.
<b>Poland</b>	PCBC certified
<b>Russia</b>	GOST certified

**Printing Area (= Media Size Minus Margins)**

	Media Size (and Orientation of Media)		Printing Area (Width x Height) by Orientation of Drawing			
			inches		millimeters	
			landscape	portrait	landscape	portrait
<b>ANSI media</b>	A	(portrait)	9.5 x 7.2	7.2 x 9.5	243 x 185	185 x 243
	A	(landscape)	9.8 x 7.0	7.0 x 9.8	249 x 180	180 x 249
	B	(portrait)	15.5 x 9.8	9.8 x 15.5	395 x 249	249 x 395
	B	(landscape)	15.7 x 9.5	9.5 x 15.7	401 x 243	243 x 401
	C	(portrait)	20.5 x 15.7	15.7 x 20.5	522 x 401	401 x 522
	C	(landscape)	20.8 x 15.5	15.5 x 20.8	529 x 396	396 x 529
	D	(portrait)	32.5 x 20.7	20.7 x 32.5	827 x 528	528 x 827
	D	(landscape)	32.8 x 20.5	20.5 x 32.8	834 x 523	523 x 834
	E	(portrait)	42.6 x 32.8	32.8 x 42.6	1082 x 834	834 x 1082
<b>Architectural media</b>	A	(portrait)	10.5 x 7.8	7.8 x 10.5	268 x 119	199 x 268
	A	(landscape)	10.8 x 7.6	7.6 x 10.8	275 x 193	193 x 275
	B	(portrait)	16.5 x 10.8	10.8 x 16.5	421 x 275	275 x 421
	B	(landscape)	16.8 x 10.5	10.5 x 16.8	427 x 269	269 x 427
	C	(portrait)	22.6 x 16.8	16.8 x 22.6	574 x 427	427 x 574
	C	(landscape)	22.8 x 16.5	16.5 x 22.8	580 x 421	421 x 580
	D	(portrait)	34.5 x 22.8	22.8 x 34.5	878 x 580	580 x 878
	D	(landscape)	34.8 x 22.6	22.6 x 34.8	884 x 574	574 x 884
	E1	(portrait)	40.5 x 28.8	28.8 x 40.5	1031 x 732	732 x 1031
E	(portrait)	46.5 x 34.8	34.8 x 46.5	1183 x 884	884 x 1183	
<b>ISO media</b>	A4	(portrait)	10.2 x 7.0	7.0 x 10.2	261 x 180	180 x 261
	A4	(landscape)	10.1 x 6.8	6.8 x 10.1	257 x 174	174 x 257
	A3	(portrait)	15.1 x 10.5	10.5 x 15.1	384 x 267	267 x 384
	A3	(landscape)	14.9 x 10.2	10.2 x 14.9	380 x 261	261 x 380
	A2	(portrait)	21.9 x 14.9	14.9 x 21.9	558 x 380	380 x 558
	A2	(landscape)	22.2 x 15.1	15.1 x 22.2	564 x 384	384 x 564
	A1	(portrait)	31.6 x 21.8	21.8 x 31.6	805 x 554	554 x 805
	A1	(landscape)	31.5 x 20.6	20.6 x 31.5	801 x 524	524 x 801
	A0	(portrait)	45.3 x 31.5	31.5 x 45.3	1153 x 801	801 x 1153

**For margins, see page 5-12. This table is calculated using normal margins with imaging ink**

## Interface Specifications

Below are the parallel interface specifications.

For specifications of the HP JetDirect Print Server (Network Interface), see the JetDirect Print Server documentation supplied with this printer. For specifications of the Optional HP JetDirect Print Server (Network Interface), see the JetDirect Print Server documentation supplied with the Print Server Interface or consult your dealer.

### Parallel (IEEE-1284 compatible/Centronics) Interface

<b>The connector on the printer is 36-pin female.</b> <b>Most existing parallel cables support Bi-Tronics communication, but for use with this printer, the cable must meet the specification in this table.</b>	Pin	Wire/Signal Name	Source
	1	Strobe	computer
	2 ... 9	D0 ... D7 (data lines)	both
	10	Ack	printer
	11	Busy	printer
	12	PError	printer
	13	Select (SelectOut)	printer
	14	AutoFd	computer
	16	GND	
	19 ... 30	GND	
	31	Init	computer
	32	Fault	printer
	36	SelectIn	computer

---

## Interface Cables

The following cables are recommended for optimum performance and electromagnetic compatibility:

<b>Cables for Macintosh Computers</b>			
<b>Interface type (Computer)</b>	<b>HP part number</b>	<b>Cable length</b>	<b>Connector type at computer end of cable</b>
Serial (RS 422) Interface (Apple Macintosh Plus, SE, II Series, Classic, LC family, Quadra family, PowerBook, PowerMac)	92215S	1.5 m (4.9 ft.)	8-pin male mini- DIN

<b>Cables for PCs</b>			
<b>Interface type (Computer)</b>	<b>HP part number</b>	<b>Cable length</b>	<b>Connector type at computer end of cable</b>
IEEE compatible/Centronics Interface (All)	C2951A	3.0 m (9.8 ft.)	25-pin male

<b>Cables for Unix Systems</b>			
<b>Interface type (Computer)</b>	<b>HP part number</b>	<b>Cable length</b>	<b>Connector type at computer end of cable</b>
Parallel (IEEE compatible/Centronics) Interface (All)	C2951A	3.0 m (9.8 ft.)	25-pin male

## Regulatory Notices

### To Obtain a Material Safety Data Sheet (MSDS)

You can obtain current Material Safety Data Sheets for the ink systems used in the printer (HP part numbers for Imaging inks: C1806A [black], C1807A [cyan], C1808A [magenta] and C1809A [yellow]) (HP part numbers for UV Pigmented inks: C1892A [black], C1893A [cyan], C1894A [magenta] and C1895A [yellow]) by mailing a request to this address: **Hewlett-Packard Customer Information Center**, 19310 Pruneridge Avenue, Dept. MSDS, Cupertino, CA 95014, U.S.A.

### Sound

#### Geräuschemission (Germany)

LpA < 70 dB, am Arbeitsplatz, im Normalbetrieb, nach DIN 45635 T. 19.

### Electro-Magnetic Compatibility (EMC)

#### FCC Statements (U.S.A.)

The U.S. Federal Communications Commission (in 47 cfr 15.105) has specified that the following notices be brought to the attention of users of this product.

#### Product identification numbers:

HP DesignJet 2000CP	C4703A
HP DesignJet 2500CP	C4704A
Take Up Reel	C6246A

This device complies with part 15 of the FCC rules. Operation is subject to the following two conditions: (1) This device may not cause harmful interference, and (2) this device must accept any interference received, including interference that may cause undesired operation.

#### Shielded cables

Use of a shielded parallel data cable is required to comply with the Class B limits of Part 15 of the FCC Rules.



---

**CAUTION**

---

**Pursuant to Part 15.21 of the FCC Rules, any changes or modifications to this equipment not expressly approved by the Hewlett-Packard Company, may cause harmful interference and void the FCC authorization to operate this equipment.**

**NOTE:**This equipment has been tested and found to comply with the limits for a Class B digital device, pursuant to part 15 of the FCC Rules. These limits are designed to provide reasonable protection against harmful interference in a residential installation. This equipment generates, uses and can radiate radio frequency energy and, if not installed and used in accordance with the instructions, may cause harmful interference to radio communications. However, there is no guarantee that interference will not occur in a particular installation. If this equipment does cause harmful interference to radio or television reception, which can be determined by turning the equipment off and on, the user is encouraged to try and correct the interferences by one or more of the following measures:

- Reorient the receiving antenna
- Increase the separation between the equipment and the receiver
- Connect the equipment into an outlet on a circuit different from that to which the receiver is connected
- Consult the dealer or an experienced radio/TV technician for help

The user may find useful the following booklet prepared by the FCC: “*How to Identify and Resolve Radio-TV Interference Problems*”. This booklet is available from the US Government Printing Office, Washington, DC 20402, Stock No. 004-000-00345-4.

**When connected to LAN cables using print server accessories...**

This equipment has been tested and found to comply with the limits for a Class A digital device, pursuant to part 15 of the FCC Rules. These limits are designed to provide reasonable protection against harmful interference in a commercial environment. This equipment generates, uses and can radiate radio frequency energy and, if not installed and used in accordance with the instructions, may cause harmful interference to radio communications. Operation of this equipment in a residential area is likely to cause harmful interference in which case the user will be required to correct the interference at their own expense.

**Normes de sécurité  
(Canada)**

Le présent appareil numérique n'émet pas de bruits radioélectriques dépassant les limites applicables aux appareils numériques de *Classe B* prescrites dans le règlement sur le brouillage radioélectrique édicté par le Ministère des Communications du Canada.

*Connecté à un réseau par des accessoires de serveur, l'appareil n'émet pas de bruits radioélectriques dépassant les limites applicables aux appareils numériques de Classe A prescrites dans le règlement sur le brouillage radioélectrique édicté par le Ministère des Communications du Canada.*

**DOC statement  
(Canada)**

This digital apparatus does not exceed the *Class B* limits for radio noise emissions from digital apparatus set out in the Radio Interference Regulations of the Canadian Department of Communications.

*When connected to LAN cables using print server accessories, this digital apparatus does not exceed the Class A limits for radio noise emissions from digital apparatus set out in the Radio Interference Regulations of the Canadian Department of Communications.*

**VCCI Class A and  
class B (Japan)**

この装置は、情報処理装置等電波障害自主規制協議会（V C C I）の基準に基づく第二種情報技術装置です。この装置は、家庭環境で使用することを目的としていますが、この装置がラジオやテレビジョン受信機に近接して使用されると、受信障害を引き起こすことがあります。

取り扱い説明書に従って正しい取り扱いをして下さい。

**注意**

IEEE802.3 もしくは Ethernet に接続されている場合、この装置は、情報処理装置等電波障害自主規制協議会（V C C I）の基準に基づく第一種情報技術装置です。この装置を家庭環境で使用すると電波妨害を引き起こすことがあります。この場合には使用者が適切な対策を講ずるよう要求されることがあります。

**Korean EMI  
statement**

이 기기는 업무용으로 전자파장애검정을 받은 기기이오니 판매자 또는  
사용자는 이점을 주의하시기 바라며 만약 잘못 구입하였을 때에는 구입한  
곳에서 비업무용으로 교환하시기 바랍니다

**Taiwanese EMI  
statement**

**警告使用者：**

這是甲類的資訊產品，在居住的環境中使用時，  
可能會造成射頻干擾，在這種情況下，使用者會  
被要求採取某些適當的對策。

**Tele-  
communications  
General Approval  
(UK)**

**Telecommunications Statement**

The HP DesignJet 2500CP and 2000CP printers, models C4703A and C4704A, are approved under Approval Number NS/G/1234/5/100003 for indirect connection to public telecommunication systems within the United Kingdom.

**Address**

Hewlett-Packard Company  
Manager of Corporate Product regulations  
3000 Hanover Street  
Palo Alto, CA 94304  
415/857-1501

# Declaration of Conformity

**DECLARATION OF CONFORMITY**  
according to ISO/IEC Guide 22 and EN 45014

**Manufacturer's Name:** Hewlett-Packard Española S.A.

**Manufacturer's Address:** Barcelona Division  
Avenida Graells, 501  
08190 Sant Cugat del Valles  
Barcelona, Spain

**declares that the product**

**Product Name:** HP DesignJet 2500CP and 2000CP Inkjet Printers

**Model Number (s):** HP C4703A, HP C4704A

**Product Accessory:** HP Jet Direct print servers (1), HP Take Up Reel

**conforms to the following Product Specification:**

**Safety:** IEC 950 (1991)+A1,A2, A3, A4/ EN 60950 (1992)+A1,A2,A3,A4  
CSA C22.2 No 950 (1995)  
UL 1950 (1995)  
NOM-019-SCFI-1994  
EMKO-TSE (74) DK 207/94  
GB 4943 (1990)  
IEC 825-1 (1993)/EN 60825-1 (1994) Class 1

**EMC:** EN 50081-1 (1992)  
CISPR 22:1993 / EN 55022 (1994): Class B (2)  
EN 50082-1 (1992)  
IEC 801-2:1991/prEN 55024-2 (1992): 4KV CD, 8KV AD  
IEC 801-3:1984/prEN 55024-3 (1991): 3V/m  
IEC 801-4:1988/prEN 55024-4 (1993): 1KV Power Lines,  
0.5KV Signal Lines  
IEC 1000-3-3:1994/EN 61000-3-3 (1995)  
FCC Part 15 - Class B/DOC-B/VCC1-2/RRL-A  
AS/NZS 3548/BCIQ-A

**Supplementary Information:**

The product herewith complies with the requirements of the Low-Voltage Directive 73/23/EEC and the EMC Directive 89/336/EEC and carries the CE marking accordingly.

- (1) Product exhibits class A operation when connected to LAN cables using print server accessories.
- (2) The product was tested in a typical system with a Hewlett Packard Personal Computer and second peripheral. An Apple Macintosh was used for Local Talk.

Sant Cugat del Valles (Barcelona),  
July 31st 1998

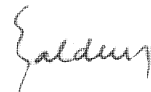

Jordi Balderas,  
Quality Engineering Manager

# Declaration of Conformity

**DECLARATION OF CONFORMITY**  
according to ISO/IEC Guide 22 and EN 45014

**Manufacturer's Name:** Hewlett-Packard Española S.A.  
**Manufacturer's Address:** Barcelona Division  
Avenida Graells, 501  
08190 Sant Cugat del Valles  
Barcelona, Spain

**declares that the product**

**Product Name:** HP Take Up Reel  
**Model Number (s):** HP C4723-60020, HP C6246A  
**Product Accessory:**

**conforms to the following Product Specification:**

**Safety:** IEC 950 (1991) + A1,A2,A3 / EN 60950 (1992) + A1,A2,A3(1)  
CSA C22.2 No 950 (1995)  
UL 1950 (1995)  
NOM-019-SCFI-1994  
EMKO-TSE (74) DK 207/94  
GB 4943 (1990)

**EMC:** EN 50081-1 (1992)  
CISPR 22:1993 / EN 55022 (1994): Class B (1)  
EN 50082-1 (1992)  
IEC 801-2:1991/prEN 55024-2 (1992): 4KV CD, 8KV AD  
IEC 801-3:1984/prEN 55024-3 (1991): 3V/m  
IEC 801-4:1988/prEN 55024-4 (1993): 1KV Power Lines,  
0.5KV Signal Lines  
IEC 1000-3-3:1994/EN 61000-3-3 (1995)  
FCC Part 15-Class B/Doc-B  
AS/NZS 3548/BCIQ-A

**Supplementary Information:**

The product herewith complies with the requirements of the Low-Voltage Directive 73/23/EEC and the EMC Directive 89/336/EEC and carries the CE marking accordingly.

(1) This product was tested in a typical system with a Hewlett Packard DesignJet series printer

Sant Cugat del Valles (Barcelona),  
July 31st 1998

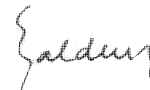

Jordi Balderas,  
Quality Engineering Manager

European Contact: Your local Hewlett-Packard Sales and Service Office or Hewlett-Packard GmbH, Department HQ - TRE,  
Herrenberger Strasse 130, D-71034 Boeblingen, Germany (FAX: +49 7031 143143)

## Ordering Accessories

Item		HP Part Number
Cables		See Page 13-11
Take Up Reel		C6246A
Documentation		
User's Guide and Quick Reference Guide	Chinese	C4704-60300
	English	C4704-60301
	French	C4704-60305
	German	C4704-60304
	Japanese	C4704-60308
	Italian	C4704-60307
	Korean	C4704-60302
	Portuguese	C4704-60309
	Spanish	C4704-60306
Software Application Notes (graphics packages)	Taiwanese	C4704-60303
	English	C4704-90051
	French	C4704-90055
	German	C4704-90054
Hewlett-Packard Support Services <sup>a</sup>	Italian	C4704-90057
	Spanish	C4704-90056
	Multilingual	C4699-90004 5965-2926 <sup>b</sup>
The HP-GL/2 and HP RTL Reference Guide	English	5961-3526 <sup>c</sup>
The Product Comparison Guide for HP-GL/2 and HP RTL Peripherals	English	5959-9734 <sup>c</sup>
PJL Technical Reference Manual	English	5021-0328

**a. This item is updated regularly. For details of the latest version available, please contact the web page <http://www.hp.com/go/designjet> .**

**b. This document is available in most European languages.**

**c. See page 13-20, *HP-GL/2 and HP RTL Programming Information*.**

To achieve the best performance from your printer, we recommend you only use genuine Hewlett-Packard accessories and supplies, whose reliability and performance have been thoroughly tested to give trouble-free performance. For Example:

- HP drivers are developed to support all the latest features and to optimize print quality and your printers performance.
- HP memory expansion modules are thoroughly tested to give you maximum performance.
- HP ink systems and media supplies are developed for optimal print quality.

Item	HP Part Number
Drivers <sup>a</sup>	
Latest versions of the following were shipped with this printer:	
HP DesignJet PostScript Driver for Power Macintosh and Macintosh <sup>a</sup>	
HP DesignJet PostScript Driver for Microsoft Windows <sup>a</sup>	
HP-GL/2 Windows Driver	
HP DesignJet HPGL/2/RTL autocad drivers.	
<b>Media Supplies</b>	
See the <i>Media Guide for the HP DesignJet CP Printers</i> <sup>a</sup> (The latest edition was shipped with this printer)	
<b>Memory Modules</b>	
All memory expansion modules are:	4 MB C6229A
4, 8, 16, or 32-MB SIMM 72 pin x 32 EDO 60	8 MB C6230A
nanoseconds.	16 MB C6231A
	32 MB C6232A
<b>Ink Systems</b>	HP DesignJet CP Ink System:
	Black C1806A
	Cyan C1807A
	Magenta C1808A
	Yellow C1809A
	HP DesignJet CP Ink System UV:
	Black C1892A
	Cyan C1893A
	Magenta C1894A
	Yellow C1895A
<b>HP DesignJet CP Ink System Storage Container</b>	C6236A
<b>Spindle Assembly</b>	C3173A

a. This item is updated regularly. For details of the latest version available, please contact the Hewlett Packard web page <http://www.hp.com> or your HP dealer or sales representative.

## **HP-GL/2 and HP RTL Programming Information**

*The HP-GL/2 and HP RTL Reference Guide* provides complete explanations and examples of the HP-GL/2 and HP RTL graphic and interfacing instructions. If you are writing an HP-GL/2 or RTL driver for your printer, you will find this guide an invaluable source of general instruction information. It is published by Addison-Wesley Publishing Company and you can order it through most book stores (ISBN 0-201-31014-7).

For specific parameter information, refer to *The Product Comparison Guide for HP languages on HP Plotters and large format printers*, which you can order through your HP Sales office part number 5959-9734.

## **How to Order Supplies and Accessories**

You can order supplies and accessories in any of the following ways:

- Call your local authorized HP dealer.
- Contact your local HP Sales and Support office.
- Refer to the *Hewlett-Packard Support/Services* booklet that was supplied with your printer.



## www.designjet-online.hp.com



*Direct access to HP and the information you want, when you need it. Register now!*

**HP DesignJet Online** is a free, web-based "user club" exclusive to HP DesignJet users. Having registered, the user has unrestricted access to a range of useful services, the emphasis being on "useful", as this is definitely *not* a sales-oriented site.

Communication from HP to users includes:

- a quarterly newsletter focussing on usage tips, technical briefings and examples of HP DesignJet applications around the world;
  - full information on worldwide HP Customer Care contacts;
  - an online *HP DesignJet Diagnosis* troubleshooting tool;
  - a calendar of HP DesignJet-related events and programs;
  - online access to training videos and selected user documents;
  - and immediate information on new products.
- Communication from the users to HP includes:
- feedback on HP DesignJet features;
  - automatic contact with HP Customer Care from the troubleshooting tool, for HP to follow up;
  - and the chance to ask technical questions on large-format printing to industry experts.

And finally, communication from user to user includes the chance to win prizes by submitting HP DesignJet success stories, as well as a user-to-user discussion forum where users can share best practices and ask for advice from their fellow professionals.

**HP DesignJet Online** is available in English, German, French, Italian, Spanish and Portuguese.

Reference  
[www.designjet-online.hp.com](http://www.designjet-online.hp.com)

---

# Glossary

**ac**

Alternating current.

**ANSI size**

An American standard media size; e.g. D, E

**application**

The software you use to create your drawings.  
font. The black metal bar inside the printer, which holds the media in place.

**Centronics**

A standard for the parallel interface between computer and device.

**clipping**

Losing part of a drawing at the edges.

**CMYK**

Cyan, magenta, yellow and black. The colors of the printer's four inks, and also a standard color model.

**core**

Part of the Take up reel. The media is wound around this while printing.

**coated paper**

Paper coated on one side for inkjet printing.

**default**

A value or condition that is assumed if no other value or condition is specified.

**device**

An external item connected to the computer: printer, plotter, tape drive, etc. Your HP DesignJet is a device.

**dpi**

Dots per inch, a measure of print resolution.

**driver**

The software that controls the communication between a computer and a device.

**front panel**

The control panel on the right of the printer.

**front-panel menus**

The structure of options in the front-panel display.

**graphics language**

A programming language telling a print device how to output graphic data.

**grayscale**

Shades of gray to represent colors.

**high-gloss photo**

A glossy, opaque photographic paper.

**HP-GL/2**

One of Hewlett-Packard's standard graphics languages for plotters and printers. Produces vector data. Newer than HP-GL.

**I/O Input/output**

The transmission of data between a computer and a device.

**inked area**

The smallest rectangle that contains all the content of the drawing, while maintaining its relative dimensions.

**ISO size**

An international standard media size; e.g. A1, A2, etc.

**JIS size**

A Japanese standard media size.

**LAN**

Local area network.

**long-axis printing**

Printing a page whose X-axis (the axis vertical to the printer as you look at it from the front) is longer than a standard page size.

**margin**

The space around the page added by the printer to separate one page from another and to avoid printing right to the edge of the media.

**matte**

Not glossy.

**media**

The material, usually paper, onto which the printer prints.

**media weight**

The media weight is designed to give the media path a loop shape just before it is wound onto the Take Up Core.

**MIO Modular input/output**

Refers to the printer's network interface.

**nesting**

Placing two or more pages side-by-side on roll media to avoid waste.

**palette**

A set of logical pens defined by color and width.

**PJL**

Printer Job Language. A programming language that controls jobs going to a printer.

**PML**

Printer Management Language.

**parallel interface**

A type of interface between computer and device. Generally faster than a serial interface.

**PANTONE**

The PANTONE MATCHING SYSTEM® is an international standard for color communication in the graphics art industry.

**pen**

Even though the plotter has no physical pens, the lines it draws match the attributes of a pen.

**platen**

The exterior part of the printer on which the media rests before going into the media-entry slot.

**printing area**

Page size minus margins.

---

**PostScript**

A standard page-markup language, commonly used by graphics and desktop publishing software applications.

**queueing**

Placing each print received by the device into memory for processing with other prints.

**raster**

A method for defining an image, in terms of dots rather than lines. Raster data typically needs more memory than vector data.

**RGB**

Red, green and blue. A standard color model.

**RIP**

Raster Image Processor.

**RTL (Raster Transfer Language)**

One of Hewlett-Packard's standard graphics languages for plotters and printers. Produces raster data.

**ROM SIMM**

A physical module containing read-only data, that

can be installed in the back of the printer to provide upgrades.

**semi-gloss photo**

A semi glossy, opaque photographic paper.

**spindle**

The rod which holds the roll of media.

**Take Up Core**

The Take Up Core is a plastic tube on the Take Up Spindle. The media is wound onto this as it is printed from the printer.

**Take Up Reel**

The assembly located underneath the printer which reels in the printed media as it is printed, thus enabling unattended printing.

**X-axis**

The vertical axis, as you look at the printer from the front.

**Y-axis**

The horizontal axis, as you look at the printer from the front.



# Index

## A

accessories and supplies  
     how to order 13-20  
 Accuracy 5-8  
 accuracy calibration 8-6  
 acoustic specifications 13-6  
 action keys 2-4  
 additional information,  
 configuration 11-26  
 adjusting page size 5-4  
     non-PostScript files 5-6  
     PostScript files 5-5  
 automatic cutting 5-14

## B

banding 11-11  
     color misalignment 11-15  
     media advance problems 11-13  
     printhead problems 11-11  
     solving problems 11-11  
     test pattern 11-10  
 black and white prints 11-49  
 blank print 11-46  
 blurred lines 11-26

## C

cables  
     interface 13-11  
 calibrating color output 9-3  
 calling HP 11-56  
 cancelling a page 7-2  
 changeable opaque vinyl, print  
 margins 5-14  
 changing ink systems 4-29

changing print mode 9-10  
 cleaning the printer 10-2  
 clear polyester film 3-8  
 clipped images 5-7  
     with rotation 5-18  
 clipped print 11-47  
 coated paper 3-8  
 color 11-6  
 color accuracy  
     troubleshooting 11-21  
 color alignment  
     troubleshooting 11-20  
 color and monochrome  
     switching between 6-11  
 color calibration  
     changing 2-17  
 color images  
     printing in monochrome 6-10  
 color inkjet paper 3-8  
 color misalignment  
     troubleshooting 11-15  
 color output  
     calibrating 9-3  
 color quality test 11-20  
 color variation  
     problems with 11-21  
 color variation test pattern 11-21  
 colors  
     internal palettes 6-3  
 compensating for badly cut media 3-43  
 computer communication 11-45

configuration problems 11-24  
 configuration settings 11-24  
 contents of image 11-46  
 controlling image quality 9-1, 12-1  
 CP ink system 4-2  
 current configuration  
     printing 2-7  
     viewing 8-5  
 cutter problems 11-29  
 cutting a page  
     before drying Is complete 7-3

## D

declaration of conformity 13-16  
 distorted prints 11-49  
 drying time  
     adjusting 3-46  
     changing 2-26  
 Drying time (with a Take Up Reel)  
 3-44  
 Drying time (without a Take Up  
 Reel) 3-46

## E

Ecological Specifications 13-5  
 electro-magnetic compatibility  
 (EMC) 13-12  
 EMC specifications 13-7  
 empty print 11-46  
 environmental specifications 13-6

## F

factory calibration  
     restoring 8-7  
 features, ink system 1-4

## Index

- fit to page 5-21
- fonts print 2-12
- front panel 2-2
  - action keys 2-4
  - display section 2-3
  - print mode keys 2-4
  - status lights 2-5
  - using 2-1
- front-panel display
  - types of information 2-28
- front-panel key problems 11-51
- front-panel message problems 11-51
- front-panel problems 11-51
- front-panel settings
  - changing 8-5
- G**
- getting support 11-56
- graphics language
  - changing 8-8
- graphics language and networks 8-9
- H**
- handling ink 4-24
- hardware interface test 11-4
- heavy coated paper 3-8
- heavyweight coated paper 3-8
- heavyweight color inkjet paper 3-8
- heavyweight inkjet paper 3-8
- heavyweight matte paper 3-8
- help 11-56
- high-gloss paper 3-8
- high-gloss photo 3-8
- high-gloss photo paper 3-8
- horizontal misalignment 11-20
- How to perform the Media Test Print 9-8
- HP Coated Paper 3-8
- HP DesignJet CP ink
  - support media types for 3-4
- HP Heavyweight Coated Paper 3-8
- HP High-Gloss Photo Paper 3-8
- HP RTL programming information 13-20
- HP Semi-Gloss Photo Paper 3-8
- HP support services 11-56
- HP-GL/2 Configuration print 2-12
- HP-GL/2 configuration print 8-3
- HP-GL/2 palette 2-13
- HP-GL/2 programming information 13-20
- I**
- I/O time-out setting
  - changing 8-10
- image content 11-46
- image position 11-46
- image quality
  - controlling 9-1, 12-1
  - problems 11-5
  - test 11-5
- image quality print 2-12
  - analyzing 11-10
  - printing 11-8
  - test pattern 1 11-10
  - test pattern 2 11-10
  - test pattern 4 11-20
  - test pattern 5 11-21
  - using 11-8
- image quality test 9-4
- imaging film-backlit 3-8
- imaging ink 1-4, 4-2, 4-4
- inaccurate prints 11-48
- incorrect printing area 11-48
- incorrect prints 11-50
- incorrectly positioned media 11-28
- ink bleeds 11-26
- ink cartridges 4-3
  - removing and replacing 4-19
- ink components 4-12, 11-6
- ink emulation mode
  - selecting 9-2
- ink level
  - monitoring 4-9
- ink system 4-2, 4-12
  - ink cartridges 4-3
  - monitoring ink levels 4-9
  - printhead cleaner 4-3
  - printheads 4-3
  - removing and replacing 4-11
  - replacing 11-34
  - storing used 4-23
- Ink System Error 11-31
- ink system features 1-4
- ink system problems 11-43
- Ink system storage container 13-19
- ink systems, mixing 4-12
- ink, handling 4-24
- inked area 5-3
- interface cables 13-11
- interface specifications 13-10
- internal palettes 6-3
- internal print
  - HP-GL/2 configuration 8-3
  - PostScript configuration 8-2
- internal print files 11-50
- internal prints
  - fonts print 2-12
  - HP-GL/2 palette 2-13
  - image quality 2-12
  - menu 2-13
  - PostScript configuration print 2-12
  - PostScript demo print 2-12
  - service print 2-13
  - usage report 2-12
  - where to find 2-13
- L**
- Laminates 3-5
- lens cover
  - replacing 10-4
- lens maintenance 10-3
- loading a new roll 3-32
- loading a sheet 3-39
  - which edge first 3-39
  - which side up 3-39
- loading media problems 11-55
- long-axis print 11-47
- M**
- maintaining your printer 10-1
- maintenance
  - lens 10-3
- managing your prints 7-1
- margins 5-3, 5-14
  - adjusting 5-12
  - automatic cutting 5-14



- material safety data sheet (MSDS) 13-12
- matte paper 3-8
- matte prints 11-5
- Media
  - Installing a new roll 3-32
  - Laminating 3-5
  - Loading 3-13
  - Unloading 3-42
- media 9-8
  - caring for 3-12
  - compensating for badly cut 3-43
  - incorrectly positioned 11-28
  - loading a new roll 3-32
  - misaligned 11-28
  - supported types 3-4
  - unused 3-12
- media handling problems 11-28
- media jam 11-44
- media problems 11-24
  - handling 11-28
  - loading 11-28
  - roll 11-28
  - sheet 11-28
- media test 9-7
- Media Test Print 9-7
- media test print 9-8
- media types
  - 3M Clear Imaging Media 3-8
  - coated paper 3-8
  - combinations with print quality 3-10
  - for HP DesignJet CP ink 3-4
  - heavy coated paper 3-8
  - high-gloss photo 3-8
  - HP Coated Paper 3-8
  - HP commercial names of 3-8
  - HP Heavyweight Coated Paper 3-8
  - HP High-Gloss Photo Paper 3-8
  - HP Semi-Gloss Photo Paper 3-8
  - imaging film-backlit 3-8
  - opaque vinyl 3-8, 3-12
  - physical characteristics 3-9
  - semi-gloss 3-8
  - supported 3-4
- memory 1-7
- memory problems 11-52
- memory specifications 13-4
- memory upgrades 8-11
- menu graphics
  - description 2-15
- menu print 2-13
  - printing 2-9
- menu system
  - entering 2-8
  - navigating 2-14
  - navigation examples 2-16
- merge 6-9
- mirror image 11-48
- mirror images
  - printing 5-19
- misaligned media 11-28
- miscellaneous problems 11-54
- Missing Ink system 11-31
- monitoring ink level 4-9
- monochrome and color
  - switching between 6-11
- N**
- navigation examples
  - changing color calibration setting 2-17
  - changing drying time 2-26
  - menu system 2-16
- nest problems 11-55
- nesting 7-11
  - and automatic rotation 7-12
  - and margins 7-16
  - and page size 5-7
  - and rotation 7-16
  - choosing the method 7-14
  - if queueing off 7-14
  - pages qualifying for 7-13
  - pages which cannot be rotated 7-13
  - turning on or off 7-14
  - wait time 7-15
  - when used 7-13
- nesting pages 7-11
- network interface
  - changing settings 8-10
  - networks and graphics language 8-9
  - new printhead problems 11-34
  - non-endorsed media 9-10, 11-6
  - non-PostScript files
    - adjusting page size 5-6
  - normal printer use 10-6
- O**
- Obtaining Optimum Refill 4-6
- opaque vinyl 3-8, 3-12
- ordering accessories 13-18
- overlapping lines
  - changing treatment of 6-9
- overlying images 11-49
- P**
- Page Accuracy 5-8
- page format 5-2, 11-51
  - inked area 5-3
  - margins 5-3
  - page size 5-3
- page size 5-3
  - adjusting 5-4
  - and clipped images 5-7
  - and nesting 5-7
- palettes
  - changing colors 6-3
  - changing pen width 6-3
  - changing settings 6-7
  - colors available for 6-6
  - internal 6-3
  - selecting 6-4
  - viewing current settings 6-4
- partial print 11-46
- pausing 7-4
- pen widths
  - changing 6-3
- physical specifications 13-3
- pigmented ink 4-2
- position of image 11-46
- PostScript demo print 2-12
- PostScript configuration print 2-12, 8-2
- PostScript files
  - adjusting page size 5-5

## Index

- PostScript scaling 5-20
  - fit to page 5-21
- power specifications 13-5
- presentation 3-8
- print appearance
  - controlling 6-2
- print clipped 11-47
- print margins using opaque vinyl 5-14
- print mode keys 2-4
- print problems
  - diagnosis 11-7
- print quality
  - changing 6-16
  - combinations with media types 3-10
  - settings 6-14
- print resolution 1-5
- print size 11-52
- printer
  - cleaning 10-2
  - front view 1-9
  - maintaining 10-1
  - rear view 1-9
  - storing and moving 10-7
- printer features 1-2
- printer specifications 13-2
- printer speed 11-54
- printer usage
  - normal 10-6
- printhead cleaner 4-24
- printhead cleaners 4-3
  - removing and replacing 4-16
- printheads 4-3, 11-7
  - aligning 9-5
  - checking 9-6
  - refilling 4-8, 9-5
  - refilling from front panel 4-8
  - removing and replacing 4-13
  - servicing 9-5
- printing
  - current configuration 2-7
  - menu print 2-9
  - mirror images 5-19
  - monochrome 6-10
  - printing area 5-3
  - printing area specifications 13-9
  - prints
    - managing 7-1
  - problem solving 11-3
  - problems with replace ink system 11-34
  - problems, miscellaneous 11-54
  - programming information
    - HP RTL 13-20
    - HP-GL/2 13-20
  - PS scale option 5-20
- Q**
  - queue 7-5
    - deleting a job from 7-9
    - identifying a page in 7-8
    - making copies of a page in 7-10
    - page position in 7-8
    - printing a waiting file 7-7
    - prioritizing a job in 7-9
    - viewing the size of a page in 7-8
- R**
  - recalibrating the printer 8-6
  - refilling printheads 4-8
  - Refills 4-5
  - regulatory notices 13-12
  - removing ink systems 4-29
  - replace ink system 11-34
  - replace ink system problems 11-51
  - replacing lens cover 10-4
  - roll media problems 11-28
  - rotate 11-51
  - rotate print incorrect 11-48
  - rotating images 5-15
    - from front panel 5-15
    - interaction with software 5-17
    - non-PostScript files 5-18
    - PostScript files 5-17
    - with clipped images 5-18
- S**
  - safety specifications 13-8
  - scaling
    - fit to page 5-21
    - printed images 5-20
  - selecting
    - select media 9-8
  - semi-gloss paper 3-8
  - semi-gloss photo 3-8
  - semi-gloss photo paper 3-8
  - service print 2-13
  - sheet media problems 11-28
  - skew tolerance 11-28
    - adjusting 3-43
  - sleep mode 2-6
  - specifications 13-5
    - acoustic 13-6
    - duty cycle 13-4
    - EMC 13-7
    - environmental 13-6
    - functional 13-2
    - ink systems 13-2
    - interface 13-10
    - margins 13-3
    - media sizes 13-2
    - media types 13-2
    - memory 13-4
    - operational 13-6
    - parallel (Bi-Tronics/Centronics) interface 13-10
    - physical 13-3
    - power 13-5
    - printer 13-2
    - printing area 13-9
    - programming
      - languages supported 13-3
    - resolution by print quality setting 13-3
    - safety 13-8
    - storage 13-6
  - stacking media 3-12
  - standby mode 2-6
  - status lights 2-5
  - storage container 4-12
  - storing and moving your printer 10-7
  - storing ink 4-24
  - storing ink systems 4-24
  - storing used ink systems 4-23
  - supplies and accessories
    - how to order 13-20

- supported media types 3-4
- switching between color and monochrome 6-11
- system error 11-52
- T**
- Take Up Reel
  - Core changing 3-35
  - Loading 3-19
  - Media Weight 3-24
  - Panel 3-23
  - problems 11-53
  - Turning on the Take Up Reel 8-12
  - Unloading 3-26
- test media 9-8
- test media selection 9-7
- test print
  - custom media test print 9-8
  - test the printer 11-4
- testing media 9-7
- transport mode
  - selecting 10-7
- troubleshooting
  - color accuracy 11-21
  - color alignment 11-20
  - color misalignment 11-15
  - color variation 11-21
  - communication problems 11-45
  - graining 11-5
  - ink system problems 11-43
  - loading media 11-28
  - matte color 11-5
  - media problems 11-28
  - rotation 11-48
  - unexpected color 11-6
- U**
- unexpected color 11-6
- unused media 3-12
- upgrading memory 8-11
- usage report print 2-12
- UV pigmented ink 1-4, 4-4
  - HP DesignJet CP Ink System UV 4-2
- V**
- vertical misalignment 11-20
- vinyl 3-8
- W**
- warped lines 11-26
- warped media 11-26
- warranty statement 37
- world wide warranty 37



# Please Give Us Your Feedback on the Quality of This Documentation

If mailing to the address  
in the USA (see over), fill  
out *this sheet*.

If mailing to the address in  
Spain, fill out *the other  
sheet*.

Name:

Job Title:

Organization:

Address:

Phone:

Alternatively, you can fax this  
form to:  
USA (1) 619 655 6640,  
Attn: HP DesignJet Marketing  
Dept. *or*  
Spain (34) 93 582 2848,  
Attn: Learning Products Dept.

*Please circle the appropriate score*

*Poor*



*Excellent*

Overall ease of use

1

2

3

4

5

Use of language

1

2

3

4

5

Use of graphics

1

2

3

4

5

Please explain any low score:

Any other comments concerning the documentation accompanying this product:

◀ ◀ ◀ **Any comments?**

▼ Fold here and then staple or tape the ends together ▼



NO POSTAGE  
NECESSARY  
IF MAILED  
IN THE  
UNITED STATES

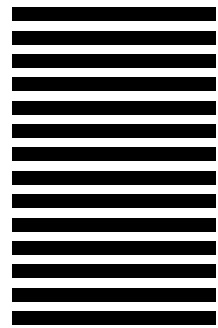

BUSINESS REPLY MAIL  
FIRST CLASS MAIL PERMIT NO. 24343 SAN DIEGO, CA

POSTAGE WILL BE PAID BY ADDRESSEE



HP DesignJet Marketing Center  
Hewlett-Packard Company  
Building #7  
16399 West Bernado Drive  
San Diego, CA 92127  
U.S.A.



# Please Give Us Your Feedback on the Quality of This Documentation

If mailing to the address  
in Spain (see over), fill  
out *this sheet*.

Name:

If mailing to the address in  
the USA, fill out *the other  
sheet*.

Job Title:

Organization:

Address:

Alternatively, you can fax this  
form to:  
**USA (1) 619 655 6640,  
Attn: HP DesignJet Marketing  
Dept. or  
Spain (34) 93 582 1400,  
Attn: Learning Products Dept.**

Phone:

*Please circle the appropriate score*

*Poor*



*Excellent*

Overall ease of use

1

2

3

4

5

Use of language

1

2

3

4

5

Use of graphics

1

2

3

4

5

Please explain any low score:

Any other comments concerning the documentation accompanying this product:



**Any comments?**



Fold here and then staple or tape the ends together



Hewlett-Packard Company  
Barcelona Division  
*Attn: Learning Products Dept.*  
Avda. Graells, 501  
08190 Sant Cugat del Vallès  
**Spain**



---

# **3M<sup>TM</sup> MCS<sup>TM</sup> Warranty for Graphics Produced on HP DesignJet CP Printers**

Graphics made with 3M<sup>TM</sup> Changeable Opaque Imaging Media 8522CP, HP DesignJet CP Ink System UV and 3M Luster Overlamine 8519CP or 3M Matte Overlamine 8520CP, by 3M TIJ Graphics Certified Fabricators on HP DesignJet CP printers and according to manufacturers recommendations, are warranted for 12 months outdoors and 5 years indoors. These graphics are covered against failure caused by ultraviolet light, moisture, temperature extremes, pollution, and other elements. If a graphic fails to perform in accordance with 3M product specifications within this time frame, 3M will replace the materials at no charge. These remedies are exclusive. In no case shall 3M be liable for any direct, indirect or consequential damages, including any labor charges.

Only 3M TIJ Graphics Certified Fabricators are eligible to offer MCS<sup>TM</sup> warranted graphics. In order to become certified, a fabricator must complete the requirements as specified in the 3M Thermal InkJet Graphics Certified Fabricators Starter Kit 8590CP.

See 3M product bulletins and the World Wide Warranty bulletin for details on supported products, graphic constructions and warranty coverage.

3M™ MCS™ Warranty for Graphics Produced on HP DesignJet CP Printers

---

# Hewlett-Packard Limited Warranty Statement

HP Product	Duration of Limited Warranty
Software:	90 Days
Ink Cartridges:	90 Days
Printheads:	90 Days
Printer and Related HP Hardware:	1 Year

## A. Extent of Limited Warranty

1. Hewlett-Packard (HP) warrants to the end-user customer that the HP products specified above will be free from defects in materials and workmanship for the duration specified above, which duration begins on the date of purchase by the customer. Customer is responsible for maintaining proof of date of purchase.
2. For software products, HP's limited warranty applies only to a failure to execute programming instructions. HP does not warrant that the operation of any product will be uninterrupted or error free.
3. HP's limited warranty covers only those defects which arise as a result of normal use of the product, and do not apply to any:
  - a. Improper or inadequate maintenance or modification;
  - b. Software, interfacing, media, parts, or supplies not provided or supported by HP; or
  - c. Operation outside the product's specifications.
4. For HP printer products, the use of a non-HP ink cartridge or a refilled ink cartridge does not affect either the warranty to the customer or any HP support contract with the customer. However, if printer failure or damage is attributable to the use of a non-HP or refilled ink cartridge, HP will charge its standard time and materials charges to service the printer for the particular failure or damage.
5. If HP receives, during the applicable warranty period, notice of a defect in any software, media, or ink cartridge product which is covered by HP's warranty, HP shall replace the defective product. If HP receives, during the applicable warranty period, notice of a defect in any hardware product which is covered by HP's warranty, HP shall either repair or replace the defective product, at HP's option.
6. If HP is unable to repair or replace, as applicable, a defective product which is covered by HP's warranty, HP shall, within a reasonable time after being notified of the defect, refund the purchase price for the product.
7. HP shall have no obligation to repair, replace, or refund until the customer returns the defective product to HP.
8. Any replacement product may be either new or like-new, provided that it has functionality at least equal to that of the product being replaced.
9. HP products may contain remanufactured parts or components equivalent to new in performance or may have been subject to incidental use.
10. HP's limited warranty is valid in any country where the covered HP product is distributed by HP except for the Middle-East, Africa, Argentina, Brazil, Mexico, Venezuela, and France's "Departements D'Outre-Mer"; for those excepted areas, the warranty is valid only in the country of purchase. Contracts for additional warranty services, such as on-site service, may be available for any authorized HP service facility where the listed HP product is distributed by HP or an authorized importer.

## B. Limitations of Warranty

1. TO THE EXTENT ALLOWED BY LOCAL LAW, NEITHER HP NOR ITS THIRD PARTY SUPPLIERS MAKE ANY OTHER WARRANTY OR CONDITION OF ANY KIND, WHETHER EXPRESS OR IMPLIED, WITH RESPECT TO THE HP PRODUCTS, AND SPECIFICALLY DISCLAIM THE IMPLIED

WARRANTIES OR CONDITIONS OF MERCHANTABILITY, SATISFACTORY QUALITY, AND FITNESS FOR A PARTICULAR PURPOSE.

## C. Limitations of Liability

1. TO THE EXTENT ALLOWED BY LOCAL LAW, EXCEPT FOR THE OBLIGATIONS SPECIFICALLY SET FORTH IN THIS WARRANTY STATEMENT, IN NO EVENT SHALL HP OR ITS THIRD PARTY SUPPLIERS BE LIABLE FOR DIRECT, INDIRECT, SPECIAL, INCIDENTAL, OR CONSEQUENTIAL DAMAGES, WHETHER BASED ON CONTRACT, TORT, OR ANY OTHER LEGAL THEORY AND WHETHER ADVISED OF THE POSSIBILITY OF SUCH DAMAGES.

## D. Local Law

1. To the extent allowed by local law, the remedies provided in this Warranty Statement are the customer's sole and exclusive remedies.
2. This Warranty Statement gives the customer specific legal rights. The customer may also have other rights which vary from state to state in the United States, from province to province in Canada, and from country to country elsewhere in the world.
3. To the extent that this Warranty Statement is inconsistent with local law, this Warranty Statement shall be deemed modified to be consistent with such local law. Under such local law, certain disclaimers and limitations of this Warranty Statement may not apply to the customer. For example, some states in the United States, as well as some governments outside the United States (including provinces in Canada), may:
  - a. Preclude the disclaimers and limitations in this Warranty Statement from limiting the statutory rights of a consumer (e.g. the United Kingdom).
  - b. Otherwise restrict the ability of a manufacturer to enforce such disclaimers or limitations; or
  - c. Grant the customer additional warranty rights, specify the duration of implied warranties which the manufacturer cannot disclaim, or not allow limitations on the duration of implied warranties.
4. FOR CONSUMER TRANSACTIONS IN AUSTRALIA AND NEW ZEALAND, THE TERMS IN THIS WARRANTY STATEMENT, EXCEPT TO THE EXTENT LAWFULLY PERMITTED, DO NOT EXCLUDE, RESTRICT, OR MODIFY, AND ARE IN ADDITION TO, THE MANDATORY STATUTORY RIGHTS APPLICABLE TO THE SALE OF HP PRODUCTS TO SUCH CUSTOMERS.

Revision: May 15th, 1998

## About this edition

Edition dates are as follows:

First edition, July 1998

New editions are complete revisions of the manual. Change sheets, which may be issued between editions, contain additional information. The dates on the title page change only when a new edition is published. Minor corrections that do not affect the function of the product may be made at reprint without a change to the print date.

Many product updates and fixes do not require manual changes and, conversely, manual corrections may be done without accompanying product changes. Therefore, do not expect a one to one correspondence between product updates and manual revisions.

**For support details, see the section "Getting Help" in chapter 11.**

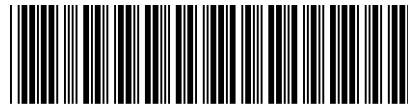

**C4704-90241**

Manual Part Number: C4704-90241  
English  
Printed in Europe