

**hp officejet
d series**

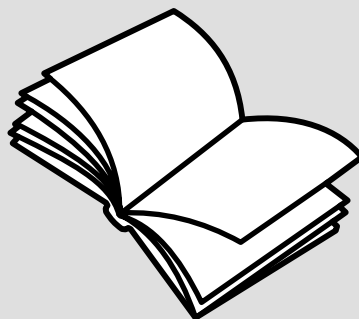

i n v e n t



reference guide

© Copyright Hewlett-Packard Company 2002

All rights are reserved. No part of the document may be photocopied, reproduced, or translated to another language without the prior written consent of Hewlett-Packard Company.

Portions Copyright © 1989-2002 Palomar Software Inc. The HP OfficeJet D Series includes printer driver technology licensed from Palomar Software, Inc. www.palomar.com

Copyright © 1999-2002 Apple Computer, Inc.

Apple, the Apple logo, Mac, Mac logo, Macintosh, and Mac OS are trademarks of Apple Computer, Inc., registered in the U.S. and other countries.

Publication number: C8373-90101

First edition: September 2002

Printed in U.S.A., Mexico, Germany, Singapore, or China

Windows®, Windows NT®, Windows ME®, Windows XP®, and Windows 2000® are U.S.-registered trademarks of Microsoft Corporation.

Intel® and Pentium® are registered trademarks of Intel Corporation.

notice

The information contained in this document is subject to change without notice and should not be construed as a commitment by the Hewlett-Packard Company.

Hewlett-Packard assumes no responsibility for any errors that may appear in this document, nor does it make expressed or implied warranty of any kind with regard to this material, including, but not limited to, the implied warranties of merchantability and fitness for a particular purpose.

The Hewlett-Packard Company shall not be liable for incidental or consequential damages in connection with, or arising out of the furnishing, performance, or use of this document and the program material which it describes.

Note: Regulatory information can be found in the "Technical information" section of the Support and Specifications Booklet.



It is not lawful in many places to make copies of the following items. When in doubt, check with a legal representative first.

- Governmental paper or documents:
 - Passports
 - Immigration papers
 - Selective service papers
 - Identification badges, cards, or insignias
- Governmental stamps:
 - Postage stamps
 - Food stamps
- Checks or drafts drawn on Governmental agencies
- Paper currency, traveler's checks, or money orders
- Certificates of deposit
- Copyrighted works

safety information



Warning! To prevent fire or shock hazard, do not expose this product to rain or any type of moisture.

Always follow basic safety precautions when using this product to reduce risk of injury from fire or electric shock.

WARNING: potential shock hazard

- 1 Read and understand all instructions in the setup poster.
- 2 Use only a grounded electrical outlet when connecting the unit to a power source. If you do not know whether the outlet is grounded, check with a qualified electrician.
- 3 Observe all warnings and instructions marked on the product.
- 4 Unplug this product from wall outlets before cleaning.
- 5 Do not install or use this product near water or when you are wet.
- 6 Install the product securely on a stable surface.
- 7 Install the product in a protected location where no one can step on or trip over the line cord, and where the line cord will not be damaged.
- 8 If the product does not operate normally, see the online Troubleshooting help.
- 9 No operator-serviceable parts inside. Refer servicing to qualified service personnel.
- 10 Use in a well-ventilated area.

contents

1	get help	1
2	quick start	3
	tutorial	3
	before you begin	3
	front panel features	4
	make a copy	5
	enhance your copy	5
	copy from the automatic document feeder	6
	menu button review	7
	front panel overview	7
	use your hp officejet with a computer	9
	review the hp director	9
	hp officejet menu functions	12
3	load originals and load paper	13
	load originals	13
	load originals on the glass	13
	load originals in the automatic document feeder	14
	load paper	15
	load envelopes	17
	tips for loading other types of paper in the main tray	18
	choose the paper tray and set the paper type	20
	set the paper size	20
	learn more	20
4	use the scan features	21
	scan an original	21
	scan to a different software program	22
	stop scanning	23

- learn more 23
- 5 use the copy features 25**
 - make copies 25
 - make a copy 25
 - increase copy speed or quality 26
 - reduce or enlarge a copy. 26
 - make copies lighter or darker 26
 - change color intensity 27
 - enhance text sharpness and photo colors 27
 - set the number of copies 27
 - change settings for all copy tasks 27
 - perform special copy jobs. 28
 - copy a photo 28
 - fit a copy to the page 28
 - print several copies on one page 29
 - print two originals on one page 30
 - shift image to increase the margin. 30
 - make two-sided copies. 31
 - make a poster 32
 - prepare a color t-shirt transfer. 33
 - stop copying 33
 - learn more 33
 - copy setup menu options 34
- 6 maintain your hp officejet. 35**
 - clean the glass 35
 - clean the lid backing 35
 - clean the exterior. 36
 - install the automatic document feeder tray. 36
 - work with printheads and ink cartridges 36
 - print a self-test report 36
 - check the ink level. 37
 - perform color calibration 37
 - handle printheads. 37
 - verify a printhead needs to be replaced. 38
 - replace the printheads. 39
 - handle ink cartridges. 41
 - replace the ink cartridges. 42
 - align the printheads 44
 - clean the printheads 44
 - clean the ink cartridge contacts. 44
 - clean the printhead contacts. 46

replacement alternatives	47
override the ink level gauge	48
restore factory defaults	49
set the country or language	49
set the power save mode time	50
maintenance menu options	51
7 additional setup information	53
possible installation problems	53
connect your hp officejet to your computer	55
connect your parallel cable adapter	55
setup for simple sharing	56
connect your usb port	56
remove and reinstall your hp officejet software	57
learn more	58
index	59

get help

1

help	description	win	mac
Setup Poster	The Setup Poster provides instructions for setting up and configuring your HP OfficeJet. Make sure you use the correct poster for your operating system (Windows or Macintosh).	X	X
Product Tour	The tour provides a brief introduction to the HP OfficeJet and its capabilities, so you can start using it immediately. You can take the tour immediately after installing the HP OfficeJet software, or to take the tour at any time, do the following: <ol style="list-style-type: none">1 Double-click the HP OfficeJet D Series shortcut on the Windows desktop.2 In the HP Director, click Help, then choose Product Tour.3 After the Product Tour dialog box appears, insert the HP OfficeJet D Series CD-ROM into your computer's CD-ROM drive, and click Search.	X	
User's Guide	The onscreen User's Guide provides detailed information on using your HP OfficeJet and its features. It also provides detailed information on topics ranging from paper types to using other programs with your HP OfficeJet. For Windows users: Go to the Director , click Help , and then choose User's Guide . For Macintosh users: Go to the Director , click Tools , and then choose View Onscreen Guide .	X	X
Reference Guide	This printed Reference Guide contains information on using your HP OfficeJet and provides additional troubleshooting assistance for the installation process.	X	X
Support and Specifications booklet	The printed Support and Specifications booklet provides information for your HP OfficeJet, including how to order supplies and accessories, technical specifications, support, and warranty information.	X	X

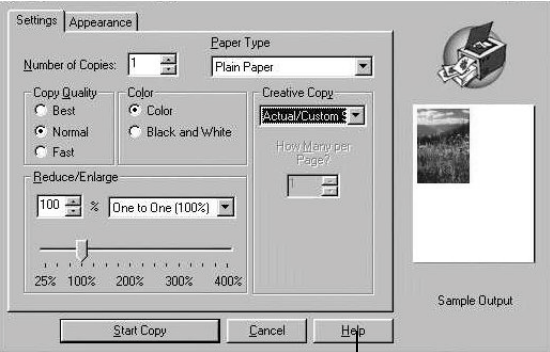
help	description	win	mac
Troubleshooting help	To access troubleshooting information, go to the Director , click Help , then choose Troubleshooting . Troubleshooting is also available via the Help button that appears on some error messages.	X	
Internet help and technical support	If you have Internet access, you can get help from the HP website at: <p style="text-align: center;">www.officejetsupport.com</p> The website also provides answers to frequently-asked questions.	X	X
Readme file	After you install your software, you can access the Readme file from either the HP OfficeJet D Series CD-ROM or the HP OfficeJet D Series program folder. To access the Readme file, do the following: For Windows: go to the Windows taskbar, click Start , point to Programs or All Programs (XP) , point to Hewlett-Packard , point to HP OfficeJet D Series , and then choose View the Readme File . For Macintosh: go to the HD:Applications:HP OfficeJet Software folder.	X	X
Dialog-box help	<p>For Windows: Clicking Help in a dialog box displays information about options and settings within the dialog box.</p>  <p>To get help while working in a dialog box, click Help.</p>	X	
Accessories guide	The Accessories guide provides information on attaching and setting up the HP 250-sheet plain paper tray, as well as how to load paper into it. It also includes information about the two-sided printing accessory.	X	X

quick start

2

You can perform many functions using either the front panel or the HP OfficeJet software.

Even if you do not connect your HP OfficeJet to a computer, you can use the front panel to copy or print documents. You can change a wide variety of settings using the front-panel buttons and menu system.

tutorial

This brief tutorial teaches you how to use your HP OfficeJet to make a copy, adjust copy settings, and change settings. This is not a comprehensive tutorial; its purpose is to familiarize you with the front panel and the different buttons. It should take about ten minutes to complete the tutorial, after which you can experiment on your own.



We highly recommend that you take this tutorial before you start using your HP OfficeJet for daily tasks.

Review the table of contents or the index to find out about the other front-panel tasks covered in this Reference Guide.

before you begin

Do the following:

- Follow the instructions in the Setup Poster to set up your HP OfficeJet. You should install the HP OfficeJet software before connecting the HP OfficeJet to the computer.
- Make sure paper is loaded in the main tray. If you need more information, see **load paper** on page 15.
- Have available a color photograph or picture that is smaller than Letter or A4 size. You will use this image for tutorial activities.
- Obtain a two or three-page document. You will use it for tutorial activities.

front panel features

The front panel is divided into the following main regions:

- Keypad
- Shared buttons and front-panel display
- Copy area
- Scan area
- On button

Review the illustrations below and identify the location of the buttons on the front panel. You will not use all of the front-panel features in the tutorial, but you may find it helpful to note the locations of all the buttons.

Left side of the front panel

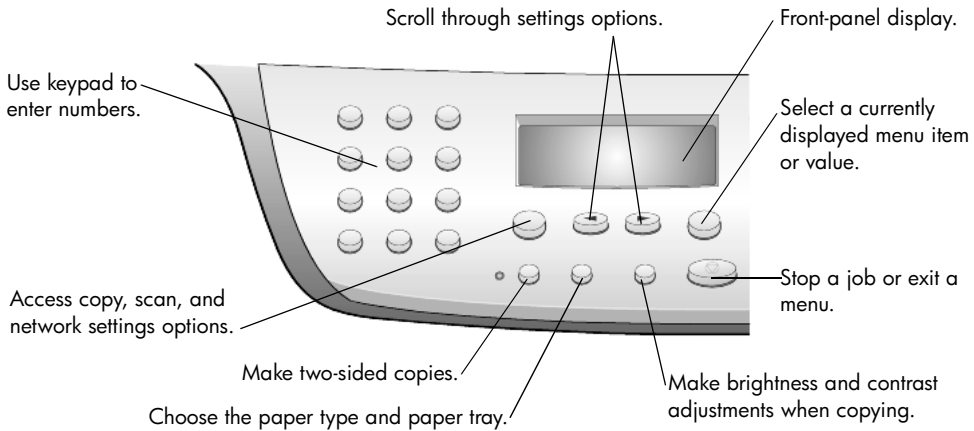

Right side of the front panel

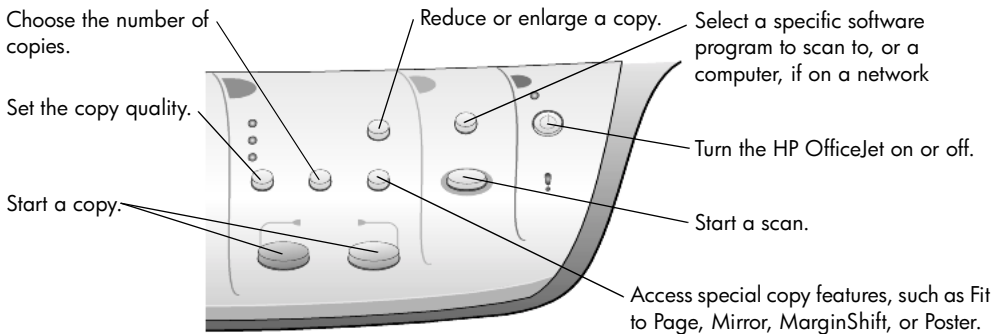

make a copy

Follow the instructions below to make a copy of your color photo or picture.

- 1 Open the lid of your HP OfficeJet and place your picture face down in the bottom-right corner of the scanner glass with the sides of the picture touching the right and bottom edges.

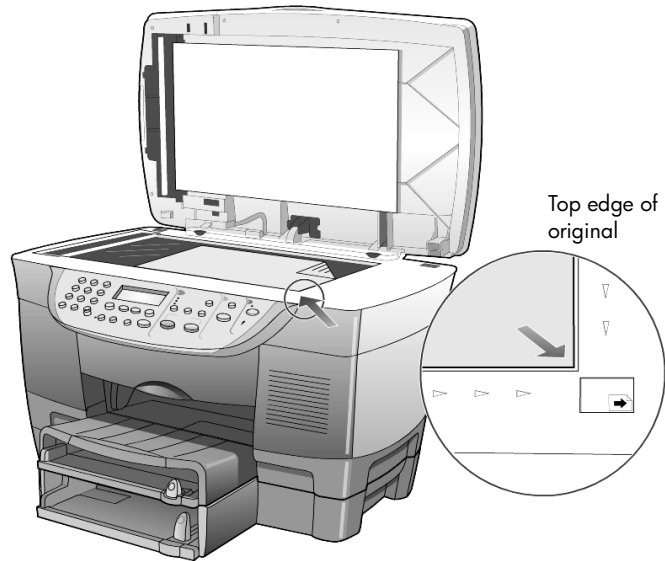

- 2 In the **Copy** area of the front panel, press **Start Copy, Color**.
If you had wanted to save the picture to the computer, you would have pressed **Start Scan**. For this tutorial, you will continue making a copy.

The default is a single copy. Pressing the **Start Copy, Color** button on the HP OfficeJet automatically prints one color copy of the picture on the glass. If you had pressed the **Start Copy, Black** button, the HP OfficeJet would have made a single grayscale copy of your color picture.

enhance your copy

- 1 Without moving your photo or picture from the glass, press the **Number of Copies** button two times until **2 Copies** is showing.
- 2 Press **Start Copy, Black** on the front panel.
The HP OfficeJet makes two black and white copies of your picture.
Notice that you did not have to do anything else but select the number of copies and press a start key. Now you will change an additional setting before making more copies.
- 3 Press **Number of Copies** one more time to increase the copies to 3.
- 4 Press the **Reduce/Enlarge** button.
Custom 100% appears in the front-panel display.
Use this option to reduce or enlarge your picture.

- 5 Press **5** and then the **0** button on the keypad so that 50% appears, then press **Enter**.
- 6 Press **Color** on the front panel.
The HP OfficeJet prints three color copies of your picture, reduced by 50%.
If you do not do anything else with your HP OfficeJet, the settings that you adjusted will return to their default settings within two minutes. The number of copies returns to one and the copy percentage returns to 100%.
- 7 If you do not want to wait, press **Cancel**.
Next you will use one of the **Special Features** options to enlarge your photograph.
- 8 Press **Special Features** until **Fit to Page** appears.
- 9 Press **Enter**.
- 10 Press **Start Copy, Black** or **Start Copy, Color**.
A copy of your picture is printed, which fills the whole page.
Next, you will review the automatic document feeder.

copy from the automatic document feeder

Your HP OfficeJet has an automatic document feeder (ADF), which you can use to load multiple originals for faster copying or scanning. In the next part of this tutorial, you are going to make a fast copy of your two or three-page document.

- 1 Remove the photo from the glass.
- 2 Place the two or three originals face-up in the automatic document feeder.
- 3 Adjust the paper-width guide to fit the size of your original.
A message appears on the front-panel display indicating that the originals are loaded.

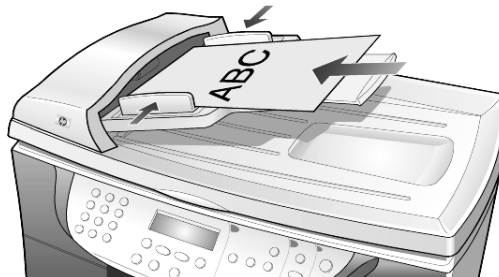

- 4 Press the **Quality** button until **Fast** is lit.
- 5 Press **Start Copy, Black** or **Start Copy, Color**.
The documents are fed through the ADF and are quickly copied.
Next, you will review the **Menu** button.

menu button review

The **Menu** button lets you enter the menu system that you use to change copy settings, as well as perform maintenance and print reports.

- 1 Press **Menu**.
The first submenu appears, which depends on what model of HP OfficeJet you have.
- 2 Press **Menu** repeatedly to view all the submenus.
The submenus are as follows:
 - 1: Copy Setup
 - 2: Print Report
 - 3: Status and Maintenance
 - 4: Network Setup (if network hardware is installed, advanced users only)
 Some options are available only on certain models of your HP OfficeJet.
- 3 Press **Menu**.
- 4 Press **3**, then press **1**.
This selects **Status and Maintenance**, then selects the **Check Ink Level**.
The ink supply levels for both the black ink cartridge and the tri-color ink cartridge appear in the front-panel display.
- 5 Press **Cancel** to clear the front-panel display, if desired.
This concludes the brief tutorial.
Review the rest of this Reference Guide to find out how to make other changes and use other features.

front panel overview

Left side of the front panel

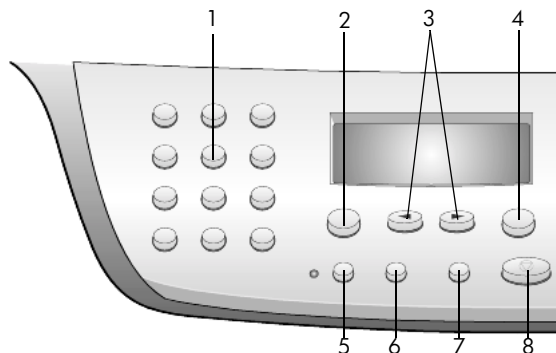

Right side of the front panel

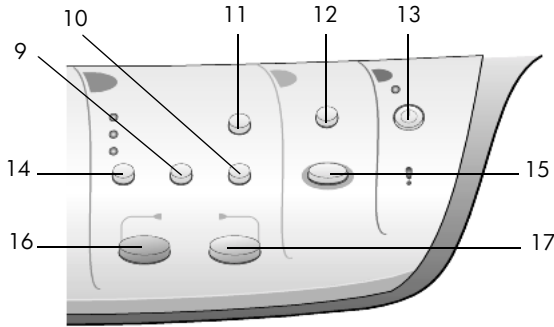

feature	purpose
1	Keypad: use to enter numbers such as the quantity of copies or percentages when reducing or enlarging.
2	Menu: use to access the menu system. The menus that are available depend which model of the HP OfficeJet you have. Menu options include; Copy Setup, Print Report, Status & Maintenance, and Network Setup.
3	Arrows: use to scroll through menu settings or through options within settings.
4	Enter: use to select or save the displayed setting.
5	Two-Sided Copy: use to make hands-free two-sided copies. Available only if you have the two-sided printing accessory and the automatic document feeder (ADF).
6	Tray Select/Paper Type: use to select the paper type. The main paper tray supports plain paper and specialty papers. Use this button to select both the paper type and the paper tray to use.
7	Lighter/Darker: use to adjust the lightness and darkness of the copies you make.
8	Cancel: use to stop a job, exit a menu, or exit button settings.
9	Number of Copies: use to change the number of copies for this copy job. This button can be used in conjunction with the arrow keys or the keypad to make additional copies.
10	Special Features: use to access options that let you reduce or enlarge to a specified copy image size on paper loaded in the selected tray. The options are Normal, Fit to Page, Which Size?, Poster, 2 on 1, MarginShift and Mirror.
11	Reduce/Enlarge: use to reduce or enlarge an original to a specified image size on paper loaded in the selected tray. The original may be fed from the automatic document feeder (ADF) or placed on the glass.

feature	purpose
12	Scan To: use to access a list of software programs that an image can be scanned to. You must configure the Scan To list using the HP OfficeJet software on the PC prior to using this feature.
13	On: turns the HP OfficeJet on and off.
14	Quality: use to select the quality of the copy from Best, Normal, or Fast.
15	Start Scan: use to start the scan of an original from the ADF or the glass to the designated Scan To destination. If no change was made to the Scan To destination, the image will be scanned to the HP Photo View Center (Windows) or HP Scan Window (Macintosh) if the HP OfficeJet software is installed.
16	Start Copy - Black: use to start a black and white copy.
17	Start Copy - Color: use to start a color copy.

use your hp officejet with a computer

If you installed the HP OfficeJet software on your computer according to the Setup Poster, you can access all the features of the HP OfficeJet using the HP Director.

review the hp director

The HP Director is available through the desktop shortcut.

For **Windows Users:** Do one of the following:

- Double-click the **HP OfficeJet D Series** shortcut on the Windows desktop.
- In the Windows taskbar, click **Start**, point to **Programs** or **All Programs (XP)**, point to **Hewlett-Packard**, choose **HP OfficeJet D Series**, then choose **HP Director**.

For **Macintosh Users:** Double-click the **HP Director** icon on the desktop.

See the *HP OfficeJet D Series: onscreen User's Guide* for comprehensive onscreen information about the Director.

For **Windows Users:** Go to the **HP Director**, click **Help**, and then choose **User's Guide**.

For **Macintosh Users:** Go to the **HP Director**, click **Tools**, and then choose **View Onscreen Guide**.

The following figure shows some of the features available through the HP Director for Windows.

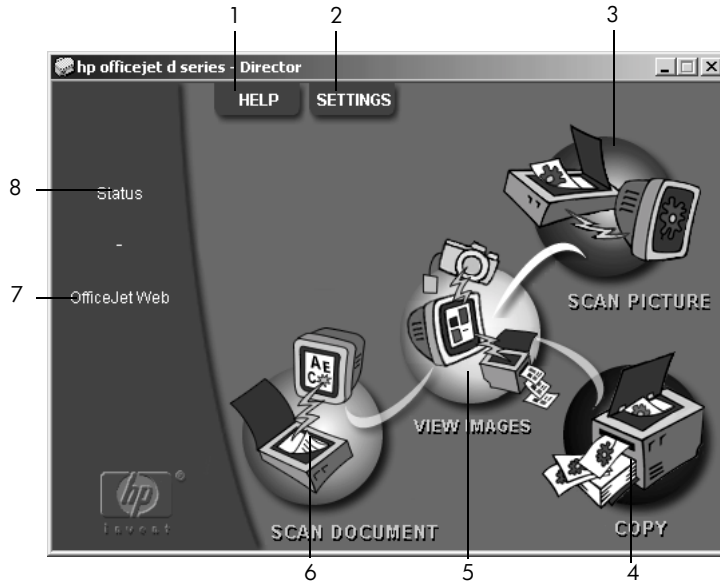

the director for microsoft windows operating systems

feature	purpose
1	Help: provides access to onscreen assistance in the form of an onscreen User's Guide, Troubleshooting, Product Tour, Director Help, and information about your HP OfficeJet.
2	Settings: displays dialog boxes that allow you to view or change various settings for print, scan, copy, Director, and maintenance.
3	Scan Picture: scans a picture and displays it in the HP Photo View Center after first previewing it in the HP Image Viewer.
4	Copy: displays the Copy dialog box where you can select the paper type, number of copies, the color, the size, the Creative Copy features, and start a copy.
5	View Images: displays the Photo View Center, where you can view and edit images, use creative printing, make and print a photo album, print or e-mail an image, upload an image to the web, or save an image.
6	Scan Document: scans the document and displays it in the HP Image Viewer for previewing. After you accept the preview, the document is scanned into the text editing program that you have set up.
7	OfficeJetWeb: launches your browser and accesses the HP OfficeJet website.
8	Status: displays the status window.

The following figure shows some of the features available through the HP Director for Macintosh. Consult the legend for a brief explanation of a specific feature.

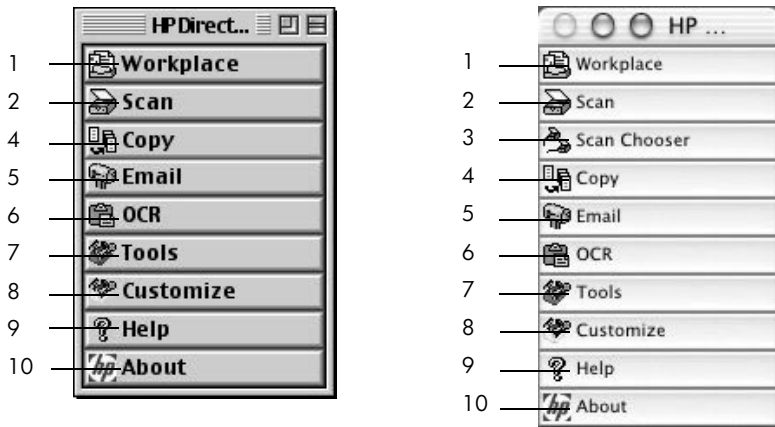

the director for macintosh, in os9 and osx

feature	purpose
1	Workplace: displays the HP Workplace, where you can view thumbnails, view and edit images, print single or multiple photos.
2	Scan: scans a document or photo into the HP Scan Window, where you can select a destination.
3	Scan Chooser: provides a short cut to the chooser, where you can select the HP OfficeJet D Series as the scanning device.
4	Copy: copies in black and white or color.
5	Email: scans a document or photo and attaches it to an e-mail message.
6	OCR: scans a document and converts it to text for editing in a word processor.
7	Tools: accesses the Toolbox, which you can use to maintain and configure the HP OfficeJet D Series.
8	Customize: displays options for customizing the appearance and functionality of the Director and scanning.
9	Help: accesses Help for assistance with the HP OfficeJet software.
10	About: accesses copyright information about the HP OfficeJet software.

hp officejet menu functions

Access **Menu** functions by pressing the corresponding numbers for each menu option. For example: to set the language and country/region, press **Menu**, then press **3** and **7**. This automatically selects the **Status and Maintenance** menu, then selects the **Set Country and Language** option.

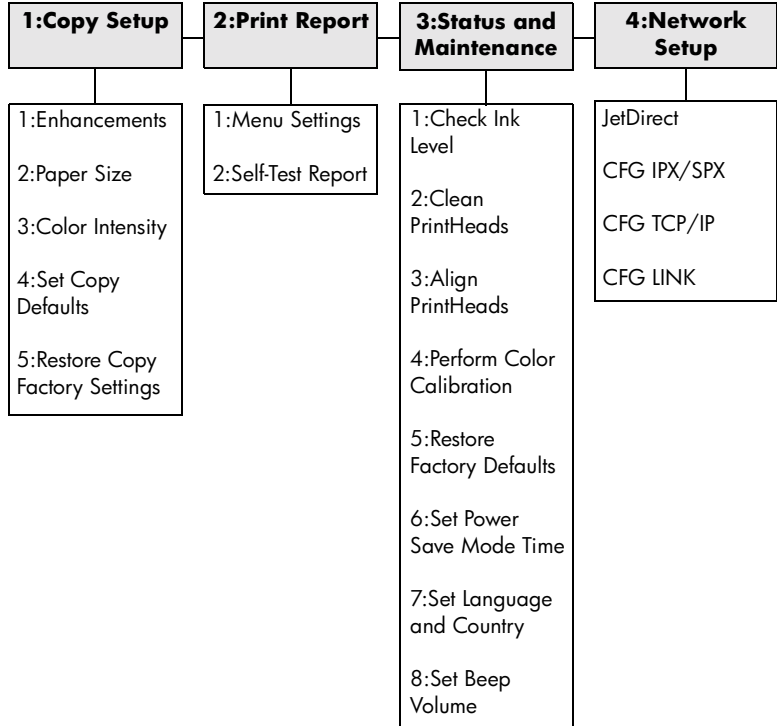

Press **Menu** to display the menu functions.
Press **◀** or **▶** to move to the setting you want.
Press **Enter** to select the displayed setting.

load originals and load paper

3

You can copy from originals loaded on the glass or in the automatic document feeder. You can also print and copy onto a variety of paper types, weights, sizes, and transparency films. It is important, however, that you choose the right paper and make sure that it is loaded correctly and not damaged.

load originals

Your HP OfficeJet provides two ways to load originals for copying and scanning. You can do the following:

- Load originals on the glass
- Load originals in the automatic document feeder

load originals on the glass

You can copy or scan any original by placing it on the glass.



Many of the **Special Features** options, such as **Which Size?** or **Poster**, will not work correctly if the glass and lid backing are not clean. For more information, see **clean the glass** and **clean the lid backing** on page 35.

- 1 Lift the lid and place the original face down on the glass in the bottom-right corner with the sides of the originals touching the right and bottom edges.
It is important to use the bottom-right corner when using the copy or scan feature.

Tip! If you are copying from a transparency (that is, your original is printed on transparency film), place a blank piece of paper on top of the transparency.

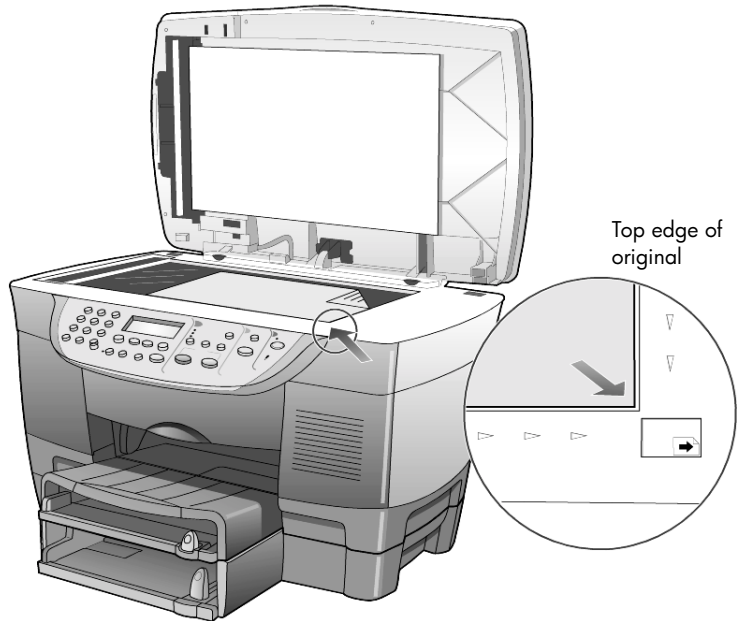

2 Close the lid.

load originals in the automatic document feeder

Your HP OfficeJet has an automatic document feeder (ADF), which you can use to load up to 30 originals of the following paper types:

- Plain Paper
16 to 36 lb. long grain only
- Specialty Paper
 - HP Premium Inkjet Paper
 - HP Bright White Inkjet Paper

You can also use the ADF to load the following types of originals, but you must load them one sheet at a time:

- Other specialty papers, such as glossy paper
- Overhead transparencies, such as HP Premium Inkjet Transparency Media
- Photo paper, such as Kodak EktaColor Edge-5 (glossy)
- Real Estate paper (single sheet only)

1 Place all originals in the ADF print side up.

2 Adjust the paper-width guide to fit the size of your original.

A message appears on the display indicating that the originals are loaded.

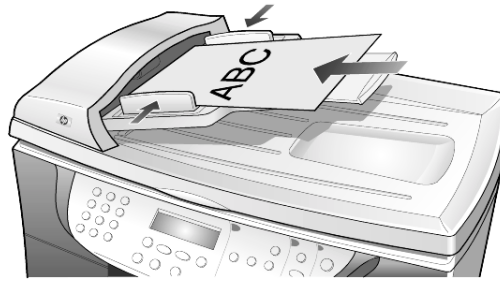

load paper

Following is the basic procedure for loading paper. There are specific considerations for loading certain types of paper, transparency film, and envelopes. After you review this procedure, see **tips for loading other types of paper in the main tray** on page 18 and **load envelopes** on page 17.

For best results, adjust the paper settings each time you change paper types or paper sizes. For more information, see **choose the paper tray and set the paper type** on page 20.

If you have the HP 250-sheet plain paper tray, you can load paper into both the main paper tray and the 250-sheet plain paper tray. If you have the 250-sheet plain paper tray, you should use it for plain paper only. Please refer to the Accessories guide that comes with the paper tray for information about installing the tray, loading paper, and adjusting paper-width and paper-length guides.

Caution! You must also have the two-sided printing accessory installed to use the 250-sheet plain paper tray.

to load the main paper tray

- 1 Lift the output tray up until it catches in the raised position, and slide the paper-width and paper-length guides to their outermost positions.

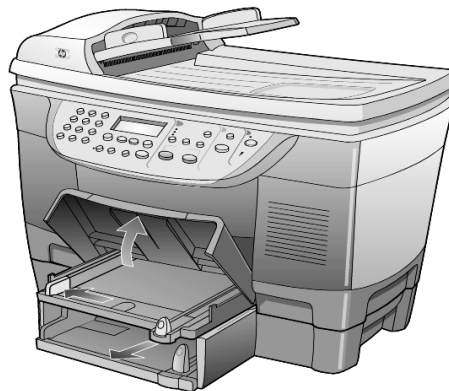

- 2 Tap the stack on a flat surface to align the edges of the paper, and then check the paper for the following:
 - Make sure it is free of rips, dust, wrinkles, and curled or bent edges.
 - Make sure all the paper in the stack is the same size and type, unless you are working with photo paper.
- 3 Insert paper into the main tray print-side down until it stops. If you are using letterhead, insert the top of the page first.

Be careful not to use too much or too little paper. Check that the stack of paper contains several sheets but is no higher than the top of the paper-length guide.

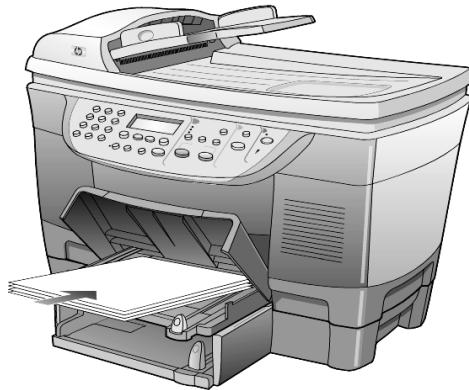

- 4 Slide the paper-width and paper-length guides in until they stop at the edges of the paper. Make sure that the paper stack lies flat in the main tray and fits under the tab of the paper-length guide.
- 5 Lower the output tray.
- 6 To prevent printed paper from falling off the tray, fully extend the output-tray extender.

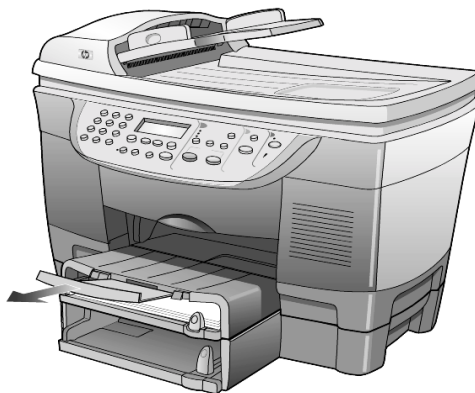

To load the 250-sheet plain paper tray

- ▶ Review the Accessories guide that came with the 250-sheet plain paper tray for information on loading paper in this accessory.

load envelopes

Your HP OfficeJet provides two methods for working with envelopes. Do *not* use shiny or embossed envelopes, or envelopes that have clasps or windows.

- If you are printing one envelope, slide the envelope into the envelope slot, which is located on the right side toward the back of the output tray. Insert the envelope with the flap up and on the left, as shown in the illustration. Slide the envelope on the top until it stops.

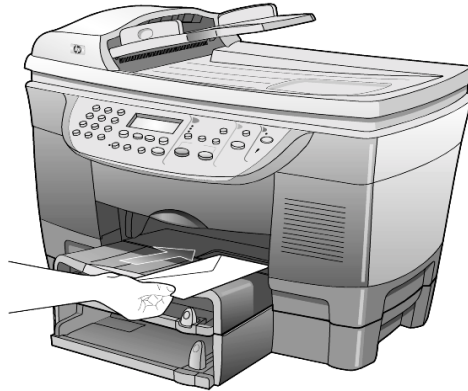

- If you are printing multiple envelopes, remove all paper from the main tray, and then slide a stack of envelopes into the tray, with the envelope flaps up and to the left (print-side down), until they stop.

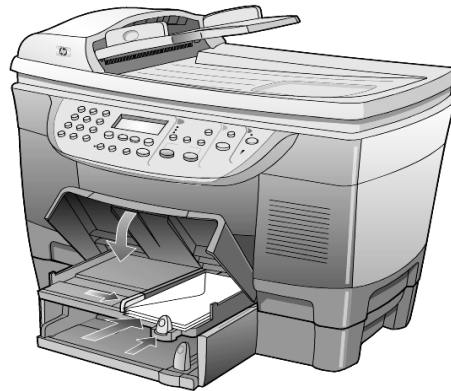

Adjust the paper-width guide against the envelopes (be careful not to bend the envelopes). Make sure the envelopes fit within the tray (do not overload it).

Consult the help files in your word processing software for details on how to format text for printing on envelopes.

tips for loading other types of paper in the main tray

The following table provides guidelines for loading certain types of paper and transparency film. For best results, adjust the paper settings each time you change paper types and paper sizes. For more information, see **choose the paper tray and set the paper type** on page 20.

paper	tips
HP papers	<ul style="list-style-type: none"> • HP Premium Inkjet Paper: Locate the gray arrow on the nonprinting side of the paper, and then insert paper with the arrow side facing up. • HP Premium or Premium Plus Photo Paper: Load the glossy (print) side down. Always load at least five sheets of regular paper in the main tray first, and then place the photo paper on top of the regular paper. • HP Premium Inkjet Transparency Film: Insert the film so that the white transparency strip (with arrows and the HP logo) is on top and is going into the tray first. • HP Iron-On T-shirt Transfers: Flatten the transfer sheet completely before using it; do not load curled sheets. (To prevent curling, keep transfer sheets sealed in the original package until you are ready to use them.) Manually feed one sheet at a time, with the unprinted side facing down (the blue stripe faces up). • HP Greeting Cards, Glossy Greeting Cards, or Textured Greeting Cards: Insert a small stack of HP greeting-card paper, with the print-side down into the main tray until it stops. • HP Restickable Inkjet Stickers: Place the sheets in the main tray, print-side (sticker-side) down.
Legal-size paper	Fully extend the paper-length guide and make sure that the main tray is pushed all the way in.
Postcards (only works with printing)	Insert a stack of postcards with the print-side down into the main tray until it stops. Line the postcards up on the right side of the main tray, slide the width guide up against the left side of the cards, and then slide the paper-length guide in until it stops.

paper	tips
Labels (works only with printing)	<ul style="list-style-type: none"> • Always use letter-size or A4-size label sheets designed for use with HP inkjet products (like Avery Inkjet Labels), and make sure that the labels are not over two years old. • Fan the stack of labels to make sure none of the pages are sticking together. • Place a stack of label sheets on top of standard paper in the main tray, print-side down. Do <i>not</i> insert labels one sheet at a time.
4" x 6" Photo paper (works only with printing)	<p>Insert the photo paper with the print-side down into the main tray until it stops. Place the long edge of the photo paper against the right side of the main tray, slide the paper-width guide up against the long edge of the photo paper, and slide the paper-length guide in until it stops. If the photo paper you are using has perforated tabs, load the photo paper so that the tabs are closest to you.</p>
Continuous (banner) paper (works only with printing)	<p>Continuous banner paper is also known as computer or z-fold paper.</p> <ul style="list-style-type: none"> • Before loading banner paper, remove all other paper from the main tray, then raise the output tray until it catches in the raised position. <div data-bbox="609 743 1057 1124" data-label="Image"> <p>The illustration shows a top-down view of the printer. The output tray is raised, and a sheet of paper is being fed into the main tray from the front. An arrow points to the paper's position in the tray.</p> </div> <p>Raise the output tray until it stays in the raised position.</p> <p>Insert first edge of paper into the main tray.</p> <ul style="list-style-type: none"> • If you use non-HP banner paper, use 20-lb. paper and fan the paper before loading it. • Verify that the stack of banner paper contains at least five pages in the stack. • Carefully tear off the perforated edge strips from both sides of the paper stack, if any, and unfold and refold the paper to make sure the pages do not stick together. • Put the paper in the main tray so that the unattached edge is at the top of the stack. Insert the first edge into the main tray until it stops, as shown in the illustration above.

choose the paper tray and set the paper type

If you want to use a different type of paper, such as photo paper, transparency film, banner paper, or envelopes, simply load that paper in the main tray. You should then change the paper type settings to ensure the best print quality.

If you have installed HP 250-sheet plain paper tray, that paper tray is the default paper tray that is used for copying. If you load a different type of paper in the main paper tray, you need to not only change the paper type settings, but also specify the paper tray to use.

Caution! You must also have the two-sided printing accessory installed to use the 250-sheet plain paper tray.

You can change copy settings from the front panel or from the HP Director. When you change settings using the front panel, the copy settings are reset two minutes after the unit completes the copy.

HP recommends paper type settings according to the type of paper you're using. For more information, see **recommended paper-type settings for copying** in the onscreen User's Guide.

- 1 Press **Tray Select/Paper Type**.
If you have both paper trays, press **Tray Select/Paper Type** until the desired paper tray is selected, indicated by the dot on the left.
- 2 When copying from the main tray, press  until the appropriate paper type appears.
- 3 Press **Enter** to choose the displayed paper type.

set the paper size

For more information, see **adjust paper settings for printing** in the onscreen User's Guide.

- 1 Press **Menu**.
- 2 Press **1**, then press **2**.
This selects **Copy Setup**, then selects **Paper Size**.
- 3 Press  until the desired size appears, then press **Enter** to select it.

learn more

See the load section in the onscreen User's Guide to learn more about the following:

- Recommended paper-type settings for printing
- Recommended paper-type settings for copying

use the scan features

4

Scanning is the process of converting text and pictures into an electronic format for your computer. You can scan just about anything:

- Text documents
- Photos
- Magazine articles
- 3D objects (be careful not to scratch the glass) to put into catalogs and flyers

Because the scanned image or text is in an electronic format, you can bring it into your word processor or graphics program and modify it to suit your needs. You can do the following:

- Scan text from an article into your word processor and quote it in a report, saving you a lot of retyping.
- Scan in a logo and use it in your publishing software, allowing you to print business cards and brochures for yourself.
- Scan in photos and e-mail them to coworkers and friends, create a photographic inventory of your office or home, or create an electronic scrapbook.

To use the scan features, your HP OfficeJet and computer must be connected and turned on. The HP OfficeJet software should also be installed on your computer prior to connecting the computer to the HP OfficeJet.

If your HP OfficeJet is connected to a network, you can scan to any of the computers that are on the network from the front panel or computer. The other computers on the network must also have the HP OfficeJet software installed.

scan an original

You can start a scan from your computer or from your HP OfficeJet.

to scan an original from your Windows computer



- 1 Load your original on the glass or in the automatic document feeder (ADF).
- 2 Press **Start Scan**.
A scan of the original appears in the HP Image Viewer.
- 3 In the HP Image Viewer, you can edit the scanned image. When you have finished, click **Accept**.
The HP OfficeJet does a final scan of the original and sends the image to the HP Photo View Center.
See the onscreen User's Guide for more information about using the HP Image Viewer.

to scan an original from your Macintosh computer

- 1 Load your original on the glass or in the automatic document feeder (ADF).
For more information, see **load originals** on page 13.
- 2 Press **Start Scan**.
A scan of the original appears in the HP Scan Window.
- 3 In the HP Scan Window, you can preview the image, change the image type, and select a different destination. Select a destination, then click **Send Now!**.
The HP OfficeJet does a final scan of the original and sends the image to the HP Workplace.
See the onscreen User's Guide for more information about using the HP Workplace.

scan to a different software program

If you prefer to scan your document to a software program other than the HP Photo View Center or HP Workplace, you can choose a different program from the Scan To list that appears in the front-panel display. The HP OfficeJet scans the document, launches the selected software program, and displays the scanned image in that program.

- 1 Load your original.
For more information, see **load originals** on page 13.
- 2 Press **Scan to** then press  to scroll through the **Scan To** list until the desired scan-to software program appears.
- 3 If you have more than one computer networked to the HP OfficeJet, you see a list of computers that have the HP OfficeJet software installed on them. Press  to scroll through the **Scan To** list until the desired scan-to software program appears.
- 4 Press **Start Scan** to begin the scan.
The HP OfficeJet scans your original and displays it in the selected software program.

stop scanning

You can stop a scan by pressing the **Cancel** button located on the front panel.

learn more

See the scanning section in the onscreen User's Guide to learn more about:

- Scanning text
- Scanning from a software program
- Editing scanned images
- Changing scan settings
- Change the scan-to settings for scanning text or images
- Scanning to a brochure or flyer

use the copy features

5

The copy features let you do the following:

- Produce high-quality color and black-and-white copies using a variety of paper types and sizes, including iron-on transfers.
- Reduce or enlarge the size of the copies you make from 25% to 400% of the copy's original size. (Percentages may vary between models.)
- Make the copy lighter or darker, adjust the color intensity, select the number of copies, and specify the quality of the copies you make.
- Use special copying features to create a poster, make many sizes of photos, make high-quality copies of photos using special photo paper, or to create transparencies.
- Make two-sided copies or copy from two-sided documents.

make copies

You can make copies using the front panel of your HP OfficeJet or by using the HP OfficeJet software on your computer. Many copy features are available using either method. However, you may find that the software offers easier access to special copy features.

All copy settings that you select on the front panel are reset **two minutes** after the HP OfficeJet completes the copy, unless you save the settings as the default settings. For more information, see **change settings for all copy jobs** in the onscreen User's Guide.

make a copy

- 1 Load your original on the glass or in the automatic document feeder (ADF).
- 2 Press **Start Copy, Black** or **Start Copy, Color**.

increase copy speed or quality

The HP OfficeJet provides three options that affect copy speed and quality.

- **Best** produces the highest quality for all paper and eliminates the banding (striping) effect that sometimes occurs in solid areas. **Best** copies more slowly than the other quality settings.
- **Normal** delivers high-quality output and is the recommended setting for most of your copying. **Normal** copies faster than **Best**.
- **Fast** copies faster than the **Normal** setting. The text is of comparable quality to the **Normal** setting, but the graphics may be of lower quality. Using **Fast** also cuts down on the frequency of replacing your ink cartridges, because it uses less ink.

- 1 Load your original on the glass or in the ADF.
- 2 Press **Quality** until the green light in front of the desired quality is lit.
- 3 Press **Start Copy, Black** or **Start Copy, Color**.

reduce or enlarge a copy

You can reduce or enlarge a copy of an original using either the **Reduce/Enlarge** button or the **Special Features** buttons. This section explains the **Reduce/Enlarge** features only.

For more information about Special Features options, see **perform special copy jobs** on page 28 for information about using **Fit to Page, Which Size?, Poster, 2 on 1, Margin Shift**, or **Mirror**.

- 1 Press **Reduce/Enlarge** to choose one of the following:
 - Custom 100% — lets you enter the percentage to reduce or enlarge your copy.
 - Full Page 91% — lets you reduce an original to 91% of its original size, which prevents cropping that may occur if you make a full-size (100%) copy.
 - Legal/Letter 72% — reduces an original to 72% of its original size, which lets you copy a legal-sized original to letter-sized paper.
- 2 If you are using the **Custom** option, press ◀ or ▶ to reduce or enlarge the copy.
You can also enter a number using the keypad.
- 3 Press **Start Copy, Black** or **Start Copy, Color**.



make copies lighter or darker

Use **Lighter/Darker** to adjust the lightness and darkness of the copies you make.

- 1 Press **Lighter/Darker**.
- 2 Press ◀ to lighten the copy or ▶ to darken it.
The circle moves to the left or right, depending on the button you press.
- 3 Press **Start Copy, Black** or **Start Copy, Color**.

change color intensity

You can adjust color intensity to make colors on your copy more vivid or more subtle.

- 1 Press **Menu**.
- 2 Press **1** and then press **3**.
This selects **Copy Setup**, and then selects **Color Intensity**.
- 3 Press  to make the image more pale or  to make the image more vivid.
The range of color intensity values appears as a circle on a scale on the front-panel display.
- 4 Press **Start Copy, Black** or **Start Copy, Color**.

enhance text sharpness and photo colors

Use **Text** enhancements to sharpen edges of black text. Use **Photo** for photographs or pictures to enhance light colors that may otherwise appear white.

Text enhancement is the default option. You can turn off **Text** enhancement by selecting **Photo** or **None** if the following occur:

- Stray dots of color surround some text on your copies.
- Large, black typefaces look splotchy (not smooth).
- Thin, colored objects or lines contain black sections.
- Horizontal grainy or white bands appear in light- to medium-gray areas.

- 1 Press **Menu**.
- 2 Press **1**, then press **1**.
This selects **Copy Setup**, and then selects **Enhancements**.
- 3 Press  until the desired enhancement (**Text**, **Photo**, **Text and Photo**, or **None**) appears.
- 4 Press **Start Copy, Black** or **Start Copy, Color**.

set the number of copies

You can set the number of copies using the front panel.

- 1 Press **Number of Copies**.
- 2 Press  until the desired number of copies appear, or use the keypad to enter the desired number of copies.
- 3 Press **Start Copy, Black** or **Start Copy, Color**.

change settings for all copy tasks

Save the copy settings you use most often by setting them as the default. This includes changes to Copy Setup options in the menu system, as well as other Copy area settings.

- 1 Make any desired changes to the Copy Setup options.
- 2 Make any desired changes to the button settings in the Copy Area.
- 3 Press **Menu**.

- 4 Press **1**, then press **4**.
This selects **Copy Setup**, and then selects **Set Copy Defaults**.
Your settings are saved.

perform special copy jobs

In addition to supporting standard copying, your HP OfficeJet can also do the following:

- **copy a photo**
- **fit a copy to the page**
- **print several copies on one page**
- **print two originals on one page**
- **shift image to increase the margin**
- **make two-sided copies**
- **make a poster**
- **prepare a color t-shirt transfer**

copy a photo

- 1 Load the photo on the glass.
- 2 If you are using photo paper, you must load it in the main paper tray. If you have the HP 250-sheet plain paper tray, do not load photo paper into that tray.
- 3 Press **TraySelect/Paper Type** until the **Upper Tray** is selected, as shown by the dot.
If you do not have the HP 250-sheet plain paper tray, the upper tray (main tray) is selected by default.
- 4 When **Upper Tray** is selected, press  until the desired photo paper option appears, then press **Enter** to select it.
For more information, see **recommended paper-type settings for copying** in the onscreen User's Guide.

Tip! To enlarge a photo automatically to a full page, press **Special Features** until **Fit to Page** appears, then press **Enter**.
For more information, see below.

- 5 Press **Menu**.
- 6 Press **1**, then press **1** again.
This selects **Copy Setup**, and then selects **Enhancements**.
- 7 Press  until **Photo** appears, then press **Enter** to select it.
- 8 Press **Start Copy, Black** or **Start Copy, Color**.

fit a copy to the page

Use **Fit to Page** when you want to automatically enlarge or reduce your original to fit the paper size you have loaded.

Tip! Make sure that the glass is clean and the original has been placed in the bottom-right corner of the glass. You cannot use the automatic document feeder (ADF) for this feature.

Original



Fit to Page

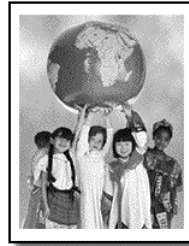

- 1 Load the original on the glass.
- 2 Load the appropriate paper.
- 3 Press **Special Features** until **Fit to Page** appears.
- 4 Press **Enter**.
- 5 Press **Start Copy, Black** or **Start Copy, Color**.

print several copies on one page

You can place multiple copies of an original on one page by selecting a photo size and then selecting the number of copies you want.

There are several common photo sizes available from the **Which Size?** option, which you access from the **Special Features** button. After you select one of the available sizes, you may be prompted to select the number of copies that can be placed on the page if there is room for more than one.

Original



Copy

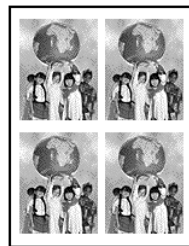

- 1 Load the original on the glass.
- 2 Load the appropriate paper in the main tray.
- 3 Press **Special Features** until **Which Size?** appears.
- 4 Press  until the desired photo size appears, then press **Enter**.

- 5 When **How Many?** appears, press  to select the number of images that will fit on a page.
Some larger sizes do not prompt you for a number of images.
- 6 Press **Enter** to select the number of photos you want to appear on a page.
- 7 Press **Start Copy, Black** or **Start Copy, Color**.

Tip! If the number of copies of the photo on a single page does not come out as expected, try turning the original on the glass 90 degrees and start the copy again.

print two originals on one page

You can print two different letter- or A4-sized originals on one page using the **2 on 1** feature. The copied images will appear side by side on the page in a landscape format. You can use the automatic document feeder (ADF) to load the originals or place them directly on the glass.

You cannot collate when making a 2 on 1 copy. Clipping may occur with legal-size originals.

This feature can be used with the Two-Sided Copy button to make 2 on 1, two-sided copies. See **make two-sided copies** on page 31.

Two Originals



Two originals on one page

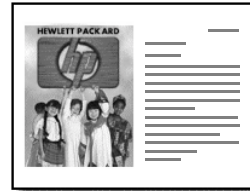

- 1 Place the first original on the glass. If you are using the ADF, load both originals there.
- 2 Press **Special Features** until **2 on 1 59%** appears, then press **Enter**.
- 3 Press **Start Copy, Black** or **Start Copy, Color**.
- 4 If you placed your first original on the glass you will be prompted to **Place 2nd original on glass**, then press **Enter**.

shift image to increase the margin

The MarginShift feature lets you shift the image to the left or right to increase the margin for binding. You can also adjust the reduction/enlargement percentage in this mode by entering a number on the numeric keypad.

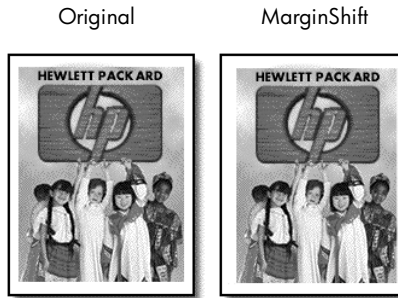

- 1 Load the original on the glass or in the ADF.
- 2 Press **Special Features** until **MarginShift 100%** appears.
- 3 Press ◀ or ▶ to shift the margin to the left or to the right. Each step is a ¼-inch (6.35 mm) shift.
- 4 If you wish to change the reduction/enlargement percentage as well, enter a number using the keypad, then press **Enter**.

Tip! If you do not wish to change the reduction/enlargement percentage, press **Enter** after you have selected the amount of MarginShift you want.

- 5 Press **Start Copy, Black** or **Start Copy, Color**.

make two-sided copies

The **Two-Sided Copy** button on the front panel lets you automatically make two-sided copies from single-sided or double-sided originals that are letter- or A4-sized.



You can make two-sided copies automatically only if your HP OfficeJet has an HP two-sided printing accessory. The two-sided printing accessory is standard equipment with some models or can be purchased separately.

- 1 Load your letter- or A4-sized originals in the ADF. You cannot make two-sided copies from legal-sized originals loaded in the automatic document feeder (ADF).
- 2 Press the **Two-Sided Copy** button.
- 3 Choose one of the following by pressing ▶ until the desired setting appears and then press **Enter**.
 - 1-sided original, 1-sided copy
This option produces a standard single-sided copy from a single-sided original.
 - 1-sided original, 2-sided copy

This option takes 2 single-sided originals and produces a two-sided copy.

- 2-sided original, 1-sided copy

This option produces single-sided copies of a two-sided original.

- 2-sided original, 2-sided copy

This option produces a two-sided copy from a two-sided original.

- 4 Press **Start Copy, Black** or **Start Copy, Color**.

make a poster

When you use the Poster feature you divide your original into sections, then enlarge the sections so you can assemble them into a poster.

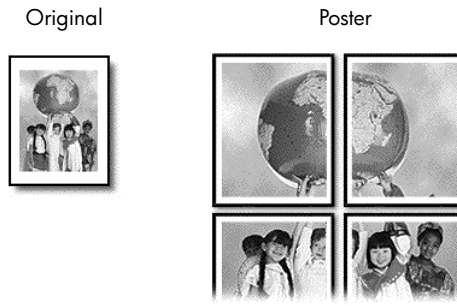

Tip! You can print a poster from a file on your computer. For more information, see **print a poster** in the onscreen User's Guide.

- 1 Load the original on the glass.

Tip! You cannot use the automatic document feeder (ADF) when making a poster.

- 2 Load the appropriate paper in the main tray.
- 3 Press **Special Features** until **Poster** appears.
The option **Poster 2 pages Wide** appears by default.
- 4 Press  to select how wide you want the poster to be.
- 5 Press **Enter** to confirm your selection.
- 6 Press **Start Copy, Black** or **Start Copy, Color**.

Tip! After you select the poster width, the HP OfficeJet adjusts the length automatically to maintain the proportions of the original. If the original cannot be enlarged to the selected poster size, an error message appears that tells you the number of pages wide that are possible. Select a smaller poster size and make the copy again.

prepare a color t-shirt transfer

Use the **Iron-On** feature to reverse text and images so that they appear backwards. After you iron a transfer onto a T-shirt, the picture appears properly on the shirt.



Tip! We recommend that you practice applying a T-shirt transfer on an old garment first.

- 1 Load the original on the glass or in the ADF.
- 2 Load the T-shirt transfer paper in the main tray.
- 3 Press **TraySelect/Paper Type** until the Upper Tray is selected.
- 4 Press **▶** until **Iron-On** appears and then press **Enter** to select it. Selecting this option automatically activates the **Mirror** function.
- 5 Press **Start Copy, Black** or **Start Copy, Color**.

stop copying

- ▶ To stop copying, press **Cancel** on the front panel.

learn more

See the copy section in the onscreen User's Guide to learn more about the following:

- Perform special copying
- Change color intensity
- Enhance text sharpness and photo colors
- Change settings for copying

copy setup menu options

The following options are available in the **Copy Setup** menu.

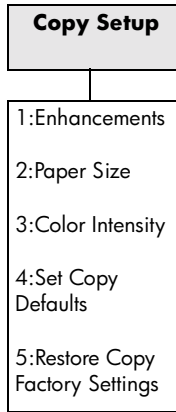

Press **Menu** to display the Copy Setup options.
Press ◀ and ▶ to move to the setting you want.
Press **Enter** to select the displayed setting.

maintain your hp officejet

6

This section provides instructions for keeping your HP OfficeJet in top working condition. Perform these maintenance procedures as necessary.

clean the glass

Dirty glass, from fingerprints, smudges, hair, and so on, slows down performance and affects the accuracy of special features such as Fit to Page and Copy.

- 1 Turn off the unit, unplug the power cord, and raise the lid.
- 2 Clean the glass with a soft cloth or sponge slightly moistened with a nonabrasive glass cleaner.

Caution! Do not use abrasives, acetone, benzene, or carbon tetrachloride on the glass; these can damage it. Do not place liquids directly on the glass. They may seep under it and damage the unit.

- 3 Dry the glass with a chamois or cellulose sponge to prevent spotting.

clean the lid backing

Minor debris can accumulate on the white document-backing located underneath the unit's lid.

- 1 Turn off the unit, unplug the power cord, and raise the lid.
- 2 Clean the white document-backing with a soft cloth or sponge slightly moistened with a mild soap and warm water.
- 3 Wash the backing gently to loosen debris; do not scrub the backing.
- 4 Dry the backing with a chamois or soft cloth.

Caution! Do not use paper-based wipes as these may scratch the backing.

- 5 If this does not clean the backing well enough, repeat the previous steps using isopropyl (rubbing) alcohol, and wipe the backing thoroughly with a damp cloth to remove any residual alcohol.

clean the exterior

Use a soft, damp, lint-free cloth to wipe dust, smudges, and stains off the case. The interior of the unit does not require cleaning. Keep fluids away from the interior of the unit as well as the front panel.

install the automatic document feeder tray

If you remove the automatic document feeder tray for any reason, you can replace it easily. Use the illustration below, and make sure the tray snaps into place.

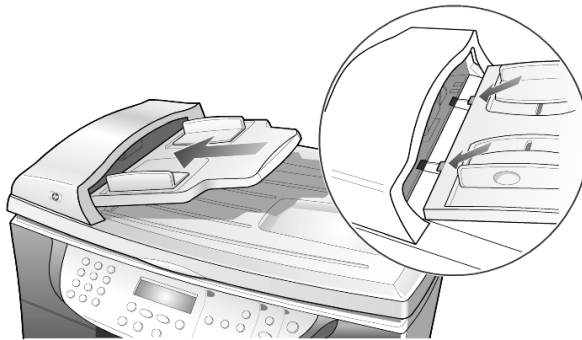

work with printheads and ink cartridges

As you discovered when you installed your HP OfficeJet, the ink delivery system consists of both ink cartridges, which contain the ink, and printheads, which control the print quality. To ensure the best print quality from your HP OfficeJet, you will need to perform some simple maintenance procedures, and when prompted by a front-panel message, replace the ink cartridges or printheads.

print a self-test report

If you are experiencing problems with printing, before cleaning or replacing the ink cartridges or printheads, you should print a self-test report. This report provides useful information about both your ink cartridges and your printheads, including status information, installation and expiration dates, and ink levels. It is useful to know the ink cartridge expiration dates, so you can purchase replacements before that date.

- 1 Press **Menu**.
- 2 Press **2**, and then press **2**.

This selects the **Print Report** menu, then selects **Self-Test Report**.

A self-test report is printed for your HP OfficeJet, which may indicate the source of any problems you may be having. For example, you may notice that one color does not print evenly across the page, which may indicate a problem with the corresponding printhead.

check the ink level

An easy way to check the ink supply level can be done from the front panel.

- 1 Press **Menu**.
- 2 Press **3**, then press **1**.
This selects the **Status and Maintenance** menu, then selects the **Check Ink Level** option.
A message in the front-panel display lets you know how much ink you have left, for both black and tri-color ink cartridges.
- 3 Press **Cancel** to exit the menu.

perform color calibration

The **Color Calibration** option prints out a report that lets you manually improve your color printing or copying. You should perform this procedure only if you see problems with color tints, such as noticeably incorrect flesh tones.

- 1 Press **Menu**.
- 2 Press **3**, then press **4**.
This selects the **Status and Maintenance** menu, then selects the **Perform Color Calibration** option.
A Color Calibration report is printed.
- 3 Follow the instructions on the report to determine the correct Color Patch Number.
- 4 At the prompt on the front-panel display, enter the Color Patch Number, then press **Enter**.

handle printheads

Before you replace or clean a printhead, you should know the part names and how to handle the printhead.

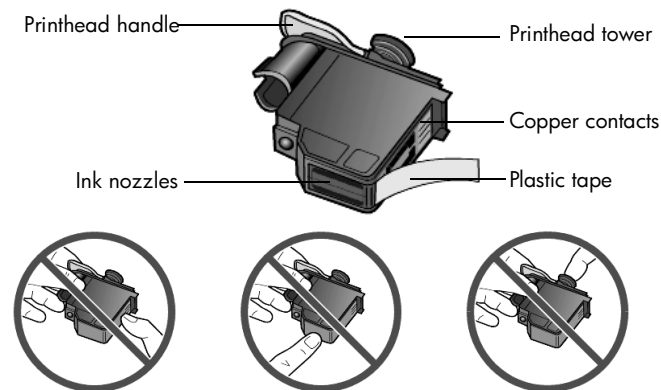

Do not touch the copper contacts, the ink nozzles, or the printhead tower.

**verify a
printhead needs
to be replaced**

If a printhead error message appears on the front-panel display, verify that the printhead needs to be replaced.

- 1 Turn the unit off and then turn it on.
If the error message still appears, continue with the following steps.
- 2 Open the print-carriage access door by lifting the handle until the door locks into place.
The print carriage moves to the center of the unit.

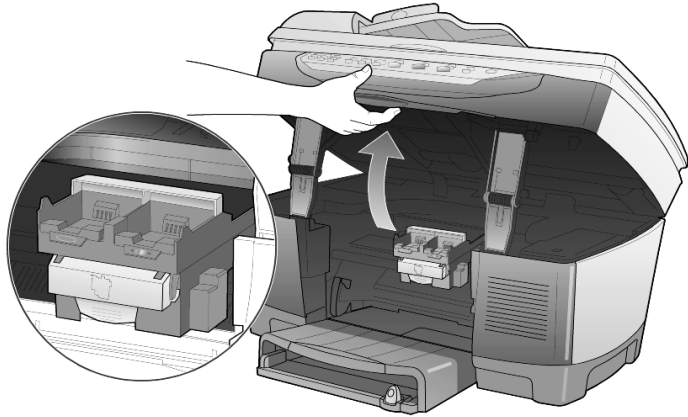

- 3 After the print carriage stops moving, release the gray print carriage latch and then lift the print carriage to access the printheads.

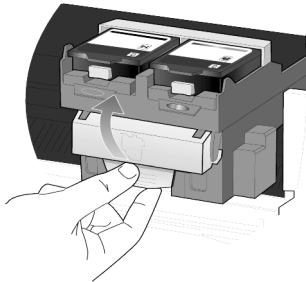

- 4 Remove the old printhead by lifting the printhead handle and pulling upward.

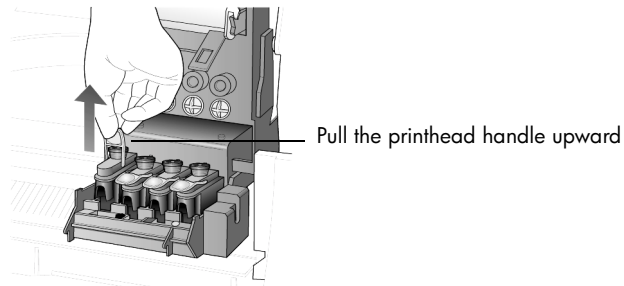

- 5 If there is plastic tape on the failed printhead, remove the plastic tape.
- 6 Push the failed printhead firmly down into the appropriate slot using the printhead handle. Do not touch the printhead tower, and do not remove the printhead handle.

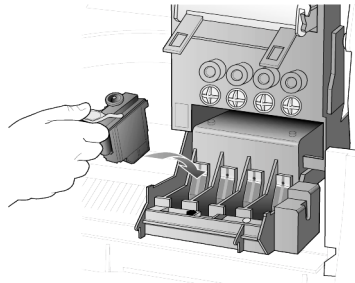

- 7 Move the print carriage latch down, and make sure the loops catch the hooks. Snap the latch into place, then close the print carriage access door.
- 8 If the error message still appears, remove and reinsert the printhead again and close the print carriage access drawer.
- 9 If the error message still appears, replace the printhead as described in the following section.

replace the printheads

If you experience print quality issues that cannot be resolved by cleaning your printheads and you have verified that the printheads need to be replaced, you may need to replace them. You may also see front-panel display messages that indicate when individual printheads need to be replaced.

See the *Support and Specifications* booklet for information on ordering replacement printheads.

- 1 Turn on the unit, then open the print-carriage access door by lifting the handle until the door locks into place.
The print carriage moves to the center of the unit.

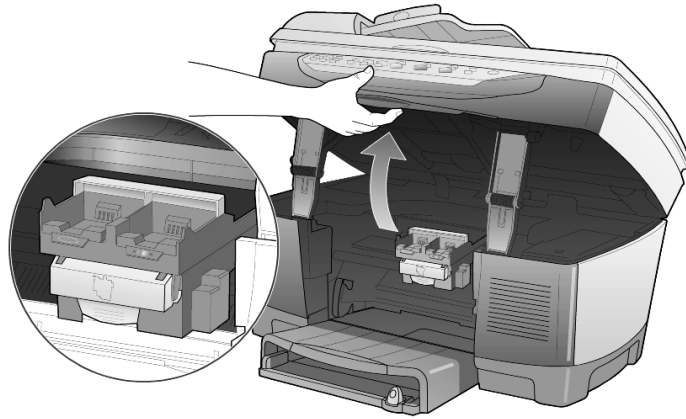

- 2 After the print carriage stops moving, release the gray print carriage latch and then lift the print carriage to access the printheads.

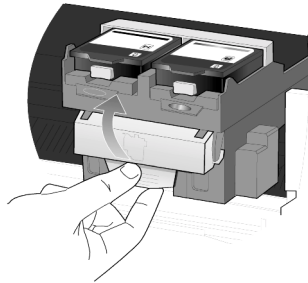

Caution! To avoid damaging the printer, remove a printhead only when a replacement is available. If a printhead is removed without being replaced:

- Close the print carriage and the print-carriage access door.
 - Replace the printhead within 24 hours.
 - Never remove an ink cartridge and a printhead at the same time.
- 3 Remove the old printhead by lifting the printhead handle and pulling upward.

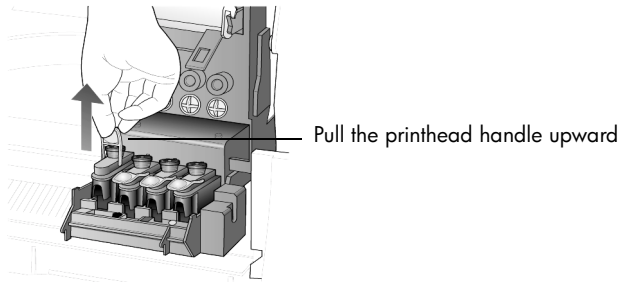

- 4 Remove the new printhead from its packaging and, being careful to touch only the black plastic, gently remove the plastic tape.

Caution! Do not touch the copper contacts, the printhead tower, or the ink nozzles.

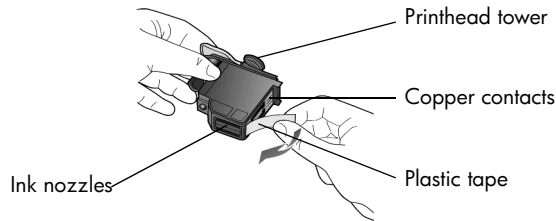

removing the plastic tape from the printhead

- 5 Match the color on the top of the printhead to the color on the printhead carriage.
- 6 Push the new printhead firmly down into the appropriate slot using the printhead handle. Do not touch the printhead tower, and do not remove the printhead handle.

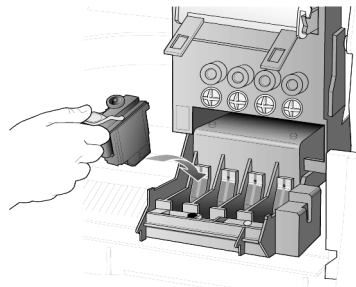

- 7 Move the print carriage latch down, and make sure the loops catch the hooks. Snap the latch into place, then close the print carriage access door.
- 8 After the message appears in the front-panel display, press **Enter** to align the printheads.

A page prints to confirm alignment. You can discard or recycle this page. If the page does not appear, see the Troubleshooting help, which you access from the HP Director.

handle ink cartridges

Before you replace or clean an ink cartridge, you should know the part names and how to handle them.

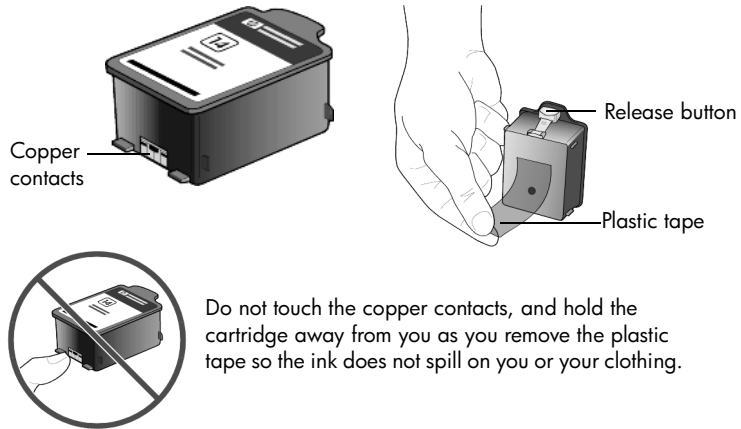

replace the ink cartridges

Front-panel display messages appear under the following conditions to let you know that you should replace your ink cartridges.

- Low ink levels
- Ink cartridges are approaching their expiration dates

Caution! If you ignore the messages and do not replace the ink cartridges, eventually the HP OfficeJet will stop working completely to avoid damaging the printheads.

See the *Support and Specifications* booklet for information on ordering replacement ink cartridges.

- 1 Turn on the unit, then open the print-carriage access door by lifting the handle until the door locks into place.
The print carriage moves to the center of the unit.

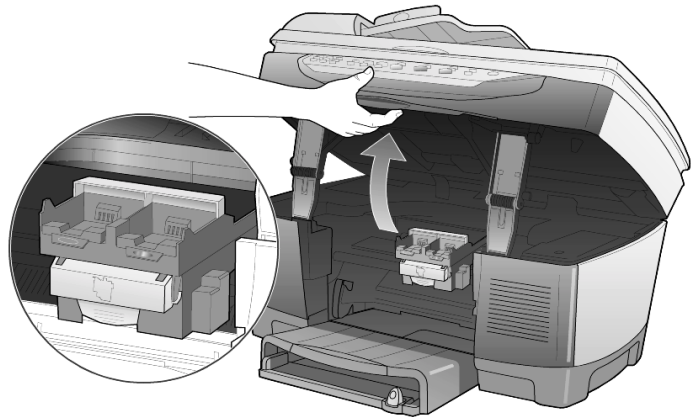

- 2 After the carriage stops moving, press the gray button to release the ink cartridge, then pull it up and out of its slot.

Caution! To avoid damaging the printer, remove an ink cartridge only when a replacement is available. If an ink cartridge is removed without being replaced:

- Close the print carriage and the print-carriage access door.
- Replace the ink cartridge within 24 hours.
- Never remove an ink cartridge and a printhead at the same time.

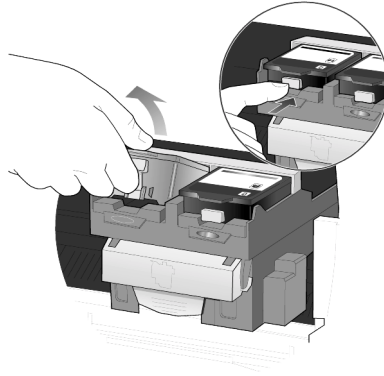

- 3 Remove the new ink cartridge from its packaging and, being careful to touch only the black plastic, gently remove the plastic tape.

Caution! Hold the cartridge away from you as you remove the plastic tape so the ink does not spill on you or your clothing.

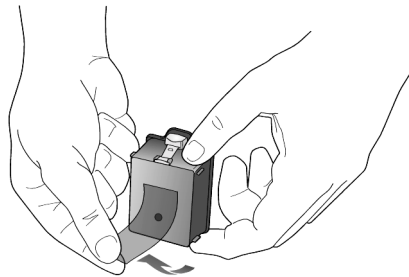

Caution! Do not touch the copper contacts.

- 4 Push the new ink cartridge firmly down into the appropriate slot until it clicks into place.

Note the color bars on the print carriage.

The ink-cartridge label should be face-up after the cartridge is inserted.

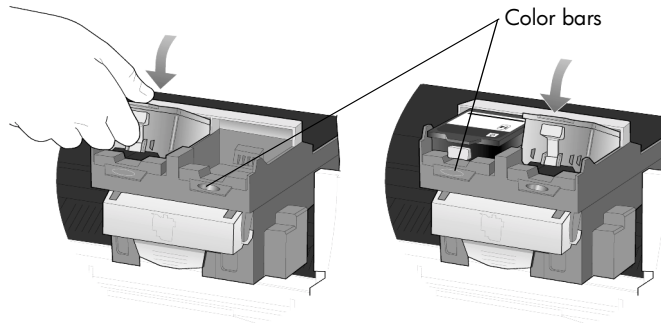

place the ink cartridges into their respective slots on the left and right

- 5 Close the print-carriage access door.

align the printheads

The HP OfficeJet prompts you to align the printheads every time you install or replace a printhead or ink cartridge. Aligning the printheads ensures high-quality output.

To align the printheads after the message appears on the display, press **Enter** on the front panel.

To align the printheads at any other time do the following:

- 1 Press **Menu**.
- 2 Press **3**, then press **3**.

This selects the **Status and Maintenance** menu, then selects the **Align PrintHeads** option.

A page prints to confirm printhead alignment. You can either discard or recycle this page. If the page does not appear, see the Troubleshooting help, which you access from the HP Director.

clean the printheads

Use this feature when the Self-Test Report shows streaking or white lines through any of the colored bars. Do not clean printheads unnecessarily. This wastes ink and shortens the life of your printheads.

- 1 Press **Menu**.
- 2 Press **3**, then press **2**.

This selects the **Status and Maintenance** menu, then selects the **Clean PrintHeads** option.

If copy or print quality still seem poor after you clean the printheads, replace the printhead that is affected.

clean the ink cartridge contacts

Clean the ink cartridge contacts only if you get repeated front panel messages prompting you to check a cartridge after you already have.

Caution! Do not remove both ink cartridges at the same time. Remove and clean them one at a time.

Make sure you have the following materials available:

- A clean, lint-free cloth
- Distilled, filtered, or bottled water (do not use tap water, as it may contain contaminants that can damage the printheads)

Caution! Be careful not to get ink on your hands or clothing.

- 1 Turn the unit on and open the print-carriage access door. The print carriage moves to the center.
- 2 After the print carriage has moved to the center, unplug the power cord from the back of the unit.



Warning! It is very important that you disconnect the printer from its electrical power source before touching the ink cartridge contacts. Electrical shock or severe damage to the printer can occur if you touch the contacts while there is electrical power to the printer. Do not use the **On** button to turn the printer off.

- 3 Press the gray button to release the ink cartridge, then pull it up and out of its slot.
- 4 Inspect the ink cartridge contacts and the contacts inside the ink cartridge socket for ink and debris buildup.
- 5 Clean any visible ink deposits with a clean, soft, lint-free cloth. If necessary, moisten the cloth with one drop of water.

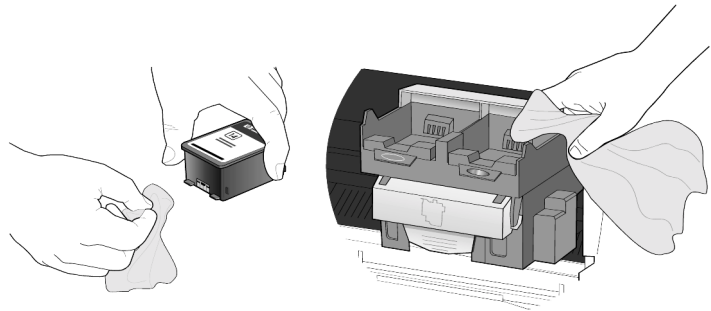

- 6 Place the ink cartridge back into the holder.
- 7 Repeat if necessary for the other ink cartridge.
- 8 Close the door and plug in the unit. Because you removed an ink cartridge from its holder, the HP OfficeJet needs to align the printheads.
- 9 After the message appears in the front-panel display, press **Enter** to align the printheads. A page is printed to confirm alignment.

clean the printhead contacts

Clean the printhead copper contacts only if you get repeated front panel messages prompting you to check a printhead after you already have.

Caution! Do not remove all printheads at the same time. Remove and clean them one at a time.

Make sure you have the following materials available:

- A clean, lint-free cloth
- Distilled, filtered, or bottled water (do not use tap water, as it may contain contaminants that can damage the printheads).

Caution! Be careful not to get ink on your hands or clothing.

- 1 Turn the unit on and open the print-carriage access door. The print carriage moves to the center.
- 2 After the print carriage has moved to the center, unplug the power cord from the back of the unit.



Warning! It is very important that you disconnect the printer from its electrical power source before touching the printhead contacts. Electrical shock or severe damage to the printer can occur if you touch the contacts while there is electrical power to the printer. Do not use the **On** button to turn the printer off.

- 3 Release the gray print carriage latch and then lift the print carriage to access the printheads.
- 4 Remove the printhead by lifting the printhead handle and pulling upward.
- 5 Inspect the copper contacts and the contacts inside the printhead socket for ink and debris buildup.
- 6 Clean any visible ink deposits with the clean, soft, lint-free cloth. If necessary, moisten the cloth with one drop of water.

Caution! Clean only the copper contacts in the front of the printhead, and wipe upwards only. Do not clean the ink nozzles on the under side of the printhead. They can become damaged or clogged by this type of cleaning.

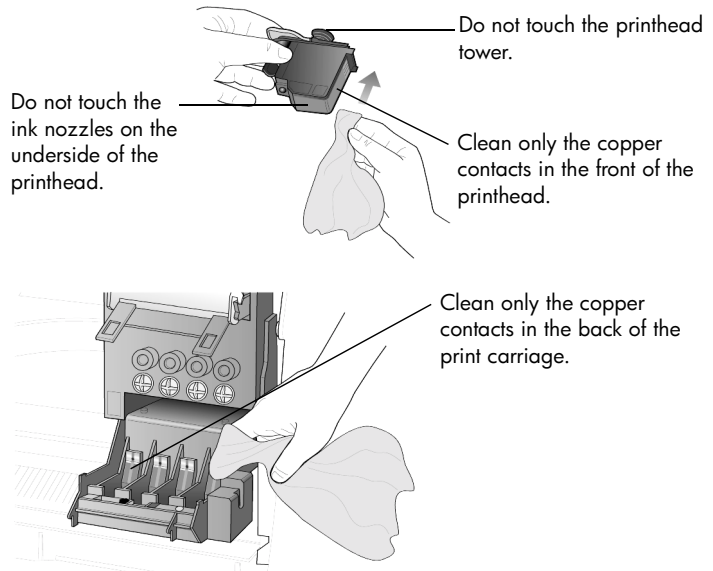

- 7 Place the printhead back into the holder.
- 8 Repeat cleaning of other printheads, if necessary.
- 9 Move the print carriage latch down, and make sure the loops catch the hooks. Snap the latch into place, then close the print-carriage access door.
- 10 Close the door and plug in the unit.
After cleaning the contacts, you should align the printheads.
- 11 Press **Menu**.
- 12 Press **3**, then press **3**.
This selects the **Status and Maintenance** menu, then selects the **Align PrintHeads** option.
A page prints to confirm printhead alignment. You can either discard or recycle this page. If the page does not appear, see the Troubleshooting help, which you access from the HP Director.

replacement alternatives

To get the best performance from your HP OfficeJet, we recommend using only genuine Hewlett-Packard supplies. See the Support and Specifications booklet for information on ordering replacement ink cartridges and printheads.

Caution! Damage that results from modifying or refilling HP ink cartridges or the use of non-HP ink is specifically excluded from the warranty coverage for the printer and printer supplies.

non-hp ink cartridges

The Ink Level Gauge may not work properly with a non-HP ink cartridge. If you choose to print with a non-HP ink cartridge, you may not know when the cartridge is running low or empty. Printing with an empty ink cartridge may seriously damage the printheads.

Any damage resulting from the use of a non-HP ink cartridge is not the responsibility of Hewlett-Packard.

refilled ink cartridges

To install a refilled HP ink cartridge, you must override the Ink Level Gauge.

override the ink level gauge

Overriding the Ink Level Gauge disables the printer's ink level tracking feature, but allows you to use a refilled cartridge.

Caution! If you use the override sequence described below, you will disable the Ink Level Gauge for your ink cartridge. If you choose to continue printing with an ink cartridge that has had its Ink Level Gauge disabled, you will not know when the cartridge is running low or empty. Printing with an empty cartridge may seriously damage your printheads. Damage that results from continued use of an ink cartridge with a disabled Ink Level Gauge is not the responsibility of Hewlett-Packard. Damage that results from the use of non-HP ink is not the responsibility of Hewlett-Packard.

The Ink Level Gauge is automatically reset when a different ink cartridge is installed in the printer.

Overriding the Ink Level Gauge does not affect ink cartridge expiration dates. The printer cannot use an expired ink cartridge.

Follow these steps to override the Ink Level Gauge:

to override the ink level gauge for the black ink cartridge

- 1 Press ◀ and ▶ at the same time, then release.
- 2 On the keypad, press in order, **7, 8, 9**.
- 3 When the prompt appears asking if you want to override the ink level gauge, press **1** for **Yes**, or **2** for **No**.

to override the ink level gauge for the tri-color ink cartridge

- 1 Press ◀ and ▶ at the same time, then release.
- 2 On the keypad, press in order, **4, 5, 6**.
- 3 When the prompt appears asking if you want to override the ink level gauge, press **1** for **Yes**, or **2** for **No**.

Always install an ink cartridge before performing an Ink Level Gauge override.

restore factory defaults

You can restore the original factory settings to what they were when you purchased your HP OfficeJet. Choosing to restore your factory defaults restores all settings, except copy settings and date information.

You can perform this process from the front panel only.

- 1 Press **Menu**.
- 2 Press **3**, then press **5**.
This selects the **Status and Maintenance** menu, then selects the **Restore Factory Defaults** option.
The factory default settings are restored.

set the language or country/region

Usually, the language and country or region are set when you install the HP OfficeJet. If you need to reset either the country, region, or language, use the following procedure.

Tip! If you accidentally choose the wrong language and are unable to read the front-panel display, simply follow the first 3 steps using the keypad to choose the correct language. You may also consider printing a Self-Test report to identify the country and language that have been selected.

- 1 Press **Menu**.
- 2 Press **3**, then press **7**, then press **Enter**.
This selects the **Status and Maintenance** menu, then selects the **Set Country and Language** option.
- 3 To select the language, you can do the following:
 - Press  until the desired language appears.
 - Wait until the desired language appears on the front panel display.
- 4 Enter the two-digit number corresponding to the language on the keypad.
For example: for English, you would enter 11.
- 5 After entering the language, you are prompted to confirm that the language you selected is the one you want.
- 6 Press **1** for **Yes** and **2** for **No**.
- 7 After the language is selected, you are prompted with all the countries or regions for that selected language.

- 8 To select the country or region, you can:
 - Press  until the desired country or region appears.
 - Wait until the desired country or region appears on the front panel display.
- 9 Enter the two-digit number corresponding to the country/region on the keypad.
For example: for USA, you would enter 10.
- 10 After entering the country, you are prompted to confirm that the country or region you selected is the one you want.
- 11 Press **1** for **Yes** or **2** for **No**.
You can confirm the country/region and language by printing a Self-Test Report.
- 12 Press **Menu**, press **2**, and then press **2** to print the Self-Test report.

set the power save mode time

The bulb in your HP OfficeJet remains on for a specified period so that the unit is immediately ready to respond to your request. When the HP OfficeJet has not been used within that specified period, it turns the bulb off to preserve power and displays **Power Save On** in the front-panel display. (You can exit this mode by pressing any button on the front panel.)

Your unit is automatically set to enter power-save mode after 12 hours. Follow these steps if you want the HP OfficeJet to enter this mode earlier.

- 1 Press **Menu**.
- 2 Press **3**, then press **6**.
This selects the **Status and Maintenance** menu, then selects the **Set Power Save Mode Time** option.
- 3 Press  until the desired time appears, then press **Enter**.

maintenance menu options

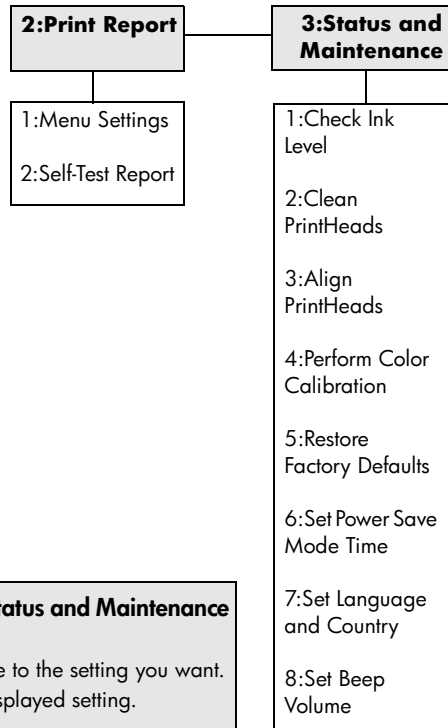

Use **Menu** to display the **Status and Maintenance** menu options.

Press **◀** and **▶** to move to the setting you want.
Press **Enter** to select the displayed setting.

additional setup information

7

This section covers how to handle messages that may or may not appear during installation, how to set up the connection between your computer and your HP OfficeJet, and how to add and remove the HP OfficeJet software. The standard installation instructions are provided in your Setup Poster, which you should keep for later use.

For comprehensive information, see the fully-searchable onscreen User's Guide, which is accessible only if the software has been installed. To access the guide for **Windows**, go to the **Director**, click **Help**, and then choose **User's Guide**.

To access the guide for **Macintosh**, go to the **Director**, click **Tools**, and then choose **View Onscreen Guide**.

possible installation problems

If you follow the instructions in the Setup Poster correctly, you should not have any problems with the installation of your HP OfficeJet. If you do not follow the instructions, you may see any of the following problems:

If Microsoft's New Hardware Found message does not appear

If you installed the HP OfficeJet software first as requested on the Setup Poster, and you are a Windows 98/2000/ME/XP user, a series of Microsoft New Hardware Found messages should have appeared on your screen during software installation.

If the Microsoft messages did not appear, try the following:

- Verify that you are using a high-speed (12 Mbps) USB cable and that it does not exceed five meters in length (16.4 feet).
- Verify that the computer is USB-ready. For more information about determining whether your computer is USB-ready, see your computer's documentation or check with the computer's manufacturer.
- Verify that the cable is plugged fully into your HP OfficeJet and directly connected to the USB port on your computer. After the cable is connected properly, turn your HP OfficeJet off and then on again.
- Turn your HP OfficeJet off and then on again, then restart your computer.
- If the previous steps do not solve the problem, remove and reinstall the software. For more information, see **remove and reinstall your hp officejet software** on page 57.

If the New Hardware Message appears (Windows 98, 2000, XP, or ME)

If you set up your HP OfficeJet and connect it directly to your computer *before* you install the software, you may encounter one of the following messages:

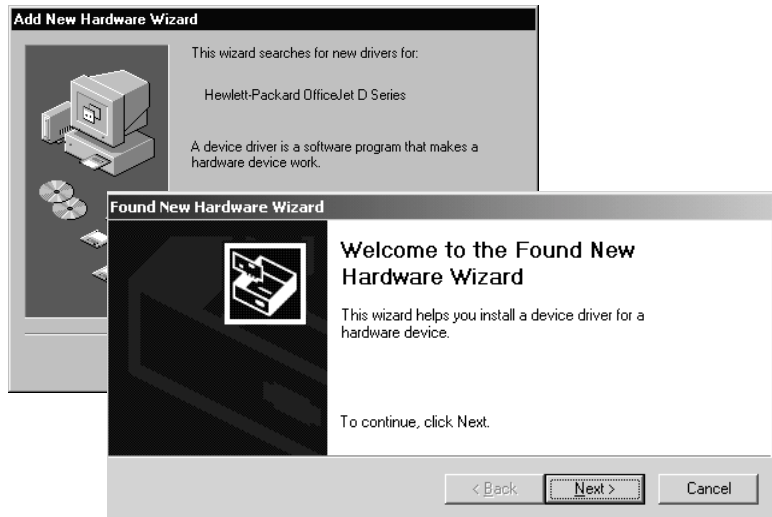

To avoid errors, install the HP OfficeJet software before you connect the HP OfficeJet to your computer. If one of the above messages appeared *and* you clicked **Next** or **OK**, do the following:

- 1 Press **Esc** to exit.
- 2 Turn off your HP OfficeJet.

- 3 Follow the software installation steps outlined in the Setup Poster that came with your HP OfficeJet.

If the previous version installed message appears

If you receive a message that you have a previously installed version, you will not be able to finish installing the HP OfficeJet software.

You will have to uninstall the previously installed version in order to install the HP OfficeJet software.

If your computer is unable to communicate with your HP OfficeJet

If communication cannot be established between your computer and HP OfficeJet (for example, the HP OfficeJet status icon has the yellow error triangle), try the same tasks outlined under **If Microsoft's New Hardware Found message does not appear** on page 53.

connect your hp officejet to your computer

Your HP OfficeJet supports HOT Swapping, meaning you can connect to the HP OfficeJet while the power is on at your computer and on the HP OfficeJet.

This section covers the following topics:

- **connect your parallel cable adapter**
- **setup for simple sharing**
- **connect your usb port**

For more information about networking options and installation and configuration issues, see the parallel cable adapter flyer or the HP JetDirect 200m print server connector booklet.

connect your parallel cable adapter

Your HP OfficeJet can be connected to your computer with your parallel printing cable and the parallel cable adapter.

Simply attach your parallel printing cable to the parallel cable adapter and plug the parallel cable adapter into the port on the back of your HP OfficeJet. The parallel cable adapter should click into place when correctly attached.

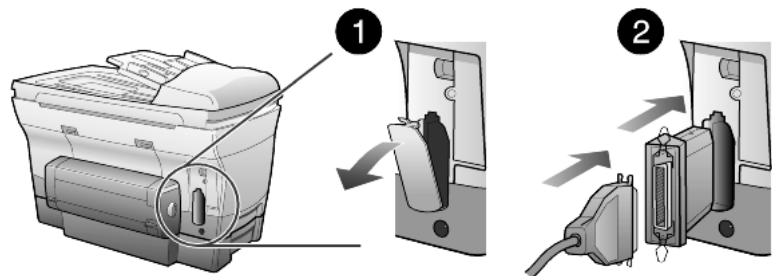



Should you need to disconnect your parallel adapter from the HP OfficeJet, press the buttons found on the top and bottom of the adapter and pull the adapter straight out. You may need to disconnect the power cord to access the lower button on the adapter.

setup for simple sharing

Your HP OfficeJet can be shared by two different computers by having both computers connected directly to the HP OfficeJet. Both computers must have the HP OfficeJet software installed. The list below shows the supported combinations of communication between the HP OfficeJet and your computers.

The following communication configurations can be used with your HP OfficeJet:

- HP JetDirect 200m print server connector (network) and USB (Windows and Macintosh)
- Parallel cable adapter (parallel) and USB (Windows only)



Simple Sharing is supported by connecting to the HP OfficeJet in one of the following configurations: HP OfficeJet to two Windows computers or HP OfficeJet to two Macintoshes. You cannot mix platforms, that is, you cannot connect the HP OfficeJet to both a Windows computer and a Macintosh.



There can be up to 10 client computers on the network portion of the 200m print server connector and USB combination.

connect your usb port

Connecting to your HP OfficeJet with USB is straightforward. Simply plug one end of the USB cable into the back of your computer and the other in the back of the HP OfficeJet.

what works	what does not work
Plugging into the USB port on your computer	Plugging into the USB port located on the keyboard
Plugging into a powered hub that is connected to the USB port on your computer	Plugging into a non-powered USB hub



AppleTalk is not supported.

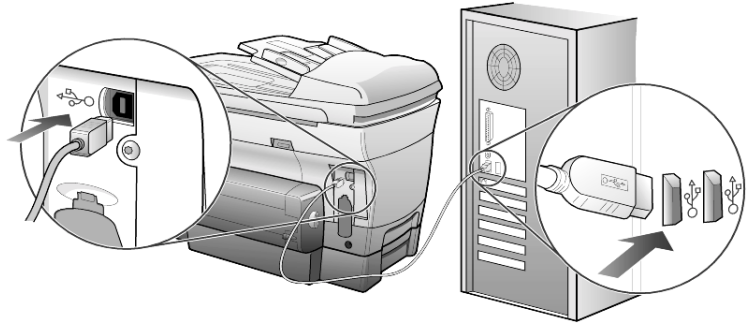

connecting to the USB port on your computer

remove and reinstall your hp officejet software

Do *not* simply delete the HP OfficeJet program files from your hard drive. Be sure to remove them properly using the uninstall utility provided in the HP OfficeJet program group.

to uninstall from a Windows computer

- 1 On the Windows taskbar, click **Start**, choose **Programs** or **All Programs** (XP), choose **Hewlett-Packard**, choose **HP OfficeJet D Series**, then choose **HP Uninstaller** or **Uninstall Software**.
- 2 Follow the directions on the screen.
- 3 If you are asked whether you would like to remove shared files, click **No**.
Other programs that use these files may not work properly if the files are deleted.
- 4 After the program finishes removing the software, disconnect your HP OfficeJet, and restart your computer.
- 5 To reinstall the software, insert the HP OfficeJet D Series CD-ROM into your computer's CD-ROM drive, and follow the instructions that appear.

to uninstall from a Macintosh computer

- 1 Double-click on **Applications:HP All-in-One Software** folder.
- 2 Double-click on **Uninstaller**.
- 3 Follow the directions that appear on the screen.

learn more

See the additional setup information section in the onscreen User's Guide to learn more about:

- Set up your HP OfficeJet for network printing
- Understand point-and-print and peer-to-peer networks
- Set up the host
- Set up a point-and-print client
- Set up a peer-to-peer client (Windows 98 server to 2000 client)

index

Numerics

2 on 1 feature **30**

250-sheet plain paper tray **8, 15, 17, 20**

A

adjust settings

copy **27**

align printheads **44**

automatic document feeder

copy from **6**

load originals in **14**

use for two-sided copies **31**

B

banner paper, tips on loading **19**

best copy quality **26**

buttons

cancel **8**

front panel **4**

keypad **8**

lighter/darker **8, 26**

menu **7, 8**

number of copies **8, 27**

quality **9, 26**

reduce/enlarge **8, 26**

scan to **9, 22**

special features **8, 30, 32**

start scan **9, 21**

tray select/paper type **8, 33**

two-sided copy **31**

C

cancel

button **8**

copy **33**

scan **23**

cartridge

check ink level **37**

clean contacts **44**

replace ink cartridges **42**

change paper tray **20**

clean

ink cartridge contacts **44**

printhead contacts **46**

printheads **44**

the exterior **36**

the glass **35**

the lid backing **35**

color

improve printing **37**

intensity of copy **27**

connect your parallel cable adapter **55**

continuous paper, tips on loading **19**

contrast, enhance photo colors **27**

copy

2 on 1 **30**

an original **29**

buttons **4**

change default settings **27**

color intensity **27**

darken **8, 26**

defaults **27**

enhancements **27**

enlarge **26**

fit to page **28**

from ADF **6**

lighten **8, 26**

make a poster **32**

make copies **5, 25**

photo **28**

quality **9, 26**

reduce **26**

set number of copies **5, 27**

- several copies on a page **29**
- special copy jobs **28**
- speed **26**
- stop **33**
- T-shirt transfer **33**
- two-sided copies **8, 31**

country setup **49**

D

- darken a copy **26**
- default settings
 - change for copy **27**
 - restore factory defaults **49**
- director review **9**
- double-sided copies **31**

E

- enhancements **27**
- enlarge a copy **8, 26, 28**
- envelopes, load **17**

F

- factory defaults
 - change for copying **27**
 - restore **49**
- fast copy quality **26**
- fit to page **28**
- front panel
 - features **4**
 - overview **7**
 - scan from **21**
 - tutorial **3**
- front-panel display **4**
 - set language **49**

G

- glass cleaning **35**
- greeting cards, load **18**

H

- help **1**
- hp director **9–11**
- hp officejet
 - menu functions **12**
 - simple sharing **56**
 - software **9**
- hp papers, tips on loading **18**
- hp two-sided printing accessory **31**

I

- image, shift **30**
- ink cartridges
 - check ink level **37**
 - clean **44**
 - refill **48**
 - replace **42**
- ink level
 - check **37**
 - low **42**
 - override gauge **48**
- inkjet paper, load **18**
- intensity of color copy **27**
- introduction to the Director **9**
- iron-on **33**

K

- keypad **8**

L

- labels, load **19**
- lamp power save mode **50**
- language setup **49**
- legal-size paper
 - copy from **26**
 - tips on loading **18**
- lid backing, clean **35**
- light power save mode **50**
- lighten or darken copies **8, 26**
- load
 - 250-sheet plain paper tray **15**
 - change the paper type **20**
 - envelopes **17**
 - ink cartridges **42**
 - multiple originals **6**
 - original in the ADF **6, 14**
 - original on the glass **13**
 - paper **15**
 - photo paper **19**
 - postcards **18**
 - printheads **39**
 - set the paper size **20**
 - tips **18**
- lower paper tray, see 250-sheet plain paper tray

M

- main paper tray, load **15**
- maintenance
 - align printheads **44**

- check ink level **7**
- clean the exterior **36**
- clean the glass **35**
- clean the lid backing **35**
- clean the printheads **44**
- power save mode time **50**
- printhead replacement verification **38**
- replace ink cartridges **42**
- replace printheads **39**
- restore factory defaults **49**
- self-test report **36**
- margins, increase **30**
- menus
 - copy setup **34**
 - print reports **51**
 - status and maintenance **51**

N

- normal copy quality **26**
- number of copies **8**
 - set **5, 27**

O

- originals
 - how to place in the ADF **14**
 - how to place on glass **13**
 - multiple copies **29**
 - print two on one page **30**
- output tray **19**
 - extender **16**

P

- paper
 - change default size for copy **20**
 - change the type **20**
 - load **15**
 - recommended **14, 15**
 - set the size **20**
 - tips on loading **18–19**
- paper size, change for copy **20**
- paper tray
 - select **8**
 - set **20**
- parallel cable adapter **55**
- photo mode enhancement **28**
- photo paper, load **19**
- photo view center **22**
- photos
 - copy **28**
 - enhance copy **27**

- postcards, load **18**
- poster, copy to **32**
- power save mode setup **50**
- power save mode time **50**
- print
 - color calibration report **37**
 - continuous (banner) paper, tips on loading **19**
 - envelopes **17**
 - self-test report **36**
- print cartridges, see ink cartridges
- printheads
 - align **44**
 - clean **44, 46**
 - load **39**
 - replace **39**
 - replacement verification **38**

Q

- quality **26**
- quick start **3**
 - review the director **9**
 - use with a computer **9**

R

- reduce a copy **5, 8, 26, 28**
- reinstall software **57**
- remove software **57**
- reports
 - color calibration **37**
 - self-test **36**
- restore factory settings **49**

S

- save
 - a scanned image **21**
- scan
 - buttons **4**
 - different destination **22**
 - from front panel **21**
 - stop **23**
- self-test report **36**
- set
 - country and language **49**
 - number of copies **27**
 - power save mode **50**
- settings
 - best copy quality **26**
 - copy a photo **28**
 - copy color intensity **27**
 - copy defaults **27**

- copy quality **26**
- copy speed **26**
- country and language **49**
- darken a copy **26**
- enlarge a copy **26**
- fast copy quality **26**
- lighten a copy **26**
- normal copy quality **26**
- paper tray **20**
- power save mode **50**
- reduce a copy **26**
- save copy **27**
- text enhancement **27**
- setup
 - additional information **53**
 - simple sharing **56**
- shift margins **30**
- software
 - introduction **9**
 - remove and reinstall **57**
 - special features **8, 30, 32**
 - limitations **13**
- stickers, load **18**

- stop
 - copy **33**
 - scan **23**
- supply, check ink level **37**

T

- text
 - enhance **27**
- transparency film
 - recommend choices **15**
 - tips on loading **18**
- troubleshooting
 - remove and reinstall software **57**
- T-shirt transfer **33**
 - load **18**
- tutorial **3**
 - before you begin **3**
 - front panel features **4**
 - make a copy **5**
- two-sided copies **8, 31**

U

- USB cable installation **56**

Visit the hp officejet information center

It has everything you need to get the most value from your HP OfficeJet.

- Technical Support
- Supplies and Ordering Information
- Project Tips
- Ways to Enhance Your Product

www.officejetsupport.com

© 2002 Hewlett-Packard Company

Printed in the U.S.A., Mexico, Germany, Singapore, or China.



C8373-90101