

# HP LC3040N 30" HD Ready LCD TV HP LC2640N 26" HD Ready LCD TV Warranty and Support Guide



If you have any issues with your HP LCD TV, contact HP Total Care on the Web at <http://www.hp.com/us/support> or toll-free by phone: 1-(800) 474-6836

Write down the following information, which you will need if you contact HP for support. A sticker on your TV has the first three items printed on it.

Model Number: \_\_\_\_\_

Product Number: \_\_\_\_\_

Serial Number: \_\_\_\_\_

Purchase Date: \_\_\_\_\_



# Don't Forget to Register!

**Go to: <http://register.hp.com>**

Registration is quick and easy. The benefits include:

- E-mail updates containing notifications about product enhancements, the most recent support alerts, and driver updates specific to the product(s) you own.
- The HP Newsgram, our monthly online magazine packed full of product news, support tips, project ideas, and much more. Visit us at <http://subscription.support.hp.com>

## Getting Help

HP provides expert advice on using your HP TV or solving problems whether your product is in or out of warranty. Support options and availability vary by product, country/region, and language.

The HP support process works most effectively if you seek assistance in the following order:

- 1** Reference your product setup poster or the *User's Guide* for information on setup and general troubleshooting.
- 2 HP e-Support** offers instant access to support information and helpful tips, 24 hours a day, seven days a week. You can also send e-mail to our online support technicians to help resolve any issues. These services require access to the Internet. To learn more, visit our Customer Care Web site at <http://www.hp.com/us/support>
- 3 HP Total Care** is available toll-free by phone 24 hours a day, seven days a week. HP can diagnose product issues and coordinate a repair if necessary. A repair covered by the limited warranty is free during the limited warranty period. After the warranty period, you will be quoted a repair cost. HP Total Care can be contacted at: 1-(800) 474-6836 [1-(800) HP invent].

When you call, please have your TV model number, product number, serial number, and date of purchase available. Telephone support is free during your limited warranty period.

## Pixel Policy

In some cases, an LCD panel may have pixels that do not operate properly. This is common to all LCD displays used in products supplied by all vendors and is not specific to this product. A pixel consists of one red, one green, and one blue subpixel.

Pixels not operating properly are categorized into two types.

- A *dark pixel*, where the whole pixel is always off.
- A *bright pixel*, where the whole pixel is always on.

If your LCD TV contains one or more bright pixels or six or more dark pixels, HP can provide a replacement for you.

## Installation

If you intend to mount your TV using a wall mounting bracket or install your TV into a recessed wall cavity, HP recommends using a qualified installation service. Damage resulting from a custom installation is not covered under warranty. The warranty does not cover uninstalling or reinstalling a custom installation of your TV. You may need to have your TV removed from the wall or recessed area before a service technician arrives for warranty repair or replacement.

# Warranty and License Information

## Getting Repair

### In-home service

If your TV has been diagnosed with an internal component issue, we can schedule a convenient time for a qualified service technician to come and repair your product. This service is included as part of your product warranty.

### Advanced unit replacement

If a bench repair is required to fix your product, HP will arrange to have a replacement unit delivered to you and will pick up your defective TV. We pay for all shipping and handling. This service is free for the duration of the hardware warranty period.

## Protect Your Investment

### Obtaining a warranty upgrade

Upgrade your standard factory warranty to two or three years with an extended service plan. Service coverage begins on product purchase date, and you must purchase the service within the first year after purchasing the TV.

For more information visit

<http://www.hp.com/home/ownerservices>

(in the U.S. only).

Or call (866) 234-1377.

## HP Out-of-Warranty Support Options

Even after your warranty has ended, HP Total Care can still provide you with a range of services and support options:

- For Visa and MasterCard holders in the United States or calls from Canada, call 1-(800) 474-6836 [1-(800) HP invent]. Prices are subject to change without notice and may vary based on your product.

Fees are charged to your Visa or MasterCard.

## Recycle: HP Planet Partners

HP is sensitive to the environment and has a program, Planet Partners, to make it simple for us to reclaim your old product for recycling. HP will help you recycle your old equipment even if it is not an HP product; we take back all makes and models. Visit our Web site at <http://www.hp.com/recycle> to find out how easy it is to recycle.

## The Legal Language

### Hardware Limited Warranty

Original systems	1 year
Technical phone assistance to diagnose potential hardware issues	1 year

### General Terms

This HP Hardware Limited Warranty gives you, the customer, express limited warranty rights from HP, the manufacturer. Please refer to HP's Web site for an extensive description of your limited warranty entitlements. In addition, you may also have other legal rights under applicable local law or special written agreement with HP.

EXCEPT AS EXPRESSLY SET FORTH IN THIS LIMITED WARRANTY, HP MAKES NO OTHER WARRANTIES OR CONDITIONS, EXPRESS OR IMPLIED, INCLUDING ANY IMPLIED WARRANTIES OF MERCHANTABILITY AND FITNESS FOR A PARTICULAR PURPOSE. HP EXPRESSLY DISCLAIMS ALL WARRANTIES AND CONDITIONS NOT STATED IN THIS LIMITED WARRANTY. ANY IMPLIED WARRANTIES THAT MAY BE IMPOSED BY LAW ARE LIMITED IN DURATION TO THE LIMITED WARRANTY PERIOD. SOME STATES OR COUNTRIES/REGIONS DO NOT ALLOW A LIMITATION ON HOW LONG AN IMPLIED WARRANTY LASTS OR THE EXCLUSION OR LIMITATION OF INCIDENTAL OR CONSEQUENTIAL DAMAGES FOR CONSUMER PRODUCTS. IN SUCH STATES OR COUNTRIES/REGIONS, SOME EXCLUSIONS OR LIMITATIONS OF THIS LIMITED WARRANTY MAY NOT APPLY TO YOU.

THE LIMITED WARRANTY TERMS CONTAINED IN THIS STATEMENT, EXCEPT TO THE EXTENT LAWFULLY PERMITTED, DO NOT EXCLUDE, RESTRICT, OR MODIFY BUT ARE IN ADDITION TO THE MANDATORY STATUTORY RIGHTS APPLICABLE TO THE SALE OF THIS PRODUCT TO YOU.

This Limited Warranty is applicable in all countries/regions and may be enforced in any country/region where HP or its authorized service providers offer warranty service subject to the terms and conditions set forth in this Limited Warranty. However, warranty service availability and response times may vary from country/region to country/region and may also be subject to registration requirements in the country/region of purchase. If so, your HP authorized service provider can provide you with details.

This Limited Warranty applies only to HP-branded products (referred to in this Limited Warranty as “HP Hardware Products”) sold by or leased from Hewlett-Packard Company, its worldwide subsidiaries, affiliates, authorized resellers, or country/region distributors (collectively referred to in this Limited Warranty as “HP”) with this Limited Warranty. The term “HP Hardware Product” is limited to the hardware components and required firmware. The term “HP Hardware Product” DOES NOT include any software applications or programs; non-HP products or non-HP branded peripherals. All non-HP products or non-HP branded peripherals external to the HP Hardware Product — such as speakers, DVD players and video cables — are provided “AS IS” without HP warranty. However, non-HP manufacturers and suppliers, or publishers may provide their own warranties directly to you.

HP warrants that the HP Hardware Products that you have purchased or leased from HP are free from defects in materials or workmanship under normal use during the Limited Warranty Period. The Limited Warranty Period starts on the date of purchase or lease from HP, or from the date HP completes installation. Your dated sales or delivery receipt, showing the date of purchase or lease of the product, is your proof of the purchase or lease date. You may be required to provide proof of purchase or lease as a condition of receiving warranty service. You are entitled to hardware warranty service according to the terms and conditions of this document if a repair to your HP Hardware Product is required within the Limited Warranty Period.

Unless otherwise stated, and to the extent permitted by local law, new HP Hardware Products may be manufactured using new materials or new and used materials equivalent to new in performance and reliability. HP may repair or replace HP Hardware Products (a) with new or previously used products or parts equivalent to new in performance and reliability, or (b) with equivalent products to an original product that has been discontinued. Replacement parts are warranted to be free from defects in material or workmanship for ninety (90) days, or for the remainder of the Limited Warranty Period of the HP Hardware Product they are replacing or in which they are installed, whichever is longer.

During the Limited Warranty Period, HP will, at its discretion, repair or replace any defective component. All component parts or hardware products removed under this Limited Warranty become the property of HP. In the unlikely event that your HP Hardware Product has recurring failures, HP, at its sole discretion, may elect to provide you with (a) a replacement unit of HP’s choosing that is the same or equivalent to your HP Hardware Product in performance or (b) to give you a refund of your purchase price or lease payments (less interest) instead of a replacement. This is your exclusive remedy for defective products.

## **Exclusions**

HP does not warrant that the operation of this product will be uninterrupted or error-free. HP is not responsible for damage that occurs as a result of your failure to follow the instructions intended for the HP Hardware Product.

This Limited Warranty does not apply to expendable or consumable parts and does not extend to any product from which the serial number has been removed or that has been damaged or rendered defective (a) as a result of accident, misuse, abuse, contamination, improper or inadequate maintenance or calibration or other external causes; (b) by operation outside the usage parameters stated in the user documentation that shipped with the product; (c) by software, interfacing, parts or supplies not supplied by HP; (d) improper site preparation or maintenance; (e) loss or damage in transit; or (f) by modification or service by anyone other than (i) HP, (ii) an HP authorized service provider, or (iii) your own installation of end-user replaceable HP or HP approved parts if available for your product in the servicing country/region.

## **Exclusive Remedy**

TO THE EXTENT ALLOWED BY APPLICABLE LOCAL LAW, these terms and conditions constitute the complete and exclusive warranty agreement between you and HP regarding the HP Hardware Product you have purchased or leased. These terms and conditions supersede any prior agreements or representations — including representations made in HP sales literature or advice given to you by HP or an agent or employee of HP — that may have been made in connection with your purchase or lease of the HP Hardware Product. No change to the conditions of this Limited Warranty is valid unless it is made in writing and signed by an authorized representative of HP.

## Limitation of Liability

IF YOUR HP HARDWARE PRODUCT FAILS TO WORK AS WARRANTED ABOVE, HP'S MAXIMUM LIABILITY UNDER THIS LIMITED WARRANTY IS EXPRESSLY LIMITED TO THE LESSER OF THE PRICE YOU HAVE PAID FOR THE PRODUCT OR THE COST OF REPAIR OR REPLACEMENT OF ANY HARDWARE COMPONENTS THAT MALFUNCTION IN CONDITIONS OF NORMAL USE.

EXCEPT AS INDICATED ABOVE, IN NO EVENT WILL HP BE LIABLE FOR ANY DAMAGES CAUSED BY THE PRODUCT OR THE FAILURE OF THE PRODUCT TO PERFORM, INCLUDING ANY LOST PROFITS OR SAVINGS OR SPECIAL, INCIDENTAL, OR CONSEQUENTIAL DAMAGES. HP IS NOT LIABLE FOR ANY CLAIM MADE BY A THIRD PARTY OR MADE BY YOU FOR A THIRD PARTY.

THIS LIMITATION OF LIABILITY APPLIES WHETHER DAMAGES ARE SOUGHT, OR A CLAIM MADE, UNDER THIS LIMITED WARRANTY OR AS A TORT CLAIM (INCLUDING NEGLIGENCE AND STRICT PRODUCT LIABILITY), A CONTRACT CLAIM, OR ANY OTHER CLAIM. THIS LIMITATION OF LIABILITY CANNOT BE WAIVED OR AMENDED BY ANY PERSON. THIS LIMITATION OF LIABILITY WILL BE EFFECTIVE EVEN IF YOU HAVE ADVISED HP OR AN AUTHORIZED REPRESENTATIVE OF HP OF THE POSSIBILITY OF ANY SUCH DAMAGES. THIS LIMITATION OF LIABILITY, HOWEVER, WILL NOT APPLY TO CLAIMS FOR PERSONAL INJURY.

THIS LIMITED WARRANTY GIVES YOU SPECIFIC LEGAL RIGHTS. YOU MAY ALSO HAVE OTHER RIGHTS THAT MAY VARY FROM STATE TO STATE OR FROM COUNTRY/REGION TO COUNTRY/REGION. YOU ARE ADVISED TO CONSULT APPLICABLE STATE OR COUNTRY/REGION LAWS FOR A FULL DETERMINATION OF YOUR RIGHTS.

## Limited Warranty Period

The Limited Warranty Period for an HP Hardware Product is a specified, fixed period commencing on the date of purchase. The date on your sales receipt is the date of purchase unless HP or your reseller informs you otherwise in writing.

## Types of Warranty Service

To enable HP to provide the best possible support and service during the Limited Warranty Period, you may be directed by HP to verify configurations, run HP diagnostics tests or use HP remote support solutions where applicable.

HP strongly encourages you to accept the use of, or to employ available support technologies provided by HP. If you choose not to deploy available remote support capabilities, you may incur additional costs due to increased support resource requirements. Listed below are the types of warranty support service that may be applicable to the HP Hardware Product you have purchased.

### In-home Warranty Service

Your HP Limited Warranty service may include In-home labor support to repair your hardware. HP provides In-home service during standard office hours. Standard office hours are typically 08.00 to 17.00, Monday through Friday, but may vary with local business practices. If your location is outside the customary service zone (typically 50km) response times may be longer or there may be additional charges. To locate the nearest HP authorized service provider refer to the HP Web site at: <http://www.hp.com/us/support>

HP may, at its sole discretion, determine if In-home warranty service is required. For example, in many cases, the defect can be fixed by the use of a Customer Self Repair (CSR) part that you are required to replace yourself based on instructions and documentation provided by HP. You are also required to co-operate with HP in attempting to resolve the problem over the telephone. This may involve performing routine diagnostic procedures, removing third party options and/or substituting options. In order to receive In-home support, you must: (a) have a representative present when HP provides warranty services at your site; (b) notify HP if products are being used in an environment which poses a potential health or safety hazard to HP employees or subcontractors; (c) subject to its reasonable security requirements, provide HP with sufficient, free, and safe access to and use of all facilities, information and systems determined necessary by HP to provide timely support; (d) ensure that all manufacturers labels (such as serial numbers) are in place, accessible, and legible; (e) maintain an environment consistent with product specifications and supported configurations.

If you require an HP representative to handle all component replacements, support uplift contracts are available at additional cost.

## **Advanced Unit Replacement Warranty Service**

Your HP Limited Warranty may include an advance unit replacement warranty service. Under the terms of the advanced unit replacement warranty service, if a unit is diagnosed as defective and requires the return of the product for bench repair, HP will ship a replacement product directly to you. On receiving the replacement unit, the defective unit must be returned to HP, within a defined period of time, normally fifteen (15) days. Packaging for the broken TV will be provided with the replacement TV. HP will incur all shipping and insurance costs to return the defective unit to HP. Failure to return the defective unit may result in HP billing you for the replacement product.

## **Customer Self Repair Warranty Service**

In countries/regions where it is available, your HP Limited Warranty may include a Customer Self Repair warranty service. If applicable, HP will determine in its sole discretion that Customer Self Repair is the appropriate method of warranty service. If so, HP will ship approved replacement parts directly to you to fulfill your HP Hardware Product warranty service. This will save considerable repair time. After you contact HP and the fault diagnosis identifies that the problem can be fixed using one of these parts, a replaceable part can be sent directly to you. Once the part arrives, replace the defective part pursuant to the provided instructions and documentation. If further assistance is required, call the HP Technical Support Center and a technician will assist you over the phone. In cases where the replacement part must be returned to HP, you must ship the defective part back to HP within a defined period of time, normally fifteen (15) days. The defective part must be returned with the associated documentation in the provided shipping material. Failure to return the defective product may result in HP billing you for the replacement. With a customer self repair, HP will pay all shipping and part return costs and determine the courier/carrier to be used. If customer self repair applies to you, please refer to your specific HP Hardware Product announcement. You can also obtain information on this warranty service on the HP Web site at: <http://www.hp.com/us/support>

## **Carry-in Warranty Service**

Under the terms of Carry-in service, you will be required to deliver your HP Hardware Product to an authorized service location for warranty repair. You must prepay any shipping charges, taxes, or duties associated with transportation of the product to and from the service location. In addition, you are responsible for insuring any product shipped or returned to an authorized service location and assume risk of loss during shipping.

## **Contacting HP**

If your product fails during the Limited Warranty Period and the suggestions in the product documentation do not solve the problem, you can receive support by doing the following:

Locate your nearest HP Support location via the World Wide Web at:

<http://www.hp.com/us/support>

Contact your authorized HP dealer or Authorized Service Provider and be sure to have the following information available before you call HP:

- Product serial number, model name, and model number
- Detailed questions

# Regulatory and Safety Information



**WARNING: The TV is heavy; be sure to use ergonomically correct lifting procedures when moving the TV.**

## Additional Safety Information

This product has not been evaluated for connection to an "IT" power system (an AC distribution system with no direct connection to earth, according to IEC 60950).

## AC Power Safety Warning



**WARNING: Install the TV near an AC outlet. The AC power cord is your main AC disconnecting device and must be easily accessible at all times. For your safety, the power cord provided with your TV has a grounded plug. Always use the power cord with a properly grounded wall outlet, to avoid the risk of electrical shock.**



**WARNING: Do not operate the TV with the cover removed.**



**WARNING: The TV is not user-serviceable. To prevent damage to the TV, have a qualified person repair or replace it.**



**WARNING: For your safety, always unplug the TV from its power source and from any telecommunications systems (such as CATV, SAT, or any other peripheral) before performing any service procedures. Failure to do so may result in personal injury or equipment damage. Hazardous voltage levels are inside the TV.**

## TV Antenna Connectors Protection

### External Television Antenna Grounding

If an outside antenna or cable system is connected to the product, be sure the antenna or cable system is electrically grounded so as to provide some protection against voltage surges and built-up static charges. Article 810 of the National Electrical Code, ANSI/NFPA 70, provides information with regard to proper electrical grounding of the mast and supporting structure, grounding of the lead-in wire to an antenna-discharge unit, size of grounding conductors, location of antenna-discharge unit, connection to grounding electrodes, and requirements for the grounding electrode.

## Lightning Protection

For added protection of any product during a lightning storm, or when it is left unattended and unused for long periods of time, unplug the product from the wall outlet and disconnect the antenna or cable system. This will prevent damage to the product from lightning and power line surges.

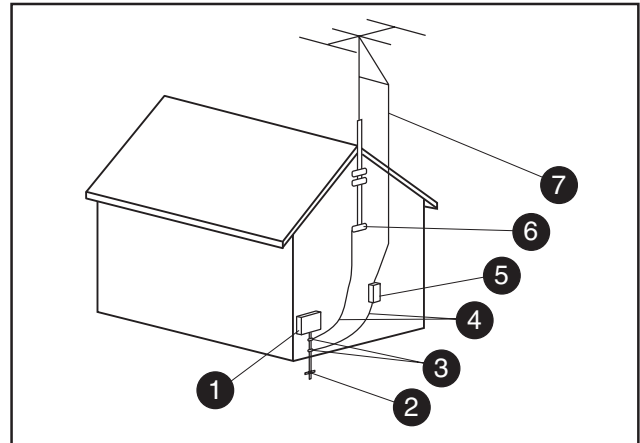

Antenna Grounding

Antenna Grounding

Reference	Grounding Component
1	Electric Service Equipment
2	Power Service Grounding Electrode System (NEC Art 250, Part H)
3	Ground Clamps
4	Grounding Conductors (NEC Section 810-21)
5	Antenna Discharge Unit (NEC Section 810-20)
6	Ground Clamp
7	Antenna Lead in Wire

## Power Lines

An outside antenna system should not be located in the vicinity of overhead power lines or other electric light or power circuits, or where it can fall into such power lines or circuits.



**WARNING: When installing an outside antenna system, extreme care should be taken to keep from touching such power lines or circuits as contact with them could be fatal.**



© 2004 Hewlett-Packard Development Company, L.P.

Printed in

[www.hp.com](http://www.hp.com)

