

1 HP Deskjet 6800 series printer



To find an answer to a question, click the appropriate topic below:

- [Notices](#)
- [Special features](#)
- [Getting started](#)
- [Connecting to the printer](#)
- [Printing from a digital camera](#)
- [Printing photos from a computer](#)
- [Printing other documents](#)
- [Printing tips](#)
- [Printer software](#)
- [Maintenance](#)
- [Troubleshooting](#)
- [Optional accessories](#)
- [Specifications](#)
- [Supplies](#)

2 Notices

- [Notices and acknowledgements](#)
- [Terms and conventions](#)

2.1 Notices and acknowledgements

Hewlett-Packard company notices

Reproduction, adaptation, or translation without prior written permission is prohibited, except as allowed under the copyright laws.

The information contained herein is subject to change without notice.

The only warranties for HP products and services are set forth in the express warranty statements accompanying such products and services. Nothing herein should be construed as constituting an additional warranty. HP shall not be liable for technical or editorial errors or omissions contained herein.

Acknowledgements

Apple, the Apple logo, AppleTalk, ColorSync, the ColorSync logo, Finder, Mac, Macintosh, MacOS, Powerbook, Power Macintosh, and Quickdraw are trademarks of Apple Computer, Inc., registered in the U.S. and other countries.

TrueType is a U.S. trademark of Apple Computer, Inc.

Adobe and Acrobat are trademarks of Adobe Systems Incorporated.

Â© 2004 Copyright Hewlett-Packard Development Company, L.P.

2.2 Terms and conventions

The following terms and conventions are used in the user's guide.

Terms

The HP Deskjet printer may be referred to as the **HP printer** or **printer**.

Cautions, warnings, and notes

A **Caution** indicates possible damage to the HP Deskjet printer or to other equipment. For example:



Caution: Do not touch the print cartridge ink nozzles or copper contacts. Touching these parts will result in clogs, ink failure, and bad electrical connections.

A **Warning** indicates possible harm to you or to others. For example:



Warning: Keep both new and used print cartridges out of the reach of children.

A **Note** indicates that additional information is provided. For example:

Note: For great results use HP products.

3 Special features

Congratulations! You have purchased an HP Deskjet printer that is equipped with several exciting features:

- **Built-in networking capabilities:** Connect to either a [wired](#) or a [wireless](#) network without using an external print server.
- **Ink-backup mode:** [Ink-backup mode](#) lets you continue printing with one print cartridge when the other print cartridge has run out of ink.
- **Print Cancel button:** Cancel print jobs at the touch of a [button](#).
- **Print multiple pages on a single sheet of paper:** Use the [printer software](#) to print up to 16 pages on a single sheet of paper.
- **Borderless printing:** Use the entire page surface when printing photos and cards by using the [borderless printing](#) feature.
- **Digital photo printing:** Use the enhanced [digital photo printing](#) capabilities.
- **Six-ink upgradeable printing:** Enhance photo printing with a [photo print cartridge](#).
- **Direct camera printing:** Use the [PictBridge port](#) on the front of the printer to print photographs directly from a digital camera.
- **Optional Automatic Two-Sided Printing Accessory:** Purchase a [Automatic Two-Sided Printing Accessory](#) to print two-sided documents automatically.
- **Optional Auto Two-Sided Print Accessory with Small Paper Tray:** Purchase a [Optional Auto Two-Sided Print Accessory with Small Paper Tray](#) to print two-sided documents automatically and load small media from the back of the printer.
- **Optional 250-Sheet Plain Paper Tray Accessory:** Purchase an optional [250-Sheet Plain Paper Tray Accessory](#) and expand the printer's paper-handling capability.



4 Getting started



For an overview of the printer features, see the [printer features](#) page.

Click the appropriate topic below for a description of a printer feature:

- [Buttons and lights](#)
- [Print Cartridge Status lights](#)
- [Paper trays](#)
- [Photo/envelope feeder](#)
- [Print cartridges](#)
- [Ink-backup mode](#)
- [Automatic Paper Type Sensor](#)
- [PictBridge port](#)

For a description of the optional accessories, see the [optional accessories](#) page.

4.1 Printer features

The HP printer has several features to make printing easier and more efficient.

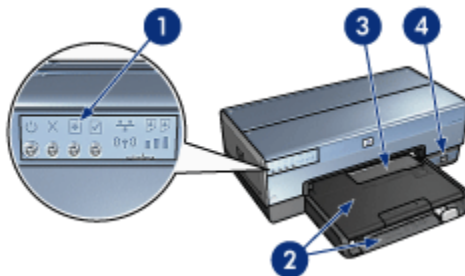

1. [Buttons and lights](#)

2. Paper trays
3. Photo/envelope feeder
4. PictBridge port

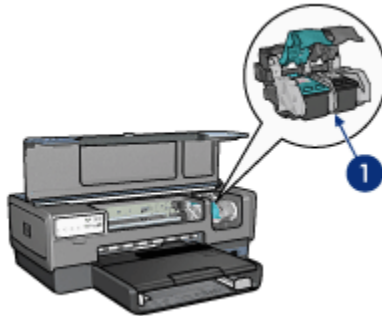

1. Print cartridges
2. Automatic Paper-Type Sensor (not illustrated)
3. Ink-backup mode (not illustrated)

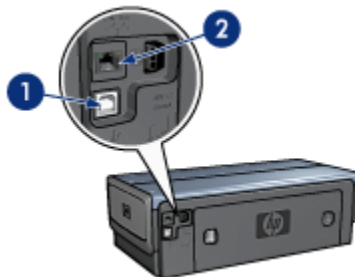

1. Rear USB port
2. Wired Ethernet port

Optional accessories



Automatic Two-Sided
Printing Accessory (optional)

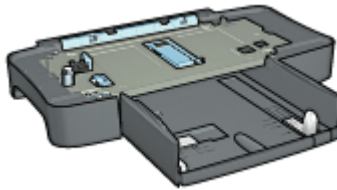

250-Sheet Plain Paper Tray
Accessory (optional)

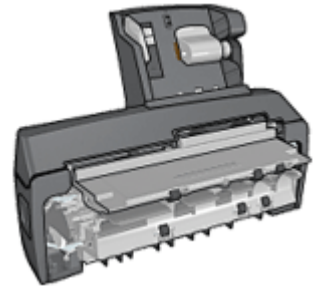

Auto Two-Sided Print
Accessory with Small Paper
Tray (optional)

4.2 Buttons and lights

Use the printer buttons to turn the printer on and off, cancel a print job, and restart a job. The printer lights give you visual cues about the status of the printer.

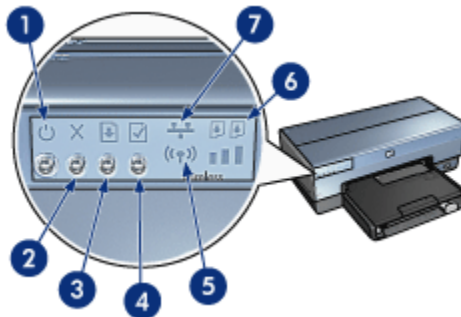

1. Power button and light
2. Print Cancel button
3. Resume button and light
4. Report Page button
5. Wireless Status light and Signal Strength indicator
6. Print Cartridge Status lights
7. Network icon

For a description of the following buttons and lights, click the appropriate option:

- [Report Page button](#)
- [Network icon](#)

- [Wireless Status light and Signal Strength indicator](#)
- [Print Cartridge Status lights](#)

Power button and light

The Power button turns the printer on and off. It might take a few seconds for the printer to turn on after you press the Power button.

The Power light flashes when the printer is processing.



Caution: Always use the Power button to turn the printer on and off. Using a power strip, surge protector, or a wall-mounted switch to turn the printer on and off can cause printer failure.

Print Cancel button

Pressing the Print Cancel button cancels the current print job.

Resume button and light

The Resume light flashes when an action is required, such as loading paper or clearing a paper jam. When the problem is solved, press the Resume button to continue printing.

4.3 Print Cartridge Status lights

The Print Cartridge Status lights indicate the status of the print cartridges.

Status of the Print Cartridge Status lights	Status of the print cartridges
On and solid	Low on ink
Flashing	Service required

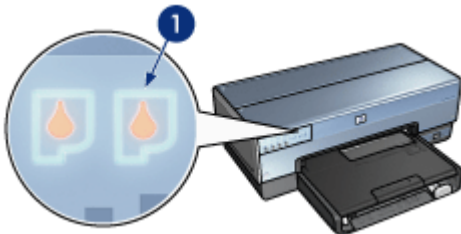

1. Print Cartridge Status lights

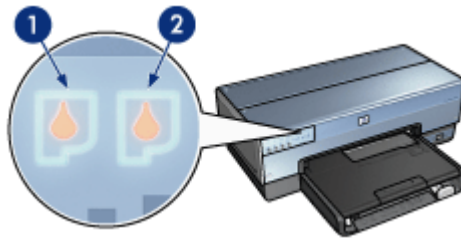

1. The **left** status light represents the tri-color print cartridge.
2. The **right** status light represents the print cartridge that is installed in the compartment on the right side of the print cartridge cradle. That print cartridge can be the black print cartridge, the photo print cartridge, or the gray photo print cartridge.

4.4 Paper trays

The printer has two paper trays:

- In tray
- Out tray

In tray

The In tray holds paper or other media to be printed.



1. In tray

Slide the paper guides firmly against the edges of the media on which you are printing.

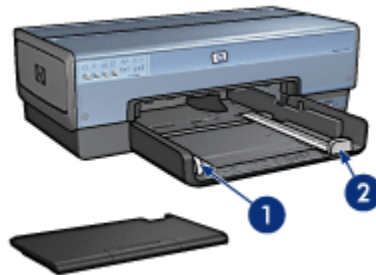

1. Paper-width guide
2. Paper-length guide

Out tray

Printed pages are deposited in the Out tray.



1. Out tray
2. Photo/envelope feeder

Use the [photo/envelope feeder](#) to print single envelopes, small photos, and cards.

Raise the Out tray to load paper.

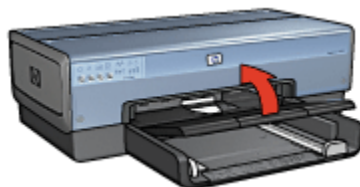

To prevent paper from falling out of the Out tray, pull out the Out-tray extension, and then unfold the Out-tray extension stop.



1. Out-tray extension
2. Out-tray extension stop

Do not unfold the Out-tray extension stop when printing on legal paper.

After the print job is complete, fold the Out-tray extension stop, and then push the Out-tray extension into the Out tray.

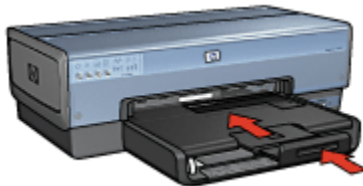

4.5 Photo/envelope feeder

Use the photo/envelope feeder to print the following documents:

- Envelopes
- Photos
- Postcards



1. Photo/envelope feeder

Envelopes

Follow these steps to use the photo/envelope feeder for single envelopes:

1. Insert the envelope with the side to be printed on facing down and the flap to the left.

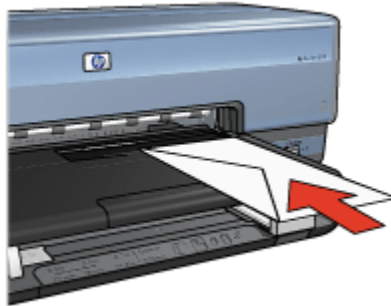

2. Push the envelope into the printer as far as it will go without bending.
3. Print the envelope.

Photos

Follow these steps to use the photo/envelope feeder to print a single photo:

1. Insert the photo paper into the photo/envelope feeder with the side to be printed on facing down.
2. Gently push the photo paper into the photo/envelope feeder as far as it will go without bending.



3. Slide the photo/envelope feeder forward as far as it will comfortably go.

Note: If the photo paper touches the back of the paper tray, you have pushed the feeder in as far as it needs to go.



4. Print the **photo**.

Postcards

Follow these steps to use the photo/envelope feeder to print a single postcard:

1. Insert the postcard into the photo/envelope feeder with the side to be printed on facing down.
2. Gently push the postcard into the photo/envelope feeder as far as it will go without bending.



3. Slide the photo/envelope feeder forward as far as it will go.



4. Print the **postcard**.

4.6 Print cartridges

Four print cartridges are available for use with the printer.



1. Black
2. Tri-color
3. Photo
4. Gray photo

Note: The availability of print cartridges varies by country/region.

Using print cartridges

Everyday printing

Use the black and tri-color print cartridges for everyday print jobs.

Quality color photos

For more vibrant colors when printing color photographs or other special documents, remove the black print cartridge and use a [photo print cartridge](#) in combination with the tri-color print cartridge.

Quality black and white photos

For outstanding black and white photographs, remove the black print cartridge and use a [gray photo print cartridge](#) in combination with the tri-color print cartridge.

Replacing print cartridges

When buying print cartridges, look for the print cartridge selection number.

You can find the selection number in these places:

- Selection number label: Look at the label on the print cartridge that you are replacing.

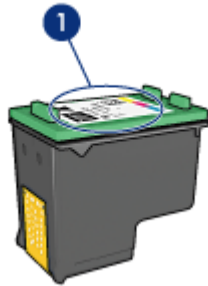

1. Selection number label

- Printer documentation: For a list of print cartridge selection numbers, see the reference guide that came with the printer.
- HP Inkjet Toolbox: Open the [HP Inkjet Toolbox](#), and then select the **Supplies** panel.

If a print cartridge runs out of ink, the printer can operate in the [ink-backup mode](#).

For information about installing a print cartridge, see the [print cartridge installation page](#).

4.7 Ink-backup mode

In the ink-backup mode, the printer operates by using only one print cartridge. The ink back-up mode is initiated when a print cartridge is removed from the print cartridge cradle.

To remove a print cartridge, see the [print cartridge installation page](#).

Ink-backup mode output

Printing in ink-backup mode slows the printer and affects the quality of printed documents.

Installed print cartridge	Result
Black print cartridge.	Colors are printed as grayscale.
Tri-color print cartridge.	Colors print but black is grayed and is not a true black.
Photo print cartridge.	Colors are printed as grayscale.
Gray photo print cartridge.	Colors are printed as grayscale.

Note: It is recommended that you do not use the photo print cartridge or the gray photo print cartridge for ink-backup mode.

Exiting ink-backup mode

Install two print cartridges in the printer to exit the ink-backup mode.

To install a print cartridge, see the [print cartridge installation](#) page.

4.8 Automatic Paper-Type Sensor

The Automatic Paper-Type Sensor automatically selects the appropriate print settings for the media that is being printed on, particularly HP media.

When the Automatic Paper-Type Sensor is engaged, the printer scans the first page of a document with a red optical sensor light to determine the best paper-type setting. After the printer determines the paper-type setting, the page is printed.

Do not place the printer in direct sunlight. Direct sunlight can interfere with the Automatic Paper-Type Sensor.

To use the Automatic Paper-Type Sensor, see the [paper-type selection](#) page.

Note: The Automatic Paper-Type Sensor is not available for documents that are printed from the [250-Sheet Plain Paper Tray Accessory](#) or the [Auto Two-Sided Print Accessory with Small Paper Tray](#).

5 Connecting to the printer

- [Connecting a digital camera](#)
- [USB](#)
- [Wireless networking](#)
- [Wired networking](#)

5.1 Printing photos from a digital camera

Learn how to print photos directly from a digital camera:

- [PictBridge description](#)
- [PictBridge printing instructions](#)
- [PictBridge troubleshooting](#)
- [Using the Auto Two-Sided Print Accessory with Small Paper Tray and PictBridge](#)

5.2 USB

The printer connects to the computer with a Universal Serial Bus (USB) cable.

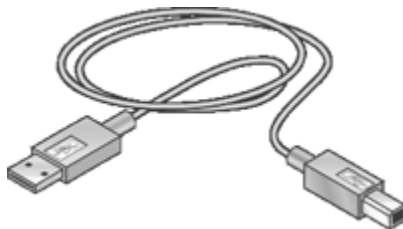

For instructions on connecting the printer with a USB cable, see the reference guide or setup poster that came with the printer.

5.3 Wireless networking

For setup information, click one of the following options:

- [Wireless network basics](#)
- [Wireless security](#)
- [Installing the printer on a wireless network](#)

For a description of the printer's wireless feature, click one of the following options:

- [Wireless Status light and Signal Strength indicator](#)
- [Report Page button](#)
- [Network icon](#)
- [Wireless radio](#)
- [HP Report page](#)
- [Embedded Web server \(EWS\)](#)

Other information:

- [Resetting the printer to the factory defaults](#)
- [Troubleshooting](#)
- [Glossary](#)

5.3.1 Wireless networking basics

The printer's built-in wireless communications feature allows you to connect the printer directly to an [802.11g](#) or [802.11b](#) Wi-Fi wireless network without the aid of an external print server.

To install the printer on a wireless network, follow the [wireless installation instructions](#).

Wi-Fi

802.11g and 802.11b

Wi-Fi is a wireless communications technology that allows you to connect computers and other devices (such as printers) to each other and the Internet without the use of wires. The printer is compatible with two types of Wi-Fi technology: 802.11g and 802.11b.

Both 802.11g and 802.11b operate by radio transmission in the 2.4 gigahertz per second (GHz) frequency band. 802.11g devices communicate at a maximum speed of 54 megabits per second (Mb/s). 802.11b devices communicate at a maximum speed of 11 Mb/s.

In [infrastructure mode](#), the printer operates in either 802.11g or 802.11b mode, depending on the wireless network. In [ad hoc mode](#), the printer defaults to 802.11b mode.

802.11a

802.11a is an emerging wireless networking technology that operates in the 5 GHz frequency band and offers communication speeds similar to those of 802.11g. The printer cannot communicate with 802.11a devices over a wireless connection.

If you have an 802.11a wireless network, you **must** use an [Ethernet cable](#) to connect the printer to the network's [Wireless Access Point \(WAP\)](#) in order to achieve a processing speed comparable to that of the 802.11a network.

To connect the printer to an Ethernet network, follow the [Ethernet network installation instructions](#).

Adapters and access points

Adapters

While some devices, such as the printer, have built-in Wi-Fi capability, other devices need an adapter to become Wi-Fi-enabled.

AirPort® cards are available from Apple for Macintosh products. See the card documentation for installation and configuration instructions.

Access points

A common variety of wireless network is called an [infrastructure network](#). An infrastructure network requires the use of a [Wireless Access Point \(WAP\)](#).

A WAP acts as a central hub for a wireless network or as a router connecting the wireless network to another network (such as the Internet or an Ethernet network). Devices on the network communicate through the WAP.



Macintosh users may use an AirPort® Base Station as a WAP.



Reducing interference in a wireless network

The following tips will help reduce the chances for interference in a wireless network:

- Keep the wireless devices away from large metal objects, such as filing cabinets, and other electromagnetic devices, such as microwaves and cordless telephones, as these objects can disrupt radio signals.
- Keep the wireless devices away from large masonry structures and other building structures as these objects can absorb radio waves and lower signal strength.
- For an infrastructure network, position the WAP in a central location in line of sight with the wireless devices on the network.
- Keep all wireless devices on the network within range of one another.

Wireless network examples

To see some examples of wireless networks, see the [wireless network examples page](#).

Communication modes

There are two types of communication modes for wireless devices:

- [Infrastructure mode](#)
- [Ad hoc mode](#)

Infrastructure mode

When the printer is set to the **infrastructure** communication mode, the printer communicates with other devices on the network, whether the devices are wired or wireless, through a [Wireless Access Point \(WAP\)](#). WAPs commonly act as [routers](#) or [gateways](#) on small networks.



In infrastructure mode, the printer automatically detects whether the wireless network uses 802.11b or 802.11g.

Ad hoc mode

When the printer is set to the **ad hoc**, or computer-to-computer, communication mode, the printer communicates directly with other wireless devices on the network without the use of a [WAP](#).

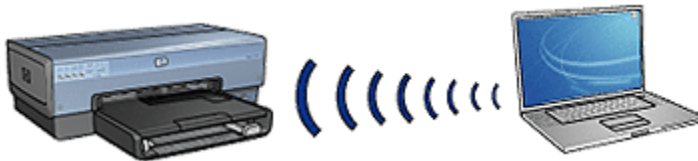

The **ad hoc** communication mode defaults to 802.11b. Follow these steps to use 802.11g in ad hoc mode:

1. Open the printer's [embedded Web server \(EWS\)](#).
2. Click the **Networking** tab.
3. Under **Connection**, click **Wireless (802.11)**.
4. Click the **Advanced** tab.
5. Under **Compatibility**, clear the **In an ad hoc network use 802.11b behavior** check box.
6. Click **Apply**, and then close the EWS.

Wireless network settings

Devices (such as computers and printers) on a wireless network must share the following settings:

Network name (SSID)

A network name, or "Service Set Identifier (SSID)," identifies a particular wireless network. In order to operate on a network, a device must know the network's network name.

For an in-depth explanation of network names, see the [network names page](#).

Network locations

A network location is a set of network settings unique to a given wireless network. A wireless device might have network locations for several wireless networks. In order to use the printer, the computer must be set to the network location for the printer's wireless network.

For example, a computer that is used both at work and at home, might have one network location for a wireless network at work and another network location for a wireless network at home.

The printer does not support multiple network locations.

For an in-depth explanation of network locations, click [here](#).

Wireless security

Devices on a wireless network must share the same security settings.

For a description of the wireless security options available for the printer, see the [wireless security page](#).

Printing

Computers on the network send print jobs directly to the printer, which prints them in the order received.

The printer can accept print jobs sent simultaneously from four users.

For example, if five users each send a print job to the printer at the same time, the printer accepts four of the print jobs and rejects the fifth. The user who sent the fifth print job should wait a few minutes and then resend the print job.

5.3.2 Wireless network examples

There are three common configurations for wireless networks:

- [Ad hoc](#)
- [Infrastructure](#)
- [Mixed wired and wireless](#)

Ad hoc networks

An ad hoc network, also called a computer-to-computer network, is a type of wireless network in which devices directly communicate with each other rather than through a [Wireless Access Point \(WAP\)](#).

For example, a simple ad hoc wireless network might consist of a laptop and a printer communicating directly with one another.

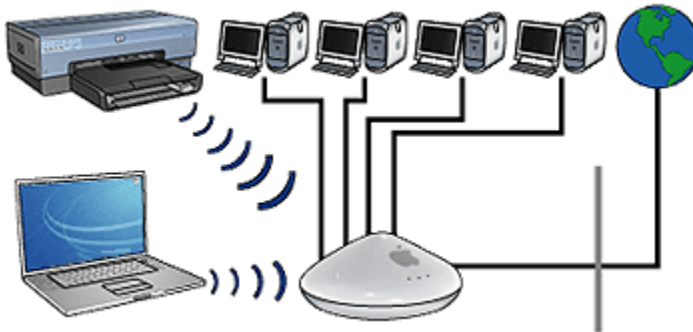

Ad hoc networks are typically small and simple. Performance on these types of networks can degrade if more than six devices are on the network.

Infrastructure networks

On an infrastructure network, devices, such as computers and printers, communicate through a **Wireless Access Point (WAP)**. WAPs commonly act as **routers** or **gateways** on small networks.

For example, a simple infrastructure wireless network might consist of a laptop and a printer communicating through a WAP.



Mixed wired and wireless networks

Wireless devices often exist on a largely wired network.

In this case, a **WAP** is connected to the main network by an Ethernet cable plugged into the WAP's WAN port. The WAP acts as the go-between for the wired devices and the wireless devices. The wired devices communicate with the WAP over the Ethernet cable, while the wireless devices communicate with the WAP over radio waves.

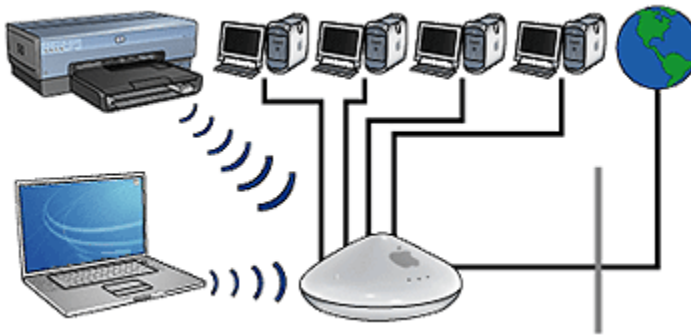

For example, a mixed wired and wireless network may consist of the following:

- Several desktop computers
- A WAP connected to an Ethernet network
- A printer connected wirelessly to the WAP

In order to use the printer, a desktop PC sends a print job over the Ethernet cable to the WAP. The WAP then wirelessly transmits the print job to the printer.

5.3.3 Network locations

A network location is a set of network settings unique to a given wireless network.

Many wireless devices have configuration utilities that allows the device to have network locations for several wireless networks. In order to use the printer, the computer must be set to the network location for the printer's wireless network.

Use the **Location Manager** control panel to create and edit network locations.

Note: Not all wireless devices support multiple network locations.

The printer only supports one network location.

Example

A person uses the same wireless-enabled laptop at work and at home. They have one wireless network at work, and another wireless network at home.

Each network has a unique set of wireless settings. The person creates the following network locations on the laptop:

- **at_work:** Contains the network settings for the office wireless network
- **at_home:** Contains the network settings for the home wireless network

Where the wireless network is	Network location settings
<p data-bbox="196 904 265 930">Office</p> 	<p data-bbox="614 1012 703 1038">at_work</p> <ul data-bbox="643 1055 1057 1159" style="list-style-type: none">• Network name: office• Communication mode: infrastructure• Security: WPA

Where the wireless network is is	Network location settings
<p>Home</p> 	<p>at_home</p> <ul style="list-style-type: none"> • Network name: home • Communication mode: ad hoc • Security: WEP

When the laptop is being used at work, the person must set the network location to **at_work** in order to connect to the office network.

Conversely, the laptop must be set to the **at_home** network location when the person is at home and wants to connect the laptop to the home network.

5.3.4 Network name (SSID)

A network name, or “Service Set Identifier (SSID)”, identifies a particular wireless network. In order to operate on a network, a device must know the network’s network name.

A wireless network only has one network name.

A given location, such as an office, may have several wireless networks, each with a different network name. Wireless devices use network names to identify overlapping wireless networks.

Example

The printer is in an office with two wireless **infrastructure** networks. Each network has a **Wireless Access Point (WAP)**.

Note: In this example, both wireless networks have the same security settings.



1. Network name equals "network_1"
2. Network name equals "network_2"

The network name for one wireless network is **network_1**. The network name for the other wireless network is **network_2**.

The printer receives signals from both networks, **network_1** and **network_2**.

The printer is configured for network_1

The printer's network name (SSID) setting has been configured for **network_1**. The printer can only communicate to **network_1**. In other words, the printer can only accept print jobs from **network_1**.



The printer communicates with network_1.

The laptop is configured for network_2

The laptop's network name (SSID) settings have been configured for **network_2**. The laptop is unable to communicate with the printer and cannot send print jobs to the printer.



The laptop cannot communicate with the printer.

The laptop is reconfigured for network_1

The laptop's network name (SSID) settings have been reconfigured for **network_1**. The laptop is able to communicate with the printer and is ready to send print jobs to **network_1**.



The laptop and the printer can communicate.

5.3.5 Wireless security

The printer can be configured for several wireless security options depending on the type of wireless network of which the printer is part.

Infrastructure networks

- WPA
- WEP
- Open system

Ad hoc networks (computer-to-computer)

- WEP
- Open system

Wireless security basics

For more information about wireless security, see the [authentication and encryption page](#).

5.3.6 Authentication and encryption

Wireless security is a complex and developing topic. This page gives a brief overview of the basics involved in making a wireless network secure.

In the simplest terms, wireless security involves two strategies: authentication and encryption.

A wireless security method, such as [WEP](#) or [WPA](#), involves varying levels of authentication and encryption.

Authentication

Definition

Authentication verifies the identity of a user or device before granting access to a network, making it more difficult for unauthorized users to access network resources.

In order to be authenticated and allowed to use a network, a device must supply a known password to other devices on the network. If the device cannot supply the correct password, then it will not be able to use other devices on the network.

Types of authentication

The printer supports three types of authentication. Each type of authentication has its benefits and limitations.

Authentication type	Description	Benefits	Limitations
Open System	Devices on a network identify themselves with the network name (SSID) only.	Least complicated strategy.	Provides little protection against unauthorized users.
Shared Key	Devices use a shared master secret to identify themselves as authorized members of the network.	Convenient to use in conjunction with WEP, since a WEP key can serve as the shared authentication key.	All devices must have the key. The shared key does not change automatically.
WPA/PSK	Devices use a single pre-shared key (PSK) to identify themselves as authorized members of the network and to generate an encryption key.	The pre-shared key and the encryption keys are not identical. Allows smaller networks to use WPA without the need for an authorization server.	All devices must have the key.

Encryption

Definition

Encryption involves using a password to encode data sent over a wireless network in order to make the data unintelligible to eavesdroppers. Only devices that know the password can decode the data.

Types of encryption

The printer supports four types of encryption. Each type of encryption has its benefits and limitations.

Encryption type	Description	Benefits	Limitations
Open System	Devices on a network do not encrypt data.	Least complicated strategy.	Provides no protection against eavesdroppers.
WEP encryption	Devices on a network share a password, called a "WEP key" to encode and decode data.	Simplest strategy that provides encryption.	All devices must have the key. The WEP key does not change automatically. WEP encryption provides less security than both AES or TKIP.

Encryption type	Description	Benefits	Limitations
AES	<p>Advanced Encryption Standard (AES) is a U.S. government sponsored encryption method that uses a complex algorithm called "Rijndael."</p> <p>AES uses encryption keys to encode data. AES automatically changes the encryption keys after a certain time interval, thus making the wireless network less vulnerable to eavesdropping.</p>	<p>Since the encryption key changes automatically, the data is more difficult for eavesdroppers to decode.</p>	<p>All devices must have the key.</p>
TKIP	<p>Temporal Key Integrity Protocol (TKIP) uses encryption keys to encode data. TKIP automatically changes the encryption keys after a certain time interval, thus making the wireless network less vulnerable to eavesdropping.</p>	<p>Since the encryption key changes automatically, the data is more difficult for eavesdroppers to decode.</p>	<p>All devices must have the key.</p>

5.3.7 Wi-Fi Protected Access (WPA)

Wi-Fi Protected Access (WPA) provides security by doing the following:

- Encrypting data sent over radio waves from one wireless device to another wireless device
- Controlling access to network resources through authentication protocols

Only devices that share the same WPA settings as the printer will be able to communicate with the printer.

For example, if the printer's network uses WPA, only devices that have the same WPA settings as the printer will be able to use the printer.

WPA provides better security than [WEP](#).

WPA is a network feature

WPA is an optional wireless network feature. Not all wireless networks use WPA.

Configure the printer for WPA only if the printer's network uses WPA. The printer's WPA settings must match the network's settings.

If the printer's network does not use WPA, then do not configure the printer to use WPA.

If you do not know if your network uses WPA, consult the configuration utility for your computer's NIC card or your network's [Wireless Access Point \(WAP\)](#).

Encryption

WPA uses encryption keys to encode data.

The printer supports two types of WPA encryption: TKIP and AES.

For more information about TKIP and AES, see the [authentication and encryption page](#).

Configuring the printer to use WPA

Follow these steps to configure the printer to use WPA:

1. Open the printer's [embedded Web server \(EWS\)](#).
2. Click the **Networking** tab.
3. Under **Connections**, click **Wireless (802.11)**.
4. On the **Wireless Setup** tab, click the **Start Wizard** button, and then follow the onscreen instructions
5. After configuring the printer, close the EWS.

5.3.8 Wired equivalent privacy (WEP)

Wired Equivalent Privacy (WEP) provides security by encrypting data sent over radio waves from one wireless device to another wireless device.

WEP can also provide security through authentication. For more information about authentication and encryption, see the [authentication and encryption page](#).

WEP encodes the data sent across the network making the data unintelligible to eavesdroppers. Only devices that share the same WEP settings as the printer will be able to communicate with the printer.

For example, if the printer's network uses WEP, only devices that have the same WEP settings as the printer will be able to use the printer.

WEP is a network feature

WEP is an optional wireless network feature. Not all wireless networks use WEP.

Configure the printer for WEP only if the printer's network uses WEP. The printer's WEP settings **must** match the network's settings. If your network has WEP, you must use an Ethernet cable to connect the printer to the network in order to install the printer software.

If the printer's network does not use WEP, then do not configure the printer to use WEP.

If you do not know if your network uses WEP, consult the configuration utility for your computer's NIC card or your network's [Wireless Access Point \(WAP\)](#).

WEP keys

Devices on a WEP-enabled network use [WEP keys](#) to encode data.

WEP keys can also be used for authentication.

After creating a set of WEP keys, record and store the keys in a secure location. You may not be able to retrieve the WEP keys if you lose them.



Caution: If you lose the WEP keys, you will not be able to add a new device to your network without reconfiguring the WEP settings for every device on the network.

A WEP-enabled network might use multiple WEP keys. Each WEP key is assigned a key number (such as Key 2). Each device on the network must recognize all the network's WEP keys and the key number assigned to each WEP key.

Configuring the printer to use WEP

Follow these steps to configure the printer to use WEP:

1. Open the printer's [embedded Web server \(EWS\)](#).
2. Click the **Networking** tab.
3. Under **Connections**, click **Wireless (802.11)**.
4. On the **Wireless Setup** tab, click the **Start Wizard** button, and then follow the onscreen instructions
5. After configuring the printer, close the EWS.

5.3.9 Open system

A wireless network that does not use any authentication or encryption method is referred to as an “open system.”

An open system can still have a minor level of security if the network's wireless access point(s) does not broadcast the network's network name (SSID). A device trying to join the network must then know the network name before connecting.

For more information about network names, see the [network name \(SSID\)](#) page.

An open system is highly vulnerable to eavesdropping and intrusion.

Configuring the printer for an open system

Follow these steps to configure the printer for an open system:

1. Open the printer's [embedded Web server \(EWS\)](#).
2. Click the **Networking** tab.
3. Under **Connections**, click **Wireless (802.11)**.
4. On the **Wireless Setup** tab, click the **Start Wizard** button, and then follow the onscreen instructions
5. After configuring the printer, close the EWS.

5.3.10 Installing the printer on a wireless network

For instructions on installing the printer on a wireless network, see the network guide that came with the printer.

5.3.11 Wireless Status light

The Wireless Status light indicates the status of the printer's internal wireless communications radio.

State of the Wireless Status light	Printer status
 <p>On</p>	<p>Able to receive and transmit data wirelessly.</p>

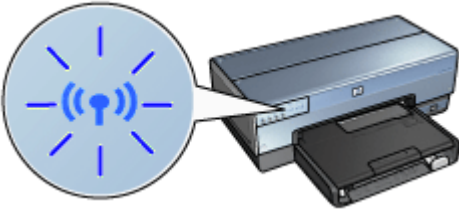
State of the Wireless Status light	Printer status
 <p>Off</p>	<p>Is not able to receive and transmit data wirelessly.</p>
 <p>Flashing</p>	<p>Receiving data.</p>

Signal Strength indicator

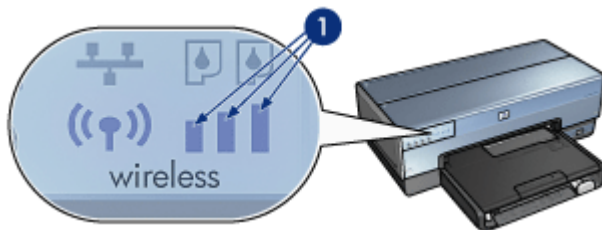

The Signal Strength indicator shows the strength of the radio signal that the printer is receiving. When all bars are illuminated, the signal is strong. When no bars are illuminated, the signal is weak.

5.3.12 Report Page button

Use the Report Page button to do the following:

- [Print an HP Report page](#)
- [Reset the printer to the factory defaults](#)

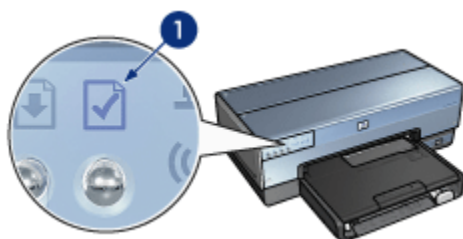



1. Report Page button

5.3.13 Network icon

The Network icon illuminates when the printer is connected to:

- An **Ethernet** network
- An active **wireless** network
- An active wireless direct-connection to a computer or other wireless device

Status of the icon	Status of the printer network connection
 <p>On</p>	<p>Connected to either an Ethernet network or a wireless network.</p>
 <p>Off</p>	<p>Not connected to an Ethernet network or a wireless network.</p>

5.3.14 Wireless radio

The printer has an internal wireless radio for wireless communication.

How the wireless radio works

The wireless radio broadcasts on the 2.4 GHz frequency whenever the wireless radio is powered on and enabled.

The wireless radio automatically turns off when the printer is powered off or unplugged from a power source.

If the printer is connected to an active Ethernet network with an Ethernet cable, the wireless radio remains active, but the printer does not attempt to make a wireless connection.

Note: USB connections have no effect on the radio's functionality.

Wireless Status light

The Wireless Status light indicates the status of the wireless radio. For a description of the Wireless Status light, see the [Wireless Status light page](#).

Disabling and enabling the wireless radio

Disabling the radio turns the wireless radio off. When disabled, the wireless radio sends no signals even if the printer is powered on.

Enabling the radio turns the wireless radio on. When enabled, the wireless radio sends signals if the printer is powered on.

Disabling the wireless radio

Follow these wireless steps to disable the radio:

1. Verify that the printer is powered on and is idle.
2. Press and hold down the **Report Page** button.
3. While holding down the **Report Page** button, press the **Cancel** button once, and then press the **Resume** button once.
4. Release the **Report Page** button.

Enabling the wireless radio

Follow these steps to re-enable the wireless radio:

1. Verify that the printer is powered on and is idle.
2. Press and hold down the **Report Page** button.
3. While holding down the **Report Page** button, press the **Cancel** button once.
4. Release the **Report Page** button.

5.3.15 HP Report page

The HP Report page supplies useful information about the printer's [wireless](#), [wired](#), and [PictBridge](#) connections.

Printing an HP Report page

To print an HP Report page, verify that the printer is powered on and idle, and then press the **Report Page** button once.

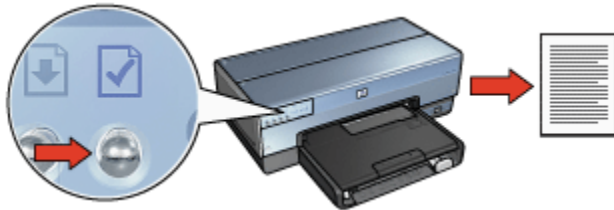

If the printer has just been connected to a network, wait a few minutes before printing the HP Report page to allow the printer to obtain valid settings.

Selecting the language

The default language for the HP Report page is English. Follow these steps to print the page in another language:

1. Press the **Report Page** button to print the English version of the page.
2. On the lower portion of the page, find the language that you want.
3. To print the page in that language, follow the instructions that correspond to the language.

For example, to print the page in French, press and hold down the **Report Page** button, press the **Resume** button twice, and then release the **Report Page** button.

Understanding the HP Report page

The HP Report page lists the following information that you might frequently need to know:

General information

General information applies to both Ethernet and wireless networks:

Item	Meaning
Network Status	The printer's network status: <ul style="list-style-type: none"> • Ready: The printer is ready to print. • Offline: The printer is not connected to a network.
Active Connection Type	The type of network the printer is connected to: <ul style="list-style-type: none"> • Wired: The printer is connected to an Ethernet network. • Wireless: The printer is connected to a wireless network. • Disabled: The printer is not connected to a network.
URL	The address to use in order to open the printer's embedded Web server .
Hardware Address (MAC)	The printer's Media Access Control (MAC) address .
Firmware Revision	Revision number of the printer's internal software. This item may be requested by HP Service and Support.
Host Name	The printer's host name on the network.
IP Address	The printer's current IP address on the network.
Subnet Mask	The printer's subnet mask .
Default Gateway	The printer's gateway address.
Configuration Source	How the printer obtained its IP address: <ul style="list-style-type: none"> • Automatic: AutoIP or DHCP • Manual: Static IP address
DNS Server	The IP address of the printer's domain name server. Not Specified means that no IP address has been set. This setting does not apply to the printer.
mDNS	The printer's mDNS service name on the network. This name is used by Apple Rendezvous to identify the printer on Mac OS X v10.2.3 and higher.
Admin Password	Indicates whether the printer's embedded Web server is password protected. <ul style="list-style-type: none"> • Set: A password is required. • Not Set: A password is not required.

Item	Meaning
Link Config	<p>The network link configuration:</p> <ul style="list-style-type: none"> • 802.11 • 10T-Full • 10T-Half • 100TX-Full • 100TX-Half

802.11 wireless

The 802.11 wireless information applies only to the printer's wireless connection:

Item	Meaning
Wireless Status	<p>The printer's wireless network status:</p> <ul style="list-style-type: none"> • Connected: The printer is connected to the wireless network. • Disconnected: The printer is not connected to the wireless network. • Disabled: The wireless radio is off and the printer is connected to an Ethernet network.
Communication Mode	<p>The communication mode to which the printer is configured.</p> <ul style="list-style-type: none"> • Infrastructure • Ad hoc
Network Name (SSID)	<p>The SSID setting to which the printer is set.</p>
Signal Strength (1-5 highest)	<p>The strength of the 802.11 radio signal the printer is receiving:</p> <ul style="list-style-type: none"> • 1 through 5: 5 indicates an excellent signal; 1 indicates a poor signal. • Not applicable: The printer is set to ad hoc communication mode or the wireless network is disabled.

Item	Meaning
Channel	<p>One of several pre-set frequencies at which 802.11b-enabled devices communicate in order to reduce interference.</p> <p>The number of channels available varies by country/region.</p> <p>Not applicable means that the wireless network is disabled.</p>
Authentication Type	<p>The printer's authentication setting:</p> <ul style="list-style-type: none"> • Open System: No authentication is being used. • Shared Key: The printer is using a WEP key for authentication. • WPA-PSK: Authentication that uses a Pre-Shared Key (PSK). Used as part of WPA for small networks. • None: No authentication is in use.
Encryption	<ul style="list-style-type: none"> • 64-bit WEP: Printer is configured with a five-character or 10-digit WEP key. • 128-bit WEP: Printer is configured with a 13-character or 26-digit WEP key. • AES: An encryption method that can be used with WPA. • TKIP: An encryption method that can be used with WPA. • None: No encryption is being used.
Access Point HW address	<p>The MAC address of the Wireless Access Point (WAP) for the printer's network. This setting applies only to infrastructure networks. Not applicable means that the printer is set to ad hoc communication mode.</p>

Miscellaneous

The Miscellaneous section contains information that applies to Ethernet networks, wireless connections, and PictBridge connections:

Item	Meaning
Total Packets Transmitted	Number of packets sent without error. This item may be requested by HP Service and Support.
Total Packets Received	Number of packets received without error. This item may be requested by HP Service and Support.
PictBridge Status	<ul style="list-style-type: none"> • Connected: The printer is connected to a digital camera. • Error: Something is wrong with the PictBridge connection.
PictBridge Last Error	The last known error to occur in the printer PictBridge function since the printer was last turned on.

5.3.16 Embedded Web server (EWS)

The embedded Web server (EWS) provides a simple way to manage your printer on a network.

	<p>Use the printer's EWS to do the following:</p> <ul style="list-style-type: none"> • Check the printer's status. • Adjust the printer's network configuration. • Check estimated ink levels in the print cartridges. • View network statistics. • Configure the printer's wireless security settings. • Visit HP's Web site for support information and to purchase supplies.
--	--



Caution: It is recommended that the printer and the computers that use it be on the same subnet. Printer installation across subnets can be problematic depending on the type of router used.

Before using the EWS, verify that the printer and the computer are powered on and connected to the network.

Follow these steps to open the EWS:

1. Launch your Internet browser.

Use Microsoft Internet Explorer 5.0 or higher or Netscape 4.75 or higher.

2. Enter the printer's [IP address](#) in the browser's address box.

Note: If your computer uses a proxy server to access the Internet, you might need to configure your browser to by-pass the proxy server in order to access the EWS.

If you do not know the printer IP address, [print an HP Report page](#).

Note: For instructions on using the printer's EWS, see the online help. To open the online help, click **Help** under the **Other Links** heading.



Caution: Use caution when changing the print server's wireless network settings; you may lose your connection. If you lose your connection, you may need to use the new settings to reconnect. If the printer loses its network connection, you may need to reset it to factory defaults and reinstall the software.

5.3.17 Resetting the printer to the factory default settings

Once the printer is configured for a network, its configuration settings are saved in its memory.

Resetting the printer to its factory default settings will clear all the settings from the printer's memory for your network. This should only be done as a last resort when troubleshooting the printer.

Resetting the printer to its factory default settings may require you to reinstall the printer software. Additionally, you will also have to reconfigure the printer's security settings.

The printer's default settings are:

Option	Default setting
Communication mode	Ad hoc
Network Name (SSID)	hpsetup
Encryption	None
Wireless radio	On
EWS administrator password	[blank]

Follow these steps to reset the printer to the factory default settings:

1. Verify that the printer is powered on.
2. Press and hold down the **Report Page** button.

3. While holding down the **Report Page** button, press the **Cancel** button three times.
4. Release the **Report Page** button.

5.3.18 Networking glossary

numbers

10/100 Base-T: A technical term for Ethernet. 10/100 refers to the speed at which the Ethernet network functions. 10 indicates 10 megabits per second (Mb/s) for normal Ethernet, and 100 indicates 100 Mb/s for Fast Ethernet.

802.11a: A type of wireless networking that provides up to 54 Mb/s transmission in the 5 GHz band.

802.11b: A type of wireless networking that provides up to 11 Mb/s transmission (with a fallback to 5.5, 2 and 1 Mb/s) in the 2.4 GHz band.

802.11g: A type of wireless networking that provides up to 54 Mb/s transmission in the 2.4 GHz band.

a

Ad hoc network: A type of wireless network in which devices directly communicate with each other rather than through a Wireless Access Point (WAP). Ad hoc networks are typically small and simple (for example, two wireless PCs or a wireless PC and a wireless printer). Performance on these types of networks can degrade if more than six devices are on the network. Ad hoc networks are also known as peer-to-peer networks, independent basic service stations (IBSS), or direct-connect wireless networks.

AES: Advanced Encryption Standard (AES) is a U.S. government sponsored encryption method that uses a complex algorithm called "Rijndael." AES uses encryption keys to encode data. AES automatically changes the encryption keys after a certain time interval, thus making the wireless network less vulnerable to eavesdropping.

Authentication: Authentication is a wireless network security strategy. On a network with authentication, devices use a shared key as a password and communicate only with devices that know the key. Authentication does not encrypt the data sent between wireless devices. Authentication can be used in conjunction with WEP. Authentication keys and WEP keys can be identical.

AutoIP: A process by which a device on a network automatically assigns an IP address to itself.

b

BOOTP: Bootstrap Protocol (BOOTP) is an Internet protocol that enables a device to discover its own IP address, the IP address of a BOOTP server on the network, and a file to be loaded into memory to boot the machine. This enables the device to boot without requiring a hard or floppy disk drive.

Broadcast packet: A packet sent from one device on a network to all devices on the network.

c

Channel: One of several pre-set frequencies at which 802.11b-enabled devices communicate in order to reduce interference. The number of channels available varies by country/region.

d

DHCP (Dynamic Host Configuration Protocol): A protocol used to automatically assign an IP address to each device on a network.

e

EAP: Extensible Authentication Protocol (EAP) is a general protocol for authentication that also supports multiple authentication methods, such as token cards, one-time passwords, certificates, and public key authentication. [WPA](#) uses EAP.

Encryption: A network security that encodes the data sent across a wireless network making the data unintelligible to eavesdroppers. The printer supports [WEP](#), [TKIP](#), and [AES](#).

Encryption keys: A sequence of characters or digits that a wireless device uses to encode data. Encryption keys can be static (as they are in [WEP](#)) or dynamic (as they are in [WPA](#)).

Ethernet: A popular form of wired computer networking for Local Area Networks.

Ethernet cable: There are two types of Ethernet cables. A straight-through cable is the most common and is used to connect devices on a network to a hub or router. A crossover cable is used to connect two devices that have Ethernet ports but that are not hubs or routers. Use a CAT-5 cable with an RJ-45 plug to connect the printer to an Ethernet network.

f

Firewall: A combination of hardware and software tools that protects a network from unwanted entry.

g

Gateway: A dedicated device (router or computer) that connects two different networks. For example, a computer on an Ethernet network may act as a gateway between the network and the Internet.

h

Host name: The name by which the printer identifies itself on the network. The printer's host name appears on the HP Report page. Use the host name to open the printer's embedded Web server (EWS).

Hub: A simple device that acts as the center of an Ethernet network. Other devices on the network are connected to the hub.

i

ICS (Internet Connection Sharing): A Windows program that allows a computer to act as a gateway between the Internet and a network. ICS uses DHCP to assign IP addresses. See Windows documentation for more information about ICS.

Internet Sharing: A Macintosh OSX program that allows a computer to act as a gateway between the Internet and a network. See Macintosh documentation for more information about Internet Sharing.

IP address (Internet Protocol address): A unique number that identifies a device on a network. The IP address is often automatically assigned by DHCP or AutoIP. However, a device can be manually assigned a static IP address.

Infrastructure network: A type of wireless network in which devices communicate with each other through a Wireless Access Point (WAP), such as a wireless network hub, router, or gateway.

l

LAN (Local Area Network): A high-speed type of computer network that connects devices that are a relatively short distance from one another. An Ethernet network is one type of LAN.

m

MAC address (Media Access Control address): The hardware address for a device on a network. The printer's MAC address appears on the HP Report page.

Mb/s (megabits per second): The measure for the rate at which a network functions. For example, 1 Mb/s equals 1,000,000 bits per second (or 125,000 bytes per second).

mDNS: As an alternative to a Domain Name Server, a device issues a Multicast Domain Name Server (mDNS) notification to provide information regarding its service. The notification includes the type of service (such as printing), the name of the service (such as "your printer"), IP and port addresses, and other necessary information. Each device on the network receives the notification and stores the information in a personal DNS server.

n

Network name: A network name is an alphanumeric, case-sensitive character string that provides basic access control to a wireless network. A network name is also known as a "Service Set Identifier (SSID)."

p

Packet: A message sent from one device on a network to other devices on the network.

Protocol: A language that devices on a network use to communicate with each other. A popular network protocol is TCP/IP.

r

RJ-45: The type of plug at the end of an Ethernet cable.

Router: A complex networking device that directs packets from one network to another network. A router can act as a gateway between a LAN and the Internet.

s

Static IP address: An IP address that is manually assigned to a device on a network. A static IP address remains fixed until changed manually. Alternative methods for assigning IP address are DHCP and AutoIP.

Subnet: A small network that acts as part of a large network. It is recommended that the printer and the computers that use the printer all be on the same subnet.

Subnet mask: A number that identifies the IP addresses that belong to a subnet.

Switch: A network device that manages network traffic in order to minimize collisions and maximize speed.

t

TCP/IP: Transmission Control Protocol/Internet Protocol (TCP/IP) is the network communication protocol used on the Internet. The printer's built-in networking feature supports LANs that use TCP/IP.

TKIP: Temporal Key Integrity Protocol (TKIP) is an encryption method used in [WPA](#).

u

Unicast packet: A packet sent from one device on a network to another device on the network.

w

WEP: Wired Equivalent Privacy (WEP) provides security by encrypting data sent over radio waves from one wireless device to another wireless device. WEP encodes the data sent across the network making the data unintelligible to eavesdroppers. Only devices that share the same WEP settings as the printer will be able to communicate with the printer. WEP depends on encryption keys that are static and provides less security than [WPA](#).

WEP key: A WEP key, or encryption key, is a sequence of alphanumeric characters or hexadecimal digits. After creating a WEP key, you must remember it or store it in a secure location. You may not be able to retrieve the WEP key if you lose it. A WEP key is either 64 or 128 bits long. The first 24 bits of the key are provided automatically. When creating the WEP key, the person creating the key provides the remaining bits (40 bits in the case of a 64-bit key, or 104 bits in the case of a 128-bit key).

Wireless Access Point (WAP): A Wireless Access Point (WAP) is a device through which devices (for example, computers and printers) on an infrastructure wireless network communicate with one another. A WAP is also called a base station.

Wireless profile: A wireless profile is a collection of wireless network settings that applies to a particular wireless network. For example, a wireless LAN card can have one profile for a home network and another profile for an office network. When installing a device on a network, be sure to select the appropriate profile.

WPA: Wi-Fi Protected Access (WPA) provides security by encrypting data sent over radio waves from one wireless device to another wireless device and by controlling access to network resources through authentication protocols. Only devices that share the same WPA settings as the printer will be able to communicate with the printer. WPA uses encryption keys that change frequently. WPA provides better security than WEP.

5.4 Wired Ethernet networking

For setup information, click one of the following options:

- [Ethernet basics](#)
- [Installing the printer on an Ethernet network](#)

For a description of the printer's Ethernet feature, click one of the following options:

- [Ethernet lights](#)
- [Report Page button](#)
- [Network icon](#)
- [HP Report page](#)
- [Embedded Web server \(EWS\)](#)

Other information:

- [Resetting the printer to the factory defaults](#)
- [Troubleshooting](#)

- [Glossary](#)

5.4.1 Ethernet basics

The printer's built-in Ethernet feature allows you to connect the printer directly to a 10/100 Base-T Ethernet network without the aid of an external print server.

To install the printer on an Ethernet network, follow the [Ethernet installation instructions](#).

Hardware

Hubs, switches, and routers

On an Ethernet network, devices, such as computers and printers, are each connected to a network [hub](#), [switch](#), or [router](#).

Hubs, switches, and routers may look similar, but there are important differences:

- Hubs are passive. Other devices on the network plug into the hub in order to communicate with one another. A hub does not manage the network.
- A switch allows devices on a network to communicate directly with one another in a smooth and efficient manner. A switch monitors and directs network traffic in order to allow each transmission the most possible bandwidth. By monitoring network traffic, a switch minimizes collisions and maximizes speed.
- Routers primarily connect different networks (for example, connecting a home network to the Internet). Routers are active. Routers have network administration tools, such as [firewalls](#) and [DHCP](#). A router can act as a [gateway](#), while a hub and a switch cannot.

Cables

Use a CAT-5 Ethernet cable to connect the printer to an Ethernet network. Ethernet cables have an RJ-45 plug.

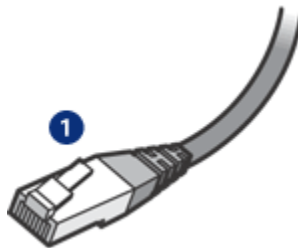

1. RJ-45 plug

Network communication

TCP/IP

Devices on a network communicate with one another using a “language” called a [protocol](#). The printer is designed to operate on networks that use a popular protocol called [TCP/IP](#).

IP address

Each device on a network identifies itself with a unique IP address. Most networks use a software tool, such as [DHCP](#) or [AutoIP](#), to automatically assign IP addresses.

Internet connections

Networks may or may not be connected to the Internet.

If you place the printer on a network connected to the Internet, it is recommended that you use a [gateway](#) so that the printer's [IP address](#) is assigned through [DHCP](#).

A gateway can either be a [router](#) or a Macintosh OSX computer running [Internet Sharing](#). For more information about Internet Sharing, see the documentation that came with the computer.

Ethernet network examples

To see some examples of Ethernet networks, see the [Ethernet network examples](#) page.

Printing

Computers on the network send print jobs directly to the printer, which prints them in the order received.

The printer can accept print jobs sent simultaneously from four users.

For example, if five users each send a print job to the printer at the same time, the printer accepts four of the print jobs and rejects the fifth. The user who sent the fifth print job should wait a few minutes and then resend the print job.

5.4.2 Ethernet network examples

These are some common Ethernet network configurations:

Shared Internet connection with a router acting as a gateway

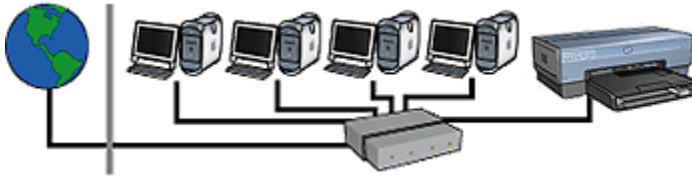

In this example, a [router](#) manages the network connections and acts as a [gateway](#) between the network and the Internet.

Shared Internet connection with a computer acting as a gateway

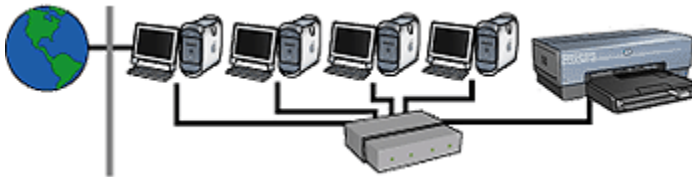

In this example, the network devices are connected to a [hub](#). A Macintosh OSX computer on the network acts as the [gateway](#) between the network and the Internet. The gateway computer uses [Internet Sharing](#) to manage the network connections and provide Internet access to the other devices.

DSL or cable Internet connection without a gateway

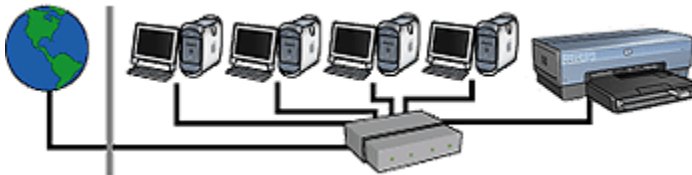

This example looks similar to the first example. However, in this example, the network devices are connected to a [hub](#), rather than a [router](#). The hub is directly connected to the Internet.



Caution: HP does not recommend this configuration. If possible, use a gateway to manage your network's Internet access in order to limit exposure to viruses and guard against unwanted entry.

Ethernet network without an Internet connection



In this example, the network devices are connected to a [hub](#). Devices use [AutoIP](#) to obtain IP addresses.

5.4.3 Installing the printer on an Ethernet network

Installing the printer on an Ethernet network is a two-part process.

First you must connect the printer to the network. Then you must install the printer software on each computer that will use the printer.

- [Connecting the printer to an Ethernet network](#)
- [Installing the printer software](#)

5.4.4 Connecting the printer to an Ethernet network

Follow these steps to connect the printer to an Ethernet network:

1. If necessary, set up the printer hardware.
For printer hardware setup instructions, see the setup poster that came with the printer.
2. Verify that the printer is powered on.
3. Connect the [Ethernet cable](#) to an available port on the network [hub](#) or [router](#).

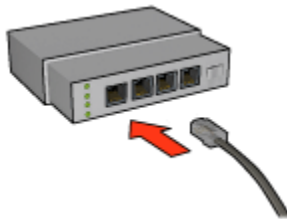



Note: Do not plug the Ethernet cable into a port labeled **WAN** or **Uplink**.

4. Connect the Ethernet cable to the Ethernet port on the back of the printer.

Note: The printer's wireless radio is disabled when a Ethernet cable is connected to the printer.

5. Do one of the following:

State of the Link light	Task
<p>On</p> 	<p>Go to step 6.</p>
<p>Off</p> 	<p>Repeat steps 2 through 4. If the lights are still off, then verify the following items:</p> <ul style="list-style-type: none"> • The printer is powered on. • The network hub or router is powered on. • All cable connections are secure. • You are using an Ethernet cable.

6. [Print an HP Report page](#).

7. Install the [printer software](#) on each computer that will use the printer.



Caution: It is recommended that the printer and the computers that use it be on the same subnet. Printer installation across subnets can be problematic depending on the type of router used.

5.4.5 Installing the printer software

Before installing the printer software on a networked computer, verify the following items:

- The printer is set up and powered on.
- The network **hub**, **switch**, or **router** is powered on and functioning properly.
- All computers on the network are powered on and connected to the network.
- The [printer is installed](#) on the network.

Software installation



For instructions on installing the printer software, see the network guide that came with the printer.

5.4.6 Ethernet lights

The printer's Ethernet lights indicate the status of the printer's Ethernet connection.

Link light

The Link light is solid when the printer is connected to an Ethernet network and powered on.

State of the Link light	State of the printer
On 	Connected to an Ethernet network and powered on. The printer's wireless radio is disabled when a Ethernet cable is connected to the printer.
Off 	Not connected to an Ethernet network or powered off.

Activity light

The Activity light flashes when the printer is receiving or transmitting data over the Ethernet connection.

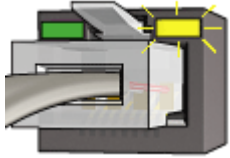
State of the Activity light	State of the printer
Flashing 	Receiving or transmitting data over the Ethernet connection.

State of the Activity light	State of the printer
<p data-bbox="199 239 236 262">Off</p>  An illustration of the printer's front panel, showing the activity light area. The light is not illuminated, indicating it is off. The printer is shown in a three-quarter view, with a sheet of paper partially inserted into the tray.	<p data-bbox="472 322 1021 378">Not receiving or transmitting data over the Ethernet connection.</p>

6 Printing photos from a computer

Select the type of photograph that you want to print:

Borderless Photos



Small borderless photo Large borderless photo Panoramic borderless photo

Photos with a white border



Small photo
with a white border

Large photo
with a white border

Panoramic photo
with a white border

Enhancing your photos

Learn how to enhance your photographs by using the printer's [photo printing features](#).

PictBridge

Use the printer [PictBridge port](#) to print photos directly from a digital camera.

6.1 Enhancing your photos

The printer software offers several features to make printing digital photos easier and improve photo quality:

- Use the [HP digital photography options](#) to touch up photos.
- Achieve the highest resolution with [Maximum dpi](#).
- Use [HP Everyday Photo Paper, Semi-gloss](#) to save money and ink when printing photos.

Learn how to add professional touches to your digital photographs:

- Use the [photo print cartridge](#) for great colors.
- Use the [color settings](#) to change how colors are printed.
- Use the [gray photo print cartridge](#) for outstanding black-and-white photos.
- Print [black-and-white photos](#).
- Print to the edges of the photo paper with [borderless printing](#).

To prevent photo paper from curling, follow the [photo paper storage guidelines](#).

6.2 HP digital photography options

The printer has several features to improve the quality of digital photographs.

Follow these steps to gain access to the **Digital Photography** panel.

1. Open the [Print](#) dialog box.
2. Select the **Digital Photography** panel.

Description

Use the **Digital Photography** panel to set these options:

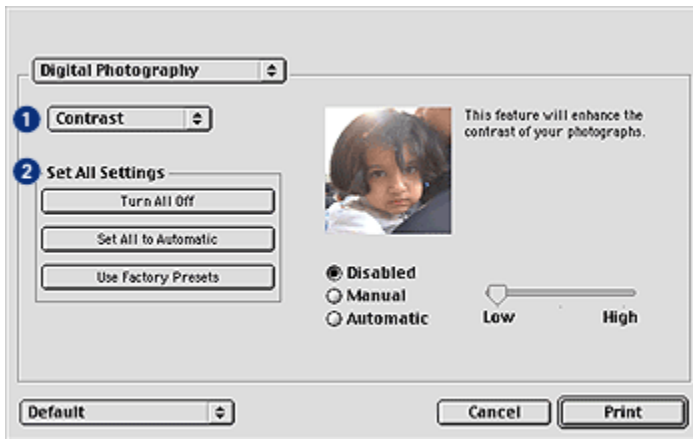

1. **Options Menu:** Select from the following options:
 - **Digital Flash:** Lighten dark images. Click **Automatic** to allow the printer driver to automatically balance lightness and darkness.
 - **Contrast enhancement:** Adjust the contrast to your preference. Click **Automatic** to allow the printer driver to automatically balance the contrast.

- **SmartFocus:** Enhance image quality and clarity. Click **On** to allow the printer driver to automatically sharpen details in the image.
 - **Smoothing:** Soften an image. Click **Automatic** to allow the printer driver to automatically set the level of smoothing for the image.
 - **Sharpness:** Adjust the image sharpness to your preference. Click **Automatic** to allow the printer driver to automatically set the level of sharpening for the image.
2. **Set All Settings Menu:** Select from the following settings options:
- **Turn All Off:** Turns off all the digital photography options.
 - **Set All to Automatic:** Sets all the digital photography options to **Automatic**.
 - **Use Factory Presets:** Sets all the digital photography options to a set of predefined print options.

6.3 Maximum dpi

The **Maximum dpi** print quality setting offers 4800 x 1200 optimized dpi printing.

The 4800 x 1200 optimized dpi print mode is the highest quality resolution for this printer. When 4800 x 1200 optimized dpi is selected in the printer driver, the tri-color print cartridge prints in the 4800 x 1200 optimized dpi mode (up to 4800 x 1200 optimized dpi color and 1200-input dpi). If a [photo print cartridge](#) is also installed, the print quality is enhanced. A photo print cartridge can be purchased separately if it is not included with your printer.

Follow these steps to print in the 4800 x 1200 optimized dpi mode:

1. Open the [Print](#) dialog box.
2. Select the **Paper Type/Quality** panel.

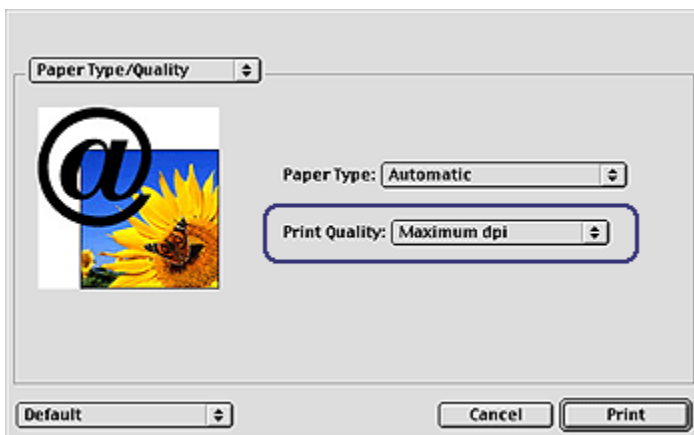

3. In the **Print Quality** drop-down list, click **Maximum dpi**.
4. Select any other print settings that you want, and then click **Print**.

6.4 Saving money when printing photos

HP Everyday Photo Paper

To save money and ink when printing photos, use **HP Everyday Photo Paper, Semi-gloss** and set the **Print quality** to **Normal**.

HP Everyday Photo Paper, Semi-gloss is designed to create quality photos with less ink.

Note: For higher-quality photos, use HP Premium Plus Photo paper and set the **Print quality** to **Best** or [Maximum dpi](#).

6.5 Photo print cartridge

The photo print cartridge, used in conjunction with the tri-color print cartridge, provides six-ink, virtually grain-free photos that have exceptional fade resistance.



The photo print cartridge can be purchased separately if it is not included with your product.

Installing the photo print cartridge

To install the photo print cartridge, remove the black print cartridge from the printer, and then install the photo print cartridge in the compartment on the right of the print cartridge cradle.

For more information, see the [print cartridge installation](#) page.

Using the photo print cartridge

Follow these steps to print in the six-ink color print mode:

1. Open the [Print](#) dialog box.

2. Select the **Paper Type/Quality** panel.
3. Click the appropriate photo paper type in the **Paper Type** drop-down list.
4. Click one of the following print-quality modes in the **Print Quality** drop-down list.
 - **Normal**
 - **Best**
 - **Maximum dpi**
5. Select any other print settings that you want, and then click **Print**.

Storing the photo print cartridge

To maintain the health of the print cartridge, follow the [print cartridge storage guidelines](#).

6.6 Using color settings

Use the **Color** panel to adjust how printed colors appear on your printout.

Adjusting these settings causes the printed colors to differ from the colors that appear on your computer monitor.

Follow these steps to specify color settings:

1. Open the **Print** dialog box.
2. Select the **Color** panel.



3. Verify that **ColorSmart/sRGB** is selected in the **Image** drop-down list.
4. Adjust the **Saturation**, **Brightness**, and **Color tone** to affect how overall colors are printed.

5. Select any other print settings that you want, and then click **Print**.

6.7 Gray photo print cartridge

The gray photo print cartridge, used in conjunction with the tri-color print cartridge, prints high-quality black-and-white photographs.



The gray photo print cartridge can be purchased separately if it is not included with your product.

Installing the gray photo print cartridge

To install the gray photo print cartridge, remove the black print cartridge from the printer, and then install the gray photo print cartridge in the compartment on the right of the print cartridge cradle.

For more information, see the [print cartridge installation](#) page.

Using the gray photo print cartridge

To use the gray photo print cartridge, follow the [steps to print a black-and-white photo](#).

Storing the gray photo print cartridge

To maintain the health of the print cartridge, follow the [print cartridge storage guidelines](#).

6.8 Printing black-and-white photos

You can perform the following tasks with the printer:

- [Print a black-and-white photo](#)
- [Print a color photo in black-and-white](#)

For great black-and-white photos, install a [gray photo print cartridge](#) and a tri-color printer cartridge in the printer.

Printing a black-and-white photo

To print a photo that is already black-and-white, simply follow the instructions for the [type and size of photo](#) that you want to print.

Printing a color photo in black and white

Follow these steps to print a color photo in black-and-white:

1. Open the [Print](#) dialog box.
2. Select the **Color** panel.

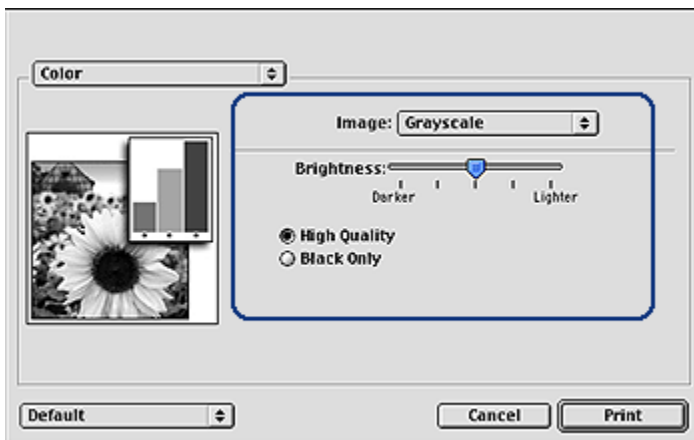

3. In the **Image** drop-down list, click **Grayscale**.
4. Click **High Quality**.
5. Select any other print settings that you want, and then click **Print**.

6.9 Printing borderless photos

Use borderless printing to print to the edges of certain paper types and on a range of standard paper sizes.

Guidelines

- Do not print borderless documents in [ink-backup mode](#). Always have two print cartridges installed in the printer.
- Open the file in a software application and assign the image size. Ensure that the size corresponds to the paper size on which you want to print the image.

Printing

Follow these steps to print a borderless document:

1. Open the file that you want to print.
2. Open the [Page Setup](#) dialog box.

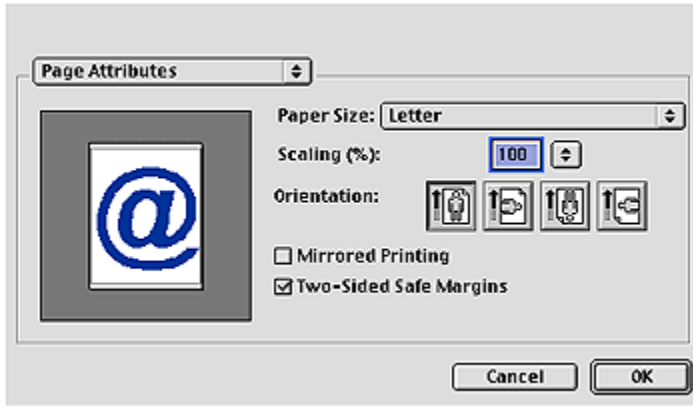

3. Click the appropriate borderless paper size in the **Paper Size** list.
4. Click **OK**.
5. Open the [Print](#) dialog box.
6. Select any other print settings that you want, and then click **Print**.

If you printed on photo paper that has a tear-off tab, remove the tab to make the document completely borderless.



6.10 Storing and handling photo paper

Follow these instructions to maintain the quality of your HP brand photo paper.

Storage

- Keep unused photo paper in a resealable plastic bag, in the box in which it was originally packaged. Store the packaged photo paper on a flat surface in a cool place.
- When you are ready to print, remove only the paper that you plan to use immediately from the plastic bag. When you have finished printing, return any unused photo paper to the plastic bag.
- Do not leave unused photo paper in the printer paper tray. The paper might start to curl, which can reduce the quality of your photographs.

Handling

- Always hold photo paper by its edges. Fingerprints on photo paper can reduce print quality.
- Verify that the photo paper is not curled. If the photo paper is curled, place the paper in a plastic bag and gently bend it the opposite direction of the curl until the paper lies flat. If the problem persists, use photo paper that is not curled.

6.11 Small borderless photos

Guidelines

- For high-quality results, use a [photo print cartridge](#) in combination with the tri-color print cartridge.
- For maximum fade resistance, use HP Premium Plus Photo Paper and install a photo print cartridge in the printer.
- To learn how to use the photo printing features, see the [photo enhancing](#) page.
- Use [HP Everyday Photo Paper, Semi-gloss](#) to save money and ink when printing photos.
- Verify that the photo paper that you are using is flat. For information about preventing photo paper from curling, see the [photo paper storage instructions](#).
- Do not exceed the In-tray capacity: up to 25 sheets.

Preparing to print

To print a single photo, use the [photo/envelope feeder](#).

To print multiple photos, follow these steps:

1. Verify that the printer is turned on.
2. Remove the Out tray, and then remove all of the paper from the In tray.
3. Slide the paper-width guide all the way to the left, and then pull out the paper-length guide.

4. Verify that the photo paper is flat.

If the photo paper is not flat, see the [photo paper storage instructions](#).

5. Place the photo paper in the In tray with the side to be printed on facing down.
If you are using a photo paper that has a tear-off tab, verify that the tab is pointing away from the printer.

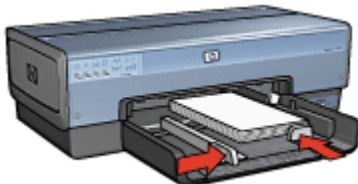

6. Slide the paper guides firmly against the paper.
7. Replace the Out tray.

Printing

1. Open the [Page Setup](#) dialog box, and then select the following settings:
 - **Paper Size:** The appropriate borderless paper size
 - **Orientation:** The appropriate orientation
2. Click **OK**.
3. Open the [Print](#) dialog box.
4. Select the **General** panel, and in the **Paper Source** drop-down list, click **Upper Tray**.
5. Select the **Paper Type/Quality** panel, and then select the following settings:
 - **Paper Type:** Click **Photo paper**, and then click the appropriate photo paper type
 - **Print Quality:** **Best** or **Maximum dpi**
6. If you want to use them, set the [HP digital photography options](#).
7. Select any other print settings that you want, and then click **Print**.

6.12 Large borderless photos

Guidelines

- For high-quality results, use a [photo print cartridge](#) in combination with the tri-color print cartridge.

- For maximum fade resistance, use HP Premium Plus Photo Paper and install a photo print cartridge in the printer.
- To learn how to use the photo printing features, see the [photo enhancing](#) page.
- Use [HP Everyday Photo Paper, Semi-gloss](#) to save money and ink when printing photos.
- Verify that the photo paper that you are using is flat. For information about preventing photo paper from curling, see the [photo paper storage instructions](#).
- Do not exceed the In-tray capacity: up to 25 sheets.

Preparing to print

1. Verify that the printer is turned on.
2. Raise the Out tray, and then remove all of the paper from the In tray.
3. Slide the paper-width guide all the way to the left, and then pull out the paper-length guide.
4. Verify that the photo paper is flat.
If the photo paper is not flat, see the [photo paper storage instructions](#).
5. Place the photo paper in the In tray with the side to be printed on facing down.

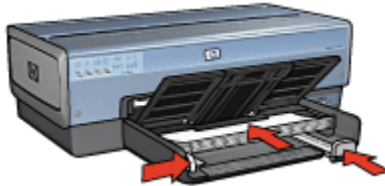

6. Slide the paper guides firmly against the paper.
7. Lower the Out tray.

Printing

1. Open the [Page Setup](#) dialog box, and then select the following settings:
 - **Paper Size:** The appropriate borderless paper size
 - **Orientation:** The appropriate orientation
2. Click **OK**.
3. Open the [Print](#) dialog box.
4. Select the **General** panel, and in the **Paper Source** drop-down list, click **Upper Tray**.
5. Select the **Paper Type/Quality** panel, and then select the following settings:

- **Paper Type:** Click **Photo paper**, and then click the appropriate photo paper type
 - **Print Quality:** **Best** or **Maximum dpi**
6. If you want to use them, set the [HP digital photography options](#).
 7. Select any other print settings that you want, and then click **Print**.

6.13 Panoramic borderless photos

Guidelines

- For high-quality results, use a [photo print cartridge](#) in combination with the tri-color print cartridge.
- For maximum fade resistance, use HP Premium Plus Photo Paper and install a photo print cartridge in the printer.
- To learn how to use the photo printing features, see the [photo enhancing](#) page.
- Use [HP Everyday Photo Paper, Semi-gloss](#) to save money and ink when printing photos.
- Verify that the photo paper that you are using is flat. For information about preventing photo paper from curling, see the [photo paper storage instructions](#).
- Do not exceed the In-tray capacity: up to 25 sheets.

Preparing to print

1. Verify that the printer is turned on.
2. Raise the Out tray, and then remove all of the paper from the In tray.
3. Slide the paper-width guide all the way to the left, and then pull out the paper-length guide.
4. Verify that the photo paper is flat.

If the photo paper is not flat, see the [photo paper storage instructions](#).

5. Place the photo paper in the In tray with the side to be printed on facing down.

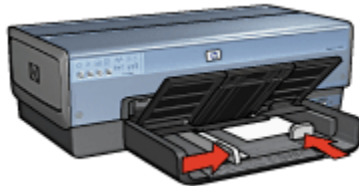

6. Slide the paper guides firmly against the paper.

Note: Some panoramic paper sizes may extend beyond the edge of the In tray. When printing on such papers, be sure to slide the paper width-guide firmly against the edge of the paper.

7. Lower the Out tray.

Printing

1. Open the [Page Setup](#) dialog box, and then select the following settings:
 - **Paper Size:** The appropriate borderless paper size
 - **Orientation:** The appropriate orientation
2. Click **OK**.
3. Open the [Print](#) dialog box.
4. Select the **General** panel, and in the **Paper Source** drop-down list, click **Upper Tray**.
5. Select the **Paper Type/Quality** panel, and then select the following settings:
 - **Paper Type:** Click **Photo paper**, and then click the appropriate photo paper type
 - **Print Quality:** **Best** or **Maximum dpi**
6. If you want to use them, set the [HP digital photography options](#).
7. Select any other print settings that you want, and then click **Print**.

6.14 Small photos with a white border

Guidelines

- For high-quality results, use a [photo print cartridge](#) in combination with the tri-color print cartridge.
- For maximum fade resistance, use HP Premium Plus Photo Paper and install a photo print cartridge in the printer.
- To learn how to use the photo printing features, see the [photo enhancing](#) page.
- Use [HP Everyday Photo Paper, Semi-gloss](#) to save money and ink when printing photos.
- Verify that the photo paper that you are using is flat. For information about preventing photo paper from curling, see the [photo paper storage instructions](#).
- Do not exceed the In-tray capacity: up to 25 sheets.

Preparing to print

To print a single photo, use the [photo/envelope feeder](#).

To print multiple photos, follow these steps:

1. Verify that the printer is turned on.
2. Remove the Out tray, and then remove all of the paper from the In tray.
3. Slide the paper-width guide all the way to the left, and then pull out the paper-length guide.
4. Verify that the photo paper is flat.

If the photo paper is not flat, see the [photo paper storage instructions](#).

5. Place the photo paper in the In tray with the side to be printed on facing down. If you are using a photo paper that has a tear-off tab, verify that the tab is pointing away from the printer.

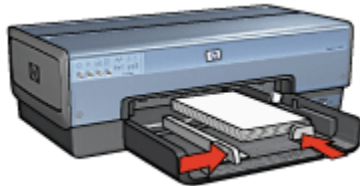

6. Slide the paper guides firmly against the paper.
7. Replace the Out tray.

Printing

1. Open the [Page Setup](#) dialog box, and then select the following settings:
 - **Paper Size:** The appropriate paper size
 - **Orientation:** The appropriate orientation
2. Click **OK**.
3. Open the [Print](#) dialog box.
4. Select the **General** panel, and in the **Paper Source** drop-down list, click **Upper Tray**.
5. Select the **Paper Type/Quality** panel, and then select the following settings:
 - **Paper Type:** Click **Photo paper**, and then click the appropriate photo paper type
 - **Print Quality:** **Best** or **Maximum dpi**
6. If you want to use them, set the [HP digital photography options](#).
7. Select any other print settings that you want, and then click **Print**.

6.15 Large photos with a white border

Guidelines

- For high-quality results, use a [photo print cartridge](#) in combination with the tri-color print cartridge.
- For maximum fade resistance, use HP Premium Plus Photo Paper and install a photo print cartridge in the printer.
- To learn how to use the photo printing features, see the [photo enhancing](#) page.
- Use [HP Everyday Photo Paper, Semi-gloss](#) to save money and ink when printing photos.
- Verify that the photo paper that you are using is flat. For information about preventing photo paper from curling, see the [photo paper storage instructions](#).
- Do not exceed the In-tray capacity: up to 25 sheets.

Preparing to print

1. Verify that the printer is turned on.
2. Raise the Out tray, and then remove all of the paper from the In tray.
3. Slide the paper-width guide all the way to the left, and then pull out the paper-length guide.
4. Verify that the photo paper is flat.
If the photo paper is not flat, see the [photo paper storage instructions](#).
5. Place the photo paper in the In tray with the side to be printed on facing down.

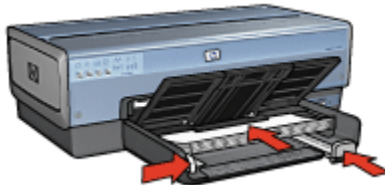

6. Slide the paper guides firmly against the paper.
7. Lower the Out tray.

Printing

1. Open the [Page Setup](#) dialog box, and then select the following settings:
 - **Paper Size:** The appropriate paper size
 - **Orientation:** The appropriate orientation
2. Click **OK**.

3. Open the [Print](#) dialog box.
4. Select the **General** panel, and in the **Paper Source** drop-down list, click **Upper Tray**.
5. Select the **Paper Type/Quality** panel, and then select the following settings:
 - **Paper Type:** Click **Photo paper**, and then click the appropriate photo paper type
 - **Print Quality:** **Best** or **Maximum dpi**
6. If you want to use them, set the [HP digital photography options](#).
7. Select any other print settings that you want, and then click **Print**.

6.16 Panoramic photos with a white border

Guidelines

- For high-quality results, use a [photo print cartridge](#) in combination with the tri-color print cartridge.
- For maximum fade resistance, use HP Premium Plus Photo Paper and install a photo print cartridge in the printer.
- To learn how to use the photo printing features, see the [photo enhancing](#) page.
- Use [HP Everyday Photo Paper, Semi-gloss](#) to save money and ink when printing photos.
- Verify that the photo paper that you are using is flat. For information about preventing photo paper from curling, see the [photo paper storage instructions](#).
- Do not exceed the In-tray capacity: up to 25 sheets.

Preparing to print

1. Verify that the printer is turned on.
2. Raise the Out tray, and then remove all of the paper from the In tray.
3. Slide the paper-width guide all the way to the left, and then pull out the paper-length guide.
4. Verify that the photo paper is flat.
If the photo paper is not flat, see the [photo paper storage instructions](#).
5. Place the photo paper in the In tray with the side to be printed on facing down.

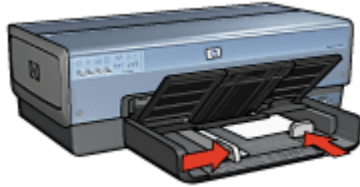

6. Slide the paper guides firmly against the paper.

Note: Some panoramic paper sizes may extend beyond the edge of the In tray. When printing on such papers, be sure to slide the paper width-guide firmly against the edge of the paper.

7. Lower the Out tray.

Printing

1. Open the [Page Setup](#) dialog box, and then select the following settings:
 - **Paper Size:** The appropriate paper size
 - **Orientation:** The appropriate orientation
2. Click **OK**.
3. Open the [Print](#) dialog box.
4. Select the **General** panel, and in the **Paper Source** drop-down list, click **Upper Tray**.
5. Select the **Paper Type/Quality** panel, and then select the following settings:
 - **Paper Type:** Click **Photo paper**, and then click the appropriate photo paper type
 - **Print Quality:** **Best** or **Maximum dpi**
6. If you want to use them, set the [HP digital photography options](#).
7. Select any other print settings that you want, and then click **Print**.

7 Printing other documents



E-mail



Letters



Documents



Envelopes



Postcards



Brochures



Greeting cards



Transparencies



Labels



Index cards



Booklets



Posters



Banners



Iron-on
transfers

Printing tips

Minimize your cost and effort while maximizing the quality of your printouts by using these [printing tips](#).

Printer software

Learn about the [printer software](#).

7.1 Email

Guidelines

Do not exceed the In-tray capacity: up to 150 sheets.

Preparing to print

1. Verify that the printer is turned on.
2. Raise the Out tray.
3. Slide the paper-width guide all the way to the left, and then pull out the paper-length guide.
4. Place plain paper in the In tray, pushing the paper into the printer until it stops.
5. Slide the paper guides firmly against the paper.

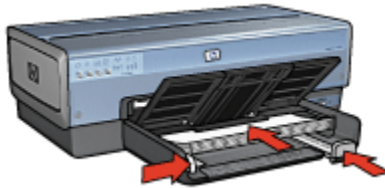

6. Lower the Out tray.

Printing

1. If necessary, open the [Page Setup](#) dialog box and set the paper size, scaling, or orientation options.
2. Open the [Print](#) dialog box.
3. Select the **Paper Type/Quality** panel.
4. In the **Paper Type** drop-down list, click **Automatic** or **Plain paper**.
5. Select the following print settings as appropriate:
 - [Print quality](#)
 - [Paper source](#)
6. Select any other print settings that you want, and then click **Print**.

7.2 Letters

Guidelines

- For help printing on an envelope, see the [envelope](#) page.

- Do not exceed the In-tray capacity: up to 150 sheets.

Preparing to print

1. Verify that the printer is turned on.
2. Raise the Out tray.
3. Slide the paper-width guide all the way to the left, then pull out the paper-length guide.
4. Place plain paper in the In tray, pushing the paper into the printer until it stops.
5. Slide the paper guides firmly against the paper.

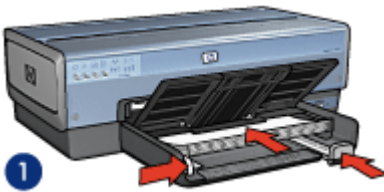

1. Letter or A4 paper

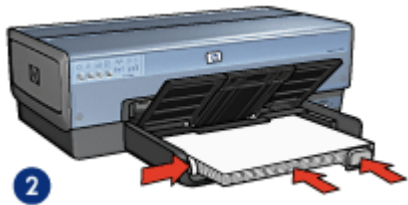

2. Legal paper

Note: If you are using letterhead, verify that the letterhead is facing down and towards the interior of the printer.

6. Lower the Out tray.

Do not extend the Out-tray extension stop when printing on legal paper.

Printing

1. If necessary, open the [Page Setup](#) dialog box and set the paper size, scaling, or orientation options.
2. Open the [Print](#) dialog box.
3. Select the **Paper Type/Quality** panel.
4. In the **Paper Type** drop-down list, click **Automatic** or **Plain paper**.
5. Select the following print settings as appropriate:
 - [Print quality](#)
 - [Paper source](#)
6. Select any other print settings that you want, and then click **Print**.

7.3 Documents

Guidelines

- Save paper with [two-sided printing](#).
- Do not exceed the In-tray capacity: up to 150 sheets.

Preparing to print

1. Verify that the printer is turned on.
2. Raise the Out tray.
3. Slide the paper-width guide all the way to the left, then pull out the paper-length guide.
4. Place plain paper in the In tray, pushing the paper into the printer until it stops.
5. Slide the paper guides firmly against the paper.

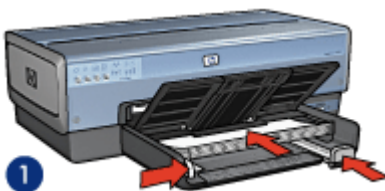

1. Letter or A4 paper

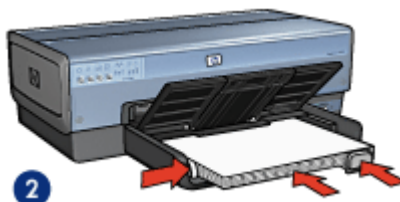

2. Legal paper

6. Lower the Out tray.

Do not extend the Out-tray extension stop when printing on legal paper.

Printing

1. If necessary, open the [Page Setup](#) dialog box and set the paper size, scaling, or orientation options.
2. Open the [Print](#) dialog box.
3. Select the **Paper Type/Quality** panel.
4. In the **Paper Type** drop-down list, click **Automatic** or **Plain paper**.
5. Select the following print settings as appropriate:
 - [Print quality](#)
 - [Paper source](#)
 - [Two-sided printing](#)

6. Select any other print settings that you want, and then click **Print**.

7.4 Envelopes

Guidelines

- Avoid using envelopes that have the following qualities:
 - Have clasps or windows
 - Have thick, irregular, or curled edges
 - Are shiny or embossed
 - Are wrinkled, torn, or otherwise damaged
- Align the envelope edges before inserting them in the In tray.
- Do not exceed the In-tray capacity: up to 20 envelopes.

Preparing to print

If you are printing on a single envelope, use the [photo/envelope feeder](#).

If you are printing on multiple envelopes, follow these steps:

1. Verify that the printer is turned on.
2. Remove the Out tray, and then remove all paper from the In tray.
3. Slide the paper-width guide all the way to the left, and then pull out the paper-length guide.
4. Place the envelopes, with the sides to be printed on facing down and the flaps to the left, into the In tray and to the right. Push the envelopes into the printer until they stop.

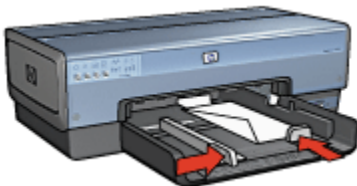

5. Slide the paper guides firmly against the envelopes.
6. Replace the Out tray.

Printing

1. If necessary, open the [Page Setup](#) dialog box and set the paper size, scaling, or orientation options.

2. Open the [Print](#) dialog box.
3. Select the **Paper Type/Quality** panel.
4. In the **Paper Type** drop-down list, click **Automatic** or **Plain paper**.
5. Select any other print settings that you want, and then click **Print**.

7.5 Postcards



If the optional Auto Two-Sided Print Accessory with Small Paper Tray is attached to the printer, follow the [steps for printing postcards with the Auto Two-Sided Print Accessory with Small Paper Tray](#).

Guidelines

- Use only cards and small media that meet the printer paper-size specifications. For specifications, see the reference guide that came with the printer.
- Do not exceed the In-tray capacity: up to 60 cards.

Preparing to print

To print a single card, use the [photo/envelope feeder](#).

To print multiple cards, follow these steps:

1. Verify that the printer is turned on.
2. Remove the Out tray, then remove all paper from the In tray.
3. Slide the paper-width guide all the way to the left, then pull out the paper-length guide.
4. Place the cards, with the sides to be printed on facing down and one of the short sides pointing towards the printer, into In tray and to the right. Push the cards into the printer until they stop.

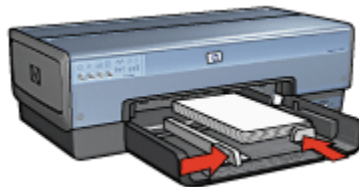

5. Slide the paper guides firmly against the cards.

6. Replace the Out tray.

Printing

1. Open the **Page Setup** dialog box, and then select the following settings:
 - **Paper Size:** The appropriate paper size

Note: To print a borderless card, click the borderless photo size that matches the card size.

 - **Orientation:** The appropriate orientation
2. Click **OK**.
3. Open the **Print** dialog box.
4. Select the **General** panel, and in the **Paper Source** drop-down list, click **Upper Tray**.
5. Select the **Paper Type/Quality** panel, and then select the following settings:
 - **Paper Type:** The appropriate paper type
 - **Print Quality:** **Normal**, **Best**, or **Maximum dpi**
6. If you want to use them, set the **HP digital photography options**.
7. Select any other print settings that you want, and then click **Print**.

Note: If an out-of-paper message appears, verify that the cards are positioned correctly in the paper tray.

7.6 Brochures

Guidelines

- Learn to print **borderless brochures**.
- For great results, use HP Brochure & Flyer Paper.
- Do not exceed the In-tray capacity: up to 25 sheets.

Preparing to print

1. Verify that the printer is turned on.
2. Raise the Out tray.
3. Slide the paper-width guide all the way to the left, then pull out the paper-length guide.
4. Place brochure paper in the In tray, pushing the paper into the printer until it stops.

5. Slide the paper guides firmly against the paper.

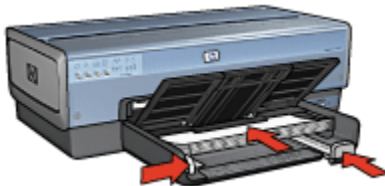

6. Lower the Out tray.

Printing

1. If necessary, open the [Page Setup](#) dialog box and set the paper size, scaling, or orientation options.
2. Open the [Print](#) dialog box.
3. Select the **General** panel, and in the **Paper Source** drop-down list, click **Upper tray**.
4. Select the **Paper Type/Quality** panel, and then specify the following settings:
 - **Paper Type:** The appropriate brochure paper type
 - **Print Quality:** **Normal**, **Best**, or **Maximum dpi**
5. Select any other print settings that you want, and then click **Print**.

7.7 Greeting cards

Guidelines

- Unfold prefolded cards, and then place them in the In tray.
- For great results, use HP Greeting Card Paper.
- Do not exceed the In-tray capacity: up to 30 cards.

Preparing to print

1. Verify that the printer is turned on.
2. Raise the Out tray, then remove all paper from the In tray.
3. Slide the paper-width guide all the way to the left, then pull out the paper-length guide.
4. Fan the edges of the greeting cards to separate them, then align the edges.
5. Place the greeting cards in the In tray, with the side to be printed on facing down. Push the cards into the printer until they stop.

6. Slide the paper guides firmly against the paper.

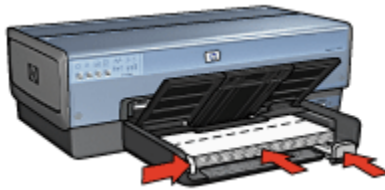

7. Lower the Out tray.

Printing

1. If necessary, open the **Page Setup** dialog box and set the paper size, scaling, or orientation options.
2. Open the **Print** dialog box.
3. Select the **General** panel, and in the **Paper Source** drop-down list, click **Upper tray**.
4. Select the **Paper Type/Quality** panel, and then specify the following settings:
 - **Paper Type:** The appropriate greeting card paper type
 - **Print Quality:** **Normal**, **Best**, or **Maximum dpi**
5. Select any other print settings that you want, and then click **Print**.

7.8 Transparencies

Guidelines

- For great results, use HP Premium Inkjet Transparency Film.
- Do not exceed the In-tray capacity: up to 30 transparencies.

Preparing to print

1. Verify that the printer is turned on.
2. Raise the Out tray, and then remove all paper from the In tray.
3. Slide the paper-width guide all the way to the left, then pull out the paper-length guide.
4. Place the transparencies in the In tray, with the side to printed on facing down and the adhesive strip facing up and toward the printer.

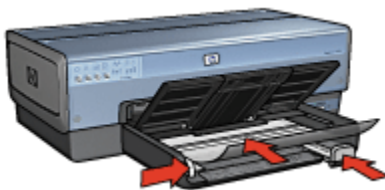

5. Carefully push the transparencies into the printer until they stop so that none of the adhesive strips catch on one another.
6. Slide the paper guides firmly against the paper.
7. Lower the Out tray.

Printing

1. If necessary, open the [Page Setup](#) dialog box and set the paper size, scaling, or orientation options.
2. Open the [Print](#) dialog box.
3. Select the **General** panel, and in the **Paper Source** drop-down list, click **Upper tray**.
4. Select the **Paper Type/Quality** panel, and then specify the following settings:
 - **Paper Type:** The appropriate transparency film type
 - **Print Quality:** **Normal** or **Best**
5. Select any other print settings that you want, and then click **Print**.

7.9 Labels

Guidelines

- Use only labels that are designed specifically for inkjet printers.
- Use only full sheets of labels.
- Verify that the labels are not sticky, wrinkled, or pulling away from the protective backing.
- Do not exceed the In-tray capacity: up to 30 sheets of labels (use only letter-size or A4-size sheets).

Preparing to print

1. Verify that the printer is turned on.
2. Raise the Out tray, and then remove all paper from the In tray.

3. Slide the paper-width guide all the way to the left, and then pull out the paper-length guide.
4. Fan the edges of the label sheets to separate them, and then align the edges.
5. Place the label sheets in the In tray with the label side facing down. Push the sheets into the printer until they stop.

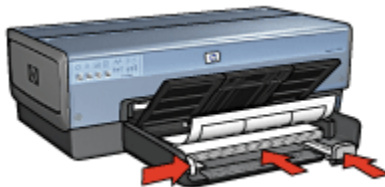

6. Slide the paper guides firmly against the edge of the sheets.
7. Lower the Out tray.

Printing

1. Open the [Page Setup](#) dialog box, and then select the following settings:
 - **Paper Size:** **A4** or **US Letter**
 - **Orientation:** The appropriate orientation
2. Click **OK**.
3. Open the [Print](#) dialog box.
4. Select the **General** panel, and in the **Paper Source** drop-down list, click **Upper tray**.
5. Select the **Paper Type/Quality** panel.
6. In the **Paper Type** drop-down list, click **Automatic** or **Plain paper**.
7. Select any other print settings that you want, and then click **Print**.

7.10 Index cards and other small media

Guidelines

- Use only cards and small media that meet the printer paper-size specifications. For specifications, see the reference guide that came with the printer.
- Do not exceed the In-tray capacity: up to 60 cards.

Preparing to print

To print a single card, use the [photo/envelope feeder](#).

To print multiple cards, follow these steps:

1. Verify that the printer is turned on.
2. Remove the Out tray, then remove all paper from the In tray.
3. Slide the paper-width guide all the way to the left, then pull out the paper-length guide.
4. Place the cards, with the sides to be printed on facing down and one of the short sides pointing towards the printer, into In tray and to the right. Push the cards into the printer until they stop.

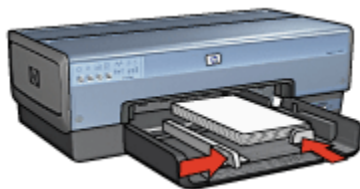

5. Slide the paper guides firmly against the cards.
6. Replace the Out tray.

Printing

1. Open the [Page Setup](#) dialog box, and then select the following settings:
 - **Paper Size:** The appropriate paper size

Note: To print a borderless card, click the borderless photo size that matches the card size.

 - **Orientation:** The appropriate orientation
2. Click **OK**.
3. Open the [Print](#) dialog box.
4. Select the **General** panel, and in the **Paper Source** drop-down list, click **Upper Tray**.
5. Select the **Paper Type/Quality** panel, and then select the following settings:
 - **Paper Type:** The appropriate paper type
 - **Print Quality:** **Normal**, **Best**, or **Maximum dpi**
6. If you want to use them, set the [HP digital photography options](#).
7. Select any other print settings that you want, and then click **Print**.

Note: If an out-of-paper message appears, verify that the cards are positioned correctly in the paper tray.

7.11 Booklets

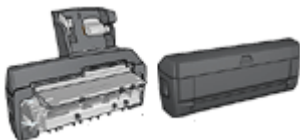

If an optional two-sided printing accessory is attached to the printer, then follow the [steps to print a booklet automatically](#).

Booklet printing automatically arranges and resizes the pages of a document so that when the pages are folded into a booklet, the page order is correct.

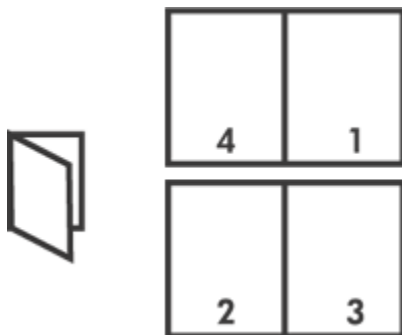

Guidelines

Do not exceed the In-tray capacity: up to 150 sheets.

Preparing to print

1. Verify that the printer is turned on.
2. Raise the Out tray.
3. Slide the paper-width guide all the way to the left, and then pull out the paper-length guide.
4. Place plain paper in the In tray, pushing the paper into the printer until it stops.
5. Slide the paper guides firmly against the paper.

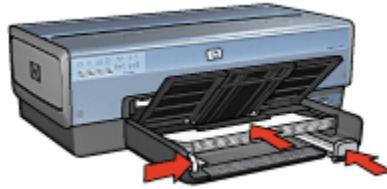

6. Lower the Out tray.

Printing

To print a booklet, follow these steps:

1. Open the **Print** dialog box.
2. Select the **Layout** panel.

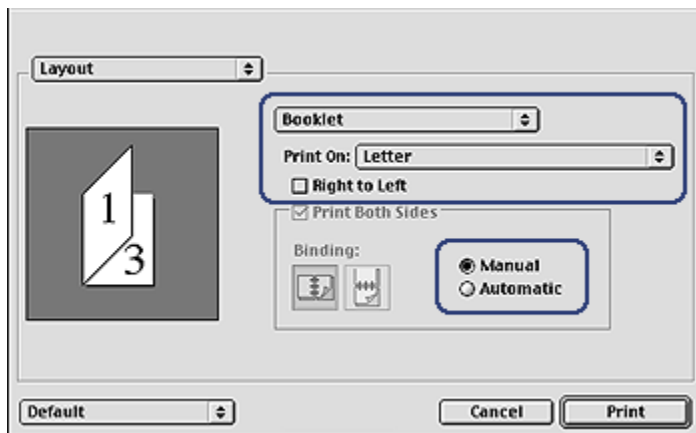

3. In the menu, click **Booklet**.
4. In the **Print On** drop-down list, click the appropriate paper size.
5. If you want the pages to be ordered from right to left, select the **Right to Left** check box.

Note: For most languages, leave the **Right to Left** check box clear.

6. Select any other printer setting that you want, and then click **Print**.
7. When prompted, reload the printed pages in the In tray as shown below.

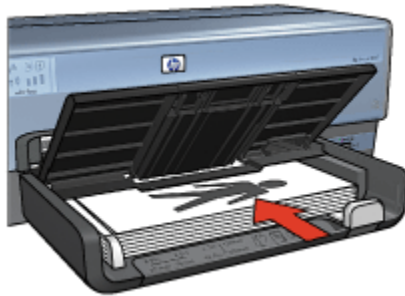

8. Click **Continue** to finish printing the booklet.

7.12 Posters

Guidelines

- After the sections of a poster have been printed, trim the edges of the sheets, and then tape the sheets together.



- Do not exceed the In-tray capacity: up to 150 sheets.

Preparing to print

1. Verify that the printer is turned on.
2. Raise the Out tray.
3. Slide the paper-width guide all the way to the left, and then pull out the paper-length guide.
4. Place plain paper in the In tray, pushing the paper into the printer until it stops.
5. Slide the paper guides firmly against the paper.

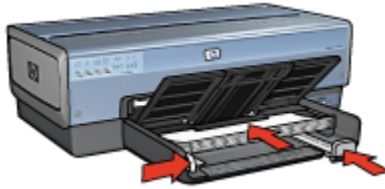

6. Lower the Out tray.

Printing

1. If necessary, open the [Page Setup](#) dialog box and set the paper size, scaling, or orientation options.
2. Open the [Print](#) dialog box.
3. Select the **Paper Type/Quality** panel.
4. In the **Paper Type** drop-down list, click **Automatic** or **Plain paper**.
5. Select the **Layout** panel, and then select the following options:
 - **Multiple Pages Per Sheet Menu: Tiling**
 - **Tiling Size: 2x2, 3x3, or 4x4**
6. Select any other print settings that you want, and then click **Print**.

7.13 Banners

Guidelines

- Use HP Banner Paper for great results.
- Remove any perforated strips from the banner paper before loading it in the In tray.

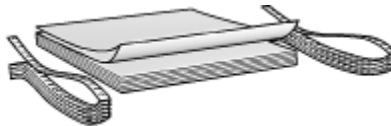

- Do not exceed the In-tray capacity: up to 20 sheets.

Preparing to print

1. Verify that the printer is turned on.
2. Remove the Out tray, and then remove all paper from the In tray.

3. Slide the paper width-guide all the way to the left, and then pull out the paper-length guide.
4. Place the banner paper in the In tray so that the unattached edge is on top of the paper stack and pointing toward the printer.

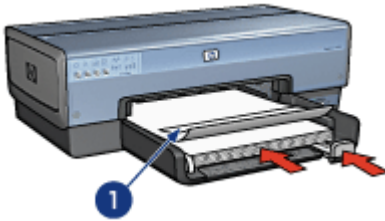

1. Unattached edge

5. Slide the paper-width guide firmly against the paper.

Note: Leave the Out tray off of the printer when printing a banner.

Printing

1. Open the [Page Setup](#) dialog box.
2. In the **Paper Size** drop-down list, click **A4 Banner** or **US Letter Banner**.
3. Click **OK**.
4. Open the [Print](#) dialog box.
5. Select the **General** panel, and in the **Paper Source** drop-down list, click **Upper tray**.
6. Select the **Paper Type/Quality** panel.
7. In the **Paper Type** drop-down list, click **Automatic** or **Plain paper**.
8. Select any other print settings that you want, and then click **Print**.

7.14 Iron-on transfers

Guidelines

- Use HP Iron-on Transfers for great results.
- When printing a mirror image, the text and the pictures are horizontally reversed from what appears on the computer screen.



- Do not exceed the In tray capacity: Up to 20 sheets.

Preparing to print

1. Verify that the printer is turned on.
2. Raise the Out tray.
3. Slide the paper-width guide all the way to the left, and then pull out the paper-length guide.
4. Place iron-on transfer paper with the side to be printed on facing down in the In tray.
5. Push the paper into the printer until it stops.
6. Slide the paper guides firmly against the paper.

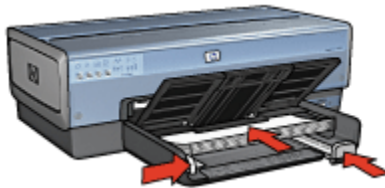

7. Lower the Out tray.

Printing

1. Open the [Page Setup](#) dialog box, and then select the following settings:

Note: Some iron-on transfer paper types do not require you to print a mirror image. Consult the instructions that came with your iron-on transfer paper to see if printing a mirror image is required.

- **Paper Size:** **A4** or **US Letter**
 - **Mirror Image:** Selected
2. Click **OK**.
 3. Open the [Print](#) dialog box.
 4. Select the **General** panel, and in the **Paper Source** drop-down list, click **Upper tray**.

5. Select the **Paper Type/Quality** panel.
6. In the **Paper Type** drop-down list, click **Automatic** or the appropriate iron-on transfer paper type.
7. Select any other print settings that you want, and then click **Print**.

8 Printing tips

Save time

- Use the [250-Sheet Plain Paper Tray Accessory](#) to reload the printer less often.
- Print from [front to back](#).
- Print [collated copies](#).

Save money

- Print a two-sided document either [automatically](#) or [manually](#).
- Print [multiple pages on a single sheet of paper](#).

Enhance the quality of printouts

- Select the right [paper type](#).
- Select the right [print quality](#).
- [Resize](#) the document as needed.
- Print a [borderless brochure](#).

8.1 Using the 250-Sheet Plain Paper Tray Accessory

If the 250-Sheet Plain Paper Tray Accessory is not installed on the printer, follow the [installation steps](#).

Note: The 250-Sheet Plain Paper Tray Accessory is not available in all countries/regions.

Follow these steps to use the 250-Sheet Plain Paper Tray Accessory:

1. Open the [Print](#) dialog box.

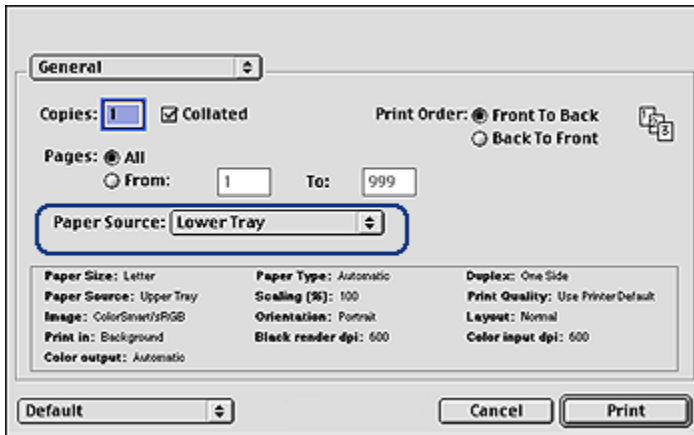

2. On the **General** panel, click one of the following options in the **Paper Source** drop-down list:
 - **Lower tray:** Prints from the 250-Sheet Plain Paper Tray Accessory.
 - **Upper, then lower:** Prints from the In tray. If the In tray is empty, then the printer prints from the 250-Sheet Plain Paper Tray Accessory.
 - **Lower, then upper:** Prints from the 250-Sheet Plain Paper Tray Accessory. If the accessory is empty, then the printer prints from the In tray.

8.2 Setting the print order

Setting the print order determines the order in which your document will be printed. Frequently, it is convenient to have the first page of a document printed last so that the complete document is lying face-up in the Out tray.

Follow these steps to set the print order:

1. Open the [Print](#) dialog box.
2. Select the **General** panel.

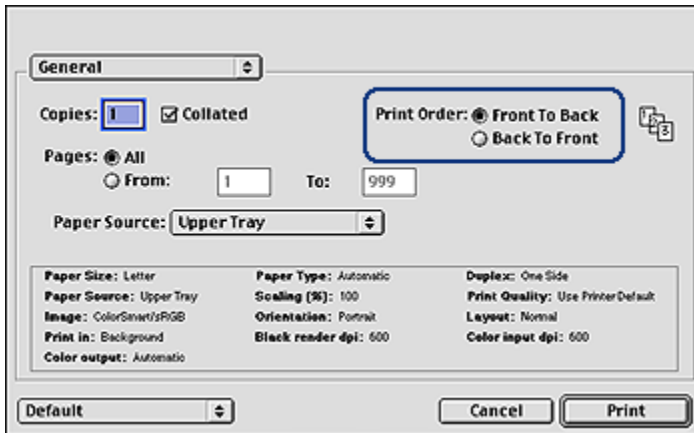

3. Select one of the following options for the **Print Order**:
 - **Front to back**: Prints the first page of the document first.
 - **Back to front**: Prints the first page of the document last. This is the appropriate setting for most print jobs.
4. Select any other print settings that you want, and then click **Print**.

8.3 Printing collated copies

If you are printing several copies of a document at one time, use collation so that you do not have to re-arrange the copies after printing.

Note: Some software programs do not allow you to use the printer software to specify the number of copies to print. If the program that you are using allows you to specify the number of copies to print, then specify the number of copies to print in the application.

Follow these steps to print collated copies:

1. Open the [Print](#) dialog box.
2. Select the **General** panel.

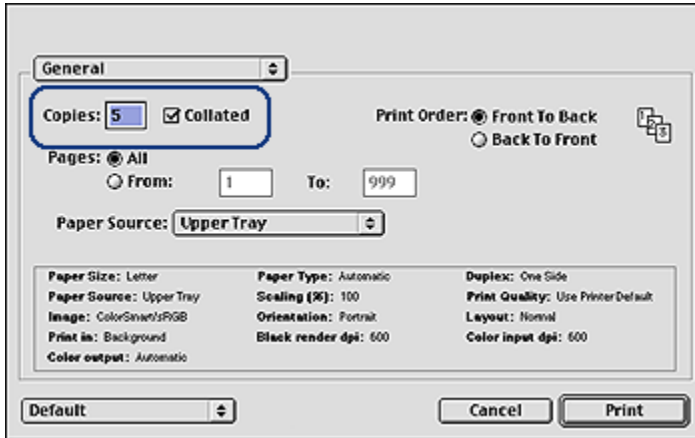

3. In the **Copies** box, type the number of copies that you want to print.
4. Select the **Collated** check box.
5. Select any other print settings that you want, and then click **Print**.

8.4 Automatic two-sided printing

To print a two-sided document automatically, one of the following accessories must be attached to the printer:



Automatic Two-Sided Printing Accessory



Auto Two-Sided Print Accessory with Small Paper Tray

The two-sided printing accessories only support certain paper types. For a list of supported paper types, see the documentation that came with the accessory.

If a two-sided printing accessory is not attached to the printer or you are printing on an unsupported paper type, use [manual two-sided printing](#).

Printing

Follow these instructions to print a two-sided document:

1. Open the **Print** dialog box, and then select the **Layout** panel.

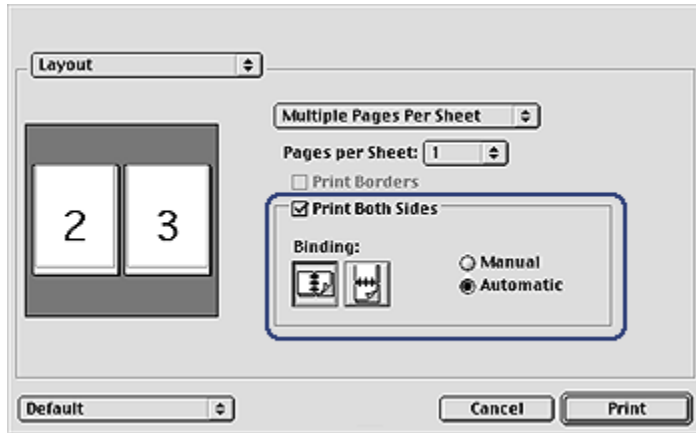

2. Select **Print Both Sides**.
3. Select **Automatic**.
4. Select the appropriate binding:



Book binding



Tablet binding

5. Change any other print settings that you want, and then click **Print**.

After the first side of the page is printed, the printer pauses while the ink dries. After the ink is dry, the paper is pulled back into the duplexer and the reverse side of the page is printed.

Note: Do not remove the paper from the printer until both sides of the page have been printed.

8.5 Manual two-sided printing

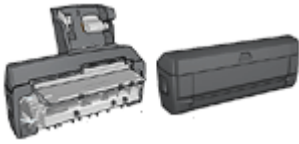

If an optional two-sided printing accessory is attached to the printer, then follow the [automatic two-sided printing instructions](#).

Follow these instructions to print a two-sided document:

1. Open the [Page Setup](#) dialog box, and then click the appropriate orientation option.
2. Click **OK**.
3. Open the [Print](#) dialog box.
4. Select the **Layout** panel.

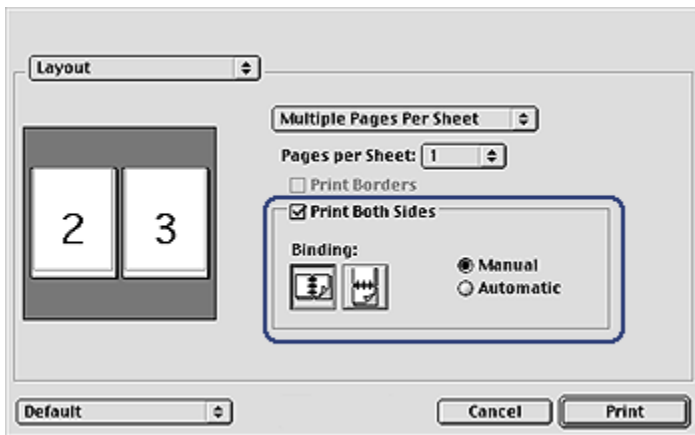

5. Select **Print Both Sides**, and then select **Manual**.
6. Select the appropriate binding:



Book binding



Tablet binding

7. Select any other print settings that you want, and then click **Print**.

The printer automatically prints odd-numbered pages first.

8. After the odd-numbered pages have printed, reload the paper, with the printed side facing up, according to the binding type and orientation that you selected:

- **Book binding with portrait orientation:** Reload the paper as shown below:

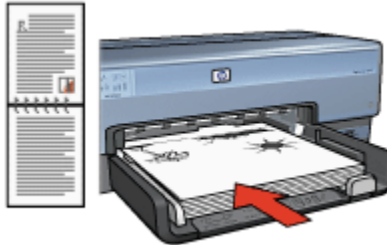

- **Book binding with landscape orientation:** Reload the paper as shown below:

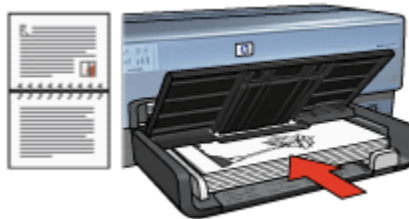

- **Tablet binding with portrait orientation:** Reload the paper as shown below:

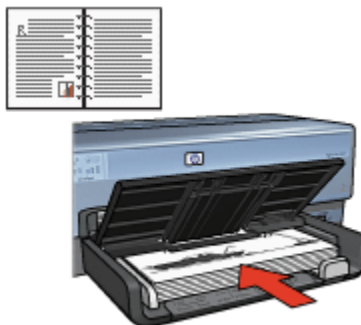

- **Tablet binding with landscape orientation:** Reload the paper as shown below:

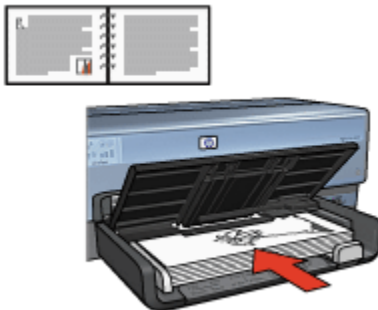

8.6 Printing multiple pages on a single sheet of paper

The printer software allows you to print multiple pages of a document on a single sheet of paper. The printer software automatically resizes the document text and images to fit on the printed page.

Follow these steps to print multiple pages on a single sheet of paper:

1. Open the [Print](#) dialog box.
2. Select the **Layout** panel.

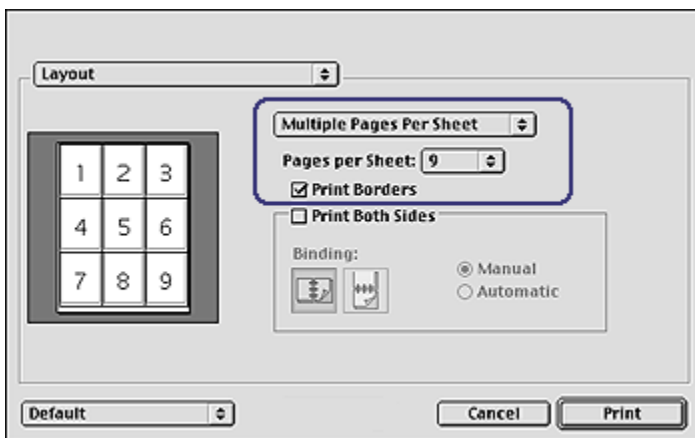

3. In the drop-down list, click **Multiple Pages Per Sheet**.
4. In the **Pages per Sheet** drop-down list, select the number of pages that you want to appear on each sheet of paper.
5. If you want a border to appear around each page image that is printed on the sheet of paper, select the **Print Borders** check box.

6. Select any other print settings that you want, and then click **Print**.

8.7 Selecting a paper type

The printer software offers these options for selecting a paper type:

- Use the [Automatic Paper-Type Sensor](#)
- Select a specific paper type

Using the Automatic Paper-Type Sensor

The [Automatic Paper-Type Sensor](#) automatically selects the print settings appropriate for the media be printed on, particularly when used with HP paper and media.

Note: The **Automatic Paper-Type Sensor** cannot be used for documents that are printed from the [250-Sheet Plain Paper Tray Accessory](#).

Follow these steps to use the Automatic Paper-Type Sensor:

1. Open the [Print](#) dialog box.
2. Select the **Paper Type/Quality** panel.

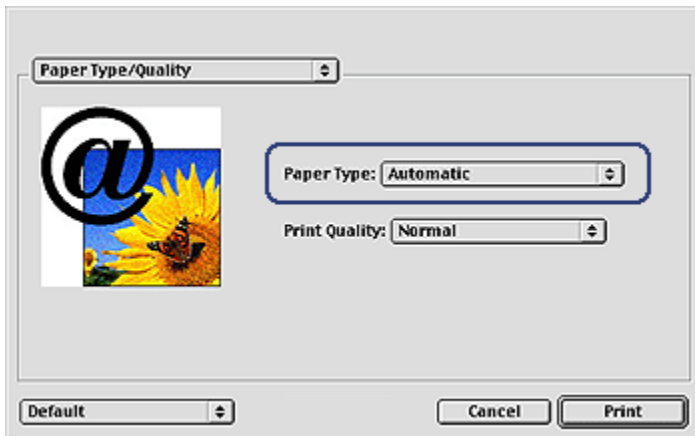

3. In the **Paper Type** drop-down list, click **Automatic**.
4. Select any other print settings that you want, and then click **Print**.

Selecting a specific paper type

When printing a higher-quality document, it is recommended that you select a specific paper type.

Follow these steps to select a specific paper type:

1. Open the [Print](#) dialog box.
2. Select the **Paper Type/Quality** panel.

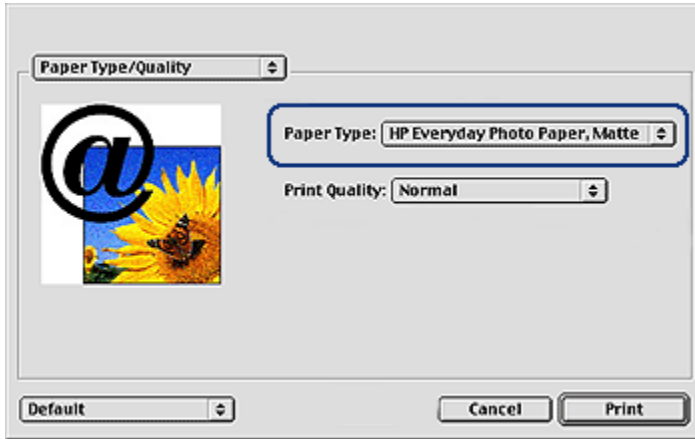

3. In the **Paper Type** drop-down list, click the specific paper type.

Note: The options in the Paper Selection Type drop-down list vary according to the paper category selected. If the selected Paper Selection Group is Plain Paper, then the Paper Selection Type drop-down list becomes inactive.

4. Select any other print settings that you want, and then click **Print**.

8.8 Selecting a print quality

Follow these steps to select a print quality from the printer software:

1. Open the [Print](#) dialog box.
2. Select the **Paper Type/Quality** panel.

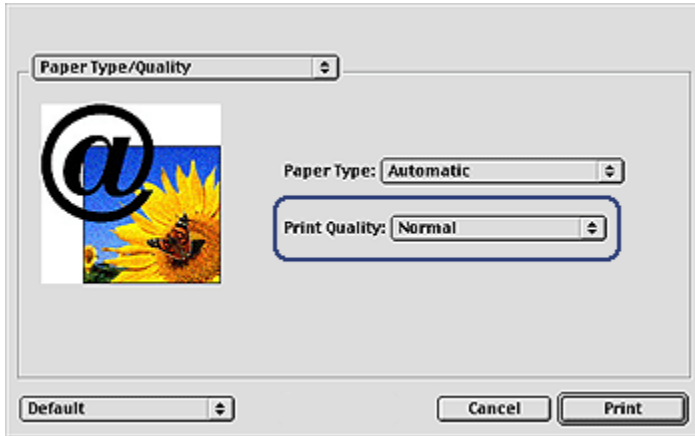

3. Select one of the following options from the **Print Quality** drop-down list:
- **FastDraft:** Prints at the fastest printing speed.
 - **Fast normal:** Prints more quickly than the Normal mode and at a higher print quality than FastDraft.
 - **Normal:** Provides the best balance between print quality and speed. This is the appropriate setting for most documents.
 - **Best:** Provides high-quality printing.
 - **Maximum dpi:** Provides the highest quality printing but requires longer to print than Best and requires a large amount of disk space.

8.9 Resizing a document

Use this feature to shrink or enlarge printed text and graphics without changing the paper size.

Follow these steps to shrink or enlarge text and graphics:

1. Open the [Page Setup](#) dialog box.

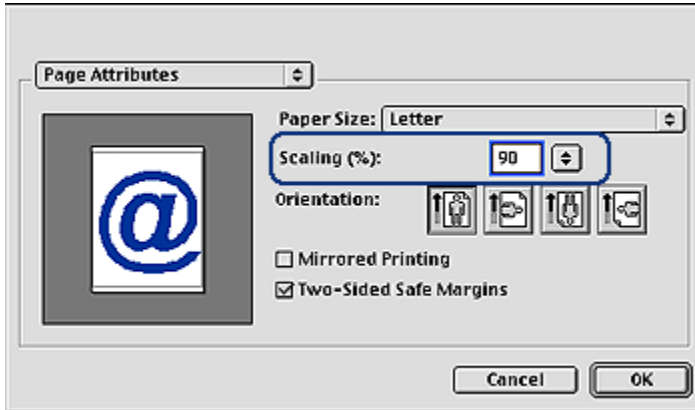

2. In the **Scaling (%)** box, type the percentage by which you want to shrink or enlarge the document.
 - Type a number from 25 to 99 to reduce a document image.
 - Type a number from 101 to 400 to enlarge a document image.
3. Click **OK**, and then print the document.

8.10 Selecting a paper source

The printer offers three sources for paper:



In tray



250-Sheet Plain Paper
Tray Accessory

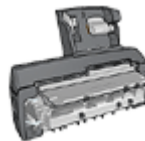

Auto Two-Sided Print Accessory
with Small Paper Tray

Follow these steps to select a paper source:

1. Open the **Print** dialog box.
2. Select the **General** panel.

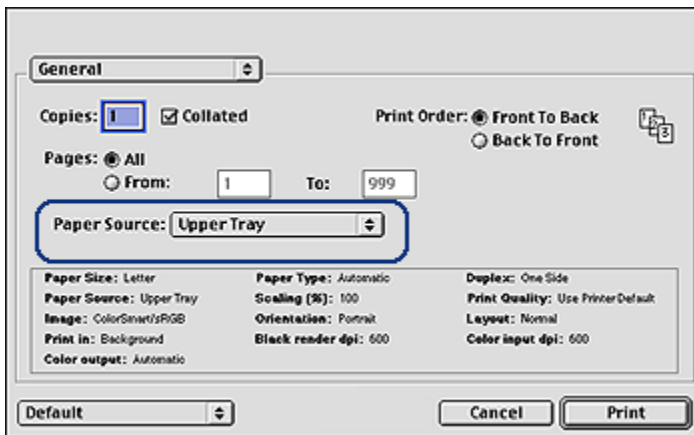

3. In the **Paper Source** drop-down list, click one of the following options:
- **Upper tray**: prints from the In tray.
 - **Lower tray**: prints from the 250-Sheet Plain Paper Tray Accessory.
 - **Upper, then lower**: prints from the In tray. If the In tray is empty, then the printer prints from the 250-Sheet Plain Paper Tray Accessory.
 - **Lower, then upper**: prints from the 250-Sheet Plain Paper Tray Accessory. If the accessory is empty, then the printer prints from the In tray.
 - **Rear tray**: prints from the Auto Two-Sided Print Accessory with Small Paper Tray. This option appears only if the accessory is attached to the printer.

8.11 Printing a borderless brochure

You can print a borderless brochure on glossy brochure paper.

For instructions about printing a borderless photo, see the [borderless photo](#) page.

Guidelines

- Do not print borderless documents in [ink-backup mode](#). Always have two print cartridges installed in the printer.
- Open the file in a software application and assign the image size. Ensure that the size corresponds to the paper size on which you want to print the image.

Printing

Follow these steps to print a borderless document:

1. Open the file that you want to print.
2. Open the [Page Setup](#) dialog box.
3. Click the appropriate borderless paper size in the **Paper Size** list.
4. Click **OK**.
5. Open the [Print](#) dialog box.
6. Select the **Paper Type/Quality** panel.
7. In the **Paper Type** drop-down list, click the appropriate brochure paper.
8. Select any other print settings that you want, and then click **Print**.

9 Printer software

- [Print settings](#)
- [Page Setup dialog box](#)
- [Print dialog box](#)
- [Managing the printer](#)
- [Viewing and changing the status of a print job](#)
- [Printing from the computer desktop](#)

9.1 Print settings

The printer is controlled by software that is installed on your computer. Use the printer software, known as the *printer driver*, to change the print settings for a document.

To specify the paper size, scaling, and orientation for a document, use the [Page Setup](#) dialog box.

To specify other print settings for a document, and to send the document to the printer, use the [Print](#) dialog box.

Mac OS X Classic

Mac OS X Classic is a Mac OS X feature that allows applications that were built for Mac OS 9.x to run on a Mac OS X computer. Mac OS X Classic applications have a Mac OS 9.x interface.

9.2 Page Setup dialog box

Use the **Page Setup** dialog box to modify the layout of a document.

To open the **Page Setup** dialog box, open the software program that you used to create the document, click **File**, and then click **Page Setup**.

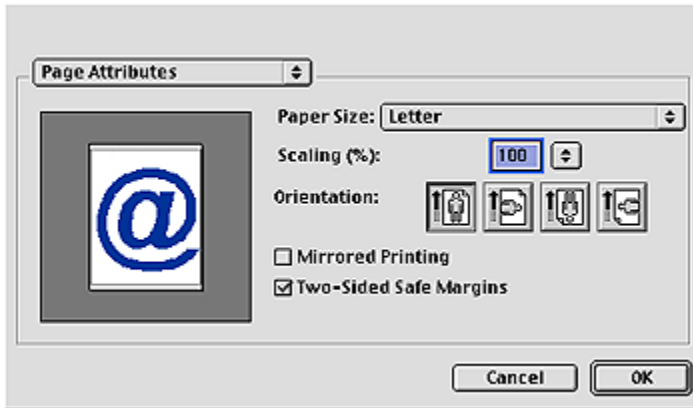

You can use the **Page Setup** dialog box to do the following tasks:

- Set the paper size for a document.
- [Resize](#) a document.
- Specify the document orientation.
- Set safe margins for [automatic two-sided printing](#).

9.3 Print dialog box

Use the **Print** dialog box to modify print settings for the document that you are printing. The options that appear depend on the panel that you selected.

To open the **Print** dialog box, open the document you want to print, click **File**, and then click **Print**.

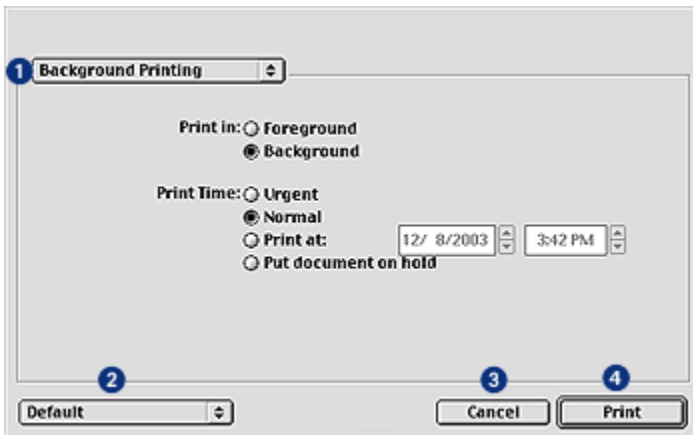

Use the menu and buttons for these functions:

1. **Panel Menu:** Toggles between print setting panels and an application-specific panel.
2. **Default:** Select one of the following options:
 - **Save Settings:** Save the current print settings without printing the document.
 - **Revert to Defaults:** Restore the default print settings.
3. **Cancel:** Close the dialog box without saving the new settings.
4. **Print:** Click this option to print the document.

9.4 Managing the printer

Managing the printer includes the following tasks:

- [Choosing the printer](#)
- [Setting the printer as your default printer](#)
- [Checking the status of the printer](#)

Choosing the printer

Follow these steps to choose the printer:

1. Select **Chooser** from the Apple menu.
2. Click the HP printer icon on the left side of the **Chooser** dialog box.

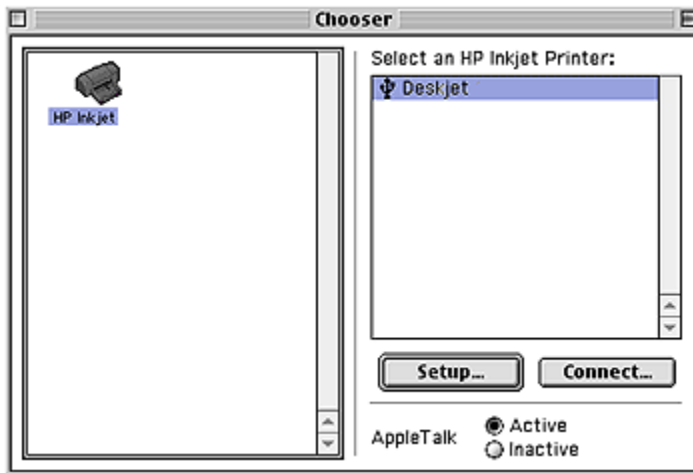

3. Click the HP printer name on the right side of the **Chooser** dialog box.

4. Close the **Chooser**.

Setting the printer as your default printer

Setting the printer as your computer's default printer will automatically route all print jobs to the printer.

You can select another printer for a particular document; however, switching printers might affect a document's formatting and pagination. If you select a printer, always check the document for changes in formatting and pagination before printing.

Follow these steps to set the printer as your computer's default printer:

1. Use **Chooser** to select the printer.
2. Do one of the following:
 - Click the menu bar printer icon at the top of the screen, and then select the printer name.
 - Click the control strip printer icon, and then select the printer name.
 - Click the desktop printer icon, and then click **Set Default Printer** in the **Printing** menu.

Checking the status of the printer

The printer desktop icon shows you the status of the printer:

Icon Meaning



Printer is idle and set as the default printer.



Printer is idle and not set as the default printer.



Printing on the default printer.



Printing stopped on the default printer.



Error on the default printer.



The printer driver is not available.

9.5 Viewing and changing the status of a print job

When printing a document with background printing, use the **Print Status** dialog box to see the status of the document as it is printing.

Opening the Print Status dialog box

Double-click the HP printer icon on the desktop to open the **Print Status** dialog box.

Using the Print Status dialog box

The following options are available in the **Print Status** dialog box:

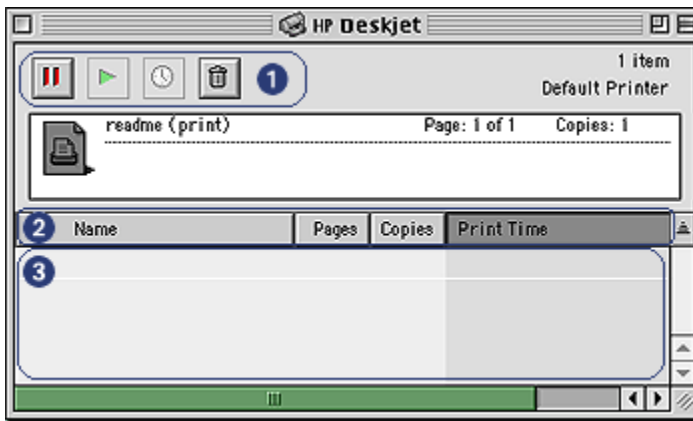

1. **Control Buttons:** Select a print job in the print queue, and then click one of the following buttons to control printing:

 Pause a print job.

 Restart printing.

 Set the print time.

 Delete a print job.

2. **Column Titles:** Click a column title to sort print jobs.
3. **Print Queue:** Select a print job, and then drag it to a new position in the print queue.

9.6 Printing from the computer desktop

Desktop printing is useful when you want to print a number of documents at the same time or print a document that is formatted for a particular printer.

Use one of the following methods to print from the desktop:

- Drag the icons for the documents that you want to print to the printer icon on the desktop.
- Select the icons for the documents that you want to print, click **File**, and then click **Print**. Select the options that you want from the **Print** dialog box, and then click **Print**.

10 Maintenance

- [Installing print cartridges](#)
- [Aligning print cartridges](#)
- [Calibrating color](#)
- [Automatically cleaning print cartridges](#)
- [Manually cleaning the print cartridges](#)
- [Printing a test page](#)
- [View estimated ink levels](#)
- [Removing ink from skin and clothing](#)
- [Maintaining print cartridges](#)
- [Maintaining the printer body](#)
- [Using the HP Inkjet Toolbox](#)

10.1 Installing print cartridges

Print cartridges

Print cartridge combinations

For printing most documents, use the tri-color print cartridge and the black print cartridge. When printing photos, you can use either the [photo print cartridge](#) or the [gray photo print cartridge](#) along with the tri-color print cartridge cradle.

Always install the tri-color print cartridge in the *left* print cartridge cradle compartment.

Install the black, photo, or gray photo print cartridge in the *right* print cartridge cradle compartment.

Selection numbers

Before buying replacement print cartridges, verify the correct selection numbers in the reference guide that came with the printer.

You can also find the selection number on the print cartridge that you are replacing.

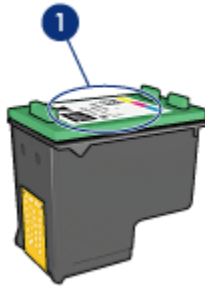

1. Selection number label

Ink back-up mode

The printer can operate with only one print cartridge installed. For more information, see the [ink back-up mode](#) page.

Installation instructions

Follow these steps so install a print cartridge:

1. Verify that the printer is turned on.
2. Load a stack of letter-size or A4-size plain, white paper in the In tray.
3. Open the printer cover.
4. Wait until the print cartridge cradle is idle and silent, and then lift the print cartridge latch to the open position.

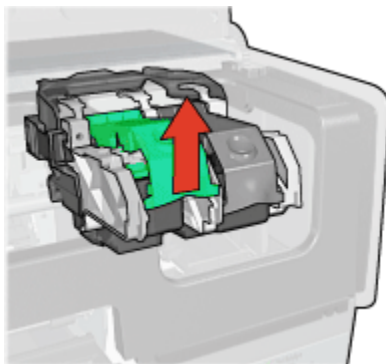

5. Slide the print cartridge out of the print cartridge cradle.

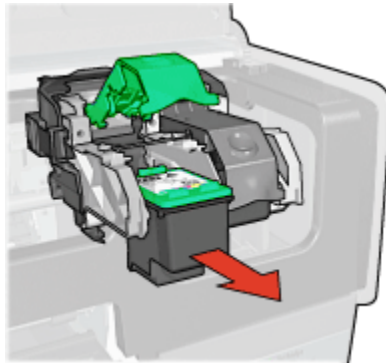

6. Remove the replacement print cartridge from its packaging and carefully remove the pink, plastic tape.



1. Remove the pink tape only



Caution: Do not touch the print cartridge ink nozzles or copper contacts. Touching these parts will result in clogs, ink failure, and bad electrical connections. Do not remove the copper strips. They are required electrical contacts.



1. Do not touch the copper strips
7. Hold the print cartridge so that the copper strips are on the bottom and facing toward the printer, and then slide the print cartridge into the cradle as shown.

Note: After you insert the print cartridge, verify that the copper contacts of the print cartridge touch the back of the print cartridge cradle.

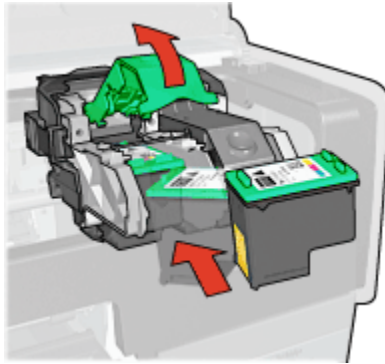

8. Push down on the print cartridge latch until it snaps closed.

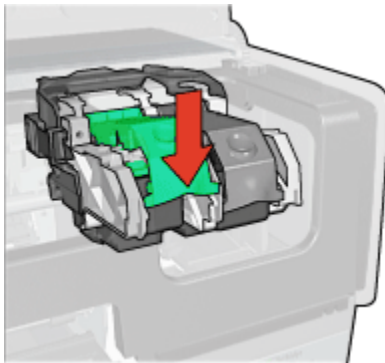

9. Close the printer cover.

The printer automatically prints a calibration page.

For information about storing print cartridges, see the [print cartridge storage](#) page.

For information about recycling empty print cartridges, see the [print cartridge recovery](#) page.



Warning: Keep both new and used print cartridges out of the reach of children.

10.2 Aligning print cartridges

The printer automatically aligns the print cartridges after a new print cartridge is installed. You can also align the print cartridges at other times to ensure optimal print quality.

To calibrate the print cartridges:

1. Load letter-size or A4-size plain white paper in the In tray.
2. Open the [HP Inkjet Toolbox](#).
3. Select the **Calibrate** panel.
4. Click the **Align** button, and then follow the onscreen instructions.

10.3 Calibrating color

Perform a color calibration only if the colors in photographs printed with the [photo print cartridge](#) are consistently tinted.

Before performing a color calibration, [align the print cartridges](#), then reprint your photograph. If the color is still tinted, then perform a color calibration.

To calibrate color:

1. Load letter-size or A4-size plain white paper in the In tray.
2. Verify that a [photo print cartridge](#) is installed in the printer.
3. Open the [HP Inkjet Toolbox](#).
4. Select the **Calibrate Color** panel.
5. Follow the onscreen instructions.

10.4 Automatically cleaning print cartridges

If your printed pages are missing lines or dots, or if they contain ink streaks, the print cartridges might be [low on ink](#) or might need to be cleaned.

If the print cartridges are not low on ink, follow these steps to clean the print cartridges automatically:

1. Open the [HP Inkjet Toolbox](#).
2. Select the **Clean** panel.
3. Click the **Clean** button, and then follow the onscreen instructions.



Caution: Clean print cartridges only when necessary. Unnecessary cleaning wastes ink and shortens the life of the cartridge.

10.5 Manually cleaning the print cartridges

If the printer is used in a dusty environment, a small amount of debris can accumulate on the print cartridge contacts.

Gathering cleaning supplies

You will need the following items to clean the print cartridges.

- Distilled water (tap water can contain contaminants that can damage the print cartridge)
- Cotton swabs or other soft, lint-free material that will not stick to the print cartridge

Be careful not to get ink on your hands or clothing as you clean.

Preparing to clean

1. Press the **Power** button to turn on the printer, and then raise the printer cover.
2. Remove the print cartridges and place them on a piece of paper with the nozzle plate facing up.



1. Nozzle plate



Caution: Do not leave the print cartridges outside the printer for more than 30 minutes.

Cleaning instructions

1. Lightly moisten a cotton swab with distilled water and squeeze any excess water from the swab.
2. Wipe the print cartridge copper contacts with the cotton swab.



Caution: Do not touch the print cartridge ink nozzles. Touching the ink nozzles will result in clogs, ink failure, and bad electrical connections.



1. Clean only the copper contacts

Repeat this process until no ink residue or dust appears on the swab that you use to clean the contacts.

3. Insert the print cartridges in the printer, and then close the printer cover.

10.6 Printing a test page

Follow these steps to print a test page:

1. Open the [HP Inkjet Toolbox](#).
2. Select the **Test** panel.
3. Click the **Print a test page** button, and then follow the onscreen instructions.

10.7 View estimated ink levels

Follow these steps to view the estimated ink levels of the print cartridges that are installed in the printer:

1. Open the [HP Inkjet Toolbox](#).
2. Select the **Ink Levels** panel.

10.8 Removing ink from skin and clothing

Follow these instructions to remove ink from skin and clothing:

Surface	Remedy
Skin	Wash the area with an abrasive soap.
White fabric	Wash the fabric in cold water and use chlorine bleach.
Color fabric	Wash the fabric in cold water and use sudsy ammonia.



Caution: Always use cold water to remove ink from fabric. Warm or hot water can set the ink into the fabric.

10.9 Maintaining print cartridges

The following tips will help maintain HP print cartridges and ensure consistent print quality:

- Keep all print cartridges in their sealed packages until they are needed. Print cartridges should be stored at room temperature (15 to 35 degrees C or 59 to 95 degrees F).
- Do not remove the plastic tape covering the ink nozzles until you are ready to install the print cartridge in the printer. If the plastic tape has been removed from the print cartridge, do not attempt to reattach it. Reattaching the tape damages the print cartridge.

Storing print cartridges

When print cartridges are removed from the printer, store them in a print cartridge protector or an airtight plastic container.

A print cartridge protector comes with the photo print cartridge and the gray photo print cartridge. If you store the print cartridge in an airtight plastic container, make sure that the ink nozzles face down but are not in contact with the container.

Inserting the print cartridge into the print cartridge protector

Slide the print cartridge at a slight angle into the protector, and snap it securely in place.



Removing the print cartridge from the print cartridge protector

Press down and back on the top of the protector to release the cartridge. Slide the cartridge out of the protector.



Caution: Do not drop the print cartridge. Dropping the print cartridge can damage it.

10.10 Maintaining the printer body

Because the printer ejects ink onto the paper in a fine mist, ink smudges will eventually appear on the printer case and adjacent surfaces. To remove smudges, stains, or dried ink from the exterior of the printer, use a soft cloth moistened with water.

When cleaning your printer, keep these tips in mind:

- Do not clean the interior of the printer. Keep all fluids away from the interior.
- Do not use household cleaners or detergent. In the event that a household cleaner or detergent is used on the printer, wipe the printer's exterior surfaces with a soft cloth that has been moistened with water.
- Do not lubricate the support rod that the print cartridge cradle uses to slide back and forth. Noise is normal when the cradle moves back and forth.

10.11 Using the HP Inkjet Toolbox

The **HP Inkjet Toolbox** contains tools to calibrate the printer, clean the print cartridges, print a test page, and find Web site support information.

Opening the HP Inkjet Toolbox

1. Double-click the **Macintosh HD** icon on the desktop.
2. Double-click **Applications**, double-click **Utilities**, double-click **HP**, and then double-click **HP Printer Selector**.

3. Depending on how the printer is connected to your printer, click **Local** or **Network**.

Note: If the printer is connected to the printer by a USB cable, click **Local**.

4. Select the printer, and then click the **Utilities** button.

HP Inkjet Toolbox panels

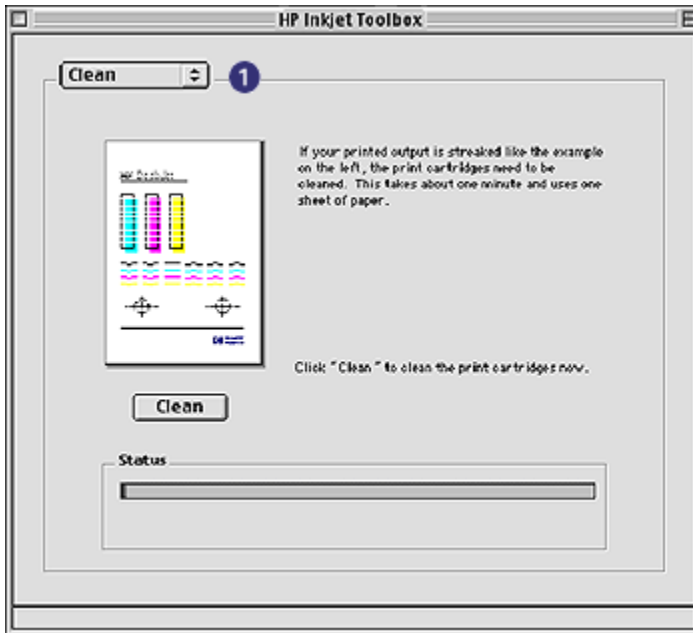

Select the appropriate panel to view HP Inkjet Toolbox options:

- **WOW!**: Prints a sample page to view the output quality of the printer.
- **Test**: Prints a test page to confirm communication with printer.
- **Clean**: Cleans the print cartridges.
- **Ink Level**: Provides estimated ink levels.
- **Calibrate**: Calibrates the print cartridges.
- **Calibrate Color**: Adjusts color to correct problems with tint.
- **Supplies**: Provides print cartridge selection numbers.
- **Support**: Provides access to the HP Web site where you can find support for the printer and information about HP products and supplies.
- **Register**: Accesses the HP Web site to register the printer.

11 Troubleshooting

- [Ethernet problems](#)
- [Wireless networking problems](#)
- [Printer is not printing](#)
- [Paper jam](#)
- [Paper problems](#)
- [Print quality is poor](#)
- [Document is misprinted](#)
- [Photos are not printing correctly](#)
- [Banners are not printing correctly](#)
- [Borderless printing problems](#)
- [Error messages](#)
- [Printer lights are on or flashing](#)
- [Document prints slowly](#)
- [PictBridge problems](#)
- [If you continue to have problems](#)

11.1 Ethernet problems

Printer does not print

Print an [HP Report page](#).

If the HP Report page **does not** print, verify the following:



- The printer is set up and powered on.
- The [print cartridges are installed](#) correctly.
- The printer is on and the paper tray is loaded.
- The printer is free of paper jams.

If any of these items are problems,, then see the [printer is not printing page](#).

If the HP Report page **does** print, try the following steps:

Link light



If the printer still does not print, then look at the Link light on the back of the printer:

State of the Link light	Task
<p>On</p> 	<p>Resend the document, then look at the Activity light.</p>
<p>Off</p> 	<p>Verify the following:</p> <ul style="list-style-type: none"> • The Ethernet cable is securely connected to the printer. • The network hub, switch, or router is on and working properly. • The printer is connected to the network.

Activity light

Follow these steps if the Link light is on, but the printer does not print:

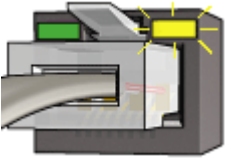
1. Wait until the printer is idle.
2. Try to reprint the document.
3. Look at the Activity light on the back of the printer.

State of the Link light	Task
<p>Flashing</p> 	<p>The Ethernet connection is operating correctly. Try these solutions again.</p>
<p>Off</p> 	<p>Verify the following:</p> <ul style="list-style-type: none"> • The printer is selected in the application from which you are trying to print. • The computer is connected to the network. • A personal software firewall might be blocking communication between the printer and the computer. Follow these steps.

The printer cannot be discovered

For instructions on discovering the printer, see the *network guide* that came with the printer.

Cannot open the printer's embedded Web server (EWS)

Verify the following:

- You are not using a phone cord to connect the printer to the network
- The [Ethernet cable](#) is securely connected to the printer.
- The network [hub](#), [switch](#), or [router](#) is on and working properly.
- The computer that you are using is connected to the network.

If you still cannot access the printer's EWS, then follow these steps:

1. Print an [HP Report page](#).
2. Find the printer's [IP address](#).
3. Launch your Internet browser.

Note: Use Microsoft Internet Explorer 5.0 or higher, Netscape 4.75 or higher, or Safari 1.0 or higher.

4. Enter the printer's IP address in the address box, then press **Enter**.

A personal software firewall is blocking communication between the printer and the computer

The personal software firewall is a security program that protects a computer from intrusion. However, the personal firewall might block communication between the computer and the printer.

If you cannot communicate with the printer, try disabling the personal firewall. If you are still unable to communicate with the printer, then re-enable the firewall.

If disabling the firewall allows you to communicate with the printer, you might want to assign the printer a static IP address and then re-enable the firewall. To assign the printer a static IP address, see the network guide that came with the printer.

11.2 Wireless communication problems

Print an [HP Report page](#).

If the HP Report page **does not** print, verify the following:

- The printer is set up and powered on.
- The [print cartridges are installed](#) correctly.
- The printer is on and the paper tray is loaded.

- The printer is free of paper jams.

If any of these items are problems, then see the [printer is not printing page](#).



If the HP Report page **does** print, try the following steps:

Check the Wireless Status light

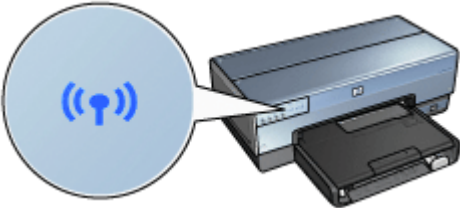
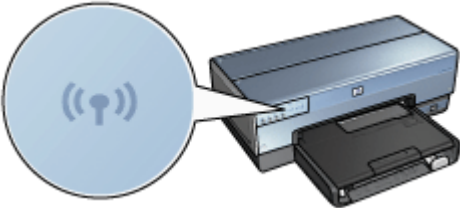
Look at the printer's [Wireless Status light](#):

State of the Wireless Status light	Task
On 	Follow these steps .
Off 	Verify the following: <ul style="list-style-type: none">• An Ethernet cable is not connected to the printer. Connecting an Ethernet cable to the printer automatically turns off the wireless radio. Unplug the cable.• The printer is plugged in.

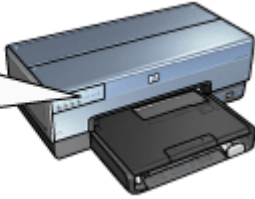
If the Wireless Status light is on, try reprinting the document, then look at the Wireless Status light:

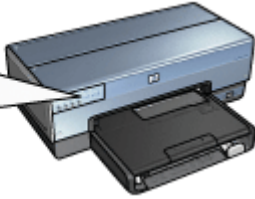
State of the Wireless Status light	Task
<p>Flashes</p>  	<p>The printer's wireless communications feature is operating correctly. Try these solutions, again.</p>
<p>Does not flash</p>  	<p>The wireless radio is functioning but the printer and the computer cannot communicate.</p> <ul style="list-style-type: none"> • The printer's network settings do not match the settings for your network. Follow these steps. • The computer might be set to the wrong network location. Follow these steps. • A personal software firewall might be blocking communication between the printer and the computer. Follow these steps.

Printer's network settings do not match the settings for the network

The printer's network settings must match those of your network.

Printer has the wrong network settings

1. Do one of the following to find the settings for your network:

Printer communication mode	Task
Infrastructure network	Open the Wireless Access Point's (WAP) configuration utility .
Ad hoc network	Open the TCP/IP Control Panel.

2. Compare the network's settings to those that appear on the HP Report page. Note any differences. Possible problems include:

Problem	Solution
The WAP filters hardware addresses (MAC addresses)	Follow these steps .
One of these settings in the printer might be incorrect: <ul style="list-style-type: none"> • Communication mode • Network Name (SSID) • Channel (Ad hoc networks only) • Authentication Type • Encryption • WPA 	Follow these steps .

3. Reprint the document.

If the document still does not print, then reset the printer to its [factory defaults](#) and use the printer software CD to reinstall the printer software.

Computer is set to the wrong network location

A [network location](#) is a set of network settings unique to a given network. A single computer might have several network locations (for example, one for a home network and one for an office network).

Use the **Location Manager** control panel to create and edit network locations.

The radio signal is weak

If the printer is printing slowly, then the radio signal might be weak. Look at the [Signal Strength indicator](#). If none or only one of the bars is illuminated, then follow the guidelines below.

Reducing interference in a wireless network

The following tips will help reduce the chances for interference in a wireless network:

- Keep the wireless devices away from large metal objects, such as filing cabinets, and other electromagnetic devices, such as microwaves and cordless telephones, as these objects can disrupt radio signals.
- Keep the wireless devices away from large masonry structures and other building structures as these objects can absorb radio waves and lower signal strength.
- For an infrastructure network, position the WAP in a central location in line of sight with the wireless devices on the network.
- Keep all wireless devices on the network within range of one another.

A personal software firewall is blocking communication between the printer and the computer

The personal software firewall is a security program that protects a computer from intrusion. However, the personal firewall might block communication between the computer and the printer.

If you cannot communicate with the printer, try disabling the personal firewall. If you are still unable to communicate with the printer, then re-enable the firewall.

If disabling the firewall allows you to communicate with the printer, you might want to assign the printer a static IP address and then re-enable the firewall. To assign the printer a static IP address, see the network guide that came with the printer.

The Wireless Access Point filters MAC addresses

MAC filtering is a security feature in which a [Wireless Access Point \(WAP\)](#) is configured with a list of [MAC addresses](#) (also called "hardware addresses" of devices that are allowed to gain access to the network through the WAP.

If the WAP does not have the hardware address of a device attempting to access the network, the WAP denies the device access to the network.

If the WAP filters MAC addresses, then the printer's MAC address must be added to the WAP's list of accepted MAC addresses.

1. Print an [HP Report page](#).
2. Find the printer's hardware address on the HP Report page.
3. Open the WAP's configuration utility, then add the printer's hardware address to the list of accepted MAC addresses.

Printer has the wrong network settings

If one of these network settings in the printer is incorrect, you will not be able to communicate with the printer:

- [Communication Mode](#)
- [Network Name \(SSID\)](#)
- [Channel \(Ad hoc networks only\)](#)
- [Authentication Type](#)
- [Encryption](#)
- [WPA](#)

Follow these steps to correct the printer's network settings:

1. Connect the printer to your network or computer with an Ethernet cable.
2. Open the printer's [embedded Web server \(EWS\)](#).

3. Click the **Networking** tab, and then click **Wireless (802.11)** under the **Connections** heading.
4. Use the Wireless Setup wizard on the **Wireless Setup** tab to change the printer's settings to match the settings of the network.
5. Close the printer's EWS, then disconnect the Ethernet cable from the printer.

11.3 Printer is not printing

Verify the following

- The printer is connected to the power source.
- The cable connections are secure.
- The printer is turned on.
- The print cartridges are [correctly installed](#).
- The paper or other media is correctly loaded in the In tray.
- The printer cover is closed.
- The rear access door or optional duplexer is attached.

Check the printer lights

The printer lights indicate the printer status and alert you to potential problems.

For more information, see [printer lights are on or flashing](#).

Check the printer cable connection

If the printer cable is attached to a USB hub, a printing conflict might exist. Use one of these methods for solving the conflict:

- Attach the printer USB cable directly to your computer.
- When printing, do not use other USB devices that are attached to the hub.

If the printer still does not print

Select the topic below that best describes the problem:

- [Paper jam](#)
- [Out of paper message](#)
- [Printer ejects paper](#)

11.4 Paper jam

Do **not** clear a paper jam from the front of the printer.

Follow these steps to remove a paper jam:

1. Press the **Resume** button.

If the paper jam does not clear, then go to the next step.

2. Push the two latch handles on the rear access door toward each other, and then remove the door.

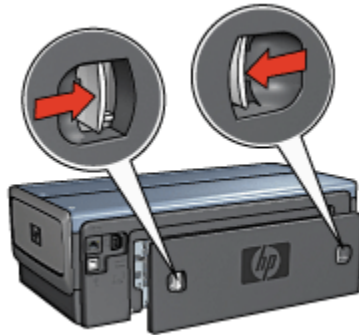

3. Remove any paper that is inside the printer by pulling it out from the back of the printer.

If you are printing labels, verify that a label did not become detached from the label sheet while passing through the printer.

4. Replace the rear access door.

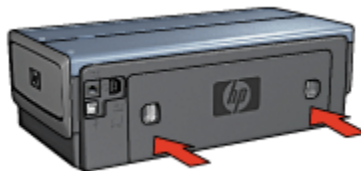

5. Press the **Resume** button.

Accessories?



If the Two-Sided Printing Accessory is attached to the printer, follow these [steps to clear a paper jam from the Two-Sided Printing Accessory](#).



If the Auto Two-Sided Print Accessory with Small Paper Tray is attached to the printer, follow these [steps to clear a paper jam Auto Two-Sided Print Accessory with Small Paper Tray](#).

11.5 Paper problems

Printer prints on multiple sheets at once

Paper weight

The printer might print on multiple sheets of paper at once if the paper is under the recommended paper weight. Use paper that meets the recommended paper weight. For paper weight specifications, see the reference guide that came with the printer.

Paper is loaded improperly

The printer might print on multiple sheets of paper at once if the paper is loaded too far toward the back of the printer. Reload paper into the paper tray, pushing the paper until you feel resistance.

The printer also might print on multiple sheets if different paper types are loaded in the printer. For example, photo paper might be mixed with plain paper. Empty the paper tray and load only the paper type that is appropriate for the document that you are printing.

Printer will not feed paper

Try one or more of the following solutions:

- Reduce the number of sheets in the paper tray.
- Remove the paper from the tray, then reload the paper.
- Use a different type of paper.

Printer ejects the paper

If the printer ejects the paper, do one of the following:

- Move the printer away from direct sunlight. The printer may have been placed in direct sunlight which can affect the [Automatic Paper-Type Sensor](#).
- Select a paper category other than **Automatic**.
- If you are performing a [color calibration](#), install both the tri-color and photo [print cartridges](#).
- If printing a borderless document, follow these [guidelines](#).

Other paper problems

- For information about clearing a paper jam, see the [paper jam](#) page.
- If an out-of-paper message appears, see the [error messages](#) page.

11.6 Print quality is poor

For help with photo print quality, see the [photo troubleshooting](#) page.

Streaks and missing lines

If your printed pages are missing lines or dots, or if streaks appear, the print cartridges might be [low on ink](#) or might need to be [cleaned](#).

Print is faded

1. Verify that neither of the print cartridges is [low on ink](#).
If a print cartridge is low on ink, consider [replacing the print cartridge](#) when the print quality lessens.
If the print cartridge is not low on ink, [clean the print cartridge](#).
2. Verify that a black print cartridge is installed.
If the black text and images on your printouts are faded, you might be printing with only the tri-color print cartridge. Insert a black print cartridge, in addition to the tri-color print cartridge, for optimal black print quality.
3. Verify that the protective piece of plastic tape has been removed from the print cartridges.



1. Plastic tape

4. Consider selecting a higher print quality.

Increase the ink density

1. Open the [Print](#) dialog box.
2. Select the **Ink** panel.
3. Move the **Ink Density** slider toward **Heavy**.
4. Move the **Dry Time** slider toward **More**.
5. Click **Print**.

Blank pages print

- The protective piece of plastic tape might still be attached to the print cartridges. Verify that the plastic tape has been removed from the print cartridges.
- The print cartridges might be out of ink. Replace one or both empty print cartridges.
- The printer might be in direct sunlight. Direct sunlight can adversely affect the Automatic Paper-Type Sensor. Move the printer out of direct sunlight.
- You might be trying to print a borderless document with only the black print cartridge installed. When printing a borderless document, always have the tri-color print cartridge and another print cartridge installed.

Too much or too little ink appears on the page

Follow these steps to adjust the ink density:

1. Open the [Print](#) dialog box.
2. Select the **Ink** panel.
3. Move the **Ink Density** slider toward **Light** or **Heavy**.
4. Click **Print**.

11.7 Document is misprinted

Text and images are misaligned

If the text and images on your printouts are misaligned, then [align](#) the print cartridges.

Envelope is printed at an angle

1. Slide the flap inside the envelope before loading it in the printer.
2. Confirm that the paper guides fit firmly against the edge of the envelope.
3. Reprint the envelope.

Parts of the document are missing or printed in the wrong place

1. Open the [Page Setup](#) dialog box and verify the following settings:
 - **Paper Size:** The appropriate paper size.
 - **Scale:** Select to scale text and graphics to fit on the paper.
 - **Orientation:** Verify the appropriate orientation.
2. Open the [Print](#) dialog box.
3. Select the **Layout** panel.
4. If **Tiling** is selected, and you are not printing a poster, click **Multiple Pages per Sheet**, and then click **1 (Normal)** in the **Pages Per Sheet** box.

Printout does not reflect selected print settings

Some software applications allow you to set certain print settings. The software application's print settings might differ from the printer settings that you specified in the **Print** or **Page Setup** dialog boxes.

Change the appropriate print settings within the software application to match the settings on the **Print** or **Page Setup** dialog boxes.

11.8 Photos are not printing correctly

Check the paper tray

1. Place the photo paper in the In tray with the side to be printed on facing down.
2. Slide the paper forward until it stops.
3. Slide the paper guide firmly against the edge of the paper.

Check the printer settings

1. Open the [Page Setup](#) dialog box and verify the following settings:

Panel	Setting
Page Attributes	Paper Size: The appropriate paper size Orientation: The appropriate orientation

2. Open the [Print](#) dialog box and verify the following settings:

Panel	Setting
General	Source: Upper Tray
Paper Type/Quality	Paper Type: The appropriate photo paper type Print Quality: Best or Maximum dpi
Digital Photography	If desired for photo enhancement options (see digital photography)

Colors are tinted or incorrect

If colors in photographs appear tinted or incorrect, follow these steps:

1. [Align](#) the print cartridges.
2. Reprint the photograph.
3. If colors are still tinted or incorrect, [calibrate the color](#).
A photo print cartridge must be installed for color calibration.
4. Reprint the photograph.
5. If colors are still tinted or incorrect, then open the [Print](#) dialog box, select the **Color** panel, and then take one of the following actions:
 - If the colors are too yellow, move the **Color Tone** slider towards **Cooler**.
 - If the colors are too blue, move the **Color Tone** slider towards **Warmer**.
6. Reprint the photograph.
7. If colors are still tinted or incorrect, [align](#) the print cartridges.

Part of the photograph is faded

Fading occurs on the edges of a printout



Verify that photo paper is not curled. If the photo paper is curled, place the paper in a plastic bag and gently bend it the opposite direction of the curl until the paper lies flat. If the problem persists, then use photo paper that is not curled.

For instructions about preventing photo paper from curling, see the [photo paper storage](#) page.

Fading occurs near the edges of a printout



Try the following:

- Install a [photo print cartridge](#) in the printer.
- Rotate the image 180 degrees.

11.9 Banners are not printing correctly

Check the paper tray

- Unfold and refold the paper when several sheets feed into the printer at one time.
- Confirm that the unattached edge of the banner paper stack is on top and pointing into the printer.
- Verify that the correct paper for banner printing is in use.

Check the printer settings

Open the [Page Setup](#) dialog box and verify the following setting:

Panel	Setting
Page Attributes	Paper Size: Select A4 Banner or US Letter Banner

Check the software

Verify that the software application you are using prints banners. Not all software applications print banners.

11.10 Borderless printing problems

Guidelines

When printing borderless printouts, follow these guidelines:

- Verify that the paper size that is specified in the [Page Setup](#) dialog box matches the size of the paper that is loaded in the In tray.
- Select the appropriate paper type in the **Paper Type/Quality** panel.
- Do not print borderless documents in the [ink-backup mode](#). Always have two print cartridges installed in the printer.

Part of the photograph is faded

Fading occurs on the edges of a printout



Verify that photo paper is not curled. If the photo paper is curled, place the paper in a plastic bag and gently bend it the opposite direction of the curl until the paper lies flat. If the problem persists, then use photo paper that is not curled.

For instructions about preventing photo paper from curling, see the [photo paper storage](#) page.

Fading occurs near the edges of a printout



Try the following:

- Install a [photo print cartridge](#) in the printer.
- Rotate the image 180 degrees.

Streaks appear in a light portion of a printout



Try the following:

- Install a [photo print cartridge](#) in the printer.
- Rotate the image 180 degrees.

Image is printed at an angle



Follow these steps if the image is printed at an angle:

1. Remove all paper from the In tray.
2. Load the photo paper correctly in the In tray.
3. Verify that the paper guides fit firmly against the media.

Printout has an unwanted border

For most photo paper types



If the printout has an unwanted border, then [align the print cartridges](#).

For photo paper with a tear-off tab

If the border appears below the tear-off tab, then remove the tab.

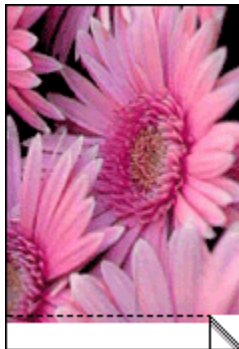

If the border appears above the tear-off tab, then [align the print cartridges](#).

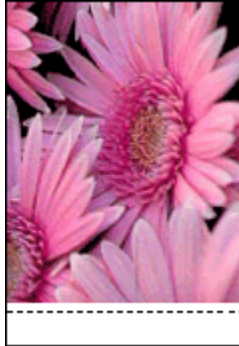

11.11 Error messages

Out of paper message

If the In tray or optional lower tray contains paper

1. Verify the following:
 - There is sufficient paper in the paper tray (at least ten sheets).
 - The paper tray is not overly full.
 - The paper stack is touching the back of the paper tray.
2. Slide the paper guides so that they fit *firmly* against the edges of the paper.
3. Press the **Resume** button to continue printing.

If the In tray or optional lower tray is empty

1. Load paper in the tray.
2. Press the **Resume** button to continue printing.

The error message 'there is a problem with the print cartridges' appears

The Print Cartridge Status light comes on when one or both of the print cartridges is low on ink.

The light flashes when one or both of the print cartridges is improperly installed or malfunctioning.

For instructions about correcting the problem, see [printer lights are on or flashing](#).

11.12 Printer lights are on or flashing

What the lights indicate

The printer lights indicate the printer status.

Wireless Status light is flashing

For information about the Wireless Status light, see the [Wireless Status light page](#).

Power light is flashing

The printer is preparing to print.

The light stops flashing when the printer has received all data.

Resume light is flashing

There might be a paper jam

Follow these instructions to [clear a paper jam](#).

Print cartridge status light is on or flashing

If the light is on and not flashing

Check to see if a print cartridge is [low on ink](#).

If a print cartridge is low on ink, consider [replacing the print cartridge](#).

If neither print cartridge is low on ink, press the **Resume** button. If the Print Cartridge Status light remains on, turn off, then turn on the printer.

If the light is on and flashing

Verify that the [correct print cartridges](#) are installed.

If you were printing a borderless document when the light started flashing, follow these [guidelines](#).

Otherwise, follow these steps:

1. Open the printer's top cover, remove the black or photo print cartridge, then close the cover.
2. Do one of the following:
 - *If the light is flashing:* Open the top cover, replace the print cartridge you removed, then remove the tri-color print cartridge. Go to step 3.
 - *If the light is off:* There is a problem with the print cartridge you removed. Go to step 3.
3. [Manually clean](#) the print cartridge.

After cleaning the print cartridge, reinsert it into the printer.

If the print cartridge status light continues to flash, [replace the print cartridge](#).

All lights are flashing

Restart the printer.

1. Press the **Power** button to turn off the printer, then press the **Power** button to restart the printer.

Proceed to step 2 if the lights continue to flash.

2. Press the **Power** button to turn off the printer.
3. Disconnect the printer power cord from the electrical outlet.
4. Reconnect the printer power cord to the electrical outlet.
5. Press the **Power** button to turn on the printer.

Power-cord light

The light on the power cord illuminates when electricity is flowing through the cord. If the light is off, then the cord is not receiving power.

11.13 Document prints slowly

Several variables can slow the printer's performance.

Multiple software applications are open

The computer does not have sufficient resources for the printer to print at its optimum speed.

To increase printer speed, close all unnecessary software programs when printing.

Complex documents, graphics, or photographs are printing

Documents containing graphics or photographs print slower than text documents.

Best or Maximum dpi print mode is selected

The printer prints slower when **Best** or **Maximum dpi** is selected as the print quality. To increase the printer speed, select a different print quality mode.

Printer driver is outdated

An outdated printer driver may be installed.

For information about updating the printer driver, visit the HP Web site at www.hp.com/support.

Two-sided documents are printing

Printing two-sided documents takes more time than printing single-sided documents.

Computer does not meet system requirements

If your computer does not have enough RAM or does not have a large amount of free space on the hard drive, then the printer processing time will be longer.

1. Verify that the computer hard disk space, RAM, and processor speed meet the system requirements.

For the system requirements, see the reference guide that came with the printer.

2. Make space available on the hard drive by deleting unneeded files.

Printer is in ink-backup mode

The printer might print more slowly if it is in [ink-backup mode](#).

To increase the print speed, use two print cartridges in the printer.

11.14 If you continue to have problems

If you continue to have problems after investigating the troubleshooting topics, turn off your computer and then restart it.

If you still have problems after restarting your computer, go to HP customer support at www.hp.com/support.

12 Optional accessories

The following optional accessories are available to be used with your HP printer.



Automatic Two-Sided
Printing Accessory

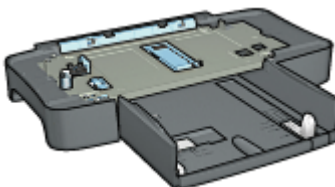

250-Sheet Plain Paper Tray

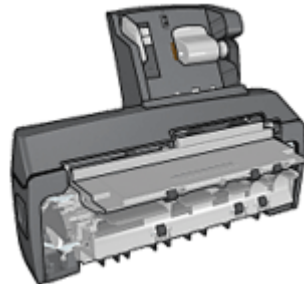

Auto Two-Sided Print
Accessory with Small Paper
Tray

If an accessory is not included with your printer, it can be purchased separately from an authorized HP dealer.

For accessory part numbers, see the [accessory supply list](#).

Note: The availability of accessories varies by country/region.

12.1 Automatic Two-Sided Printing Accessory (duplexer)

The duplexer is a special hardware device that enables the printer to automatically print on both sides of a page.

Using a duplexer with your printer has several advantages. It allows you to do the following tasks:

- Print on both sides of a page without manually reloading the page.
- Use less paper by printing on both sides of paper sheets.
- Create professional-looking brochures, reports, newsletters, and other special items.

If the duplexer is not packaged with your printer, it can be purchased separately from an authorized HP dealer.

Note: The duplexer is not available in all countries/regions.



The duplexer only supports certain paper types. For a list of supported paper types, see the [duplexer specifications](#).

Learn how to [install](#) and [enable](#) the duplexer.

Use the duplexer to print a [two-sided document](#) or [booklet](#) automatically.

Follow these tips to solve [automatic two-sided printing problems](#).

12.1.1 Installing the duplexer

Follow these steps to attach the duplexer to your printer:

1. Push the two latch handles on the printer's rear access door toward each other, and then remove the door.

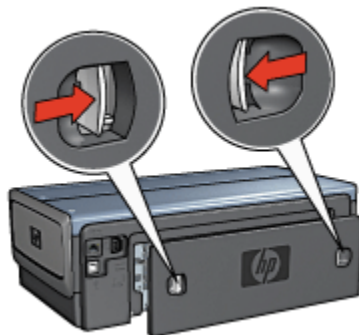

Note: Do not discard the rear access door. In order to print, either the duplexer or the rear access door must be attached to the printer.

2. Insert the duplexer in the back of the printer until both sides snap into place.



Note: Do not press the buttons on either side of the duplexer when installing it in the printer. Use the buttons only when removing the duplexer from the printer.

12.1.2 Printing a booklet automatically

To print a booklet automatically, one of the following accessories must be attached to the printer:



Automatic Two-Sided Printing Accessory



Auto Two-Sided Print Accessory with Small Paper Tray

The two-sided printing accessories only support certain paper types. For a list of supported paper types, see the specifications for either the [Automatic Two-Sided Printing Accessory](#) or the [Auto Two-Sided Print Accessory with Small Paper Tray](#).

If a two-sided printing accessory is not attached to the printer or you are printing on an unsupported paper type, use [manual two-sided printing](#).

Guidelines

Do not exceed the In-tray capacity: up to 150 sheets.

Printing

To print a booklet, follow these steps:

1. Open the **Print** dialog box.
2. Select the **Layout** panel.

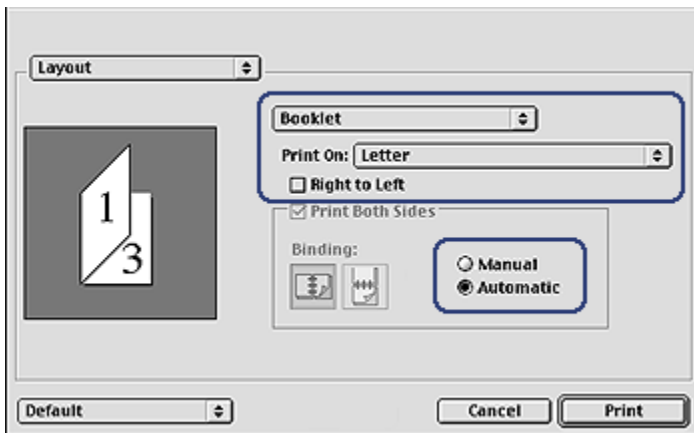

3. In the menu, click **Booklet**.
4. In the **Print On** drop-down list, click the appropriate paper size.
5. If you want the pages to be ordered from right to left, select the **Right to Left** check box.

Note: For most languages, leave the **Right to Left** check box cleared.

6. Select any other printer setting that you want, and then click **Print**.

After the first side of the page is printed, the printer pauses while the ink dries. When the ink is dry, the paper is pulled back into the duplexer and the reverse side of the page is printed.

Note: Do not remove the paper from the printer until both sides of the page have been printed.

12.1.3 Automatic two-sided printing problems

Option for automatic two-sided printing cannot be selected

Verify the following:

- The duplexer is attached to the printer, and the duplexer is **enabled** in **Chooser**.
- A supported paper size is selected in the **Page Setup** dialog box.
- A supported paper type is selected in the **Paper Type/Quality** panel of the **Print** dialog box.

For a list of support paper types and sizes, see the [duplexer specifications](#).

Only one side of the page prints when the two-sided printing option is enabled

Verify the following:

- The photo paper is not curled, if you are printing on two-sided photo paper. Photo paper should be flat before printing. See [storing and handling photo paper](#) for more information.
- The paper size that is selected in the [Page Setup](#) dialog box is supported by the duplexer.
- The paper type that is selected in the **Paper Type/Quality** panel is supported by the [duplexer](#).

If the media type or size is not supported by the duplexer, you can print the document by using the [manual two-sided printing instructions](#).

Binding margin is in the wrong place

You might have chosen an incorrect paper orientation.

1. Open the [Print](#) dialog box.
2. Select the **Layout** panel.
3. Verify that the correct binding has been selected:
 - The **Book** button is selected for binding along the side.
 - The **Tablet** button is selected for binding along the top.

12.1.4 Automatic Two-Sided Printing Accessory specifications

Dimensions when attached to printer

124.6 mm (4.9 in) tall x 320.5 mm (12.62 in) wide x 77.7 mm (3.06 in) deep

Skew (second side of printed page)

Plain paper: +/- .009 mm/mm (.009 in/in)

Cards: +/- .006 mm/mm (.006 in/in)

Envelopes: +/- .012 mm/mm (.012 in/in)

Media weight

Letter/A4: 60 to 90 g/m² (16 to 24 lb)

Cards: Up to 200 g/m² (110 lb index max)

Specialty paper: Up to 160 g/m² (44 lb bond)

Media sizes

Size range: 81 x 117 mm to 216 x 297 mm (3.2 x 4.6 in to 8.5 x 11 in)

Paper:

- U.S. Letter: 216 x 279 mm (8.5 x 11 in)
- Executive: 184 x 267 mm (7.25 x 10.5 in)
- A4: 210 x 297 mm
- A5: 148 x 210 mm
- B5: 182 x 257 mm

Cards:

- 127 x 203 mm (5 x 8 in)
- 102 x 152 mm (4 x 6 in)
- A6: 105 x 148.5 mm
- Hagaki: 100 x 148 mm
- L size: 89 x 127 mm

12.2 250-Sheet Plain Paper Tray Accessory

The 250-Sheet Plain Paper Tray Accessory expands the paper capacity of your printer to 400 sheets. It is useful for high-volume printing and for occasions when you want to use the In tray for special media such as letterhead paper, but still have plain paper readily available.

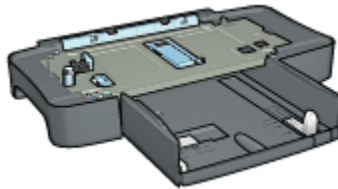

The 250-Sheet Plain Paper Tray Accessory only supports certain paper size. For a list of supported paper sizes, see the [250-Sheet Plain Paper Tray Accessory specifications](#).

If the 250-Sheet Plain Paper Tray Accessory is not included with your printer, it can be purchased separately from an authorized HP dealer.

Note: The 250-sheet Plain Paper Tray Accessory is not available in all countries/regions.

Learn how to [install the 250-Sheet Plain Paper Tray Accessory](#).

Learn how to load paper into the 250-Sheet Plain Paper Tray Accessory.

Use the 250-Sheet Plain Paper Tray Accessory to save time when printing.

12.2.1 Installing the 250-Sheet Plain Paper Tray Accessory

Follow these steps to install the 250-Sheet Plain Paper Tray Accessory:

1. Turn off the printer.
2. Select a location for the printer and place the 250-Sheet Plain Paper Tray Accessory in this location.
3. Carefully lift the printer and orient it above the paper tray.

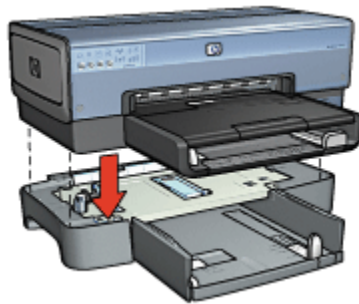

4. Gently place the printer on top of the paper tray.

12.2.2 Loading the 250-Sheet Plain Paper Tray Accessory

Two parts

The 250-Sheet Plain Paper Tray Accessory has two parts.

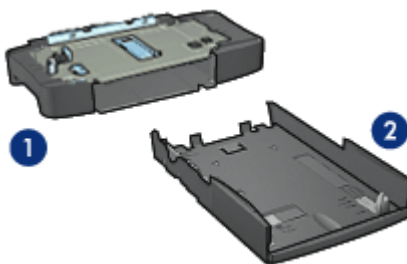

1. Base
2. Lower tray

The lower tray has three size adjusters.

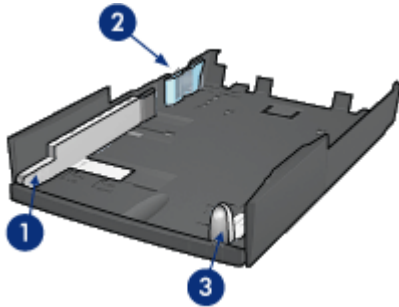

1. Paper-width guide
2. Paper-width fence
3. Paper-length guide

Note: When changing the paper size in the paper tray, you must set all three paper guides.

Setting the paper size

When changing the paper size in the paper tray, all three paper guides must be set to the correct setting.

Follow these steps to set the paper size:

1. Remove the lower tray from the base.

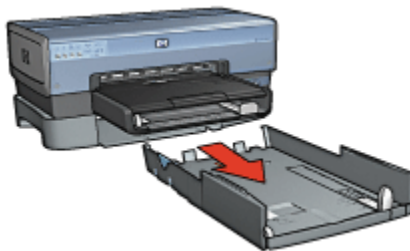

2. Slide the paper-width guide until the arrow is even with the correct setting.



1. Align the arrows

Note: To print on legal-sized paper, set the paper-width guide to **LTR**.

3. Set the paper-width fence by carefully inserting it into the appropriate slots.

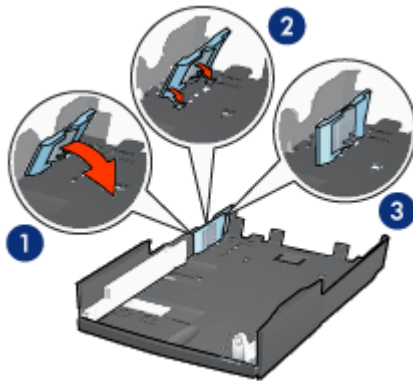

1. Tilt the fence forward.
2. Insert the fence into the appropriate slots
3. Tilt the fence back until it locks into place

Note: To print on legal-sized paper, set the paper-width fence to **LTR**.

4. Set the paper-length guide by pulling it until the arrow lines up with the paper size.

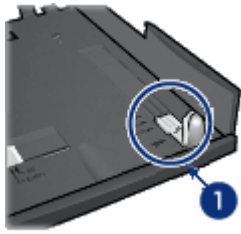

1. Align the arrows

Note: To print on legal-sized paper, pull the paper-length guide all the way out.

Loading paper

Follow these steps to load paper:

1. Remove the lower tray from the base.
2. Verify that **all three paper guides** are set to the correct setting.
3. Insert the paper into the lower tray.



4. Insert the lower tray in the base until it locks into place.

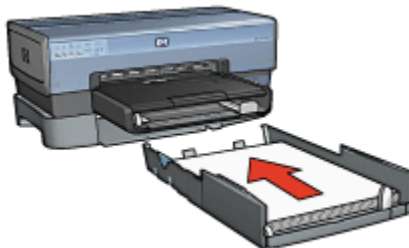

12.2.3 250-Sheet Plain Paper Tray Accessory specifications

Dimensions

448 mm (17.64 in) wide x 65 mm (2.56 in) high x 384 (15.12 in) mm deep

Weight

1.99 kg (4.40 lb)

Media weight

Letter/A4 paper: 60 to 105 g/m² (16 to 28 lbs)

Media sizes

US Letter: 216 x 279 mm (8.5 x 11 in)

Executive: 184 x 267 mm (7.25 x 10.5 in)

A4: 210 x 297 mm

A5: 148 x 210 mm

B5: 182 x 257 mm

12.3 Auto Two-Sided Print Accessory with Small Paper Tray

The Auto Two-Sided Print Accessory with Small Paper Tray is a hardware device that contains a rear tray for small media and a duplexer for two-sided printing on both full-size and small media.

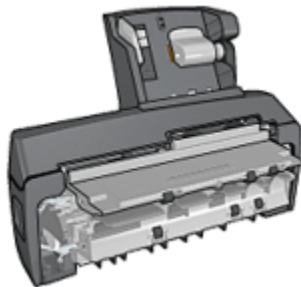

- [Postcards](#) and other small media can be printed on two sides automatically when they are fed from the rear tray.

- [Photo paper](#) and [envelopes](#) can be printed on one side by using the small paper tray.
- Print [two-sided documents automatically](#).

If the Auto Two-Sided Print Accessory with Small Paper Tray is not included with your printer, it can be purchased separately from an authorized HP dealer.

The accessory only supports certain paper types. For a list of supported paper types, see the [Auto Two-Sided Print Accessory with Small Paper Tray specifications](#).

Note: The Auto Two-Sided Print Accessory with Small Paper Tray is not available in all countries/regions.

Learn how to [install](#) and [enable](#) the accessory.

Learn how to [configure the printer to use the accessory when printing from a digital camera](#).

Follow these tips to solve [printing problems](#) when using the accessory.

12.3.1 Installing the Auto Two-Sided Print Accessory with Small Paper Tray

Use these steps to install the Auto Two-Sided Print Accessory with Small Paper Tray:

1. Push the two latch handles on the printer rear access door toward each other, and then remove the door.

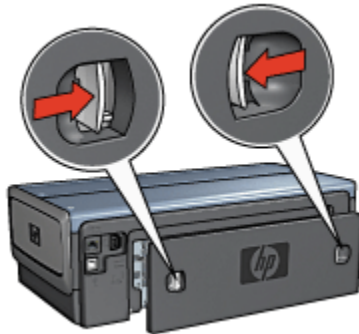

Do not discard the rear access door. In order to print, the accessory or the rear access door must be attached to the printer.

2. Insert the accessory into the back of the printer until both sides snap into place.



Note: Do not press the buttons on either side of the accessory when installing it into the printer. Use the buttons only when removing the accessory from the printer.

12.3.2 Enabling the duplexer

1. Open **Chooser** and select the printer.
2. Click **Setup**.

The **Printer Setup** dialog box appears.

3. Select **Installed** on the **Duplex Unit** menu, then click **OK**.
4. Close **Chooser**.

Note: After the duplexer is enabled, it is not necessary to re-enable it every time you print.

12.3.3 Printing postcards

Guidelines

- Use only cards that meet the specifications for the Auto Two-Sided Print Accessory with Small Paper Tray. For more information, see the [Auto Two-Sided Print Accessory with Small Paper Tray specifications](#).
- When printing a large number of cards, remove the printed material from the printer's Out tray about halfway through the print job.
- Do not exceed the maximum capacity for the rear tray: 100 cards.

Preparing to print

1. Slide the paper-width guide to the left.
2. Pull the paper lever forward and insert the cards.

The address side of the cards should face outward.

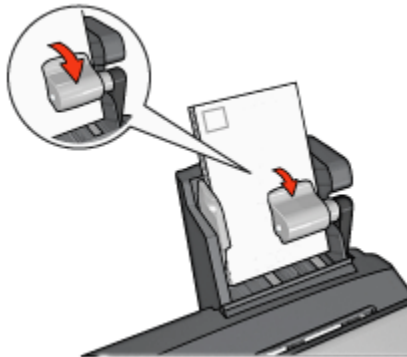

3. Release the paper lever.
4. Slide the paper-width guide against the edge of the cards.

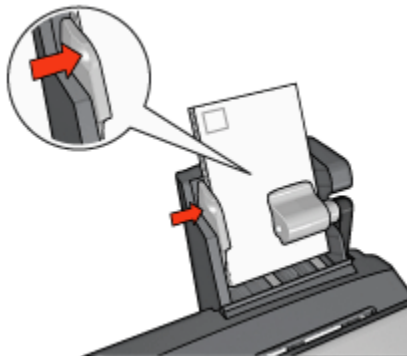

Printing

1. Open the [Page Setup](#) dialog box, and then select the following settings:
 - **Paper Size:** The appropriate paper size

Note: To print a borderless card, click the borderless photo size that matches the card size.

 - **Orientation:** The appropriate orientation
2. Click **OK**.
3. Open the [Print](#) dialog box.
4. Select the **General** panel, and in the **Paper Source** drop-down list, click **Rear Tray**.
5. Select the **Paper Type/Quality** panel, and then select the following settings:

- **Paper Type:** **Plain Paper** or the appropriate paper type
 - **Print Quality:** **Normal**, **Best**, or **Maximum dpi**
6. If you want to use them, set the [HP digital photography options](#).
 7. Select any other print settings that you want, and then click **Print**.

12.3.4 Small photos

Guidelines

- For high-quality results, [use a photo print cartridge](#) in combination with the tri-color print cartridge.
- For maximum fade resistance, use HP Premium Plus Photo Paper and install a photo print cartridge in the printer.
- To learn how to use the photo printing features, see the [photo enhancing](#) page.
- Use [HP Everyday Photo Paper, Semi-gloss](#) to save money and ink when printing photos.
- Verify that the photo paper that you are using is flat. For information about preventing photo paper from curling, see the [photo paper storage instructions](#).
- Do not exceed the maximum capacity of the rear tray: 80 sheets of photo paper.

Preparing to print

1. Slide the paper-width guide to the left.
2. Pull the paper lever forward and insert the photo paper.

The side of the photo paper to be printed on should face outward.

Note: If the photo paper has a tear-off tab, the tab must point up rather than leading into the printer.

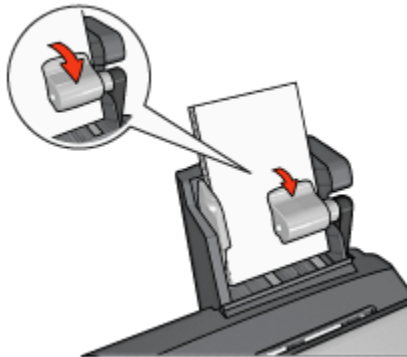

3. Release the paper lever.
4. Slide the paper-width guide against the edge of the photo paper.

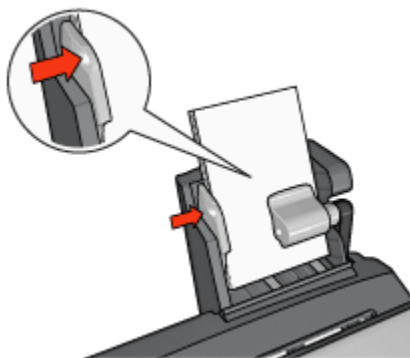

Printing

1. Open the [Page Setup](#) dialog box, and then select the following settings:
 - **Paper Size:** The appropriate paper size

Note: To print a borderless photo, select a borderless photo paper size.

 - **Orientation:** The appropriate orientation
2. Click **OK**.
3. Open the [Print](#) dialog box.
4. Select the **General** panel, and in the **Paper Source** drop-down list, click **Rear tray**.
5. Select the **Paper Type/Quality** panel, and then select the following settings:
 - **Paper Type:** The appropriate photo paper type
 - **Print Quality:** **Best** or **Maximum dpi**
6. If you want to use them, set the [HP digital photography options](#).
7. Select any other print settings that you want, and then click **Print**.

12.3.5 Envelopes

Guidelines

- Avoid using envelopes that have the following qualities:
 - Have clasps or windows
 - Have thick, irregular, or curled edges

- Are shiny or embossed
- Are wrinkled, torn, or otherwise damaged
- Align the envelope edges before inserting them in the rear tray.
- Do not exceed the maximum capacity of the rear tray capacity: 80 envelopes.

Preparing to print

1. Slide the paper-width guide to the left.
2. Pull the paper lever forward and insert the envelopes.

Insert the envelopes with the address side facing outward and the flap to the left.

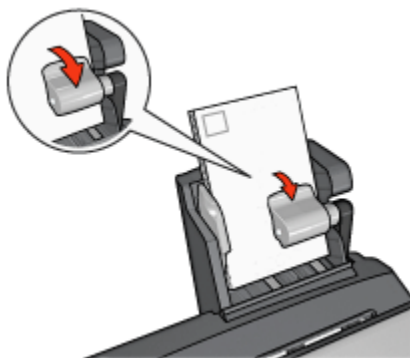

3. Release the paper lever.
4. Slide the paper-width guide against the edge of the envelopes.

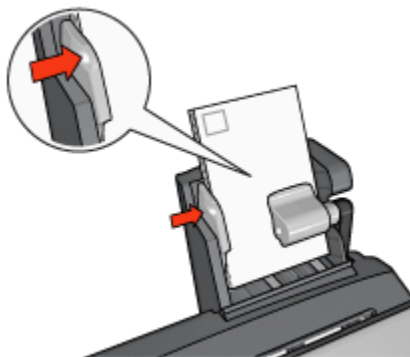

Printing

1. If necessary, open the [Page Setup](#) dialog box and set the paper size, scaling, or orientation options.

2. Open the **Print** dialog box.
3. Select the **Paper Type/Quality** panel.
4. In the **Paper Type** drop-down list, click **Plain paper**.
5. Select any other print settings that you want, and then click **Print**.

12.3.6 Problems with the Auto Two-Sided Print Accessory with Small Paper Tray

Paper jam

Do **not** clear a paper jam from the front of the printer.

Follow these steps to remove a paper jam from the Auto Two-Sided Print Accessory with Small Paper Tray.

1. Turn off the printer.
2. Press the buttons on the left and right sides of the accessory, and then remove it from the printer.

 **Warning:** Remove the Auto Two-Sided Print Accessory with Small Paper Tray before opening it when clearing a paper jam.

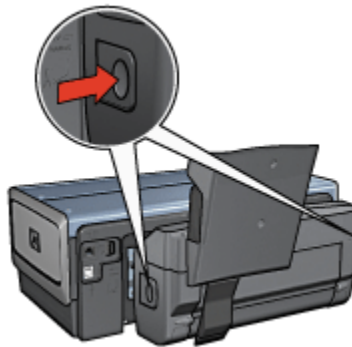

3. Remove any paper that is inside the printer.
4. Lift the back lever on the accessory, and then unhook the Small Paper Tray.

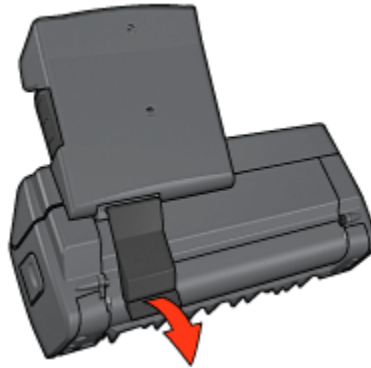

5. Tilt the Small Paper Tray forward and open the lower door of the accessory.

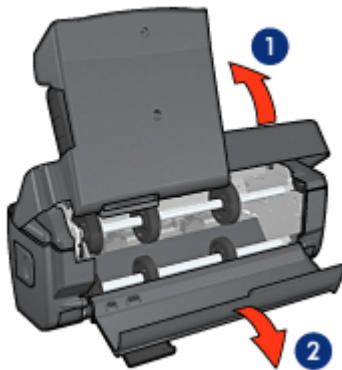

1. Tilt the Small Paper Tray
2. Open the lower door

6. Remove any paper that is inside the accessory.
7. Close the accessory, and then secure the back lever to close the accessory.
8. Re-attach the accessory to the printer.



Option for automatic two-sided printing cannot be selected

Verify the following:

- The duplexer is attached to the printer, and the duplexer is **enabled** in **Chooser**.
- A supported paper size is selected in the **Page Setup** dialog box.
- A supported paper type is selected in the **Paper Type/Quality** panel of the **Print** dialog box.

For a list of support paper types and sizes, see the [duplexer specifications](#).

Paper size changes when the two-sided printing option is selected

The paper size is not supported by the [duplexer](#).

Binding margin is in the wrong place

You might have chosen an incorrect paper orientation.

1. Open the [Print](#) dialog box.
2. Select the **Layout** panel.
3. Verify that the correct binding has been selected:
 - The **Book** button is selected for binding along the side.
 - The **Tablet** button is selected for binding along the top.

Only one side of the page prints when the two-sided printing option is enabled

Verify the following:

- The photo paper is not curled, if you are printing on two-sided photo paper. Photo paper should be flat before printing. See [storing and handling photo paper](#) for more information.
- The paper size that is selected in the [Page Setup](#) dialog box is supported by the duplexer.
- The paper type that is selected in the **Paper Type/Quality** panel is supported by the [duplexer](#).

If the media type or size is not supported by the duplexer, you can print the document by using the [manual two-sided printing instructions](#).

Colors look faded

If the colors look faded, try printing the two-sided document by using the [manual two-sided printing instructions](#).

12.3.7 Auto Two-Sided Print Accessory with Small Paper Tray specifications

Dimensions when attached to printer

219.3 mm (8.63 in) tall x 320.5 mm (12.62 in) wide x 142.1 mm (5.6 in) deep

Duplexing specifications

For duplexing specifications, including skew, media weight, and media sizes for paper fed into the printer through the printer In tray, see the [Automatic Two-Sided Printing Accessory specifications](#).

Small paper tray specifications

Media thickness: 7-12 mils

Media sizes:

- Size range:
 - Width: 81.3 to 106 mm (3.2 to 4.17 in)
 - Length: 116.8 to 304.8 mm (4.6 to 12 in)
- Cards:
 - 10x15 cm, 10x15 cm with tab
 - 4x6 in, 4x6 in with tab
 - A6, 105x148 mm
 - Index card, 4x6 in.
 - L, 89x127 mm
- Photo paper:
 - 10x15 cm, 10x15 cm with tab
 - 4x6 in, 4x6 in. with tab
 - A6, 105x148 mm
 - L, 89x127 mm, L, 89x127 mm with tab
 - Panoramic 4x10 in, 4x11 in, 4x12 in
- Envelopes:
 - No. 10 Envelope, 4.12x9.5 in
 - Japanese envelope No. 4, 90x205 mm
- Hagaki:
 - Hagaki, 100x148 mm

Tray capacities:

HP Deskjet 6800 series printer User's Guide

- Photo paper:
 - 4x6, L size: Up to 80 sheets
 - Panoramic: Up to 5 sheets
- Hagaki:
 - Photo: Up to 80 cards
- Cards:
 - 4x6: Up to 100
 - A6: Up to 100
- Envelopes:
 - No. 10: Up to 20
 - Japanese envelope No. 4: Up to 20

13 Specifications

- [Printer specifications](#)
- [Environmental statement](#)
- [Print cartridge recovery](#)

13.1 Printer specifications

See the reference guide that came with your printer for complete printer specifications, including the following information:

- Types, sizes, and weights of paper and other printing media that can be used with your printer
- Print speeds and resolutions
- Power requirements

13.2 Environmental statement

Hewlett-Packard continuously improves the design processes of its deskjet printers to minimize the negative impact on the office environment and on the communities where printers are manufactured, shipped, and used.

Reduction and elimination

Paper use: The printer's [two-sided printing](#) capability reduces paper usage and the resulting demands on natural resources. In addition, the [print cancel button](#) allows the user to save paper by quickly canceling a print job as needed. Finally, this equipment is suitable for using recycled paper (in accordance with EN 12281:2002).

Recycled paper: All paper documentation for this printer is printed on recycled paper.

Ozone: Ozone-depleting chemicals such as CFCs have been eliminated from Hewlett-Packard's manufacturing processes.

Recycling

Design for recycling has been incorporated into this printer. The number of materials has been kept to a minimum while ensuring proper functionality and reliability. Dissimilar materials have been designed to separate easily. Fasteners and other connections are easy to locate, access, and remove using common tools. High-priority parts have been designed to gain access to quickly for efficient disassembly and repair.

Printer packaging: The packaging materials for this printer have been selected to provide maximum protection for the least cost possible, while attempting to minimize environmental impact and facilitate recycling. The rugged design of the HP Deskjet printer assists in minimizing both packaging materials and damage rates.

Plastic parts: All major plastics and plastic parts are marked according to international standards. All plastic parts used in the printer housing and chassis are technically recyclable and all use a single polymer.

Product longevity: To ensure the longevity of your HP Deskjet printer, HP provides the following:

- **Extended warranty:** Details can be found in the reference guide that came with your printer.
- **Product take-back:** To return this product to HP at the end of its useful life, go to www.hp.com/recycle. To return empty print cartridges to HP, see [print cartridge recovery](#).

Note: The extended warranty and product take-back options are not available in all countries/regions.

Energy consumption

Energy consumption in off-mode: When the printer is off, an amount of energy is still being consumed. Energy consumption can be prevented by turning the printer power off, then disconnecting the end of the printer power cord from the electrical source.

13.3 Print cartridge recovery

Customers interested in recycling their genuine HP print cartridges can participate in HP's Planet Partner's Program for inkjet cartridges. HP offers this program in more countries/regions than any other inkjet cartridge manufacturer in the world. This program is provided as a free service to HP customers as an environmentally sound solution for these products at end-of-life.

To participate, simply follow the directions provided on the HP Web site at this address: www.hp.com/recycle. This service is not available in all countries/regions. Customers may be asked for their name, phone number, and address.

Because HP's unique recycling processes are very sensitive to material contamination, we cannot take back and recycle cartridges from other manufacturers. The end products of the recycling process are used in the manufacture of new products, and HP must ensure the composition of the material is consistent. To do that, we recycle only HP original cartridges. This program does not extend to refilled cartridges.

Returned cartridges are separated for purification into raw materials for use in other industries to manufacture new products. Examples of products made from recycled HP print cartridge materials include automobile parts, trays used in microchip fabrication processes, copper wire, steel plates, and the precious materials used in electronics. Depending on the model, HP is able to recycle up to 65% of the print cartridge by weight. The remaining parts that cannot be recycled (ink, foam, and composite parts) are disposed of in an environmentally responsible manner.

14 Supplies

- [Paper](#)
- [USB cables](#)
- [Accessories](#)
- [Print cartridges](#)

Note: The availability of supplies and accessories varies by country/region.

14.1 Paper

To order media such as HP Premium Paper, HP Premium Inkjet Transparency Film, HP Iron-On Paper, or HP Greeting Cards, go to www.hp.com.

Choose your country/region, and then select **Buy** or **Shopping**.

14.2 USB cables

Note: The availability of supplies varies by country/region.

C6518A HP USB A-B 2 M cable

14.3 Accessories

If an accessory is not included with your printer, it can be purchased separately from an authorized HP dealer.

Note: The availability of accessories varies by country/region.

Automatic Two-Sided Printing Accessory

Q5712A Automatic Two-Sided Printing Accessory

Auto Two-Sided Print Accessory with Small Paper Tray

Q3032A Auto Two-Sided Print Accessory with Small Paper Tray

250-Sheet Plain Paper Tray Accessory

Q3447A 250-Sheet Plain Paper Tray Accessory

Index

A

- acknowledgements
- ad hoc mode
- AES
- Align button
- aligning print cartridges
- authentication
- Auto Two-Sided Print Accessory with Small Paper Tray
 - booklet
 - envelopes
 - installation
 - paper jam
 - part number
 - printing from a digital camera
 - printing problems
 - small photos
- Automatic Paper-Type Sensor
- Automatic Two-Sided Printing Accessory
 - booklet
 - installation
 - part number

B

- borderless photos
 - large borderless photos
 - panoramic borderless photos
 - small borderless photos
- borderless photos
- borderless printing
 - problems
- buttons
 - Cancel
 - Power
 - Print Cancel

Report Page

Resume

C

collated copies

color calibration

color settings

communication modes

ad hoc mode

infrastructure mode

connectivity

Ethernet

Wi-Fi networking

wireless networking

contrast enhancement

conventions

D

default printer, setting

digital flash

duplexer

E

embedded Web server (EWS)

encryption

energy consumption

envelope is printed at an angle

environmental statement

error messages

Ethernet

basics

connecting the printer to a network

embedded Web server (EWS)

Ethernet cable

factory default settings

hardware

HP Report page

installing the printer software

- lights
- network examples
- networking glossary
- printing on an Ethernet network

G

- gray photo print cartridge

H

- HP digital photography options
- HP Inkjet Toolbox
- HP Report page

I

- In tray
- infrastructure mode
- ink-backup mode
- ink, removing ink from skin and clothing
- installing print cartridges

L

- lights
 - are flashing
 - Ethernet lights
 - Network icon
 - Power
 - Print Cartridge Status lights
 - Resume

M

- maximum dpi
- mirror image

N

- Network icon
- network locations
- network name (SSID)

- networking glossary
- notices

O

- optional 250-Sheet Plain Paper Tray Accessory
 - installation
 - loading
 - part number
 - specifications
 - using
- orientation
- Out tray

P

- paper jam
- paper supplies
- paper trays
- photo print cartridge
- Photo/envelope feeder
- photos
 - 4800 x 1200 optimized dpi printing
 - black-and-white
 - borderless
 - color settings
 - digital
 - enhancing
 - maximum dpi
 - printing problems
 - storing photo paper
- photos, printing
 - large borderless photos
 - large photos with a white border
 - panoramic borderless photos
 - panoramic photos with a white border
 - small borderless photos
 - small photos with a white border
- PictBridge
 - lights flashing

- photos are not printing
- printing
- printing from the Auto Two-Sided Print Accessory with Small Paper Tray
- Print Cartridge Status lights
- print cartridges
 - align
 - black print cartridge
 - cleaning automatically
 - cleaning manually
 - gray photo print cartridge
 - installing
 - maintaining
 - photo print cartridge
 - recovery
 - recycling
 - replacing
 - storing
 - tri-color print cartridge
- print job status
- print order
- print quality
- print settings
- printer
 - does not reflect new print settings
 - is slow
- printer body
- printer features
 - Automatic Paper-Type Sensor
 - ink-backup mode
- printer status
- printing
 - booklets, printing with duplexer
 - brochure, borderless
 - multiple pages on single sheet
 - paper source, selecting
 - selecting a paper type
 - two-sided printing, automatic
 - two-sided printing, manual

R

- recycling
 - print cartridges
- removing ink from skin and clothing
- Report Page button
- resizing documents
- rotate 180 degrees

S

- scaling
- setting printer as default printer
- sharpness
- SmartFocus
- smoothing
- status of print job

T

- terms
- TKIP
- troubleshooting
 - blank pages print
 - document prints slowly
 - error messages
 - paper jam
 - parts of the document are printed in the wrong place
 - parts of the document are missing
 - photos are not printing correctly
 - print is faded
 - printer is not printing
 - printer prints on multiple sheets at once
 - printer will not feed paper
 - printout does not reflect new print settings
 - streaks and missing lines
 - text and images are misaligned
 - too little ink appears on the page
 - too much ink appears on the page
- two-sided printing
 - manual

U

USB

- cable part number

W

WEP

Wi-Fi networking

wi-fi 802.11b networking

- basics

- explanation

- network locations

- printing on a Wi-Fi network

wi-fi networking

- communication modes

- embedded Web server (EWS)

- factory default settings

- HP Report page

- installing the printer on a network

- network examples

- network name (SSID)

- networking glossary

- open system

- status light

WEP

- wireless radio

- wireless security

WPA

wireless networking

- basics

- communication modes

- embedded Web server (EWS)

- factory default settings

- HP Report page

- installing the printer on a network

- network examples

- network locations

- network name (SSID)

- networking glossary

- printing on a wireless network
- status light
- Wi-Fi
- wireless radio
- wireless security
 - authentication
 - encryption
 - open system
 - WEP
 - WPA
- WPA