



Hardware and Software Guide

HP Notebook Series

Document Part Number: 375382-001

March 2005

This guide explains how to identify and use most of the hardware and software features, including optional wireless features, available on your notebook. For additional notebook information, including troubleshooting information, refer to the Help and Support Center at Start > Help and Support. If your model includes a wireless device, wireless setup information is provided in a printed *Go Wireless* booklet. Additional 802.11 information is included within 802.11 software.

© Copyright 2005 Hewlett-Packard Development Company, L.P.

Microsoft and Windows are U.S. registered trademarks of Microsoft Corporation. SD Logo is a trademark of its proprietor. Bluetooth is a trademark owned by its proprietor and used by Hewlett-Packard Company under license.

The information contained herein is subject to change without notice. The only warranties for HP products and services are set forth in the express warranty statements accompanying such products and services. Nothing herein should be construed as constituting an additional warranty. HP shall not be liable for technical or editorial errors or omissions contained herein.

Hardware and Software Guide
HP Notebook Series
First Edition March 2005
Reference Number: zv6000
Document Part Number: 375382-001

Contents

1 Component ID

Top Components	1-1
Keyboard and Digital Media Slot Lights	1-1
Power/Standby, Drive and Battery Lights	1-2
TouchPad	1-3
Power Controls	1-4
Speakers and Quick Launch Buttons	1-5
Wireless Button and Light	1-6
Keys	1-7
Front Components	1-8
Rear Components	1-9
Right-Side Components	1-10
Ports	1-10
Jacks and Vent	1-11
Left-Side Components	1-12
External Card Features	1-12
Security Cable Slot, Ports and Bays	1-13
Bottom Components	1-14
Bays and Vents	1-14
Expansion Memory Module Compartment	1-15
Wireless Antennae	1-16
Additional Hardware Components	1-17
Power and Modem Hardware	1-17
Optical Discs	1-18
Labels	1-19

2 Power

Power Control and Light Locations	2-1
Power Sources	2-3
Selecting a Power Source	2-3
Using External or Battery Power.	2-4
Standby and Hibernation	2-5
Standby	2-5
Hibernation	2-6
Initiating Standby, Hibernation or Shutdown	2-8
Default Power Settings.	2-9
Turning the Notebook or Display On or Off.	2-10
Initiating or Restoring from Hibernation.	2-11
Initiating or Resuming from Standby	2-12
Using Emergency Shutdown Procedures	2-13
Power Options	2-13
Accessing the Power Options Window	2-13
Displaying the Power Meter Icon	2-14
Setting or Changing a Power Scheme	2-15
Using a Security Password	2-16
Battery Packs	2-17
Inserting or Removing a Battery Pack.	2-17
Charging Battery Packs	2-19
Monitoring the Charge in a Battery Pack	2-20
Managing Low-Battery Conditions.	2-21
Calibrating a Battery Pack.	2-24
Conserving Battery Power.	2-28
Storing a Battery Pack	2-29
Disposing of a Used Battery Pack.	2-30

3 Keyboard

TouchPad	3-1
Using the TouchPad.	3-1
Setting Mouse Properties.	3-3
Hotkeys	3-4
Hotkey Quick Reference	3-4
Using Hotkey Procedures	3-5
Using Hotkey Commands	3-5
Using Hotkeys with External Keyboards	3-11
Quick Launch Buttons	3-12
Identifying Quick Launch Buttons	3-12
Quick Launch Buttons Software	3-13
Keypads	3-17
Using the Embedded Numeric Keypad	3-18
Using an External Numeric Keypad	3-20

4 Multimedia

Audio Features	4-1
Using the Audio-In (Microphone) Jack.	4-1
Using the Audio-Out (Headphone) Jack	4-2
Adjusting the Volume	4-3
Video Features	4-4
Using the S-Video-Jack.	4-4
Connecting a Monitor, Projector or Television.	4-6
Changing the Video Display	4-8
Multimedia Software	4-9
Finding Included Multimedia Applications.	4-9
Selecting Multimedia Applications	4-9
Using Default Applications	4-10
Installing Multimedia Applications.	4-12
Using Multimedia Applications.	4-14
Setting AutoPlay Preferences	4-17
Changing DVD Region Settings	4-18

5 Drives

Drive Care	5-1
IDE Drive Light	5-2
Primary Hard Drive	5-2
Optical Drive	5-3
Inserting an Optical Disc	5-3
Removing an Optical Disc (With Power)	5-4
Removing an Optical Disc (Without Power).	5-5
Displaying Optical Disc Contents	5-6
Avoiding Standby or Hibernation	5-6

6 PC Cards and ExpressCards

What Is a PC Card?	6-1
Inserting a PC Card	6-2
Stopping or Removing a PC Card	6-4
What Is an ExpressCard?	6-5
Selecting an ExpressCard	6-5
Configuring an ExpressCard	6-6
Inserting an ExpressCard.	6-6
Stopping or Removing an ExpressCard.	6-8

7 Digital Memory Cards

What Is a Digital Memory Card?	7-1
Using the Digital Media Slot Light	7-2
Insertion	7-3
Removal	7-4

8 Memory Modules

What Is a Memory Module?	8-1
Primary Memory Module Slot	8-1
Expansion Memory Module Slot	8-1
Selecting a Memory Module	8-2
Removing or Inserting a Memory Module	8-2
Hibernation File	8-7
Video Memory Settings	8-7

9 USB and 1394 Devices

What Is USB?.	9-1
USB Device Connection	9-2
What Is 1394?	9-3
1394 Device Connection	9-3

10 Modem and Networking

Internal Modem	10-1
Modem Cable	10-1
Modem Country Selection	10-5
Preinstalled Communication Software	10-9
Network	10-10
Network Cable	10-10
Using the Network Cable	10-11

11 Wireless (Select Models Only)

Wireless Local Area Network (Select Models Only) . .	11-3
Setting Up a WLAN in Your Home	11-4
Using a WLAN Connection	11-5
Using Wireless Security Features	11-6
Installing Wireless Software (Optional)	11-6
Accessing WLAN Software and Documentation . .	11-7
Troubleshooting Devices	11-8

Bluetooth (Select Models Only)	11–9
Device Power States	11–11
Turning On the Devices	11–13
Turning Off and Disabling the Devices	11–14

12 Security

Security Features	12–1
Security Preferences in the Setup Utility	12–3
QuickLock	12–3
Passwords	12–5
HP and Windows Passwords	12–5
HP and Windows Password Guidelines	12–7
HP Administrator Passwords	12–9
Setting HP Administrator Passwords	12–10
Entering HP Administrator Passwords	12–11
Power-On Passwords	12–11
Setting Power-On Passwords	12–11
Entering Power-On Passwords	12–12
DriveLock	12–13
Setting DriveLock Passwords	12–14
Entering DriveLock Passwords	12–15
Changing DriveLock Passwords	12–16
Removing DriveLock Protection	12–17
Device Security	12–18
Antivirus Software	12–19
Critical Security Updates for Windows XP	12–20
Firewall Software	12–21
Optional Security Cable	12–22

13 Setup Utility

Open the Setup Utility	13–2
Setup Utility Language	13–3
Navigation and Item Selection	13–4

System Information	13–4
Default Settings	13–5
Advanced Features	13–6
Close the Setup Utility	13–7

14 Software Updates and Recovery

Software Updates	14–1
Accessing Notebook Product Information	14–2
Accessing Notebook ROM Information	14–2
Internet Software	14–4
Downloading System ROM	14–4
Downloading Software	14–7
System Recovery	14–8
Before You Begin	14–9
Safeguarding Your Data	14–9
Using System Restore	14–10
Repairing or Reinstalling Drivers	14–11
Repairing or Reinstalling Applications	14–12
Repairing the Operating System	14–14
Reinstalling the Operating System	14–15

15 Notebook Care

Temperature	15–1
Notebook	15–1
Keyboard	15–3
Display	15–4
TouchPad	15–4
External Mouse	15–4

16 Travel and Shipping

Travel	16–1
Shipping	16–2

17 Specifications

Operating Environment	17-1
Rated Input Power	17-2
Expansion Port 2 Input/Output Signals	17-3

Index

1

Component ID

Top Components

Keyboard and Digital Media Slot Lights



Component	Description
❶ Caps lock light	On: Caps lock is on.
❷ Digital Media Slot light (select models only)	On: A digital memory card is being accessed. (This light is also visible from the left side of the notebook.)
❸ Num lock light	On: Num lock is on or the embedded numeric keypad is enabled.

Power/Standby, Drive and Battery Lights



Component	Description
1 Power/standby lights (2)*	On: Notebook is turned on. Blinking: Notebook is in standby. Off: Notebook is off.
2 IDE (Integrated Drive Electronics) drive light	On or blinking: The primary hard drive or an optical drive is being accessed.
3 Battery light	On: The battery pack is charging. Blinking: The notebook is unable to start up while running on the available battery power. [†] Off: The battery pack is fully charged or not inserted.

*The notebook has 2 power/standby lights. The power/standby light on the top of the notebook is visible only when the notebook is open; the power/standby light on the front of the notebook is visible when the notebook is closed.

[†]The battery light blinks if you try to turn on the notebook while the notebook is disconnected from external power and contains a battery pack that does not have enough charge to start the notebook.

TouchPad

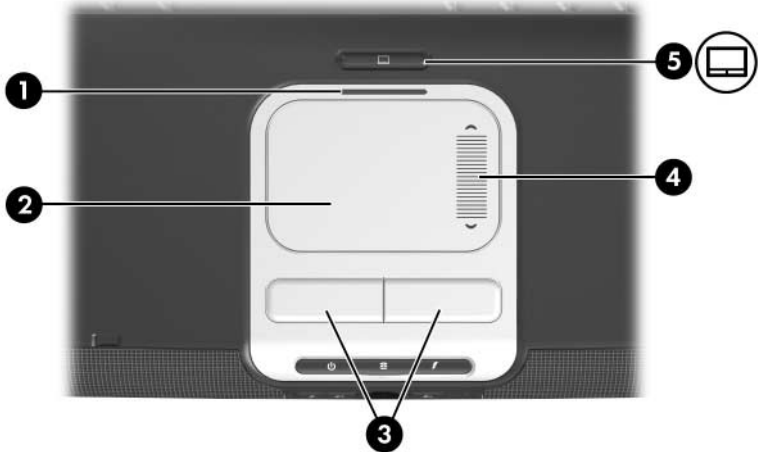

Component	Description
❶ TouchPad light	On: TouchPad is enabled.
❷ TouchPad*	Moves the pointer.
❸ Left and right TouchPad buttons*	Function like the left and right buttons on an external mouse.
❹ TouchPad vertical scroll zone*	Scrolls upward or downward.
❺ TouchPad button	Enables/disables the TouchPad.

*This table describes default settings. For information about changing the functions of TouchPad components, refer to [“Setting Mouse Properties”](#) in [Chapter 3, “Keyboard.”](#)

Power Controls



Component	Description
1 Power button*	<p>When the notebook is</p> <ul style="list-style-type: none"> ■ Off, press to turn on the notebook. ■ On, briefly press to initiate hibernation. ■ In standby, briefly press to resume from standby. ■ In hibernation, briefly press to restore from hibernation. <p> If the system has stopped responding and Microsoft® Windows® shutdown procedures cannot be used, press and hold for at least 4 seconds to turn off the notebook.</p>
2 Display switch*	<p>Initiates standby if the notebook is closed while on.</p>

*This table describes default settings. For information about changing the function of the display switch or power button, refer to [“Accessing the Power Options Window”](#) in [Chapter 2, “Power.”](#)

Speakers and Quick Launch Buttons



Component	Description
❶ DVD button*	Opens the default DVD application.
❷ Music button*	Opens the default music application.
❸ Internet button	Opens the default Web browser. The factory default Web browser is Microsoft Internet Explorer.
❹ Stereo speakers (2)	Produce stereo sound.

*This table describes default settings. The function of the DVD button and the music button can be changed. For instructions, refer to [“Setting DVD and Music Button Preferences”](#) in [Chapter 3, “Keyboard.”](#)

Wireless Button and Light

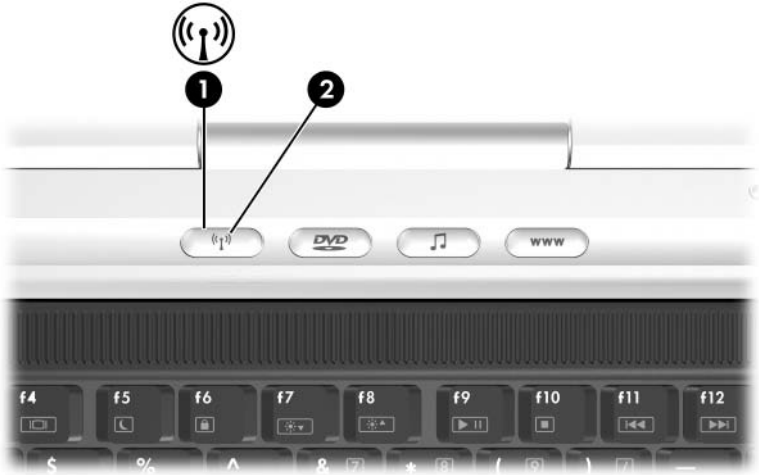

Component	Description
① Wireless button (select models only)	Turns the wireless functionality on or off, but does not create a wireless connection.*
② Wireless light (select models only)	On: One or more optional internal wireless devices, such as an 802.11 wireless device and/or a Bluetooth® device, are turned on. (This light does not indicate whether a wireless connection has been established.)*

*To establish a wireless connection, a wireless network must already be set up. For information about establishing a wireless connection, refer to the printed *Go Wireless* brochure included with your notebook and to [Chapter 11, “Wireless \(Select Models Only\).”](#)

Keys

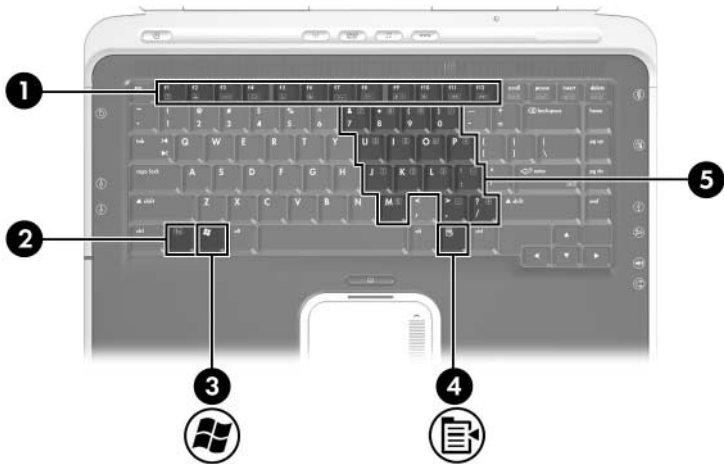

Component	Description
❶ Function keys (12)	Perform system and application tasks. When combined with fn , the function keys perform additional tasks as hotkeys.
❷ fn key	Combines with other keys to perform system tasks. For example, pressing fn+f7 decreases screen brightness.
❸ Windows logo key	Displays the Windows Start menu.
❹ Windows applications key	Displays a shortcut menu for items beneath the pointer.
❺ Embedded numeric keypad keys (15)	Can be used like the keys on an external numeric keypad.

Front Components

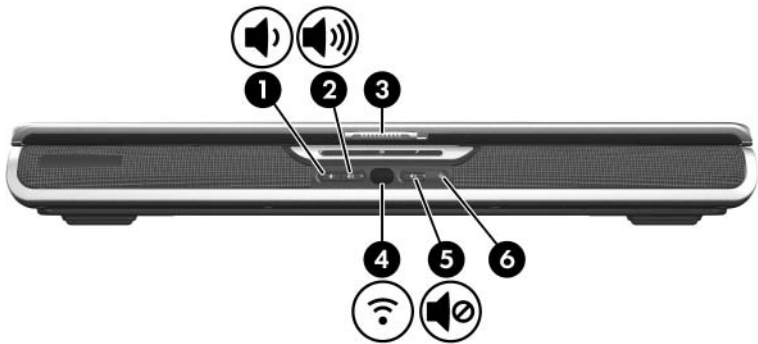

Component	Description
① Volume down button	Decreases system volume.
② Volume up button	Increases system volume.
③ Display release latch	Opens the notebook.
④ Consumer infrared lens (select models only)	Links the notebook to an optional remote control.
⑤ Volume mute button	Mutes or restores volume.
⑥ Mute light	On: Volume is muted.

Rear Components

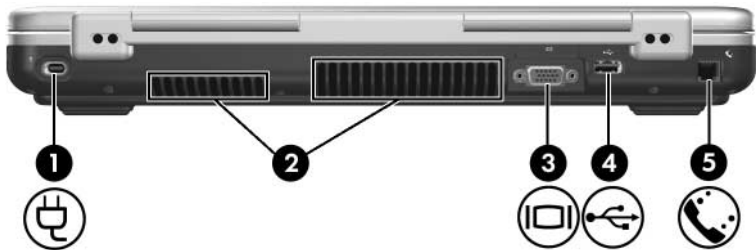

Component	Description
❶ Power connector	Connects the AC adapter cable.
❷ Exhaust vents (2)*	<p>Provides airflow to cool internal components.</p> <p>⚠ To prevent overheating, do not obstruct vents. Do not allow a hard surface, such as a printer, or a soft surface, such as pillows or thick rugs or clothing, to block airflow.</p>
❸ External monitor port	Connects an optional VGA monitor or projector.
❹ USB port†	Connects an optional USB device.
❺ RJ-11 (modem) jack	Connects the modem cable.

*The notebook has 5 vents. Another one of these vents is visible on the right side of the notebook. All vents are visible on the bottom of the notebook.

†The notebook has 4 USB ports. The other USB ports are on the right side and the left side of the notebook.

Right-Side Components

Ports

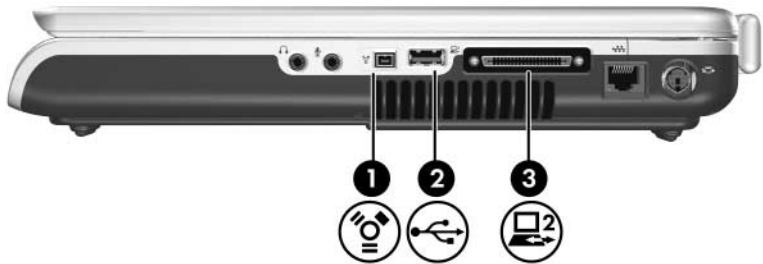

Component	Description
❶ 1394 port (select models only)	Connects an optional 1394a device such as a scanner, a digital camera, or a digital camcorder.
❷ USB port*	Connects an optional USB device.
❸ Expansion port 2 [†]	Connects the notebook to an optional docking device.

*The notebook has 4 USB ports. The other USB ports are on the left side and the rear of the notebook.

[†]The notebook has only one expansion port. The term *expansion port 2* describes the type of expansion port. For expansion port signal information, refer to “[Expansion Port 2 Input/Output Signals](#)” in [Chapter 17](#), “[Specifications](#).”

Jacks and Vent

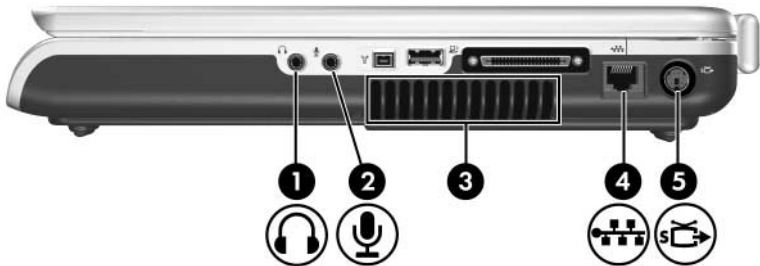

Component	Description
① Audio-out (headphone) jack	Connects optional headphones or powered stereo speakers. Also connects the audio function of an audio/video device such as a television or VCR.
② Audio-in (microphone) jack	Connects an optional monaural (single sound channel) microphone.
③ Exhaust vent*	Provides airflow to cool internal components. △ To prevent overheating, do not obstruct vents. Do not allow a hard surface, such as a printer, or a soft surface, such as pillows or thick rugs or clothing, to block airflow.
④ RJ-45 (network) jack	Connects an optional network cable.
⑤ S-Video-out jack	Connects an optional S-Video device, such as a television, VCR, camcorder, projector, or video capture card.

*The notebook has 5 vents. Two of these vents are visible on the rear of the notebook. All vents are visible on the bottom of the notebook.

Left-Side Components

External Card Features

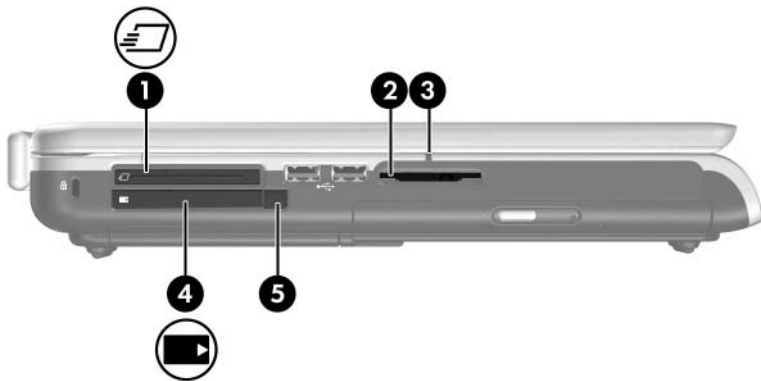

Component	Description
① ExpressCard slot (select models only)	Supports an optional ExpressCard.
② Digital Media Slot (select models only)	Supports an optional digital memory card.*
③ Digital Media Slot light (select models only)	On: An optional digital memory card is being accessed.*
④ PC Card slot	<ul style="list-style-type: none"> ■ Supports an optional Type I or Type II 32-bit (CardBus) or 16-bit PC Card. ■ Stores an optional remote control.
⑤ PC Card eject button	Ejects an optional PC Card from the PC Card slot.

*The slot supports most digital memory cards. For example, you could use a Secure Digital (SD) Memory Card, Memory Stick, Memory Stick Pro, xD-Picture Card, MultiMediaCard, or SmartMedia (SM) card.

Security Cable Slot, Ports and Bays

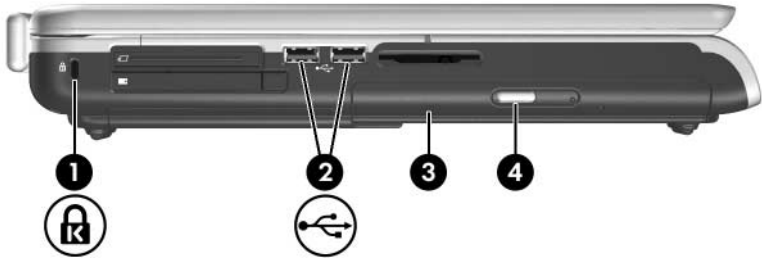

Component	Description
❶ Security cable slot	Attaches an optional security cable to the notebook.  Security solutions are designed to act as deterrents. These deterrents may not prevent a product from being mishandled or stolen.
❷ USB ports (2)*	Connect an optional USB device.
❸ Optical drive [†]	Supports an optical disc.
❹ Optical drive release button	Opens the media tray of the optical drive when power is available.

*The notebook has 4 USB ports. The other USB ports are on the right side and the rear of the notebook.

[†]The type of optical drive—for example, a DVD-ROM drive, a DVD/CD-RW Combo Drive, or a DVD±RW and CD-RW Combo Drive—varies by notebook model.

Bottom Components

Bays and Vents

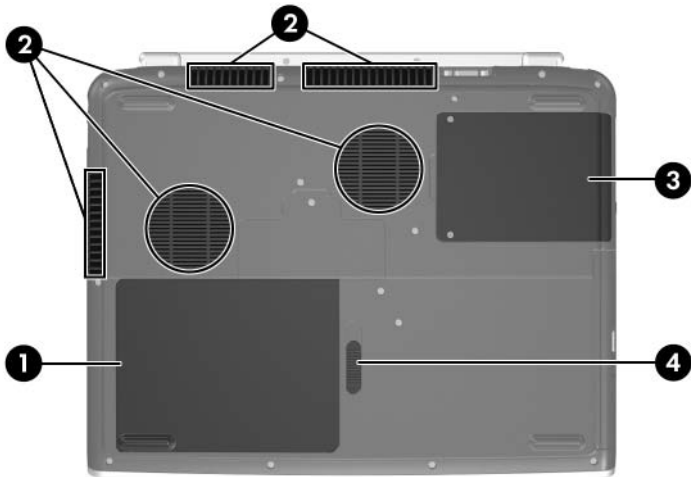

Component	Description
① Battery bay	Holds a battery pack.*
② Exhaust vents (5)	Provide airflow to cool internal components. △ To prevent overheating, do not obstruct vents. Do not allow a hard surface, such as a printer, or a soft surface, such as pillows or thick rugs or clothing, to block airflow.
③ Hard drive bay	Holds the primary hard drive.
④ Battery pack release latch	Releases a battery pack from the battery bay.

*Battery packs vary by notebook model.

Expansion Memory Module Compartment

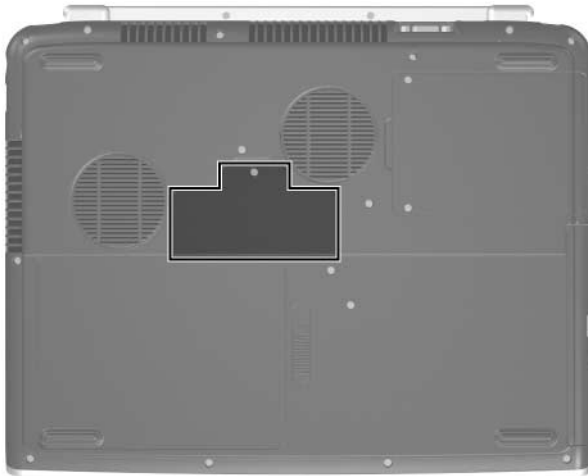

Component	Description
Expansion memory module compartment	Contains one memory module slot. As shipped, the slot may be vacant or may contain a replaceable memory module.*
*Your notebook contains 2 memory module slots. For more memory information refer to Chapter 8, "Memory Modules."	

Wireless Antennae



Components	Description
Antennae (2)*	Send and receive wireless device signals.
	<p>⚠ Exposure to Radio Frequency Radiation. The radiated output power of this device is below the FCC radio frequency exposure limits. Nevertheless, the device should be used in such a manner that the potential for human contact during normal operation is minimized. To avoid the possibility of exceeding the FCC radio frequency exposure limits, human proximity to the antennae should be not less than 20 cm (8 inches) during normal operation, including when the notebook display is closed.</p>
	<p>*The antennae are not visible from the outside of the notebook. For optimal transmission, keep the areas immediately around the antennae free from obstructions.</p>

Additional Hardware Components

The components included with your notebook vary by region, country, notebook model, and the optional hardware you purchased. The following sections identify the standard external components included with most notebook models.

Power and Modem Hardware



Component	Description
① AC adapter*	Converts AC power to DC power.
② Power cord*	Connects an AC adapter to an AC outlet.
③ Battery pack*	Powers the notebook when the notebook is not connected to external power.
④ Modem cable*	Connects the modem to an RJ-11 telephone jack or to a country-specific modem adapter.
⑤ Country-specific modem adapter (included by region as required)*	Adapts the modem cable to a non-RJ-11 telephone jack.

*All components described in this table vary in appearance by region, country, and/or notebook model.

Optical Discs

Software on optical discs, such as CDs or DVDs, is included with all notebook models.

- The discs packaged in the “Required for Setup” bag provide software that is not preinstalled on your notebook. Depending on how you want to use your notebook, you may want to install some or all of these applications. You can install this software at any time.
- The discs packaged in the “Save for Later” bag include recovery discs for software that is preinstalled or preloaded on your notebook. The recovery discs are provided in case you ever need to repair or reinstall preinstalled or preloaded software.
 - Operating system recovery and driver recovery software is included with all notebook models.
 - Application recovery software is provided with select models.

If an operating system update disc is included with your notebook, it is strongly recommended that you install the updates immediately. For instructions and more information about software updates, refer to [“Critical Security Updates for Windows XP”](#) in Chapter 12, “Security.”

For information about installing applications, refer to [“Installing Applications from a Disc”](#) in Chapter 4, “Multimedia.”

For information about using recovery software, refer to [“System Recovery”](#) in Chapter 14, “Software Updates and Recovery.”

Labels

The labels affixed to your notebook provide information you may need when you troubleshoot system problems or travel internationally with the notebook.

- **Service Tag**—Provides the product name, product number (P/N), and serial number (S/N) of your notebook. You may need the product number and the serial number when you contact Customer Care. The Service Tag label is affixed to the bottom of the notebook. To display the information on the Service Tag on your screen, select **Start > Help and Support > My HP Computer**.
- **Microsoft Certificate of Authenticity**—Contains the Microsoft® Windows® Product Key. You may need the Product Key to update or troubleshoot the operating system. This certificate is affixed to the bottom of the notebook.
- **Regulatory label**—Provides regulatory information about the notebook. The Regulatory label is affixed inside the battery bay.
- **Modem Approval label**—Provides regulatory information about the modem and lists the agency approval markings required by some of the countries in which the modem has been approved for use. You may need this information when traveling internationally. The Modem Approval label is affixed inside the battery bay.
- **Wireless certification labels**—Select notebook models include an optional 802.11 wireless device, an optional Bluetooth® device, or both. If your notebook model includes one or more wireless devices, a certificate providing regulatory information about each device and the approval markings of some of the countries in which the device has been approved for use is included with your notebook. You may need this information when traveling internationally. Wireless certification labels are affixed inside the battery bay.

Power Control and Light Locations

The following illustration is provided as a quick reference to the locations of the power controls and lights on the notebook.

The function of each of these items is summarized in [Chapter 1, “Component ID.”](#) Instructions for using these items are provided in this chapter.

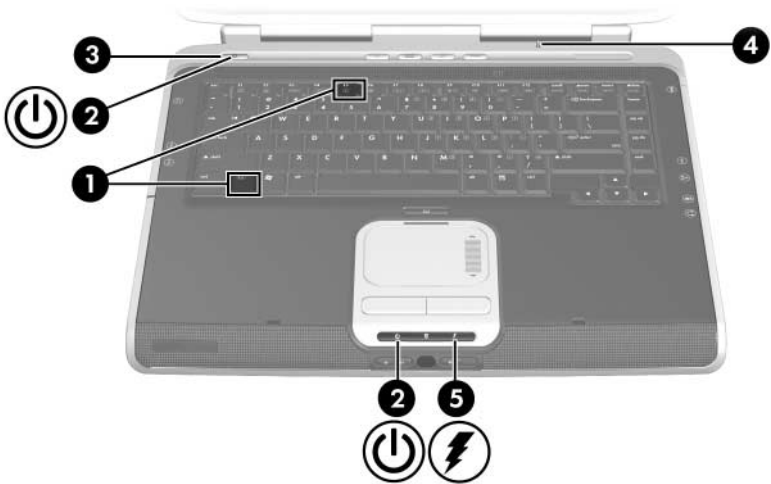

- ❶ **fn+f5** hotkey
- ❷ Power/standby lights (2)
- ❸ Power button
- ❹ Display switch
- ❺ Battery light



The notebook has 2 power/standby lights. The power/standby light on the top of the notebook is visible only when the notebook is open. The power/standby light on the front of the notebook is visible when the notebook is closed.

Power Sources

Selecting a Power Source

The notebook can run on battery power from an inserted battery pack or on external power supplied through the AC adapter or an optional docking device.

You can use power from any of these sources while working in most software applications. It is recommended that you run the notebook on external power whenever you

- Install or modify system software.
- Write to an optical disc.

An inserted battery pack can charge only while the notebook is connected to external power.



WARNING: To reduce the risk of electric shock or damage to your equipment:

- Plug the power cord into an AC outlet that is easily accessible at all times.
 - Disconnect power from the notebook by unplugging the power cord from the AC outlet (not by unplugging the power cord from the notebook).
 - If provided with a 3-pin attachment plug on your power cord, plug the cord into a grounded (earthed) 3-pin outlet. Do not disable the power cord grounding pin; for example, by attaching a 2-pin adapter. The grounding pin is an important safety feature.
-

Using External or Battery Power

The notebook runs on external power whenever external power is available to the notebook. This conserves the charge in an inserted battery pack.

Because the notebook switches between battery power and external power according to the availability of external power:

- If the notebook is running on battery power and you connect the notebook to external power, the notebook switches to external power.
- If the notebook is running on external power (and contains a charged battery pack) and you disconnect the notebook from external power, the notebook switches to battery power.

The current power source is identified by the Power Meter icon, which is displayed by default in the notification area, at the far right of the taskbar.

- The Power Meter icon changes shape whenever the power source changes between battery power and external power.
- When you rest the pointer over the Power Meter icon, a text message that identifies the power source is displayed.

If the Power Meter icon is not displayed, refer to [“Displaying the Power Meter Icon,”](#) later in this chapter.

Standby and Hibernation

Standby

Standby reduces power to system components that are not in use. When standby is initiated, your work is saved in random access memory (RAM), the screen is cleared, and the power/standby lights blink. Saving your work before initiating standby is not usually necessary but is a recommended precaution. When you resume from standby, your work is returned instantly to the screen.

By default, the system initiates standby after 10 minutes of notebook inactivity when the notebook is running on battery power and after 25 minutes of inactivity when the notebook is running on external power. For information about changing these settings, refer to [“Setting or Changing a Power Scheme,”](#) later in this chapter.

Hibernation



CAUTION: If the configuration of the notebook system is changed during hibernation, it may not be possible to resume from hibernation. When the notebook is in hibernation:

- Do not add or remove a memory module.
- Do not connect or disconnect an external device.
- Do not insert or remove a CD, DVD, PC Card, ExpressCard, or digital memory card.

Hibernation saves your work to a hibernation file on the hard drive and then shuts down the notebook. When hibernation is complete, the power/standby lights are turned off. Saving your work before initiating hibernation is not usually necessary but is a recommended precaution.

When you restore from hibernation, your work is returned to the screen where you left off. Restoring from hibernation takes a little longer than resuming from standby but is much faster than returning to your place manually after restarting the notebook.

To determine whether the notebook is in hibernation or turned off, press the power button.

- If the notebook is in hibernation, your work is returned to the screen.
- If the notebook is turned off, Windows loads.

When the notebook is running on battery power, hibernation is initiated by default after 30 minutes of notebook inactivity or whenever the notebook reaches a critical low-battery condition. You can change the length of the period of inactivity before hibernation is initiated. For instructions, refer to [“Setting or Changing a Power Scheme,”](#) later in this chapter.

Hibernation is enabled by default but can be disabled. To prevent loss of work during a critical low-battery condition, disable hibernation only during a battery pack calibration.

To verify that hibernation is enabled:

- » Select **Start > Control Panel > Performance and Maintenance > Power Options > Hibernate** tab. If hibernation is enabled, the **Enable hibernation** check box is selected.



All Windows instructions in your user guides describe Microsoft Windows XP procedures based on the default Windows XP category view.

To switch between category view and classic view within Control Panel:

- » Select **Start > Control Panel**. Then select your preference in the Control Panel pane in the left panel of the Control Panel window.

For more information about Windows XP category view and Windows XP classic view:

- » Select **Start > Help and Support > Customizing your computer > Files, folders, and programs > Use Windows classic folders**.
-

Initiating Standby, Hibernation or Shutdown

The following 3 sections provide information about using standby, hibernation, and shutdown in various circumstances.

For information about how to initiate or resume from standby, how to initiate or restore from hibernation, and how to turn your notebook on or off, refer to “[Default Power Settings](#),” later in this chapter. The “Default Power Settings” section also includes emergency procedures that you can use when you are unable to shut down your notebook using standard Windows procedures.

When You Leave Your Work

If you plan to resume shortly—Initiate standby for shorter times and hibernation for longer times or for power conservation.

The amount of time a battery pack can support standby or hibernation or hold a charge varies by notebook configuration and the condition of the battery pack. Standby requires more power than hibernation.

If you plan to resume within 2 weeks—Shut down the notebook. If possible, connect the notebook to external power to keep an inserted battery pack fully charged.

If the notebook will be unused and disconnected from external power for more than 2 weeks—Shut down the notebook. To extend the life of an inserted battery pack, remove the battery pack and store it in a cool, dry location.

When the Power Supply Is Uncertain

If an external power supply is uncertain, initiate hibernation or shut down the notebook. A power supply may become uncertain because of such conditions as an electrical storm or a nearly discharged battery pack.

When Using Drive Media

To prevent the loss of playback or playback quality, do not initiate standby or hibernation while playing a drive medium such as a CD or DVD.

If standby or hibernation is initiated while a drive medium is in use, you may see the warning message “Putting the computer into hibernation or standby might stop the playback. Do you want to continue?” If the message is displayed, select **No**.

Default Power Settings

The following table describes the default standby, hibernation, and shutdown procedures. For information about changing the function of some of the power features on your notebook, refer to “[Power Options](#),” later in this chapter.

The controls and lights discussed in this section are illustrated in “[Power Control and Light Locations](#),” earlier in this chapter.

Turning the Notebook or Display On or Off

Task	Procedure	Results
Turn on the notebook.	<p>Press the power button.</p> <p> Pressing the power button turns on the notebook from standby, hibernation, or shutdown.</p>	<ul style="list-style-type: none"> ■ Power/standby lights are turned on. ■ If the notebook is <ul style="list-style-type: none"> <input type="checkbox"/> Off, operating system is loaded. <input type="checkbox"/> In standby or hibernation, your work is returned to the screen.
Shut down the notebook.	<ul style="list-style-type: none"> ■ In Windows XP Home, select Start > Turn Off Computer > Turn Off.* ■ In Windows XP Professional, select Start > Turn Off Computer > Shut down > OK.*† 	<ul style="list-style-type: none"> ■ Power/standby lights are turned off. ■ Operating system is shut down. ■ Notebook is turned off.
Turn off the display.	Close the notebook.	When the notebook is closed, the display presses the display switch, which then initiates standby. When standby is initiated, the display is cleared.‡

*If the system is unresponsive and you are unable to shut down the notebook with this procedure, refer to [“Using Emergency Shutdown Procedures,”](#) later in this chapter.

†Depending on your network connections, the Turn Off Computer button may be called the Shut Down button.

‡The function of the display switch can be changed. For instructions, refer to [“Accessing the Power Options Window,”](#) later in this chapter.

Initiating or Restoring from Hibernation

Hibernation cannot be initiated unless it is enabled. Hibernation is enabled by default. To verify that hibernation remains enabled:

- » Select **Start > Control Panel > Performance and Maintenance > Power Options > Hibernate** tab. If hibernation is enabled, the **Enable hibernation** check box is selected.

Task	Procedure	Result
Initiate hibernation.	<p>With the notebook on, use either of the following procedures:</p> <ul style="list-style-type: none"> ■ Briefly press the power button. ■ Select Start > Turn Off Computer. Then hold down shift as you select Stand By.* 	<ul style="list-style-type: none"> ■ Power/standby lights are turned off. ■ Screen is cleared.
Allow the system to initiate hibernation.	<p>No action is required. If the notebook is running on battery power and hibernation is enabled, the system initiates hibernation</p> <ul style="list-style-type: none"> ■ After 30 minutes of notebook inactivity. ■ Whenever the battery pack reaches a critical low-battery condition. 	<ul style="list-style-type: none"> ■ Power/standby lights are turned off. ■ Screen is cleared.
Restore from hibernation.	<p>Press the power button.</p> <p> If the system initiated hibernation because of a critical low-battery condition, connect external power or insert a charged battery pack before you press the power button. (The system may not respond if the drained battery pack is the only power source.)</p>	<ul style="list-style-type: none"> ■ Power/standby lights are turned on. ■ Your work is returned to the screen.

*In Windows XP Professional, depending on your network connections, the Turn Off Computer button may be called the Shut Down button.

Initiating or Resuming from Standby

Task	Procedure	Result
Initiate standby.	<p>With the notebook on, use any of the following procedures:</p> <ul style="list-style-type: none"> ■ Press the fn+f5 hotkey. ■ Close the notebook.* ■ In Windows XP Home, select Start > Turn Off Computer > Stand By.[†] 	<ul style="list-style-type: none"> ■ Power/standby lights blink. ■ Screen is cleared.
Allow the system to initiate standby.	<p>No action is required. The system initiates standby</p> <ul style="list-style-type: none"> ■ After 10 minutes of inactivity while running on battery power. ■ After 25 minutes of inactivity while running on external power. 	<ul style="list-style-type: none"> ■ Power/standby lights blink. ■ Screen is cleared.
Resume from standby.	<p>Use any of the following procedures:</p> <ul style="list-style-type: none"> ■ Press any key. ■ Briefly press the power button. ■ Press the fn+f5 hotkey. <p> Depending on your notebook configuration, you may also be able to resume from standby by activating the TouchPad or an optional external mouse.</p>	<ul style="list-style-type: none"> ■ Power/standby lights are turned on. ■ Your work is returned to the screen.

*Closing the notebook presses the display switch. The function of the display switch can be changed. For instructions, refer to [“Accessing the Power Options Window,”](#) later in this chapter.

[†]In Windows XP Professional, depending on your network connections, the Turn Off Computer button may be called the Shut Down button.

Using Emergency Shutdown Procedures

If the notebook does not respond to the standard Windows shutdown procedure for your operating system, try the following emergency shutdown procedures in the sequence provided:

- Press **ctrl+alt+del**. Then
 - In Windows XP Home, select **Shut Down > Turn Off**.
 - In Windows XP Professional, select **Shut down** from the drop-down list, and then select **OK**.
- Press and hold down the power button for at least 4 seconds.
- Unplug the notebook from external power and remove the battery pack. For battery pack removal instructions refer to [“Inserting or Removing a Battery Pack,”](#) later in this chapter.

Power Options

Accessing the Power Options Window

To access the Power Options window:

- Select **Start > Control Panel > Performance and Maintenance > Power Options**.

– or –

- Right-click the **Power Meter** icon in the notification area, at the far right of the taskbar, and then select **Adjust Power Properties**. If the Power Meter icon is not displayed, refer to [“Displaying the Power Meter Icon,”](#) next in this chapter.

Among the preferences you can set in the Power Options window are the functions of the power button and the display switch.

By default, when the notebook is on:

- Briefly pressing the power button initiates hibernation.
- Closing the notebook presses the display switch, which initiates standby.

To change the function of the power button or the display switch:

1. Select **Start > Control Panel > Performance and Maintenance > Power Options > Advanced** tab.
 - To change the function of the power button, select a function from the drop-down list for **When I press the power button on my computer**.
 - To change the function of the display switch, select a function from the drop-down list for **When I close the lid of my portable computer**.
2. Select **OK**.

The Hibernate function is available in the power button and display switch drop-down lists only if hibernation is enabled. If the Hibernate function is not available on these lists:

1. Select **Start > Control Panel > Performance and Maintenance > Power Options > Hibernate** tab.
2. Select the **Enable hibernation** check box.
3. Then select **OK**.

For information about setting power schemes in the Power Options window, refer to [“Setting or Changing a Power Scheme,”](#) later in this chapter.

Displaying the Power Meter Icon

The Power Meter icon is displayed by default in the notification area, at the far right of the taskbar. If the Power Meter icon is not displayed in your taskbar, the default setting may have been changed.

To display the icon:

1. Select **Start > Control Panel > Performance and Maintenance > Power Options > Advanced** tab.
2. Select the check box for **Always show icon on the taskbar**.
3. Select **OK**.

Setting or Changing a Power Scheme

A power scheme controls the amount of power used by the notebook. You can set power schemes that conserve power while the notebook is running on battery power and power schemes that maximize performance while the notebook is running on external power.

Among the settings that you can use in a power scheme are settings that specify the time intervals before the system initiates standby or hibernation.

To select a preset power scheme or to create a custom power scheme:

- » Select **Start > Control Panel > Performance and Maintenance > Power Options > Power Schemes** tab, and then follow the instructions on the screen.



The preset Max Battery power scheme maximizes battery conservation.

Using a Security Password

Among the security passwords that you can use to protect your notebook is a standby password.

When a standby password is set, you are prompted for the standby password each time the notebook is resumed from standby or restored from hibernation.

The standby password is the password for the Windows user account that is active at the time the password is set.

To set a standby password prompt:

1. Select **Start > Control Panel > Performance and Maintenance > Power Options**.
2. Select the **Advanced** tab.
3. Select the check box for **Prompt for password when computer resumes from standby**.
4. Select **OK**.

For information about other passwords and security features, refer to [Chapter 12, “Security.”](#)

Battery Packs

Inserting or Removing a Battery Pack

CAUTION: To prevent loss of work when removing a battery pack that is the only power source, shut down the notebook or initiate hibernation before removing the battery pack. (If you initiate hibernation, do not begin battery pack removal until the power/standby lights are turned off, indicating that hibernation is complete.)

Inserting a Battery Pack

Although battery packs vary by model, the insertion procedure is the same for all supported battery packs.

To insert a battery pack:

1. Turn the notebook upside down.
2. Slide the battery pack into the battery bay **1**.
3. Pivot the battery pack downward until it is seated **2**.

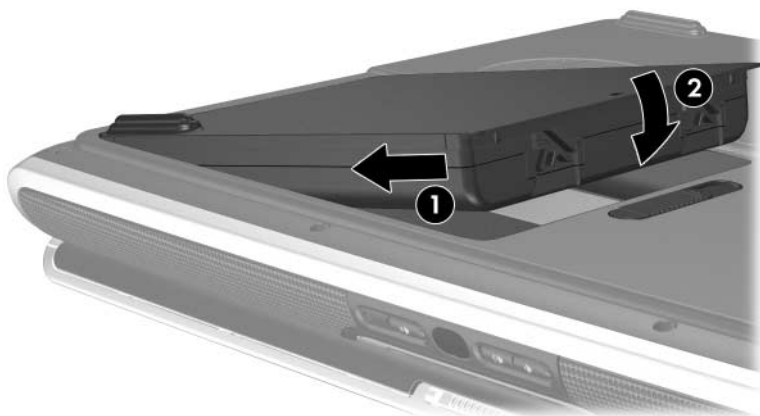

Removing a Battery Pack

Although battery packs vary by model, the removal procedure is the same for all models.

To remove a battery pack:

1. Turn the notebook upside down.
2. Slide and hold the battery pack release latch **1** as you pivot the battery pack out of the battery bay **2**.

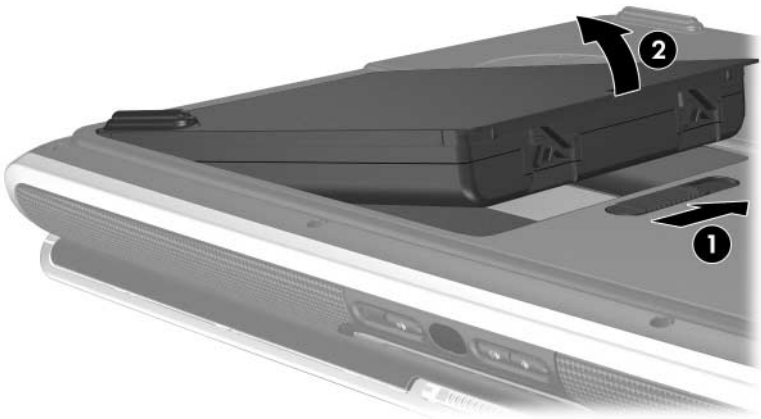

Charging Battery Packs

A battery pack inserted in the notebook charges whenever the notebook is connected to external power through the AC adapter or through an optional docking device.

A battery pack inserted in the notebook charges whether the notebook is off or in use, but the battery pack charges faster while the notebook is off. Charging may be delayed if a battery pack is new, has been unused for 2 weeks or more, or is much warmer or cooler than room temperature.

The battery light displays charging status and, in some circumstances, power availability:

- On: the battery pack is charging.
- Off: the battery pack is fully charged or not installed.
- Blinking: The charge in the battery pack is too low to start the notebook. For example, the battery light blinks if you try to turn on the notebook while the only power source is a nearly discharged battery pack.

To prolong battery life and optimize the accuracy of battery charge displays, follow the instructions in [“Charging a New Battery Pack”](#) and [“Charging an In-Use Battery Pack,”](#) next in this chapter.

Charging a New Battery Pack

To charge a new battery pack:

- Charge the battery pack while the notebook is connected to external power through the AC adapter.
- When you charge the battery pack, charge it fully.

Charging an In-Use Battery Pack

To charge an in-use battery pack:

- Allow the battery pack to discharge to about 10 percent of a full charge through normal use before charging it.
- When you charge the battery pack, charge it fully.

Monitoring the Charge in a Battery Pack

Obtaining Accurate Charge Information

To increase the accuracy of the battery charge information that is displayed by your notebook:

- Allow a battery pack to discharge to about 10 percent of a full charge through normal use before charging it.
- When you charge a battery pack, charge it fully. The charge in even a new battery pack may be reported inaccurately until the battery pack has been fully charged at least once.
- If a battery pack has been unused for one month or more, calibrate the battery pack instead of simply charging it.

For information about battery calibration, refer to [“Calibrating a Battery Pack,”](#) later in this chapter.

Displaying Charge Information on the Screen

To display battery charge information on the screen:

- Select **Start > Control Panel > Performance and Maintenance > Power Options > Power Meter** tab.

– or –

- Right-click the **Power Meter** icon, and then select **Open Power Meter**.

For information about displaying the Power Meter icon, refer to [“Displaying the Power Meter Icon,”](#) earlier in this chapter.

Interpreting Charge Information Displays

Battery charge status is displayed as a percentage, which indicates the amount of charge remaining in the battery pack.

Managing Low-Battery Conditions

This section describes the default system responses to low-battery and critical low-battery conditions. The default battery light responses cannot be changed.

To change other responses:

- » Select **Start > Control Panel > Performance and Maintenance > Power Options > Alarms** tab, and then follow the instructions on the screen.

Identifying Low-Battery Conditions

Low-Battery Condition

When a battery pack that is the only power source for the notebook reaches a *low-battery condition*, a text warning message is displayed.

If you try to start the notebook from a battery pack that is in a low-battery condition, the battery light blinks.

Critical Low-Battery Condition

If a low-battery condition is not resolved and the amount of charge remaining in the battery pack continues to drop, the notebook eventually enters a *critical low-battery condition*. If the notebook is on or in standby when a critical low-battery condition is reached:

- If hibernation is enabled, the system initiates hibernation. Some unsaved work may be lost.
- If hibernation is disabled, the notebook remains briefly in standby, and then shuts down. All unsaved work is lost.

The battery light blinks until the notebook shuts down.

Hibernation is enabled by default. To verify that hibernation remains enabled:

- » Select **Start > Control Panel > Performance and Maintenance > Power Options > Hibernate** tab.

If hibernation is enabled, the **Enable hibernation** check box is selected.

Resolving Low-Battery Conditions



CAUTION: To prevent loss of data when restoring from hibernation: If the notebook has reached a critical low-battery condition and has begun to initiate hibernation, do not restore power until hibernation is complete. When hibernation is complete, the battery light and the power/standby lights are turned off.

When External Power Is Available

To resolve a low-battery condition when external power is available, connect the notebook to the external power source. The external power source could be either of the following items:

- AC adapter
- Optional docking device

When a Charged Battery Pack Is Available

To resolve a low-battery condition when a charged battery pack is available, shut down the notebook or initiate hibernation. Insert a charged battery pack, and then turn on the notebook.

When No Power Source is Available

To resolve a low-battery condition when no power source is available, save your work. Then initiate hibernation or shut down the notebook.

When the Notebook Cannot Restore from Hibernation

If hibernation was initiated at a time when power was so low that the notebook was unable to complete the hibernation process, prompts to delete restoration data may be displayed during the restoration process.

Deleting the restoration data confirms the loss of the data and allows the notebook to be started.

Calibrating a Battery Pack

When to Calibrate

Even if a battery pack is heavily used, calibration should be necessary only once a month. You do not have to calibrate a new battery pack before first use.

Calibration does not usually increase battery run time, but it can increase the accuracy of battery charge displays, especially under the following conditions:

- When the battery pack has been unused for one month or more.
- When the notebook has been running primarily on external power (and rarely on battery power) for more than one month.
- When battery charge displays report large changes in the percentage of power remaining within 2 minutes. For example, if the Power Meter displays 20 percent of a full charge remaining and then less than 2 minutes later displays only 5 percent of a full charge remaining, the rapid drop in charge remaining indicates that the battery pack needs calibration.

For more information about battery charge displays, refer to [“Monitoring the Charge in a Battery Pack,”](#) earlier in this chapter.

How to Calibrate

To calibrate a battery pack, you must fully charge, fully discharge, and then fully recharge the battery pack.

Charging the Battery Pack

Charge the battery pack while the notebook is on. To charge the battery pack:

1. Insert the battery pack into the notebook.
2. Connect the notebook to external power through the AC adapter. (The notebook battery light is on as the battery pack charges.)
3. Leave the notebook connected to external power until the battery pack is fully charged. (The notebook battery light is then turned off.)

Discharging the Battery Pack



CAUTION: To prevent loss of work, save your work before beginning an unattended discharge procedure.

The notebook must remain on throughout the discharge process. The battery pack can discharge whether or not you are using the notebook, but the battery pack will discharge faster if the notebook is in use.

If you use the notebook occasionally during the discharge process described in the following procedure and have set energy-saving timeouts, expect the following performance from your system during the discharge:

- Any unsaved work from your current session will be lost when the battery pack is fully discharged and the notebook is shut down.
- The system will not turn off a connected optional monitor.

- The system will not decrease hard drive speed while the notebook is idle.
- System-initiated standby will not occur.

To fully discharge the battery pack:

1. Disable hibernation. To disable hibernation:
 - a. Select **Start > Control Panel > Performance and Maintenance > Power Options > Hibernate** tab.
 - b. Clear the **Enable hibernation** check box.
2. Select **Start > Control Panel > Performance and Maintenance > Power Options > Power Schemes** tab.
 - a. Record the power scheme displayed in the **Power schemes** field so you can reapply it after the calibration.
 - b. Use the **Power schemes** drop-down list to select the **Always On** power scheme.
 - c. Record all settings in the **Running on batteries** column, so you can reset them after the calibration.
 - d. Use the drop-down lists in the **Running on batteries** column to set each item in the column to **Never**.
 - e. Select **OK**.
3. Disconnect the notebook from the external power source, but do *not* turn off the notebook.
4. Run the notebook on battery power until the battery pack is fully discharged. When the battery pack is fully discharged, the notebook is shut down.

Recharging the Battery Pack

1. Connect the notebook to external power and maintain the connection until the battery pack is fully recharged and the battery light is turned off.

You can use the notebook while the battery pack is recharging, but the battery pack will charge faster if the notebook is turned off.

2. If the notebook is turned off, turn on the notebook when the battery light is turned off, indicating that the battery pack is fully charged.
3. Display the settings on the Power Schemes tab. To access the Power Schemes tab, select **Start > Control Panel > Performance and Maintenance > Power Options > Power Schemes** tab.
 - a. Reapply the power scheme you recorded earlier.
 - b. Reenter the settings you recorded earlier for the items in the **Plugged in** column.
4. Select **OK**.



CAUTION: To prevent an unintended battery drain and a potential loss of work when the notebook reaches a critical low-battery condition, reenabling hibernation after calibrating the battery pack. To reenabling hibernation: Select **Start > Control Panel > Performance and Maintenance > Power Options > Hibernate** tab. Select the **Enable hibernation** check box, and then select **OK**.

Conserving Battery Power

To extend the time that a battery pack can run the notebook from a single charge, use the following battery conservation procedures and settings.

Conserving Power as You Work

To conserve battery power as you work:

- Run the notebook on external power instead of a battery pack whenever possible.
- Prevent devices you are not using from drawing power from the notebook. For example:
 - Turn off wireless and local area network (LAN) connections (select models only) and close modem applications.
 - Disconnect from the notebook any external devices that are not plugged into an external power source.
 - Stop, disable, or remove an inserted
 - ◆ PC Card.
 - ◆ Digital memory card (select models only).
 - ◆ ExpressCard (select models only).
 - Turn off a device connected to the S-Video-out jack.
- Use optional, externally powered speakers instead of the internal speakers whenever possible. When you use the internal speakers, minimize system volume. Volume can be adjusted with the volume buttons.
- Minimize screen brightness. To decrease screen brightness, press the **fn+f7** hotkey. To increase screen brightness, press the **fn+f8** hotkey.
- If you leave your work, initiate standby or hibernation, or shut down the notebook.

Selecting Power Conservation Settings

To set the notebook to use less power:

- Select a short wait for the screen saver and select a screen saver with minimal graphics and motion.

To select a screen saver and a screen saver wait time:

Select **Start > Control Panel > Appearance and Themes > Display > Screen Saver** tab, and then follow the instructions on the screen.

- Select or create a power scheme that minimizes power use. The preset power scheme that maximizes battery conservation is Max Battery.

For information about selecting or creating a power scheme, refer to [“Setting or Changing a Power Scheme,”](#) earlier in this chapter.

Storing a Battery Pack



CAUTION: To prevent damage to a battery pack, do not expose it to high temperatures for extended periods of time.

If the notebook will be unused and disconnected from external power for more than 2 weeks, remove and store the battery pack.

High temperatures, which may be present in parked cars or some workplaces, accelerate the self-discharge rate of a stored battery pack. To prolong the charge of a stored battery pack, place it in a location that is cool and dry.

Calibrate a battery pack that has been stored for one month or more before using it. For instructions, refer to [“Calibrating a Battery Pack,”](#) earlier in this chapter.

Disposing of a Used Battery Pack



WARNING: To reduce the risk of fire or burns, do not disassemble, crush, or puncture a battery pack; short the external contacts on a battery pack; or dispose of a battery pack in fire or water. Do not expose a battery pack to high temperatures above 60°C (140°F). Replace a battery pack only with a battery pack approved for this notebook.



When a battery pack has reached the end of its useful life, do not dispose of the battery pack in general household waste. Follow the local laws and regulations in your area for computer battery pack disposal.

In Europe, dispose of or recycle battery packs by using the public collection system or by returning them to HP, your service partner, or their agents.

TouchPad

Using the TouchPad

The TouchPad, shown in the following illustration, is enabled each time the notebook is turned on.

When the TouchPad is enabled, the TouchPad light **1** is on and the TouchPad provides the functions of an optional external mouse:

- To move the pointer, slide your finger across the TouchPad surface **2** in the direction you want to move the pointer.
- To execute the click functions of the left or right button on an external mouse, press the left or right TouchPad button **3**.
- To scroll vertically, place your finger on the scroll zone **4**, and then slide your finger upward or downward. (To activate the scroll zone, you must first lift your finger from the TouchPad and then place your finger on the scroll zone.)
- To disable or reenable the TouchPad, press the TouchPad button **5**. (If you work exclusively with keystrokes rather than mouse actions, you may want to disable the TouchPad to prevent accidental TouchPad activity.)

Additional TouchPad functions are described in [“Setting Mouse Properties,”](#) next in this chapter.

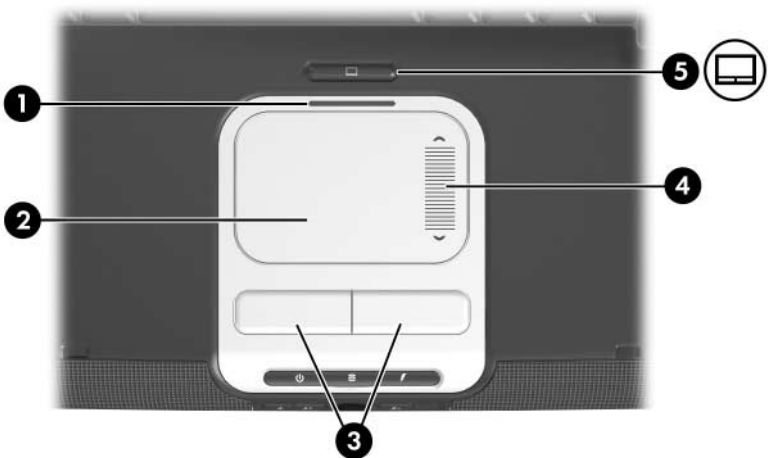

Setting Mouse Properties

TouchPad preferences are set in the **Mouse Properties** window and the **TouchPad Properties** window.

To access the **Mouse Properties** window:

- » Select **Start > Control Panel > Printers and Other Hardware > Mouse**.

To access the **TouchPad Properties** window:

1. Use the TouchPad to select **Start > Control Panel > Printers and Other Hardware > Mouse > Device Settings**.
2. Then select the **Settings** button. (If you follow this path using an optional external mouse, the **TouchPad Properties** window may be unavailable.)

In the **Mouse Properties** window you can

- Adjust basic pointing device settings such as click speed, mouse trails, and pointer speed and shape.
- Configure the right and left TouchPad buttons for right-handed or left-handed use. These buttons are set by default for right-handed use.

In the **TouchPad Properties** window you can access additional TouchPad preferences such as

- **Tapping**, which enables you to tap the TouchPad once to select an item or twice to double-click an item.

To access Tapping settings, select **Tapping**.

- **Edge Motion**, which sets the TouchPad to continue cursor movement when your finger reaches the edge of the TouchPad.

To access Edge Motion settings, select **Pointer Motion**.

- **Long Distance Scrolling**, which sets the scrolling region to continue scrolling when your finger reaches the end of the scrolling region.

To access Long Distance Scrolling, select **Virtual Scrolling**.

Hotkeys

Hotkey Quick Reference

A hotkey is a preset combination of the **fn** key with either the **esc** key or one of the function keys.

The icons on the function keys, **f1** through **f12**, represent their hotkey functions. Hotkey functions are summarized in the following table.

You can display a similar summary of hotkey functions on your screen. For instructions, refer to “[Displaying Hotkey Information](#),” later in this chapter.

Default Function	Hotkey
Opens Help and Support Center.	fn+f1
Opens print window.	fn+f2
Opens default Internet browser.	fn+f3
Switches the image among displays.	fn+f4
Initiates standby.	fn+f5
Initiates QuickLock.	fn+f6
Decreases screen brightness.	fn+f7
Increases screen brightness.	fn+f8
Plays, pauses, or resumes an audio CD or DVD.	fn+f9
Stops an audio CD or DVD.	fn+f10
Plays the previous track or chapter on an audio CD or DVD.	fn+f11
Plays the next track or chapter on an audio CD or DVD.	fn+f12
Displays system information.*	fn+esc

*To clear the system information display, press **esc**.

Using Hotkey Procedures

To use a hotkey command on the notebook keyboard, use either of the following procedures:

- Briefly press **fn**, and then briefly press the second key of the hotkey command.
- Press and hold down **fn**, briefly press the second key of the hotkey command, and then release both keys at the same time.

Hotkey commands can also be used on an optional external keyboard. For instructions refer to [“Using Hotkeys with External Keyboards,”](#) later in this chapter.

Using Hotkey Commands

Opening the Help and Support Center (fn+f1)

The **fn+f1** hotkey opens the Help and Support Center. You can also access the Help and Support Center by selecting **Start > Help and Support**.

In addition to providing information about your operating system, the Help and Support Center provides

- Information about your notebook, such as model and serial number, installed software, hardware components, and specifications.
- Answers to questions about using your notebook.
- Tutorials to help you learn to use notebook and operating system features.

- Updates for your operating system, device drivers, and the software provided on your notebook.
- Checkups for notebook functionality.
- Automated and interactive troubleshooting, repair solutions, and system recovery procedures.
- Links to Customer Care.

Opening the Print Window (fn+f2)

The **fn+f2** hotkey opens the print window of the active Windows application.

Opening Internet Explorer (fn+f3)

The **fn+f3** hotkey opens the default Web browser. The factory default Web browser is Microsoft Internet Explorer.

- Until you have set up your Internet or network services, the **fn+f3** hotkey opens the Windows Internet Connection Wizard. For information about using this wizard and other Internet connection methods, refer to the printed *Getting Started* guide included with your notebook.
- After you have set up your Internet or network services and your Web browser home page, you can use the **fn+f3** hotkey to quickly access your home page and the Internet.

You can also open Internet Explorer by using the Internet Quick Launch button. For instructions, refer to “[Quick Launch Buttons](#),” later in this chapter.

Switching Displays (fn+f4)

The **fn+f4** hotkey switches the image among display devices connected to the system. For example, if an optional monitor is connected to the notebook through the external monitor port, each time you press the **fn+f4** hotkey the image will switch among the notebook display, the monitor display, and a simultaneous display on both the notebook and the monitor.

Most monitors receive video information from the notebook using the external VGA video standard. The **fn+f4** hotkey can also toggle images among other devices receiving video information from the notebook.

The following video transmission types, with examples of devices that use them, are supported by the **fn+f4** hotkey:

- LCD (notebook display)
- External VGA (most monitors)
- S-Video (televisions, camcorders, VCRs, and video capture boards with S-Video-in jacks)
- Composite video (televisions, camcorders, VCRs, and video capture boards with composite video-in jacks)



Composite video devices can be connected to the system only by using an optional expansion product.

Initiating Standby (fn+f5)

The **fn+f5** hotkey initiates standby.

When standby is initiated, your work is saved in random access memory (RAM), the screen clears, and power is conserved. While the notebook is in standby, the power/standby lights blink.

- To initiate standby, the notebook must be on. If the notebook is in hibernation, you must restore from hibernation before you can initiate standby.
- To resume from standby or restore from hibernation, briefly press the power button. You can also resume from standby by pressing any key or by performing an action with the TouchPad or an optional pointing device, such as an external mouse.

For more information about using standby and hibernation, refer to [Chapter 2, “Power.”](#)

Initiating QuickLock (fn+f6)

The **fn+f6** hotkey initiates the QuickLock security feature.

QuickLock protects a Windows account by displaying a log on window. To access the protected account from the log on window, the Windows password for the protected account must be entered.

Before you can use QuickLock, you must set a Windows user password or a Windows administrator password for the account you want to protect. (A Windows user password protects a Windows user account; a Windows administrator password protects a Windows administrator account.)

To set password for a Windows account:

1. Select **Start > Control Panel > User Accounts > User Accounts**.
2. Select the account.

3. Select **Create a password**, and then follow the instructions on the screen.



If the account is already protected by a Windows password, the Create a password link is not displayed. You can lock and unlock the account as described next in this section by the existing password.

After you have set a Windows password for a Windows account, you can protect the account with a log on window whenever the account is active.

- To lock the account, press **fn+f6**.
- To unlock the account from the log on window:
 - a. Select the account (if more than one account is displayed)
 - b. Type the account password in the password text field.
 - c. Press **enter**.

When a Windows password is set for a Windows account, you must enter the password to access the account each time the notebook is turned on or restarted.

To access procedures for changing or deleting Windows passwords and for using password hints:

- » Select **Start > Control Panel > User Accounts > User Accounts**.

For information about combining Windows passwords with HP passwords, refer to [“HP and Windows Passwords”](#) in [Chapter 12, “Security.”](#)

Decreasing Screen Brightness (fn+f7)

The **fn+f7** hotkey decreases the brightness of the notebook screen. The longer you hold down the **fn+f7** hotkey, the more the screen dims.

Decreasing screen brightness conserves power.

Increasing Screen Brightness (fn+f8)

The **fn+f8** hotkey increases the brightness of the notebook screen. The longer you hold down the **fn+f8** hotkey, the more the screen brightens.

Using the Media Activity Hotkeys (fn+f9 through fn+f12)

The following 4 media activity hotkeys can control the play of an audio CD or a DVD. To control the play of a video CD, use the media activity controls in your video CD player application.

Playing, Pausing, or Resuming an Audio CD or a DVD (fn+f9)

- If the audio CD or the DVD is not playing, press the **fn+f9** hotkey to begin or resume the play.
- If the audio CD or the DVD is playing, press the **fn+f9** hotkey to pause the play.

Stopping an Audio CD or a DVD (fn+f10)

The **fn+f10** hotkey stops the play of an audio CD or a DVD.

You must stop a CD or DVD that is playing before you can remove it from the optical drive. For more information about inserting or removing a CD or DVD, refer to [“Optical Drive”](#) in [Chapter 5, “Drives.”](#)

Playing the Previous Track or Chapter of an Audio CD or a DVD (fn+f11)

The **fn+f11** hotkey plays the previous track of an audio CD or the previous chapter of a DVD that is playing.

Playing the Next Track or Chapter of an Audio CD or a DVD (fn+f12)

The **fn+f12** hotkey plays the next track of an audio CD or the next chapter of a DVD that is playing.

Displaying System Information (fn+esc)

The **fn+esc** hotkey displays system information such as product name, total memory, processor name, keyboard revision, and system BIOS.

In the **fn+esc** display, the version of the system BIOS (basic input-output system) is displayed as the BIOS date. On some notebook models, the BIOS date is displayed in decimal format. The BIOS date is sometimes called the *system ROM version number*. For information about updating the system ROM, refer to [“Downloading System ROM”](#) in [Chapter 14, “Software Updates and Recovery.”](#)

To clear the **fn+esc** display:

- » Press **esc**.

Using Hotkeys with External Keyboards

To use a hotkey command on an external keyboard, press the **scroll lock** key twice, then the second key of the hotkey combination.

For example, to use the **fn+f5** command on an external keyboard, press **scroll lock+scroll lock+f5**.

Quick Launch Buttons

Three of the buttons above your keyboard are Quick Launch buttons.

At default settings, Quick Launch buttons enable you to access media applications or the Internet with a single keystroke.

Identifying Quick Launch Buttons

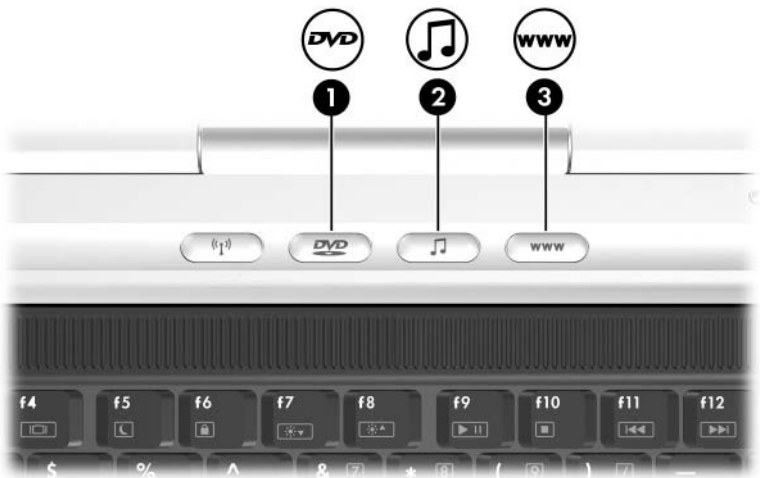

Button Name	Default Function
① DVD button*	Opens the default DVD application.
② Music button*	Opens the default music application.
③ Internet [†]	Opens the default Web browser. The factory default Web browser is Internet Explorer.

*This button is programmable. For instructions, refer to “[Setting DVD and Music Button Preferences](#),” later in this chapter.

[†]Until you set up your Internet or network services, the Internet button opens the Windows Internet Connection Wizard. For information about using this wizard and the other Internet connection options available on your notebook, refer to the *Getting Started* guide included with your notebook.

Quick Launch Buttons Software

You can use the Quick Launch Buttons control panel to

- Set preferences for the display of the Quick Launch Buttons icon.
- Change the default media applications launched by your DVD and music buttons.
- Display hotkeys information.
- Change the size and arrangement of icons and text on your Windows desktop.

The following sections provide instructions for setting preferences within the control panel. For additional on-screen information about any item on the control panel, select the Help button in the upper-right corner of the window. The Help button is identified with a question mark icon.

Displaying the Quick Launch Buttons Icon

To show or hide the Quick Launch Buttons icon on your taskbar or your Windows desktop:

1. Open the Quick Launch Buttons control panel:
 - ❑ Select **Start > Control Panel > Printers and Other Hardware > Quick Launch Buttons**.
 - or –
 - ❑ Select the **Quick Launch Buttons** icon on your taskbar or Windows desktop.

2. Select the **Advanced** tab. On the Advanced tab you can
 - ❑ Display or hide the **Quick Launch Buttons** icon on your taskbar.
 - ◆ To display the icon, select the **Show icon on the taskbar** check box.
 - ◆ To hide the icon, clear the **Show icon on the taskbar** check box.
 - ❑ Display or hide the Quick Launch Buttons icon on your Windows desktop.
 - ◆ To display the icon, select the **Show icon on the desktop** check box.
 - ◆ To hide the icon, clear the **Show icon on the desktop** check box.
3. To save your preferences and close the display, select **OK**.

Setting DVD and Music Button Preferences

At default settings, the DVD button and the music button open factory-assigned media applications. The default assignments vary among notebook models according to which media applications are installed.

You can set these buttons to open different media applications, to access Internet or network destinations, or to access any application, folder, or data file in your system.

Assignments for the DVD button, music button, and the additional media buttons available on an optional remote control are set in the Quick Launch Buttons control panel.

The button settings you select on the Quick Launch Buttons control panel are also applied to buttons on an optional remote control. For example, the remote control also has a DVD button and a music button. If you change the assignment of the music button in the Quick Launch Buttons control panel, the new assignment is applied to both the music button on your notebook and to the music button on the remote control.

1. To open the Quick Launch Buttons control panel, select **Start > Control Panel > Printers and Other Hardware > Quick Launch Buttons**.
2. Select the **Media** tab. Then
 - ❑ To change a button assignment to an application on a drop-down list, press the down arrow beside the displayed application, and then select **OK**.
 - ❑ To remove an item from a drop-down list, use the down arrow to display the item, select **Remove**, and then select **OK**. (Default applications on a drop-down list cannot be removed.)
 - ❑ To add an item to a drop-down list, so that you can assign it to the music button, the DVD button, or a button on an optional remote control, select the displayed item, and then press the **Add** button. Type a name for the new item in the **Name** field. Then
 - ◆ Type or copy a name or URL into the **Assignment** field, and then press **OK**.
 - or –
 - ◆ Press the **Browse** button, select the item, and then press **OK**.

Displaying Hotkey Information

A hotkey is a preset combination of the **fn** key and another key, such as a function key (**f1** through **f12**) or the **esc** key.

To display information about the hotkey functions available on your notebook:

1. Open the Quick Launch Buttons control panel:
 - ❑ Select **Start > Control Panel > Printers and Other Hardware > Quick Launch Buttons**.
 - or –
 - ❑ Select the **Quick Launch Buttons** icon on your taskbar or Windows desktop.
2. Select the **Function Keys** tab.
3. To close the display, select **OK**.

For more information about hotkeys, refer to “[Hotkeys](#),” earlier in this chapter.

Setting Windows Desktop Icon Display Preferences

To change the size of the icons on your desktop and of the text displayed with them:

1. Open the Quick Launch Buttons control panel:
 - ❑ Select **Start > Control Panel > Printers and Other Hardware > Quick Launch Buttons**.
 - or –
 - ❑ Select the **Quick Launch Buttons** icon on your taskbar or Windows desktop.
2. Select the **Zoom** tab.
3. Adjust the slider toward the left and right until your icon display preference is displayed in the illustration above the slider.
4. To save your preference and close the display, select **OK**.

If you select a very large icon display and have set your operating system to Auto Arrange the icons on your Windows desktop, the icons may overlap.

To clear the Auto Arrange setting:

1. Right-click an open area on your Windows desktop.
2. Select **Arrange Icons By**.
3. Select **Auto Arrange** to remove the check mark and disable Auto Arrange.

Keypads

The notebook has an embedded numeric keypad and supports an optional external numeric keypad or an optional external keyboard that includes a numeric keypad.

Depending on your configuration, the embedded keypad may be unavailable while an external keypad is connected to the notebook.

Using the Embedded Numeric Keypad

The embedded numeric keypad consists of 15 keys that can be used like the keys on an external numeric keypad.

When the embedded numeric keypad is turned on, each keypad key performs the functions indicated by the icon in the upper-right corner of the key.



Enabling and Disabling

The embedded numeric keypad is disabled by default.

When the embedded numeric keypad is disabled, press **fn+num lk** ❶ to enable the keypad. The num lock light ❷ is turned on.

When the embedded numeric keypad is enabled, press **fn+num lk** to disable the keypad. The num lock light is turned off.



Switching Key Functions

You can temporarily switch the functions of an embedded numeric keypad key between its standard function and its keypad function.

- To use a key on the keypad as a keypad key while the keypad is turned off, press and hold **fn** while pressing the key.
- To use a key on the keypad as a standard key while the keypad is turned on:
 - Press and hold **fn** to type with the key in lowercase.
 - Press and hold **fn+shift** to type with the key in uppercase.

Releasing **fn** returns a keypad key to its set function. For example, a keypad key returns to its keypad function if the keypad is turned on or to its standard function if the keypad is turned off.

Using an External Numeric Keypad



Depending on your configuration, the embedded keypad may be unavailable while an external keypad is connected to the notebook.

To turn num lock mode on or off on an external numeric keypad, press the **num lk** key on the external keypad, not on the notebook.

- When an external numeric keypad is turned on and is in num lock mode, the num lock light on the notebook is on.
- When an external numeric keypad is turned off or is turned on with num lock mode turned off, the num lock light on the notebook is off.

Most keys on most external numeric keypads function differently when num lock mode is on than when num lock mode is off. For example:

- When num lock mode is on, most keypad keys type numbers.
- When num lock mode is off, most keypad keys function like navigation keys.

Audio Features

Using the Audio-In (Microphone) Jack

The audio-in jack, identified in the following illustration, connects an optional monaural (single sound channel) microphone. The audio-out jack is sometimes called a *microphone* jack.

It is recommended that you use an electret condenser microphone with a 3.5-mm plug. If you connect a dynamic microphone, the recommended sensitivity may not be achieved.



Using the Audio-Out (Headphone) Jack



WARNING: To reduce the risk of personal injury, adjust the volume before putting on headphones.



CAUTION: To prevent possible damage to an external device, do not plug a monaural (single sound channel) plug into the audio-out jack.

The audio-out jack, identified in the following illustration, connects optional headphones or externally powered stereo speakers. The audio-out jack, sometimes called a *headphone* jack, is also used to connect the audio functions of an audio/video device such as a television or VCR.

When you connect a device to the audio-out jack, use only a 3.5-mm plug.

When a device is connected to the audio-out jack, the internal speakers are disabled.



Adjusting the Volume

You can adjust volume with the volume buttons on the notebook or the volume control software available in your operating system and in some multimedia applications. The volume mute button on the notebook overrides all software volume settings.

Using the Volume Buttons

To adjust volume using the notebook volume buttons:

- To decrease volume, press the volume down button ❶.
- To increase volume, press the volume up button ❷.
- To mute or restore volume, press the volume mute button ❸.

When volume is muted, the mute light (on the volume mute button) is turned on. When volume is muted, the mute light ❹ is turned on. When volume is restored, the mute light is turned off.

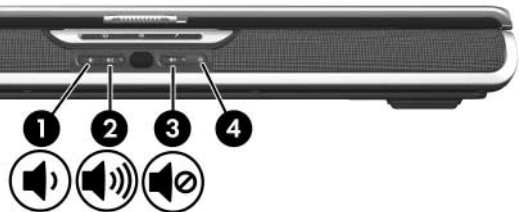

Using the Windows Volume Icon

To place the Windows Volume icon on the taskbar, select **Start > Control Panel > Sounds, Speech, and Audio Devices > Sounds and Audio Devices**, and then select the **Volume** tab. Select the check box for **Place volume icon in the taskbar**, and then select **OK**.

- To adjust volume, select the icon. To increase or decrease volume, drag the slide bar up or down. To mute or restore volume, select or clear the **Mute** check box.
- To access links to additional volume settings, such as balance, right-click the icon.



If you cannot see an icon you have placed on the taskbar, it may be hidden. To display the icon, right-click the taskbar, select **Properties**, clear the **Hide inactive icons** check box, and then select **OK**.

Video Features

Using the S-Video-Jack

The S-Video-out jack supports video signals only.

- This section describes how to connect an S-Video device to the S-Video-out jack on your notebook.
- For information about setting up a configuration that combines audio and video functions, such as playing a DVD movie on your notebook and displaying it on your television, refer to [“Connecting a Monitor, Projector or Television,”](#) later in this chapter.

To transmit video signals through the S-Video-out jack, you need a standard S-Video cable, available from most computer or electronics retailers.

To connect the S-Video cable:

1. Plug either end of the S-Video cable into the notebook S-Video-out jack.

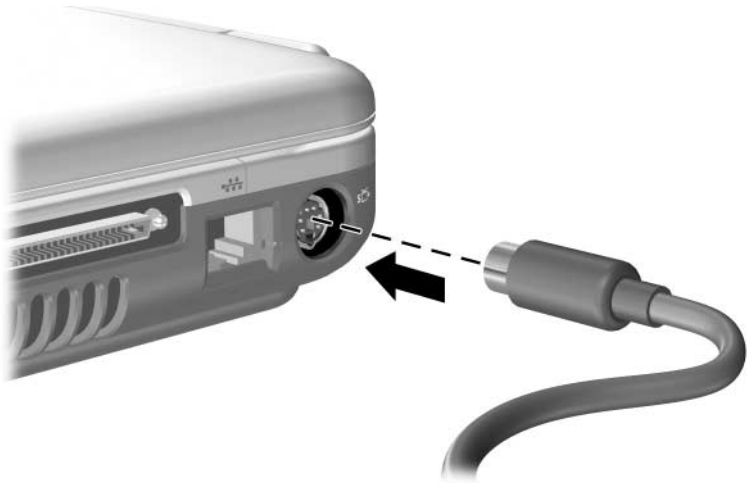

2. Plug the other end of the cable into the *S-Video-in jack* (not the *S-Video-out jack*) on the external device.

Connecting a Monitor, Projector or Television

Connecting a Monitor or Projector

To connect an optional VGA monitor or projector to the notebook:

1. Be sure the monitor or projector is turned off.
2. Connect the VGA cable on the monitor or projector to the external monitor port, which is on the rear of the notebook.



3. Plug the power cord of the monitor or projector into a grounded AC outlet.
4. Turn on the monitor or projector.
 - ❑ If the notebook does not recognize the monitor or projector, restart the notebook.
 - ❑ If a properly connected monitor, projector or other display device does not display an image, try pressing the **fn+f4** hotkey until the image is switched to the new device.

Connecting a Television

To connect a television to the notebook—or to set up most other configurations that combine audio and visual functions—you need an audio cable and an S-Video cable. The cables can be purchased from most computer or electronics retailers.

Connecting the Audio

To connect the audio, you need an audio cable that connects the audio-out (headphone) jack on the notebook to the audio-in connection on the television.

The notebook audio-out jack requires a 3.5 mm plug. If the television requires an RCA connection, you need to use a conversion cable; for example, a 3.5mm stereo to (2) RCA cable. To connect the cable:

1. Plug the 3.5 mm plug end of the audio cable into the audio-out jack on the notebook.
2. Plug the RCA connectors on the other end of the cable into the audio-in connectors on the television.

For more information about the notebook audio-out jack, including an illustration of this connection, refer to [“Using the Audio-Out \(Headphone\) Jack,”](#) earlier in this chapter.

Connecting the Video

To connect the video, you need a standard S-Video cable:

1. Plug either end of the S-Video cable into the notebook S-Video-out jack.
2. Plug the other end of the cable into the *S-Video-in jack* (not the *S-Video-out jack*) on the external device.

For more information about the notebook S-Video-out jack, including an illustration of this connection, refer to [“Using the S-Video-Jack,”](#) earlier in this chapter.

Changing the Video Display

Displaying and Switching the Video Image

To display an image on the notebook display or on an optional external video device display, both the notebook and the video device must be turned on.

To switch the image between the notebook display and the video device display:

- » Repeatedly press the **fn+f4** hotkey. Pressing the **fn+f4** hotkey switches the image among the notebook display, any connected displays, and simultaneous display.

For more information about **fn+f4** and other hotkeys, refer to “Hotkeys” in [Chapter 3, “Keyboard.”](#)

Changing the Color Television Format

Color television formats are modes by which television video signals are sent and received. To send signals between the notebook and a television, both the notebook and the television must be using the same color television format.

Different regions and countries use different formats.

Region-specific formats are set at the factory for most notebooks and are controlled by the location setting of the operating system.

To change the location setting and, with it, the color television format:

1. Select **Start > Control Panel > Date, Time, Language, and Regional Options > Regional and Language Options > Regional Options** tab.
2. In the **Location** pane at the bottom of the **Regional Options** tab, select a region from the drop-down list.
3. Select **OK**.
4. Restart your notebook.

Multimedia Software

Finding Included Multimedia Applications

The multimedia applications included with your notebook are determined by your region and notebook model.

Some of the applications that may be included with your notebook are described in “[Selecting Multimedia Applications](#),” next in this chapter.

Your notebook may include additional multimedia applications. Be sure to explore

- Your desktop icons.
- The applications listed at **Start > All Programs**.
- The preloaded items available at **Start > All Programs > Software Setup**.
- The applications on discs included with your notebook.

For information about installing a preloaded application or an application provided on a disc, refer to “[Installing Multimedia Applications](#),” later in this chapter.

Printed supplementary information about some multimedia applications may be included with some notebook models.

Selecting Multimedia Applications



Some multimedia applications can be used to create CDs or DVDs. CD burning requires a CD-RW drive. DVD burning requires a DVD burner.

Using Default Applications

In most cases, when you insert a disc into the optical drive, the system will open a default application appropriate for the disc. Default applications vary according to which applications are installed. If you prefer to play a disc with an application other than the default application, open your preferred application and then select the disc from within that application.

For information about changing the way the notebook responds when you access the files on an optical disc or other removable storage device, refer to “[Setting AutoPlay Preferences](#),” later in this chapter.

For information about changing the default application assigned to the music button or the DVD button, refer to “[Setting DVD and Music Button Preferences](#)” in Chapter 3, “[Keyboard](#).”

Using Windows Media Player

Microsoft Windows Media Player can be used to play CDs and DVDs and to create audio and data CDs.

Using Windows MovieMaker

Windows MovieMaker can be used to create and edit home movies using basic drag-and-drop procedures.

Using Apple iTunes

Apple iTunes can be used to play audio CDs, copy music to or from CDs, listen to Internet radio stations, share your music library with other computers, and search for and organize music files. Apple iTunes can also be used to create lists of your favorite songs and to create CDs and DVDs.

For AppleiTunes service and support information, visit <http://www.apple.com/support>.

Using Sonic RecordNow!

Sonic RecordNow! can be used to create backups of data files or audio CDs and DVDs, transfer audio files from a CD to a hard drive, and create personalized audio CDs.

Using InterVideo WinDVD Player

InterVideo WinDVD Player can be used to play audio CDs, video CDs, and DVD movies.

Using InterVideo WinDVD Creator

InterVideo WinDVD Creator can be used to create, edit, and burn movies to a DVD or video CD or to present a group of still photographs as a slide show.

InterVideo WinDVD Creator is included only with select notebook models; for example, models that ship with an installed DVD/CD-RW Combo Drive or a DVD±RW and CD-RW Combo Drive.

InterVideo Home Theater

InterVideo Home Theater features vary by notebook model and configuration.

On most notebook models, InterVideo Home Theater can be used to play digital files and media such as MP3 files, video and audio CDs, and DVDs. The application can also be used to create CDs and DVDs.

On some notebook models, InterVideo Home Theater can be used to view television on your notebook when a TV tuner and signal are present.

Installing Multimedia Applications

Installing Preloaded Applications

Some multimedia applications included with your computer are preloaded but not preinstalled. A preloaded item is loaded on your hard drive but cannot be used until it is installed.

To access preloaded items, select **Start > All Programs > Software Setup**. Then:

- To display a list of the software available in a category, select the plus sign (+) beside the category.
- To display a description of a listed item without installing it, select the item. (Descriptions are available for only select items.)
- To install a preloaded item, select the check box for the item, select **Install**, and then follow the instructions on the screen.

Installing Applications from a Disc

Most of the applications on discs included with your notebook can be installed by using the following procedure.

To install multimedia software from a disc:

1. Connect the notebook to reliable external power.
2. Make sure that your notebook is on and in Windows.
3. Close any open applications.
4. Insert the disc into the optical drive. After several seconds, an installation wizard is displayed.

If the installation wizard does not display, your AutoPlay settings may have been modified. To proceed with the installation:

- a. Select **Start > Run**.
 - b. In the **Open** text field, type
x:\setup.exe
where *x* is the drive designation of the drive containing the disc.
 - c. Select **OK**.
5. When the installation wizard is displayed, follow the instructions on the screen.

For more information about AutoPlay settings, refer to [“Setting AutoPlay Preferences,”](#) later in this chapter.

Using Multimedia Applications

Observing the Copyright Warning

It is a criminal offense, under applicable copyright laws, to make unauthorized copies of copyright-protected material, including computer programs, films, broadcasts, and sound recordings. This notebook should not be used for such purposes.

Accessing Help for Multimedia Applications

Most multimedia applications include a Help file that you can access from the menu bar or from an icon that may be identified with a question mark. Most applications also include tutorials.

You can obtain customer support for any multimedia application included with your notebook.



Some CDs and DVDs contain player software which is not included with your notebook, such as PCFriendly. If you insert a disc that contains player software which is not included with your notebook, you are prompted to install the player software. If you prefer to use multimedia applications which are included with your notebook, decline the player installation and close the installation window.

Protecting a CD or DVD Write Process



CAUTION: To prevent loss of work and damage to a disc:

- Before writing to a disc, connect the notebook to a reliable external power source. Do not write to a disc while the notebook is running on battery power.
 - Before writing to a disc, close all open applications (including screen savers and antivirus software) except the disc software you are using.
 - Do not copy directly from a source disc to a destination disc or from a network drive to a destination disc. Instead, copy from a source disc or network drive to your hard drive, and then copy from your hard drive to the destination disc.
 - Do not use the notebook keyboard or move the notebook while the notebook is writing to a disc. The write process is sensitive to vibration.
-

Using Media Activity Hotkeys

A media activity hotkey is a preset combination of the **fn** key ❶ and one of the function keys. You can use media activity hotkeys to control the play of an audio CD or a DVD that is inserted in the optical drive.

To control the play of an inserted video CD, use the media activity controls in your video CD player application.

- To play, pause, or resume an inserted audio CD or a DVD, press **fn** ❶ plus **f9** ❷.
- To stop an inserted audio CD or a DVD that is playing, press **fn** ❶ plus **f10** ❸.
- To play the previous track of an audio CD or the previous chapter of a DVD that is playing, press **fn** ❶ plus **f11** ❹.
- To play the next track of an audio CD or the next chapter of a DVD that is playing, press **fn** ❶ plus **f12** ❺.



For more information about these and other hotkeys, refer to “Hotkeys” in [Chapter 3, “Keyboard.”](#)

Protecting Playback

To prevent the loss of playback or playback quality:

- For optimal playback quality, save your work and close all open applications before playing a CD or a DVD.
- Dock or undock the notebook from an optional docking device *before* or *after* playing a disc, not *while* playing a disc.

Do not initiate standby or hibernation while playing a disc. If standby or hibernation is initiated while a disc is in use, you may see the warning message “Putting the computer into hibernation or standby might stop the playback. Do you want to continue?” If this message is displayed, select **No**.

Setting AutoPlay Preferences

AutoPlay is the operating system feature that determines how the notebook responds when you access files on a removable storage device such as an optical disc.

AutoPlay default settings vary by notebook model and configuration. For example, the first time you insert a disc into an optical drive and close the tray, the disc may begin playing or the AutoPlay pop-up window may be displayed. If the AutoPlay pop-up window is displayed, select your preferences as instructed on the screen.

The default AutoPlay settings can be changed. For example, you can set the notebook to display a slide show of the pictures on a CD containing digital photographs, begin playing the first track of a CD containing music, or display the names of the folders and files on a CD containing data files. You can also set the notebook to prompt you for a preference each time you insert a disc or to do nothing when you insert a disc.

At many AutoPlay settings, there may be a pause of several seconds while AutoPlay opens both the disc and the associated disc player application.

AutoPlay preferences are not available for diskettes, but can be applied to most other removable storage devices. AutoPlay preferences can be set for a digital memory card such as a Secure Digital (SD) Memory Card, Memory Stick, Memory Stick Pro, xD-Picture Card, MultiMediaCard, or SmartMedia (SM) card.

To access AutoPlay settings:

1. Select **Start > My Computer**.
2. Under **Devices with Removable Storage**, right-click an item such as a DVD-ROM drive.
3. Right-click **Properties**.
4. Select the **AutoPlay** tab.

Changing DVD Region Settings



CAUTION: To prevent selecting a permanent region setting that is not your permanent preference, consider that the region setting on a DVD-ROM drive or a combo drive, such as a DVD/CD-RW Combo Drive or a DVD±RW and CD-RW Combo Drive, can be changed only 5 times.

- The region setting you select the fifth time becomes the permanent region setting on the DVD-ROM drive or combo drive.
 - The number of allowable region changes remaining on the drive is displayed in all software that can be used to change a DVD region setting.
-

Most DVDs that contain copyrighted files also contain region codes. The region codes help protect copyrights internationally.

You can play a DVD containing a region code only if the region code on the DVD matches the region setting on your DVD-ROM drive or combo drive. If the region code on a DVD does not match the region setting on your DVD-ROM drive or combo drive, the message, “Playback of content from this region is not permitted,” is displayed when you insert the DVD.

To play the DVD, you must change the region setting on your DVD-ROM drive or combo drive. DVD region settings can be changed in the operating system or in some multimedia applications, as described in the following sections.

Changing DVD Settings in the Operating System

To change DVD region settings in the operating system:

1. Select **Start > Control Panel > Performance and Maintenance > System**.
2. Select the **Hardware** tab.
3. On the Hardware tab, select the **Device Manager** button.
4. Select the plus sign (+) beside **DVD/CD-ROM drives**.
5. Right-click the DVD-ROM drive or combo drive for which you want to change the region setting.
6. Select **Properties**.
7. Select the **DVD Region** tab, and then follow the instructions on the screen.

Changing DVD Settings in a Multimedia Application

If you use InterVideo WinDVD Player software, you may find it more convenient to change DVD region settings within WinDVD Player than to change DVD region settings in the operating system.

To access instructions for changing DVD region settings within InterVideo WinDVD Player:

1. Select **Start > All Programs > InterVideo WinDVD Player**.
2. Then select **Help** on the menu bar of the WinDVD console.

InterVideo WinDVD Player may be included with your notebook. For information about finding the multimedia software included with your notebook, refer to [“Finding Included Multimedia Applications,”](#) earlier in this chapter.

Drive Care



CAUTION: To prevent damage to the notebook or a drive and loss of work:

- Handle a drive carefully. Do not drop it.
- Avoid exposing a hard drive to devices with magnetic fields. Products with magnetic fields include video and audio tape erasure products, monitors, and speakers. Security devices with magnetic fields include airport walk-through devices and security wands. The airport security devices that check carry-on luggage, usually while it is placed on a conveyor belt, use x-rays instead of magnetism and will not damage a hard drive.
- Do not spray a drive with cleaning fluids.
- Avoid exposing a drive to liquids or temperature extremes.
- If you mail a drive, ship it in packaging that protects it from shock, vibration, extreme temperatures, and high humidity. Label the package "FRAGILE."



CAUTION: To reduce the risk of data loss, initiate standby before you move the notebook from one location to another. To initiate standby, press the **fn+f5** hotkey or:

- In Windows XP Home, select **Start > Turn Off Computer > Standby By.**
- In Windows XP Professional, select **Start > Turn Off Computer > Stand by > OK.**

For more information about standby, refer to "[Standby and Hibernation](#)" in [Chapter 2, "Power."](#)

IDE Drive Light

When the IDE (Integrated Drive Electronics) light, identified in the following illustration, is on or blinking, the primary hard drive or an optical drive is being accessed.



Primary Hard Drive

The primary hard drive, sometimes called the *internal* hard drive, is the hard drive inside the hard drive bay.

The hard drive assembly and the hard drive bay should be accessed only by a service partner.

Optical Drive

Inserting an Optical Disc

To protect your CD or DVD during this procedure, handle the disc by the edges, rather than by the flat surfaces.

To insert an optical disc:

1. Be sure the notebook is turned on.
2. To release the media tray, press the release button **1** on the drive bezel.
3. Pull the media tray outward until it is fully extended **2**.
4. Position the disc over the media tray, label-side up.
5. Gently press downward near the center of the disc until the disc snaps into place **3**.
6. Close the media tray **4**.

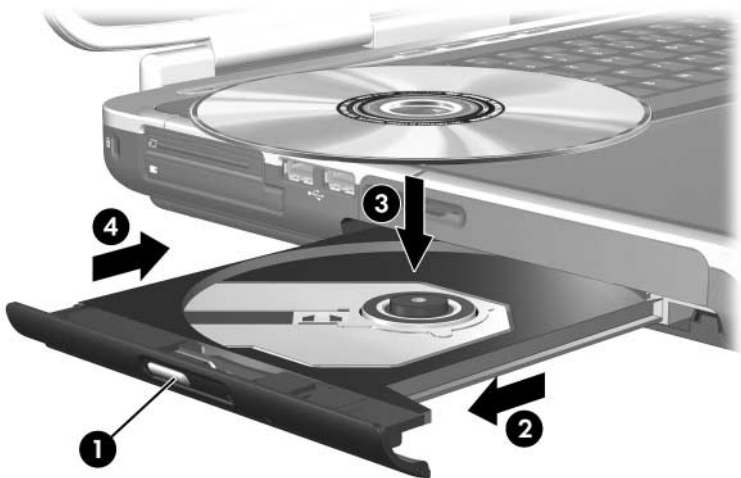

Removing an Optical Disc (With Power)

This procedure can be used only when your notebook is turned on. If your notebook is turned off, refer to “[Removing an Optical Disc \(Without Power\)](#),” next in this chapter.

A CD or DVD that is playing must be stopped before it can be removed. To stop the disc, press the **fn+f10** hotkey. To protect your disc during this procedure, handle the disc by the edges, rather than by the flat surfaces.

To remove an optical disc while the notebook is turned on:

1. To release the media tray, press the release button **1** on the drive bezel.
2. Pull the media tray outward until it is fully extended **2**.
3. To remove the disc from the media tray, gently push downward on the media tray spindle as you gently pull upward on the outer edges of the disc **3**.
4. Close the media tray.
5. To protect the disc, place it in a protective case.

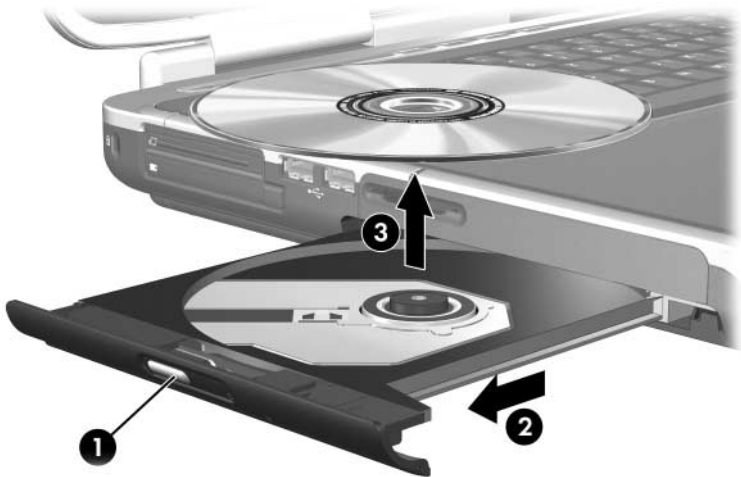

Removing an Optical Disc (Without Power)

When the notebook is turned off or when no power is available to the notebook, the media release button does not work. Use the following procedure to remove a disc without using the media release button.

To protect your CD or DVD during this procedure, handle the disc by the edges, rather than by the flat surfaces.

To remove an optical disc when the notebook is turned off:

1. Insert the end of a small object like a paper clip into the release access ❶ in the front bezel of the drive.
2. To release the media tray, press gently on the paper clip.
3. Pull the tray outward until it is fully extended ❷.
4. To remove the disc from the media tray, gently push downward on the media tray spindle as you gently pull upward on the outer edges of the disc ❸.
5. Close the media tray.
6. To protect the disc, place it in a protective case.

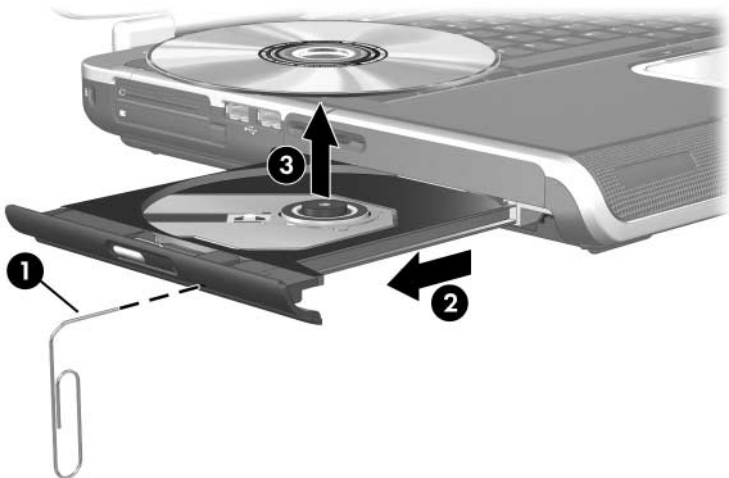

Displaying Optical Disc Contents

Your AutoPlay settings determine how the notebook responds when you insert an optical disc or use software to access an optical disc. For example, AutoPlay can be set to display the contents of discs as soon as they are inserted.

For information about setting AutoPlay preferences, refer to [“Setting AutoPlay Preferences”](#) in [Chapter 4, “Multimedia.”](#)

If AutoPlay is not set to display disc contents at the time a disc is inserted, you can display disc contents manually:

1. Select **Start > Run**.
2. In the **Open** text field, type
x:
where *x* is the drive designation of the drive containing the disc.
3. Select **OK**.



A drive designation is a letter of the alphabet that the notebook uses to identify a drive. To display the drive designation of every drive in the system, select **Start > My Computer**.

Avoiding Standby or Hibernation

To prevent the loss of playback or playback quality, do not initiate standby or hibernation while playing a drive medium such as a CD or DVD.

If standby or hibernation is initiated while a drive medium is in use, you may see the warning message “Putting the computer into hibernation or standby might stop the playback. Do you want to continue?” If the message is displayed, select **No**.

PC Cards and ExpressCards

What Is a PC Card?



CAUTION: To prevent loss of support for some PC Cards, do not install all of the software or any of the enablers provided by a single PC Card manufacturer. If you are instructed by the documentation included with a PC Card to install device drivers:

- Install only the device drivers for your operating system.
- Do not install other software, such as card services, socket services, or enablers, that may also be supplied by the PC Card manufacturer.

A PC Card is a credit card–sized accessory designed to conform to the standard specifications of the Personal Computer Memory Card International Association (PCMCIA). PC Cards can be used to add modem, sound, storage, wireless communication, or digital camera functions to the notebook.

The notebook PC Card slot supports one Type I or Type II 32-bit (CardBus) or 16-bit PC Card.

The notebook PC Card slot can also be used to store an optional remote control. For instructions, refer to the information included with the remote control.

Inserting a PC Card



CAUTION: To prevent damage to the PC Card connectors:

- Use minimal force when inserting a PC Card into a PC Card slot.
- Do not move or transport the notebook while a PC Card is inserted.

As shipped, the PC Card slot contains a protective insert. The insert must be released and then removed before you can insert a PC Card.

1. To remove the PC Card slot insert:
 - a. Press the PC Card eject button **1**. (You may need to press the button once to extend the button, and then press the button again to release the PC Card insert.)
 - b. Pull the insert out of the slot **2**.

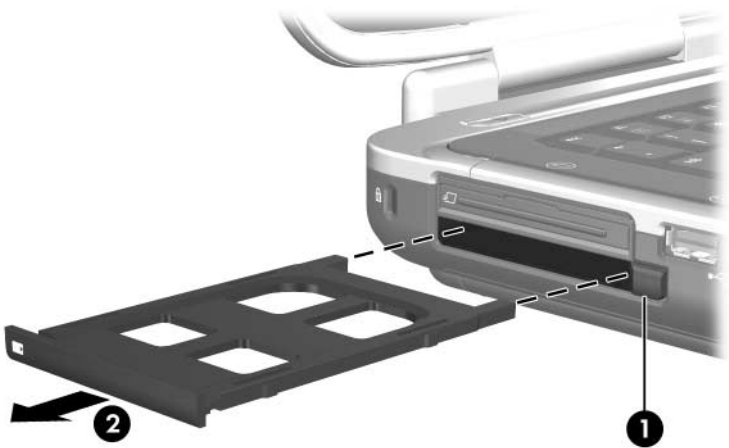

2. To insert a PC Card:

- a. Position the card label-side up with the connectors facing the notebook.
- b. Gently slide the card into the slot until the card is seated.

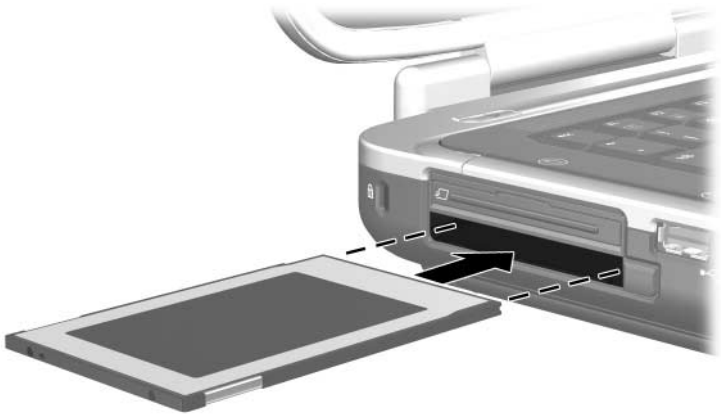

Stopping or Removing a PC Card



CAUTION: To prevent loss of work or an unresponsive system, stop a PC Card before removing it.



Stopping a PC Card, even if it is not in use, conserves power.

To stop or remove a PC Card:

1. Close all applications and complete all activities that are supported by the PC Card. Then
 - ❑ To stop the PC Card, select the **Safely Remove Hardware** icon on the taskbar, and then select **PC Card**. (To display the Safely Remove Hardware icon, right-click the taskbar, select **Properties**, clear the **Hide inactive icons** check box, and then select **OK**.)
 - ❑ To remove the PC Card, stop the PC Card as described in the preceding instruction, and then proceed to step 2.
2. Press the PC card eject button **1**. (You may need to press the button once to extend the button, and then press the button again to release the PC Card.)
3. Gently slide out the PC Card **2**.

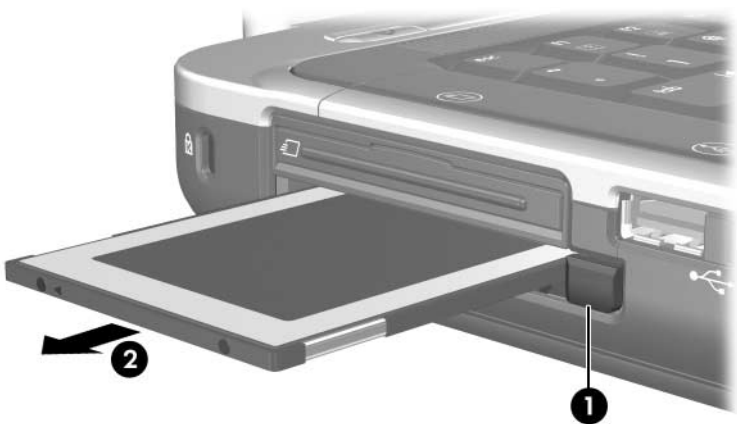

What Is an ExpressCard?

An ExpressCard is a next-generation, high-performance PC Card.

Like standard PC Cards, ExpressCards are designed to conform to the standard specifications of the Personal Computer Memory Card International Association (PCMCIA).

An ExpressCard cannot be used in standard PC Card slot. An ExpressCard slot is available on select models.

Selecting an ExpressCard

ExpressCards use one of 2 interfaces and are available in 2 sizes. The ExpressCard slot supports both interfaces and both sizes. For example, you can use

- An ExpressCard with either a USB interface or a PCI Express interface.
- A full-size ExpressCard, called *ExpressCard/54* ❶, or a smaller ExpressCard, called *ExpressCard/34* ❷.

The ExpressCard procedures described in the following sections are the same for both interfaces and both sizes.

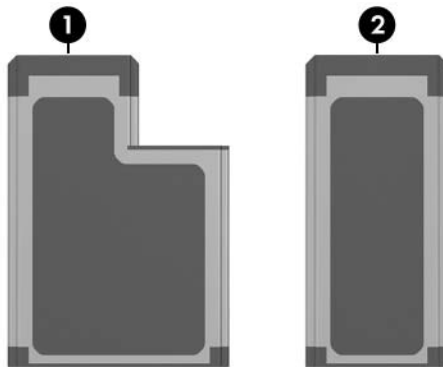

Configuring an ExpressCard



CAUTION: To prevent loss of support for some ExpressCards, do not install all of the software or any of the enablers provided by a single ExpressCard manufacturer. If you are instructed by the documentation included with your ExpressCard to install device drivers:

- Install only the device drivers for your operating system.
 - Do not install other software, such as card services, socket services, or enablers, that may also be supplied by the ExpressCard manufacturer.
-

Inserting an ExpressCard



CAUTION: To prevent damage to the ExpressCard connectors:

- Use minimal force when inserting an ExpressCard into the ExpressCard slot.
 - Do not move or transport the notebook while an ExpressCard is inserted.
-

As shipped, the ExpressCard slot contains a protective insert. The insert must be released and then removed before you can insert an ExpressCard.

1. To release and remove the ExpressCard slot insert:
 - a. Press the insert firmly inward, and then quickly release your pressure **1**.
 - b. Pull the insert out of the slot **2**.

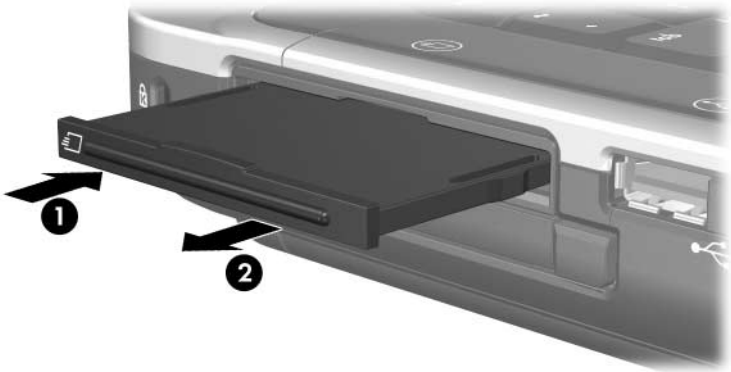

2. To insert an ExpressCard:
 - a. Position the card label-side up with the connectors facing the notebook.
 - b. Gently slide the card into the slot until the card is seated.

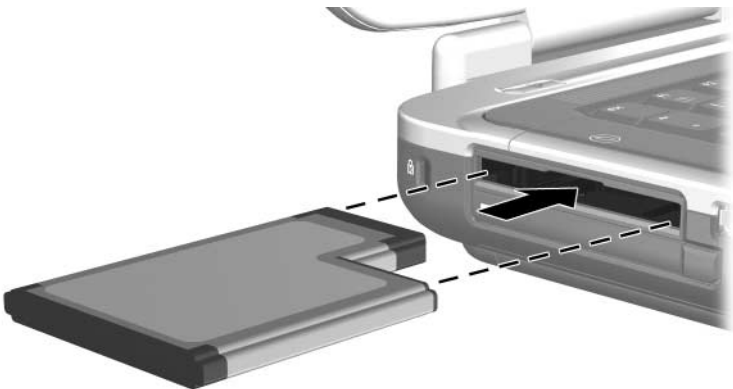

Stopping or Removing an ExpressCard



CAUTION: To prevent loss of work or an unresponsive system, stop the ExpressCard before removing it.



Stopping an ExpressCard, even if it is not in use, conserves power.

To stop or remove an ExpressCard:

1. Close all applications and complete all activities that are supported by the ExpressCard. Then
 - ❑ To stop the ExpressCard, select the **Safely Remove Hardware** icon on the taskbar, and then select the ExpressCard. (To display the Safely Remove Hardware icon, right-click the taskbar, select **Properties**, clear the **Hide inactive icons** check box, and then select **OK**.)
 - ❑ To release and remove the ExpressCard, stop the card as described in the preceding instruction, and then proceed to step 2.
2. To release the ExpressCard, press the ExpressCard firmly inward, and then quickly release your pressure ❶.
3. To remove the card, gently pull it outward from the slot ❷.

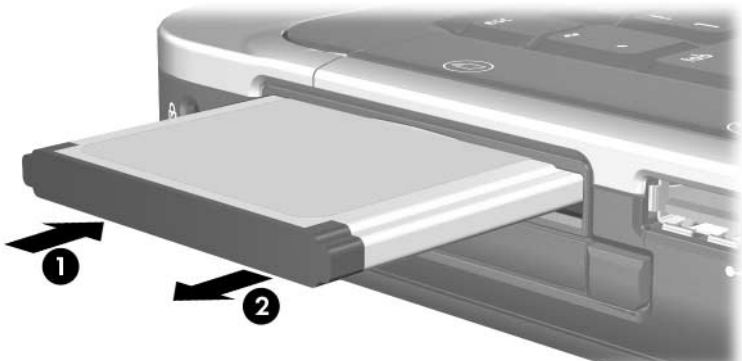

Digital Memory Cards

What Is a Digital Memory Card?

Digital memory cards are often used for digital storage on cameras, camcorders, and other handheld devices.

The Digital Media Slot available on select notebook models supports most digital memory cards. For example, you can use cards of the following types:

- Memory Stick and Memory Stick Pro
- xD-Picture Card
- MultiMediaCard
- SmartMedia (SM) card
- Secure Digital (SD) Memory Card

You can set the notebook to open the files on a digital memory card in ways you specify. For example, you could set a digital memory card to open with a slide show of the photographs it contains. For instructions, refer to [“Setting AutoPlay Preferences”](#) in [Chapter 4, “Multimedia.”](#)

Using the Digital Media Slot Light

The Digital Media Slot light, identified in the following illustration, is available only on notebook models which feature a Digital Media Slot. The light is

- Turned on when an inserted digital memory card is being accessed.
- Turned off when an inserted digital memory card is inactive or when the Digital Media Slot is vacant.



Insertion



CAUTION: To prevent damage to digital memory card connectors:

- Use minimal force when inserting a digital memory card into the Digital Media Slot.
- Do not move or transport the notebook while a digital memory card is inserted in the Digital Media Slot.

To insert a digital memory card:

1. Hold the card label-side up with the connectors facing the notebook.
2. Gently slide the card into the Digital Media Slot until the card is seated. (The card extends slightly beyond the edge of the notebook.)

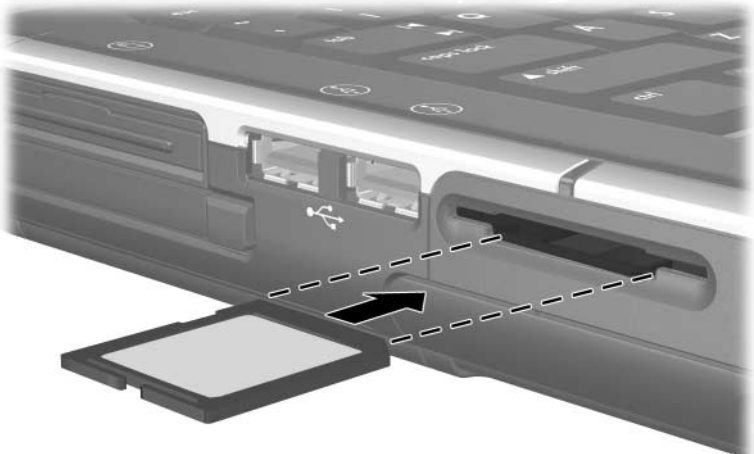

Removal

To stop and remove a digital memory card:

1. Close all applications and complete all activities that are using the card. (To stop a data transfer, select the **Cancel** button in the Windows Copying window.)
2. To stop the card, select the **Safely Remove Hardware** icon on the taskbar, and then select the digital memory card. (To display the Safely Remove Hardware icon, right-click the taskbar, select **Properties**, clear the **Hide inactive icons** check box, and then select **OK**.)
3. To remove the card, slide the card out of the slot.

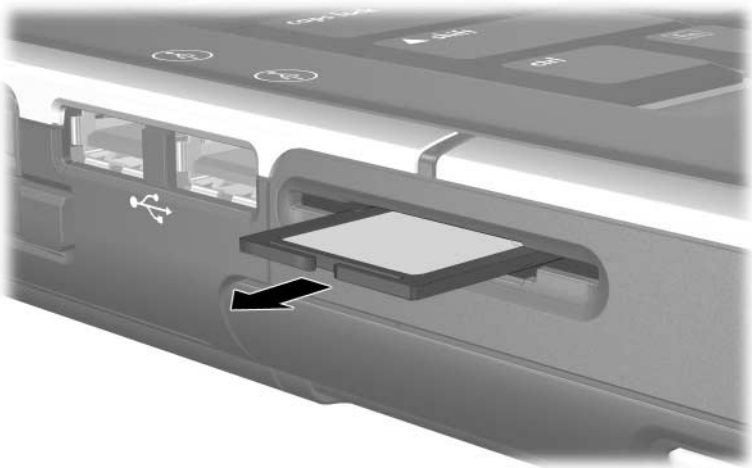

Memory Modules

What Is a Memory Module?

A memory module is a narrow, printed, circuit board that holds memory chips. A memory module is inserted into a memory module slot.

Your notebook has 2 memory module slots, a primary memory module slot and an expansion memory module slot.

Memory modules increase random access memory (RAM). Advanced users can change the speed at which the notebook runs graphics applications, such as 3-D video games, without increasing RAM. For information about this procedure, refer to [“Video Memory Settings,”](#) later in this chapter.

Primary Memory Module Slot

All models of your notebook ship with a memory module installed in the primary memory module slot. The primary memory module slot should be accessed only by a service partner.

Expansion Memory Module Slot

Depending on your notebook model, the expansion memory module slot on your notebook may be vacant or may contain a replaceable memory module. Procedures for installing or replacing a memory module in the expansion memory module slot are provided in [“Removing or Inserting a Memory Module,”](#) later in this chapter.

Selecting a Memory Module

For optimal performance, it is recommended that you install only memory modules approved for use with your notebook model.

- To access information about approved memory modules, select **Start > Help and Support**.
- When you turn on the notebook after inserting a module that is not supported by your notebook, the power/standby lights blink and the notebook beeps 4 times.

Removing or Inserting a Memory Module



WARNING: To prevent exposure to electric shock, access only the expansion memory module compartment during this procedure. The expansion memory module compartment and the battery bay are the only user-accessible internal compartments on the notebook. All other areas that require a tool to access should be opened only by a service partner.



WARNING: To prevent exposure to electric shock and damage to the notebook, shut down the notebook, unplug the power cord, and remove the battery pack before installing a memory module.



CAUTION: To prevent electrostatic discharge from damaging electronic components: before beginning this procedure, discharge yourself of static electricity by touching a grounded metal object. For more information about preventing electrostatic damage, refer to the “Electrostatic Discharge” chapter in the *Regulatory and Safety Information* guide.

1. Save your work and close all open applications.
2. Shut down the notebook.

If you are unsure whether the notebook is off or in hibernation, turn the notebook on and then shut it down through the operating system.

3. Disconnect all external devices connected to the notebook.

4. Disconnect the notebook from external power.
5. Turn the notebook upside down.
6. Remove the battery pack. (For instructions, refer to [“Inserting or Removing a Battery Pack”](#) in [Chapter 2, “Power.”](#))
7. Loosen the expansion memory module compartment screw **1**, and then lift up and remove the expansion memory module compartment cover **2**.

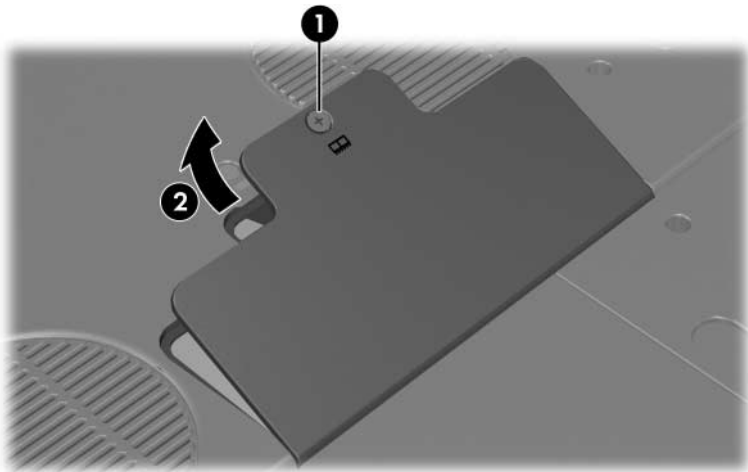

8. Remove or insert the memory module.

To remove a memory module:

- a. Pull away the retention clips on each side of the module ❶. (The module tilts upward.)
- b. Grasp the module by the edges, and then gently pull the module out of the expansion memory module slot ❷.
- c. To protect a memory module after removal, place it in an electrostatic-safe container.

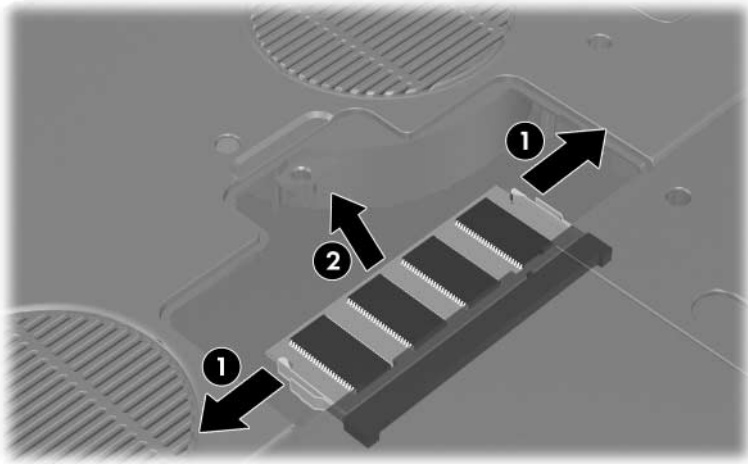

To insert a memory module:

- a. Align the keyed (notched) edge of the module with the keyed (tabbed) area in the expansion memory module slot **1**.
- b. With the module at a 45-degree angle from the surface of the expansion memory module compartment, press the module into the expansion memory module slot until the module is seated **2**.
- c. Push the module downward until the retention clips snap into place **3**.

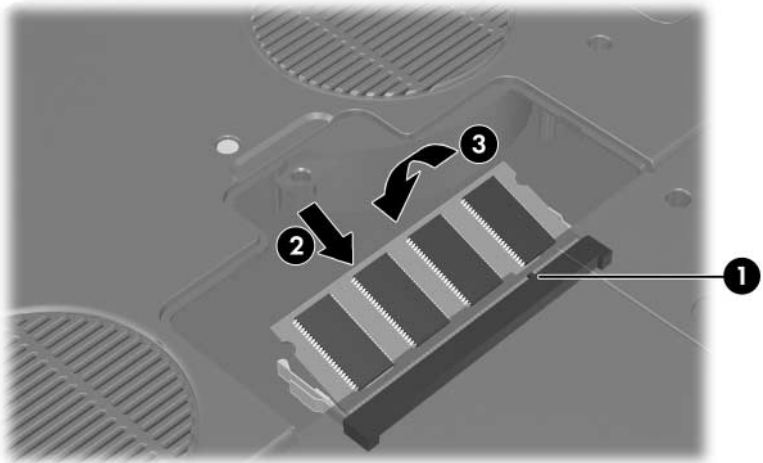

9. To close the expansion memory module compartment:
 - a. Align the tabs on the expansion memory module compartment cover with the cover slots on the notebook ❶.
 - b. Tilt the cover downward until it is seated ❷.
10. To secure the expansion memory module compartment cover, reinsert and then tighten the screw that secures the cover to the notebook ❸.

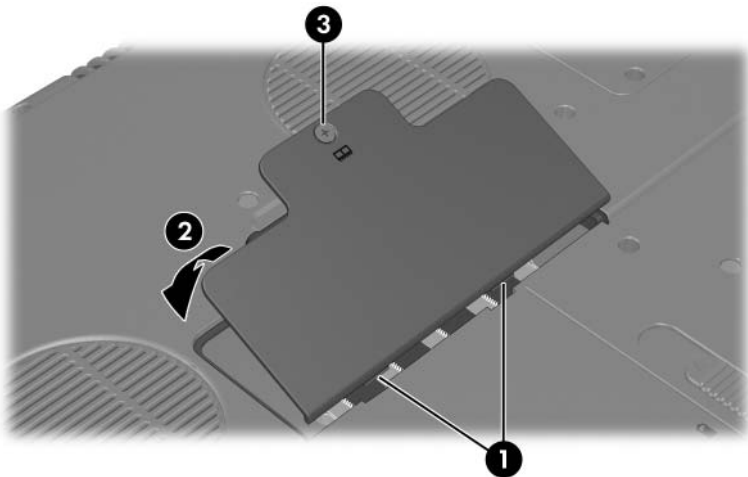

11. Replace the battery pack, reconnect the notebook to external power, and then turn on the notebook.

Hibernation File

When random access memory (RAM) is increased, the operating system increases the hard drive space reserved for the hibernation file.

If you experience problems with hibernation after increasing RAM, verify that your hard drive has enough free space to accommodate a larger hibernation file.

- To display the amount of RAM in the system:

Select **Start > Help and Support Center > My HP Computer**.

- To display both the amount of free space on your hard drive and the amount of space required by the hibernation file:

Select **Start > Control Panel > Performance and Maintenance > Power Options > Hibernate** tab.

Video Memory Settings

Video memory capabilities and settings vary by notebook model.

On select models you can improve the video performance of the notebook while using graphics-intensive applications, such as 3-D games, by changing the default shared video memory setting. This setting affects the amount of memory reserved for graphics functions.

The shared video memory setting can be changed only on select notebook models and should be changed only by advanced users.

To access the memory information and settings available on the Advanced menu in the Setup utility:

1. If you are not sure whether the notebook is off or in hibernation, press the power button. (The notebook turns on or restores from hibernation.)

2. Display the Setup message:
 - ❑ If the notebook is on, restart the notebook through the operating system.
 - ❑ If you are certain that the notebook is off and not in hibernation, turn the notebook on.
3. Press **f10** while the “Press <F10> to enter Setup” message is displayed in the lower-left corner of the screen.
4. Select the **Advanced** menu. (Memory information and settings are displayed.)
5. To change the shared video memory setting, use the navigation and selection information at the bottom of the screen to choose your **Shared video memory** preference.
6. To set your preference and exit the Setup utility, press **f10** and then follow the instructions on the screen.

Your preferences are in effect when the notebook restarts in Windows.

For more information about the Setup utility, including instructions for navigating and selecting items within the utility and instructions for closing the utility without saving any changes from your current Setup utility session, refer to [Chapter 13, “Setup Utility.”](#)

USB and 1394 Devices

What Is USB?

USB (Universal Serial Bus) is a hardware interface that can be used to connect an external device such as a USB keyboard, mouse, drive, printer, scanner, or hub to the notebook or an optional docking device.

A hub is a connecting device that can be either powered or unpowered. USB hubs can be connected to a USB port on the notebook or to other USB hubs. Hubs support varying numbers of USB devices and are used to increase the number of USB devices in the system.



Powered hubs must be connected to external power.

Unpowered hubs must be connected either to a USB port on the notebook or to a port on a powered hub.

A USB device may require support software, which is usually included along with installation instructions, with the device.

The 4 USB ports on the notebook support USB 2.0-compliant, USB 1.1-compliant, and USB 1.0-compliant devices.

USB Device Connection

A USB device can be connected to any of the 4 USB ports on the notebook.

The USB ports are on the rear **1**, left side **2** and **3**, and right side **4** of the notebook.



What Is 1394?

IEEE 1394 is a hardware interface that can be used to connect a high-speed multimedia or data storage device to the notebook. Scanners, digital cameras, and digital camcorders often require a 1394 connection.

A 1394 port is available on select notebook models.

1394 Device Connection

Connect a 1394 device to the notebook 1394 port, shown in the following illustration. The port supports IEEE 1394a devices.

You may have to load device-specific drivers and other software before using some 1394 devices. For information about device-specific software, refer to the device documentation or to the Web site of the device manufacturer or provider.

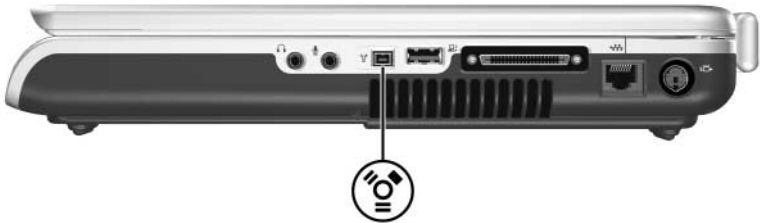

Modem and Networking

Internal Modem

Modem Cable

Your notebook has an RJ-11 (modem) jack and an internal modem. A modem cable with a 6-pin RJ-11 connector at each end is included with all notebook models.

If you purchased your notebook in a country where RJ-11 jacks are not standard, a country-specific modem adapter is also included. The adapter enables you to connect your modem to the type of telephone jack that is standard in your country.



CAUTION: To prevent permanent damage to the modem, do not connect the modem to a digital line. If you accidentally connect the modem cable to a digital line, immediately disconnect the cable.

Your modem cable must be connected to an analog, not a digital, telephone line. Most home telephone lines are analog. Jacks for most PBX systems are digital. Some digital PBX jacks resemble analog jacks, but they are not compatible with the modem.

Some modem cables include noise suppression circuitry, as shown in the following illustration.

Noise suppression circuitry prevents interference from television and radio reception.

When you connect a modem cable with noise suppression circuitry ❷, orient the circuitry end ❶ of the cable toward notebook.

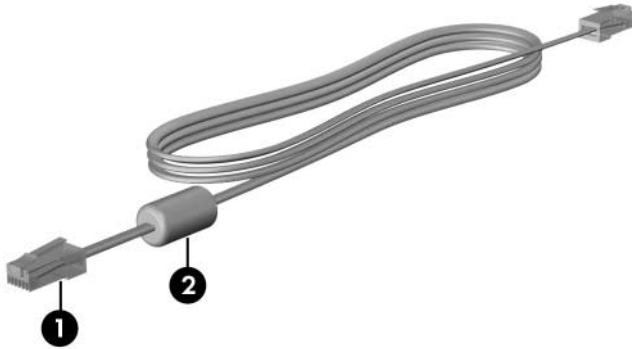

Modem cables vary in appearance by region and country.

Using the Modem Cable



WARNING: To avoid the risk of electric shock, fire, or damage to the equipment, do not plug a modem cable into the notebook RJ-45 (network) jack.

To connect the modem to an analog telephone line that has an RJ-11 jack:

1. Plug the modem cable into the RJ-11 (modem) jack **1** on the notebook.
2. Plug the other end of the modem cable into the telephone wall jack **2**.

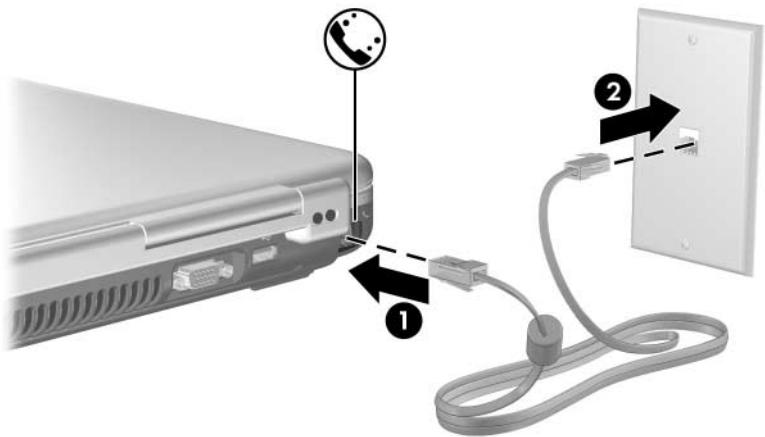

Telephone wall jacks and modem cables vary in appearance by region and country.

Using a Country-Specific Modem Cable Adapter



WARNING: To avoid the risk of electric shock, fire, or damage to the equipment, do not plug a telephone cable into the notebook RJ-45 (network) jack.

To connect the modem to an analog telephone line that does not have an RJ-11 telephone jack:

1. Plug the modem cable into the RJ-11 (modem) jack **1** on the notebook.
2. Plug the modem cable **2** into the country-specific modem adapter.
3. Plug the country-specific modem adapter **3** into the telephone wall jack.

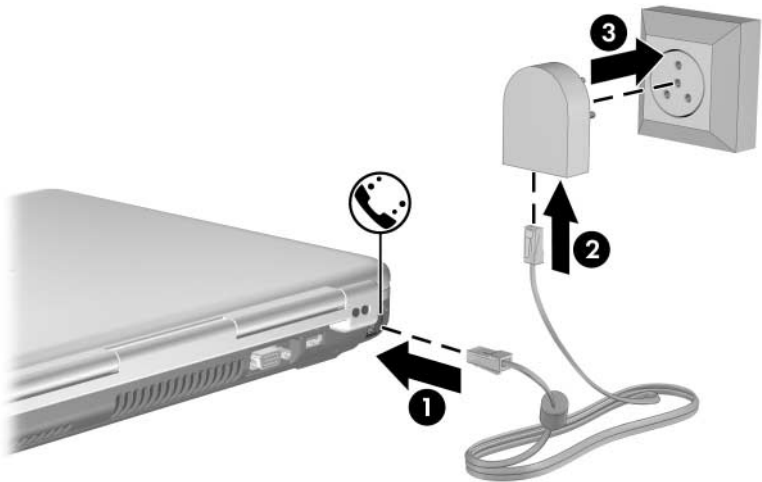

Telephone wall jacks, modem adapters, and modem cables vary in appearance by region and country.

Modem Country Selection

Your modem is set by default to meet only the operating standards of the country in which you purchased your notebook. When you travel internationally, you can change your modem settings to meet the operating standards of other countries.

Viewing the Current Country Selection

To display the current location setting for your modem:

1. Select **Start > Control Panel > Date, Time, Language, and Regional Options**.
2. Select **Regional and Language Options**. (The current location setting for your modem is displayed in the Location pane at the bottom of the Regional Options tab.)

Adding New Locations When Traveling



CAUTION: To prevent possible modem malfunction and violation of telecommunications regulations and laws, set the modem to a location setting for the country in which you are using the modem.

As you travel to different countries, it is recommended that you set the internal modem to a location setting that meets the operating standards of the country in which you are using the modem.

By default, the only location setting available to your modem is a location setting for the country in which you purchased the notebook. As you add new location settings, they are saved by your notebook so that you can switch among the settings at any time. You can add multiple location settings for any country.



CAUTION: To prevent the loss of your default modem location setting, which typically includes the country setting for your home country, do not delete your default modem location setting. The following procedure explains how to add new location settings without deleting any existing location settings.

To add a location setting for your modem:

1. Select **Start > Control Panel > Printers and Other Hardware > Phone and Modem Options**.
2. Select the **Dialing Rules** tab.
3. Select **New**. (The New Location dialog box is displayed.)
4. Type a name for the new location setting in the **Location name** text field.
5. Select a country or region from the **Country/region** drop-down list. (If you select a country or region that is not supported by the modem, the **Country/region** selection for *USA* or *UK* is displayed by default.)
6. To save your new location setting, select **OK**. (The Dialing Rules window is displayed.) Then:
 - To set your new location setting as the current location setting, select **OK**.
 - To select another location setting as the current location setting, select your preference from the settings in the **Location** list, and then select **OK**.



You can use the preceding procedure to add location settings for places within your own country as well as places in other countries. For example, you could add a setting named “Work” that includes dialing rules for accessing an outside line.

Solving Travel Connection Problems

If you experience connection problems while using the modem outside the country in which you purchased the notebook, the following suggestions may be helpful:

■ Check the telephone line type.

The modem requires an analog, not a digital, telephone line. A line described as a PBX line is usually a digital line. A telephone line described as a data line, fax machine line, modem line, or standard telephone line is probably an analog line.

■ Check for pulse or tone dialing.

An analog telephone line supports one of 2 dialing modes, pulse dialing or tone dialing. Modem location settings include dialing mode options. The dialing mode option set in your current modem location setting must be the dialing mode supported by the telephone line.

To determine the dialing mode supported by a telephone line, dial a few digits on the telephone, and then listen for clicks (pulses) or tones. Clicks indicate that the telephone line supports pulse dialing. Tones indicate that the telephone line supports tone dialing.

To change the dialing mode option in your current modem location setting:

1. Select **Start > Control Panel > Printers and Other Hardware > Phone and Modem Options**.
2. Select the **Dialing Rules** tab.
3. Select your modem location setting.
4. Select **Edit**.
5. Select either **Tone** or **Pulse**.
6. Select **OK > OK**.

■ **Check the telephone number you are dialing and the response of the remote modem.**

Dial the telephone number on the telephone, make sure there is a response from the remote modem, and then hang up.

■ **Set the modem to ignore dial tones.**

If the modem receives a dial tone it does not recognize, it will not dial and will display a No Dial Tone error message.

To set the modem to ignore all dial tones before dialing:

1. Select **Start > Control Panel > Printers and Other Hardware > Phone and Modem Options.**
2. Select the **Modems** tab.
3. Select your modem.
4. Select **Properties.**
5. Select the **Modem** tab.
6. Clear the check box for **Wait for Dial Tone Before Dialing.**
7. Select **OK > OK.**

If you continue to receive the No Dial Tone error message after clearing the Wait for Dial Tone Before Dialing check box:

1. Select **Start > Control Panel > Printers and Other Hardware > Phone and Modem Options.**
2. Select the **Dialing Rules** tab.
3. Select your current modem location setting.
4. Select **Edit.**
5. Select your current location from the **Country/region** drop-down list. (If you select a country or region that is not supported by the modem, the **Country/region** selection for *USA* or *UK* is displayed by default.)
6. Select **Apply**, and then select **OK.**

7. In the **Phone and Modem Options** dialog box, select the **Modems** tab.
8. Select your modem, and then select **Properties**.
9. Clear the check box for **Wait for dial tone before dialing**.
10. Select **OK > OK**.

Preinstalled Communication Software

To access preinstalled modem software for terminal emulation and data transfer:

1. Select **Start > All Programs > Accessories > Communications**.
2. Select a fax or terminal emulation program or a connection wizard.

For information about establishing an Internet connection for your modem, refer to the “Connect to the Internet” section in the printed *Getting Started* guide included with your notebook.

For more modem information, including instructions for using AT commands and dial modifiers, refer to the supplementary guides included with your notebook. These guides, which are provided only in English, include *Modem Command Guidelines (Advanced Users Only)* and a guide to the AT commands supported by your modem.

Network

Network Cable

Your notebook has an 8-pin RJ-45 (network) jack. To connect your notebook to a network, you need a standard network cable with an RJ-45 connector at each end. A network cable can be purchased from most computer or electronics retailers.

Some network cables contain noise suppression circuitry, which prevents interference from television and radio reception. When you connect a network cable with noise suppression circuitry ❷, orient the circuitry end ❶ of the cable toward the notebook.

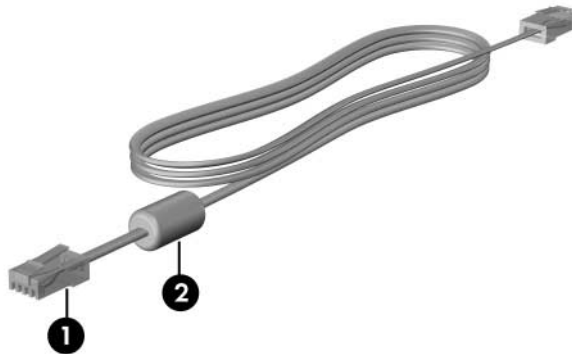

Network cables vary in appearance.

Using the Network Cable

To connect a network cable:

1. Plug the network cable into the RJ-45 (network) jack **1** on the notebook.
2. Plug the other end of the cable into a network wall jack **2**.

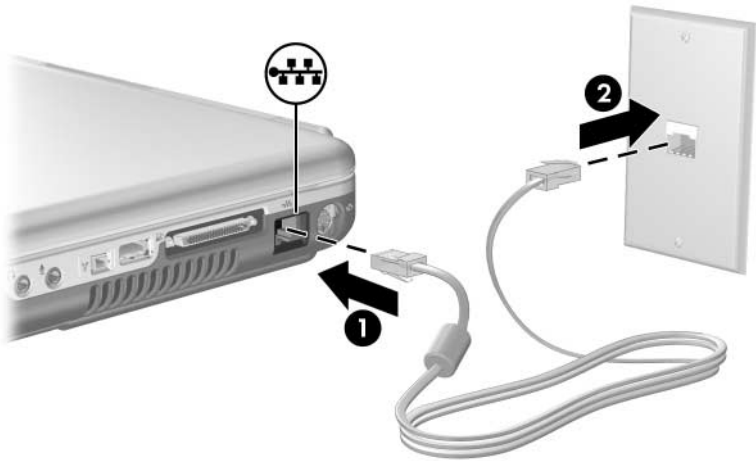

Network jacks and network cables vary in appearance.

Wireless (Select Models Only)

If your notebook is equipped with an integrated wireless device, such as 802.11 or Bluetooth wireless devices, you have a wireless notebook.

- An 802.11 wireless notebook can connect to wireless networks in corporate offices, your home, and public places. Wireless networks include wireless local area networks (WLANs) or “hotspots.” Hotspots are wireless access points available in public places, such as airports, restaurants, coffee shops, hotels, and universities.
- A Bluetooth wireless notebook can connect to other Bluetooth wireless-enabled devices using a wireless personal area network (PAN).

Your notebook has a button that can be used to enable and disable the 802.11 and Bluetooth wireless devices and an associated light to indicate the state of the wireless devices. The following illustration shows the wireless button ❶ and light ❷.

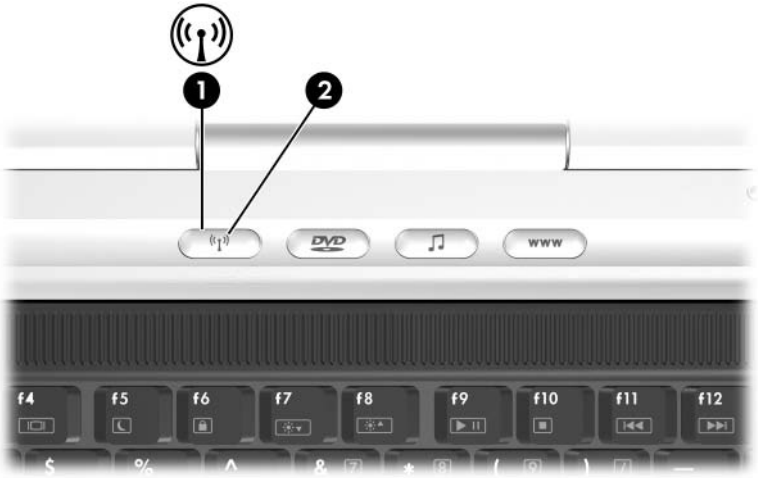

In addition to the wireless button and light, your notebook has a software utility, Wireless Assistant, that enables you to control your wireless devices. Wireless Assistant is a software utility that enables you to turn on and off the 802.11 and Bluetooth wireless devices individually. For more information about using Wireless Assistant, refer to [“Device Power States,”](#) later in this chapter.

Wireless Local Area Network (Select Models Only)

With the 802.11 wireless device, you can access a wireless local area network (WLAN), which is composed of other computers and accessories linked by a wireless router or a wireless access point.

- A large scale WLAN, such as a corporate WLAN or public WLAN hotspot, typically uses wireless access points that can handle a large number of computers and accessories and can separate critical network functions.
- A home or small office WLAN typically uses a wireless router, which enables several wireless and wired computers to share an Internet connection, a printer, and files without additional pieces of hardware or software. *Wireless access point* and *wireless router* are often used interchangeably.

Notebooks with 802.11 wireless devices may support one or more of three IEEE physical layer standards:

- 802.11a
- 802.11b
- 802.11g

There are three popular implementations of WLAN adapters:

- 802.11b only
- 802.11b/g
- 802.11a/b/g

802.11b, the first popular WLAN standard, supports data rates of up to 11 Mbps and operates at a frequency of 2.4 GHz. 802.11g, which came later, also operates at 2.4 GHz but supports data rates of up to 54 Mbps. An 802.11g wireless device is backward compatible with 802.11b devices, so they can operate on the same network. 802.11a supports data rates of up to 54 Mbps but operates at a frequency of 5 GHz. 802.11a is not compatible with 802.11b and 802.11g. For information about identifying the type of device in your notebook, refer to [“Identifying an 802.11 wireless device,”](#) later in this chapter.

Setting Up a WLAN in Your Home

To set up a WLAN and connect to the Internet in your home, you need the following equipment:

- An optional broadband modem (either DSL or cable) and high-speed Internet service purchased from an Internet service provider (ISP) ❶.
- An optional wireless router (purchased separately) ❷.
- Your wireless notebook ❸.

The following illustration shows an example of a completed wireless network installation that is connected to the Internet.

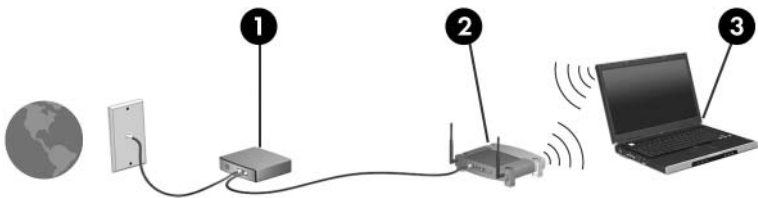

As this network grows, additional wireless and wired computers can be connected to the network to access the Internet.



If you need technical assistance to install your WLAN, contact the router manufacturer or your ISP.

Using a WLAN Connection

To use a WLAN connection:

- Verify that all drivers required by the 802.11 wireless device are installed and that the 802.11 wireless device is correctly configured.
 -  If you are using an integrated 802.11 wireless device, all required drivers are installed and the adapter is preconfigured and ready for use.
- If you are using an integrated 802.11 wireless device, verify that the 802.11 wireless device is turned on. When the 802.11 wireless device is turned on, the wireless light is turned on. If the wireless light is off, turn on the 802.11 wireless device. Refer to “[Device Power States](#),” later in this chapter.
- For your home WLAN, verify that your router is correctly configured. For instructions, refer to your router documentation.



The functional range for subsequent WLAN connections may vary, depending on your notebook WLAN implementation, router manufacturer, and interference from varying types of walls and other electronic devices.

For more information about using a WLAN connection:

- Refer to information from your ISP and the documentation included with your wireless router and other WLAN equipment.
- Access the information and Web site links provided at **Start > Help and Support**.
- Refer to the documentation included with your notebook.

Using Wireless Security Features

When you set up your own WLAN or access an existing WLAN, always ensure that security features are protecting the WLAN. If you do not enable security on your WLAN, an unauthorized wireless user can access your notebook data and use your Internet connection without your knowledge.

The most common security levels are Wi-Fi Protected Access (WPA)-Personal and Wired Equivalent Privacy (WEP). In addition to enabling WPA-Personal or WEP security encryption on the router, you may want to use one or more of the following security measures:

- Change the default network name (SSID) and password.
- Use a firewall.
- Set security on your Web browser.
- Enable MAC address filtering on the router.

For more information about WLAN security, visit the HP Web site at <http://www.hp.com/go/wireless>.

Installing Wireless Software (Optional)

Microsoft Windows XP supports WLAN configuration with the Zero Client Configuration feature. HP provides a separate WLAN configuration utility that must be installed if you plan to use Cisco Compatible Extensions. Cisco Compatible Extensions enable wireless devices to use Cisco-based WLANs.

Identifying an 802.11 wireless device

To install HP WLAN software for an integrated 802.11 wireless device, you need to know the name of the integrated 802.11 wireless device on your notebook. To identify an integrated 802.11 wireless device:

1. Display the names of all the 802.11 wireless devices on your notebook:
 - a. Select **Start > My Computer**.
 - b. Right-click the My Computer window.
 - c. Select **Properties > Hardware tab > Device Manager > Network Adapters**.
2. Identify the 802.11 wireless device from the list that is displayed:
 - The listing for an 802.11 wireless device includes the term *wireless LAN*, *WLAN*, or *802.11*.
 - If no 802.11 wireless device is listed, either your notebook does not have an integrated 802.11 wireless device, or the driver for the 802.11 wireless device is not properly installed.

Accessing WLAN Software and Documentation

Your WLAN software is preloaded on your notebook and is available in the Software Setup utility.

To install the WLAN software:

- » Select **Start > All Programs > Software Setup**, and then follow the instructions on the screen.

(When you are prompted to select the software you want to install, select or clear the corresponding check boxes.)

The WLAN software is also available as a SoftPaq at the HP Web site. To access, download, and install the SoftPaq, use either of the following procedures:

■ Select **Start > Help and Support**.

– or –

■ Visit the HP Web site at <http://www.hp.com/support>:

- a. Choose your language and region.
- b. Select the **Download Drivers and Software** radio button
- c. Enter your computer model information, and then follow the instructions provided at the Web site.



WLAN software is provided in the Network category. To access model information about your computer, refer to the Service Tag label on the bottom of your notebook.

To access documentation for your WLAN software:

1. Install the WLAN software as instructed earlier in this chapter.
2. Open the utility.
3. Select **Help** on the menu bar.

Troubleshooting Devices

For more troubleshooting information, visit the HP Web site at <http://www.hp.com/go/wireless> or refer to the user guides included with your notebook.

Bluetooth (Select Models Only)

The Bluetooth device provides short-range wireless communications that replace the physical cable connections that traditionally link electronic devices such as

- Network access points.
- Computers (desktop, notebook, PDA).
- Phones (cellular, cordless, smart phone).
- Imaging devices (printer, camera).
- Audio devices (headset, speakers).

The devices are represented in the Bluetooth for Windows software by graphical icons that resemble their physical features, which makes them easily recognizable and distinguishes them from other classes of devices.

The Bluetooth for Windows software provides the following functions:

- Personal Information Management (PIM) item transfer—Sends and receives information files such as business cards, calendar items, notes, and message items to and from another Bluetooth computer or device.
- PIM synchronization—Synchronizes PIM data between a computer, PDA, or cell phone using Bluetooth.
- File Transfer—Sends and receives files to and from another Bluetooth computer.
- Network access (Personal Area Networking Profile)—Enables two or more Bluetooth devices to form an ad-hoc (peer-to-peer) network. Provides a mechanism that enables a Bluetooth device to access a remote network through a network access point. The network access points can be traditional LAN data access points or group ad-hoc networks that represent a set of devices that are attached only to one another.

- Dial-up networking—Connects Bluetooth devices to the Internet.
- Bluetooth serial port—Transfers data over the Bluetooth link using a virtual COM port.
- Hands-Free—Enables a vehicle-embedded, hands-free unit or a notebook serving as a hands-free unit to establish a wireless connection to a cellular phone and to act as the Bluetooth cellular phone audio input and output mechanism.
- Basic imaging—Provides a wireless connection between a Bluetooth-enabled camera and other Bluetooth devices. The camera can be controlled remotely by a notebook, and images can be transferred from a camera to be stored on a computer or to be printed.
- Human interface device—Provides a wireless connection to other Bluetooth devices, such as keyboards, pointing devices, gaming devices, and remote monitoring devices.
- Fax—Provides a Bluetooth connection that enables a notebook to send or receive a fax message using a Bluetooth cellular phone or modem.
- Headset—Provides a wireless connection between a headset and a notebook or cellular phone. The headset acts as the device's audio input and output mechanism and increases mobility.

For more information about using Bluetooth with your notebook, refer to the Help and Support Center at Start > Help and Support.

Device Power States

The wireless button ❶ enables and disables 802.11 wireless and Bluetooth devices in conjunction with Wireless Assistant. By default, the 802.11 wireless and Bluetooth devices and wireless light ❷ are turned on when you turn on the notebook.



Turning on a wireless device does not automatically create a WLAN or connect you to a WLAN. For information about setting up a WLAN refer to [“Wireless Local Area Network \(Select Models Only\),”](#) earlier in this chapter.

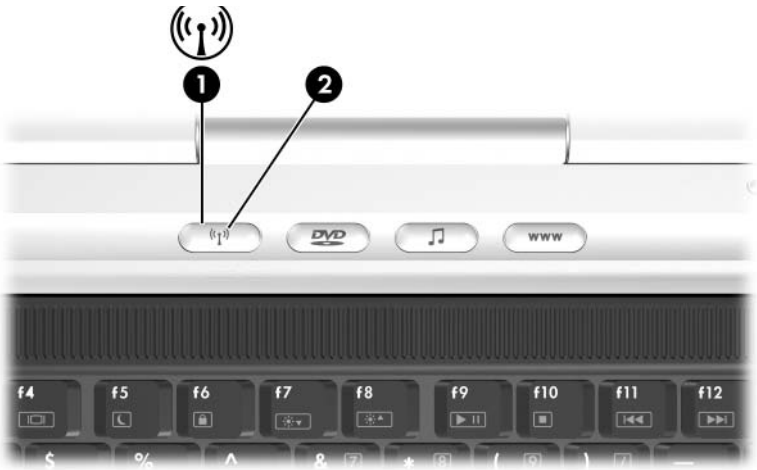

The 802.11 wireless and Bluetooth devices have two power states:

- Enabled
- Disabled

You can enable and disable the wireless devices with the wireless button. When the wireless devices are enabled with the wireless button, you can use Wireless Assistant to turn on and off the devices individually. When the wireless devices are disabled, you must enable them before you can turn them on or off with Wireless Assistant.

To view the state of your wireless devices, place the cursor over the **Wireless Assistant** icon in the notification area, or open Wireless Assistant by double-clicking the icon in the notification area. Wireless Assistant displays the status of the devices as on, off, or disabled.

For more information about Wireless Assistant:

1. Open Wireless Assistant by double-clicking the icon in the notification area.
2. Select the **Help** button.

Turning On the Devices

If	And	Then
<ul style="list-style-type: none"> ■ Wireless Assistant shows that both WLAN and Bluetooth are off ■ Wireless light is off 	You want to turn on either or both devices	<ol style="list-style-type: none"> 1. Right-click the Wireless Assistant icon in the notification area. 2. Select the device or devices you want to turn on. <p> If the wireless devices are turned off, pressing the wireless button disables both devices. The button does not turn on the devices.</p>
<ul style="list-style-type: none"> ■ Wireless Assistant shows that both WLAN and Bluetooth are disabled* ■ Wireless light is off 	You want to turn on either or both devices	<ol style="list-style-type: none"> 1. Press the wireless button. (The devices return to their previous on or off state.) 2. If the wireless devices are turned off, right-click the Wireless Assistant icon in the notification area. 3. Select the device or devices you want to turn on.
<ul style="list-style-type: none"> ■ Wireless Assistant shows that one device is on and the other device is off ■ Wireless light is on 	You want to turn on either or both devices	<ol style="list-style-type: none"> 1. Right-click the Wireless Assistant icon in the notification area. 2. Select the device or devices you want to turn on.

*If the wireless devices are not both on when you disable the devices, pressing the wireless button again returns the devices to their previous on or off state. Pressing the button does not turn on both devices.



If you want your wireless devices to be turned on when you turn on your notebook, you must turn them on before you shut down or restart your notebook.

Turning Off and Disabling the Devices

If	And	Then
■ Wireless Assistant shows that both WLAN and Bluetooth are on	You want to disable both devices	Press the wireless button.
	You want to turn off either or both devices	<ol style="list-style-type: none">1. Right-click the Wireless Assistant icon in the notification area.2. Select the device or devices you want to turn off.
■ Wireless light is on		
■ Wireless Assistant shows that both WLAN and Bluetooth are off	You want to disable both devices	Press the wireless button.
■ Wireless light is off		
■ Wireless Assistant shows that one device is on and the other device is off*	You want to disable both devices	Press the wireless button.
	You want to turn off both devices.	<ol style="list-style-type: none">1. Right-click the Wireless Assistant icon in the notification area.2. Select the device or devices you want to turn off.
■ Wireless light is on		

*If the wireless devices are not both on when you disable the devices, pressing the wireless button again returns the devices to their previous on or off state. Pressing the button does not turn on both devices.

Security Features



Security solutions are designed to act as deterrents. These deterrents may not prevent a product from being mishandled or stolen.

You can use the security features provided with your notebook to protect your notebook, personal information, and data from a variety of risks. Depending on how and where you use your notebook, you may not need to use all of these features.

It is recommended that you follow the procedures provided in this chapter for using

- AntiVirus software.
- Windows updates.
- Firewall software.

The table next in this chapter may help you decide which other security features to use.

To Protect Against	Use This Security Feature
Unauthorized use of the notebook	<ul style="list-style-type: none"> ■ QuickLock ■ Power-on password*
Unauthorized access to the Setup utility (f10)	HP administrator password*
Unauthorized access to the contents of a hard drive	DriveLock*
Unauthorized startup from a CD, DVD, or diskette	Device Security*
Unauthorized access to data	<ul style="list-style-type: none"> ■ HP administrator password* ■ Windows security updates ■ Firewall software
Unauthorized access to the BIOS settings and other system identification information	HP administrator password*
Computer viruses	Norton AntiVirus software
Unauthorized removal of the notebook	Security cable slot (used with an optional security cable) For more information about the security cable slot, refer to "Optional Security Cable," later in this chapter.

*This security feature is configured in the Setup utility. The Setup utility is a non-Windows utility accessed by pressing **f10** when the notebook is turned on or restarted. The procedures for using the Setup utility to set specific security preferences are provided in this chapter. For information about displaying system information and using other Setup utility features, refer to [Chapter 13, "Setup Utility."](#)

Security Preferences in the Setup Utility

Most security preferences are set in the Setup utility. Because the Setup utility is a non-Windows utility, it does not support the pointing devices on your notebook. When using the Setup utility, you must use the keys on your notebook to navigate and to make selections. For more information about using the Setup utility, refer to [Chapter 13, “Setup Utility.”](#)

QuickLock

The **fn+f6** hotkey initiates the QuickLock security feature.

QuickLock protects a Windows account by displaying a log on window. To access the protected account from the log on window, the Windows password for the protected account must be entered.

Before you can use QuickLock, you must set a Windows user password or a Windows administrator password for the account you want to protect. (A Windows user password protects a Windows user account; a Windows administrator password protects a Windows administrator account.)

To set password for a Windows account:

1. Select **Start > Control Panel > User Accounts > User Accounts**.
2. Select the account.
3. Select **Create a password**, and then follow the instructions on the screen.



If the account is already protected by a Windows password, the Create a password link is not displayed. You can lock and unlock the account as described next in this section by using the existing password.

After you have set a Windows password for a Windows account, you can protect the account with a log on window whenever the account is active.

- To lock the account, press **fn+f6**.
- To unlock the account from the log on window:
 - a. Select the account (if more than one account is displayed)
 - b. Type the account password in the password text field.
 - c. Press **enter**.

When a Windows password is set for a Windows account, you must enter the password to access the account each time the notebook is turned on or restarted.

To access procedures for changing or deleting Windows passwords and for using password hints:

- » Select **Start > Control Panel > User Accounts > User Accounts**.

For more information about using hotkeys, including information about using hotkeys on an external keyboard, refer to “[Hotkeys](#)” in [Chapter 3, “Keyboard.”](#)

For information about combining Windows passwords with HP passwords, refer to “[HP and Windows Passwords](#),” later in this chapter.

Passwords

Most security features use passwords. Whenever you set a password, write down the password and store it in a secure location away from the notebook.

- If you forget your power-on password and your HP administrator password, you cannot start up the notebook or restore from hibernation. Call Customer Care or your service partner for additional information.
- If you forget your HP administrator password, you will not be able to access the Setup utility.
- If you forget a DriveLock password, the hard drive protected by the password is permanently locked and can no longer be used.

HP and Windows Passwords

HP security features and Windows operating system security features work independently from one another. For example, a device disabled in the Setup utility cannot be enabled in Windows.

HP passwords and Windows passwords are also independent of one another.

- *HP passwords* are passwords which are set in software provided by HP. For example, all passwords set in the Setup utility are HP passwords.
- *Windows passwords* are passwords which are set in your Windows operating system.

The following table lists commonly used HP and Windows passwords and describes their functions.

HP Passwords	Function
HP administrator password	Used to access the Setup utility.
Power-on password	Used to access notebook contents when the notebook is turned on, restarted, or restored from hibernation.
DriveLock password	Used to access a drive protected by DriveLock when the notebook is turned on restarted from the protected hard drive.
Windows Passwords	Function
Administrator password	Protects Windows administrator-level access to notebook contents.
User password	Protects access to a Windows user account.
Standby password	Protects access to notebook contents when the notebook is resumed from standby or restored from hibernation.

For information about

- Setting the Windows passwords listed in the table and about using additional Windows passwords, such as screen-saver passwords, select **Start > Help and Support**. Instructions for using a standby password are also provided in this guide. Refer to [“Using a Security Password”](#) in [Chapter 2](#), [“Power.”](#)
- Using Windows user accounts, refer the printed *Getting Started* book included with your notebook.
- Using a Windows user password or a Windows administrator password with QuickLock, refer to [“QuickLock,”](#) earlier in this chapter.
- Coordinating HP and Windows passwords, refer to the password guidelines section, next in this chapter.

HP and Windows Password Guidelines

Choosing Your Passwords

You can use the same text for HP passwords and Windows passwords, with the following considerations:

- The text of HP passwords can be any combination of up to 8 letters and numbers and is not case sensitive.
- An HP password must be set and entered with the same type of keys.

For example, an HP password set with keyboard number keys will not be recognized if it is entered with embedded numeric keypad number keys. For information about the embedded numeric keypad, refer to [“Using the Embedded Numeric Keypad”](#) in [Chapter 3, “Keyboard.”](#)

Any text used for a an HP password can be used for a Windows password. For more information about choosing a Windows password, select **Start > Help and Support**.

Coordinating Your Passwords

Although you can use the same text for various passwords, HP passwords and Windows passwords function independently.

- Even if you plan to use the same text for an HP password and a Windows password, you must set the HP password in the Setup utility and the Windows password in your operating system.
- Unless you choose identical text for your HP passwords and your Windows passwords, you must enter the text of your HP password at an HP password prompt and the text of your Windows password at a Windows password prompt. For example:
 - ❑ If a power-on password is set, your power-on password (not a Windows password) must be entered when the notebook is turned on, restarted, or restored from hibernation.
 - ❑ If a Windows standby password is set, your Windows password (not your power-on password) must be entered when the notebook is resumed from standby or restored from hibernation.



Although their names are similar, an HP administrator password and a Windows administrator password have different functions. For example, a Windows administrator password cannot be used to access the Setup utility, and an HP administrator password cannot provide administrator-level access to your notebook contents. You can, however, use the same text for both passwords.

HP Administrator Passwords

The HP administrator password protects the configuration settings and system identification information in the Setup utility. After this password is set, it must be entered to access the Setup utility.

The HP administrator password

- Is not interchangeable with a Windows administrator password, although both can use the same word or series of letters and numbers.
- Can include any combination of up to 8 letters and numbers and is not case sensitive.
- Does not display as it is set, entered, changed, or deleted.
- Must be set and entered with the same keys. For example, an HP administrator password set with keyboard number keys will not be recognized if you enter it with embedded numeric keypad number keys.

For more information about the system identification information in the Setup utility, refer to [“System Information”](#) in [Chapter 13](#), [“Setup Utility.”](#)

Setting HP Administrator Passwords

An HP administrator password is set, changed, or deleted in the Setup utility.

To manage the password:

1. If you are not sure whether the notebook is off or in hibernation, press the power button. (The notebook turns on or restores from hibernation.)
2. Display the Setup message.
 - ❑ If the notebook is on, restart the notebook through the operating system.
 - ❑ If you are certain that the notebook is off and not in hibernation, turn the notebook on.
3. Press **f10** while the Setup message is displayed in the lower-left corner of the screen.
4. Use the arrow keys to select **Security > Administrator Password**, and then press **enter**.
 - ❑ To set an HP administrator password, type your password in the **Enter New Password** and **Confirm New Password** fields, and then press **enter**.
 - ❑ To change an HP administrator password, type your current password in the **Enter Current Password** field, type the new password in the **Enter New Password** and **Confirm New Password** fields, and then press **enter**.
 - ❑ To delete an HP administrator password, type your current password in the **Enter Password** field, press **enter** 3 times, and then press **f10**.
5. To save your preferences and exit the Setup utility, press **f10**, and then follow the instructions on the screen.

Your preferences are in effect when the notebook restarts.

Entering HP Administrator Passwords

At the Enter SETUP prompt, type your HP administrator password, and then press **enter**. After 3 unsuccessful attempts to enter the HP administrator password, you must restart the notebook and try again.

Power-On Passwords

A power-on password prevents unauthorized use of the notebook. After this password is set, it must be entered each time the notebook is turned on, restarted, or restored from hibernation.

A power-on password

- Does not display as it is set, entered, changed, or deleted.
- Must be set and entered with the same keys. For example, a power-on password set with keyboard number keys will not be recognized if you enter it with embedded numeric keypad number keys.
- Can include any combination of up to 8 letters and numbers and is not case sensitive.

Setting Power-On Passwords

A power-on password is set, changed, or deleted in the Setup utility.

To manage the password:

1. If you are not sure whether the notebook is off or in hibernation, press the power button. (The notebook turns on or restores from hibernation.)
2. Display the Setup message.
 - ❑ If the notebook is on, restart the notebook through the operating system.
 - ❑ If you are certain that the notebook is off and not in hibernation, turn the notebook on.

3. Press **f10** while the Setup message is displayed in the lower-left corner of the screen.
4. Use the arrow keys to select **Security > Power-On password**, and then press **enter**.
 - ❑ To set a power-on password, type the password in the **Enter New Password** and **Confirm New Password** fields, and then press **enter**.
 - ❑ To change a power-on password, type the current password in the **Enter Current Password** field, type the new password in the **Enter New Password** and **Confirm New Password** fields, and then press **enter**.
 - ❑ To delete a power-on password, type the current password in the **Enter Current Password** field, press **enter** 3 times, and then press **f10**.
5. To save your preferences and exit the Setup utility, press **f10**, and then follow the instructions on the screen.

Your preferences are in effect when the notebook restarts.

Entering Power-On Passwords

At the power-on password prompt, type your password, and then press **enter**. After 3 unsuccessful attempts to enter the password, you must restart the notebook and try again.

DriveLock



CAUTION: To protect your use of a hard drive protected by DriveLock, record the DriveLock password in a safe place away from your notebook. If you forget the DriveLock password, the hard drive is permanently locked and can no longer be used.

DriveLock prevents unauthorized access to the contents of a hard drive.

DriveLock protection can be applied only to the primary hard drive. The primary hard drive is the hard drive in the hard drive bay of the notebook.

To apply DriveLock protection to a drive, a DriveLock password must be set in the Setup utility:

- After a DriveLock password is set, it must be entered each time the notebook is turned on or restarted from the hard drive protected by DriveLock.
 - You can delete a DriveLock password only by removing DriveLock protection from the drive. For instructions, refer to [“Removing DriveLock Protection,”](#) later in this chapter.
 - A hard drive protected by DriveLock can only be accessed by using the DriveLock password.
-



If you set both a power-on password and a DriveLock password, you are prompted for both passwords when you start or restart the notebook from a hard drive protected with DriveLock. Even if your power-on password and your DriveLock password are identical, you must enter your power-on password at the power-on password prompt and then enter your DriveLock password at the DriveLock password prompt.

Setting DriveLock Passwords

To set a DriveLock password:

1. If you are not sure whether the notebook is off or in hibernation, press the power button. (The notebook turns on or restores from hibernation.)
2. Display the Setup message.
 - ❑ If the notebook is on, restart the notebook through the operating system.
 - ❑ If you are certain that the notebook is off and not in hibernation, turn the notebook on.
3. Press **f10** while the Setup message is displayed in the lower-left corner of the screen.
4. Use the arrow keys to select **Security > DriveLock Password**, and then press **enter**.
5. Read the warning, and then press **enter**.
6. Type the new password in the **Enter New Password** field, and then press **enter**.
7. Type the new password in the **Confirm New Password** field, and then press **enter**.
8. To confirm DriveLock protection on the drive you have selected, type DriveLock in the confirmation field, and then press **f10**.
9. Press **enter** to continue.
10. To save your preferences and exit the Setup utility, press **f10**, and then follow the instructions on the screen.

Your preferences are in effect when the notebook restarts.

Entering DriveLock Passwords

At the DriveLock password prompt, type the DriveLock password in the **Enter DriveLock Password** text field, and then press **enter**.

After 3 unsuccessful attempts to enter the password, the warning message “HDD is locked now!” is displayed. When the message is displayed:

- If you restart your notebook, you can try again to enter your DriveLock password.
- If you press **enter**, the notebook tries to start from another bootable device in the system. At default settings, the notebook will try to start from the following devices in the sequence listed:
 - ❑ A bootable diskette
 - ❑ A bootable disc
 - ❑ A network adapter

Advanced users can use settings in the Setup utility to change this sequence.

Changing DriveLock Passwords

To change a DriveLock password:

1. If the notebook is on, shut down the notebook.

If the notebook is not on and you are not sure whether the notebook is off or in hibernation, press the power button. When the notebook has turned on or restored from hibernation, shut down the notebook through the operating system.

2. Turn on the notebook.
3. Press **f10** while the Setup message is displayed in the lower-left corner of the screen.
4. Use the arrow keys to select **Security > DriveLock Password**, and then press **enter**.
5. Type the current password in the **Enter Current Password** field, and then press **enter**.
6. Type the new password in the **Enter New Password** field, and then press **enter**.
7. Type the new password in the **Confirm New Password** field, and then press **enter**.
8. When the Setup Notice is displayed, press **enter** to save your changes.
9. To save your preferences and exit the Setup utility, press **f10**, and then follow the instructions on the screen.

Your preferences are in effect when the notebook restarts.

Removing DriveLock Protection

To access the DriveLock settings in the Setup utility:

1. If the notebook is on, shut down the notebook.
If the notebook is not on and you are not sure whether the notebook is off or in hibernation, press the power button and then shut down the notebook through the operating system.
2. Turn on the notebook.
3. Press **f10** while the Setup message is displayed in the lower-left corner of the screen.
4. Use the arrow keys to select **Security > DriveLock Password**, and then press **enter**.
5. Type the current password in the **Enter Current Password** field, and then press **enter** 3 times. (Pressing enter at each of the remaining password fields indicates that you are removing, not changing, the password.)
6. When the Setup Notice is displayed, press **enter** to save your changes.
7. To save your preferences and exit the Setup utility, press **f10**, and then follow the instructions on the screen.

Your preferences are in effect when the notebook restarts.

Device Security

From the Setup utility Device Security menu, you can disable the ability of the notebook to start from a CD, DVD, or diskette.

To disable or reenable these notebook capabilities in the Setup utility:

1. If you are not sure whether the notebook is off or in hibernation, press the power button. (The notebook turns on or restores from hibernation.)
2. Display the Setup message.
 - ❑ If the notebook is on, restart the notebook through the operating system.
 - ❑ If you are certain that the notebook is off and not in hibernation, turn the notebook on.
3. Press **f10** while the Setup message is displayed in the lower-left corner of the screen.
4. Select **Security > Device Security**, and then press **enter**.
5. Use the arrow keys to select an item. Then:
 - ❑ To disable an item, press **f5** or **f6** to toggle the field for the item to **Disable**, and then press **enter**.
 - ❑ To reenable an item, press **f5** or **f6** to toggle the field for the item to **Enable**, and then press **enter**.
6. When a confirmation prompt with your preference selected is displayed, press **enter** to save your preference.
7. To save your preferences and exit the Setup utility, press **f10**, and then follow the instructions on the screen.

Your preferences are in effect with the notebook restarts.

Antivirus Software

When you use the notebook for e-mail, network, or Internet access, you expose the notebook to computer viruses. Computer viruses can disable your operating system, applications, or utilities, or cause them to function abnormally.

Antivirus software can detect most viruses, destroy them, and, in most cases, repair damage they have caused. To provide protection against newly discovered viruses, antivirus software must be updated.

Norton AntiVirus software is preinstalled on your notebook.

- Your version of Norton AntiVirus software includes 60 days of free updates. It is strongly recommended that you protect your notebook against new viruses beyond 60 days by purchasing extended update service.
- Instructions for using and updating your Norton AntiVirus software and for purchasing extended update service are provided within the application.
- To access your Norton AntiVirus software, select **Start > All Programs > Norton AntiVirus**.

Critical Security Updates for Windows XP



CAUTION: To protect the contents of your notebook from newly-discovered security breaches and computer viruses, it is recommended that you install every *critical* update from Microsoft as soon as you receive the critical update alert. You should also run Windows Update on a monthly basis to install the latest *recommended* updates from Microsoft.

A *Critical Security Updates for Windows XP* disc may be included with your notebook. This disc contains updates made available after your notebook was configured but before your notebook was shipped.

To update your system using the *Critical Security Updates for Windows XP* disc:

1. Insert the disc into your optical drive.
2. Follow the instructions on the screen to install all updates. This may take a few minutes.
3. Remove the disc.

Additional updates to your operating system and other software included on your notebook may have become available after your notebook was shipped.

To be certain that all available updates are installed on your notebook:

» Use the update link at **Start > Help and Support**.

Throughout the life of your notebook, updates to Windows and Microsoft applications will continue to become available. You can obtain these updates from the Microsoft Web site as well as through the update link the Help and Support utility.

Firewall Software

When you use the notebook for e-mail, network, or Internet access, it is possible for unauthorized persons to obtain information about you, your notebook, and your data. To protect your privacy, it is recommended that you use firewall software.

Firewall software monitors all incoming and outgoing traffic on your notebook and includes features such as logging and reporting, automatic alarms, and displays that you can use to configure the firewall.

The Windows operating system firewall is available on your notebook and is enabled by default. To learn more about this firewall or to disable or reenabte this firewall:

1. Select **Start > Control Panel > Network and Internet Connections > Windows Firewall**.
2. Select the **General** tab.
 - To learn more about Windows Firewall, select the **What else should I know about Windows Firewall?** link.
 - To disable Windows Firewall, select **Off (not recommended)**.
 - To reenabte Windows Firewall, select **On (recommended)**.
3. Select **OK**.



Under some circumstances a firewall can block access to Internet games, interfere with printer or file sharing on a network, or block authorized e-mail attachments. To temporarily solve the problem, disable the firewall, perform the task that is interfering with the firewall, and then reenabte the firewall. To permanently resolve the problem, reconfigure the firewall.

Optional Security Cable

An optional security cable is a security device that can prevent unauthorized removal of the notebook.

To attach and lock a security cable:

1. Insert the cable lock key ❶ into the cable lock.
2. Loop the security cable ❷ around a secured object.
3. Insert the cable lock into the security cable slot ❸, and then lock the cable lock with the cable lock key.

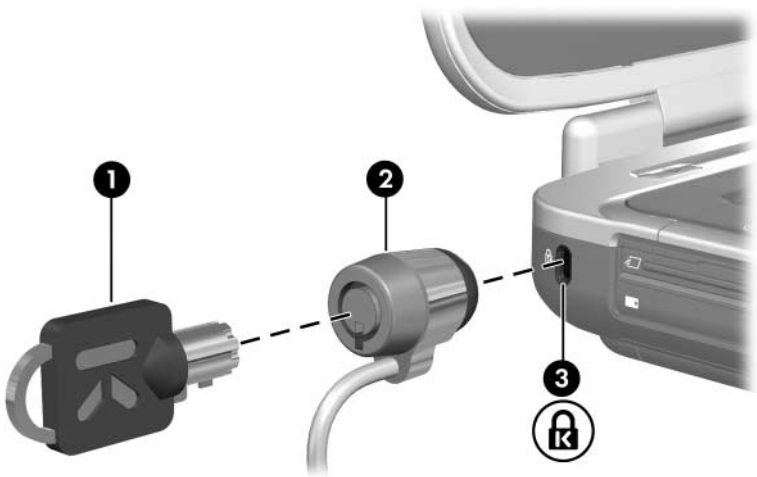

Setup Utility

What Is the Setup Utility?

The Setup utility is a ROM-based information and customization utility that can be used even when your operating system is not working or does not load.

The utility reports information about the notebook and provides settings for startup, security, and other preferences.

Step-by-step instructions for setting specific preferences in the Setup utility are included by topic throughout this guide. For example, procedures for setting password and other security preferences are provided in [Chapter 12, “Security.”](#)



You can set additional system preferences, such as icon display preferences, in the Quick Launch button software. For information about using this software, refer to [“Quick Launch Buttons Software”](#) in [Chapter 3, “Keyboard.”](#)

Open the Setup Utility

The Setup utility is accessed through the Setup message. The Setup message is “Press <F10> to enter setup.”

The Setup message is displayed only when the notebook is turned on or restarted. The message is not displayed when the notebook is restored from hibernation.

The message is displayed briefly, before Windows opens, in the lower-left corner of your screen.

To open the Setup utility:

1. Display the Setup message.
 - If the notebook is on and in Windows, restart the notebook.
 - If the notebook is off, turn on the notebook.
 - If the notebook is in hibernation, restore the notebook from hibernation, and then restart the notebook.
 -  If you are not sure whether the notebook is off or in hibernation, press the power button. Then if the notebook opens in Windows, restart the notebook. If the notebook opens in a non-Windows application or utility, such as the Setup utility, shut down and then turn on the notebook.
2. Press **f10** while the Setup message is displayed.

Setup Utility Language

The following procedure explains how to change the language of the Setup utility. If the notebook is not in the Setup utility, begin at step 1. If the notebook is in the Setup utility, begin at step 3.

1. If you are not sure whether the notebook is off or in hibernation, press the power button. (The notebook is turned on or restored from hibernation.)
2. Display the Setup message:
 - ❑ If the notebook is on, restart the notebook through the operating system.
 - ❑ If you are certain that the notebook is off and not in hibernation, turn the notebook on.
3. Press **f10** while the Setup message is displayed.
4. Use the arrow keys to select the **Advanced** menu.
5. Use the arrow keys to select **Language Support**.
6. Press **f5** or **f6** to select a language.
7. To set your preferences and exit the Setup utility, press **f10** and then follow the instructions on the screen. Your preferences are in effect when the notebook restarts in Windows.

Navigation and Item Selection

Because the Setup utility is not Windows-based, it does not support the TouchPad. Navigation and selection are by keystroke.

- To choose a menu or a menu item, use the arrow keys.
- To choose an item in a drop-down list or to toggle a field, for example an Enable/Disable field, use either the arrow keys or **f5** or **f6**.
- To select an item, press **enter**.
- To close a text box or return to the menu display, press **esc**.

An on-screen guide to navigation and selection is displayed at the lower edge of most Setup utility submenu screens. To display additional navigation and selection information while the Setup utility is open, press **f1**.

System Information

The following procedure explains how to display system information in the Setup utility. If the Setup utility is not open, begin at step 1. If the Setup utility is open, begin at step 3.

1. If you are not sure whether the notebook is off or in hibernation, press the power button. (The notebook turns on or restores from hibernation.)
2. Display the Setup message:
 - ❑ If the notebook is on, restart the notebook through the operating system.
 - ❑ If you are certain that the notebook is off and not in hibernation, turn the notebook on.
3. Press **f10** while the Setup message is displayed in the lower-left corner of the screen.

4. Access the system information on the **Main** and **Advanced** menus.
 - ❑ To display most of the system information available in the Setup utility, use the arrow keys to select the **Main** menu.
 - ❑ To display video memory information, use the arrow keys to select the **Advanced** menu.
5. To close the Setup utility without changing any settings, use the arrow keys to select the **Exit** menu > **Exit Discarding Changes**, and then press **enter**. (The notebook restarts in Windows.)

Default Settings

The following procedure explains how to restore the Setup utility default settings. If the notebook is not in the Setup utility, begin at step 1. If the notebook is in the Setup utility, begin at step 3.

1. If you are not sure whether the notebook is off or in hibernation, press the power button. (The notebook turns on or restores from hibernation.)
2. Display the Setup message:
 - ❑ If the notebook is on, restart the notebook through the operating system.
 - ❑ If you are certain that the notebook is off and not in hibernation, turn the notebook on.
3. Press **f9**.
4. When the Setup Confirmation is displayed, press **enter** to save your preference.
5. To set your preference and exit the Setup utility, press **f10**, and then follow the instructions on the screen.

The Setup utility default settings are set when you exit the Setup utility and are in effect when the notebook restarts in Windows. Identification information, including ROM version information, is retained.

Advanced Features

This guide describes the Setup utility features recommended for all users. For more information about the Setup utility features recommended for advanced users only, refer to the Help and Support Center by selecting **Start > Help and Support**.

The Setup utility features available for advanced users include:

- A hard drive self-test.
- A Network Service Boot.

The “<F12> to boot from LAN” message that is displayed in the lower-left corner of the screen each time the notebook is turned on, restarted, or restored from hibernation is the prompt for a Network Service Boot to a PreBoot eXecution Environment (PXE) server.

- Settings for boot order preferences.

The “Press <ESC> to change boot order” message that is displayed in the lower-left corner of the screen each time the notebook is turned on, restarted, or restored from hibernation is the prompt to change the boot order.

- Settings for enabling and disabling optional WLAN and Bluetooth devices.

If an optional wireless device is disabled in the Setup utility, the device cannot be controlled by using the wireless button or the Wireless Assistant utility. For more information about the wireless button and Wireless Assistant, refer to [Chapter 11, “Wireless \(Select Models Only\).”](#)

Close the Setup Utility

You can close the Setup utility with or without saving changes.

- To close the Setup utility and save your changes from the current session, use either of the following procedures:
 - Press **f10**, and then follow the instructions on the screen.
 - or –
 - If the Setup utility menus are not visible, press **esc** to return to the menu display. Then use arrow keys to select the **Exit** menu > **Exit Saving Changes**, and then press **enter**.

When you use the **f10** procedure, you are offered an option to return to the Setup utility. When you use the Exit Saving Changes procedure, the Setup utility closes when you press **enter**.

- To close the Setup utility without saving your changes from the current session:

If the Setup utility menus are not visible, press **esc** to return to the menu display. Then use arrow keys to select the **Exit** menu > **Exit Discarding Changes**, and then press **enter**.

After the Setup utility closes, the notebook restarts in Windows.

Software Updates and Recovery

Software Updates

For optimal notebook performance and to make sure your notebook remains compatible with changing technologies, install the latest versions of the software provided with your notebook as they become available.

As with any other software modification, it is strongly recommended that you set a restore point before beginning a software update. For instructions, refer to “[Using System Restore](#),” later in this chapter.

You may find that the easiest way to update the software preloaded or preinstalled on your notebook is to use the software update links provided at **Start > Help and Support**.

If you prefer to work from more detailed instructions, the supplementary information in the following sections may help you to

- Prepare for any update by identifying your notebook category, product name, product number, and serial number.
- Prepare for a ROM (read-only memory) update by identifying the ROM version currently installed on the notebook.
- Access, download, and install updates from the HP Web site.

If your notebook connects to a network, consult with your network administrator before installing any software update, particularly a ROM update.

Accessing Notebook Product Information

To access the updates for your notebook, you may need the following information:

- The product category is Notebook.
- The product name, product number (P/N), and serial number (S/N) are provided on the Service Tag. The information on the Service Tag is provided at **Start > Help and Support > My HP Computer**, and on the Service Tag label affixed to the bottom of the notebook.

Accessing Notebook ROM Information

To determine whether an available ROM update is a later ROM version than the ROM version currently installed on the notebook, you need to know the version of the currently installed ROM.



The notebook ROM stores the BIOS (basic input-output system). The BIOS determines how the notebook hardware interacts with the operating system and external devices. The BIOS also supports such notebook services as time and date.

Notebook ROM information can be displayed from within Windows or in the Setup utility.

- To display ROM information from within Windows, press the **fn+esc** hotkey.

In the **fn+esc** display, the version of the system ROM is displayed as the BIOS (basic input-output system) date. On some notebook models, the BIOS date is displayed in decimal format. To clear the display, press **esc**.

- To display ROM information in the Setup utility, follow these steps:
 1. If you are not sure whether the notebook is off or in hibernation, press the power button. (The notebook turns on or restores from hibernation.)
 2. Display the Setup message:
 - ◆ If the notebook is on, restart the notebook through the operating system.
 - ◆ If you are certain that the notebook is off and not in hibernation, turn the notebook on.
 3. While the “Press <F10> to enter Setup” message is displayed in the lower-left corner of the screen, press **f10**.
 4. If the Setup utility does not open with system information displayed, use the arrow keys to select the **Main** menu. (When the Main menu is selected, ROM and other system information is displayed.)
 5. To close the Setup utility without changing any settings, use the arrow keys to select the **Exit** menu > **Exit Discarding Changes**, and then press **enter**. (The notebook restarts in Windows.)

For more information about using the Setup utility, refer to [Chapter 13, “Setup Utility.”](#)

Internet Software



This section describes the software updates available at the HP Web site. For information about connecting to the Internet using the Internet software included with the notebook, refer to the “Connect to the Internet” section in the printed *Getting Started* guide included with your notebook.

Most software at the HP Web site is packaged in compressed files called *SoftPaqs*. Some ROM updates may be packaged in compressed files called *ROMPaqs*.

Most download packages contain a file named *Readme.txt*. A *Readme.txt* file contains detailed descriptive, installation, and troubleshooting information about the download. The *Readme.txt* files included with *ROMPaqs* are in English only.

The following sections provide instructions for downloading and installing

- A ROM update.
- A SoftPaq containing an update other than a ROM update—for example, an application update.

Downloading System ROM



CAUTION: To prevent serious damage to the notebook or an unsuccessful installation, download and install a ROM update only while the notebook is connected to reliable external power using the AC adapter. (Do not download or install a ROM update while the notebook is docked in an optional docking device or running on battery power.) During the download and installation:

- Do not unplug the notebook from the AC outlet.
 - Do not shut down the notebook or initiate standby or hibernation.
 - Do not insert, remove, connect, or disconnect any device, cable, or cord.
-

Downloading a ROM Update

To download a ROM update:

1. Access the page at the HP Web site that provides software for your notebook.
 - ❑ Select **Start > Help and Support**, and then select a software update link.
 - or –
 - ❑ Visit the HP Web site at <http://www.hp.com/support>
2. Follow the instructions on the screen to identify your notebook and access the ROM update you want to download.
3. At the download area:
 - a. Record the date, name, or other identifier of any ROM update that is later than the ROM currently installed on your notebook. (You may need this information to locate the update later, after it is downloaded to the hard drive.)
 - b. Record the path to the default or custom location on the hard drive to which the ROM package will download. (You may need to access the ROM package after it is downloaded.)
 - c. Follow the online instructions to download your selection to the hard drive.

Installing a ROM Update

ROM installation procedures vary. Follow any instructions that are displayed on the screen after the download is complete. If no instructions are displayed:

1. Open Windows Explorer. To open Windows Explorer from the **Start** button, select **Start > All Programs > Accessories > Windows Explorer**.
2. In the left pane of the Windows Explorer window:
 - a. Select **My Computer** > your hard drive designation. (The hard drive designation is typically Local Disk C.)
 - b. Follow the path you recorded earlier to the folder on your hard drive that contains the update.
3. To begin the installation, open the folder, and then double-click the file with an .exe extension—for example, Filename.exe. (The ROM update installation begins.)
4. To complete the installation, follow the instructions on the screen.



After a message on the screen reports a successful installation, you can delete the downloaded file from the destination folder.

Downloading Software

To update software other than a ROM update:

1. Access the page at the HP Web site that provides software for your notebook.
 - ❑ Select **Start > Help and Support**, and then select a software update link.
 - or –
 - ❑ Visit the HP Web site at
<http://www.hp.com/support>
2. Follow the instructions on the screen to identify your notebook and access other software you want to download.
3. At the download area:
 - a. Write down the date, name, or other identifier of the SoftPaq you plan to download. (You may need this information to locate the update later, after it has been downloaded to the hard drive.)
 - b. Follow the online instructions to download the SoftPaq to the hard drive.
4. When the download is complete, open Windows Explorer. To open Windows Explorer from the Start button, select **Start > All Programs > Accessories > Windows Explorer**.
5. In the left pane of the Windows Explorer window, select **My Computer** and then select your hard drive designation. (The hard drive designation is typically Local Disk C.)
6. Select the **SWSETUP** folder.

The destination folder for most downloads from the HP Web site is the SWSETUP folder. If you don't see the download in the SWSETUP folder, look in the My Documents folder.

7. In the folder containing your download, select the name or number of the software package you have downloaded.
8. Select the file that includes an .exe extension—for example, Filename.exe. (The installation begins.)
9. To complete the installation, follow the instructions on the screen.



After a message on the screen reports a successful installation, you can delete the downloaded file from the destination folder.

System Recovery



CAUTION: To prevent loss of notebook functionality, perform the procedures described in this section only while the notebook is connected to reliable external power through the AC adapter. During a software restoration, repair, or reinstallation:

- Do not unplug the notebook from external power.
 - Do not shut down the notebook or initiate standby or hibernation.
 - Do not insert, remove, connect, or disconnect any device, cable, or cord.
-

Before You Begin



It is recommended that you try to restore your system by using the System Restore utility before you consider repairing or reinstalling your operating system.

Perform the following restore procedures in the order presented.

Step	Description	Refer to
1	Return the notebook to a system restore point.	“Using System Restore,” later in this chapter
2	Try to solve or diagnose the problem by using the Help and Support Center.	Start > Help and Support > Fixing a problem
3	Reinstall all HP drivers.	“Repairing or Reinstalling Drivers,” later in this chapter
4	If you suspect the problem could be caused by a preinstalled or preloaded application, try reinstalling the application.	“Repairing or Reinstalling Applications,” later in this chapter
5	Repair the operating system.	“Repairing the Operating System,” later in this chapter
6	Reinstall the operating system.	“Reinstalling the Operating System,” later in this chapter

Safeguarding Your Data

Software or devices added to the notebook can cause your system to become unstable. To safeguard your documents, store personal files in the My Documents folder and periodically create a backup copy of My Documents.

Using System Restore

The System Restore utility enables you to safeguard your system files and settings by using restore points, which are restorable, benchmark “snapshots” of your application, driver, and operating system files.

The notebook sets restore points at regular intervals and may set additional restore points when you change your personal settings or add software or hardware.

Manually setting additional restore points provides additional protection for your system files and settings. It is recommended that you manually set restore points

- Before you add or extensively modify software or hardware.
- Periodically, whenever the system is performing optimally.

Restoring to any restore point does not affect your data files. For example, restoring your system software to an earlier time will not affect documents or e-mails that you saved after that time. All System Restore procedures are reversible.

Setting a Restore Point

To set a system restore point manually:

1. Select **Start > Help and Support > System Restore**.
2. Select **Create a restore point**, and then follow the instructions on the screen.

Restoring to a Restore Point

To restore the notebook to a restore point:

1. Make sure the notebook is connected to reliable external power through the AC adapter.
2. Select **Start > Help and Support > System Restore**.
3. Select **Restore my computer to an earlier time**, and then follow the instructions on the screen.

Repairing or Reinstalling Drivers

All drivers required for notebook functionality can be reinstalled from the *Driver Recovery* disc included with your notebook.

If you have not reinstalled your operating system, these drivers can also be reinstalled from your hard drive.

The driver reinstallation process repairs or replaces most corrupted drivers and reinstalls most deleted drivers.

Some factory-installed drivers for external devices may not be available for reinstallation from either the *Driver Recovery* disc or your hard drive. You can usually obtain drivers for an external device from a disc included with the device or from the Web site of the device manufacturer or provider.

Repair or reinstall the drivers for notebook functionality before repairing or reinstalling drivers for external devices.

- *To reinstall the drivers required for notebook functionality from your hard drive*—**Select Start > All Programs > Software Setup**, and then follow the instructions on the screen. (When you are prompted to select the drivers you want to reinstall, you can select or clear the check boxes for some or all of the listed drivers.)
- *To reinstall the drivers required for notebook functionality from the Driver Recovery disc*—While running Windows, insert the *Driver Recovery* disc into the optical drive, and then follow the instructions on the screen. (When you are prompted to select the drivers you want to reinstall, you can select or clear the check boxes for some or all of the listed drivers.)

If the disc does not open within several seconds:

- a. Select **Start > Run**.
- b. In the **Open** text field, type `D:\SWSETUP\APPINSTL\SETUP.EXE` where D indicates the optical drive.
- c. Select **OK**.

Repairing or Reinstalling Applications

All applications preinstalled or preloaded on your notebook can be repaired or reinstalled by using a recovery disc.

If you have not reinstalled your operating system, some applications preloaded on your notebook, such as those available in the Software Setup utility, can also be repaired or reinstalled from your hard drive.

The application reinstallation process repairs or replaces corrupted system files within the application and reinstalls deleted system files within the application.

- In most cases: If the application you are repairing or reinstalling is still installed on your notebook, the reinstallation process does not affect your settings within the application.
- In all cases: If an application has been deleted from your notebook, the reinstallation process reinstalls the application with factory settings.

Reinstalling Applications from Your Hard Drive

To reinstall a preloaded application or utility from your hard drive:

- » Select **Start > All Programs > Software Setup**, and then follow the instructions on the screen.

(When you are prompted to select the software you want to reinstall, you can select or clear the check boxes for some or all of the listed items.)

Reinstalling Applications from a Recovery Disc

The location of application recovery software varies by notebook model.

- Some or all of your application recovery software may be on the *Driver Recovery* disc.
- Some or all of your application recovery software may be on one or more *Application Recovery* discs.

Use the following procedure to restore or reinstall the applications on either the *Driver Recovery* disc or an *Application Recovery* disc. It is recommended that you restore applications first from the *Driver Recovery* disc and then from any *Application Recovery* discs included with your notebook.

To reinstall a preloaded or preinstalled application from the *Driver Recovery* disc or an *Application Recovery* disc:

- » While the notebook is in Windows, insert the disc into the optical drive, and then follow the instructions on the screen. (When you are prompted to select the applications you want to reinstall, you can select or clear the check boxes for some or all of the listed items.)

If the disc does not open within several seconds:

- a. Select **Start > Run**.
- b. In the **Open** text field, type `D:\SWSETUP\APPINSTL\SETUP.EXE` where D indicates the optical drive.
- c. Select **OK**.

Repairing the Operating System

To repair the operating system without deleting your personal data:

1. Be sure the notebook is connected to a AC outlet through the AC adapter.
2. Insert the *Operating System* disc (included with the notebook) into the optical drive.
3. Shut down the notebook using the standard shutdown procedure for your operating system:
 - ❑ In Windows XP Home, press **ctrl+alt+del**, and then select **Shut Down > Turn Off**.
 - ❑ In Windows XP Professional, press **ctrl+alt+del**. Select **Shut down** from the drop-down list, and then select **OK**.



If you are unable to shut down the notebook using the **ctrl+alt+del** keys, press and hold the power button for 4 seconds.

4. Turn on the notebook by briefly pressing the power button.
5. When prompted, press any key to boot from disc. (After a few minutes, the setup wizard opens and the “Welcome to Setup” page is displayed).



On the “Welcome to Setup” page do *not* press **R** (step 8 in this procedure) until you have completed steps 6 and 7.

6. Press **enter** to continue. (The “Licensing Agreement” page is displayed).
7. Press **f8** to accept the agreement and continue. (The “Setup” page is displayed).
8. Press **R** to repair the selected Windows installation. (The repair process begins).

After the repair process is complete, which may take up to several hours, the notebook restarts in Windows.

Reinstalling the Operating System

If you could not solve the problem by repairing the operating system as described in the previous section, it may be necessary to reinstall the operating system.

Reinstalling the operating system deletes all files on the notebook.

- Before you begin the reinstallation, it is recommended that you back up your data.
- After you complete the reinstallation
 - You must reinstall all drivers required for notebook functionality.
 - To fully restore your system, you will also need to
 - ◆ Reinstall all of your additional software.
 - ◆ Update all of your reinstalled software, including the operating system.

Back Up Data



CAUTION: To prevent the loss of all of your personal data, back up your data before reinstalling the operating system. Reinstalling the operating system deletes all personal data, settings, and software on your notebook.

To back up your data you can do any of the following:

- Purchase optional system backup software.
- Copy individual data files to storage devices other than your hard drive.
- Use the system backup utility available in Windows XP Professional:

Select **Start > All Programs > Accessories > System Tools > Backup.**

If you plan to select the items you want to back up, rather than backing up your entire system, the following suggestions may be helpful:

- On many notebooks, data files are stored by default in the My Documents folder. If you created data files in other locations, be sure to check all the possible locations.
- Templates are often stored in the folders of their associated applications. For example, a Microsoft Word template that you created may be stored at C:\Program Files\Microsoft Office\Templates.
- The shortcuts on a desktop are often stored in C:\Documents and Settings\ (Your User Account)\ Desktop.
- If you have customized the settings in a window, toolbar, or menu bar, you may want to take a screen shot of that element. The screen shot could be a time-saving reference when you begin resetting your preferences. A screen shot is a copy of an element on the screen. To copy the element from the screen and paste it into a Word document:
 - a. Display the element on the screen.
 - b. Copy the element or entire screen:
 - ◆ To copy only the active window, press **alt+fn+prt sc**.
 - ◆ To copy the entire screen, press **fn+prt sc**.
 - c. To paste the copied image into a document, open Word, and then select **Edit > Paste**.

Reinstall the Operating System



During the reinstallation, you may be prompted for your Product Key. Your Product Key is provided on the Microsoft Certificate of Authenticity label affixed to the bottom of the notebook.



During the reinstallation, it is normal for some notebook models to pause occasionally for several minutes and to restart several times. These normal pauses are indicated by an hourglass icon.

To reinstall the operating system using the *Operating System* disc included with the notebook:

1. Make sure the notebook is connected to a AC outlet through the AC adapter.
2. Insert the *Operating System* disc into the optical drive.
3. Shut down the notebook using the standard shutdown procedure for your operating system:
 - In Windows XP Home, press **ctrl+alt+del**, and then select **Shut Down > Turn Off**.
 - In Windows XP Professional, press **ctrl+alt+del**. Select **Shut down** from the drop-down list, and then select **OK**.

 If you are unable to shut down the notebook by using the **ctrl+alt+del** keys, press and hold the power button for 4 seconds.
4. Turn on the notebook by briefly pressing the power button.
5. When prompted, press any key to boot from disc. (After a few minutes, the “Welcome to Setup” page is displayed).
6. Press **enter** to continue. (A “Licensing Agreement” page is displayed).

7. Press **f8** to accept the agreement and continue. (The “Setup” page is displayed).
8. Press **esc** to continue installing a fresh copy of the operating system.
9. Press **enter** to set up the operating system.
10. Press **C** to continue setup using this partition.
11. Select **Format the partition using the NTFS file system (Quick)**, and then press **enter**. (A caution is displayed. The caution explains that formatting this drive will delete all current files).
12. Press **F** to format the drive. (The reinstallation process begins).

After the reinstallation process is complete, which may take up to several hours, the notebook restarts in Windows. To properly set up Windows, follow the instructions on the screen.

Reinstall Drivers

After the operating system reinstallation process is complete, you must reinstall the drivers required for notebook functionality and you may need to reinstall the drivers for some external devices. For driver reinstallation instructions, refer to [“Repairing or Reinstalling Drivers,”](#) earlier in this chapter.

Reinstall Additional Software

After you have reinstalled drivers, you can begin to reinstall additional software.

- To reinstall software included with your notebook, follow the instructions in [“Repairing or Reinstalling Applications,”](#) earlier in this chapter.
- To reinstall software that was not included with your notebook, refer to the installation instructions included with the software. Installation instructions are usually provided on the software CD, in the CD package, or at the Web site of the software provider or manufacturer.

Update Reinstalled Software

It is strongly recommended that you update all reinstalled software. Depending on the settings you used on your former configuration, some software may have been automatically updated without your knowledge. Use the following update procedures as soon as your notebook is connected to the Internet.

To access update links for the operating system and other software provided on your notebook:

- » Select **Start > Help and Support**.

To update optional software, follow the instructions included with the software. Many applications include an update feature that you can access from a Help button or menu item within the application.

If you are unable to update your operating system from the Internet and a *Critical Security Updates for Windows XP* disc was included with your notebook, refer to [“Critical Security Updates for Windows XP”](#) in Chapter 12, “Security.”

Notebook Care

Temperature



WARNING: To avoid potential discomfort or burns, do not block the air vents or use the notebook on your lap for extended periods. The notebook is designed to run demanding applications at full power. As a result of increased power consumption, it is normal for the notebook to feel warm or hot when used continuously. The notebook complies with the user-accessible surface temperature limits defined by the International Standard for Safety of Information Technology Equipment (IEC 60950).

Notebook



WARNING: To reduce the risk of electric shock or damage to your equipment:

- Before cleaning your notebook, disconnect the notebook from external power and disconnect all external devices from the notebook.
 - Do not spray liquids on your notebook, display, or keyboard.
 - Do not allow liquids to drip onto the notebook keyboard.
-



CAUTION: To prevent permanent damage to the finish and interior compartments of your notebook, do not allow liquids to come in contact with your notebook, display, or keyboard. Liquids and household solvents can permanently damage the finish and interior components of your notebook.



CAUTION: To prevent possible damage to the display, do not place anything on top of the notebook even when the notebook is in a carrying case.



CAUTION: To prevent overheating, do not obstruct the vents. Do not allow a hard surface, such as an adjoining optional printer, or a soft surface, such as fabric or carpet, to block the airflow. For vent location information, refer to “[Bays and Vents](#)” in [Chapter 1, “Component ID.”](#)”

Your notebook is designed to be durable. To help maintain the performance and appearance of your notebook, the following suggestions may be helpful:

- Carry and store your notebook in an optional portable carrying case.
- Avoid placing heavy objects on top of the notebook, even when the notebook is inside a carrying case.
- Protect your notebook, especially the display and keyboard, from liquids and excessive moisture.
- Avoid exposing your notebook to direct sunlight, extreme temperatures, or ultraviolet light for extended periods of time.
- Use your notebook only on a solid, flat surface. Make sure that vents, which cool internal components, are unobstructed.
- If your notebook will not be used for a week or more, shut it down.
- If your notebook will be disconnected from external power for more than 2 weeks:
 - Shut down the notebook.
 - Remove the battery pack and store it in a cool, dry place.

Keyboard

 **CAUTION:** To prevent permanent damage to your keyboard, do not use liquids of any kind on your keyboard. Any liquid could cause permanent damage to your keyboard and to the internal components of your notebook. Some liquids and household solvents can permanently damage the finish of your notebook.

 **CAUTION:** To prevent the deposit of household debris on the keyboard, do not clean the keyboard with a regular vacuum cleaner.

Clean the keyboard regularly to prevent keys from sticking and to remove dust, lint, and particles that can become trapped beneath the keys.

Ideally, use a can of compressed air with a straw extension to blow air in and around the keys.



Display



CAUTION: To prevent permanent damage to your notebook, do not spray water, cleaning fluids, chemicals, or any other liquid on the screen.

To remove smudges and lint, frequently clean your display with a soft, damp, lint-free cloth. If the screen requires additional cleaning, use an antistatic screen cleaning product or premoistened antistatic wipes.

TouchPad

Grease and dirt on the TouchPad can cause your pointer to move erratically. To protect the performance of your TouchPad:

- Wash your hands frequently while you are using the notebook.
- Clean the TouchPad often with a damp cloth.

External Mouse

Keeping an optional external mouse clean can substantially improve the performance of the mouse and prevent the loss of mouse pointer control.

To clean an external mouse that resembles the mouse in the following illustrations:

1. Turn the mouse upside down.



2. Rotate the circular plate until the plate pops loose ①. Most mice have an arrow to indicate the direction to turn the plate.

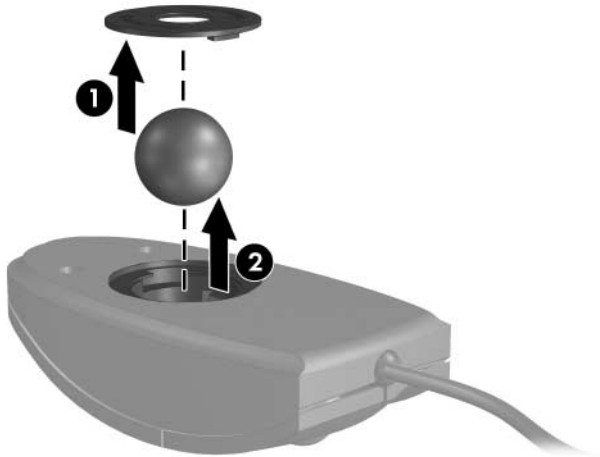

3. Remove the ball ② from your mouse and clean it with an antistatic wipe or a lint-free cotton cloth.

4. To remove loose debris and dust, spray the inside of the mouse with compressed air or clean it with a non cotton swab.



5. Replace the ball and the circular plate.

Travel and Shipping

Travel

When you travel with your notebook, the following suggestions may be helpful:

- Take along a backup of your work. Keep the backup separate from the notebook.
- Do not expose the notebook or diskettes to a magnetic security detector.
 - The security device that examines carry-on items placed on a conveyor belt uses x-rays and is safe for the notebook and diskettes.
 - The walk-through security device and the handheld security wands are magnetic and may damage the notebook or diskettes.
- If you are traveling by air
 - Carry your notebook as hand baggage. Do not check it with the rest of your luggage.
 - Check in advance with the airline if you plan to use the notebook during a flight. In-flight notebook use is at the discretion of the airline.

- If you are traveling internationally:
 - ❑ Consult with Customer Care about power cord and adapter requirements for each location in which you plan to use the notebook. (Voltage, frequency, and plug configurations vary.)
 - ⚠ To reduce the risk of electric shock, fire, or damage to the equipment, do not attempt to run the notebook with a voltage converter kit sold for appliances.
 - ❑ Check the computer-related customs regulations for each country on your itinerary.
 - ❑ Review “[Modem Country Selection](#)” in [Chapter 10](#), “[Modem and Networking](#).”
- Read “[Shipping](#),” next in this chapter. Most procedures for shipping the notebook apply also to traveling with the notebook.

Shipping

To prepare the notebook for shipping or traveling:

1. Back up your work. For backup information, refer to “[Back Up Data](#)” in [Chapter 14](#), “[Software Updates and Recovery](#).”
2. Remove all media, including CDs, DVDs, PC Cards, ExpressCards, digital memory cards, etc.
3. Turn off, then disconnect, all external devices.
4. Shut down the notebook.
5. If the notebook will be disconnected from an external power source for more than 2 weeks, remove the battery pack. Store the battery pack in a cool, dry place.
6. If you are shipping the notebook, place it in the original packing box or similar protective packaging and label the package as “fragile.”

If you think your shipping or travel plans may expose the notebook to extreme environments, review “[Operating Environment](#)” in [Chapter 17](#), “[Specifications](#).”

Specifications

Operating Environment

The operating environment information in the following table may be helpful if you plan to use or transport the notebook in extreme environments.

Factor	Metric	U.S.
Temperature		
Operating	10°C to 35°C	50°F to 95°F
Nonoperating	-20°C to 60°C	-4°F to 140°F
Relative humidity (noncondensing)		
Operating	10% to 90%	10% to 90%
Nonoperating	5% to 95%	5% to 95%
Maximum altitude (unpressurized)		
Operating	-15 m to 3,048 m	-50 ft to 10,000 ft
Nonoperating	-15 m to 12,192 m	-50 ft to 40,000 ft

Rated Input Power

The power information in this section may be helpful if you plan to travel internationally with the notebook.

The notebook operates on DC power, which can be supplied by an AC or a DC power source. Although the notebook can be powered from a stand-alone DC power source, it is strongly recommended that the notebook be powered only with an AC adapter or DC power cord supplied with or approved for an HP notebook.

The notebook is capable of accepting DC power within the following specifications.

Input Power	Rating
Operating voltage	18.5 V dc to 19.0 V dc
Operating current	4.9 A or 6.5 A

This product is designed for IT power systems in Norway with phase-to-phase voltage not exceeding 230V.

Expansion Port 2 Input/Output Signals

The signal information in this section may be helpful if you plan to use an optional expansion product that connects to the expansion port 2 on your notebook. (The notebook has only one expansion port. The term *expansion port 2* describes the type of expansion port.)

The expansion port 2 is illustrated in “[Right-Side Components](#)” in [Chapter 1, “Component ID.”](#)

The following table identifies the input and output signals supported by the expansion port 2 on your notebook.

Feature	Support
USB 2.0	Yes
10/100 Ethernet	Yes
Gigabit Ethernet	No
IEEE 1394 (4-pin port)	Yes
Consumer IR (for optional remote control only)	Yes
Power inputs	90-W to 240-W maximum
Composite TV*	Yes
S-Video TV	Yes
Component TV	No
S/PDIF audio*	Yes
DVI	No
Headphone/speaker audio-out	Yes
Microphone audio-in	Yes
*Requires the use of an optional expansion product.	

Index

1394 port 1–10, 9–3

A

AC adapter 1–17

AC power vs. battery power
2–4

adapters

2-pin (for power cord) 2–3

AC 1–17

country-specific modem
10–1

airport security devices 5–1,
16–1

altitude specifications 17–1

analog vs. digital line 10–1,
10–7

antennae 1–16

antivirus software 12–1,
12–19

Application Recovery disc
1–18

applications

default multimedia 3–12,
4–10

installing 4–12

reinstalling or repairing
14–12

See also software

applications key, Windows
1–7

AT commands, modem 10–9

audio cable 4–7

audio-in (microphone) jack
4–1

audio-out (headphone) jack
4–2, 4–7

AutoPlay 4–17, 5–6

B

backup 14–9, 14–15

base, docking. *See* docking
device

- battery bay
 - identifying 1–14
 - inserting, removing battery pack 2–17
 - labels inside 1–19
 - battery light
 - displaying charge status 2–19, 2–21
 - identifying 1–2, 2–1
 - battery pack
 - battery power vs. AC power 2–4
 - calibrating 2–24
 - charging 2–19
 - conserving power 2–28
 - diagnostic information 13–4
 - disposing of 2–30
 - inserting 2–17
 - low-battery conditions 2–21
 - monitoring charge 2–20
 - removing 2–18
 - storing 2–29
 - battery pack release latch 1–14, 2–18
 - battery power vs. AC power 2–4
 - bays
 - battery 1–14, 1–19
 - hard drive 1–14
 - See also* compartment, expansion memory module
 - BIOS information, displaying
 - fn+esc** 3–11
 - password protection 12–2
 - Service Tag 14–2
 - Setup utility 13–4
 - Bluetooth device
 - functions 11–9
 - wireless button 1–6, 11–2
 - wireless light 1–6, 11–2
 - Bluetooth label 1–19
 - boot order 13–6
 - buttons
 - DVD 3–12, 3–14
 - Internet 3–12
 - music 3–12, 3–14
 - mute 1–8, 4–3
 - PC Card eject 1–12, 6–4
 - power 1–4, 2–9, 2–13
 - TouchPad 1–3, 3–2
 - volume 1–8, 4–3
 - wireless 1–6, 11–2
 - See also* display switch; keys; latches
- C**
- cable lock, security 1–13, 12–22
 - cables
 - audio 4–7
 - modem 1–17, 10–1
 - network 1–11, 10–10
 - S-Video 4–4, 4–7
 - See also* power cord
 - calibration, battery 2–24

- camcorder
 - connecting 9–3
 - digital memory cards 7–1
 - camera
 - connecting 9–3
 - digital memory cards 7–1
 - caps lock light 1–1
 - card and socket services
 - ExpressCard 6–6
 - PC Card 6–1
 - cards. *See* digital memory cards; ExpressCards; memory modules; PC Cards; xD-Picture Cards
 - care and maintenance 15–1
 - category view, Windows 2–7
 - Certificate of Authenticity label 1–19, 14–17
 - classic view, Windows 2–7
 - color television format 4–8
 - compartment, expansion
 - memory module 1–15, 8–2
 - composite video 3–7, 17–3
 - computer viruses 12–19
 - connectors
 - digital memory card 7–3
 - drive 5–1
 - ExpressCard 6–6
 - PC Card 6–2
 - power 1–9
 - See also* jacks; ports
 - conservation, power 2–28
 - consumer infrared lens 1–8
 - cord, power
 - connecting 2–3
 - identifying 1–17
 - See also* cables
 - country-specific modem
 - adapter 1–17, 10–1, 10–4
 - critical low-battery condition 2–22
 - Critical Security Updates for Windows XP* disc 12–20
- D**
- default settings
 - multimedia applications 4–10
 - restoring Setup utility 13–5
 - desktop, Windows, setting icon display preferences 3–16
 - dialing modes 10–7
 - Digital Media Slot 1–12, 7–1
 - Digital Media Slot light 1–12, 7–2
 - digital memory cards
 - Digital Media Slot 7–1
 - disabling 12–18
 - inserting 7–3
 - removing 7–4
 - setting AutoPlay preferences 4–18
 - types supported 7–1
 - digital vs. analog line 10–1, 10–7

- discs
 - Application Recovery*
 - 14–13
 - changing regional DVD settings 4–18
 - containing multimedia applications 4–9
 - copying 4–15
 - copyright warning 4–14
 - creating 4–15
 - Critical Security Updates for Windows XP* 12–20
 - disabling 12–18
 - displaying contents 4–17, 5–6
 - Driver Recovery* 14–11, 14–13
 - inserting 5–3
 - installing applications from 4–12
 - media activity hotkeys 4–16
 - Operating System Recovery* 14–17
 - playing 4–9, 4–16, 4–17
 - removing 5–4
 - setting AutoPlay preferences 4–17
 - writing to 4–15
- diskette
 - affected by airport security 5–1, 16–1
 - protecting playback 2–9, 5–6
- display release latch 1–8
- display switch
 - identifying 1–4
 - setting preferences 2–2, 2–13
- display, internal
 - care and maintenance 15–4
 - controlling brightness 3–10
 - switching image 3–7
- docking device
 - docking, undocking while using disc, diskette 4–17
 - expansion port 2 on notebook 1–10
 - USB support 9–1
- DriveLock 12–13
- DriveLock password. *See* passwords
- Driver Recovery* disc 1–18, 14–17
- drivers
 - obtaining 14–11
 - reinstalling, repairing 1–18, 14–18
- drives
 - affected by airport security 5–1
 - avoiding standby and hibernation while using discs, diskettes 2–9, 4–17
 - boot order 13–6
 - disabling 12–18
 - IDE drive light 5–2
 - shipping 5–1
 - USB 9–1
 - See also* discs; hard drive; optical drives
- DVD button 3–12, 3–14

E

- eject button, PC Card 6–4
- electrostatic discharge (ESD)
 - 8–2
- emergency shutdown
 - procedures 2–13
- enablers
 - ExpressCard 6–6
 - PC Card 6–1
- End-User License Agreement, operating system 14–14
- environmental specifications 17–1
- error messages
 - DVD 4–19
 - memory module 8–2
 - No Dial Tone 10–8
- ESD (electrostatic discharge) 8–2
- exhaust vent 1–9, 1–11, 1–14
- expansion memory module slot 8–1
 - See also* memory; memory modules
- expansion port 2 1–10, 17–3
- ExpressCard slot 1–12, 6–6
- ExpressCards
 - configuring 6–6
 - inserting 6–7
 - removing 6–8
 - removing insert in
 - ExpressCard slot 6–6
 - stopping 6–8
 - types supported 6–5

- external device drivers 14–11
- external monitor port 1–9, 4–6
- external numeric keypad 3–20

F

- F12 to boot from LAN
 - message 13–6
- firewall software 12–1, 12–21
- flash memory cards 7–1
- fn** key 1–7
- function keys (**f1**, **f2**, etc.) 3–4, 13–6

G

- Getting Started* 1–18

H

- hard drive
 - affected by airport security 5–1
 - displaying amount of free space on 8–7
 - DriveLock 12–13
 - replacing (primary) 5–2
 - self-test 13–6
 - space on, required for hibernation file 8–7
 - See also* drives
- hard drive bay
 - identifying 1–14
 - replacing hard drive 5–2
- headphone (audio-out) jack 1–11, 4–2, 4–7
- headphones 4–2
- Help and Support Center 3–5

- hibernation
 - avoiding when using discs, diskettes 2-9, 4-17, 5-6
 - defined 2-6
 - enabling/disabling 2-7
 - file space requirements for 8-7
 - initiated during critical low-battery condition 2-22
 - initiating 2-6, 2-11
 - restoring from 2-6, 2-11
 - setting preferences 2-13
 - when to use 2-8
 - hibernation file 2-6, 8-7
 - hotkey commands
 - access Help and Support Center 3-5
 - control media activity (play, pause, stop, etc.) 3-10
 - decrease display brightness 3-10
 - display system information 3-11, 14-2
 - increase display brightness 3-10
 - initiate QuickLock 3-8, 12-3
 - initiate standby 2-12, 2-13
 - open Internet Explorer 3-6
 - open print options window 3-6
 - Quick Reference 3-4
 - switch image 3-7
 - hotkeys
 - displaying functions on the screen 3-15
 - identifying 1-7, 3-4
 - procedures 3-5
 - Quick Reference 3-4
 - using with external keyboard 3-11
 - HP administrator password.
See passwords
 - hub, USB 9-1
 - humidity specifications 17-1
- I**
- icons
 - hotkey 3-4
 - multimedia 4-9
 - on function keys 3-4
 - Power Meter 2-4, 2-14
 - Quick Launch Buttons 3-13
 - Safely Remove Hardware 6-4, 6-8
 - IDE drive light 1-2, 5-2
 - identifying components
 - additional included hardware 1-17
 - bottom 1-14, 1-19
 - front 1-8
 - left-side 1-12
 - rear 1-9
 - right-side 1-10
 - top 1-1, 1-19
 - IEC 60950 compliance 15-1
 - IEEE 1394 port 1-10, 9-3
 - infrared lens 1-8

Internet button 3–12
Internet Connection Wizard
 3–6, 3–12
Internet Explorer 3–6, 3–12
InterVideo WinDVD Creator
 4–11
InterVideo WinDVD Player
 4–11, 4–20
IR lens 1–8
iTunes, Apple 4–11

J

jacks

- audio-in (microphone)
 1–11, 4–1
- audio-out (headphone)
 1–11, 4–2, 4–7
- PBX 10–1
- RJ-11 (modem) 1–9, 10–1
- RJ-45 (network) 1–11,
 10–10
- S-Video-out 1–11, 4–4,
 4–7

See also connectors; ports

K

keyboard revision number,
 displaying 3–11
keyboard, external 3–11
keyboard, internal, care and
 maintenance 15–1
keypad, embedded numeric
 identifying 1–7, 3–18
 procedures 3–19

keys

- fn** 1–7, 3–4
- function (**f1**, **f2**, etc.) 1–7,
 3–4
- hotkeys 3–4
- keypad 1–7, 3–18
- num lock** 3–19
- prt sc** 14–16
- scroll lock** 3–11
- shift** 2–11, 3–20
- Windows applications 1–7
- Windows logo 1–7

See also buttons; display
 switch; latches

L

labels

- Bluetooth 1–19
- Microsoft Certificate of
 Authenticity 1–19, 14–17
- Modem Approval 1–19
- Regulatory 1–19
- Service Tag 1–19, 14–2
- wireless certification 1–19

language, changing in Setup
 utility 13–3

latches

- battery pack release 1–14,
 2–18
- display release 1–8

See also buttons; display
 switch

lens, infrared 1–8

- lights
 - battery 1-2, 2-19, 2-21
 - caps lock 1-1
 - Digital Media Slot 1-12
 - IDE drive 1-2, 5-2
 - mute 1-8, 4-3
 - num lock 1-1, 3-19
 - power/standby 1-2, 2-9
 - TouchPad 1-3, 3-2
 - wireless 1-6, 11-2
- location settings, modem 10-5
- lock, security cable 1-13, 12-22
- lock-up, system 2-13
- low-battery condition 2-22

M

- Media Player, Windows 4-10
- media, digital 7-1
- memory
 - displaying amount of 3-5, 8-7
 - increasing RAM 8-1, 8-7
- memory module compartment, expansion 1-15, 8-3
- memory module slot
 - expansion 8-1
 - primary 8-1
- memory modules
 - defined 8-1
 - removing or inserting 8-2
 - selecting 8-2
- Memory Stick, Memory Stick Pro 1-12, 7-1
- microphone 4-1
- microphone (audio-in) jack 1-11, 4-1
- Microsoft Certificate of Authenticity label 1-19, 14-17
- model, identifying notebook 3-5, 14-2
- modem
 - AT commands 10-9
 - cable 10-1
 - country-specific adapter 1-17, 10-1, 10-4
 - dialing mode (pulse or tone) settings 10-7
 - jack 10-1, 10-3
 - location settings 10-5
 - travel connection
 - troubleshooting 10-7
 - virus protection 12-19
- modem (RJ-11) jack 1-9, 10-3
- Modem Approval label 1-19
- modem cable 1-17, 10-1
- modules, memory 8-1
- monitor port, external 1-9, 4-6
- monitor, external
 - connecting 4-6
 - switching image 3-7, 4-6

mouse, external
 care and maintenance 15–4
 setting preferences 3–3
 USB 9–1
MultiMediaCard 1–12, 7–1
music button 3–12, 3–14
mute button 1–8, 4–3
mute light 1–8, 4–3

N

network
 connecting 10–11
 Network Service Boot
 13–6
 PreBoot eXecution
 Environment (PXE)
 server 13–6
network (RJ-45) jack 1–11,
 10–10
network cable 1–11, 10–10
Network Service Boot 13–6
No Dial Tone message 10–8
noise suppression circuitry
 10–2
Norton AntiVirus 12–1, 12–19
notebook model, family, type,
 and serial number 3–5, 14–2
num lock key 3–19
num lock light 1–1, 3–19

O

operating environment
 specifications 17–1

operating system
 firewall 12–1, 12–21
 Internet Connection
 Wizard 3–6, 3–12
 loading 2–10
 Microsoft Certificate of
 Authenticity label 1–19,
 14–17
 modem settings 10–5, 10–7
 passwords 12–5
 Product Key 1–19, 14–17
 reinstalling 14–9, 14–15
 repairing 14–9, 14–14
 shutting down 2–10, 2–13
 updating 12–20
optical disc. *See* discs
optical drives
 AutoPlay 5–6
 avoiding standby and
 hibernation while using
 disc 5–6
 inserting disc 5–3
 removing disc 5–4
 types available for your
 notebook model 1–13
 types required for creating
 CDs, DVDs 4–9
 See also discs; drives
overheating, precautions 15–1

P

passwords

- coordinating 12–5
- DriveLock 12–6, 12–13
- forgetting 12–5
- HP administrator 12–9
- power-on 12–11
- QuickLock 3–8, 12–3
- recording 12–5
- standby 2–16
- Windows administrator
 - 3–8, 12–3, 12–5
- Windows user 3–8, 12–3, 12–5

PBX jacks 10–1

PC Card eject button 1–12, 6–4

PC Card slot 1–12, 6–2, 6–6

PC Cards

- configuring 6–1
- inserting, removing 6–2
- removing insert in PC Card slot 6–2
- stopping 6–4
- types supported 6–1

PCFriendly 4–14

pointing device 3–1

ports

- 1394 1–10, 9–3
 - expansion port 2 1–10, 17–3
 - external monitor 1–9, 3–7, 4–6
 - USB 1–9, 1–10, 1–13, 9–1
- See also* connectors; jacks

power

- conserving 2–5, 2–28
 - control and light locations
 - 2–1
 - schemes 2–15
 - setting preferences 2–13
 - sources 2–4
 - switching between AC and battery 2–4
- See also* battery pack; hibernation; shutdown procedures; standby

power button

- default functions 2–9
- identifying 1–4, 2–2
- resetting notebook with 2–13
- setting preferences 2–13

power connector 1–9

power cord

- external device 4–6
 - notebook 1–17
- See also* cables

Power Meter 2–21

Power Meter icon 2–4, 2–14

power, AC vs battery 14–8

power/standby lights 1–2, 2–9

power-on password. *See* passwords

PreBoot eXecution

- Environment (PXE) server 13–6

preloaded software

- accessing, displaying, installing 4–12
- reinstalling 14–19

- Press ESC to change boot order message 13–6
- primary hard drive. *See* drives; hard drive
- primary memory module slot
 - See also* memory; memory modules
- primary memory modules slot 8–1
- processor name, displaying 3–11
- Product Key 1–19, 14–17
- product name and number, notebook 1–19, 3–11
- projector
 - connecting 1–9
 - switching image 3–7
- pulse dialing mode 10–7
- Q**
- Quick Launch Buttons
 - control panel 3–13
 - icon 3–13
 - identifying 3–12
 - setting preferences 3–14
- QuickLock 3–8, 12–3
- R**
- RAM (random access memory) 8–1, 8–7
- reader, memory card 7–1
- recovery discs, procedures.
 - See* system recovery
- regional settings for DVDs 4–18
- regulatory information
 - Modem Approval label 1–19
 - Regulatory label 1–19
 - wireless certification labels 1–19
- reinstallation, software. *See* system recovery
- release latch, battery pack 1–14, 2–18
- remote control
 - buttons 3–14
 - infrared lens 1–8
- repair, software. *See* system recovery
- reset (emergency shutdown procedures) 2–13
- restore point 14–10
- RJ-11 (modem) jack 1–9, 10–1, 10–3
- RJ-45 (network) jack 1–11, 10–10
- ROM
 - determining current version of 14–2
 - downloading and installing 14–4
 - obtaining updates 14–4
- ROMPaq 14–4
- S**
- scanner 9–3
- screen saver 2–29, 12–6
- scroll lock** key 3–11
- scroll zone, TouchPad 1–3, 3–2

- Secure Digital (SD) Memory Card 1–12, 7–1
- security cable slot 1–13
- security cable, connecting 12–22
- security features, summary 12–1
- serial number, notebook 1–19, 3–5
- Service Tag 1–19, 14–2
- Setup utility
 - changing language 13–3
 - displaying system information 13–4
 - navigation and selection 13–4
 - Network Service Boot 13–6
 - opening 13–2
 - restoring default settings 13–5
 - setting security preferences 12–2
 - video memory settings 8–7
- shift** key
 - embedded numeric keypad function 3–20
 - hibernation function 2–11
- shipping
 - drive 5–1
 - notebook 16–2
- shutdown procedures 2–10
- sleep. *See* standby
- slots
 - Digital Media Slot 1–12, 7–1
 - ExpressCard 1–12, 6–5
 - memory module 1–15, 8–1
 - PC Card 1–12, 6–1
 - security cable 1–13, 12–22
- SmartMedia (SM) card 1–12, 7–1
- socket services
 - ExpressCard 6–6
 - PC Card 6–1
- SoftPaq 14–4, 14–7
- software
 - AutoPlay 4–17
 - backing up 14–9, 14–15
 - firewall 12–1, 12–21
 - Internet Connection Wizard 3–6
 - iTunes 4–11
 - multimedia applications 4–9, 4–18
 - Norton AntiVirus 12–1, 12–19
 - Power Meter 2–21
 - Quick Launch Buttons control panel 3–13
 - repairing, reinstalling 1–18
 - ROMPaq 14–4
 - Setup utility 13–1
 - SoftPaq 14–4, 14–7
 - System Restore 14–10
 - updating 12–20, 14–1
 - WLAN 11–8

- Software Setup folder
 - installing multimedia applications 4–9, 4–12
 - reinstalling applications 14–12
 - reinstalling drivers 14–11
- software, recovery 14–9
- Sonic RecordNow! 4–11, 4–20
- speakers
 - external 4–2
 - internal 1–5, 4–2
- specifications
 - expansion port 2 signals 17–3
 - operating environment 17–1
 - rated input power 17–2
- standby
 - avoiding when using discs, diskettes 2–9, 4–17, 5–6
 - initiated during critical low-battery condition 2–22
 - initiating 2–12
 - password 2–16
 - power/standby lights 1–2
 - resuming from 2–12
 - setting preferences 2–13
- stereo speakers
 - external 4–2
 - internal 1–5, 4–2
- S-Video cable 4–4, 4–7
- S-Video-out jack 1–11, 4–4, 4–7
- switch, display
 - identifying 1–4, 2–2
 - setting preferences 2–13
- system information, displaying
 - fn+esc** 3–11
 - Service Tag 14–2
 - Setup utility 13–4
- system lock-up
 - emergency shutdown procedures 2–13
- system recovery
 - backing up data 14–9, 14–15
 - recovery procedures summary 14–9
 - reinstalling operating system 14–15
 - reinstalling, repairing applications 14–12
 - reinstalling, repairing drivers 14–11
 - repairing operating system 14–14
 - System Restore 14–10
 - updating reinstalled software 14–19
- System Restore 14–10
- T**
- telephone jack (RJ-11 jack) 1–9, 10–1
- television
 - changing color format 4–8
 - connecting audio 4–2
 - connecting video 4–5

- temperature
 - precautions 15–1
 - specifications 17–1
 - storage, battery pack 2–29
- 1394 port 1–10, 9–3
- tone dialing mode 10–7
- TouchPad
 - care and maintenance 15–4
 - identifying 1–3
 - setting preferences 3–3
 - using 3–1
- TouchPad light 1–3, 3–2
- traveling with notebook
 - battery pack temperature considerations 2–29
 - color television format settings 4–8
 - environmental specifications 17–1
- Modem Approval label 1–19
- modem connection
 - troubleshooting 10–7
- modem settings 10–5
- precautions, preparations 16–1
- using modem cable adapter 10–4
- wireless certification labels 1–19
- troubleshooting, modem connections 10–7

- turning off notebook 2–10, 2–13
- turning on notebook 2–10
- tutorials 3–5, 4–14

U

- unresponsive system,
 - emergency shutdown procedures 2–13
- USB devices, connecting 9–1
- USB ports, identifying 1–9, 1–10, 1–13
- user password, Windows. *See* passwords

V

- VCR
 - connecting audio 4–2
 - connecting video 4–7
- vents, exhaust 1–9, 1–11, 1–14
- video device
 - connecting 4–4, 4–7
 - turning on or off 4–8
- video memory settings 8–1, 8–7
- viruses, computer 12–1, 12–19
- volume buttons 1–8
- volume, adjusting 4–3

W

- Windows administrator password. *See* passwords
- Windows applications key 1–7

- Windows category vs.
 - Windows classic view 2–7
 - Windows desktop icons 3–16
 - Windows firewall 12–21
 - Windows logo key 1–7
 - Windows Media Player 4–10
 - Windows MovieMaker 4–10
 - Windows user password. *See* passwords
 - WinDVD Creator 4–11
 - WinDVD Player 4–11, 4–20
 - wireless antennae 1–16
 - wireless button 1–6, 11–11
 - wireless certification label 1–19
 - wireless LAN devices
 - certification labels 1–19
 - identifying 11–6
 - troubleshooting 11–5, 11–8
 - types 11–7
 - types of WLAN adapters 11–7
 - wireless button 1–6
 - wireless light 1–6
 - wireless local area network (WLAN) 11–6
 - WLAN software 11–8
 - wireless light 1–6
- X**
- xD-Picture Cards 1–12, 7–1