

HP Photosmart R927

Digital Camera



User Guide



Legal and notice information

© Copyright 2006 Hewlett-Packard
Development Company, L.P.

The information contained herein is subject to change without notice. The only warranties for HP products and services are set forth in the express warranty statements accompanying such products and services. Nothing herein should be construed as constituting an additional warranty. HP shall not be liable for technical or editorial errors or omissions contained herein.

Windows® is a U.S. registered
trademark of Microsoft Corporation.



SD Logo is a trademark of its
proprietor.

Contents

1	Getting started	5
	Camera top and back	5
	Camera front and bottom.....	6
	Camera dock and insert.....	6
	Before taking pictures.....	7
	Install the battery.....	7
	Charge the battery.....	7
	Turn on the camera.....	7
	Choose the language.....	8
	Set the region.....	8
	Set the date and time.....	8
	Install and format an optional memory card.....	8
	Install the software.....	9
	Using your camera.....	10
2	Taking pictures and recording video clips	11
	Taking still pictures.....	11
	Recording video clips.....	12
	Instant Review.....	12
	Auto focus and exposure.....	12
	Focusing on the subject.....	12
	Optimizing focus.....	13
	Using Focus Lock.....	13
	Optimizing exposure.....	14
	Other recommendations.....	14
	Using the focus range settings.....	14
	Using Manual Focus.....	15
	Using zoom.....	15
	Optical zoom.....	15
	Digital zoom.....	16
	Setting the flash.....	16
	Red eye.....	17
	Using the shooting modes.....	17
	Using Panorama mode.....	18
	Using Manual shooting mode.....	19
	Using My Mode.....	19
	Using the Capture Menu.....	20
	Using the Self-Timer settings.....	23
	Using the Burst setting.....	24
	Exposure Compensation.....	24
	Adaptive Lighting.....	24
	White Balance.....	25
	ISO speed.....	25
3	Reviewing images and video clips	26
	Using Playback.....	26
	Saving frames from video clips.....	27









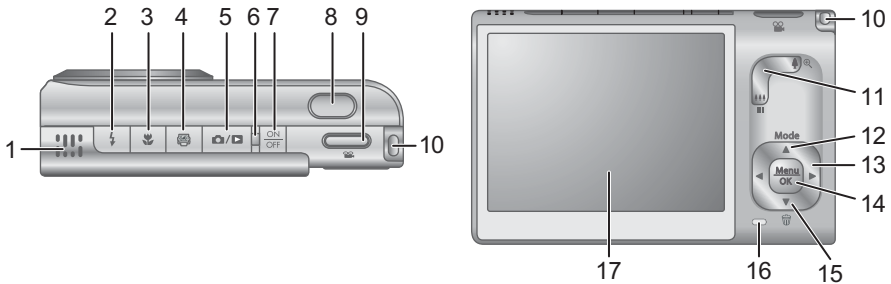



	Viewing thumbnails.....	27
	Magnifying images.....	27
	Using the Playback Menu.....	27
	Deleting images.....	28
	Viewing image information.....	28
	Viewing slideshows.....	29
	Stitching panoramas.....	29
	Recording audio.....	30
4	Using the Design Gallery Menu.....	31
	Applying artistic effects.....	31
	Modifying colors.....	32
	Adding borders.....	32
	Removing red eyes.....	33
	Cropping images.....	33
5	Transferring and printing images.....	35
	Transferring images with HP Photosmart Software.....	35
	Transferring images without HP Photosmart Software.....	35
	Connecting to the computer.....	36
	Using a memory card reader.....	36
	Printing images from the camera.....	36
	Printing panoramas from the camera.....	37
6	Using HP Photosmart Express.....	38
	Using the Photosmart Express Menu.....	38
	Setting up online destinations in the camera.....	38
	Sending individual images to online destinations.....	39
	Selecting individual images for printing.....	39
	Sending all images to a printer or online destinations.....	40
	Buying prints online.....	40
7	Using the Setup Menu.....	41
8	Troubleshooting.....	43
	Resetting the camera.....	43
	Problems and solutions.....	43
9	Product support.....	48
	Helpful websites.....	48
	Getting assistance.....	48
A	Managing batteries.....	50
	Top points about batteries.....	50
	Extending battery life.....	50
	Safety precautions for using batteries.....	50
	Power indicators.....	51
	Number of shots per battery type.....	51
	Recharging the Lithium Ion battery.....	52
	Safety precautions for recharging batteries.....	52
B	Specifications.....	54
	Memory capacity.....	56
	Image quality.....	56
	Video quality.....	56
	Index.....	57

1 Getting started

Use this section to get familiar with the camera controls, set up your digital camera for use, and begin taking pictures.

Camera top and back



1	Speaker.
2	 Flash button—See Setting the flash on page 16 .
3	 Focus button—See Using the focus range settings on page 14 .
4	 Photosmart Express button—See Using HP Photosmart Express on page 38 .
5	 Live View/Playback button.—Switches between Live View and Playback (see Taking pictures and recording video clips on page 11 and Reviewing images and video clips on page 26).
6	Power light.
7	ON/OFF button.
8	Shutter button.
9	 Video button.
10	Wrist strap mount.
11	Zoom lever—See Using zoom on page 15 .
12	Mode button—Press  to access the Shooting Mode menu while in Live View (see Using the shooting modes on page 17).
13	  and   buttons—Scrolls through menus and images.
14	 Menu/OK button—Displays camera menus, selects options, and confirms actions.
15	 Delete button—Press  to access the Delete function while in Playback .

(continued)

16	Battery Charging light.
17	Image Display.

Camera front and bottom

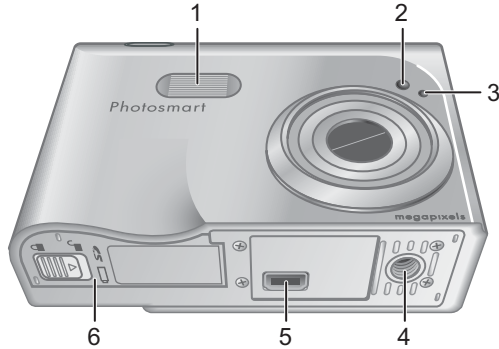

1	Flash.
2	Self-Timer/Focus Assist light—See <i>Using the Self-Timer settings</i> on page 23.
3	Microphone.
4	Tripod mount.
5	Dock connector.
6	Battery/Memory card door.

Camera dock and insert

When setting up the dock for use with this camera, install the dock insert that shipped in the camera box. Attach the dock insert to the top of the camera dock by snapping it into place.

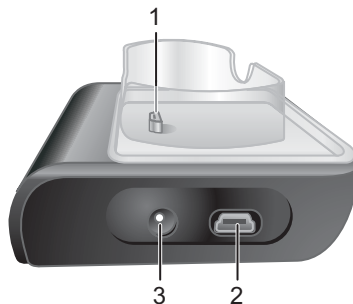

1	Camera/dock connector.
2	USB connector.
3	Power adapter connector.

Before taking pictures

Complete the following procedures before taking pictures or recording video clips.

Install the battery

1. Open the Battery/Memory card door by sliding the door latch as indicated on the Battery/Memory card door.
2. Insert the battery in the larger slot, pushing the battery in until the latch catches.
3. Close the Battery/Memory card door.



Note Turn the camera off before removing the battery. Fully charge the battery before using it the first time (see [Charge the battery](#) on page 7).

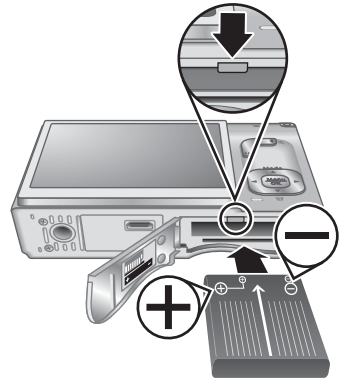

Charge the battery

You can charge a battery in the camera using an optional AC power adapter or in the extra battery bay of an optional HP Photosmart camera dock.

1. Connect the AC power adapter to the dock, then plug it into an electrical outlet.
2. Put the camera in the dock. The camera's blinking Battery Charging light indicates that the battery is charging (if you are charging in an optional HP Photosmart Premium dock, the dock's Battery Charging light blinks). The battery is fully charged when the Battery Charging light turns on solid (approximately 2–3 hours).



Note You can also charge the battery using an optional HP Photosmart quick recharger.



Turn on the camera

To turn on the camera, press the ON/OFF button.

Choose the language

Use $\blacktriangle\blacktriangledown$ $\blacktriangleleft\blacktriangleright$ to choose the language you want, then press $\frac{\text{Menu}}{\text{OK}}$.

To change the language later, use the **Setup** menu (see *Using the Setup Menu on page 41*).



Set the region

Along with the **Language** setting, the **Region** setting determines the default date format and the format of the video signal for displaying camera images on a television when connected through an optional HP Photosmart Premium dock or wireless dock base (see *Using the Setup Menu on page 41*).

Use $\blacktriangle\blacktriangledown$ to choose the region you want, then press $\frac{\text{Menu}}{\text{OK}}$.



Set the date and time

1. Use $\blacktriangle\blacktriangledown$ to adjust the highlighted value.
2. Use $\blacktriangleleft\blacktriangleright$ to move to the other selections and repeat Step 1 until the date and time are set correctly.
3. Press $\frac{\text{Menu}}{\text{OK}}$ when the date, time, and format settings are correct, then press $\frac{\text{Menu}}{\text{OK}}$ again to confirm.

To change the date and time later, use the **Setup Menu** (see *Using the Setup Menu on page 41*).

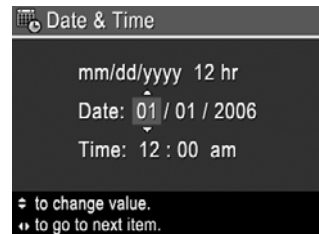

Install and format an optional memory card

1. Turn off the camera and open the Battery/Memory card door.
2. Insert the optional memory card in the smaller slot as shown. Make sure the memory card snaps into place.
3. Close the Battery/Memory card door and turn on the camera.

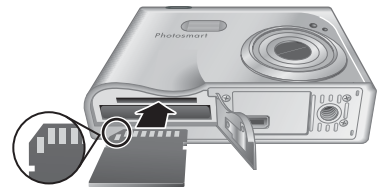

Always format memory cards before first use.

1. With the camera turned on, press $\text{Camera}/\text{Play}$ until Play appears briefly in the upper right corner of the Image Display. This indicates you are in **Playback**.
2. Press \blacktriangledown to access the **Delete** sub-menu.
3. Use \blacktriangledown to select **Format Card**, then press $\frac{\text{Menu}}{\text{OK}}$.
4. Use \blacktriangledown to select **Yes**, then press $\frac{\text{Menu}}{\text{OK}}$ to format the card.



Note Once you install a memory card, all new images and video clips are stored on the card, rather than in internal memory. To use internal memory and view images stored there, remove the memory card. To transfer images from internal memory to an optional memory card, see **Move Images to Card** under *Using the Playback Menu* on page 27.

For information about supported memory cards, see **Storage** under *Specifications* on page 54.

Install the software

The HP Photosmart Software provides features for transferring images and video clips to your computer, as well as features for modifying stored images (remove red eyes, rotate, crop, resize, adjust image quality, and more). See *Transferring images without HP Photosmart Software* on page 35.



Note If you have trouble installing or using the HP Photosmart Software, see the HP Customer Care website for more information: www.hp.com/support.

Windows

If your Windows computer does not meet the system requirements as stated on your camera packaging, HP Photosmart Essential is installed (see *About the HP Photosmart Software* on page 9).

1. Close all programs and temporarily disable any virus protection software.
2. Insert the HP Photosmart Software CD into the CD drive and follow the on-screen instructions. If the installation screen does not appear, click **Start**, click **Run**, type **D:\Setup.exe**, where **D** is the letter of your CD drive, then click **OK**.
3. When the software has finished installing, re-enable virus protection software.

Macintosh

1. Insert the HP Photosmart Software CD into the CD drive.
2. Double-click the CD icon on the computer desktop.
3. Double-click the installer icon, then follow the on-screen instructions.

About the HP Photosmart Software

The CD that came with your camera contains the following versions of HP Photosmart Software:

- HP Photosmart Premier Software (for Windows XP and XP x64 systems with at least 128 MB of RAM). This version of the software includes some extra features that let you:
 - Use the **Share** feature to e-mail images to addresses you specify, create online albums, and automatically print selected images when you connect your camera to your computer. See *Using HP Photosmart Express* on page 38.
 - Automatically stitch panoramas while transferring them to your computer.
 - Print panoramas.
- HP Photosmart Essential Software (for Windows 98, 98SE, Me, and 2000 systems, and for Windows XP systems with less than 128 MB of RAM). This version does not have the extra features specified in HP Photosmart Premier Software.
- HP Photosmart Mac Software (for Macintosh systems).

To learn more about the software features and how to use them, see the **Help** feature in the HP Photosmart Software.

Using your camera

Now that you've completed setup, you can take and review still images and video clips.

For information on taking still pictures and capturing video clips	See <i>Taking still pictures</i> on page 11 and <i>Recording video clips</i> on page 12
For information on reviewing images and video clips on the camera	See <i>Reviewing images and video clips</i> on page 26
For information on enhancing your images	See <i>Using the Design Gallery Menu</i> on page 31
For information on transferring images from your camera to a computer	See <i>Transferring images with HP Photosmart Software</i> on page 35
For information on printing images	See <i>Printing images from the camera</i> on page 36



Tip To switch between **Live View** and **Playback**, press / .

2 Taking pictures and recording video clips

Live View allows you to frame pictures and video clips in the Image Display. To activate **Live View**, press / until appears briefly in the upper right corner of the Image Display. The **Live View** display looks like this:



1		Shooting mode indicator.
2		Memory card indicator.
3		Battery level indicator (see <i>Power indicators</i> on page 51).
4	12	Pictures remaining count.
5		Focus brackets (see <i>Auto focus and exposure</i> on page 12).

Taking still pictures

You can take a picture almost any time the camera is on, regardless of what is shown on the Image Display.

1. Press / until appears briefly in the upper right corner of the Image Display. This indicates you are in **Live View**.
2. Frame the subject for your picture.
3. Press the **Shutter** button halfway down to measure and lock the focus and exposure. The focus brackets in the Image Display turn solid green when focus is locked (see *Auto focus and exposure* on page 12).
4. Press the **Shutter** button all the way down to take the picture.
5. To add an audio clip of up to 60 seconds, continue holding the **Shutter** button down, then release it when done.

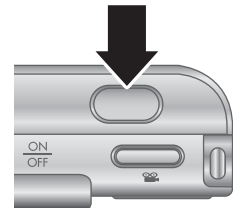

Recording video clips

1. Press / until appears briefly in the upper right corner of the Image Display. This indicates you are in **Live View**.
2. Frame the subject.
3. Press and release the **Video** button.
4. To stop recording video, press and release the **Video** button again.

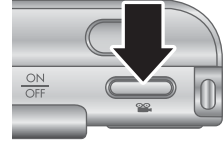

Instant Review

After you have taken a still image or recorded a video clip, the camera displays it in **Instant Review**. If you want to delete the image or video clip, press , select **This Image** from the **Delete** sub-menu, then press .

If appears in the lower left corner, press to display **Image Advice** (see **Image Advice** under *Using the Playback Menu on page 27*) for tips on improving images taken under similar conditions. You can also use these tips to retake the scene and improve the image.

Auto focus and exposure

When you press the **Shutter** button halfway down, the camera automatically measures and locks the focus and exposure. When you auto focus:

Indicator	Description
Green focus brackets	Focus found.
Red focus brackets	Focus not found (see <i>Optimizing focus on page 13</i>).
(shaking hand icon)	Long exposure required (see <i>Optimizing exposure on page 14</i>).

Focusing on the subject

When set to its default **Multi** focus area setting (see **Auto Focus Area** under *Using the Capture Menu on page 20*), the camera uses five focus regions to determine focus.

The 5 focus zones



When you press the **Shutter** button halfway down, the camera focuses from the closest distance, then examines other focus regions, displaying those in focus as green brackets. The sample image shows focus in regions one, two, and five.



If the camera keeps focusing on something other than your subject, set **Auto Focus Area** to **Spot** (see **Auto Focus Area** under *Using the Capture Menu* on page 20), then use **Focus Lock** (see *Using Focus Lock* on page 13).

Optimizing focus

When the camera cannot auto focus, the focus brackets turn red. This indicates the picture may be out of focus because the subject is out of the focus range or the scene has low contrast.

For the Normal Focus range

If the camera is set to **Normal Focus** (see *Using the focus range settings* on page 14) and cannot focus, it will still take the picture. Try releasing the **Shutter** button, reframing, and then pressing the **Shutter** button halfway down again. If the focus brackets are still red:

- If the scene has low contrast, use **Focus Lock** (see *Using Focus Lock* on page 13) and aim at a point on the subject that has more colors or crisp edges.
- If the subject is too close (less than 500 mm or 20 in), move farther away from the subject or use the **Macro** or **Auto Macro** focus range (see *Using the focus range settings* on page 14).
- Use **MF Manual Focus** (see *Using Manual Focus* on page 15).

For the Macro focus range

If the camera is set to **Macro** and cannot focus, the camera will not take the picture. Try one of the following:

- Move within the **Macro** range or set the camera to **Auto Macro** or **AF Normal Focus** (see *Using the focus range settings* on page 14).
- In low contrast scenes, use **Focus Lock** (see *Using Focus Lock* on page 13).
- Use **MF Manual Focus** (see *Using Manual Focus* on page 15).

Using Focus Lock

Use **Focus Lock** to focus on a subject that is not in the center of the picture, to capture action shots more quickly by pre-focusing in the area where the action will occur, or to focus in low light or low contrast situations.

1. Frame the subject for your picture within the focus brackets. In low light or low contrast situations, frame a brighter or higher contrast object.
2. Press the **Shutter** button halfway down.
3. Hold the **Shutter** button halfway down and re-frame.
4. Press the **Shutter** button all the way down to take the picture.



Optimizing exposure

When you press the **Shutter** button halfway down, the camera also measures the light level to set the proper exposure. If the camera determines the scene will require a very long exposure, a shaking hand icon (👋) appears. The camera will take the picture, but it may be blurry because it is difficult to hold the camera still for the length of time required. Try one of the following:

- Set the flash to **Auto Flash** or **Flash On** (see [Setting the flash on page 16](#)).
- Set the camera on a tripod or stable surface.
- Turn on more light.

Other recommendations



If an image does not appear to be in proper focus or exposure when you review it in **Playback**, use **Image Advice** (see **Image Advice** under [Using the Playback Menu on page 27](#)) to help you determine how to correct the problem for similar images in the future. If you can retake an image, you can follow the suggestions in **Image Advice** to improve the image you capture.

Because focus and exposure are crucial to good images, you might find these other topics useful:

- Topics on blurry, dark, light, or grainy images in [Troubleshooting on page 43](#)
- [Using the focus range settings on page 14](#)
- **Auto Focus Area** and **AE Metering** under [Using the Capture Menu on page 20](#)
- [Exposure Compensation on page 24](#)
- [Using Manual Focus on page 15](#)

Using the focus range settings













To select a focus range setting, press 📏, use ◀▶ to highlight the desired focus range, then press ^{Menu}OK.

AF	Normal Focus (Default)—Use when taking pictures of subjects greater than 500 mm (20 in) away.
	Macro —Use when taking close-up pictures of subjects between 100 mm and 1 m (4.7 to 39.4 in) away.
	Auto Macro —Use when you are not sure if the subject is in the Macro or Normal focus range.
	Infinity —Use when taking pictures of distant objects and landscapes.
MF	Manual Focus —Allows you to step manually through the full focus range (see <i>Using Manual Focus</i> on page 15).

The focus range setting remains in effect until it is changed again, or you turn off the camera.

Using Manual Focus

You may want to use **Manual Focus** in low-light conditions or when you want to fine-tune focus of very close-up subjects.

1. When you select **Manual Focus**, a focus meter and a magnified view help you adjust focus.
2. With arrows surrounding the **Manual Focus** meter, use   to adjust the focus. If arrows do not surround the **Manual Focus** meter, use   until they do, then use   to adjust focus.
3. To change shooting modes while using **Manual Focus**, use   until arrows surround the shooting mode icon in the upper left corner, press  , use   to highlight a shooting mode, then press .

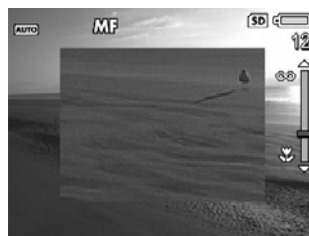

Using zoom



Your camera has both optical and digital zoom. Optical zoom physically extends the lens to make the subject of your picture appear closer. After you have extended the lens fully using optical zoom, the camera employs digital zoom. Digital zoom uses no moving lens parts.



Tip The more you zoom in on the subject of your picture, the more small movements of the camera are magnified (this is called camera shake). If  appears when you press the **Shutter** button halfway down, the picture may be blurry. Be sure to hold the camera still or add more light to the scene. Try holding the camera closer to your body or against a steady object, or set the camera on a tripod or stable surface.

Optical zoom



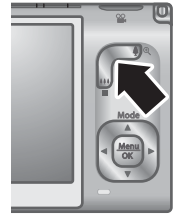

Optical zoom moves the lens between wide angle (1x) and telephoto (3x).

In **Live View**, use the buttons on the **Zoom lever** to control zoom. Press  to zoom in and  to zoom out.



Digital zoom

In digital zoom, the Image Display shows a yellow frame around the scene.

1. In **Live View**, press  on the **Zoom lever** to optically zoom to the maximum level, then release the lever.
2. Press and hold  until the image you want to capture fills the yellow frame. If you zoom in too far, press .
3. To return to optical zoom, press  until digital zooming stops. Release , then press it again.





Note 1 Digital zoom is not available in **Panorama** mode nor when recording video clips.

Note 2 Digital zoom reduces the resolution of an image, so your picture may be more grainy than the same picture taken with optical zoom. When you need higher quality, limit the use of digital zoom.

Setting the flash

To select a flash setting, press , use   to highlight the desired flash mode, then press .

	<p>Auto Flash (Default)—The camera uses the flash, if necessary. If you want the camera to remove red eyes if they exist in images, turn on Red-Eye Removal (see Red-Eye Removal under <i>Using the Capture Menu</i> on page 20). For information about red eye, see <i>Red eye</i> on page 17.</p>
	<p>Flash On—The camera always uses flash. If the light is behind your subject, use this setting to increase the light on the front of your subject. If you want the camera to remove red eyes if they exist in images, turn on Red-Eye Removal (see Red-Eye Removal under <i>Using the Capture Menu</i> on page 20).</p>
	<p>Flash Off—The camera does not use flash. Use this setting to capture poorly lit subjects beyond the flash range or to capture scenes with the existing light.</p>

The **Flash** setting remains in effect until it is changed again, or you turn off the camera.



Note The flash is not available in **Document**, **Landscape**, **Night Scenery**, **Panorama**, **Sunset**, or **Theatre** shooting modes, with the **Burst** setting, nor while recording video clips. In **Night Portrait** shooting mode, the flash is set to **On**.





Red eye











The red-eye phenomenon is caused when light from the flash reflects off the subjects' eyes, which can make human eyes appear red in the captured image. If you turn on  **Red-Eye Removal** (see **Red-Eye Removal** under *Using the Capture Menu on page 20*), the camera examines the image after taking it. If the camera detects red eyes, it then processes the image to remove them.

This examination and processing takes additional time. If you find the additional time too long, you can turn off  **Red-Eye Removal** and remove the red eyes after you have captured the image, using either **Remove Red Eyes** (see **Remove Red Eyes** under *Using the Design Gallery Menu on page 31*) or the HP Photosmart Software that came with your camera.

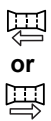



Using the shooting modes

Shooting modes allow you to optimize shutter settings for the scene you are shooting. Most shooting modes predefine these settings for certain types of scenes, allowing you to take pictures quickly when you do not have the time to specify the settings yourself. Other settings (such as **Aperture Priority**, **Shutter Priority**, and **Manual**) let you specify settings, allowing you complete control for difficult scenes or special effects.

To select a shooting mode, press  while in **Live View**, use   to highlight a shooting mode, then press  .

	Auto Mode (Default)—For taking good shots quickly, when you do not have time to select a special shooting mode.
	Landscape —For scenes with deep perspective, such as mountain scenes.
	Portrait —For pictures that have one or more people as their primary subject.
	Theatre —For capturing images at school programs, concerts, or indoor sporting events without using flash.
 or 	Panorama —For grand landscapes or group pictures where you need to capture a wide shot that one image cannot capture (see <i>Using Panorama mode on page 18</i>).
	Action —For capturing sporting events, moving cars, or any scene where you want to stop the action.
	Night Portrait —For capturing images of people at night. This mode uses the flash and a long exposure. As a result, you must set the camera on a tripod or stable surface.
	Night Scenery —For capturing night scenes. This mode uses a long exposure with no flash. As a result, you must set the camera on a tripod or stable surface.
	Beach —For capturing scenes at the beach.

(continued)

	Snow —For capturing scenes in snow.
	Sunset —For capturing outdoor scenes at sunset.
	Document —For capturing flat, textual, or graphical pieces.
Av	Aperture Priority —For specifying the aperture setting. This mode lets you select the F-number (aperture) setting using ▲▼, while the camera selects the best shutter speed. If the image will be over- or under-exposed more than 0.5 stops, the F-number and shutter speed turn red. Adjust the F-number until these items turn white. To change to a different shooting mode, press ◀▶ until arrows surround the shooting mode, then press ▲.
Tv	Shutter Priority —For specifying the shutter speed. This mode lets you select the shutter speed using ▲▼, while the camera selects the best F-number. If the image will be over- or under-exposed more than 0.5 stops, the F-number and shutter speed turn red. Adjust shutter speed until these items turn white. To change to a different shooting mode, press ◀▶ until arrows surround the shooting mode, then press ▲.
M	Manual —For specifying both F-number and shutter speed (see Using Manual shooting mode on page 19).
	My Mode —For a customizable shooting mode that lets you select, save, and then repeatedly use a group of preferred settings (see Using My Mode on page 19).



Note The shooting modes do not apply when you are recording video clips.

The shooting mode remains in effect until it is changed again, or until you turn off the camera.

Using Panorama mode

Panorama mode allows you to take a sequence of 2 to 5 pictures that can be stitched together to capture a scene too wide to fit into a single picture. To stitch your panoramic sequence together, use **Stitch Panorama** on the camera (see [Stitching panoramas on page 29](#)). Depending on the HP Photosmart Software version you installed (see [About the HP Photosmart Software on page 9](#)), you can also stitch panoramas automatically as you transfer them to your computer.

1. While in **Live View**, press ▲, use ▲▼ to select either  **Panorama** (left to right) or  **Panorama** (right to left), then press .
2. Press the **Shutter** button to take the first picture in the panoramic sequence.

- Position the camera to take the second picture. Use the transparent overlay of the first image superimposed on one third of the **Live View** screen to align your second picture with the first.
- Press the **Shutter** button to take the second picture.
- Continue adding more pictures to the panorama, or press $\frac{\text{Menu}}{\text{OK}}$ to end the panoramic sequence.

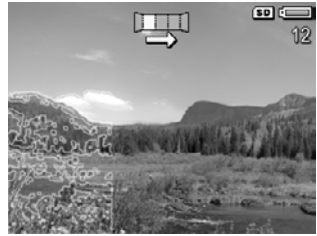

During **Instant Review** (see [Instant Review on page 12](#)), each image in the panoramic sequence is displayed. When the last image is displayed, you can stitch the sequence by pressing \blacktriangleleft , then pressing $\frac{\text{Menu}}{\text{OK}}$ when the stitched panorama appears. You can also delete the panoramic sequence by pressing \blacktriangledown , selecting **Entire Panoramic Sequence**, then pressing $\frac{\text{Menu}}{\text{OK}}$.



Note To add audio to images taken in **Panorama** mode, see [Recording audio on page 30](#).

Using Manual shooting mode

Manual mode lets you specify both F-number (aperture) and shutter speed.

- While in **Live View**, press \blacktriangle , use $\blacktriangle\blacktriangledown$ to highlight **M**, then press $\frac{\text{Menu}}{\text{OK}}$.
- Frame the subject for your picture.
- Use $\blacktriangleleft\blacktriangleright$ to switch between F-number and shutter speed.
- Use $\blacktriangle\blacktriangledown$ to adjust the value of the selected option. The arrow on the exposure meter indicates the amount of over- or under-exposure. If the image will be over- or under-exposed more than three stops, the F-number and shutter speed turn red. Adjust either the F-number or shutter speed until these items turn white.
- If you want to change to a different shooting mode, use $\blacktriangleleft\blacktriangleright$ to select **M**, then press \blacktriangle .



The **Manual** shooting mode settings remain in effect until they are changed again, even when you turn off the camera.

Using My Mode

My Mode is a customizable shooting mode that allows you to select, save, and reuse a group of preferred settings. You can specify a shooting mode (see [Using the shooting modes on page 17](#)), **Capture Menu** options (see [Using the Capture Menu on page 20](#)), and which settings are saved in **My Mode**.

The settings in **My Mode** are independent from all other shooting mode settings and are saved when you turn off the camera.

Selecting and saving preferred settings in My Mode

1. While in **Live View**, press \blacktriangle , use $\blacktriangle/\blacktriangledown$ to highlight **MY My Mode**, then press $\frac{\text{Menu}}{\text{OK}}$ twice to display the **My Mode Capture Menu**.
2. Use $\blacktriangle/\blacktriangledown$ to highlight **MY My Shooting Mode**, press $\frac{\text{Menu}}{\text{OK}}$, use $\blacktriangle/\blacktriangledown$ to select a shooting mode to use in **My Mode**, then press $\frac{\text{Menu}}{\text{OK}}$ to return to the **My Mode Capture Menu**.
3. Use $\blacktriangle/\blacktriangledown$ to highlight another menu option, press $\frac{\text{Menu}}{\text{OK}}$, use $\blacktriangle/\blacktriangledown$ to highlight a setting, then press $\frac{\text{Menu}}{\text{OK}}$ to select that setting and return to the **My Mode Capture Menu**.
4. Repeat step 3 to specify other menu options you want to set for **My Mode**.
5. Press CAM/DISP to exit the **My Mode Capture Menu**.

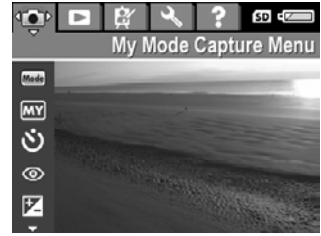

Using the My Mode Saved Settings sub-menu

The **My Mode Saved Settings** sub-menu allows you to specify which settings are saved in **My Mode**. You can also specify that the camera start in **My Mode** instead of **Auto Mode** each time you turn on the camera.

1. While in **Live View**, press \blacktriangle , use $\blacktriangle/\blacktriangledown$ to highlight **MY**, then press $\frac{\text{Menu}}{\text{OK}}$ twice.
2. Use $\blacktriangle/\blacktriangledown$ to scroll to the **My Mode Saved Settings** menu option, then press $\frac{\text{Menu}}{\text{OK}}$. The **My Mode Saved Settings** sub-menu displays. The options with check marks will be saved in **My Mode** any time you turn off the camera.
3. To specify that a setting return to its default when you turn off the camera or to specify that the camera start in **My Mode** each time you turn on the camera:
 - a. Use $\blacktriangle/\blacktriangledown$ to scroll to the setting.
 - b. Use $\blacktriangle/\blacktriangledown$ to either remove the check mark next to a setting or switch the **Start in My Mode** setting to **Yes**.
4. Repeat Step 3 for each setting you want to change.
5. Press $\frac{\text{Menu}}{\text{OK}}$ to return to the **My Mode Capture Menu**.
6. To exit the **My Mode Capture Menu**, press CAM/DISP .

Using the Capture Menu

The **Capture Menu** allows you to adjust camera settings that affect the characteristics of the images and video clips you capture.

1. While in **Live View**, press $\frac{\text{Menu}}{\text{OK}}$ to display the **Capture Menu**.
2. Use $\blacktriangle/\blacktriangledown$ to highlight a menu option, then press $\frac{\text{Menu}}{\text{OK}}$ to display the menu option's sub-menu.
3. Use $\blacktriangle/\blacktriangledown$ to highlight a setting, then press $\frac{\text{Menu}}{\text{OK}}$.
4. Press CAM/DISP to exit the **Capture Menu**.

For on-camera information about an option, use $\blacktriangle/\blacktriangledown$ to highlight **Help...** in the option's sub-menu, then press $\frac{\text{Menu}}{\text{OK}}$.







Mode

Shooting Modes—For selecting a shooting mode. For information about shooting modes and another way to select them, see [Using the shooting modes on page 17](#).





(continued)

	<p>Self-Timer—For capturing images or recording video after a 10-second delay (see Using the Self-Timer settings on page 23).</p> <ul style="list-style-type: none">● Off (Default)—Disables Self-Timer.● On—For taking one delayed shot or video clip.● On - 2 Shots—For taking two delayed shots or one video clip.
	<p>Red-Eye Removal—For automatically removing red eyes when flash is set to Auto or Flash On and the camera detects red eyes. For information about red eyes, see Red eye on page 17.</p> <p>On, Off (Default)</p>
	<p>Exposure Compensation—Overrides the camera's automatic exposure setting. For more information, see Exposure Compensation on page 24.</p> <ul style="list-style-type: none">● To make the images you are about to capture brighter, press ▶ to increase the value.● To make the images you are about to capture darker, press ◀ to decrease the value.
	<p>Adaptive Lighting—Balances the relationship between light and dark areas. For more information, see Adaptive Lighting on page 24.</p> <ul style="list-style-type: none">● Off (Default)—Processes the image as normal.● Low—Gently brightens dark regions.● High—Greatly brightens dark regions.
	<p>Bracketing—Creates a set of three images, each set to a different value.</p> <ul style="list-style-type: none">● Off (Default)—Processes the image as normal.● Adaptive Lighting—Images created with Adaptive Lighting set to Off, Low, and High.● Exposure—Images created at value set for Exposure Compensation and under- and over-exposed by the value you select using ◀▶.● Color—Images created in full color, black & white, and sepia. <p>During Instant Review (see Instant Review on page 12), you can delete the entire bracketing sequence. To delete individual images, see Deleting images on page 28.</p>
	<p>Image Quality—Sets resolution and compression for images. The greater the number, the higher the resolution. The fewer stars, the greater the compression (see Image quality on page 56).</p> <ul style="list-style-type: none">● 8MP ★★★—For enlarging or printing images greater than 41 x 51 cm (16 x 20 in).● Normal (8MP ★★) (Default)—For printing images up to 41 x 51 cm (16 x 20 in).● 5MP ★★—For printing images up to 28 x 36 cm (11 by 14 in).● 2MP ★★—For printing images up to 13 x 18 cm (5 by 7 in).● VGA ★★—For sending images via e-mail or posting them to the Internet.● Custom...—For specifying a custom combination of resolution (8MP, 5MP, 2MP, VGA) and compression (★ to ★★★★★). Use ▲▼ to move between Resolution and Compression, and ◀▶ to specify a setting.

(continued)

	<p>Video Quality—Sets resolution and compression for video clips. The fewer stars, the greater the compression.</p> <ul style="list-style-type: none"> • Normal (VGA ★★★) (Default)—For outdoor action video clips or printing individual video frames up to 10.2 by 15.2 cm (4 by 6 in). • VGA ★★—For indoor video clips or printing individual video frames up to 7.6 by 12.7 cm (3 by 5 in). • QVGA ★—For capturing longer video clips or e-mailing shorter clips.
	<p>Burst—For taking two or more shots quickly in succession (see Using the Burst setting on page 24).</p> <p>On, Off (Default)</p>
	<p>White Balance—Balances color based on lighting conditions. For more information, see White Balance on page 25.</p> <ul style="list-style-type: none"> • Auto (Default)—Corrects for scene illuminance. For general picture taking. • Sun—For outdoor scenes in sunny or cloudy conditions. • Shade—For outdoor scenes in shade or at dusk. • Tungsten—For indoor scenes with incandescent or halogen lighting. • Fluorescent—For indoor scenes with fluorescent lighting. • Manual—For setting a custom White Balance based on your target subject. To set the white balance, select Manual, then follow the on-screen instructions.
	<p>Auto Focus Area—Selects between a wide, multi-zone focus region and a spot focus region. For more information, see Focusing on the subject on page 12.</p> <ul style="list-style-type: none"> • Multi (Default)—Use this setting for general-purpose picture taking or to focus on a subject not in the center of the scene. The camera searches for focus in each of five zones. • Spot—Use this setting when the camera keeps focusing on something other than your subject. The camera focuses on a small area in the center of the scene.
	<p>AE Metering—Specifies which region of a scene the camera uses to calculate the exposure.</p> <ul style="list-style-type: none"> • Average—Useful when you want the entire scene to be used when calculating exposure. • Center-Weighted (Default)—Useful when the subject of the picture is in the center of the scene. Exposure is based more on the subject than its surroundings. • Spot—Useful in backlit scenes or when the subject is very dark or light compared to the rest of the scene. For best results, use Focus Lock (see Using Focus Lock on page 13) with Spot.
	<p>ISO Speed—Adjusts the camera's sensitivity to light. For more information, see ISO speed on page 25.</p> <ul style="list-style-type: none"> • Auto (Default)—Camera selects the best ISO speed for scene. • ISO 100—For best quality.

(continued)















	<ul style="list-style-type: none">● ISO 200—For lower light conditions.● ISO 400—For lower light conditions and/or action when short shutter speeds are desired.
	<p>Saturation—Controls the saturation of colors in your pictures.</p> <ul style="list-style-type: none">● Low—Mutes colors to give a softer, more natural look to the subject.● Medium (Default)—Leaves colors normally saturated.● High—Emphasizes more vivid colors.
	<p>Sharpness—Controls how sharp the fine detail is in your images.</p> <ul style="list-style-type: none">● Low—For taking portrait pictures with softer, more natural edges.● Medium (Default)—For edges with normal sharpness.● High—For images with crisp edges.
	<p>Contrast—Controls amount of contrast between light and dark colors.</p> <ul style="list-style-type: none">● Low—Dark and light colors in the image are less distinct, and highlights and shadows have more detail.● Medium (Default)—Images have normal contrast.● High—Dark and light colors in the image are more distinct, and highlights and shadows have less detail.
	<p>Date & Time Imprint—Imprints date in lower left corner of image.</p> <ul style="list-style-type: none">● Off (Default)—No date or time imprinted on the image.● Date Only—Date permanently imprinted.● Date & Time—Date and time permanently imprinted.



Note Some **Capture Menu** options are not available in certain shooting modes or in combination with other **Capture Menu** options. In addition, some do not apply when recording video clips.

Using the Self-Timer settings

The Self-Timer allows you to take an image or video clip 10 seconds after pressing the **Shutter** or  **Video** button.

1. While in **Live View**, press  to display the **Capture Menu**, use   to highlight  **Self-Timer**, press  , use   to select **On** (for one shot) or **On - 2 Shots**, press  , then press  / . For more details on selecting options in the **Capture Menu**, see [Using the Capture Menu on page 20](#).
2. Set the camera on a tripod or stable surface.
3. Frame the subject in the Image Display.
4. The next steps depend on whether you are taking one or two still pictures, or recording a video clip.
 - a. For still pictures, press the **Shutter** button halfway down to lock focus and exposure. When the focus brackets turn green, press the **Shutter** button all the way down.
 - b. For video clips, press the  **Video** button, then release it.
5. The camera begins the 10-second countdown, then takes the still image or begins recording the video clip. If you chose **On - 2 Shots** and are taking a still image, the camera takes the second still image a few seconds after the first.
6. If you are recording a video clip, press the  **Video** button to stop recording.



Tip If you want to include yourself in the picture, press the **Shutter** button all the way down, then place the camera on a tripod or stable surface. The camera locks focus and exposure just before the end of the countdown, allowing you time to place yourself in the scene.





Note To add audio to images taken with the **Self-Timer** setting, see [Recording audio on page 30](#).

The **Self-Timer** setting resets to the default **Off** setting after the picture or video clip is taken.

Using the Burst setting

Burst allows you to take two or more pictures as quickly as possible when you press and hold the **Shutter** button all the way down.

1. While in **Live View**, press $\frac{\text{Menu}}{\text{OK}}$ to display the **Capture Menu**, use $\blacktriangle/\blacktriangledown$ to highlight  **Burst**, press $\frac{\text{Menu}}{\text{OK}}$, use $\blacktriangle/\blacktriangledown$ to select **On**, press $\frac{\text{Menu}}{\text{OK}}$, then press  / . For more details on selecting options in the **Capture Menu**, see [Using the Capture Menu on page 20](#).
2. Frame the subject, then press the **Shutter** button halfway down to lock the focus and exposure. Then press the **Shutter** button all the way down and hold it. The camera takes pictures as quickly as possible until you release the **Shutter** button or the camera runs out of memory.

The Image Display remains off during the burst capture. After the burst images have been taken, each image appears one at a time in **Instant Review** (see [Instant Review on page 12](#)). You can delete the entire burst sequence in **Instant Review**. To delete individual images, see [Deleting images on page 28](#).

To add audio to images taken with the **Burst** setting, see [Recording audio on page 30](#).

The **Burst** setting remains in effect until it is changed again, or until it resets to the default **Off** setting when you turn off the camera.

Exposure Compensation

You can use **Exposure Compensation** to override the camera's automatic exposure setting. **Exposure Compensation** is useful in scenes that contain many light objects (like a white object against a light background) or many dark objects (like a black object against a dark background). Such scenes could turn out gray without the use of **Exposure Compensation**. For a scene with many light objects, increase the **Exposure Compensation** to a positive number. For a scene with many dark objects, decrease the **Exposure Compensation**.



Tip To see the effect varying **Exposure Compensation** settings might have on a scene, try the **Exposure** option in **Bracketing** (see **Bracketing** under [Using the Capture Menu on page 20](#)).

Adaptive Lighting

This setting balances the relationship between bright and dark areas in a picture, preserving gentle contrasts while reducing harsh contrasts. When used with a flash,

Adaptive Lighting can brighten areas that a flash wouldn't reach. **Adaptive Lighting** is useful in situations like these:

- Outdoor scenes with a mixture of sun and shade
- Cloudy days when there is a lot of glare from the sky
- Indoor scenes that use flash photography (to soften or even out the effect of the flash)
- Backlit scenes where the subject is too far away for the flash to reach, or is severely backlit (for example, in front of a window)

You can use **Adaptive Lighting** with or without flash, but it is not recommended as a replacement for flash. Unlike the flash, **Adaptive Lighting** does not affect exposure settings, so brightened areas may appear noisy or grainy, and indoor or night images may be blurry if taken without a flash or a tripod.



Tip To see the effect the **Adaptive Lighting** settings might have on a scene, use the **Adaptive Lighting** option in **Bracketing** (see **Bracketing** under *Using the Capture Menu* on page 20).

White Balance

Different lighting conditions cast different colors. This setting allows the camera to compensate for this, reproducing colors more accurately and ensuring that whites appear white in the final image. You can also adjust the white balance to produce creative effects. For example, the **Sun** setting produces a warmer look to the image.

ISO speed

This setting adjusts the sensitivity of the camera to light. When **ISO Speed** is set to the default **Auto** setting, the camera selects the best ISO speed for the scene.

Lower ISO speeds capture images with the least amount of grain (or noise), but result in slower shutter speeds. If taking a picture in low light conditions without a flash at **ISO 100**, use a tripod.

Higher ISO numbers allow faster shutter speeds, and can be used when taking pictures in dark areas without a flash, or when taking pictures of fast moving objects. Higher ISO speeds produce pictures with more grain (or noise) and, therefore, can be of lower quality.

3 Reviewing images and video clips

You can review and manipulate images and video clips in **Playback** as described here. For information about enhancing images, see *Using the Playback Menu* on page 27 and *Using the Design Gallery Menu* on page 31.

Using Playback

1. Press / until appears briefly in the upper right corner of the Image Display.
2. Use to scroll through your images and video clips (video clips play automatically).
When viewing video clips, press to pause the clip, then use to scroll through the individual frames.
3. To switch to **Live View**, press / .

During **Playback**, the Image Display also indicates additional information about each image or video clip.



1		Memory card indicator.
2		Battery indicator (see <i>Power indicators</i> on page 51).
3		Image position in a panoramic sequence.
4		Number of electronic Photosmart Share destinations (see <i>Using HP Photosmart Express</i> on page 38).
5		Number of images to print (see <i>Transferring and printing images</i> on page 35).
6	0:15 	<ul style="list-style-type: none"> Recorded length of this audio or video clip. Attached audio clip indicator. Video clip indicator.
7	1 of 30	Number of this image or video clip out of the total number of stored images and video clips.

Saving frames from video clips

If you want to print a frame from a video clip, you can save an individual frame as a still image.

1. During video playback, press $\frac{\text{Menu}}{\text{OK}}$ to pause the video.
2. Use $\blacktriangleleft\blacktriangleright$ to scroll one frame at a time.
3. Press \blacktriangleup to save the displayed frame.
4. Press CAM/PLAY to resume playing the video clip.

Viewing thumbnails

1. While in **Playback**, press THUMB **Thumbnails** (same as **Zoom Out** ZOOM on the **Zoom lever**) to view thumbnails.
2. Use $\blacktriangleup\blacktriangledown$ and $\blacktriangleleft\blacktriangleright$ to scroll through the thumbnails.
3. Press $\frac{\text{Menu}}{\text{OK}}$ to exit **Thumbnails** and view the highlighted image on the Image Display.



Magnifying images



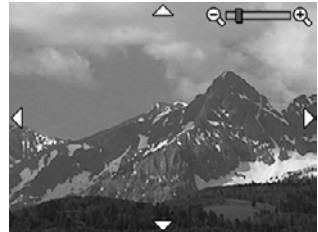

This feature is for viewing purposes only; it does not permanently alter the image.

1. While in **Playback**, press MAG (same as **Zoom In** ZOOM on the **Zoom lever**). The currently displayed image is magnified 2x.
2. Use $\blacktriangleup\blacktriangledown$ and $\blacktriangleleft\blacktriangleright$ to pan around the magnified image.
3. Use \uparrow and ZOOM to change the magnification.
4. Press $\frac{\text{Menu}}{\text{OK}}$ to return to **Playback**.





Using the Playback Menu

1. While in **Playback**, press $\frac{\text{Menu}}{\text{OK}}$.
2. Use $\blacktriangleup\blacktriangledown$ to highlight an option.
3. Use $\blacktriangleleft\blacktriangleright$ to select an image or video clip, press $\frac{\text{Menu}}{\text{OK}}$, and follow the on-screen instructions.
4. Press CAM/PLAY to exit the **Playback Menu**.













	Delete —See Deleting images on page 28.
	Image Advice —Analyzes image for focus, exposure, and so forth.
	Image Info —See Viewing image information on page 28.
	View Slideshow —See Viewing slideshows on page 29.

(continued)



	Stitch Panorama —See <i>Stitching panoramas</i> on page 29.
	Record Audio —See <i>Recording audio</i> on page 30.
	Move Images to Card —Moves images from internal memory to memory card. Available only if there are images in internal memory and a memory card is inserted. To move images, select this option and follow the on-screen prompts.

Deleting images

To delete an image using the  **Delete** option on the **Playback Menu**:

1. While in **Playback**, use   to scroll to the image you want to delete, then press   to display the **Playback Menu**.
2. Press  to highlight  **Delete**, then press  .
3. Use   to select an option, then press  .
 - **Cancel**—Returns to **Playback** without deleting the displayed image.
 - **This Image**—Deletes the image or video clip.
 - **Entire Panoramic Sequence**—If the current image is part of a panoramic sequence, deletes all images in the panoramic sequence.
 - **All Images (in Memory/on Card)**—Deletes all stored images and video clips.
 - **Format (Memory/Card)**—Deletes all stored files, then formats the internal memory or memory card.



Tip To delete a displayed image while in **Playback**, press , select an option, then press  .

Viewing image information

The **Image Info** screen shows the settings used when capturing the currently displayed image or video clip.



1	Shutter speed and F-number (aperture).
2	ISO Speed.

(continued)

3	Non-default shooting mode (see <i>Using the shooting modes</i> on page 17), Flash (see <i>Setting the flash</i> on page 16), and Focus setting (see <i>Using the focus range settings</i> on page 14).
4	All non-default Capture Menu settings except Self-Timer and Burst .
5	Histogram displaying, left to right, the distribution of dark, mid-range, and light pixels in the captured image.
6	Memory card indicator.
7	File name of the image.
8	File size of the image.
9	Date and time image was captured.
10	Image Quality setting at which the image was captured.
11	The information in the two rows in the bottom, right corner of the image is the same provided in Playback .

Viewing slideshows

Select **View Slideshow** to configure and run a slideshow of images and/or video clips on the camera Image Display or on a TV (if the camera is docked in an optional HP Photosmart premium dock or wireless dock base and connected to a TV).

- **Cancel**—Returns to the **Playback Menu** without viewing the slideshow.
- **Start Slideshow**—Starts the slideshow.
- **Images**—Plays the specified images: **All** (default), **Stills Only**, **This Image**, **Videos Only**.
- **Interval**—Sets the amount of time each image is shown: **2 secs**, **5 secs** (default), **10 secs**, **15 secs**, **60 secs**.
- **Loop**—Specifies how often the slideshow repeats: **Once** (default), **2x**, **3x**, **Continuous**.
- **Audio**—Plays associated audio clips at the specified volume: **Off**, **Low**, **High**.





Stitching panoramas



When an image from a panoramic sequence is displayed and you select **Stitch Panorama**, the camera displays a stitched view of the panoramic sequence.



Note Stitching on-camera could result in a smaller image than if you stitched when uploading to a computer. To stitch a panorama at the resolution at which you took the panoramic sequence, transfer the panoramic sequence of images to your computer (see *Transferring images with HP Photosmart Software* on page 35).

1. Scroll to one of the images in a panoramic sequence.
2. Use ▲▼ to select **Stitch Panorama**, then press $\frac{\text{Menu}}{\text{OK}}$ to view a preview of the stitched image.



You can use  to magnify the stitched panorama, and     to pan around the image and examine the stitching.

3. Press  to save the stitched panoramic image; press  to cancel panorama stitching.

When you stitch a panorama, individual images in the panoramic sequence are retained.

Recording audio

 **Record Audio** allows you to record an audio clip and attach it to an existing image or panoramic sequence.

1. Select  **Record Audio** to immediately start recording.
2. To stop recording and attach the audio clip to the displayed image, press .



Note You can attach audio clips to individual images in a panoramic sequence. When you stitch the panoramic sequence (on-camera or on-computer), no audio is attached to the stitched image. You can, however, add audio to a stitched panorama as previously described.







If the currently displayed image already has an audio clip attached to it, the **Record Audio** sub-menu displays instead when you select  **Record Audio**.

- **Keep Current Clip**—Retains the current audio clip and returns to the **Playback Menu**.
- **Record New Clip**—Records a new audio clip, replacing the previous audio clip.
- **Delete Clip**—Deletes the current audio clip and returns to the **Playback Menu**.

4 Using the Design Gallery Menu

You can use the **Design Gallery** features to enhance your captured images.

1. While in **Playback**, use ◀▶ to scroll to an image, then press $\frac{\text{Menu}}{\text{OK}}$.
2. Use ◀▶ to highlight the  **Design Gallery Menu** tab.
3. Use ▲▼ to highlight an option, then press $\frac{\text{Menu}}{\text{OK}}$ and follow the on-screen instructions.

	Apply Artistic Effects —See <i>Applying artistic effects</i> on page 31.
	Modify Color —See <i>Modifying colors</i> on page 32.
	Add Borders —See <i>Adding borders</i> on page 32.
	Remove Red Eyes —See <i>Removing red eyes</i> on page 33.
	Rotate —Rotates the displayed image. Use ◀▶ to rotate the image clockwise or counter-clockwise in 90-degree increments. Press $\frac{\text{Menu}}{\text{OK}}$ to save the image in the new orientation.
	Crop —See <i>Cropping images</i> on page 33.



Applying artistic effects



Tip If you need to crop an image (see *Cropping images* on page 33), do so before applying artistic effects or adding borders.

 **Apply Artistic Effects** allows you to create a copy of a selected image and apply creative effects to the copy. To apply artistic effects:

1. Use ▼ to select  **Apply Artistic Effects**, then press $\frac{\text{Menu}}{\text{OK}}$.
2. Use ▲▼ to select an option and preview the effect it has on the image.
 - **Cancel**—Returns to the **Design Gallery Menu** without saving changes.
 - **Ink Dots**—Simulates monochrome pointillism. You can select one ink color and one paper color separately.
 - **Cartoon**—Simulates a highly-graphical comic book image.
 - **Watercolor**—Simulates a watercolor painting.
 - **Center Focus**—Creates a feathered blur radiating from a sharp center to a blurred edge.
 - **Posterize**—Creates a high-contrast, flat-toned effect.
 - **Retro**—Creates a two-color, high-contrast look from the 70s.
 - **Soft Glow**—Creates a diffuse, bright ethereal glow.
 - **Vintage**—Adds an aged, scratched look.
 - **Slimming**—Compresses centered subjects for a slimmer look.
 - **Sky Color**—Enhances sky with a feathered color that fades from the top down.
 - **Ground Color**—Enhances landscapes with a feathered color that fades from the bottom up.

- **Kaleidoscope**—Mirrors the image in four directions.
 - **Solarize**—Creates a partial reversal of tones and emphasizes outlines.
3. Press $\frac{\text{Menu}}{\text{OK}}$ to select the artistic effect and display the creative sub-menu. Follow the on-screen instructions to adjust the artistic effect.
 4. Press $\frac{\text{Menu}}{\text{OK}}$ to save a copy of the image with the artistic effect and return to the **Design Gallery Menu**. Press  /  to exit without saving and return to the **Apply Artistic Effects** sub-menu.

Modifying colors

 **Modify Color** allows you to apply color schemes to the displayed image. To modify colors:

1. Use \blacktriangledown to select  **Modify Color**, then press $\frac{\text{Menu}}{\text{OK}}$.
2. Use $\blacktriangle\blacktriangledown$ to select a color scheme and preview the effect it has on the image.
 - **Cancel**—Returns to the **Design Gallery Menu** without saving changes.
 - **Black & White**—Converts color images to black and white.
 - **Sepia**—Converts image to a brownish tone to look old-fashioned.
 - **B&W Tints**—Applies color tones on a black and white version of an image.
 - **Color Tints**—Adds an extra color layer to create a mood or feeling.
3. Press $\frac{\text{Menu}}{\text{OK}}$ to select the color scheme and display the creative sub-menu. Follow the on-screen instructions to adjust the color.
4. Press $\frac{\text{Menu}}{\text{OK}}$ to save a copy of the image with the specified color scheme and return to the **Design Gallery Menu**. Press  /  to exit without saving and return to the **Modify Color** sub-menu.

Adding borders



Tip If you need to crop an image (see [Cropping images on page 33](#)), do so before adding borders or applying artistic effects.

 **Add Borders** allows you to add a predefined border to the displayed image. To add a border:

1. Use \blacktriangledown to select  **Add Borders**, then press $\frac{\text{Menu}}{\text{OK}}$.
2. Use $\blacktriangle\blacktriangledown$ to select a border type and preview the effect it has on the image.
 - **Cancel**—Returns to the **Design Gallery** menu without saving changes.
 - **Soft Edge**—Applies a soft, vignetted frame to the image.
 - **Inset Border**—Image extends beyond the inset frame.
 - **Torn Edge**—Creates random tears for an uneven border effect.
 - **Burn Edge**—Applies a border with darkened areas that appear burned.
 - **Spatter**—Creates an edge that appears to dissolve into the paper, like spray.
 - **Oval**—Adds an oval matte border with beveled edges.
 - **Circle**—Adds a circular matte border with beveled edges.
 - **Rectangle**—Adds a rectangular matte border with sharp corners.
 - **Rounded Rectangle**—Uses a rectangle with soft corners for the matte border.
 - **Square**—Adds a square matte border with beveled edges.
3. Press $\frac{\text{Menu}}{\text{OK}}$ to select the border and display the creative sub-menu.

- Follow the on-screen instructions to adjust the border.
4. Press $\frac{\text{Menu}}{\text{OK}}$ to save a copy of the image with the specified border and return to the **Design Gallery Menu**. Press \square/\blacksquare to exit without saving and return to the **Add Borders** sub-menu.

Removing red eyes

When you select  **Remove Red Eyes**, the camera processes the current still image to remove red eyes from the subjects.



Note To prevent red eyes in images, see **Red-Eye** under *Setting the flash* on page 16.

The red-eye removal process takes a few seconds, after which the image displays with green boxes around corrected areas, along with the **Remove Red Eyes** submenu:

- **Save Changes** (Default)—Overwrites the original image and returns to the **Design Gallery Menu**.
- **View Changes**—Displays a magnified view of the image with green boxes around the corrected areas.
- **Cancel**—Returns to the **Design Gallery Menu** without saving the red eye changes.

To undo redeye removal, select **Undo Redeye Removal** from the **Design Gallery Menu**, then press $\frac{\text{Menu}}{\text{OK}}$.



Note **Undo Redeye Removal** only appears on the **Design Gallery Menu** if you are viewing an image on which you have already performed red-eye removal.

Remove Red Eyes is only available for still images taken with a flash.

Cropping images

 **Crop** allows you to crop the displayed image to the selected orientation, then use the **Zoom lever** and $\blacktriangle\blacktriangledown\blacktriangleleft\blacktriangleright$ to ensure that the image content you want gets printed.





Tip Make sure you crop images as needed before adding borders or applying artistic effects.

1. Use \blacktriangledown to select  **Crop**, then press $\frac{\text{Menu}}{\text{OK}}$.
2. Use $\blacktriangle\blacktriangledown$ to select a crop orientation and preview the effect it has on the image.
 - **Cancel**—Returns to the **Design Gallery Menu** without saving changes.
 - **Landscape** (Default)—Horizontally crops the displayed image to a 3:2 aspect ratio (one third wider than tall).
 - **Portrait**—Vertically crops the displayed image to a 2:3 aspect ratio (one-third taller than wide).
 - **Help**—Provides extended help information for the **Crop** function.

Follow the on-screen instructions to use the **Zoom lever** and adjust what appears in the cropped image.

When you print, the normal aspect ratios get cropped on the top and bottom (landscape) or on the sides (portrait). Cropping helps ensure that the content you want gets printed.

3. Press $\frac{\text{Menu}}{\text{OK}}$ to save a copy of the cropped image and return to the **Design Gallery Menu**. Press  /  to exit without saving and return to the **Crop** sub-menu.

5 Transferring and printing images

You can transfer images and video clips with or without the HP Photosmart Software that came with your camera. However, the HP Photosmart Software has several features for transferring and managing your images and also guides you through the transfer process.

Transferring images with HP Photosmart Software

If you have installed the HP Photosmart Software (see [Install the software on page 9](#)), use this method to transfer images and video clips to your computer. Depending on the HP Photosmart Software version you installed (see [About the HP Photosmart Software on page 9](#)), you can also use this method to transfer, stitch, and print panoramas.

1. If you have selected images for sharing or printing (see [Selecting individual images for printing on page 39](#)), verify that the computer is connected to a printer and/or the Internet.
2. Connect the dock and printer using the USB cable that came with your camera.
3. Place the camera in the dock.
4. Turn on the camera and follow the instructions on the computer screen to transfer the images. For more information, see the Help feature in the HP Photosmart Software.



Transferring images without HP Photosmart Software

If you do not install the HP Photosmart Software:

- You cannot use the **Share** features or **Buy Prints Online** on the camera's **Photosmart Express Menu** (see [Using HP Photosmart Express on page 38](#)).
- Panoramic sequences are not automatically stitched when you transfer the images to your computer.
- Images marked for printing do not automatically print when the camera is connected to the computer.

However, you can still transfer images and video clips to your computer by:

- Connecting your camera directly to the computer (see [Connecting to the computer on page 36](#))
- Using a memory card reader (see [Using a memory card reader on page 36](#))

Connecting to the computer

1. Turn off the camera, connect the dock to your computer and place the camera in the dock.
 - On Windows computers, the camera appears as a device in Explorer, allowing you to copy images from the camera to the computer.
 - On Macintosh computers, either Image Capture or iPhoto starts automatically, allowing you to transfer images to the computer.
2. When you have finished transferring images, remove the camera from the dock. If your computer is running Windows 2000 or XP and you get an **Unsafe Removal** warning, disregard the warning.

If you encounter problems, set the camera's **USB Configuration to Disk Drive** (see **USB Configuration** under *Using the Setup Menu on page 41*) and reconnect to your computer.



Note On Macintosh computers, if you set the camera to **Disk Drive** and neither Image Capture nor iPhoto starts automatically, look on the desktop for a disk drive icon with the label **HP_R927** and copy the images manually. For more information about how to copy files, visit Mac help.

Using a memory card reader

You can put your camera's optional memory card into a (separately purchased) memory card reader. Some computers and HP Photosmart printers have built-in memory card slots which act as a memory card reader.

For Windows computers:

1. Insert your camera's memory card into the memory card reader (or into your computer's memory card slot).
2. Right-click **My Computer** on your desktop, then select **Explore**.
3. Expand the removable drive folder, expand the **DCIM** folder, then click on the folder for your camera.
4. Select and copy all the images to a folder on your computer.
5. After verifying that the images were successfully transferred, return the memory card to your camera.

For Macintosh computers:

1. Insert your camera's memory card into the memory card reader (or into your computer's memory card slot).
2. Either the HP Photosmart Software, Image Capture, or iPhoto starts automatically and guides you through the process of transferring images.

If no application starts automatically or if you want to copy the images manually, look on the desktop for the disk drive icon for the memory card, then copy the images to your local hard drive. For more information about how to copy files, visit Mac help.

Printing images from the camera

You can connect the camera using the dock to any PictBridge-certified printer to print still images and frames saved from a video clip (see *Saving frames from video clips on page 27*). For information about printing panoramas directly to a printer, see *Printing panoramas from the camera*



on page 37.

1. Check that the printer is turned on, there is paper in the printer, and there are no printer error messages.
2. Verify that the camera's **USB Configuration** is set to **Digital Camera** (see **USB Configuration** under *Using the Setup Menu* on page 41).
3. Connect the dock and printer using the USB cable that came with your camera.
4. Place the camera in the dock and turn on the camera.
5. When the camera is connected to the printer, the **Print Setup Menu** displays on the camera.
 - To change the set of images you want to print, press / , then follow the on-screen instructions.
 - To change other settings, use / on the camera to select a menu option, then use / on the camera to change the setting.
6. Press to begin printing.

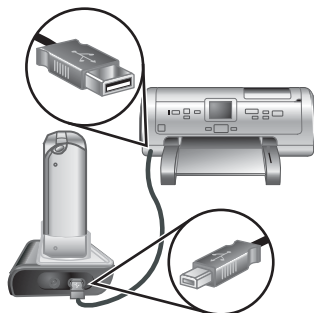

Note If you connect the camera to a non-HP printer and encounter problems with printing, contact your printer manufacturer. HP does not provide customer support for non-HP printers.

Printing panoramas from the camera

You can print panoramas stitched on the camera (see *Stitching panoramas* on page 29) directly to PictBridge-certified HP printers capable of printing panoramas on 10 x 30 cm (4 x 12 in) paper. You can also print portions of still images as panoramas.

1. Follow Steps 1 to 4 under *Printing images from the camera* on page 36, verifying that you have panorama paper in the printer.
2. When the **Print Setup Menu** displays on the camera, use / to select an option in **Images** or press / and follow the on-camera instructions to select a set of images.
3. In the **Print Setup Menu**, highlight **Print Size:**, use / to select **Panorama**, then press .
4. In the **Panorama Printing Menu**, highlight an option.
 - **Print as Shown**—Prints the area shown within the green box.
 - **Select Crop Area**—Allows you to adjust the portion of the selected image to print. To select the area, press , use , , , , and to position the green box over the area, then press to return to the **Panorama Printing Menu**.
 - **Skip This Image**—Proceeds to the next image without printing the image displayed.
 - **Cancel**—Exits the **Panorama Printing Menu**, cancels all pending and in-progress print jobs, and returns to the **Print Setup Menu**.
5. When you are done printing, remove the camera from the dock.

6 Using HP Photosmart Express

With **HP Photosmart Express**, you can select still images in your camera to print automatically (see *Selecting individual images for printing on page 39*) or to purchase online (see *Buying prints online on page 40*) the next time you connect the camera to your computer or printer. You can also customize the **Photosmart Express Menu** to include e-mail addresses, group distribution lists, online albums, or other online services that you specify. To customize the **Photosmart Express Menu**:

1. Set up your custom destinations on your camera (see *Setting up online destinations in the camera on page 38*).
2. Select images in your camera to send to online destinations (see *Sending individual images to online destinations on page 39* and *Sending all images to a printer or online destinations on page 40*).

You must have the HP Photosmart Software, either HP Photosmart Premier (Windows) or HP Photosmart Mac (Macintosh), on your computer to use some features in the **Photosmart Express Menu**. For information about this software, see *About the HP Photosmart Software on page 9*.



Note Available online services vary by country or region. Visit www.hp.com/go/sharing.

Using the Photosmart Express Menu

To display the **Photosmart Express Menu**, press . To select a menu option, use to highlight a selection, then press .



For on-camera information about an option, use to highlight **? Help Menu**, use to highlight a topic, then press .

	Print —Allows you to select images and specify number of copies to print. See <i>Selecting individual images for printing on page 39</i> .
	Buy Prints Online —Specifies images to request from an online printing service. See <i>Buying prints online on page 40</i> .
	Share All Images —Allows you to share all images on the camera to a selected destination. See <i>Sending all images to a printer or online destinations on page 40</i> .
	Share Menu Setup —Adds share destinations. See <i>Setting up online destinations in the camera on page 38</i> .

Setting up online destinations in the camera



You can specify up to 34 destinations of your choice (such as individual e-mail addresses or group distribution lists) in the **Photosmart Express Menu**.

1. Verify that your computer is connected to the Internet.
2. Turn on the camera, then press .

3. Highlight  **Share Menu Setup...**, then press $\frac{\text{Menu}}{\text{OK}}$. Connect the camera to your computer via the dock. Follow the instructions in the **Share** dialog box to set up destinations in your camera.
4. Disconnect the camera from the computer, then press  to verify that the new destinations are now in the camera.



Sending individual images to online destinations

1. Turn on the camera, then press .
2. Use $\blacktriangle/\blacktriangledown$ to highlight the first destination.
3. Use $\blacktriangleleft/\blacktriangleright$ to select a still image that you want to send, then press $\frac{\text{Menu}}{\text{OK}}$ to select it. A \checkmark appears over the destination in the **Photosmart Express Menu**. To deselect the destination, press $\frac{\text{Menu}}{\text{OK}}$ again.
4. Use $\blacktriangle/\blacktriangledown$ to highlight the next destination, then press $\frac{\text{Menu}}{\text{OK}}$. Repeat Step 3 to continue selecting images to send.
5. To exit the **Photosmart Express Menu**, press  / .
6. Connect the camera to your computer via the dock. The images are automatically sent to their destinations.



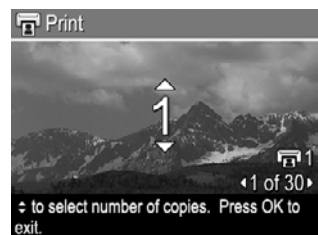

Selecting individual images for printing

1. Turn on the camera, then press .
2. Use $\blacktriangle/\blacktriangledown$ to highlight  **Print**.
3. Use $\blacktriangleleft/\blacktriangleright$ to display an image you want to mark for printing, then press $\frac{\text{Menu}}{\text{OK}}$ to display the **Print** sub-menu.
4. Use $\blacktriangle/\blacktriangledown$ to specify the number of copies to print (up to 99), then press $\frac{\text{Menu}}{\text{OK}}$. To deselect **Print**, select **Print** again, set the number of copies to **0**, then press $\frac{\text{Menu}}{\text{OK}}$.
5. To select additional images to mark for printing, use $\blacktriangleleft/\blacktriangleright$ to display an image, press $\frac{\text{Menu}}{\text{OK}}$, and repeat Step 4.
6. To exit the **Photosmart Express Menu**, press  / .
7. Connect the camera to a PictBridge-certified printer via the dock. The images you selected are automatically printed.



Sending all images to a printer or online destinations



1. Turn on the camera, then press .
2. Use $\blacktriangle/\blacktriangledown$ to highlight  **Share All Images...**, then press $\frac{\text{Menu}}{\text{OK}}$.
3. Use $\blacktriangle/\blacktriangledown$ to highlight the destination to which you want to send all the images, then press $\frac{\text{Menu}}{\text{OK}}$.
 - a. If you selected **Print**, the **Print All Images** sub-menu appears. Use $\blacktriangle/\blacktriangledown$ to specify the number of copies to print, then press $\frac{\text{Menu}}{\text{OK}}$. To deselect **Print**, select **Print** again in the **Share All Images** sub-menu, set the number of copies to **0**, then press $\frac{\text{Menu}}{\text{OK}}$.
 - b. If you selected any other destination, a \checkmark appears over that destination in the **Share All Images** sub-menu. To deselect the destination, press $\frac{\text{Menu}}{\text{OK}}$.
4. Repeat Step 3 to select additional destinations.
5. To exit the **Photosmart Express Menu**, press .
6. Connect the camera to your computer via the dock. The images are automatically sent to their respective destinations.



Note If you selected **Print** as a destination, you can also connect the camera directly to a PictBridge-certified printer (see [Printing images from the camera on page 36](#)).



Buying prints online

You can select images you want as prints and order them online.









1. Verify that your computer is connected to the Internet.
2. Turn on the camera, then press .
3. Use $\blacktriangle/\blacktriangledown$ to highlight  **Buy Prints Online**.
4. For each image you want to order as a print, use $\blacktriangleleft/\blacktriangleright$ to display the image, then press $\frac{\text{Menu}}{\text{OK}}$. A \checkmark appears over **Buy Prints Online** in the **Photosmart Express Menu**. To deselect the image, press $\frac{\text{Menu}}{\text{OK}}$ again.
5. Turn off your camera, connect the camera to your computer via the dock, then turn on your camera. Follow the instructions in the **Buy Prints Online** dialog box to purchase prints.
6. Disconnect the camera from the computer.

7 Using the Setup Menu





The **Setup Menu** allows you to set preferences for the camera's behavior.

1. While in **Live View** or **Playback**, press $\frac{\text{Menu}}{\text{OK}}$, then use $\blacktriangleleft \blacktriangleright$ to highlight .
2. Use $\blacktriangle \blacktriangledown$ to highlight a menu option, then press $\frac{\text{Menu}}{\text{OK}}$ to display the menu option's sub-menu.
3. Use $\blacktriangle \blacktriangledown$ to highlight a setting, then press $\frac{\text{Menu}}{\text{OK}}$.
4. To exit the **Setup Menu**, press  / .

Settings you specify remain until you change them.

	Display Brightness —Adjusts the brightness of the Image Display. <ul style="list-style-type: none">● Low—For extending battery life.● Medium (Default)—For normal viewing conditions.● High—For very bright lighting conditions.
	Sounds Volume —Adjusts the speaker volume for camera sounds (such as button presses and shutter clicks) and recorded audio. Off, Low (Default), High .
	Focus Assist Light —Enables the focus assist light used in low-light situations. You may want to turn off this feature when you do not want to distract the subject of your picture. Auto (Default), Off .
	Display Timeout —Specifies the time after which the Image Display turns off if you do not press a button. Never, 15, 30, 45 (Default), 60 seconds .
	Instant Review —Adjusts the time an image or video clip is displayed in Instant Review . Off, 1, 2 (Default), and 4 seconds .
	Digital Zoom —Enables or disables digital zoom. On (Default), Off .
	Date & Time —Sets the date and time. See Set the date and time on page 8 .
	USB Configuration —Specifies how a computer recognizes the camera. See Connecting to the computer on page 36 . <ul style="list-style-type: none">● Digital Camera (Default)—Recognizes the camera as a digital camera using PTP (Picture Transfer Protocol).● Disk Drive—Recognizes the camera as a disk drive using MSDC (Mass Storage Device Class).

(continued)

	<p>TV Configuration—Sets the video signal format for displaying camera images on a TV.</p> <ul style="list-style-type: none">● NTSC—Used primarily in North America, parts of South America, Japan, Korea, and Taiwan.● PAL—Used primarily in Europe, Uruguay, Paraguay, Argentina, and parts of Asia.
	<p> (Language)—Sets the language. See Choose the language on page 8.</p>
	<p>Reset Settings—Resets camera to the factory default settings.</p> <ul style="list-style-type: none">● Cancel—Exits the menu without resetting any of the settings.● Yes—Resets all camera settings to their defaults (except Date & Time, Language, TV Configuration, and USB Configuration).

8 Troubleshooting

Use this section to find information on:

- Resetting the camera (see [Resetting the camera on page 43](#))
- Possible problems and solutions (see [Problems and solutions on page 43](#))

Resetting the camera

If your camera does not respond when you press buttons, reset the camera.

1. Turn off the camera.
2. Remove the memory card and battery.
3. Press the straightened end of a paper clip into the **Reset** switch (the small hole located by the battery slot, as shown), hold the switch down for 3-6 seconds, then release.
4. Reinstall the battery and close the Battery/Memory card door.
5. Verify that the camera works without an optional memory card, then reinstall the card.



Resetting the camera returns all settings to their factory defaults. Any images or video clips stored in memory are retained.

Problems and solutions

Use this information to find solutions to common issues you may have using your camera.

The camera does not turn on.

- Install a new or recharged battery, ensuring that the battery is inserted correctly (see [Install the battery on page 7](#)) and that you are using a rechargeable HP Photosmart R07 Lithium Ion battery for HP Photosmart R-series cameras (L1812A/L1812B).
- Ensure that the HP AC power adapter is connected to the camera through the dock and is plugged into a working electrical outlet. Ensure that the HP AC power adapter is not damaged or defective.
- Reset the camera (see [Resetting the camera on page 43](#)).
- Ensure that the memory card is the proper type (see [Storage on page 55](#)). If so, remove the memory card and turn on the camera; if the camera turns on, format the memory card (see [Install and format an optional memory card on page 8](#)). If the camera still does not turn on, format the memory card using a memory card reader, or replace the memory card.

The battery gauge goes up and down frequently.

See [Power indicators on page 51](#).

I have to recharge the Lithium Ion battery frequently.

- See [Extending battery life on page 50](#).
- A battery that is new or has not been charged recently must be recharged to reach full capacity.
- If you have not used the battery for two months or longer, recharge it.

The Lithium Ion battery will not charge.

- Try charging it again after it has drained awhile.
- Use only the approved HP AC power adapter.
- If charging the battery in the HP quick recharger or the spare battery charging bay of an optional HP Photosmart dock does not work, replace the battery.

The camera does not turn on when I connect to AC power, then disconnect, then reconnect.

- Insert a battery into the camera.
- Reset the camera (see [Resetting the camera on page 43](#)).
- The AC power adapter could be malfunctioning. Try connecting to a different compatible AC power adapter.
- Try plugging the AC power adapter into a different electrical outlet.

The camera does not respond when I press a button.

- Turn on the camera.
- Most of the camera buttons do not respond when the camera is connected to a computer through the dock.
- Replace or recharge the battery.
- Reset the camera (see [Resetting the camera on page 43](#)).
- Check to see if the memory card is defective. If so, replace the memory card.
- Format the internal memory and/or the memory card (see [Install and format an optional memory card on page 8](#)).

The camera does not take a picture when I press the Shutter button.







- Press the **Shutter** button all the way down.
- The memory card or internal memory may be full. Transfer images from the camera to your computer, then format the internal memory or the memory card (see [Install and format an optional memory card on page 8](#)). Or replace the card with a new one.
- The camera may be processing. Wait a few seconds for the camera to finish processing the last image before taking another picture.

The Image Display is not working.

- The Image Display may have timed out. Press any camera button to wake up the camera.
- Replace or recharge the battery. If the Image Display does not turn on, remove the battery and connect to AC power via the dock. If the Image Display still does not turn on, reset the camera (see [Resetting the camera on page 43](#)).

My image is blurry.

- Use **Focus Lock** (see [Using Focus Lock on page 13](#)).
- Use a tripod to hold the camera steady, or improve lighting conditions.

- Set the camera to  **Macro**,  **Auto Macro**, **Normal**, or  **Infinity** focus and try taking the picture again (see *Using the focus range settings* on page 14).
- Set the flash to  **Auto Flash** or  **Flash On** and set the shooting mode to  **Action**.
- Check **Image Advice** for specific tips (see **Image Advice** under *Using the Playback Menu* on page 27).

My image is too bright.

- Turn the flash off (see *Setting the flash* on page 16).
- Move back from the subject and use zoom.
- Adjust **Exposure Compensation** (see **Exposure Compensation** under *Using the Capture Menu* on page 20).
- Use **Bracketing** for exposure (see **Bracketing** under *Using the Capture Menu* on page 20).
- Check **Image Advice** for specific tips (see **Image Advice** under *Using the Playback Menu* on page 27).

My image is too dark.

- Wait for natural lighting conditions to improve, use the flash (see *Setting the flash* on page 16) or add indirect lighting.
- Adjust **Exposure Compensation** (see **Exposure Compensation** under *Using the Capture Menu* on page 20).
- Use **Bracketing** for exposure (see **Bracketing** under *Using the Capture Menu* on page 20).
- Use **Adaptive Lighting** (see **Adaptive Lighting** under *Using the Capture Menu* on page 20).
- Use the **Spot** setting for **AE Metering** (see **AE Metering** under *Using the Capture Menu* on page 20).
- Check **Image Advice** for specific tips (see **Image Advice** under *Using the Playback Menu* on page 27).

My image is grainy.

- Use a lower **ISO Speed** setting (see **ISO Speed** under *Using the Capture Menu* on page 20).
- Add indirect lighting, use the flash (see *Setting the flash* on page 16), or wait for natural lighting conditions to improve.
- If the camera is warm, the effect will diminish as the camera cools. For best image quality, avoid storing the camera in very hot locations.
- Use **Image Advice** (see **Image Advice** under *Using the Playback Menu* on page 27).

Images are missing on my camera.

Remove the memory card and see if the images are stored in internal memory.

The Power light is on but the Image Display is off, or the camera seems stuck and won't operate.

- Press **Live View/Playback**  /  to reactivate the Image Display.
- Reset the camera (see *Resetting the camera* on page 43).

The camera responds sluggishly when trying to review images.

See [Storage on page 55](#) and [Memory capacity on page 56](#) for tips about memory cards.

Video recording terminates abruptly. The video is saved successfully, but it is shorter than expected.

- Choose a lower resolution/compression combination for the video (see **Video Quality** under [Using the Capture Menu on page 20](#)).
- Replace your memory card with a faster card. Look for cards marked High Performance, Pro, Ultra, or High Speed.

Video recording terminates abruptly and the video will not play back.

Reformat the card (see [Install and format an optional memory card on page 8](#)).

The camera gets warm (or even hot) to the touch.

This is normal. However, if anything seems out of the ordinary, turn off the camera, remove it from the dock, and allow the camera to cool. Then examine the camera and the battery for signs of possible damage.

For best image quality, turn off the camera when not using. Always store the camera in a cool place.

My camera stalls when establishing a connection to the computer.

- Ensure that the USB cable is properly connected to the camera dock and computer.
- Try connecting the USB cable to another USB port on the computer.
- Turn the camera off, then on again. If that does not fix the problem, reset the camera (see [Resetting the camera on page 43](#)).
- If the problem persists, contact HP Support (see [Product support on page 48](#)).

I cannot transfer images from the camera to my computer.

- Either install the HP Photosmart Software (see [Install the software on page 9](#)), or see [Transferring images without HP Photosmart Software on page 35](#).
- Set your camera to act as a **Disk Drive** (see [Connecting to the computer on page 36](#)).

I get an error message when transferring images to my computer.

A power surge or electrostatic discharge may have affected the camera. Close the HP Photosmart Transfer Software, remove the camera from the dock, and reset the camera (see [Resetting the camera on page 43](#)). Then restart the image transfer process (see [Transferring images with HP Photosmart Software on page 35](#)).

My camera shuts down unexpectedly, or displays a “Bad Data Access Error” message on the Image Display.

- A power surge or electrostatic discharge may have affected the camera. Remove the battery and reset the camera (see [Resetting the camera on page 43](#)). Then reinstall the battery and turn on the camera.
- If that does not work, try replacing the battery.

I am having a problem installing or using the HP Photosmart Software.

- Make sure your computer meets the minimum system requirements as listed on your camera packaging.
- Refer to the HP Customer Care website: www.hp.com/support.

How can I get professional-quality prints if I don't have a photo printer?

Use the **Buy Prints Online** feature on the **Photosmart Express Menu** (see *Buying prints online* on page 40).

9 Product support

Use this section to find support information for your digital camera, including links to helpful websites and an overview of the support process.

Helpful websites

Camera tips, product registration, newsletter subscriptions, driver and software updates, purchase HP supplies and accessories	www.hp.com www.hp.com/photosmart (English only)
Customers with disabilities	www.hp.com/hpinfo/community/accessibility (English only)
HP Customer Care, driver and software updates, support information	www.hp.com/support

Getting assistance

To get the best from your HP product, consult the following standard HP support offerings:

1. Consult the product documentation.
 - Review *Troubleshooting on page 43* in this document.
 - Review the electronic Help section within the software.
 - Refer to the camera's Help screens.
2. Visit HP online support at www.hp.com/support, or contact the store where you purchased this camera. HP online support is available to all HP customers. HP online support is the fastest source of up-to-date product information and expert assistance, including:
 - Fast e-mail access to qualified online support specialists.
 - Software and driver updates for your camera.
 - Valuable product and troubleshooting information for technical issues.
 - Proactive product updates, support alerts, and HP newsletters (available when you register your camera).
3. HP support by phone. Support options and fees vary by product, country, and language. For a list of support conditions and phone numbers, visit www.hp.com/support.
4. Post-warranty period. After the limited warranty period, help is available online at www.hp.com/support.

5. Extending or upgrading your warranty. If you would like to extend or upgrade your camera's warranty, please contact the store where you bought the camera or check the HP Care Pack offers at www.hp.com/support.
6. If you already purchased an HP Care Pack Service, please check the support conditions on your contract.

A Managing batteries

Your camera uses a rechargeable HP Photosmart R07 Lithium Ion battery (L1812A/L1812B).

Top points about batteries



Always insert the battery in the camera correctly (see [Install the battery on page 7](#)). If the battery is inserted improperly, the compartment door may close but the camera will not operate.

- New rechargeable Lithium Ion batteries are shipped partially charged. Fully charge them before first use.
- If you do not intend to use your camera for more than two months, leave the camera connected to the HP AC adapter. The camera will top off the battery periodically to ensure that the camera is always ready for use.
- A rechargeable Lithium Ion battery can be left in the camera or optional dock or quick recharger for any period of time without harm.
- If a rechargeable Lithium Ion battery has not been used for more than two months, recharge it before using it again. Fully recharge Lithium Ion batteries every six months to a year to prolong their useful life.
- The performance of Lithium Ion batteries degrades over time, especially if stored and used at high temperatures. If battery life is unacceptably short, replace the battery.
- The performance of Lithium Ion batteries will decrease as the temperature drops. To improve battery performance, keep the camera or batteries stored in a warm inside pocket when in a cold environment.

Extending battery life

To conserve battery power, the Image Display turns off after 45 seconds by default. Pressing any button wakes up the camera. After five minutes of inactivity, the camera turns off.

To further extend battery life:

- Set **Display Brightness** to **Low** (see **Display Brightness** under [Using the Setup Menu on page 41](#)).
- Change the **Display Timeout** value to a shorter interval (see **Display Timeout** under [Using the Setup Menu on page 41](#)).
- Set your camera to **Auto Flash** (see **Auto Flash** under [Setting the flash on page 16](#)).
- Use optical zoom sparingly.
- If you are turning on the camera only to view images, hold down  /  while turning on the camera to start in **Playback** without extending the lens.
- Connect the camera to the HP AC power adapter via the dock when you transfer or print.







Safety precautions for using batteries

- Do not place the battery in fire or heat the battery. Always store charged batteries in a cool location.
- Do not connect the positive and negative terminals of the battery to each other with any metal object.
- Do not carry or store the battery with metal objects. Do not drop the battery into a change-filled pocket.
- Do not pierce the battery or subject it to strong impacts or shocks.
- Do not solder directly onto the battery.
- Do not allow the battery to get wet.
- Do not disassemble or modify the battery.

- Immediately discontinue use of the battery if, while using, charging, or storing the battery, the battery emits an unusual smell, feels excessively hot (note that it is normal for the battery to feel warm), changes color or shape, or appears abnormal in any other way.
- In the event the battery leaks and the fluid gets into one's eye, do not rub the eye. Rinse well with water and immediately seek medical care. If left untreated, the battery fluid could cause damage to the eye.

Power indicators

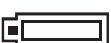
The power indicators are most accurate after a few minutes of use. The following table explains the meaning of these indicators.

Icon	Description
	Battery has more than 70 percent energy remaining.
	Battery has 30 to 70 percent energy remaining.
	Battery has 10 to 30 percent energy remaining.
	Battery level is low. Live View is disabled but you can still review images in Playback and use the menus.
 Blinking	Battery is depleted. Camera will power down.
	Camera is operating on AC power.
Animated battery filling up	Camera is operating on AC power and is charging the battery.
	Camera has successfully completed battery charging and is operating on AC power.



Note If the camera is without a battery for a prolonged period, the clock may be reset and you may be prompted to update it the next time you power on the camera.

Number of shots per battery type

The following table shows the minimum, maximum, and average number of shots that may be obtained using the rechargeable HP Photosmart R07 Lithium Ion battery.

Number of Shots			
Minimum	Maximum	Average	CIPA
110	200	165	200

For Minimum, Maximum, and Average numbers, four pictures are taken per session with at least a 5 minute break between sessions. In addition:

- The minimum number of shots is obtained with extensive use of **Live View** (30 seconds per picture), **Playback** (15 seconds per picture), and **Flash On**. Optical zoom (both directions) is used on 75% of the shots.
- The maximum number of shots is obtained with minimal use of **Live View** (10 seconds per picture) and **Playback** (4 seconds per picture). Flash and optical zoom (both directions) are used on 25% of the shots.
- The average number of shots is obtained with **Live View** used for 15 seconds per picture and **Playback** used for 8 seconds per picture. Flash and optical zoom (both directions) are used on 50% of the shots.
- The CIPA number is obtained using the standards established by the Camera and Imaging Products Association.

Recharging the Lithium Ion battery

You can recharge the HP Photosmart R07 Lithium Ion battery when the camera is in the dock using the AC adapter or with the optional quick recharger. You can also charge the battery in an optional HP Photosmart dock that has a battery bay.

The following table shows the average recharge time for a fully discharged battery, based on recharge location.

Charge location	Average charge time	Signals
In camera connected to the HP AC power adapter through the dock	2–3 hours	Charging: Camera's battery charging light blinks and the animated battery icon is displayed. Charging complete: Camera's battery charging light turns on solid and the battery gauge changes to  on the Image Display.
In camera connected to the HP AC power adapter through an HP Photosmart dock	2–3 hours	Charging: Dock's camera battery charging light blinks. Charging complete: Dock's camera battery charging light turns on solid.
In battery bay of the HP Photosmart 6221 Premium Camera Dock	2–3 hours	Charging: Dock's battery bay light blinks. Charging complete: Dock's battery bay light turns on solid.
In an HP Photosmart R-Series quick recharger	1 hour	Charging: Quick recharger light is yellow. Charging complete: Quick recharger light is green.

Safety precautions for recharging batteries

You can recharge a Lithium Ion battery in the camera or purchase an optional dock with battery bay or a quick recharger. These devices may be warm while charging a Lithium Ion battery. This is normal. However, you should follow the safety precautions below.

- Do not charge any other battery than the HP Photosmart R07 Lithium Ion battery in the camera, dock, or quick recharger.
- Insert the Lithium Ion battery in the correct orientation.
- Use the camera, dock, or quick recharger in a dry location only.
- Do not charge a Lithium Ion battery in a hot location, such as in direct sunlight or near a fire.
- When recharging a Lithium Ion battery, do not cover the camera, dock, or quick recharger.

- Do not operate the camera, dock, or quick recharger if the Lithium Ion battery appears damaged.
- Do not disassemble the camera, dock, or quick recharger.
- Unplug the HP AC power adapter or quick recharger from the electrical outlet before cleaning the power adapter or quick recharger.
- After extensive use, the Lithium Ion battery may begin to swell. If it becomes difficult to insert the battery into or remove the battery from the camera, dock, or quick recharger, discontinue use of the battery and replace it with a new one. Please recycle the old battery.

B Specifications

Resolution	<p>Still pictures:</p> <ul style="list-style-type: none"> • 8.2MP (3312 by 2496) total pixel count • 8.1MP (3296 by 2480) effective pixel count <p>Video clips (VGA—640 by 480 total pixel count; QVGA—320 by 240 total pixel count):</p> <ul style="list-style-type: none"> • VGA ★★★ (Default)—24 frames/sec • VGA ★★—24 frames/sec • QVGA ★—24 frames/sec
Sensor	Diagonal 9.1 mm (1/1.8-type, 4:3 format) CCD
Color depth	42 bit (14 bits by 3 colors). 42 bit images are transformed into an optimized 24 bit image and stored in the JPEG format. This transformation results in no discernible change to color or detail in the stored image, and allows the image to be read by computers.
Lens	<p>Focal length:</p> <ul style="list-style-type: none"> • Wide—7.78 mm • Telephoto—22.06 mm • 35 mm equivalent—35 mm to 105 mm <p>F-number:</p> <ul style="list-style-type: none"> • Wide—f/2.8 to f/7.8 • Telephoto—f/5 to f/8.5
Viewfinder	None
Zoom	<ul style="list-style-type: none"> • 3x optical zoom with 10 positions between wide and telephoto • 8x digital zoom
Focus	<p>Focus settings: Normal Focus (Default), Macro, Auto Macro, Infinity, Manual Focus</p> <p>Normal Focus (Default):</p> <ul style="list-style-type: none"> • Wide—500 mm (19.7 in) to infinity • Telephoto—600 mm (23.6 in) to infinity <p>Macro—Wide, 120 mm to 1 m (4.7 in to 39.4 in)</p> <p>Auto Macro—Automatically shifts into Macro when the subject is too close in Normal focus</p> <p>Infinity—Focus is fixed at infinity</p> <p>Manual—Focus is user-adjustable</p>
Shutter speed	1/2000 to 16 seconds
Built-in flash	Yes, 6-second typical recharge time (8-second maximum recharge time at power-on)

(continued)

Flash working range	<ul style="list-style-type: none">• Zoom Position Wide—Maximum with ISO Speed set to Auto ISO: 4.75 m (15.6 ft)• Zoom Position Telephoto—Maximum with ISO Speed set to Auto ISO: 4.75 m (15.6 ft)• Uniformity—Corner intensity > 55% of Center intensity (Lux Seconds)
Image Display	7.62 cm (3.0 in) color LTPS TFT LCD with backlight; 230,400 pixels (960 by 240) total pixel count
Storage	<ul style="list-style-type: none">• 32MB internal flash memory.• Slot for memory card.• This camera supports standard and high speed, HP-branded Secure Digital (SD) memory cards, 8MB to 2GB.• A large number of files (over 300) does affect the time it takes for the camera to turn on.• The number of images or video clips that can be saved in memory depends on the Image Quality and Video Quality settings (see Memory capacity on page 56).
Compression format	<ul style="list-style-type: none">• JPEG (EXIF) for still images• EXIF2.2 for still images with embedded audio• MPEG1 for video clips
Interfaces	Dock connector—Foxlink FPA25420—HP, which connects to either: <ul style="list-style-type: none">• HP Photosmart 6220 camera dock (in-box with camera)• HP Photosmart 6221 premium camera dock
Standards	<ul style="list-style-type: none">• PTP• USB—MSDC and SIDC• JPEG• MPEG1• DPOF• EXIF• DCF• DPS
External body dimensions	Measurements with camera off and lens retracted (width, depth, height): <ul style="list-style-type: none">• 96 mm (W) by 25.6 mm (D) by 62 mm (H)• 3.78 in (W) by 1.00 in (D) by 2.44 in (H)
Weight	170 grams (5.99 ounces) without battery
Power	Typical power usage: 2.1 Watts (with Image Display on). 7.6 Watts peak power usage. Power sources include: <ul style="list-style-type: none">• One rechargeable HP Photosmart R07 Lithium Ion battery for HP Photosmart R-series cameras• HP AC power adapter (5 Vdc, 2000 mA, 10 W) with either the HP Photosmart 6220 dock (included) or (optional) HP Photosmart 6221 or 6222 dock
Temperature range	Operational 0° to 50° C (32° to 122° F) at 15% to 85% relative humidity

	Storage –30° to 65° C (–22° to 149° F) at 15% to 90% relative humidity
--	---

Memory capacity

Not all 32MB of internal memory is available for storing images, because some memory is used for internal camera operations. The actual file sizes and number of still images that can be stored in internal memory or on a memory card will vary depending on the content of each still image and the length of any associated audio clip.

Image quality

The following table lists the approximate number and average size of still images that can be stored in internal memory when the camera is set to different **Image Quality** settings (see **Image Quality** under *Using the Capture Menu on page 20*).

8MP ★★★	7 images (3.56MB each)
Normal (8MP ★★) (Default)	10 images (2.5MB each)
5MP ★★	22 images (1.21MB each)
2MP ★★	42 images (631KB each)
VGA ★★	145 images (184KB each)
Custom...	Number of images depends upon resolution and compression selections



Note The values shown are for images without audio clips. Sixty seconds of audio adds 330KB to the file size.

Video quality

The following table lists the approximate number of seconds of video clips that can be stored in internal memory when the camera is set to different **Video Quality** settings (see **Video Quality** under *Using the Capture Menu on page 20*).

Normal (VGA ★★★)— (Default) 24 frames/sec	35 seconds
VGA ★★— 24 frames/sec	69 seconds
QVGA ★— 24 frames/sec	134 seconds

Index

- A**
 - Action mode 17
 - Adaptive Lighting 21, 24
 - adding borders 32
 - AE Metering 22
 - Aperture Priority mode 18
 - apply artistic effects 31
 - arrow buttons 5
 - artistic effects 31
 - assistance 48
 - audio clips 11, 30
 - Auto Focus Area 22
 - Auto Macro setting 15
 - Auto mode 17
- B**
 - battery
 - charge 7
 - conserving 50
 - door 6
 - install 7
 - shots per 51
 - top points about use 50
 - Beach mode 17
 - blinking lights on camera 5, 6
 - borders 32
 - Bracketing 21
 - Burst setting 22, 24
- C**
 - camera
 - dimensions 55
 - parts 5, 6
 - reset 43
 - specifications 54
 - turn on/off 7
 - weight 55
 - Capture Menu 20
 - color depth 54
 - color of images 21, 23
 - colors 32
 - compression format 55
 - computer, connect to 35, 36
 - Contrast 23
- D**
 - Date & Time 8, 41
- Date & Time Imprint** 23
- deleting images 5, 28
- Design Gallery 31
- digital zoom 16, 41
- dimensions 55
- direct print 36
- Display Brightness 41
- Display Timeout 41
- dock 6
- Document mode 18
- E**
 - e-mail images 38
 - exposure 14, 18, 19
 - Exposure Compensation 21, 24
- F**
 - F-number 54
 - flash
 - red-eye removal 16, 17, 21
 - working range 55
 - Flash button 5
 - focal length 54
 - focus
 - auto focus 12
 - Auto Focus Area 22
 - brackets 12
 - focus lock 13
 - Manual Focus 15
 - optimizing 13
 - settings 14, 54
 - Focus Assist light 41
 - Focus button 5
 - format memory card 8
- G**
 - getting assistance 48
- H**
 - HP Photosmart Express 38, 40
 - HP Photosmart Software 9, 10
- I**
 - Image Display 6
 - Image Info 28
- Image Quality** 21, 56
- images
 - Contrast 23
 - Date & Time Imprint 23
 - deleting 28
 - Image Quality 21, 56
 - magnifying 27
 - number remaining 11
 - Panorama mode 18
 - per battery 51
 - sending 39, 40
 - Sharpness 23
 - shooting modes 17
 - transfer to computer 35
 - White Balance 22
- Infinity focus 15
- install memory card 8
- install software 9
- Instant Review 12, 19, 24, 41
- interfaces 55
- internal memory 11, 56
- ISO Speed 22, 25
- L**
 - Landscape mode 17
 - Language 8, 42
 - LEDs 5, 6
 - lights on camera 5, 6
 - Lithium Ion battery 50, 52
 - Live View/Playback button 5
- M**
 - Macro focus 13, 15
 - Magnify control 5
 - magnifying images 27
 - Manual focus 15
 - Manual mode 18, 19
 - memory
 - capacity 56
 - card 11
 - card door 6
 - memory card 8, 55
 - Menu/OK button 5
 - menus
 - Capture 20
 - Design Gallery 31
 - Photosmart Express 38
 - Playback 27

Setup 41
microphone 6
modifying colors 32
Move Images to Card 28
My Mode 18, 19, 20

N

Night Portrait mode 17
Night Scenery mode 17
Normal Focus 13, 15
number of
 pictures remaining 11
 still images 56

O

on/off 7
ON/OFF button 5
online
 destinations 38
 print buying 40
optical zoom 15

P

Panorama mode 17, 18, 29
parts of camera 5, 6
Photosmart Express Menu 38,
 38, 39, 40
pictures 11, 23
Playback 26
Playback Menu 27
Portrait mode 17
power
 indicators 51
 light 5
 ON/OFF button 5
 usage 55
preview Panorama 29
print images 36, 38
prints, buy online 40
problems and solutions 43
product support 48

R

range, focus settings 14
record
 audio clips 30
 video clips 12
red-eye removal 17, 21
redeye removal 33
Region 8
remaining pictures count 11
removing red eyes 21, 33
reset camera 43

Reset Settings 42
resolution 54
reviewing images 26

S

safety precautions for
 batteries 50, 52
Saturation 23
Saved Settings, My Mode 20
selecting images for
 destinations 39, 40
Self-Timer
 light 6
 setting 21, 23
sending individual images 39
set date and time 8
setting up destinations 38
settings reset 42
Setup Menu 41
Share button 5
share pictures 38
Sharpness 23
shooting mode 17
Shutter button 5, 12
Shutter Priority mode 18
shutter speed 18, 19, 54
slideshow 29
Snow mode 18
software install 9
solving problems 43
sounds of camera 41
Sounds Volume 41
space remaining in memory 11
specifications 54
Stitch Panorama 29
storage 55
Sunset mode 18
support process 48

T

Theatre mode 17
Thumbnails 27
Thumbnails control 5
Time & Date 8, 41
transfer images 35
troubleshooting 43
turn on/off power 7
TV Configuration 42

U

USB configuration 36, 41

V

Video button 5

video clips 12, 22, 56
Video Quality 22, 56
View Slideshow 29
viewing thumbnails 27

W

websites 48
weight 55
White Balance 22, 25

Z

zoom 15, 16, 54
Zoom lever 5