

HP StorageWorks

4000/6000/8000 Enterprise Virtual Array user guide

Part number: 5697-5846
Fourth edition: May 2006



Legal and notice information

© Copyright 2005-2006 Hewlett-Packard Development Company, L.P.

The information contained herein is subject to change without notice. The only warranties for HP products and services are set forth in the express warranty statements accompanying such products and services. Nothing herein should be construed as constituting an additional warranty. HP shall not be liable for technical or editorial errors or omissions contained herein.

Microsoft®, MS-DOS®, MS Windows®, Windows®, Windows NT®, and Windows Server® are U.S. registered trademarks of Microsoft Corporation.

Java™ and Solaris™ are trademarks of Sun Microsystems, Inc.

Red Hat® and Red Hat® Enterprise Linux are registered trademarks of Red Hat, Inc.

Linux® is a registered trademark of Linus Torvalds.

Contents

About this guide	13
Overview	13
Intended audience	13
Related documentation	13
Document conventions and symbols	14
Rack stability	15
HP technical support	15
HP-authorized reseller	15
Helpful web sites	15
Subscribing to proactive updates	16
HP product documentation survey	16
1 Enterprise Virtual Array description	17
Introduction to the Enterprise Virtual Array	17
Features and enhancements	17
Ease of management	18
Data availability	18
Performance	18
Scalability	18
Operating system support	19
Fault management and diagnostics	19
EVA remote support tools	19
Storage system components	20
HP Command View EVA	20
Controller software	20
XCS features and functionality	20
Optional software licensing	21
Hardware	21
Physical layout of the storage system	21
Fibre Channel drive enclosure	22
Fibre Channel loop switches	22
HSV210-A and HSV200-A controllers	23
Racks	23
2 Enterprise Virtual Array startup	25
EVA8000 storage system connections	25
EVA6000 storage system connections	26
EVA4000 storage system connections	27
Direct connect	28
iSCSI connection configurations	29
Fabric connect iSCSI	29
Direct connect iSCSI	29
Procedures for getting started	30
Gathering information	30
Host information	30
Setting up a controller pair using the OCP	31
Entering the WWN	31
Entering the WWN checksum	32
Entering the storage system password	32
Installing HP Command View EVA	33

Installing optional EVA software licenses	33
3 Enterprise Virtual Array operation	35
Best practices	35
Operating tips and information	35
Reserving adequate free space	35
Using FATA disk drives	35
Failback preference setting for HSV controllers	35
Changing virtual disk failover/failback setting	38
Storage system shutdown and powerup	39
Shutting down the storage system	39
Powering up the storage system	39
Saving storage system configuration data	40
Adding disk drives to the storage system	42
Guidelines for adding disk drives	42
Creating disk groups	43
Adding a disk drive	44
Removing the drive blank	44
Changing the Device Addition Policy	45
Installing the disk drive	45
Checking status indicators	45
Adding the disk to a disk group	46
Handling fiber optic cables	46
4 Enterprise Virtual Array hardware components	49
Fibre Channel drive enclosures	49
Enclosure layout	49
I/O modules	50
I/O module status indicators	51
Fibre Optic Fibre Channel cables	53
Copper Fibre Channel cables	53
Fibre Channel disk drives	53
Disk drive status indicators	54
Disk drive status displays	54
Disk drive blank	55
Power supplies and blowers	55
Power supplies	56
Blowers	57
Drive enclosure EMU	57
Controls and displays	57
EMU functions	58
EMU monitoring functions	59
EMU displays	59
EMU indicator displays	60
Using the alphanumeric display	60
EMU push button status indicators	61
Audible alarm operations	61
Enabling the audible alarm	62
Muting or unmuting the audible alarm	63
Disabling the audible alarm	63
Enclosure number feature	64
Error Condition Reporting	66
Reporting group feature	69
Fibre Channel loop switches	71
30-10022-01 loop switch	72
30-10010-02 loop switch	71
Power-on self test (POST)	72
Reading the switch status indicators	72
Problem isolation	73

HSV controllers	74
High availability features	75
Operator control panel	75
Status indicators	76
Navigation buttons	77
Alphanumeric display	77
Displaying the OCP menu tree	77
Displaying system information	79
Displaying versions system information	79
Shutting down the system	80
Shutting the controller down	80
Restarting the system	81
Uninitializing the system	81
Password options	81
Changing a password	82
Clearing a password	82
Setting up a controller pair using the OCP	82
Power supplies	83
Blowers	83
Cache battery	84
HSV controller cabling	85
Racks	85
Rack configurations	85
Power distribution	85
PDUs	86
PDMs	87
Rack AC power distribution	88
Rack System/E power distribution components	89
Moving and stabilizing a rack	90

5 Customer replaceable units 93

Customer self repair (CSR)	93
Parts only warranty service	93
Best practices for replacing hardware components	94
Component replacement videos	94
Verifying component failure	94
Procuring the spare part	94
Replacing the failed component	97
Returning the defective part	97
Replacing the cache battery	97
Before you begin	98
Verifying component failure	98
Removing a battery	99
Installing a battery	99
Verifying proper operation	100
Replacing a controller blower	100
Before you begin	100
Verifying component failure	100
Removing a blower	101
Installing a blower	102
Verifying proper operation	102
Returning the failed component	102
Replacing the controller power supply	103
Before you begin	103
Verifying component failure	103
Removing a power supply	104
Installing a power supply	104
Verifying proper operation	105
Returning the failed component	105

Replacing a disk drive	105
Before you begin	105
Verifying component failure	105
Removing a disk	106
Changing the Device Addition Policy	107
Installing a disk drive	107
Verifying proper operation	107
Adding a disk to a disk group	108
Returning the failed component	108
Replacing the disk enclosure power supply/blower	108
Before you begin	108
Verifying component failure	109
Removing a blower	109
Installing a blower	110
Removing a power supply	110
Installing a power supply	111
Verifying proper operation	112
Returning the failed component	112

A Regulatory notices and specifications 113

Regulatory notices	113
Federal Communications Commission (FCC) notice	113
FCC Class A certification	113
Class A equipment	113
Class B equipment	114
Declaration of conformity for products marked with the FCC logo, United States only	114
Modifications	114
Cables	114
Laser device	114
Laser safety warnings	114
Compliance with CDRH regulations	115
Certification and classification information	115
Canadian notice (avis Canadien)	115
Class A equipment	115
Class B equipment	115
European union notice	115
Notice for France	116
WEEE Recycling Notices	116
English notice	116
Dutch notice	116
Czechoslovakian notice	116
Estonian notice	117
Finnish notice	117
French notice	117
German notice	117
Greek notice	118
Hungarian notice	118
Italian notice	118
Latvian notice	118
Lithuanian notice	119
Polish notice	119
Portuguese notice	119
Slovakian notice	119
Slovenian notice	120
Spanish notice	120
Swedish notice	120
Germany noise declaration	120
Japanese notice	121
Harmonics conformance (Japan)	121

Taiwanese notice	121
Japanese power cord notice	121
Country-specific certifications	121
Storage system specifications	122
Physical specifications	122
Environmental specifications	122
Power specifications	123

B EMU-generated condition reports 127

Condition report format	127
Correcting errors	128
Drive conditions	128
0.1.en.01 CRITICAL condition—Drive configuration or drive link rate	128
0.1.en.02 INFORMATION condition—Drive missing	129
0.1.en.03 INFORMATION condition—Drive software lock active	129
0.1.en.04 CRITICAL condition—Loop a drive link rate incorrect	130
0.1.en.05 CRITICAL condition—Loop b drive link rate incorrect	130
Power supply conditions	130
0.2.en.01 NONCRITICAL Condition—Power supply AC input missing	131
0.2.en.02 UNRECOVERABLE condition—Power supply missing	131
0.2.en.03 CRITICAL condition—Power supply load unbalanced	131
Blower conditions	132
0.3.en.01 NONCRITICAL condition—Blower speed	132
0.3.en.02 CRITICAL condition—Blower speed	132
0.3.en.03 UNRECOVERABLE condition—Blower failure	133
0.3.en.04 UNRECOVERABLE condition—Blower internal	133
0.3.en.05 NONCRITICAL condition—Blower missing	133
0.3.en.06 UNRECOVERABLE condition—No blowers installed	133
Temperature conditions	133
0.4.en.01 NONCRITICAL condition—High temperature	134
0.4.en.02 CRITICAL condition—High temperature	134
0.4.en.03 NONCRITICAL condition—Low temperature	135
0.4.en.04 CRITICAL condition—Low temperature	135
0.4.en.05 UNRECOVERABLE condition—High temperature	135
EMU conditions	136
Resetting the EMU	136
07.01.01 CRITICAL condition—EMU internal clock	136
07.01.02 UNRECOVERABLE condition—EMU interrupted	136
0.7.01.03 UNRECOVERABLE Condition—Power supply shutdown	137
0.7.01.04 INFORMATION condition—EMU internal data	137
0.7.01.05 UNRECOVERABLE condition—Backplane NVRAM	137
0.7.01.10 NONCRITICAL condition—NVRAM invalid read data	137
0.7.01.11 NONCRITICAL condition—EMU NVRAM write failure	137
0.7.01.12 NONCRITICAL condition—EMU cannot read NVRAM data	138
0.7.01.13 UNRECOVERABLE condition—EMU load failure	138
0.7.01.14 NONCRITICAL condition—EMU enclosure address	138
0.7.01.15 UNRECOVERABLE condition—EMU hardware failure	139
0.7.01.16 INFORMATION condition—EMU internal ESI data corrupted	139
0.7.01.17 UNRECOVERABLE condition—Power shutdown failure	139
0.7.01.18 UNRECOVERABLE condition—EMU hardware failure	139
0.7.01.19 UNRECOVERABLE condition—EMU ESI driver failure	140
Transceiver conditions	140
0.F.en.01 CRITICAL condition—Transceiver incompatibility	140
0.F.en.02 CRITICAL condition—Transceiver data signal lost	140
0.F.en.03 CRITICAL condition—Transceiver fibre channel drive enclosure bus fault	141
0.F.en.04 CRITICAL condition—Transceiver removed	141
0.F.en.05 CRITICAL condition—Invalid fibre channel character	141
Voltage sensor and current sensor conditions	141
1.2.en.01 NONCRITICAL condition—High voltage	142
1.2.en.02 CRITICAL condition—High voltage	142

1.2.en.03 NONCRITICAL condition—Low voltage	142
1.2.en.04 CRITICAL condition—Low voltage	142
1.3.en.01 NONCRITICAL condition—High current	142
1.3.en.02 CRITICAL condition—High current	142
Backplane conditions	143
8.2.01.10 NONCRITICAL condition—Backplane NVRAM read	143
8.2.01.11 NONCRITICAL condition—Backplane NVRAM write failure	143
8.2.01.12 NONCRITICAL condition—Backplane NVRAM read failure	143
8.2.01.13 NONCRITICAL condition—Backplane WWN is blank	143
I/O Module conditions	143
8.7.en.01 CRITICAL condition—I/O module unsupported	144
8.7.en.02 CRITICAL condition—I/O module communication	144
8.7.en.10 NONCRITICAL condition—I/O module NVRAM read	144
8.7.en.11 NONCRITICAL condition—I/O module NVRAM write	144
8.7.en.12 NONCRITICAL condition—I/O Module NVRAM read failure	145
8.7.en.13 NONCRITICAL condition—I/O module removed	145
Host conditions	145

C Controller fault management	147
Using HP Command View EVA	147
GUI termination event display	147
GUI event display	147
Fault management displays	148
Displaying Last Fault Information	148
Displaying Detailed Information	148
Interpreting fault management information	149

D Non-standard rack specifications	151
Rack specifications	151
Internal component envelope	151
EIA310-D standards	151
EVA cabinet measures and tolerances	152
Weights, dimensions and component CG measurements	152
Airflow and Recirculation	153
Component Airflow Requirements	153
Rack Airflow Requirements	153
Configuration Standards	153
Environmental and operating specifications	153
Power requirements	153
UPS Selection	155
Environmental specifications	157
Shock and vibration specifications	157

Glossary	159
---------------------------	------------

Index	175
------------------------	------------

Figures

1 Storage system hardware components	22
2 EVA8000 configuration	26
3 EVA6000 configuration	27
4 EVA4000 configuration	28
5 Location of the World Wide Name labels	32
6 Disk drive activity indicator	43
7 Sequential building of vertical disk groups	44
8 Removing the drive blank	44
9 Installing the disk drive	45
10 Disk drive status indicators	46
11 FC drive enclosure—front and rear views	50
12 I/O module	51
13 Input and output ports	51
14 Fibre Optic Fibre Channel cable	53
15 Copper Fibre Channel cable	53
16 Disk drive status indicators	54
17 Power supply and blower assembly components	56
18 EMU controls and displays	58
19 Enclosure numbering with enclosure ID expansion cables	65
20 Enclosure address bus components with enclosure ID expansion cables	66
21 Displaying error condition values	69
22 30-10022-01 loop switch status indicators	71
23 30-10010-02 loop switch status indicators	72
24 HSV210-A controller—rear view	74
25 HSV200-A controller—rear view	74
26 HSV controller—front view	75
27 Controller OCP	76
28 Power supplies	83
29 Blower	84
30 Cache batteries	84
31 60-Hz and 50-Hz wall receptacles	86
32 Dual PDU assembly	87
33 Rack PDM	88
34 Rack AC power distribution	89
35 Single rack configuration floor space requirements	90
36 Raising a leveler foot	91
37 Typical product label	95
38 Disk drive label	95
39 Battery status indicators	99
40 Removing a battery	99
41 Installing a battery	100
42 Blower status indicators	101
43 Removing a blower	102
44 Installing a blower	102
45 Power supply status indicator	104
46 Removing a power supply	104
47 Installing a power supply	105
48 Disk drive status indicators	106
49 Removing a disk drive	107
50 Installing a disk drive	107
51 Power supply/blower status indicator	109
52 Removing a blower	110
53 Installing a blower	110
54 Removing a power supply	111

55	Installing a power supply	112
56	Typical enclosure certification label	122
57	Power supply element numbering	131
58	Blower element numbering	132
59	Disconnecting AC power	139
60	Transceiver element numbering	140
61	I/O module element numbering	144
62	GUI termination event display	147
63	Typical HP Command View EVA Event display	148
64	Mounting space dimensions	151

Tables

1 Document conventions	14
2 Push button functions	31
3 Failback preference settings	36
4 Failback Settings by Operating System	38
5 Impact on virtual disk presentation when changing failover/failback setting	38
6 Operational I/O module status indicators	52
7 Non-operational I/O module status indicators	52
8 Disk drive status indicator descriptions	54
9 Operational disk drive status indications	55
10 Non-operational disk drive status indications	55
11 Power supply/blower status indicators	57
12 EMU monitoring functions	59
13 EMU status displays	59
14 EMU status indications	60
15 EMU display groups	61
16 Audible alarm sound patterns	62
17 Error condition reporting characteristics	67
18 30-10010-02 loop switch status indicators	72
19 30-10010-02 loop switch port status indicators	73
20 30-10010-02 loop switch basic troubleshooting	73
21 Controller status indicators	76
22 Controller port status indicators	77
23 Navigation button functions	77
24 Menu options within the OCP display	79
25 Shutdown methods	80
26 Power supply status indicators	83
27 Blower status indicators	84
28 Battery status indicators	85
29 Hardware component CSR support	96
30 Enterprise Virtual Array 4000/6000/8000 Product Dimensions, Weight and Clearance	122
31 Environmental specifications	123
32 Enterprise storage system AC input line voltages	123
33 Power Data (North America/Europe/Japan) maximum configuration	124
34 EVA4000 power specifications — 208 Volts	124
35 EVA4000 power specifications — 230 Volts	124
36 EVA6000 power specifications — 208 Volts	125
37 EVA6000 power specifications — 230 Volts	125
38 EVA8000 power specifications — 208 Volts	126
39 EVA8000 power specifications — 230 Volts	126
40 Assigned element type codes	128
41 Temperature sensor element numbering	134
42 Voltage and current sensor locations	142
43 Controller event text description file	149
44 Component data	152
45 208V Wattage and BTU/Hour	154
46 230V Wattage and BTU/Hour	154
47 100V Wattage and BTU/Hour	155
48 HP UPS models and capacities	155
49 UPS operating time limits	156
50 EVA 8000 UPS loading	156
51 EVA 6000 UPS loading	157
52 EVA 4000 UPS loading	157
53 Environmental specifications	157
54 Operating Shock/Vibration	158

About this guide

This user guide provides the following information:

- Description of the HP StorageWorks Enterprise Virtual Array family and its components.
- Starting your storage system.
- Operating your storage system.
- Regulations and specifications.
- EMU-generated error condition reports.
- HSV fault management concepts.
- Installing customer replaceable units.

This chapter contains the following sections:

- [Overview](#)
- [Document conventions and symbols](#)
- [Rack stability](#)
- [HP technical support](#)

Overview

This section contains the following topics:

- [Intended audience](#)
- [Related documentation](#)

Intended audience

This book is intended for use by Enterprise Virtual Array customers involved in the installation, operation, and management of EVA 4000/6000/8000 storage systems and who are experienced with the following:

- SANs and storage systems.
- Networking and virtual storage concepts.
- Enterprise Virtual Array products.

Related documentation

Additional product documentation is available from the following HP web site:

<http://www.hp.com/support/manuals>

Click **Storage Array Systems** under Storage, and then select the appropriate product under Enterprise Virtual Array Systems.

Document conventions and symbols

Table 1 Document conventions

Convention	Element
Medium blue text: Related documentation	Cross-reference links and e-mail addresses
Medium blue, underlined text (http://www.hp.com)	Web site addresses
Bold font	<ul style="list-style-type: none">• Key names• Text typed into a GUI element, such as into a box• GUI elements that are clicked or selected, such as menu and list items, buttons, and check boxes
<i>Italic font</i>	Text emphasis
Monospace font	<ul style="list-style-type: none">• File and directory names• System output• Code• Text typed at the command line
<i>Monospace, italic font</i>	<ul style="list-style-type: none">• Code variables• Command-line variables
Monospace, bold font	Emphasis of file and directory names, system output, code, and text typed at the command line

 **WARNING!**

Indicates that failure to follow directions could result in bodily harm or death.

 **CAUTION:**

Indicates that failure to follow directions could result in damage to equipment or data.

 **IMPORTANT:**

Provides clarifying information or specific instructions.

 **NOTE:**

Provides additional information.

 **TIP:**

Provides helpful hints and shortcuts.

Rack stability

⚠ WARNING!

To reduce the risk of personal injury or damage to equipment:

- Extend leveling jacks to the floor.
 - Ensure that the full weight of the rack rests on the leveling jacks.
 - Install stabilizing feet on the rack.
 - In multiple-rack installations, secure racks together.
 - Extend only one rack component at a time. Racks may become unstable if more than one component is extended.
-

HP technical support

Telephone numbers for worldwide technical support are listed on the HP support web site: <http://www.hp.com/support/>.

Collect the following information before calling:

- Technical support registration number (if applicable)
- Product serial numbers
- Product model names and numbers
- Applicable error messages
- Operating system type and revision level
- Detailed, specific questions

For continuous quality improvement, calls may be recorded or monitored.

HP strongly recommends that customers sign up online using the Subscriber's choice web site: <http://www.hp.com/go/e-updates>.

- Subscribing to this service provides you with e-mail updates on the latest product enhancements, newest versions of drivers, and firmware documentation updates as well as instant access to numerous other product resources.
- After signing up, you can quickly locate your products by selecting **Business support** and then **Storage** under Product Category.

HP-authorized reseller

For the name of your nearest HP-authorized reseller:

- In the United States, call 1-800-282-6672.
- Elsewhere, visit the HP web site: <http://www.hp.com>. Then click **Contact HP** to find locations and telephone numbers.

Helpful web sites

For other product information, see the following HP web sites:

- <http://www.hp.com>
- <http://www.hp.com/go/storage>
- <http://www.hp.com/support/>
- <http://www.docs.hp.com>

Subscribing to proactive updates

Receive support alerts (such as Customer Advisories), as well as updates on drivers, software, firmware, and customer replaceable components, proactively via email through HP Subscriber's Choice. Sign up for Subscriber's Choice at the following URL:

<http://www.hp.com/go/myadvisory>

HP product documentation survey

Are you the person who installs, maintains, or uses this HP storage product? If so, we would like to know more about your experience using the product documentation. If not, please pass this notice to the person who is responsible for these activities.

Our goal is to provide you with documentation that makes our storage hardware and software products easy to install, operate, and maintain. Your feedback is invaluable in letting us know how we can improve your experience with HP documentation.

Please take 10 minutes to visit the following web site and complete our online survey. This will provide us with valuable information that we will use to improve your experience in the future.

<http://www.hpwebgen.com/questions.cfm?id=4601&pass=3712>

Thank you for your time and your investment in HP storage products.

1 Enterprise Virtual Array description

This chapter provides an overview of Enterprise Virtual Array and its components. Topics to be covered include:

- [Introduction to the Enterprise Virtual Array](#)
- [New features and enhancements](#)
- [Storage system components](#)

Introduction to the Enterprise Virtual Array

The HP StorageWorks Enterprise Virtual Array family is a high performance, scaled capacity, on demand, "virtual" RAID storage system.

This storage system is designed for environments where improved storage use and scalability is critical. It meets application-specific demands for consistently high transaction I/O (input/output) and MB data rate performance, and provides seamless capacity expansion, instantaneous replication, and simplified storage administration.

The Enterprise Virtual Array (EVA) is available in multiple configurations—each optimized for general-purpose commercial environments and high-performance technical computing environments. The solutions include support for multivendor operating system platforms and stringent data center availability enhancements, such as multipathing and clustering.

This guide includes information for three Enterprise Virtual Array products: EVA8000, EVA6000, and EVA4000.

- EVA8000—available in multiple configurations ranging from the single-rack 2C2D configuration to the multi-rack 2C18D. The EVA8000-A includes two HSV210-A controllers and four Fibre Channel loop switches.
- EVA6000—available in configurations ranging from the 2C4D configuration to the 2C8D configuration. The EVA6000-A includes two HSV200-A controllers and two Fibre Channel loop switches.
- EVA4000—available in configurations ranging from the 2C1D configuration to the 2C4D configuration without loops switches. The EVA4000-A includes two HSV200-A controllers. Multiple EVA4000s can be installed in a single rack.

Refer to the *HP StorageWorks 4000/6000/8000 Enterprise Virtual Array hardware configuration guide* for more information about configurations. See "[Related documentation](#)" on page 13 for links to this document.

Features and enhancements

The Enterprise Virtual Array provides many features and enhancements which are detailed in the sections that follow.

- [Ease of management](#)
- [Data availability](#)
- [Performance](#)
- [Scalability](#)
- [Operating system support](#)
- [Fault management and diagnostics](#)

- EVA remote support tools

Ease of management

Easy-to-use storage management tools:

- Software tools that allow you to manage larger SAN configurations with more servers and more storage solutions
- HP-supplied disk drives conform to the enclosure-initiated Enclosure Services Interface (ESI)
- State-of-the-art controller software
- Completely integrated configurations with a single part number, plus disk drives and storage system software
- Support for integrated iSCSI EVA solution

Data availability

- Redundant hardware design and value—added software eliminate single points of failure from server to storage in clustered or single server configurations with multipathing.
- Full support for local and remote data replication using optional HP StorageWorks Business Copy EVA and HP StorageWorks Continuous Access EVA applications. More information on these products is available at the following web sites:
 - HP Business Copy EVA - <http://h18006.www1.hp.com/products/storage/software/bizcopyeva/index.html>
 - HP Continuous Access EVA - <http://h18006.www1.hp.com/products/storage/software/conaccesseva/index.html>
- Dual- and multi-node cluster support provided for host-level fault tolerance and high system availability.
- Support for active-active failover, allowing the use of industry popular multipathing solutions and native host bus adapters.

Performance

Outstanding self-tuning performance includes:

- 4 Gb transfer capability from the HSV controllers to the SAN. Support for 4 Gb host bus adapters and switches.
- Virtualization technology—Vraid, enables data to be distributed from 8 to 240 disks to increase disk spindle count far beyond traditional RAID sets. This virtualization method also optimizes storage for the best performance of a specific configuration and application. Enterprise Virtual Array eliminates tedious management functions to provide the best performance possible.
- Both online high-performance disk drives and FATA (Fibre Attached Technology Adapted) disk drives.
- State-of-the-art controller software that improves performance, increases capacity, and allows for easy dynamic storage expansion.

Scalability

The EVA8000 provides:

- Capability of addressing up to 200 TB
- Maximum capacity of 120 TB (using 500 GB drives)
- A maximum of 240 disk drives
- Support for 1024 virtual disks

The EVA6000 provides:

- Capability of addressing up to 80 TB

- Maximum capacity of 56 TB (using 500 GB drives)
- A maximum of 112 disk drives
- Support for 1024 virtual disks

The EVA4000 provides:

- Capability of addressing up to 80 TB
- Maximum capacity of 28 TB (using 500 GB drives)
- A maximum of 56 disk drives
- Support for 1024 virtual disks

All models support the following disk capacities:

- 300 GB FC disk drives
- 250 GB, 400 GB, and 500 GB FATA disk drives
- 146 GB FC disk drives
- 72 GB FC disk drives

For the most current information on supported disk drives, refer to the *HP StorageWorks 4000/6000/8000 Enterprise Virtual Array release notes*. See "[Related documentation](#)" on page 13 for links to this document.

Operating system support

- HP-UX
- Microsoft Windows 2003 Standard/Enterprise (32/64-bit) & Extended/DataCenter (64-bit)
- Microsoft windows 2000 Server & Advanced Server
- HP Open VMS
- HP Tru64 Unix
- Sun Solaris
- IBM AIX
- Linux
- VMware
- Novell NetWare

For the most current information on supported operating systems, refer to the appropriate connectivity documents. See "[Related documentation](#)" on page 13 for links to these documents.

Fault management and diagnostics

WEBES must be installed to ensure proper customer alerts for their EVA products.

WEBES can be used as part of the HP ISEE remote service offering. Or, for those customers who do not wish to have remote support, it can be configured to send a local notification (e-mail) to a customer-identified account only. The e-mail option is also available to the customer when ISEE is used.

WEBES is a powerful service tool that provides real-time diagnosis of hardware events ranging from single errors (or faults) to multiple event correlation and complex analysis. It is designed to send a notification only when an event or series of events has occurred that requires a service action.

A Service Tools CD is included with the HP Command View EVA package. However, it is always best to check the HP web site for the latest updates.

The latest WEBES kit can be downloaded from this URL: <http://h18000.www1.hp.com/support/svctools>

EVA remote support tools

As a no-charge option, HP will install ISEE remote service tool for any Enterprise Virtual Array under warranty or service support. This tool enables EVA self-monitoring and diagnosis. ISEE can significantly reduce the time required to isolate and correct problems. If desired, the tool can be configured to

transmit status information directly to an HP service center for proactive problem resolution. Contact your local HP Services department for details.

Storage system components

The Enterprise Virtual Array comprises three main components:

- Hardware—the physical components, such as disk drives, enclosures, controllers, and loop switches. These pieces are installed in a rack and connected to the SAN.
- HP StorageWorks Controller Software—manages operation of the storage system hardware and provides the communication link to HP Command View EVA.
- HP Command View EVA—management software that communicates with the controllers. Together, HP Command View EVA and the controllers control and monitor Enterprise Virtual Array storage systems.

These components work together to create an entire storage system solution. Management is accomplished by accessing HP Command View EVA through your browser.

HP Command View EVA

HP Command View EVA is the primary software application for managing the EVA. HP Command View EVA is used to perform the following administrative tasks.

- Creating virtual disk families, including selection of Vraid level, cache policy, and host presentation.
- Managing the presentation of Vraid drives to hosts.
- Managing and monitoring storage system hardware.
- Creating snapclones and snapshots of virtual disks.

An online help system is available within the interface, including page-level help.

Controller software

HP StorageWorks Virtual Controller Software (XCS) manages all aspects of storage system operation. XCS provides scalable capacity on-demand, improves performance, increases disk utilization efficiency, and allows for easy dynamic storage expansion. XCS is installed on the storage system and is also included in the XCS for HSV Controller software kit.

XCS features and functionality

- Support for up to 240 disk drives per controller pair
- Management of up to 1024 virtual disks, ranging in size from 1 GB to 2 TB per virtual disk, per disk pool
- Dynamic capacity expansion in 1 GB increments (requires operating system support)
- Virtual disk data load leveling
- Distributed sparing of disk capacity
- Supports Direct Attach connection to Windows servers without the need for SAN switches.
- Supports integrated iSCSI connectivity direct for Windows and Linux or through the SAN.
- Virtually capacity-free snapshot (Vsnap)
- Virtually Instantaneous Snapclone (VIS) and 3-phase Snapclones
- Dual redundant controller operation for increased fault tolerance
- Multi-path failover support
- Battery backup for cache memory
- Asynchronous disk swap (Hot Swap)
- Clustered server support
- Mirrored write-back cache support

- Read-ahead and adaptive read caching support
- Virtual RAID storage system (Vraid0, Vraid1, Vraid5)
- Non-disruptive software upgrade capability
- Supports connection of up to 256 hosts
- Multivendor platform support
- Controller password protection for configuration control
- Selective storage presentation
- SAN-based data zoning

Optional software licensing

HP Business Copy and HP StorageWorks Continuous Access require a separate license for each controller pair. Instructions for obtaining licenses are included with the software documentation.

Additional information about HP Business Copy and HP Continuous Access can be found online at <http://h18006.www1.hp.com/storage/software.html>.

Hardware

The Enterprise Virtual Array includes the following hardware components:

- Fibre Channel drive enclosure—Contains disk drives, power supplies, blowers, I/O modules, and an Environmental Monitoring Unit (EMU).
- Fibre Channel loop switches—Provides twelve-port central interconnect for Fibre Channel drive enclosure FC Arbitrated Loops. The loop switches are required only for EVA6000 and EVA8000 configurations with more than four disk enclosures.
- HSV controller—Manages all aspects of storage system operation, including communications between host systems and other devices. A pair of HSV controllers is included in Enterprise Virtual Array.
- Rack—A variety of free-standing racks are available.

Physical layout of the storage system

The basic physical components are shown in [Figure 1](#). The disk drives are installed in the disk enclosures, which connect to Fibre Channel loop switches, except on the EVA4000 which does not use switches. The controller pair also connects to the loop switches.

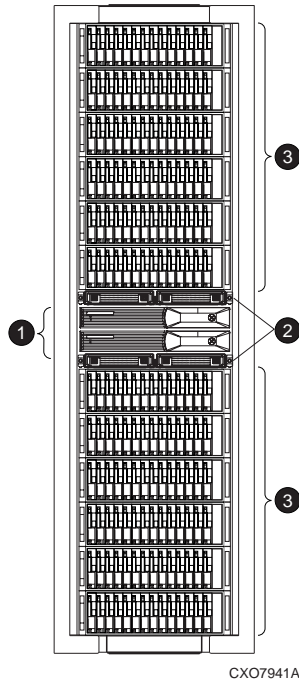

Figure 1 Storage system hardware components

- | | |
|---------------------|------------------|
| 1. Drive enclosures | 2. loop switches |
| 3. Controllers | |

The hardware components shown in [Figure 1](#) are discussed in the following sections and in [Storage System Hardware Components](#).

Fibre Channel drive enclosure

Each Fibre Channel drive enclosure includes the following features. For additional information, see [Fibre Channel drive enclosures](#).

- 3U enclosure
- Dual-redundant, active-to-active, 2-Gbps FC loops
- Fourteen bays for 1-inch FC disks
- Environmental Monitoring Unit (EMU)
- Dual 2-Gbps FC I/O modules—A and B loops
- Dual redundant 500-W power supplies and blowers
- Dual redundant blowers

For ease of management, the disk drives are referred to by their physical location, the drive bay number.

Fibre Channel loop switches

The loop switches act as a central point of interconnection and establishes a fault-tolerant physical loop topology between the controllers and the disk enclosures. The loop switches are required in any configuration with more than four disk enclosures. The EVA8000 uses four loop switches and the EVA6000 uses two switches to connect the drive enclosures to the controller pair.

The loop switches provide the following features. For detailed information on loop switches, see [Fibre Channel loop switches](#).

- 2.125-Gbps operating speed
- Twelve ports
- Half-width, 1U size

- System and port status indicators
- Universal power supply that operates between 100 to 250 VAC and 50 to 60 Hz

**NOTE:**

Each bezel covers two FC loop switches in a space of 1U.

HSV210-A and HSV200-A controllers

Two controllers are contained in each rack. Each controller is contained in a separate enclosure and provides the features listed below. For detailed information, see [HSV controllers](#).

**NOTE:**

The EVA4000/6000/8000 now uses controllers with 4 Gb host port capability. The 4 Gb controller can be distinguished from the earlier 2 Gb controllers by the “-A” suffix used on the controller bezel. The 4 Gb EVA4000/6000 controller is identified as the HSV200-A and the EVA8000 is identified as the HSV210-A.

- High-performance microprocessor
- An Operator Control Panel (OCP)
- Four 4-Gbps Fibre Channel-Switched fabric host ports (two host ports in HSV200-A controller)
- Four 2-Gbps Fibre Channel drive enclosure device ports (two device ports in HSV200-A controller)
 - Arranged in redundant pairs
 - Data load/performance balanced across a pair
 - Support for up to 240 disks with HSV210-A and 112 with HSV200-A
- 2-GB cache per controller, mirrored, with battery backup (1-GB cache in HSV200-A controller)
- 2-GBps FC cache mirroring ports with device port backups
- Dual power supplies

In addition to managing the operation of the storage system, the HSV controllers serve as the interface between the storage system hardware and the SAN. All host I/Os and all HP Command View EVA management commands are processed by the controllers. Up to 18 drive enclosures are supported by one controller pair.

Racks

The rack provides the capability for mounting standard 483 mm (19 in) wide controller and drive enclosures. For additional information, see [Racks](#).

The following racks are available for the EVA8000:

- 36U Rack
- 42U Rack

**NOTE:**

- Although the 22U, 25U, 33U, and 41U rack configurations are no longer available, existing storage systems in these racks are still supported.
- Racks and rack-mountable components are typically described using “U” measurements. “U” measurements are used to designate panel or enclosure heights.

The racks provide the following:

- Unique frame and rail design—Allows fast assembly, easy mounting, and outstanding structural integrity.

- Thermal integrity—Front-to-back natural convection cooling is greatly enhanced by the innovative multi-angled design of the front door.
- Security provisions—The front and rear door are lockable, which prevents unauthorized entry.
- Flexibility—Provides easy access to hardware components for operation monitoring.
- Custom expandability—Several options allow for quick and easy expansion of the racks to create a custom solution.

2 Enterprise Virtual Array startup

This chapter describes the procedures necessary to complete the installation and configuration of the Enterprise Virtual Array. When these procedures are complete, you can begin using your storage system.



NOTE:

Installation of the Enterprise Virtual Array should be done only by an HP authorized service representative. The information in this chapter provides an overview of the steps involved in the installation and configuration of the storage system.

This chapter consists of:

- Storage system connections
- Procedures for getting started
 - Gathering information
 - Setting up the storage system hardware
 - Entering data using the Operator Control Panel (OCP)
 - Installing HP Command View EVA

EVA8000 storage system connections

Figure 2 shows how the storage system is connected to other components of the storage solution.

- The HSV210-A controllers connect via four host ports (FP1, FP2, FP3, and FP4) to the Fibre Channel fabrics. The hosts that will access the storage system are connected to the same fabrics.
- The HP Command View EVA management host also connects to the fabric.
- The controllers connect through two loop pairs to the drive enclosures. Each loop pair consists of two independent loops, each capable of managing all the disks should one loop fail. Four FC loop switches are used to connect the controllers to the disk enclosures.

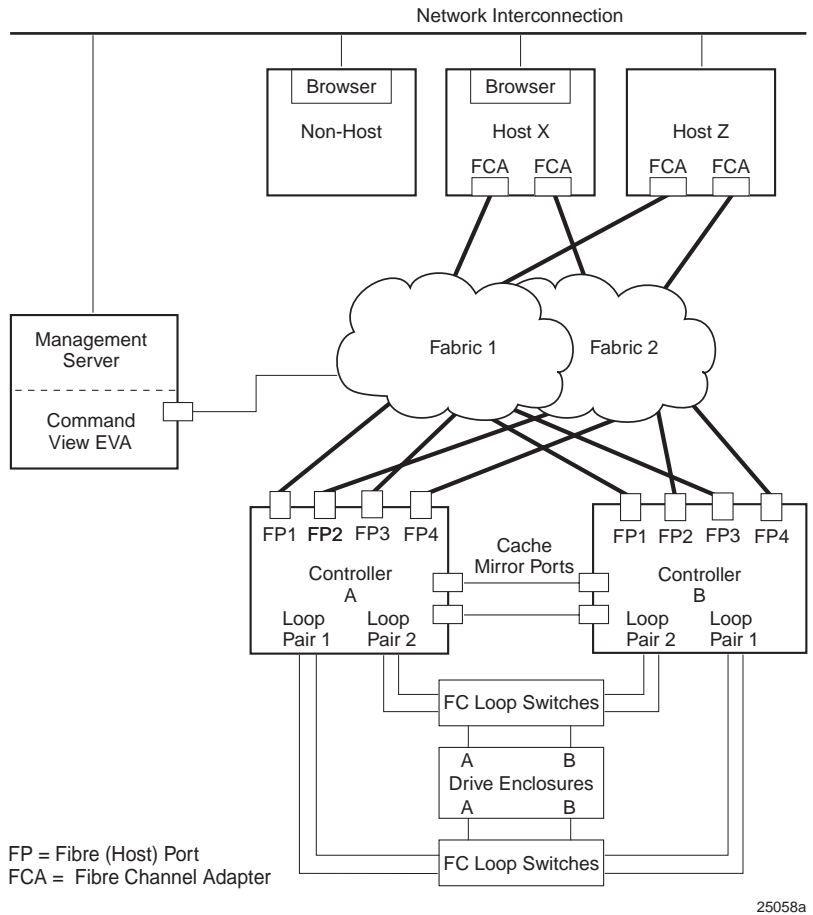

Figure 2 EVA8000 configuration

EVA6000 storage system connections

Figure 3 shows a typical Enterprise Virtual Array 6000 SAN topology:

- The HSV200-A controllers connect via two host ports (FP1 and FP2) to the Fibre Channel fabrics. The hosts that will access the storage system are connected to the same fabrics.
- HP Command View EVA, which runs on the storage management server, also connects to both fabrics.
- The controllers connect through one loop pair to the drive enclosures. The loop pair consists of two independent loops, each capable of managing all the disks should one loop fail. Two FC loop switches are used to connect the controllers to the disk enclosures.

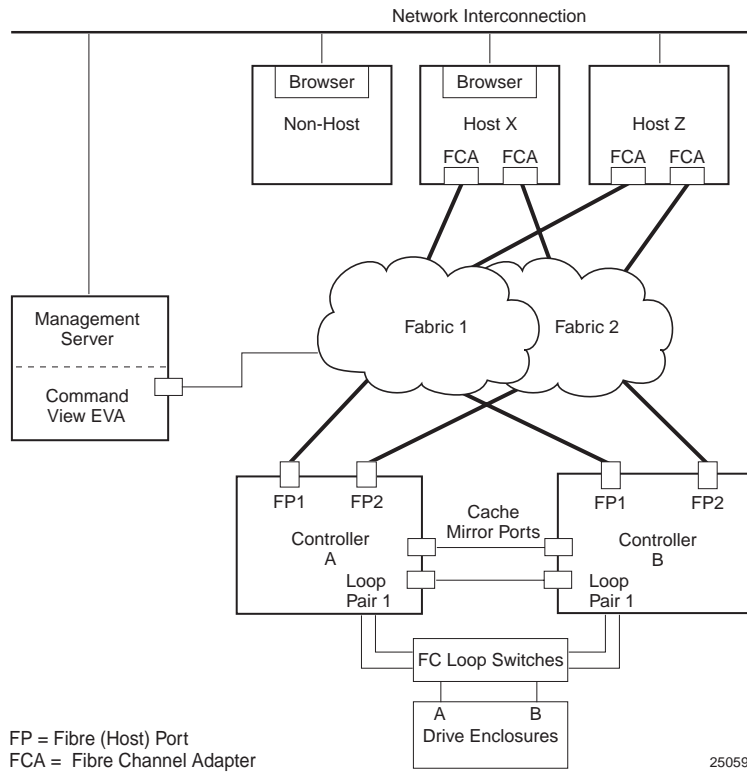
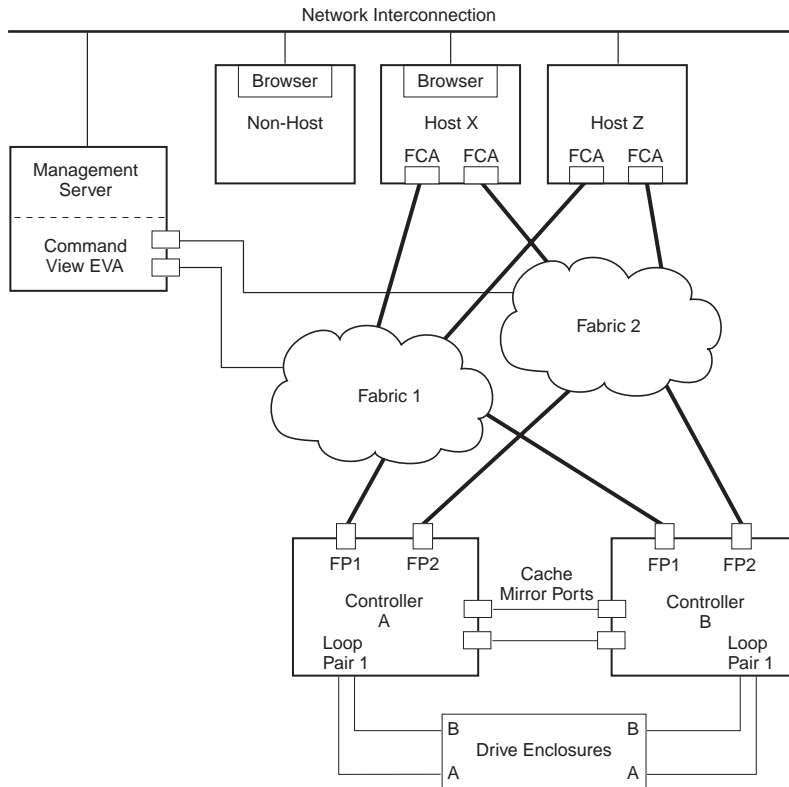

Figure 3 EVA6000 configuration

EVA4000 storage system connections

Figure 4 shows a typical Enterprise Virtual Array 4000 SAN topology:

- The HSV200-A controllers connect via two host ports (FP1 and FP2) to the Fibre Channel fabrics. The hosts that will access the storage system are connected to the same fabrics.
- HP Command View EVA, which runs on the storage management server, also connects to both fabrics.
- The controllers connect through one loop pair to the drive enclosures. The loop pair consists of two independent loops, each capable of managing all the disks should one loop fail. The controllers connect directly to the disk enclosures.



FP = Fibre (Host) Port
FCA = Fibre Channel Adapter

CX08055D

Figure 4 EVA4000 configuration

Direct connect

NOTE:

Direct connect is currently supported on Microsoft Windows only. For more information on direct connect, see the *HP StorageWorks Windows connectivity for the 4000/6000/8000 Enterprise Virtual Array release notes*. See "[Related documentation](#)" on page 13 for the link to this document.

Direct connect provides a lower cost solution for smaller configurations. When using direct connect, the storage system controllers are connected directly to the host(s), not to SAN Fibre Channel switches. Make sure the following requirements are met when configuring your environment for direct connect:

- A Windows host running HP Command View EVA must be connected to one port on each EVA controller. The management host must use dual HBAs for redundancy.
- To provide redundancy, it is recommended that dual HBAs be used for each additional host connected to the storage system. Using this configuration, up to four hosts (including the management host) can be connected to an EVA8000, and up to two hosts can be connected to an EVA6000 or EVA4000.
- The Host Port Configuration must be set to Direct Connect using the OCP.
- HP Continuous Access cannot be used with direct connect configurations.
- The HSV controller firmware cannot differentiate between an empty host port and a failed host port in a direct connect configuration. As a result, the Connection state dialog box on the Controller Properties window displays *Connection failed for an empty host port*. To fix this problem, insert an optical loop-back connector into the empty host port; the Connection state will display *Connected*. For more information about optical loop-back connectors, contact your HP-authorized service provider.

iSCSI connection configurations

The EVA4000/6000/8000 support iSCSI attach configurations using the HP MPX100. Both fabric connect and direct connect are supported for iSCSI configurations. For complete information on iSCSI configurations, go to the following web site:

<http://h18006.www1.hp.com/products/storageworks/evaiscsiconnect/index.html>



NOTE:

HP Continuous Access EVA is not supported when any port is not connected to a switch.

Fabric connect iSCSI

Fabric connect provides an iSCSI solution for EVA Fibre Channel configurations that want to continue to use all EVA ports on FC or if the EVA is also used for HP Continuous Access EVA.

Make sure the following requirements are met when configuring your MPX100 environment for fabric connect:

- A maximum two MPX100s per storage system are supported
- Each storage system port can connect to a maximum of two MPX100 FC ports.
- Each MPX100 FC port can connect to a maximum of one storage system port.
- In a single MPX100 configuration, if both MPX100 FC ports are used, each port must be connected to one storage system controller.
- In a dual MPX100 configuration, at least one FC port from each MPX100 must be connected to one storage system controller.
- The Host Port Configuration must be set to Fabric Connect using the OCP.
- HP Continuous Access EVA is supported on the same storage system connected in MPX100 fabric connect configurations.

Direct connect iSCSI

Direct connect provides a lower cost solution for configurations that want to dedicate controller ports to iSCSI I/O. When using direct connect, the storage system controllers are connected directly to the MPX100(s), not to SAN Fibre Channel switches.

Make sure the following requirements are met when configuring your MPX100 environment for direct connect:

- A maximum two MPX100s per storage system are supported
- In a single MPX100 configuration, if both MPX100 FC ports are used each port must be connected to one storage system controller.
- In a dual MPX100 configuration, at least one FC port from each MPX100 must be connected to one storage system controller.
- The Host Port Configuration must be set to Direct Connect using the OCP.
- HP Continuous Access EVA cannot be used with direct connect configurations.

Procedures for getting started

Step	Responsibility
1. Gather information and identify all related storage documentation.	Customer
2. Contact an authorized service representative for hardware configuration information.	Customer
3. Enter the World Wide Name (WWN) into the OCP.	HP Service Engineer
4. Configure HP Command View EVA.	HP Service Engineer
5. Prepare the hosts.	Customer
6. Configure the system through HP Command View EVA.	HP Service Engineer
7. Make virtual disks available to their hosts. Refer to the storage system software documentation for each host's operating system.	HP Service Engineer

Gathering information

The following items should be available when installing and configuring an Enterprise Virtual Array. They provide information necessary to set up the storage system successfully.

- *HP StorageWorks 4000/6000/8000 Enterprise Virtual Array World Wide Name label*, which is shipped with the system.
- *HP StorageWorks 4000/6000/8000 Enterprise Virtual Array read me first*.
- *HP StorageWorks 4000/6000/8000 Enterprise Virtual Array release notes*.
- The latest HP OpenView Storage Management Server Update, which consists of the management server update CD and its associated documentation, or the latest Windows Server Update
 - You can determine the latest update version available by checking the release notes or contacting your authorized service representative to find out how to receive the latest information.
 - Additional documentation is available from the following HP web site:
<http://www.hp.com/support/manuals>
Click **Storage Array Systems** under Storage, and then select the appropriate product under Enterprise Virtual Array Systems.

Locate these items and keep them handy. You will need them for the procedures in this manual.

Host information

Make a list of information for each host computer that will be accessing the storage system. You will need the following information for each host:

- The LAN name of the host
- A list of World Wide Names of the FC adapters, also called host bus adapters, through which the host will connect to the fabric or fabrics that provide access to the storage system
- Operating system type
- Available LUN numbers

Setting up a controller pair using the OCP

 **NOTE:**

This procedure should be performed by an HP authorized service representative.

Two pieces of data must be entered during initial setup using the controller OCP:

- World Wide Name (WWN)—Required to complete setup. This procedure should be performed by an HP authorized service representative.
- Storage system password—Optional. A password provides security allowing only specific instances of HP Command View EVA to access the storage system.

The OCP on either controller can be used to input the WWN and password data. For more information about the OCP, see "[Operator Control Panel](#)" on page 75.

[Table 2](#) lists the push button functions when entering the WWN, WWN checksum, and password data.

Table 2 Push button functions

Button	Function
▲	Selects a character by scrolling up through the character list one character at a time.
▶	Moves forward one character. If you accept an incorrect character, you can move through all 16 characters, one character at a time, until you display the incorrect character. You can then change the character.
▼	Selects a character by scrolling down through the character list one character at a time.
◀	Moves backward one character.
ESC	Returns to the default display.
ENTER	Accepts all the characters entered.

Entering the WWN

Fibre Channel protocol requires that each controller pair have a unique WWN. This 16-character alphanumeric name identifies the controller pair on the storage system. Two WWN labels attached to the rack identify the storage system WWN and checksum. See [Figure 5](#).

 **NOTE:**

- The WWN is unique to a controller pair and cannot be used for any other controller pair or device anywhere on the network.
 - This is the only WWN applicable to any controller installed in a specific physical location, even a replacement controller.
 - Once a WWN is assigned to a controller, you cannot change the WWN while the controller is part of the same storage system.
-

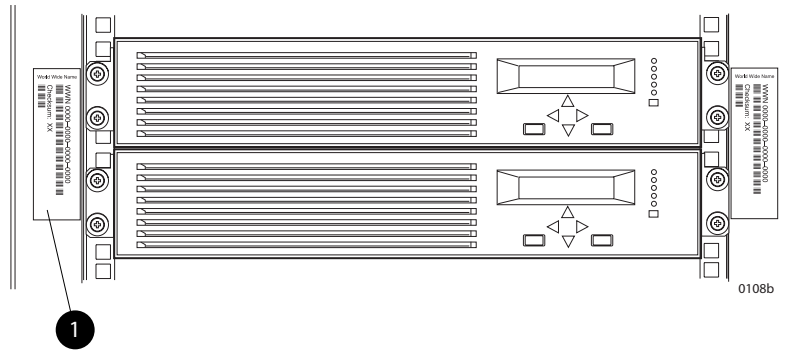

Figure 5 Location of the World Wide Name labels

1. World Wide Name labels

Complete the following procedure to assign the WWN to each pair of controllers.

1. Turn the power switches on both controllers off.
2. Apply power to the rack.
3. Turn the power switch on both controllers on.

 **NOTE:**

Notifications of the startup test steps that have been executed are displayed while the controller is booting. It may take up to two minutes for the steps to display. The default WWN entry display has a 0 in each of the 16 positions.

4. Press ▲ or ▼ until the first character of the WWN is displayed. Press ► to accept this character and select the next.
5. Repeat Step 4 to enter the remaining characters.
6. Press **Enter** to accept the WWN and select the checksum entry mode.

Entering the WWN checksum

The second part of the WWN entry procedure is to enter the two-character checksum, as follows.

1. Verify that the initial WWN checksum displays 0 in both positions.
2. Press ▲ or ▼ until the first checksum character is displayed. Press ► to accept this character and select the second character.
3. Press ▲ or ▼ until the second character is displayed. Press **Enter** to accept the checksum and exit.
4. Verify that the default display is automatically selected. This indicates that the checksum is valid.

 **NOTE:**

If you enter an incorrect WWN or checksum, the system will reject the data and you must repeat the procedure.

Entering the storage system password

The eight-character storage system password feature enables you to restrict management access to the storage system.

Complete the following procedure to set the password:

1. Select a unique, eight-character password.

2. With either of the default menus (Storage System Name or World Wide Name) displayed, press ▼ three times to display *System Password*.
3. Press ► to display *Change Password?*
4. Press **Enter** for yes.
The default password, *AAAAAAAA*, is displayed.
5. Press ▼ or ▲ to select the desired character.
6. Press ► to accept this character and select the next character.
7. Repeat the process to enter the remaining password characters.
8. Press **Enter** to enter the password and return to the default display.

Installing HP Command View EVA

HP Command View EVA is installed on the HP OpenView Storage Management Server or a Windows host and runs in the OpenView environment. Installation may be skipped if the latest version of HP Command View EVA is running. Verify the latest version at the HP web site: <http://h18006.www1.hp.com/storage/software.html>.

To install a new version, locate the management server update CD-ROM and the associated documentation that was shipped with your storage system. Follow the instructions in the *HP OpenView Storage Management Server update installation card* to install the new software.

Installing optional EVA software licenses

If you purchased optional EVA software, it will be necessary to install the license. Optional software available for the Enterprise Virtual Array includes HP Business Copy and HP Continuous Access. Installation instructions are included with the license.

3 Enterprise Virtual Array operation

This chapter presents the tasks that you might need to perform during normal operation of the storage system.

Best practices

For useful information on managing and configuring your storage system, refer to the *HP StorageWorks Enterprise Virtual Array configuration best practices* white paper available from <http://h18006.www1.hp.com/storage/arraywhitepapers.html>.

Operating tips and information

Reserving adequate free space

To ensure efficient storage system operation, a certain amount of unallocated capacity, or free space, should be reserved in each disk group. The recommended amount of free space is influenced by your system configuration. For guidance on how much free space to reserve, refer to the *HP StorageWorks Enterprise Virtual Array configuration best practices* white paper. See [Best practices](#).

Using FATA disk drives

FATA drives are designed for lower duty cycle applications such as near on-line data replication for back-up. These drives should not be used as a replacement for EVA's high performance, standard duty cycle, Fibre Channel drives. Doing so could shorten the life of the drive. Download the following document for more information on FATA drives, their uses and benefits:

<http://h71028.www7.hp.com/ERC/downloads/5982-7353EN.pdf>

Failback preference setting for HSV controllers

[Table 3](#) describes the failback preference mode for each of the operating systems supported with HSV controllers and Command View EVA.

[Table 4](#) describes the failback default behavior and settings allowed for each operating system. The table indicates when Secure Path is used in conjunction with the operating system

Table 3 Failback preference settings

Setting	Point in time	Behavior
No preference	At initial presentation	The units are alternately brought online to Controller A or to Controller B.
	On dual boot or controller resynch	If cache data for a LUN exists on a particular controller, the unit will be brought online there. Otherwise, the units are alternately brought online to Controller A or to Controller B.
	On controller failover	All LUNs are brought online to the surviving controller.
	On controller failback	All LUNs remain on the surviving controller. There is no failback except if a host moves the LUN using SCSI commands.
Path A - Failover Only	At initial presentation	The units are brought online to Controller A.
	On dual boot or controller resynch	If cache data for a LUN exists on a particular controller, the unit will be brought online there. Otherwise, the units are brought online to Controller A.
	On controller failover	All LUNs are brought online to the surviving controller.
	On controller failback	All LUNs remain on the surviving controller. There is no failback except if a host moves the LUN using SCSI commands.
Path B - Failover Only	At initial presentation	The units are brought online to Controller B.
	On dual boot or controller resynch	If cache data for a LUN exists on a particular controller, the unit will be brought online there. Otherwise, the units are brought online to Controller B.
	On controller failover	All LUNs are brought online to the surviving controller.
	On controller failback	All LUNs remain on the surviving controller. There is no failback except if a host moves the LUN using SCSI commands.

Setting	Point in time	Behavior
Path A - Failover/ Failback	At initial presentation	The units are brought online to Controller A.
	On dual boot or controller resynch	If cache data for a LUN exists on a particular controller, the unit will be brought online there. Otherwise, the units are brought online to Controller A.
	On controller failover	All LUNs are brought online to the surviving controller.
	On controller failback	All LUNs remain on the surviving controller. After controller restoration, the units that are online to Controller B and set to Path A are brought online to Controller A. This is a one time occurrence. If the host then moves the LUN using SCSI commands, the LUN will remain where moved.
Path B - Failover/ Failback	At initial presentation	The units are brought online to Controller B.
	On dual boot or controller resynch	If cache data for a LUN exists on a particular controller, the unit will be brought online there. Otherwise, the units are brought online to Controller B.
	On controller failover	All LUNs are brought online to the surviving controller.
	On controller failback	All LUNs remain on the surviving controller. After controller restoration, the units that are online to Controller A and set to Path B are brought online to Controller B. This is a one time occurrence. If the host then moves the LUN using SCSI commands, the LUN will remain where moved.

Table 4 Failback Settings by Operating System

Operating system	Default behavior	Settings supported
HP-UX	Autoback done by the host	No Preference, Path A/B - Failover Only.
Tru64 UNIX	Host follows the unit	All settings allowed. Recommended setting: Path A/B - Failover/Failback.
OpenVMS (7.3-1 and greater)	Host follows the unit	All settings allowed. Recommended setting: Path A/B - Failover/Failback.
Windows®	Auto failback done by the host	No Preference, Path A/B - Failover Only.
Sun Solaris®	Auto failback done by the host	No Preference, Path A/B - Failover Only.
IBM AIX	Auto failback done by the host	No Preference, Path A/B - Failover Only.
Linux	Auto failback done by the host	No Preference Path A/B - Failover Only
Novell NetWare	Auto failback done by the host	No Preference Path A/B - Failover Only
VMware	Auto failback done by the host	No Preference Path A/B - Failover Only

Changing virtual disk failover/failback setting

Changing the failover/failback setting of a virtual disk may impact which controller presents the disk. [Table 5](#) identifies the presentation behavior that results when the failover/failback setting for a virtual disk is changed.



NOTE:

If the new setting causes the presentation of the virtual disk to move to a new controller, any snapshots or snapclones associated with the virtual disk will also be moved.

Table 5 Impact on virtual disk presentation when changing failover/failback setting

New setting	Impact on virtual disk presentation
No Preference	None. The disk maintains its original presentation
Path A Failover	If the disk is currently presented on controller B, it is moved to controller A. If the disk is on controller A, it remains there.
Path B Failover	If the disk is currently presented on controller A, it is moved to controller B. If the disk is on controller B, it remains there.
Path A Failover/Failback	If the disk is currently presented on controller B, it is moved to controller A. If the disk is on controller A, it remains there.
Path B Failover/Failback	If the disk is currently presented on controller A, it is moved to controller B. If the disk is on controller B, it remains there.

Storage system shutdown and powerup

The storage system is shut down using HP Command View EVA. The shutdown process performs the following functions in the indicated order:

1. Flushes cache
2. Removes power from the controllers
3. Disables cache battery power
4. Removes power from the drive enclosures
5. Disconnects the system from HP Command View EVA

 **NOTE:**

The storage system may take a long time to complete the necessary cache flush during controller shutdown when snapshots are being used. The delay may be particularly long if multiple child snapshots are used, or if there has been a large amount of write activity to the snapshot source Vdisk.

Shutting down the storage system

To shut the storage system down, perform the following steps:

1. Start HP Command View EVA.
2. Select the appropriate storage system in the Navigation pane.
The Initialized Storage System Properties window for the selected storage system opens.
3. Click **System options**.
The System Options window opens.
4. Click **Shut down**.
The Shutdown Options window opens.
5. Under System Shutdown click **Power Down**. If you want to delay the initiation of the shutdown, enter the number of minutes in the Shutdown delay field.
The controllers complete an orderly shutdown and then power off. The disk enclosures then power off. Wait for the shutdown to complete.
6. Turn off the power switch on the rear of each HSV controller.
7. Turn off the circuit breakers on both of the EVA rack Power Distribution Units (PDU).
8. If your management server is an SMA and you are not using it to manage other storage arrays, shut down the SMA. From the SMA user interface, click **Settings > Maintenance > Shutdown**.

Powering up the storage system

To power up a storage system, perform the following steps:

1. Verify that each fabric Fibre Channel switch to which the HSV controllers are connected is powered up and fully booted. The power indicator on each switch should be on.
If you must power up the SAN switches, wait for them to complete their power-on boot process before proceeding. This may take several minutes.
2. If the management server you shut down is an SMA, power it on and wait for it to completely boot. Verify the SMA is running by logging into it using the web interface.

 **NOTE:**

Before applying power to the rack, ensure that the power switch on each HSV controller is off.

3. Power on the circuit breakers on both EVA rack PDUs. Verify that all drive enclosures are operating properly. The status indicator and the power indicator should be on (green).
4. Wait three minutes and then verify that all disk drives are ready. The drive ready indicator and the drive online indicator should be on (green).
5. Power on the upper controller. It takes the roll of master controller.
6. Wait 10 seconds and then power on the lower controller. It takes the roll of slave controller.
7. Verify that the (Operator Control Panel) OCP display on each controller displays the storage system name and the EVA WWN.
8. Start HP Command View EVA and verify connection to the storage system. If the storage system is not visible, click **HSV Storage Network** in the Navigation pane then click **Discover** in the Content pane to discover the array.

 **NOTE:**

If the storage system is still not visible, reboot the management server to re-establish the communication link.

9. Check the storage system status using HP Command View EVA to ensure everything is operating properly. If any status indicator is not normal, check the log files or contact your HP—authorized service provider for assistance.

Saving storage system configuration data

As part of an overall data protection strategy, storage system configuration data should be saved during initial installation, and whenever major configuration changes are made to the storage system. This includes adding or removing disk drives, creating or deleting disk groups, and adding or deleting virtual disks. The saved configuration data can save substantial time should it ever become necessary to re-initialize the storage system. The configuration data is saved to a series of files stored in a location other than on the storage system.

This procedure can be performed from the SAN Management Appliance (SMA) or management server where the Command View EVA application is installed, or any host that can run the Storage System Scripting Utility (SSSU) to communicate with the Command View EVA application server.

 **NOTE:**

SSSU version 4 is required for HP Command View EVA 4.0 and later. For more information on using SSSU, refer to the *HP StorageWorks Storage System Scripting Utility reference*, which can be downloaded from the following web site:

<http://h18006.www1.hp.com/products/storage/software/cmdvieweva/index.html>

Click **Support & Documentation**.

1. Run SSSU on the platform and operating system of your choice.
2. Enter `SELECT MANAGER` and select the management server.
3. Enter `SHOW SYSTEM` to determine which storage systems are managed by this instance of HP Command View EVA.
4. Enter `SELECT SYSTEM` to select the appropriate storage system from which to collect configuration data.

5. Enter `CAPTURE CONFIGURATION`, specifying the full path and filename of the output files for the configuration data.

The configuration data is stored in a series of from one to five files, which are SSSU scripts. The file names begin with the name you choose, with the restore step appended. For example, if you specify a file name of `LargeEVA.txt`, the resultant configuration files would be `LargeEVA_Step1A.txt`, `LargeEVA_Step1B`, etc.

The contents of the configuration files can be viewed with a text editor.

 **NOTE:**

If the storage system contains disk drives of different capacities, the SSSU procedures used do not guarantee that disk drives of the same capacity will be exclusively added to the same disk group. If you need to restore an array configuration that contains disks of different sizes and types, you must manually recreate these disk groups. The controller software and the utility's `CAPTURE CONFIGURATION` command are not designed to automatically restore this type of configuration. For more information, refer to the *HP StorageWorks Storage System Scripting Utility reference*.

The following examples illustrate how to save and restore the storage system configuration data using SSSU on a Windows host.

Example 1. Saving configuration data using SSSU on a Windows Host

Run SSSU from a DOS Command Window on the SMA, a Windows Workstation or a Windows Server that can access the SMA by TCP/IP or the management host running Command View.

1. Click **Run** on the Window Start menu.
2. Enter `cmd` in the Open field to open the DOS Command Window.
3. Change to the directory (CD) in which you have installed SSSU. For example, `C:> cd \SSSUDir`
4. Enter `SSSU` to run the application.
5. Enter `SELECT MANAGER <SMAname or ip_addr> user=<username> pass=<userpassword>`.
6. Enter `SHOW SYSTEM` to display the EVA storage systems managed by the SMA or Windows Host.
7. Enter `SELECT SYSTEM <EVA_Name>`, where `EVA_name` is the name of the storage system.

The storage system name is case sensitive. If there are spaces between the letters in the name, quotes must enclose the name. For example, `SELECT SYSTEM "Large EVA"`.

8. Enter `CAPTURE CONFIGURATION <pathname\filename>`, where `pathname` identifies the location where the configuration files will be saved, and `filename` is the name used as the prefix for the configurations files. For example, `CAPTURE CONFIGURATION c:\EVAConfig\LargeEVA`
9. Enter `EXIT` to close the DOS Command Window.

Example 2. Restoring configuration data using SSSU on a Windows Host

If it is necessary to restore the storage system configuration, it can be done using the

1. Click **Run** on the Window Start menu.
2. Enter `cmd` in the Open field to open the DOS Command Window.
3. Change to the directory (CD) in which you have installed SSSU. For example, `C:> cd \SSSUDir`
4. Enter `SSSU` to run the application.
5. Enter `FILE <pathname\filename>`, where `pathname` identifies the location where the configuration files are be saved and `filename` is the name of the first configuration file. For example, `FILE c:\EVAConfig\LargeEVA_Step1A.txt`
6. Repeat the preceding step for each configuration file.

Adding disk drives to the storage system

As your storage requirements grow, you may be adding disk drives to your storage system. Adding new disk drives is the easiest way to increase the storage capacity of the storage system. Disk drives can be added online without impacting storage system operation.

△ CAUTION:

When adding disks to an expansion cabinet on an EVA8000, do not install a disk in bays 12, 13, or 14 in enclosures 17, 20, or 24. These bays in enclosures 17, 20, and 24 do not receive a hard assigned AL-PA. Installing a disk in any of these slots may impact the operation of the storage system.

Guidelines for adding disk drives

When adding new disk drives to the storage system, you should ensure that the disk drives are installed in the correct positions to maintain availability. The disk drives should be distributed across the disk enclosures to protect against the failure of a single disk enclosure.

Use the following guidelines when adding disk drives to your storage system:

- Install high performance and FATA disk drives in separate groups. These different drive types must be in separate disk groups. You may also want to consider separating different drive capacities and spindle speeds into different groups.
- High performance and FATA disk drives can be installed in the same disk enclosure.
- The disk drives should be distributed evenly across the disk enclosures. The number of disks of a given type in each enclosure should not differ by more than one. For example, no enclosure should have two disks until all the other enclosures have at least one.
- Disk drives should be installed in vertical columns within the disk enclosures. Add drives vertically in multiples of eight, completely filling columns if possible. Disk groups are more robust if filled with the same number of disk drives in each enclosure. See [Figure 7](#) for an example.

📄 NOTE:

When adding multiple disk drives, add a disk and wait for its activity indicator (1) to stop flashing (up to 90 seconds) before installing the next disk (see [Figure 6](#)). This procedure must be followed to avoid unexpected EVA system behavior.

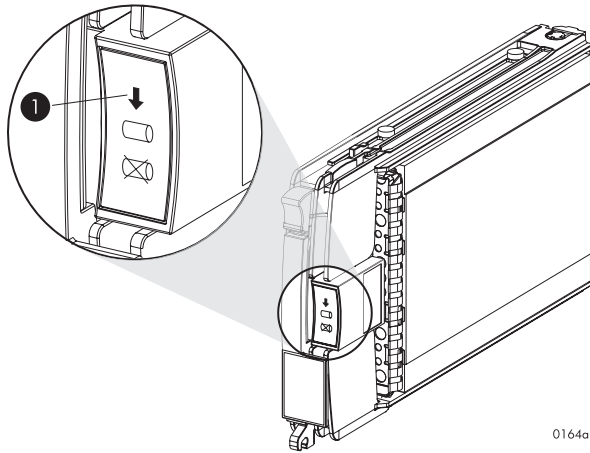

Figure 6 Disk drive activity indicator

Creating disk groups

The new disks you add will typically be used to create new disk groups. Although you cannot select which disks will be part of a disk group, you can control this by building the disk groups sequentially.

Add the disk drives required for the first disk group, and then create a disk group using these disk drives. Now add the disk drives for the second disk group, and then create that disk group. This process gives you control over which disk drives are included in each disk group. [Figure 7](#) shows the sequential building of vertical disk groups.



NOTE:

Standard and FATA disk drives must be in separate disk groups. Disk drives of different capacities and spindle speeds can be included in the same disk group, but you may want to consider separating them into separate disk groups.

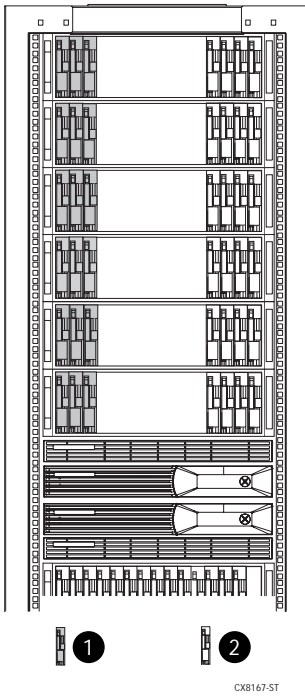

Figure 7 Sequential building of vertical disk groups

1. Disks installed in first group
2. Disks installed in second group

Adding a disk drive

This section describes the procedure for adding a Fibre Channel disk drive.

Removing the drive blank

1. Grasp the drive blank by the two mounting tabs (see [Figure 8](#)).
2. Lift up on the lower mounting tab and pull the blank out of the enclosure.

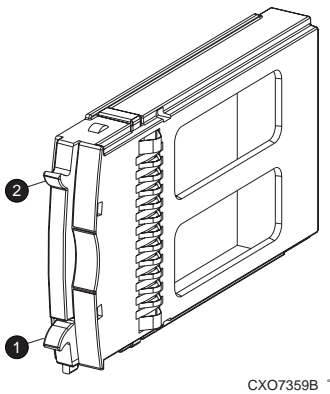

Figure 8 Removing the drive blank

1. Upper mounting tab
2. Lower mounting tab

Changing the Device Addition Policy

To prevent the storage system from automatically grouping a new disk drive that may have the incorrect firmware on it, the Device Addition Policy must be checked and set to manual if necessary:

1. Open Command View EVA and in the Navigation pane select the storage system.
The Initialized Storage System Properties window opens.
2. Click **System Options**
3. Select **Set system operational policies**
4. If the Device Addition Policy is set to **Automatic**, change it to **Manual**
5. Click **Save changes**

 **NOTE:**

If you want to return the Device Addition Policy to automatic, use the above procedure to do so after verifying the disk drive has the correct firmware version.

Installing the disk drive

1. Push in the ejector button on the disk drive and pull the release lever down to the full open position.
2. Insert the drive into the enclosure as far as it will go (1, [Figure 9](#)).
3. Close the release lever until it engages the ejector button, and the disk drive seats in the backplane (2, [Figure 9](#)).
4. Press in firmly on the disk drive to ensure it is seated properly.

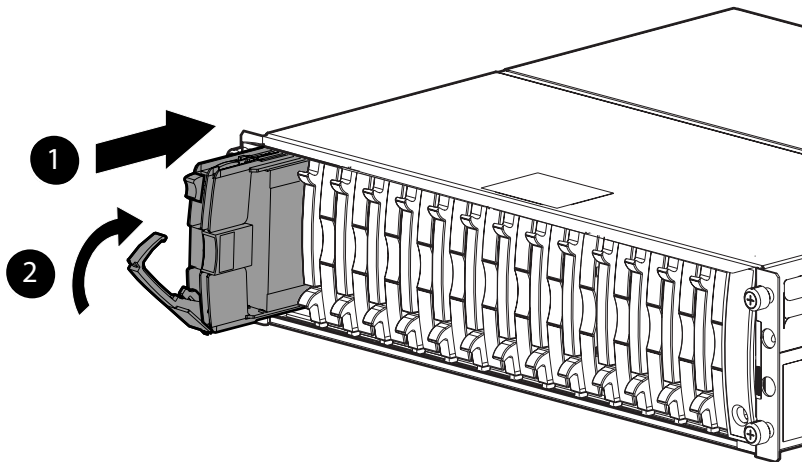

0116a

Figure 9 Installing the disk drive

Checking status indicators

After replacing the disk drive, check the following to verify that the disk drive is operating normally:

 **NOTE:**

It may take up to 10 minutes for the component to display good status.

- Check the disk drive status indicators. See [Figure 10](#).

- Activity indicator (1) should be on or flashing
- Online indicator (2) should be on or flashing
- Fault indicator (3) should be off
- Check the following using Command View EVA.
 - Navigate to the disk drive and check the operational state. It should be .
 - Record the **Model number** and the **Firmware version**. Check the firmware version against the supported disk firmware in the *HP StorageWorks Enterprise Virtual Array release notes*. The most current edition of the release notes can be downloaded from the following web site:

<http://www.hp.com/go/eva8000>

Click **Technical documentation**.

If the disk drive is using an unsupported version of firmware, download the correct firmware from the following web site and install it using the instructions included with the firmware file. Use the disk drive model number to locate the correct firmware file. Do not add the disk drive to a disk group if it using an unsupported firmware version.

<http://www.hp.com/support/evadiskfirmware>

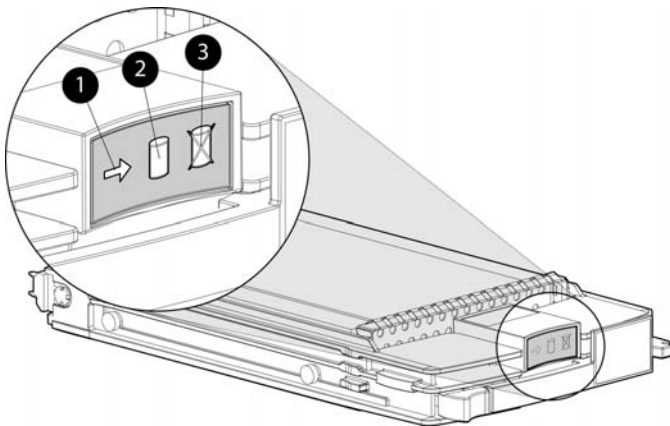

Figure 10 Disk drive status indicators

- | | |
|-------------|-----------|
| 1. Activity | 2. Online |
| 3. Fault | |

Adding the disk to a disk group

After replacing the disk, it should be added to a disk group.

1. In the Navigation pane, select **Storage system > Hardware > Rack > Disk enclosure > Bay**
2. In the Content pane, select the **Disk Drive** tab.
3. Click **Group** to initiate the process for adding the disk to a disk group.

NOTE:

If the Device Addition Policy is set to automatic, the disk will automatically be added to a disk group. In this case the **Group** option will not be available.

Handling fiber optic cables

This section provides protection and cleaning methods for fiber optic connectors.

Contamination of the fiber optic connectors on either a transceiver or a cable connector can impede the transmission of data. Therefore, protecting the connector tips against contamination or damage

is imperative. The tips can be contaminated by touching them, by dust, or by debris. They can be damaged when dropped. To protect the connectors against contamination or damage, use the dust covers or dust caps provided by the manufacturer. These covers are removed during installation, and are installed whenever the transceivers or cables are disconnected. Cleaning the connectors should remove contamination.

The transceiver dust caps protect the transceivers from contamination. **Do not discard the dust covers.**

△ **CAUTION:**

To avoid damage to the connectors, always install the dust covers or dust caps whenever a transceiver or a fiber cable is disconnected. Remove the dust covers or dust caps from transceivers or fiber cable connectors only when they are connected. **Do not discard the dust covers.**

To minimize the risk of contamination or damage, do the following:

- **Dust covers**—Remove and set aside the dust covers and dust caps when installing an I/O module, a transceiver or a cable. Install the dust covers when disconnecting a transceiver or cable.
- **When to clean**—If a connector may be contaminated, or if a connector has not been protected by a dust cover for an extended period of time, clean it.
- **How to clean:**
 1. Wipe the connector with a lint-free tissue soaked with 100% isopropyl alcohol.
 2. Wipe the connector with a dry, lint-free tissue.
 3. Dry the connector with moisture-free compressed air.

One of the many sources for cleaning equipment specifically designed for fiber optic connectors is:

Alcoa Fujikura Ltd.

1-888-385-4587 (North America)

011-1-770-956-7200 (International)

4 Enterprise Virtual Array hardware components

This chapter describes the Enterprise Virtual Array hardware components. Topics to be discussed include:

- Fibre Channel drive enclosures
- Fibre Channel loop switches
- HSV controllers
- Racks

Fibre Channel drive enclosures

The drive enclosure contains the disk drives used for data storage. A storage system includes multiple drive enclosures. The major components of the enclosure are:

- 2.125-Gb, dual loop, 14-drive enclosure
- Dual-loop, Fibre Channel drive enclosure I/O modules
- Copper Fibre Channel cables
- Fibre Channel disk drives and drive blanks
- Power supplies
- Blowers
- Cache batteries
- EMU

Enclosure layout

The disk drives mount in [bays](#) in the front of the enclosure. The bays are numbered sequentially from left to right. A drive is referred to by its bay number. Enclosure status indicators are located in the lower-right, front corner. [Figure 11](#) shows the front and rear views of the FC drive enclosure.

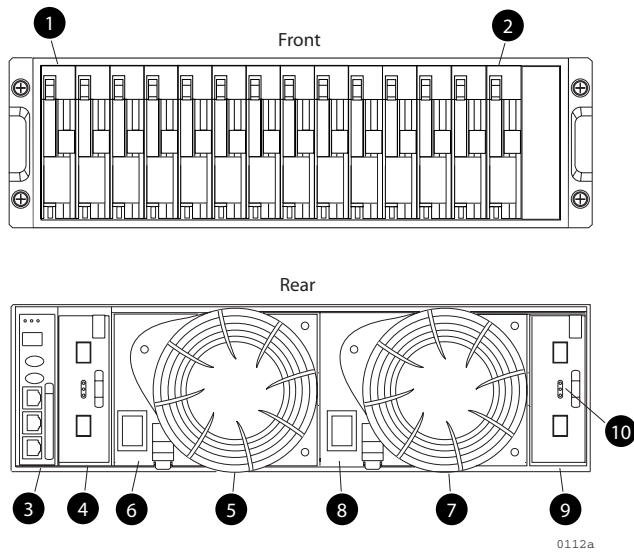

Figure 11 FC drive enclosure—front and rear views

- | | |
|-----------------|---|
| 1. Drive bay 1 | 2. Drive bay 14 |
| 3. EMU | 4. I/O module B |
| 5. Blower 1 | 6. Power supply 1 |
| 7. Blower 2 | 8. Power supply 2 |
| 9. I/O module A | 10. Status indicators (EMU, enclosure power, enclosure fault) |

I/O modules

Two I/O modules provide the interface between the drive enclosure and the host controllers. See [Figure 12](#). They route data to and from the disk drives using Loop A and Loop B, the dual-loop configuration. For redundancy, only dual-controller, dual-loop operation is supported. Each controller is connected to both I/O modules in the drive enclosure.

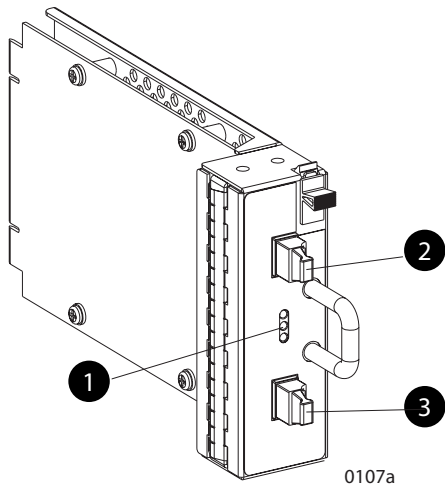

Figure 12 I/O module

1. Status indicators (Upper port, Power, and Lower port)
2. Upper port
3. Lower port

The I/O modules are functionally identical, but are not interchangeable. Module A can only be installed at the right end of the enclosure, and module B can only be installed at the left end of the enclosure. See [Figure 11](#).

Each I/O module has two ports that can both transmit and receive data for bidirectional operation. Activating a port requires connecting a FC cable to the port. The port function depends upon the loop. See [Figure 13](#).

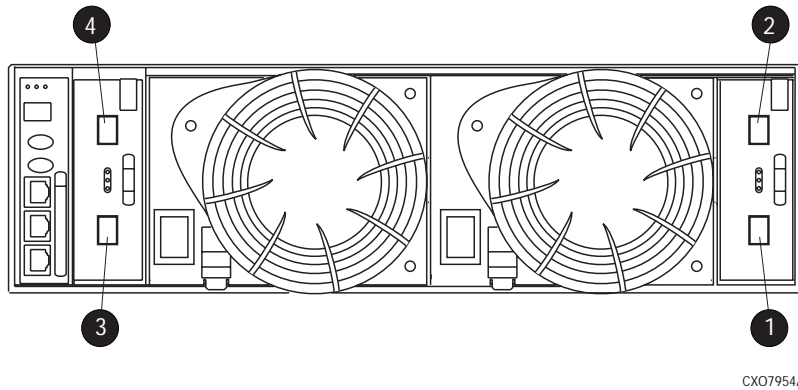

Figure 13 Input and output ports

- | | |
|----------------------|----------------------|
| 1. Loop A lower port | 2. Loop A upper port |
| 3. Loop B lower port | 4. Loop B upper port |

I/O module status indicators

There are three status indicators on the I/O module. See [Figure 12](#). The status indicator states for an operational I/O module are shown in [Table 6](#). [Table 7](#) shows the status indicator states for a non-operational I/O module.

Table 6 Operational I/O module status indicators

Upper	Power	Lower	Descriptions
Off	On	Off	<ul style="list-style-type: none"> I/O Module is operational
On	Flashing, then On	On	<ul style="list-style-type: none"> Top port—Fibre Channel drive enclosure signal detected. Power—Flashes for about 90 seconds after initial power application, then remains constant. Bottom port—Fibre Channel drive enclosure signal detected.
On	On	On	<ul style="list-style-type: none"> Top port—Fibre Channel drive enclosure signal detected. Power—Present. Bottom port—Fibre Channel drive enclosure signal detected.
Flashing	Flashing	Flashing	<ul style="list-style-type: none"> When the locate function is active, all three indicators flash simultaneously. The Locate function overrides all other indicator functions. Therefore, an error could be detected while the Locate function is active and not be indicated until the Locate action terminates.

Table 7 Non-operational I/O module status indicators

Upper	Power	Lower	Descriptions
On	On	Off	<ul style="list-style-type: none"> Top port—Fibre Channel drive enclosure signal detected. Power—Present. Bottom port—No Fibre Channel drive enclosure signal detected. Check transceiver and fiber cable connections. <p>NOTE: This status applies to configurations with and without FC loop switches.</p>
Off	On	On	<ul style="list-style-type: none"> Top port—No Fibre Channel drive enclosure signal detected. Check transceiver and fiber cable connections. Power—Present. Bottom port—Fibre Channel drive enclosure signal detected .
Flashing	On	On	<ul style="list-style-type: none"> Top port—EMU detected possible transceiver problem. Check transceiver and fiber cable connections. Power—Present. Bottom port—Fibre Channel drive enclosure signal detected .
On	On	Flashing	<ul style="list-style-type: none"> Top port—Fibre Channel drive enclosure signal detected. Power—Present. Bottom port—EMU detected possible transceiver problem. Check transceiver and fiber cable connections. <p>NOTE: The EMU will not flash the lower indicator on its own. It will flash only in response to a locate command. You can flash each of the lights independently during a locate action.</p>
Off	Off	Off	<ul style="list-style-type: none"> No I/O module power. I/O module is nonoperational. Check power supplies. If power supplies are operational, replace I/O module.

Fibre Optic Fibre Channel cables

The Enterprise Virtual Array uses orange, 50- μ m, multi-mode, fiber optic cables for connection to the SAN. The fiber optic cable assembly consists of two, 2-m fiber optic strands and small form-factor connectors on each end. See [Figure 14](#).

To ensure optimum operation, the fiber optic cable components require protection from contamination and mechanical hazards. Failure to provide this protection can cause degraded operation. Observe the following precautions when using fiber optic cables.

- To avoid breaking the fiber within the cable:
 - Do not kink the cable
 - Do not use a cable bend-radius of less than 30 mm (1.18 in)
- To avoid deforming, or possibly breaking the fiber within the cable, do not place heavy objects on the cable.
- To avoid contaminating the optical connectors:
 - Do not touch the connectors
 - Never leave the connectors exposed to the air
 - Install a dust cover on each transceiver and fiber cable connector when they are disconnected

If an open connector is exposed to dust, or there is any doubt about the cleanliness of the connector, clean the connector as described in [Handling fiber optic cables](#).

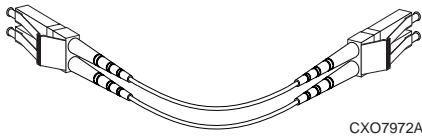

Figure 14 Fibre Optic Fibre Channel cable

Copper Fibre Channel cables

The Enterprise Virtual Array uses copper Fibre Channel cables to connect the drive enclosures to each other, or to the loop switches and to the HSV controllers. The cables are available in 0.6-meter and 2.0-meter lengths. Copper cables provide performance comparable to fiber optic cables. Copper cable connectors differ from fiber optic small form-factor connectors (see [Figure 15](#)).

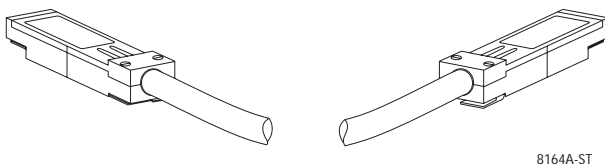

Figure 15 Copper Fibre Channel cable

Fibre Channel disk drives

The Fibre Channel disk drives are [hot-pluggable](#) and include the following features:

- Dual-ported 2-Gbps Fibre Channel drive enclosure interface that allows up to 120 disk drives to be supported per Fibre Channel drive enclosure pair.
- Compact, direct-connect design for maximum storage density and increased reliability and signal integrity.
- Both online high-performance disk drives and FATA disk drives in a variety of capacities and spindle speeds.
- Better vibration damping for improved performance.

Up to 14 disk drives can be installed in a drive enclosure.

Disk drive status indicators

Three status indicators display the drive operational status. [Figure 16](#) shows the disk drive status indicators. [Table 8](#) provides a description of each status indicator.

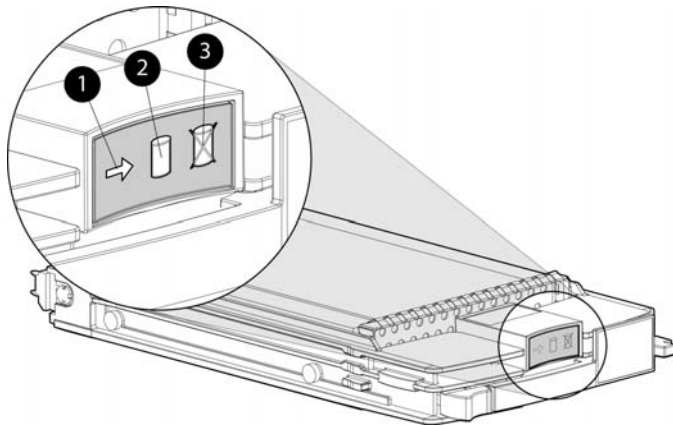





Figure 16 Disk drive status indicators

1. Activity
2. Online
3. Fault

Table 8 Disk drive status indicator descriptions

Status indicator	Description
Activity 	This green status indicator flashes when the disk drive is being accessed. It is on when the drive is idle.
Online 	The green status indicator is on when the disk drive is online and operating normally. This indicator will be off in the following situations: <ul style="list-style-type: none">• There is no controller on the bus.• +5.1 VDC is not available.• The drive is not properly installed in the enclosure.
Fault 	This amber status indicator is on when there is a disk drive failure. Depending on the host controller, this indicator may flash when the controller detects an error condition. The amber status indicator flashes in synchronization with the other two status indicators in response to the EMU locate command.

Disk drive status displays

The disk drive status indicators can assume three states: on, off, or flashing. The status indicators states for operational drive status are shown in [Table 9](#). See [Table 10](#) for the non-operational drive status indicator states.

Table 9 Operational disk drive status indications

Activity	Online	Fault	Description
Flashing	On	Off	Initial startup.
On	On	Off	The drive is online but is not being accessed.
Flashing	Flashing	Flashing	The drive is being located.
Flashing	On	Off	The drive is operational and active.

Table 10 Non-operational disk drive status indications

Activity	Online	Fault	Description
On	On	On	Indicates no connection or the controllers are offline. Recommended corrective actions: <ol style="list-style-type: none"> 1. Check power supplies for proper operation. 2. If defective, replace disk drive.
On	Off	Flashing	Indicates disk drive error/not active. Recommended corrective actions: <ol style="list-style-type: none"> 1. Verify FC loop continuity. 2. Replace disk drive.

Disk drive blank

To maintain the proper enclosure air flow, a disk drive or a disk drive blank must be installed in each drive bay. The disk drive blank maintains proper airflow within the disk enclosure.

Power supplies and blowers

This section describes the function and operation of the disk enclosure power supplies and blowers. [Figure 17](#) illustrates the major power supply and cooling components.

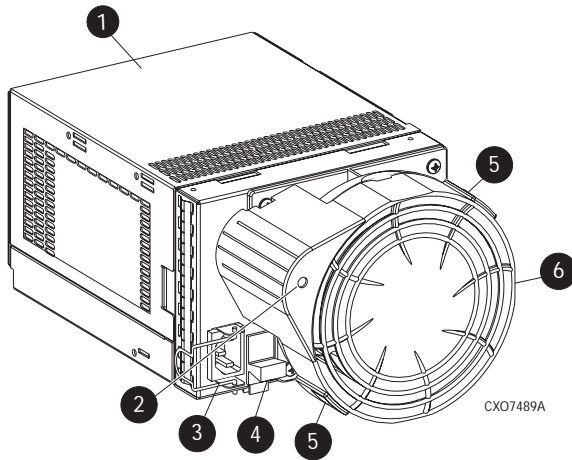

Figure 17 Power supply and blower assembly components

1. Power supply
2. Status indicator
3. AC Input connector with bail
4. Module latch (wine-colored)
5. Blower tabs (wine-colored)
6. Blower

Power supplies

The two power supplies mount in the rear of the enclosure. See [Figure 28](#). The supplies are autoranging and operate on a country-specific AC input voltage of 202 to 240 VAC $\pm 10\%$, 50 to 60 Hz, $\pm 5\%$, (188 to 264 VAC, 47 to 63 Hz).

The DC outputs of this power supply are:

- +5.1 VDC for the EMU, I/O module, [backplane](#), and disk drives
- +12.1 VDC for the disk drives
- +12.5 VDC for the disk drives

The output of each power supply is 499 W, with a peak output of 681 W. A single power supply can support an enclosure with a full complement of disks.

The power supply circuitry provides protection against:

- Overloads
- Short circuits
- Overheating

Power supply status and diagnostic information is reported to the EMU with voltage, current, and temperature signals.

See [Regulatory Notices and Specifications](#) for the enclosure power specifications.

The power supply temperature sensor provides a temperature range signal to the EMU, which uses this signal to set the [blower](#) speed.

The power supply internal temperature can also control the speed of the blower. The higher the power supply temperature, the faster the speed of the blower. If the power supply temperature exceeds a preset value, the power supply automatically shuts down.

Blowers

The power supply–mounted blowers cool the enclosure by circulating air through the enclosure. The blowers, under the control of the EMU or the associated power supply, can operate at multiple speeds. This ensures that when the enclosure temperature changes the blowers can automatically adjust the air flow.

If a blower is operating too slowly or has stopped (a “blower failure”), internal circuitry automatically operates the remaining blower at a higher speed. Simultaneously, the error condition is reported in several ways, including the power supply indicator, the audible alarm, the enclosure fault indicators, and the EMU alphanumeric display.

Should both blowers fail, the power supplies automatically shut down.

NOTE:

The blowers are field-replaceable units and can be replaced, individually, while the system is running. The blowers are also interchangeable. The failure of a power supply +12.5 VDC circuit disables the associated blower.

The status indicator on the blower displays the status of both the power supply and the blower. See [Figure 17](#). See [Table 11](#) for definitions of the indicator displays.

Table 11 Power supply/blower status indicators

Blower status indicator	Description
On	Both the power supply and the blower are operational.
Flashing	The power supply or the blower locate function is active.
Off	The power supply or the blower is non–operational. When there is a blower problem, the other blower runs at a higher speed. Recommended corrective actions: <ul style="list-style-type: none">• Check blower for proper operation. Replace if defective.• Check power supplies for proper operation. Replace if defective.

Drive enclosure EMU

The EMU provides increased protection against catastrophic failures. The EMU detects conditions such as failed power supplies, failed blowers, elevated temperatures, and external air sense faults and communicates these conditions to the storage system controllers.

The EMU for Fibre Channel-Arbitrated Loop (FC–AL) drive enclosures is fully compliant with SCSI-3 Enclosure Services (SES), and mounts in the left rear bay of a drive enclosure. See [Figure 11](#).

Controls and displays

[Figure 18](#) illustrates the location and function of the EMU displays, controls, and connectors.

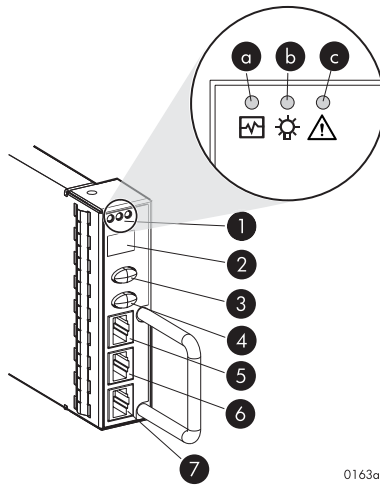

0163a

Figure 18 EMU controls and displays

1. Status indicators:
 - a.** EMU—This flashing green is the heartbeat for an operational EMU.
 - b.** Enclosure power—When both the +5 VDC and +12 VDC are correct, this green indicator is on.
 - c.** Enclosure fault—This amber indicator is normally off. The indicator is lit when an enclosure error condition exists.
2. Alphanumeric display—A two-character, seven-segment alphanumeric display of the enclosure functions and status.
3. Function select button—The primary function of this button is to select a display group function. The indicator is on when an error condition exists.
4. Display group select button—This button is used to view display groups and control the audible alarm. The indicator is on when the audible alarm is muted or disabled.
5. RS232 – for use by HP-authorized service representatives
6. LCD ONLY—unused
7. CAB ONLY—enclosure address bus connector

⚠ WARNING!

To reduce the risk of electrical shock, fire, or damage to the equipment, do not plug telephone or telecommunications connectors into the "RS232 ONLY" receptacle.

EMU functions

The primary functions of the EMU include:

- Using the Enclosure Services Processor (ESP) to control the Enclosure Services Interface (ESI) and communicate with the controllers.
- Assigning the Enclosure Number (En), based upon the cabinet address bus feature.
- Displaying the bay 1 loop ID.
- Monitoring enclosure operation.
- Detecting, reporting, recording, and displaying conditions.
- Displaying EMU, enclosure, and element status.
- Implementing automatic corrective actions for some conditions.
- Providing enclosure status data to the controllers.
- Reporting the WWN and the logical address of all disk drives.

**NOTE:**

Although the EMU can determine the logical address of a drive, the EMU can neither display nor change this information. HP Command View EVA can display the addresses from the EMU-supplied status information.

EMU monitoring functions

The internal EMU circuitry monitors the enclosure and component functions listed in [Table 12](#).

Table 12 EMU monitoring functions

Component	Monitored Functions	
Blowers	<ul style="list-style-type: none"> • Installation • Removal 	<ul style="list-style-type: none"> • Type • Speed (rpm)
Disk drives	<ul style="list-style-type: none"> • Installation • Removal • Bypass status 	<ul style="list-style-type: none"> • Loop ID • Temperature • Drive fault
EMU	<ul style="list-style-type: none"> • Temperature • Operation 	<ul style="list-style-type: none"> • Type • Revision level
Enclosure	<ul style="list-style-type: none"> • Enclosure power • Enclosure fault 	<ul style="list-style-type: none"> • Backplane type • Backplane revision level
I/O module	<ul style="list-style-type: none"> • Installation • Removal • Status 	<ul style="list-style-type: none"> • Type • Revision level
Power supplies	<ul style="list-style-type: none"> • Installation • Removal • Status • Type • Revision level 	<ul style="list-style-type: none"> • +5 VDC voltage and current • +12 VDC voltage and current • Total power • Temperature
Transceiver	<ul style="list-style-type: none"> • Type 	<ul style="list-style-type: none"> • Link status

EMU displays

The EMU uses a combination of status indicators, alphanumeric display, and an audible alarm to indicate the operational status of the enclosure and its components. See [Table 13](#).

Table 13 EMU status displays

Display	Function
Audible alarm (For information on the audible alarm, see " Audible Alarm Operations " on page 61.)	Any EMU-detected condition causes this alarm to sound.
Status indicators (For a description of the status indicators, see " EMU LED Displays " on page 60.) 	Display enclosure and EMU status.
Alphanumeric display (For a description of the alphanumeric display, see " Using the Alphanumeric Display " on page 60.)	The two-character, seven-segment display displays alphanumeric characters.

EMU indicator displays

The EMU status indicators are located above the alphanumeric display. See [Figure 18](#). These indicators present the same information as those on the front, lower right corner of the enclosure.

You can determine the EMU and enclosure status using the information in [EMU LED displays table](#).

Table 14 EMU status indications

EMU indicator (green)	Power indicator (green)	Fault indicator (amber)	Status and recommended actions
Flashing	Flashing	Flashing	The EMU Locate function is active. This display has precedence over all others. Fault conditions cannot be displayed when the Locate function is active.
Flashing	On	Off	The EMU is operational. The enclosure power (both +5 VDC and +12 VDC) is present and correct. There are no enclosure faults.
Flashing	On	On	The EMU is operational. There is an enclosure fault. Check the alphanumeric display error code for information about the problem.
Flashing	Off	Off	The EMU is operational. This display may be present when power is initially applied to the enclosure. Note: When the +5 VDC is incorrect, all the indicators are off.
On	On	Off	There is an EMU fault. There is no enclosure fault.
Off	On	Off	There is an EMU fault. There is no enclosure fault.
Off	Off	Off	There is an enclosure fault. Either +5 VDC is incorrect, or both +5 VDC and +12 VDC are incorrect. Other error conditions may exist.

Using the alphanumeric display

The two-character alphanumeric display is located at the top of the EMU (see [Figure 18](#)). This seven-segment display provides information about multiple enclosure functions. The push buttons control the data displayed or entered.

Alphanumeric display description

The top-level, two-character alphanumeric display (En, Li, rG, Au, and Er), is the display group. The function of the other displays is display-group dependent. The default display is the enclosure number, a decimal number in the range 00 through 14. The push buttons allow you to select the alphanumeric display or to enter data.

- The bottom push button sequentially moves between groups and selects a display group . See [EMU display groups](#) for a description of these display groups.
- The top push button moves between the levels within a display group (see 2, [Figure 18](#)).

Display groups

When you press and release the bottom push button, the alphanumeric display selects a different display group. [EMU display groups](#) describes the display groups.

Table 15 EMU display groups

Display	Display group	Description
En	Enclosure Number	The enclosure number is the default display and is a decimal number in the range 00 through 14. See Using the Enclosure Number Feature for detailed information.
Li	Bay 1 Loop ID	This display group has a single sublevel display that defines the enclosure bay 1 loop ID. Valid loop IDs are in the range 00 through 7F.
rG	Reporting Group	This display group has two, two-digit displays that define the reporting group number in the range 0000 through 4095.
Au	Audible Alarm	This display group provides control over the audible alarm or horn. The sublevel displays are audible alarm enabled (on) or audible alarm disabled (oF). See Audible Alarm Operations for detailed information.
Fr	Firmware Revision	This display group defines the EMU code firmware version.
Er	Error Condition	This display group reads Er when there is an error condition.

**NOTE:**

Any time you press and release the bottom push button the display will change to En, Li, rG, Au, or Er.

A flashing alphanumeric display indicates that you can edit an address, state, or view a condition report.

EMU push button status indicators

The push button status indicators display error conditions and the state of the [audible alarm](#).

- When an error condition exists, the top push button status indicator is On.
 - For a single error condition, the status indicator is On until the error condition is viewed.
 - For multiple errors, the status indicator is On until the last error condition is viewed.
- The bottom push button indicator is On only when the alarm is muted or disabled.

Audible alarm operations

Whenever an error condition exists, the [audible alarm](#) automatically sounds until all errors are corrected. You have the option of either muting or disabling the alarm.

- Disabling the audible alarm prevents it from sounding for any error condition.
- Muting the alarm silences it for the existing condition, but any new condition causes the alarm to sound.

Audible alarm patterns

The audible alarm sound pattern differs depending on the type of error condition. See [Table 16](#) for the duration and the approximate relationship of these alarms. The most severe, active error condition controls the alarm pattern.

Table 16 Audible alarm sound patterns

Condition type	Cycle 1	Cycle 2
UNRECOVERABLE		
CRITICAL		
NONCRITICAL		
INFORMATION		
Legend	 Alarm On	Alarm Off

Controlling the audible alarm

You can control the alarm with the push buttons. This process includes muting, enabling, and disabling. When an error condition exists, the alphanumeric display reads *Er*, the alarm sounds, and you can:

- Correct all errors, thereby silencing the alarm until a new error occurs.
- Mute, or temporarily disable, the alarm by pressing and holding the bottom push button. The alarm remains off until another error occurs, or until you enable (unmute) the alarm. When a new error occurs, the alarm sounds and the push button indicator is off.
Using the mute feature ensures that you are aware of the more severe errors and provides you with the capability of correcting them promptly.
- Disable the alarm to prevent any error condition from sounding the alarm.

NOTE:

Disabling the alarm does not prevent the EMU alphanumeric display from displaying *Er*. Nor does it prevent HP Command View EVA from displaying the error condition report.

When the alarm is enabled (on), the bottom push button status indicator is off.

Enabling the audible alarm

To enable the alarm:

1. Press and release the bottom push button until the alphanumeric display is *Au*.
2. Press and hold the top push button until the alphanumeric display is a Flashing *oF* (Audible Alarm Off).

NOTE:

When the alarm display is flashing, press and hold the top push button to cause the display to toggle between *On* and *oF*. Press and release the top push button to cause the display to select the next state.

3. Press and release the top push button to change the display to a flashing *On* (Audible Alarm On).
4. Press and release the bottom push button to accept the change and to display *Au*. The bottom push button indicator is now off.

Muting or unmuting the audible alarm

You may want to mute the alarm in the following situations:

- The error does not require immediate corrective action.
- You cannot correct the error at this time. For example, the error may require a replacement part.

To mute the **audible alarm**:



NOTE:

Er is displayed in the alphanumeric display when an error condition is present.

1. Press and hold the bottom push button until the status indicator is *On*.
A muted alarm will remain off until a new condition report exists.
2. To unmute the alarm, press and hold the bottom push button until the status indicator is *Off*. When a new error condition occurs, the alarm will sound.

Disabling the audible alarm



CAUTION:

Disabling the audible alarm increases the potential of damage to equipment from a reported but unobserved fault. HP does not recommend disabling the audible alarm.

Disabling the audible alarm affects only one enclosure. This action does not affect condition report displays on the EMU alphanumeric display or errors reported by HP Command View EVA.

To disable the alarm:

1. Press and release the bottom push button until the alphanumeric display is *Au*.
2. Press and hold the top push button until the alphanumeric display is a Flashing *on* (Audible Alarm On).



NOTE:

When the alarm display is flashing, pressing and holding the top push button causes the display to rapidly change between *on* and *oF* and also causes the display to select the next state.

3. Press and release the top push button to change the display to a Flashing *oF* (Audible Alarm Off).
4. Press and release the bottom push button to accept the change and display *Au*. The bottom push button indicator is now on.



NOTE:

A disabled **audible alarm** (the bottom push button indicator is on) cannot sound for any error condition. To ensure that you are immediately alerted to error conditions, it is recommended that the alarm mute function be used rather than the alarm disable function. If you must use the disable function, remember to enable the audible alarm as soon as possible to ensure that you are alerted to errors.

Enclosure number feature

This section provides a description of the purpose, function, and operation of the EMU enclosure number (En) feature.

En description

In a single rack configuration, the En is a decimal number in the range 00 through 14, which is automatically assigned by the enclosure address bus.

NOTE:

Your storage system may use an enclosure address bus higher than 14 if your configuration includes an optional expansion cabinet. The enclosure address bus connection determines the En. For a single rack, the display is a decimal number in the range 01 through 14. For a multiple (two) rack configuration, the display is decimal number in the range 01 through 24.

By default, the two-character alphanumeric display shows this number. Pressing the bottom push button changes the display to *En*, the En display mode.

When the display is *En*, pressing and releasing the top push button displays the enclosure number.

A display of 00 indicates that the enclosure is not connected to the enclosure address bus. When this condition exists, there is no EMU-to-EMU communication over the enclosure address bus.

A display of 01 through 14 indicates that the enclosure is connected to the enclosure address bus and can exchange information with other enclosures on the enclosure address bus. The decimal number indicates the physical position of the enclosure in relation to the bottom of the rack.

- 01 is the address of the enclosure connected to the lower connector in the first (lower) enclosure ID expansion cable.
- 14 is the address of the enclosure closest to end of the bus, the upper connector in the last (upper) ID expansion cable.

Unless there is an error condition, the display automatically returns to the enclosure number (01 through 14) one minute after a push button was last pressed.

Enclosure address bus

The enclosure address bus provides a means for managing and reporting environmental conditions within the rack. It is composed of enclosure ID expansion cables that interconnect the drive enclosures and controller enclosures. Two drive enclosures connect to each enclosure ID expansion cable.

The drive enclosure numbers are always assigned by the enclosure address bus. Connecting the EMU CAB connector to an enclosure address bus enclosure ID expansion cable automatically establishes an enclosure number of 01 through 14. Any drive enclosure not connected to the enclosure address bus has the enclosure number 00.

NOTE:

The enclosure number is automatically assigned. You cannot manually assign an enclosure number.

The enclosures are numbered as shown in [Figure 19](#).

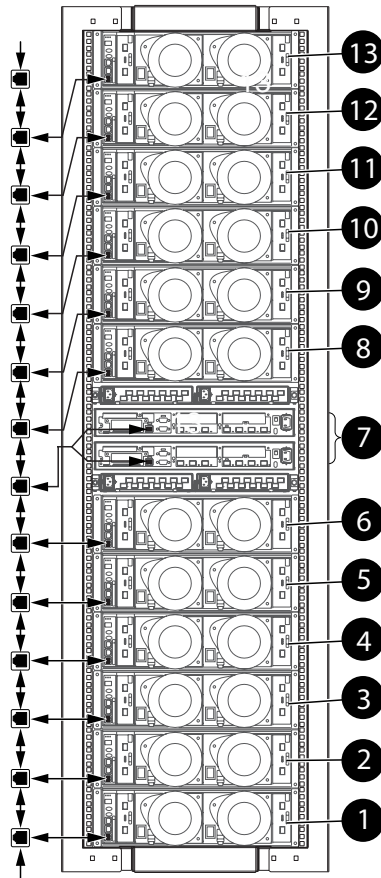

0046a-2

Figure 19 Enclosure numbering with enclosure ID expansion cables



NOTE:

If an expansion rack is used, the enclosure numbering shown above may change or contain additional numbering. Refer to the *HP StorageWorks Enterprise Virtual Array hardware configuration guide* for more information.

For more information about the reporting group number, see [Viewing the Reporting Group Feature](#).

Enclosure address bus connections

Connecting the enclosures to the enclosure ID expansion cables establishes the enclosure address bus. The enclosures are automatically numbered based on the enclosure ID expansion cable to which they are connected. [Figure 20](#) shows the typical configuration of a 42U cabinet with 14 enclosures.

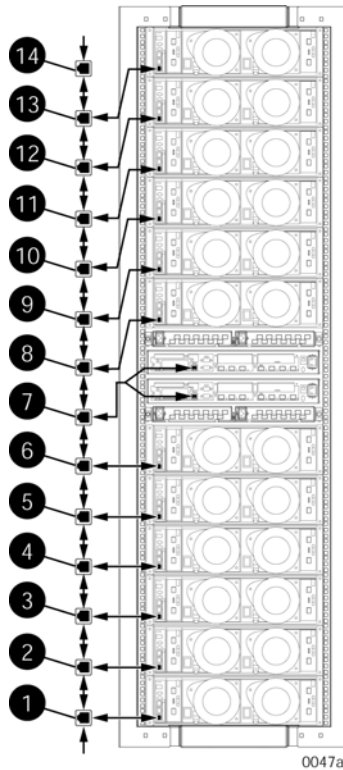

Figure 20 Enclosure address bus components with enclosure ID expansion cables

1. Shelf ID expansion cable port 1—Disk enclosure 1
2. Shelf ID expansion cable port 2—Disk enclosure 2
3. Shelf ID expansion cable port 3—Disk enclosure 3
4. Shelf ID expansion cable port 4—Disk enclosure 4
5. Shelf ID expansion cable port 5—Disk enclosure 5
6. Shelf ID expansion cable port 6—Disk enclosure 6
7. Shelf ID expansion cable port 7—Controller enclosures
8. Shelf ID expansion cable port 8—Disk enclosure 8
9. Shelf ID expansion cable port 9—Disk enclosure 9
10. Shelf ID expansion cable port 10—Disk enclosure 10
11. Shelf ID expansion cable port 11—Disk enclosure 11
12. Shelf ID expansion cable port 12—Disk enclosure 12
13. Shelf ID expansion cable port 13—Disk enclosure 13

Error Condition Reporting

The EMU constantly monitors enclosure operation and notifies you of conditions that could affect operation. When an error condition is detected, the following action is taken:

- The EMU alphanumeric display is changed to *Er*. A condition report has precedence over all other displays.
- The audible alarm sounds (if it is not disabled).
- The error is stored in the error queue.
- The error is passed to the controllers for processing and display by Command View EVA.

**NOTE:**

An error always generates a condition report. Not all condition reports are generated by errors.

Error condition categories

Each error condition is assigned to a category based on its impact on disk enclosure operation. The following four error categories are used:

- **Unrecoverable**—the most severe error condition, it occurs when one or more enclosure components have failed and have disabled some enclosure functions. The enclosure may be incapable of correcting, or bypassing the failure, and requires repairs to correct the error.

**NOTE:**

To maintain data integrity, corrective action should be implemented immediately for an **UNRECOVERABLE** condition.

- **Critical**—occurs when one or more enclosure components have failed or are operating outside of their specifications. The failures impact the normal operation of some components in the enclosure. Other components within the enclosure may be able to continue normal operations. Prompt corrective action should be taken to prevent system degradation.
- **Noncritical**—occurs when one or more components inside the enclosure have failed or are operating outside of their specifications. The failure of these components does not impact continued normal operation of the enclosure. All components in the enclosure continue to operate according to their specifications. The ability of the components to operate correctly may be reduced should other errors occur. Prompt corrective action should be taken to prevent system degradation.
- **Information**—the least severe condition indicates a condition exists that does not reduce the capability of a component. However, the condition can become an error and require corrective action. An **INFORMATION** condition provides an early warning, which enables you to prepare to implement corrective action before a component fails. Correction of the reported problem may be delayed.

The error conditions are prioritized by severity—from most severe to least. The most severe condition takes precedence and is reported first when multiple errors are detected. The reporting characteristics for each error condition are listed in [Table 17](#).

Table 17 Error condition reporting characteristics

Error condition	Takes precedence over	Audible alarm pattern ¹
UNRECOVERABLE	All other conditions	On continuously
CRITICAL	NONCRITICAL and INFORMATION	Sounds three times per alarm cycle
NONCRITICAL	INFORMATION	Sounds two times per alarm cycle
INFORMATION	No other conditions	Sounds once per alarm cycle

¹The pattern occurs when the condition is the most severe active condition

Error queue

The EMU maintains an internal error queue for storing error conditions. Each error condition remains in the error queue until the problem is corrected, or for at least 15 seconds after the error is reported. This ensures that when there are multiple errors or a recurring error, each can be displayed. Each entry in the error queue can be displayed using a combination of the top and bottom buttons. Each error entry in the queue contains the element type, the element number, and the error code.

Correcting the error removes the associated condition from the error queue. Replacing the EMU will also clear the error conditions. The order in which the EMU displays the error queue information is based on two factors:

- The severity of the error
- The time the error occurred

The most severe error in the queue always has precedence, regardless of how long less severe errors have been in the queue. This ensures that the most severe errors are displayed immediately.

 **NOTE:**

When viewing an error, the occurrence of a more severe error takes precedence and the display changes to the most severe error.

The earliest reported condition within an error type has precedence over errors reported later. For example, if errors at all levels have occurred, the EMU displays them in the following order:

1. UNRECOVERABLE errors in the sequence they occurred.
2. CRITICAL errors in the sequence they occurred.
3. NONCRITICAL errors in the sequence they occurred.
4. INFORMATION conditions in the sequence they occurred.

Error condition report format

Each EMU detected condition generates a condition report containing three pieces of information.

- **Element type** The first two-digit hexadecimal display defines the element type reporting the problem. The format for this display is *e.t.* with a period after each character. Valid element types are 0.1. through F.F.
- **Element number** The second display is a two-digit decimal number that defines the specific element reporting the problem. The format for this display is *en.* with a period after the second character.
- **Error code** The third display is a two-digit decimal number that defines the specific error code. The format for this display is *ec* without any periods.

For detailed information about each condition report, including recommended corrective actions.

Navigating the error condition display

When an error condition occurs, the alphanumeric display changes to *Er* and the error menu is active. The buttons are used to display the error condition values.

Perform the following procedure to display error conditions. [Figure 21](#) illustrates the sequence for displaying error conditions.

1. With *Er* in the display, press and hold the top push button until the first element type is displayed. The most severe error in the queue will be displayed.
2. Release the top push button when the element type is displayed. The element type has both decimal points lit.
3. Press and release the top push button to display the element number. This display has only the right decimal point lit.
4. Press and release the top push button again to display the error code. This display has no decimal points lit. Repeated press/release operations will cycle through these three values.
5. Press and hold the top push button from any of the three display states to move to the element type for the next error condition in the queue.
6. Use the top push button to display the values for the error condition.
7. When all error conditions have been displayed, press and release the bottom push button to return to the *Er* display.

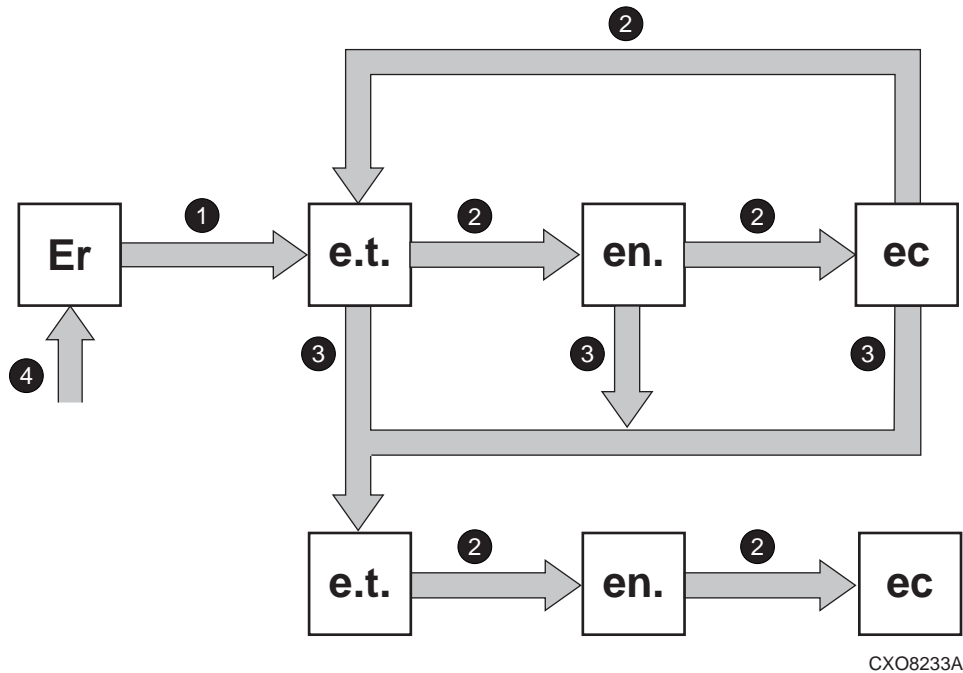

- 1 Press & hold top pushbutton to view first error in queue.
- 2 Press & release top pushbutton.
- 3 Press & hold top pushbutton to view next error.
- 4 Press and release the bottom pushbutton at any time to return to the Er display.

e.t. = element type, **en.** = element number, **ec** = error code

Figure 21 Displaying error condition values

Analyzing condition reports

Analyzing each error condition report involves three steps:

1. Identifying the element.
2. Determining the major problem.
3. Defining additional problem information.

Reporting group feature

Another function of the enclosure address bus is to provide communications within a reporting group. A Reporting Group (rG) is an HSV controller pair and the associated drive enclosures. The controller pair automatically assigns a unique (decimal) four-digit Reporting Group Number (RGN) to each EMU on a Fibre Channel drive enclosure.

Each of the drive enclosures on a loop pair are in one reporting group:

- All of the drive enclosures on loop pair 1, both loop 1A and loop 1B, share a unique reporting group number.
- All of the drive enclosures on loop pair 2, both loop 2A and loop 2B, share a unique reporting group number.

Each EMU collects environmental information from the associated enclosure and broadcasts the information to reporting group members using the enclosure address bus. Information from enclosures in other reporting groups is ignored.

Reporting group numbers

The reporting group number (RGN) range is 0000 through 4099, decimal.

- 0000 is reserved for enclosures that are not part of any reporting group.
- 0001 through 0015 are RGNs reserved for use by the EMU.
- 0016 through 4095 are valid RGNs.
- 4096 through 4099 are invalid RGNs.

The reporting group numbers are displayed on the EMU alphanumeric display as a pair of two-digit displays. These two displays are identified as *rH* and *rL*.

- Valid *rH* displays are in the range 00 through 40, and represent the high-order (most significant) two digits of the RGN.
- Valid *rL* displays are in the range 00 through 99, and represent the low-order (least significant) two digits of the RGN.

To view a reporting group number:

1. Press and release the bottom push button until the alphanumeric display is *rG*.
2. To display the two most significant digits of the Reporting Group Number, press and hold the top push button until the display is *rH*.
3. Press and release the top push button to display the first two digits of the RGN.
4. Press and release the top push button until the alphanumeric display is *rH*.
5. Press and hold the top push button until the alphanumeric display is *rL*.
6. Press and release the top push button to display the last two digits of the Reporting Group Number.
7. To exit the display, press and release the bottom push button until the alphanumeric display is *rG*.

Fibre Channel loop switches

The EVA8000 uses four loop switches to connect all of the drive enclosures to the controller pair using FC cables. The EVA 6000 includes two loop switches. Each switch acts as a central point of interconnection and establishes a fault-tolerant physical loop topology.

The half-rack form factor switch is controlled by firmware loaded into the on-board flash memory. The switch is designed as a central interconnect following the ANSI FC-AL standard. Disk enclosures are connected to the switch through Small Form-factor Pluggable (SFP) transceivers and cables.

The storage system uses one of the following loop switches:

- 30-10022-01 loop switch – used with 4 Gb controllers (requires XCS v5.110 or later)
- 30-10010-02 loop switch – used with 2 Gb and 4Gb controllers

30-10022-01 loop switch

The 30-10022-01 loop switch contains both system indicators and port indicators. The system indicators indicate the status of the switch, and the port indicators provide status of a specific port. [Figure 22](#) shows the 30-10022-01 loop switch with the system and port indicators.

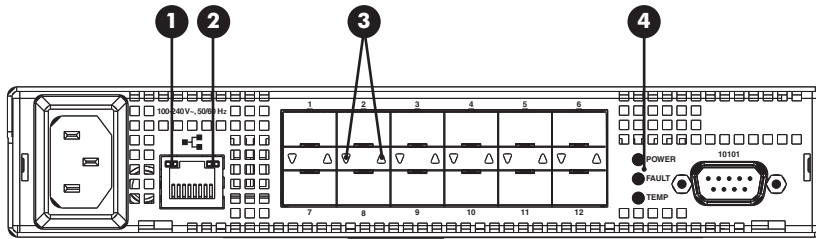

Figure 22 30-10022-01 loop switch status indicators

- | | |
|----------------------|---|
| 1. Ethernet activity | <ul style="list-style-type: none"> • Flashing - the Ethernet port is receiving data. • Flashing rapidly - the traffic level is high. |
| 2. Ethernet link | <ul style="list-style-type: none"> • On - the port is connected to an operational Ethernet. |
| 3. Port status | <ul style="list-style-type: none"> • Off - SFP is not installed in the port. • On (green) - Normal port operational status when an SFP is installed and a link has been established. • On (yellow) - port has an SFP installed but a link has not been established. • Flashing (green) - activity. Data is being transferred between the port and device. |
| 4. System status | |
| Power | <ul style="list-style-type: none"> • On - the switch is plugged in and the internal power supply is functional. |
| Fault | <ul style="list-style-type: none"> • On - an event has occurred that meets or exceeds the current Fault threshold setting. The default Fault threshold setting is critical. The switch will continue to operate. Switch functionality may be impaired depending on the event that triggered the Fault condition. Regardless of the cause, the switch requires immediate attention. |
| Temp | <ul style="list-style-type: none"> • On - the internal temperature has exceeded acceptable levels. The switch will continue to operate. Switch functionality may be impaired depending on the event that triggered the Temp condition. Regardless of the cause, the switch requires immediate attention. |

30-10010-02 loop switch

The 30-10010-02 loop switch contains both system indicators and port indicators. The system indicators indicate the status of the switch, and the port indicators provide status of a specific port. [Figure 23](#) shows the 30-10010-02 loop switch with the system and port indicators.

The Fibre Channel loop switch acts as a central point of interconnection and establishes a fault-tolerant physical loop topology between the controllers and the disk enclosures.

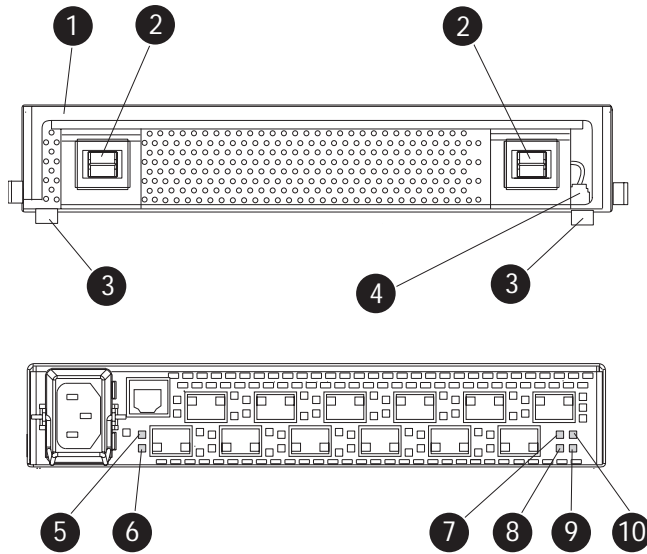

Figure 23 30-10010-02 loop switch status indicators

- | | |
|-------------------------|--------------------------------|
| 1. Handle | 2. Bezel snaps |
| 3. Alignment tabs | 4. Walk-up RS232 port |
| 5. SFP status indicator | 6. Port Bypassed indicator |
| 7. POST fault indicator | 8. Over Temp indicator |
| 9. Power indicator | 10. Loop operational indicator |

Power-on self test (POST)

When you power on the 30-10010-02 loop switch, it performs a Power-on Self Test (POST) to verify that the switch is functioning properly. During a POST, all of the indicators turn on for approximately two seconds. Then, turn off all of the indicators, except the power indicator.

If the Port Bypass indicators are blinking at a constant rate and the POST Fault indicator is on, the switch detected a fault during the POST. In this case, you need to contact your HP authorized service representative.

Reading the switch status indicators

Figure 23 shows the Fibre Channel switch with the system and port indicators. Table 18 lists and describes the system indicators.

Table 18 30-10010-02 loop switch status indicators

System indicator	Description
Power	A green indicator. When lit, this indicates that the switch is plugged in and the internal power is functional.
Loop operational	A green indicator. When lit, this indicates that the Fibre Channel loop has completed initialization and is now operational.
POST fault	An amber indicator. When lit, this indicates that the internal hardware self-test failed and the switch will not function.
OverTemp	An amber indicator. When lit, this indicates that the ambient temperature has exceeded 40° C. The switch is still functional; however you should correct the problem immediately. The Over temp indicator turns off when the problem is corrected.

Table 19 describes the port indicators.

Table 19 30-10010-02 loop switch port status indicators

SFP status indicator (Green)	Port bypass indicator (Amber)	Description
Off	Off	Indicates that the port does not have an SFP installed and is bypassed by the loop.
On	Off	Indicates that the port is operating normally. The port and device are fully operational.
On	On	Indicates the that port is in a bypassed state. The port is non-operational due to loss of signal, poor signal integrity, or the Loop Initialization Procedure (LIP). Note: This condition is also normal when the SFP is present but not attached to a Fibre Channel drive enclosure node or when the SFP is present and attached to only a cable assembly. Attaching the SFP to a device and plugging it into the port should initiate the LIP by the attached device.
Off	On	Indicates a Tx fault. The port is non-operational due to an SFP transmitter fault, improperly-seated SFP, or another failed device.

Problem isolation

Table 20 lists several basic problems and their solutions.

Table 20 30-10010-02 loop switch basic troubleshooting

Problem	Recommended action
SFPs are installed in ports but no indicators are lit.	<ol style="list-style-type: none"> 1. Verify that the power cord is firmly seated in the switch and is connected to the power outlet. 2. Check the power indicator to verify that the switch is on.
SFP is installed, but the Port Bypassed indicator is lit.	Re-seat the SFP. If the same condition occurs, the SFP is probably faulty and should be replaced.
SFP is installed, but the SFP status indicator and the Port Bypassed indicator are lit.	<p>This condition indicates that the switch is not receiving a valid Fibre Channel signal or that the switch is receiving an LIP.</p> <ol style="list-style-type: none"> 1. Ensure that the switch is powered on. 2. Contact your HP authorized service representative for further assistance.
SFP is installed and the SFP status indicator is lit, but the devices are not communicating.	<p>This condition indicates that the switch is receiving a valid Fibre Channel signal, but there are no upper level protocols active.</p> <ol style="list-style-type: none"> 1. Verify that you are running the correct firmware on all storage system hardware. 2. Check the Loop Operational indicator. <ol style="list-style-type: none"> a. If the Loop Operational indicator is lit, the devices have completed initialization. b. If the Loop Operational indicator is off, the devices were not initialized. Disconnect the devices from the switch. Reconnect the devices one at a time. This allows you to isolate the device that is responsible for the loop failure. 3. Contact your authorized service representative for further assistance.

HSV controllers

This section describes the major features, purpose, and function of the HSV210-A and HSV200-A controllers. Each Enterprise Virtual Array has a pair of these controllers. [Figure 24](#) shows the HSV210-A controller rear view. [Figure 25](#) shows the HSV200-A controller rear view. The front view of both controllers is shown in [Figure 26](#).

 **NOTE:**

The EVA4000-A/6000-A/8000-A uses controllers with 4 Gb host port capability. The 4 Gb controller can be distinguished from the earlier 2 Gb controllers by the “-A” suffix used on the controller bezel. The 4 Gb EVA4000/6000 controller is identified as the HSV200-A and the EVA8000 is identified as the HSV210-A.

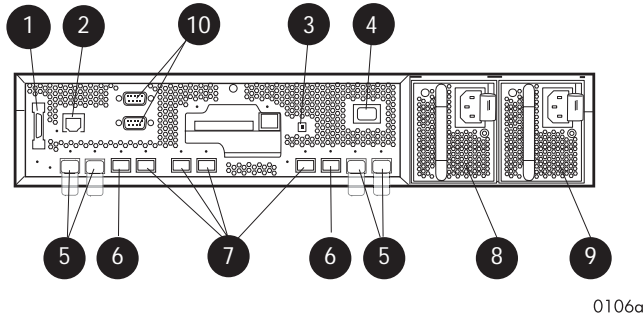

Figure 24 HSV210-A controller—rear view

- | | |
|---------------------------------|---|
| 1. Dual controller interconnect | 2. CAB (cabinet address bus) |
| 3. Unit ID | 4. Power ON |
| 5. FC device ports | 6. FC cache mirror ports |
| 7. FC host ports | 8. Power supply 0 |
| 9. Power supply 1 | 10. Service connectors (not for customer use) |

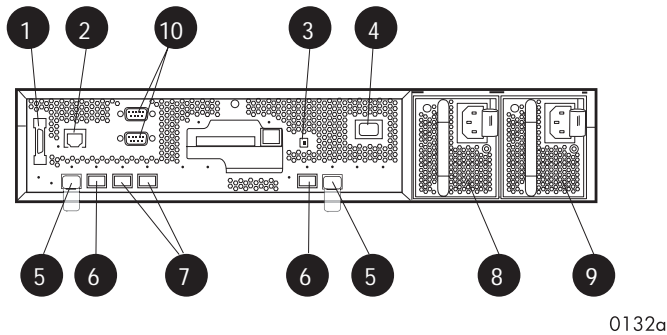

Figure 25 HSV200-A controller—rear view

- | | |
|---------------------------------|---|
| 1. Dual controller interconnect | 2. CAB (cabinet address bus) |
| 3. Unit ID | 4. Power ON |
| 5. FC device ports | 6. FC cache mirror ports |
| 7. FC host ports | 8. Power supply 0 |
| 9. Power supply 1 | 10. Service connectors (not for customer use) |

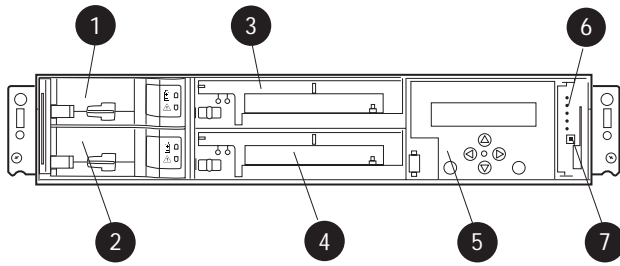

Figure 26 HSV controller—front view

- | | |
|---------------------------------|-----------------------------|
| 1. Battery 0 | 2. Battery 1 (EVA8000 only) |
| 3. Blower 0 | 4. Blower 1 |
| 5. Operator Control Panel (OCP) | 6. Status indicators |
| 7. Unit ID | |

High availability features

Two interconnected controllers ensure that the failure of a controller component does not disable the system. A single controller can fully support an entire system until the defective controller, or controller component, is repaired. For EVA8000 configurations with more than four disk drive enclosures, the complete data redundancy configuration includes two Loop A and two Loop B data paths. For EVA4000 and EVA6000 configurations, data redundancy is accomplished with two Loop A data paths.

Each HSV210-A controller has two lead-acid cache batteries that provide power to the cache memory. Each HSV200-A controller has one battery. When the batteries are fully charged, they can provide power to the cache for up to 96 hours.

Operator control panel

The operator control panel (OCP) provides a direct interface to each controller. From the OCP you can display storage system status and configuration information, shut down the storage system, and manage the password.

The OCP includes a 40-character LCD alphanumeric display, six pushbuttons, and five status indicators. See [Figure 27](#).

HP Command View EVA is the tool you will typically use to display storage system status and configuration information or perform the tasks available from the OCP. However, if HP Command View EVA is not available, the OCP can be used to perform these tasks.

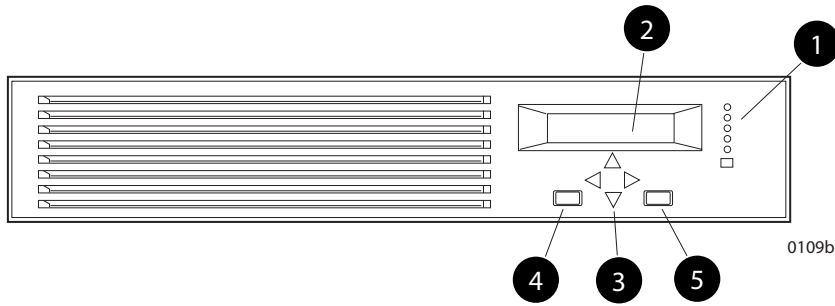

Figure 27 Controller OCP





1. Status indicators (see [Table 21](#)) and UID button
2. 40-character alphanumeric display
3. Left, right, top, and bottom push buttons
4. Esc
5. Enter

Status indicators

The status indicators display the operational status of the controller. The function of each indicator is described in [Table 21](#). During initial setup, the status indicators might not be fully operational.

The following sections define the alphanumeric displays modes, including the possible displays, the valid status indicator displays, and the push button functions.

Table 21 Controller status indicators

Indicator	Description
Fault 	When this indicator is on there is a controller problem. Check either HP Command View EVA or the LCD Fault Management displays for a definition of the problem and recommended corrective action.
Controller 	When this indicator is flashing slowly, a heartbeat, the controller is operating normally. When this indicator is not flashing, there is a problem.
Physical link to hosts established 	When this indicator is green, there is at least one physical link between the storage system and hosts that is active and functioning normally. When this indicator is off, there are no links between the storage system and hosts that are active and functioning normally.
Virtual disks presented to hosts 	When this indicator is green, all virtual disks that are presented to hosts are healthy and functioning normally. When this indicator is amber, at least one virtual disk is not functioning normally. When this indicator is off, there are no virtual disks presented to hosts and this indicates a problem with the Vdisk on the array.
Cache Battery Assembly 	When this indicator is off, the battery assembly is charged. When this indicator is on, the battery assembly is discharged.
Unit ID	Press to light the blue LED ID on the front and back of the controller. Also comes on in response to a Locate command issued by HP Command View EVA.

Each port on the rear of the controller has an associated status indicator located directly above it. [Table 22](#) lists the port and its status description.

Table 22 Controller port status indicators

Port	Description
Fibre Channel host ports	<ul style="list-style-type: none"> Green—Normal operation Amber—No signal detected Off—No SFP¹ detected or the Direct Connect OCP setting is incorrect
Fibre Channel device ports	<ul style="list-style-type: none"> Green—Normal operation Amber—No signal detected or the controller has failed the port Off—No SFP¹ detected
Fibre Channel cache mirror ports	<ul style="list-style-type: none"> Green—Normal operation Amber—No signal detected or the controller has failed the port Off—No SFP¹ detected
Dual controller interconnect port	<ul style="list-style-type: none"> Green—Normal operation Amber—Interconnect cable not connected

¹On copper Fibre Channel cables, the SFP is integrated into the cable connector.

Navigation buttons

The operation of the navigation buttons is determined by the current display and location in the menu structure. Table 23 defines the basic push button functions when navigating the menus and options.

To simplify presentation and to avoid confusion, the push button reference names, regardless of labels, are left, right, top, and bottom.

Table 23 Navigation button functions

Button	Function
▼	Moves down through the available menus and options
▲	Moves up through the available menus and options
▶	Selects the displayed menu or option.
◀	Returns to the previous menu.
Esc	Used for “No” selections and to return to the default display.
Enter	Used for “Yes” selections and to progress through menu items.

Alphanumeric display

The alphanumeric display uses two LCD rows, each capable of displaying up to 20 alphanumeric characters. By default, the alphanumeric display alternates between displaying the Storage System Name and the World Wide Name. An active (flashing) display, an error condition message, or a user entry (pressing a push button) overrides the default display. When none of these conditions exist, the default display returns after approximately 10 seconds.

Displaying the OCP menu tree

The Storage System Menu Tree lets you select information to be displayed, configuration settings to change, or procedures to implement. To enter the menu tree, press any navigation push button when the default display is active.

The menu tree is organized into the following major menus:

- System Info—displays information and configuration settings.

- Fault Management—displays fault information. Information about the Fault Management menu is included in [Controller fault management](#).
- Shutdown Options—initiates the procedure for shutting down the system in a logical, sequential manner. Using the shutdown procedures maintains data integrity and avoids the possibility of losing or corrupting data.
- System Password—create a system password to ensure that only authorized personnel can manage the storage system using HP Command View EVA.

To enter and navigate the storage system menu tree:

1. Press any push button while the default display is in view. System Information becomes the active display.
2. Press ▼ to sequence down through the menus.
Press ▲ to sequence up through the menus.
Press ► to select the displayed menu.
Press ◀ to return to the previous menu.



NOTE:

To exit any menu, press **Esc** or wait ten seconds for the OCP display to return to the default display.

[Table 24](#) identifies all the menu options available within the OCP display.

△ **CAUTION:**

Many of the configuration settings available through the OCP impact the operating characteristics of the storage system. You should not change any setting unless you understand how it will impact system operation. For more information on the OCP settings, contact your HP-authorized service representative.

Table 24 Menu options within the OCP display

System Information	Fault Management	Shutdown Options	System Password
Versions	Last Fault	Restart	Change Password
Host Port Config (Sets Fabric or Direct Connect)	Detail View	Power Off	Clear Password
Device Port Config (Enables/disables device ports)		Uninitialize System	Current Password (Set or not)
IO Module Config (Enables/disables auto-bypass)			
Loop Recovery Config (Enables/disables recoveries)			
Unbypass Devices			
UUID Unique Half			
Debug Flags			
Print Flags			
Mastership Status (Displays controller role — master or slave)			

Displaying system information



NOTE:

The purpose of this information is to assist the HP-authorized service representative when servicing your system.

The system information displays show the system configuration including the XCS version, the OCP firmware and application programming interface (API) versions, and the enclosure address bus programmable integrated circuit (PIC) configuration. You can only view, not change, this information.

Displaying versions system information

When you press ▼, the active display is Versions. From the Versions display you can determine the:

- OCP firmware version
- Controller version
- XCS version



NOTE:

The terms PPC, Sprite, Glue, SDC, CBIC, and Atlantis are for development purposes and have no significance for normal operation.

**NOTE:**

When viewing the software or firmware version information, pressing displays the Versions Menu tree.

To display System Information

1. The default display alternates between the Storage System Name display and the World Wide Name display.

Press any push button to display the Storage System Menu Tree.

2. Press until the desired Versions Menu option appears, and then press or to move to sub-menu items.

Shutting down the system

**CAUTION:**

To power off the system for more than 96 hours, use HP Command View EVA.

You can use the Shutdown System function to implement the shutdown methods listed below. These shutdown methods are explained in [Table 25](#).

- Shutting down the controller (see [Shutting the controller down](#)).
- Restarting the system (see [Restarting the System](#)).
- Uninitializing the system (see [Uninitializing the System](#)).

To ensure that you do not mistakenly activate a shutdown procedure, the default state is always NO, indicating *do not implement this procedure*. As a safeguard, implementing any shutdown method requires you to complete at least two actions.

Table 25 Shutdown methods

LCD prompt	Description
Restart System?	Implementing this procedure establishes communications between the storage system and HP Command View EVA. This procedure is used to restore the controller to an operational state where it can communicate with HP Command View EVA.
Power off system?	Implementing this procedure initiates the sequential removal of controller power. This ensures no data is lost. The reasons for implementing this procedure include replacing a drive enclosure.
Uninitialize?	Implementing this procedure will cause the loss of all data. For a detailed discussion of this procedure, see Uninitializing the System .

Shutting the controller down

Use the following procedure to access the *Shutdown System* display and execute a shutdown procedure.

**NOTE:**

HP Command View EVA is the preferred method for shutting down the controller. Shut down the controller from the OCP only if HP Command View EVA cannot communicate with the controller.

Shutting down the controller from the OCP removes power from the controller on which the procedure is performed only. To restore power, toggle the controller's power .

△ **CAUTION:**

If you decide NOT to power off while working in the Power Off menu, *Power Off System NO* must be displayed before you press **Esc**. This reduces the risk of accidentally powering down.

1. Press ▼ three times to scroll to the Shutdown Options menu.
2. Press ► to display *Restart*.
3. Press ▼ to scroll to **Power Off**.
4. Press ► to select **Power Off**.
5. *Power off system* is displayed. Press **Enter** to power off the system.

Restarting the system

To restore the controller to an operational state, use the following procedure to restart the system.

1. Press ▼ three times to scroll to the Shutdown Options menu.
2. Press ► to select **Restart**.
3. Press ► to display *Restart system?*.
4. Press **Enter** to go to Startup.

No user input is required. The system will automatically initiate the startup procedure and proceed to load the Storage System Name and World Wide Name information from the operational controller.

Uninitializing the system

Uninitializing the system is another way to shut down the system. This action causes the loss of all storage system data. Because HP Command View EVA cannot communicate with the disk drive enclosures, the stored data cannot be accessed.

△ **CAUTION:**

Uninitializing the system destroys all user data. The WWN will remain in the controller unless both controllers are powered off. The password will be lost. If the controllers remain powered on until you create another storage system (initialize via GUI), you will not have to re-enter the WWN.

Use the following procedure to uninitialize the system.

1. Press ▼ three times to scroll to the Shutdown Options menu.
2. Press ► to display *Restart*.
3. Press ▼ twice to display *Uninitialize System*.
4. Press ► to display *Uninitialize?*
5. Select **Yes** and press **Enter**. The system is now uninitialized.

Password options

The password entry options are:

- Entering a password during storage system initialization (see [Setting up an HSV210-series controller pair using the OCP](#)).
- Showing the current password.
- Changing a password (see [Changing a password](#)).

- Removing password protection (see [Clearing a password](#)).

Changing a password

For security reasons, you may need to change a storage system password. Your password must contain eight characters consisting of any combination of the uppercase letters A through Z and the lowercase letters a through z.

Use the following procedure to change the password.

NOTE:

Changing a system password on the controller requires changing the password on any HP Command View EVA with access to the storage system.

1. Select a unique, eight-character password.
2. From the default menus (Storage System Name or World Wide Name) displayed, press ▼ three times to display *System Password*.
3. Press ► to display *Change Password?*
4. Press **Enter** for yes.
The default password, AAAAAAAA, is displayed.
5. Press ▲ or ▼ to select the first character.
6. Press ► to accept this character and select the next character.
7. Repeat the process to enter the remaining password characters.
8. Press **Enter** to enter the password and return to the default display.

Clearing a password

Use the following procedure to remove storage system password protection.

NOTE:

Changing a system password on the controller requires changing the password on any HP Command View EVA with access to the storage system.

1. Press ▼ four times to scroll to the System Password menu.
2. Press ► to display *Change Password?*
3. Press ▼ to scroll to *Clear Password*.
4. Press ► to display *Clear Password*.
5. Press **Enter** to clear the password.
The *Password cleared* message will be displayed.

Setting up a controller pair using the OCP

For information about how to set up a controller pair during initial installation see [Setting Up a Controller Pair Using the OCP](#).

Power supplies

Two power supplies provide the necessary operating voltages to all controller enclosure components. If one power supply fails, the remaining supply is capable of operating the enclosure.

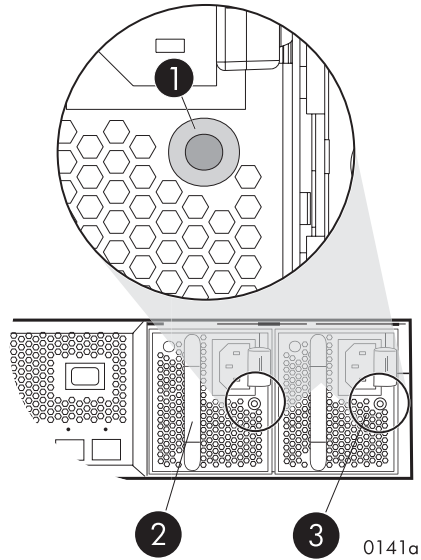

Figure 28 Power supplies

1. Status indicator
2. Power supply 0
3. Power supply 1

Table 26 Power supply status indicators

Status indicator	Description
Green	Normal operation
Amber	Power supply failure
Flashing amber	The power cord is disconnected from the power supply

Blowers

Two blowers provide the cooling necessary to maintain the proper operating temperature within the controller enclosure. If one blower fails, the remaining blower is capable of cooling the enclosure.

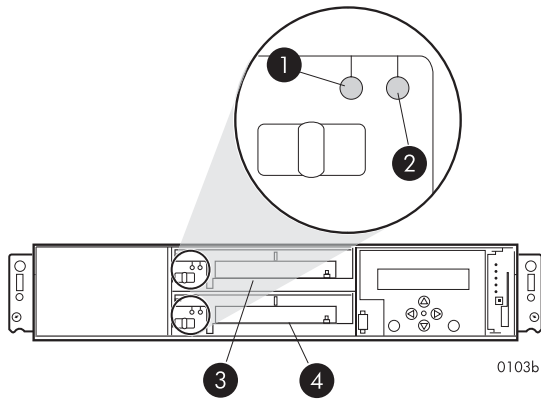

Figure 29 Blower

- 1. Status indicator
- 2. Fault indicator
- 3. Blower 0
- 4. Blower 1

Table 27 Blower status indicators

Status indicator	Fault indicator	Description
On	Off	Normal operation
Off	On	Blower failure

Cache battery

Batteries provide backup power to maintain the contents of the controller cache when AC power is lost and the storage system has not been shutdown properly. When fully charged the batteries can sustain the cache contents for to 96 hours. Two batteries are used on the EVA8000 and a single battery is used on the EVA6000 and EVA4000. [cache batteries](#) illustrates the location of the cache batteries and the battery status indicators. Refer to [Table 28](#) for additional information on the status indicators.

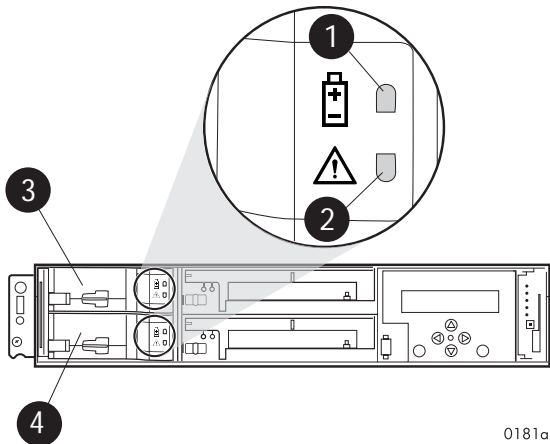

Figure 30 Cache batteries

- 1. Status indicator
- 2. Fault indicator
- 3. Battery 0
- 4. Battery 1

Table 28 Battery status indicators

Status indicator	Fault indicator	Description
On	Off	Normal operation. A maintenance charge process keeps the battery fully charged.
Flashing	Off	Battery is undergoing a full charging process. This is the indication you typically see after installing a new battery.
Off	On	Battery fault. The battery has failed and should be replaced.
Off	Flashing	The battery has experienced an over temperature fault
Flashing (fast)	Flashing (fast)	Battery code is being updated. When a new battery is installed, it may be necessary for the controllers to update the code on the battery to the correct version. Both indicators flash rapidly for approximately 30 seconds.
Flashing	Flashing	Battery is undergoing a scheduled battery load test, during which the battery is discharged and then recharged to ensure it is working properly. During the discharge cycle, you will see this display. The load test occurs infrequently and takes several hours.

HSV controller cabling

All data cables and power cables attach to the rear of the controller. Adjacent to each data connector is a two-colored link status indicator. [Table 22](#) identifies the status conditions presented by these indicators.

NOTE:

These indicators do not indicate whether there is communication on the link, only whether the link can transmit and receive data.

The data connections are the interfaces to the disk drive enclosures or loop es (depending on your configuration), the other controller, and the fabric. Fiber optic cables link the controllers to the fabric, and, if an expansion cabinet is part of the configuration, link the expansion cabinet drive enclosures to the loop es in the main cabinet. Copper cables are used between the controllers (mirror port) and between the controllers and the drive enclosures or loop es.

Racks

All storage system components are mounted in a rack. Each configuration includes two controller enclosures (the controller pair), drive enclosures, FC loop es (if required), and an expansion bulkhead. Each controller pair and all the associated drive enclosures form a single storage system.

Rack configurations

Each system configuration depends on the number of disk enclosures included in the storage system. For more information about racks and configurations, including expansion and interconnection, refer to the *HP StorageWorks Enterprise Virtual Array hardware configuration guide*.

Power distribution

AC power is distributed to the rack through a dual Power Distribution Unit (PDU) assembly mounted at the bottom rear of the rack. The characteristics of the fully-redundant rack power configuration are as follows:

- Each PDU is connected to a separate circuit breaker-protected, 30-A AC site power source (220–240 VAC ±10%, 50 or 60-Hz, ±5%). [Figure 31](#) illustrates the compatible 60-Hz and 50-Hz wall receptacles.



CXO7549A

NEMA L6-30R receptacle, 3-wire, 30-A, 60-Hz

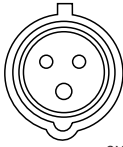

CXO5409B

IEC 309 receptacle, 3-wire, 30-A, 50-Hz

Figure 31 60-Hz and 50-Hz wall receptacles

- The standard power configuration for any Enterprise Virtual Array rack is the fully redundant configuration. Implementing this configuration requires:
 - Two separate circuit breaker-protected, 30-A site power sources with a compatible wall receptacle (see [Figure 31](#)).
 - One dual PDU assembly. Each PDU connects to a different wall receptacle.
 - Six Power Distribution Modules (PDM) per rack. Three PDMs mount vertically on each side of the rack. Each set of PDMs connects to a different PDU.
 - The drive enclosure power supplies on the left (PS 1) connect to the PDMs on the left with a gray, 66 cm (26 in) power cord.
 - The drive enclosure power supplies on the right (PS 2) connect to the PDMs on the right with a black, 66 cm (26 in) power cord.
 - The upper controller connects to a PDM on the left with a gray, 152 cm (60 in) power cord.
 - The lower controller connects to a PDM on the right with a black, 66 cm (26 in) power cord.



NOTE:

Drive enclosures, when purchased separately, include one 50 cm black cable and one 50 cm gray cable.

The configuration provides complete power redundancy and eliminates all single points of failure for both the AC and DC power distribution.

PDU's

Each Enterprise Virtual Array rack has either a 50- or 60-Hz, dual PDU mounted at the bottom rear of the rack. The 228481-002/228481-003 PDU placement is back-to-back, plugs facing down, with es on top.

- The standard 50-Hz PDU cable has an IEC 309, 3-wire, 30-A, 50-Hz connector.
- The standard 60-Hz PDU cable has a NEMA L6-30P, 3-wire, 30-A, 60-Hz connector.

If these connectors are not compatible with the site power distribution, you must replace the PDU power cord cable connector.

Each of the two PDU power cables has an AC power source specific connector. The circuit breaker-controlled PDU outputs are routed to a group of four AC receptacles (see [Figure 32](#)). The voltages are then routed to PDMs, sometimes referred to as AC power strips, mounted on the two vertical rails in the rear of the rack.

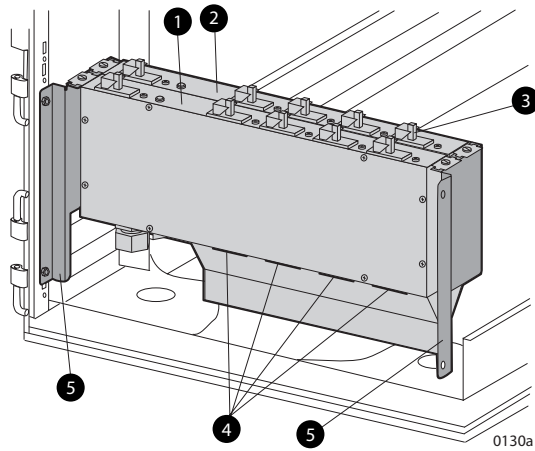

Figure 32 Dual PDU assembly

- | | |
|----------------------|-------------------|
| 1. PDU 1 | 2. PDU 2 |
| 3. Circuit breakers | 4. AC receptacles |
| 5. Mounting hardware | |

PDU 1

PDU 1 connects to AC power distribution source 1. A PDU 1 failure:

- Disables the power distribution circuit.
- Removes power from PDMs 1, 2, and 3.
- Disables PS 1 in the drive enclosures.
- Disables the upper controller power supply.

PDU 2

PDU 2 connects to AC power distribution source 2. A PDU 2 failure:

- Disables the power distribution circuit.
- Removes power from PDMs 4, 5, and 6.
- Disables PS 2 in the drive enclosures.
- Disables the lower controller power supply.

PDMs

There are six PDMs mounted in the rear of each rack:

- Three mounted on the left vertical rail connect to PDU 1.
- Three mounted on the right vertical rail connected to PDU 2.

Each PDM has eight AC receptacles and one thermal circuit breaker. The PDMs distribute the AC power from the PDUs to the enclosures. Two power sources exist for each controller pair and drive enclosure. If a PDU fails, the system will remain operational.

△ CAUTION:

The AC power distribution within a rack ensures a balanced load to each PDU and reduces the possibility of an overload condition. Changing the cabling to or from a PDM could cause an overload condition. HP supports only the AC power distributions defined in this user guide.

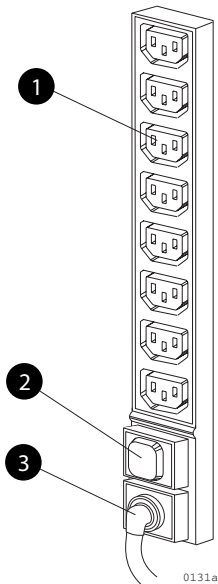

Figure 33 Rack PDM

1. Power receptacles
2. Thermal circuit breakers
3. AC power connector

Rack AC power distribution

The power distribution in an Enterprise Virtual Array rack is the same for all variants. The site AC input voltage is routed to the dual PDU assembly mounted in the rack lower rear. Each PDU distributes AC to a maximum of four PDMs mounted on the left and right vertical rails (see [Figure 34](#)).

- PDMs 1 through 3 connect to receptacles A through D on PDU 1. Power cords connect these PDMs to the number 1 drive enclosure power supplies and to the upper controller enclosure.
- PDMs 4 through 6 connect to receptacles A through D on PDU 2. Power cords connect these PDMs to the number 2 drive enclosure power supplies and to the lower controller enclosure.

 **NOTE:**

The locations of the PDUs and the PDMs are the same in all racks.

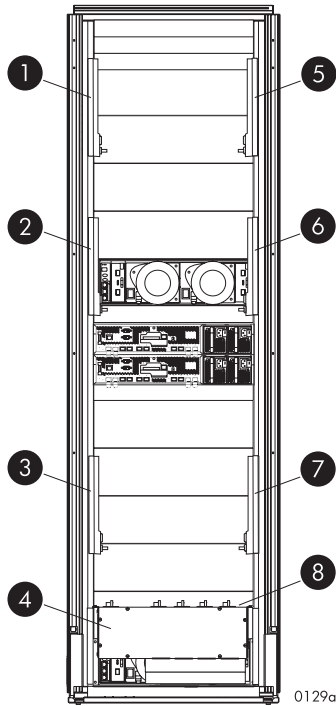

Figure 34 Rack AC power distribution

- | | |
|----------|----------|
| 1. PDM 1 | 2. PDM 2 |
| 3. PDM 3 | 4. PDU 1 |
| 5. PDM 4 | 6. PDM 5 |
| 7. PDM 6 | 8. PDU 2 |

Rack System/E power distribution components

AC power is distributed to the Rack System/E rack through Power Distribution Units (PDU) mounted on the two vertical rails in the rear of the rack. Up to four PDUs can be mounted in the rack—two mounted on the right side of the cabinet and two mounted on the left side.

Each of the PDU power cables has an AC power source specific connector. The circuit breaker-controlled PDU outputs are routed to a group of ten AC receptacles. The storage system components plug directly into the PDUs.

Rack AC power distribution

The power distribution configuration in a Rack System/E rack depends on the number of storage systems installed in the rack. If one storage system is installed, only two PDUs are required. If multiple storage systems are installed, four PDUs are required.

The site AC input voltage is routed to each PDU mounted in the rack. Each PDU distributes AC through ten receptacles directly to the storage system components.

- PDUs 1 and 3 (optional) are mounted on the left side of the cabinet. Power cords connect these PDUs to the number 1 drive enclosure power supplies and to the controller enclosures.
- PDUs 2 and 4 (optional) are mounted on the right side of the cabinet. Power cords connect these PDUs to the number 2 drive enclosure power supplies and to the controller enclosures.

Moving and stabilizing a rack

⚠ WARNING!

The physical size and weight of the rack requires a minimum of two people to move. If one person tries to move the rack, injury may occur.

To ensure stability of the rack, always push on the lower half of the rack. Be especially careful when moving the rack over any bump (e.g., door sills, ramp edges, carpet edges, or elevator openings). When the rack is moved over a bump, there is a potential for it to tip over.

Moving the rack requires a clear, uncarpeted pathway that is at least 80 cm (31.5 in) wide for the 60.3 cm (23.7 in) wide, 42U rack. A vertical clearance of 203.2 cm (80 in) should ensure sufficient clearance for the 200 cm (78.7 in) high, 42U rack.

⚠ CAUTION:

Ensure that no vertical or horizontal restrictions exist that would prevent rack movement without damaging the rack.

Make sure that all four leveler feet are in the fully raised position. This process will ensure that the casters support the rack weight and the feet do not impede movement.

Each rack requires an area 600 mm (23.62 in) wide and 1000 mm (39.37 in) deep (see [Figure 35](#)).

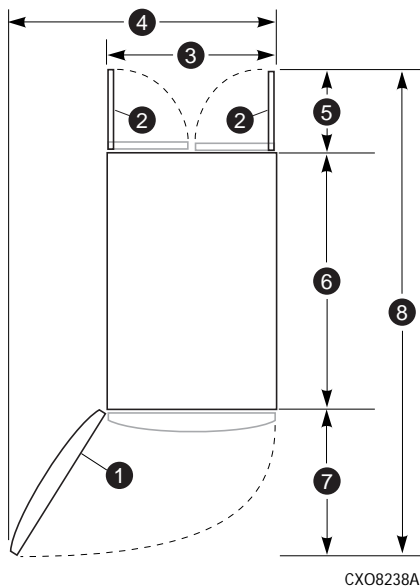
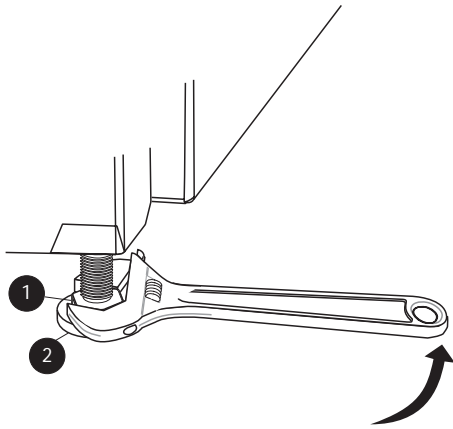

Figure 35 Single rack configuration floor space requirements

- | | |
|------------------------------------|------------------------------|
| 1. Front door | 2. Rear door |
| 3. Rack width 600 mm | 4. Service area width 813 mm |
| 5. Rear service area depth 300 mm | 6. Rack depth 1000 mm |
| 7. Front service area depth 406 mm | 8. Total rack depth 1706 mm |

If the feet are not fully raised, complete the following procedure:

1. Raise one foot by turning the leveler foot hex nut counterclockwise until the weight of the rack is fully on the caster (see [Figure 36](#)).
2. Repeat [Step 1](#) for the other feet.



CX07589A

Figure 36 Raising a leveler foot

1. Hex nut
 2. Leveler foot
 3. Carefully move the rack to the installation area and position it to provide the necessary service areas (see [Figure 35](#)).
- To stabilize the rack when it is in the final installation location:
1. Use a wrench to lower the foot by turning the leveler foot hex nut clockwise until the caster does not touch the floor. Repeat for the other feet.
 2. After lowering the feet, check the rack to ensure it is stable and level.
 3. Adjust the feet as necessary to ensure the rack is stable and level.

5 Customer replaceable units

This chapter describes the procedures for replacing CRUs. Information about initial enclosure installation, ESD protection, and common replacement procedures is also presented.

Customer self repair (CSR)

HP products are designed with many Customer Self Repair (CSR) parts to minimize repair time and allow for greater flexibility in performing defective parts replacement. If during the diagnosis period HP (or HP service providers or service partners) identifies that the repair can be accomplished by the use of a CSR part, HP will ship that part directly to you for replacement. There are two categories of CSR parts:

- **Mandatory**—Parts for which customer self repair is mandatory. If you request HP to replace these parts, you will be charged for the travel and labor costs of this service.
- **Optional**—Parts for which customer self repair is optional. These parts are also designed for customer self repair. If, however, you require that HP replace them for you, there may or may not be additional charges, depending on the type of warranty service designated for your product.



NOTE:

Some HP parts are not designed for customer self repair. In order to satisfy the customer warranty, HP requires that an authorized service provider replace the part. These parts are identified as “No” in [Table 29](#).

[Table 29](#) identifies which hardware components are customer replaceable. The WEBES fault management and diagnostics tool has been designed to identify many of the storage system component failures that may qualify for customer self repair. Using WEBES, ISEE or other diagnostic tools, a support specialist will work with you to diagnose and assess whether a replacement component is required to address a system problem. The specialist will also help you determine whether you can perform the replacement.

Based on availability and where geography permits, standard HP CSR part delivery is next business day. Same business day delivery options, available to EVA customers as local stocking and geography permits, may be discussed with your support specialist.

Replacement instructions are included in this user guide, in spare kits and at hp.com. If further assistance is required, you can call the HP Technical Support Center and a support specialist will help you over the phone.

HP specifies in the materials shipped with a replacement CSR part whether a defective part must be returned to HP. In cases where it is required to return the defective part to HP, you must ship the defective part back to HP within a defined period of time, normally five (5) business days. The defective part must be returned with the associated documentation in the provided shipping material. Failure to return the defective part may result in HP billing you for the replacement. With a customer self repair, HP will pay all shipping and part return costs and determine the courier/carrier to be used.

For more information about HP’s Customer Self Repair program, contact your local service provider. For the North American program, refer to the HP website (<http://www.hp.com/go/selfrepair>).

CSR is available for most HP products currently under warranty. For more information on warranty service go to: <http://h18006.www1.hp.com/products/storageworks/warranty.html>

Parts only warranty service

Your HP Limited Warranty may include a parts only warranty service. Under the terms of parts only warranty service, HP will provide replacement parts free of charge.

For parts only warranty service, CSR part replacement is mandatory. If you request HP to replace these parts, you will be charged for the travel and labor costs of this service.

Best practices for replacing hardware components

The following information will help you replace the hardware components on your storage system successfully. Follow these tips any time you must replace a component.

△ CAUTION:

Removing a component significantly changes the air flow within the enclosure. All components must be installed for the enclosure to cool properly. If a component fails, leave it in place in the enclosure until a new component is available to install.

Component replacement videos

To assist you in replacing the components, videos have been produced of the procedures. You can view the videos at the following web site.

<http://www.thesml.com/csr.htm?prodSeriesId=470490>

Verifying component failure

- Make sure you confer with HP technical support to verify that the hardware component has failed and that you are authorized to replace it yourself.
- Additional hardware failures can complicate component replacement. Check HP StorageWorks Command View EVA and/or the WEBES System Event Analyzer as follows to detect any additional hardware problems:
 - When you have confirmed that a component replacement is required, you may want to clear the Real Time Monitoring view. This makes it easier to identify additional hardware problems that may occur while waiting for the replacement part.
 - Before installing the replacement part, check the Real Time Monitoring view for any new hardware problems. If additional hardware problems have occurred, contact HP support before replacing the component.
 - Refer to the System Event Analyzer online help for additional information.

Procuring the spare part

- [Table 29](#) lists the parts that qualify for CSR, including assembly and spare numbers. Parts have a nine-character spare component number on their label ([Figure 37](#)). The first six characters (123479) identify the element; the last three characters (002) define the revision level. The replacement component revision level must be the same as, or greater than, the number on the element being replaced. The higher the revision level, the later the revision.



8053A-ST

Figure 37 Typical product label

- The spare part number for each disk drive is listed on the capacity label attached to each drive. See [Figure 38](#).



Figure 38 Disk drive label

Table 29 Hardware component CSR support

Part description	Assembly part number	Spare part number	Customer self repair ¹
Cache battery	30-10013-01	348879-001 (30-10013-S1)	Optional
Controller blower	12-10008-01	390852-001 (12-10008-S1)	Optional
Controller power supply	339596-001	349800-001	Optional ²
Disk enclosure blower	70-40085-01	123482-001(70-40085-S1)	Optional ²
Disk enclosure power supply	30-50872-XXXX=01, 02, 03, 12, 13	212398-001(30-50872-S1 or -S2)	Optional ²
Disk drive – 500 GB FATA	370792-001	371142-001	Optional
Disk drive – 400 GB FATA	382242-001	382262-001	Optional
Disk drive – 300 GB 10K	365608-001	366023-001	Optional
Disk drive – 250 GB FATA	365606-001	366022-001	Optional
Disk drive – 146 GB 10K	293557-001	300590-001	Optional
Disk drive – 146 GB 15K	365610-001	366024-001	Optional
Disk drive – 72 GB 10K	238926-001	244448-001	Optional
Disk drive – 72 GB 15K	293569-001	300588-001	Optional
Operator control panel	70-41143-01	390859-001(70-41143-S1)	No
EMU	70-40145-02	375393-001(70-40145-S2)	No
FC I/O module A	70-40616-03	364549-001(70-40616-S4)	No
FC I/O module B	70-40615-03	364548-001(70-40615-S4)	No
2GB SFP Transceiver	212192-002	229204-001	No
Controller EVA8000	70-41138-01	390855-001(70-41138-S1)	No
Controller EVA6000/4000	70-41138-02	390856-001(70-41138-S2)	No
Front panel bezel EVA8000	70-41140-01	390853-001(70-41140-S1)	Optional
Front panel bezel EVA6000/4000	70-41140-02	390854-001(70-41140-S2)	Optional

¹Mandatory—Parts for which customer self repair is mandatory. If you request HP to replace these parts, you will be charged for the travel and labor costs of this service.

Optional—Parts for which customer self repair is optional. These parts are also designed for customer self repair. If, however, you require that HP replace them for you, this may be done at no additional charge under the type of warranty service designated for your product.

No—Parts for which customer self repair is not available. These parts are not designed for customer self repair. In order to satisfy the customer warranty, HP requires that an authorized service provider replace the part.

² Always use caution to avoid damage to cabling when replacing this component.

Replacing the failed component

△ CAUTION:

Components can be damaged by electrostatic discharge. Use proper anti-static protection as discussed below..

- Always transport and store CRUs in an ESD protective enclosure.
 - Do not remove the CRU from the ESD protective enclosure until you are ready to install it.
 - Always use ESD precautions, such as a wrist strap, heel straps on conductive flooring, and an ESD protective smock when handling ESD sensitive equipment.
 - Avoid touching the CRU connector pins, leads, or circuitry.
 - Do not place ESD generating material such as paper or non anti-static (pink) plastic in an ESD protective enclosure with ESD sensitive equipment.
-

- HP recommends waiting until periods of low storage system activity to replace a component.
- When replacing components at the rear of the rack, cabling may obstruct access to the component. Carefully move any cables out of the way to avoid loosening any connections. In particular, avoid cable damage that may be caused by:
 - Kinking or bending.
 - Disconnecting cables without capping. If uncapped, cable performance may be impaired by contact with dust, metal or other surfaces.
 - Placing removed cables on the floor or other surfaces, where they may be walked on or otherwise compressed.
- Replacement procedures are provided with each component. You can also download the replacement instructions in Dutch, English, French, German, Italian, Spanish and Japanese from the following web sites:
 - <http://www.hp.com/go/eva4000>
 - <http://www.hp.com/go/eva6000>
 - <http://www.hp.com/go/eva8000>

From any of these web sites, select **Technical documents** under Product information for additional information.

Returning the defective part

- HP specifies, in the materials shipped with a replacement CSR part, whether the defective component must be returned to HP. Where required, you must ship the defective component back to HP within a defined period of time, normally five (5) business days. The defective component must be returned with the associated documentation provided in the shipping material. Failure to return the defective component may result in HP billing you for the replacement. With a customer self repair, HP will pay all shipping and component return costs and determine the courier/carrier to be used.

Replacing the cache battery

This section describes the procedure for replacing the cache battery used in Enterprise Virtual Array (EVA) products.

△ CAUTION:

When running XCS v5.030, v5.031, v5100. or v5.110 it is necessary to shutdown the controller when replacing a battery. Contact your HP-authorized service representative for assistance when replacing a cache battery on these versions of XCS.

**NOTE:**

There are two cache batteries installed in the EVA8000 controller enclosure in slots 0 and 1 at the left end of the enclosure. There is only one battery in the EVA4000 and EVA6000 controller installed in the upper slot (0).

Before you begin

Observe the following precautions when replacing a battery.

△ CAUTION:

Parts can be damaged by electrostatic discharge. Use proper anti-static protection. Refer to the documentation that shipped with your system for additional information.

Use two hands when removing a battery to ensure you do not drop it.

Have a copy of the product User Guide available for reference. You can download a copy of the user guide from the product support page on the HP web site.

Verifying component failure

Before replacing a battery, use the following methods to verify the component failure:

△ CAUTION:

If Command View EVA does not present a status consistent with that of the battery status indicator, or if Command View or the System Event Analyzer indicates multiple hardware failures, contact HP support for assistance. The HP support web site is located at <http://www.hp.com/support>

- Analyze any failure messages you may have received from system monitoring (System Event Analyzer).
- Check status using Command View EVA:

△ CAUTION:

If you are running HP StorageWorks Command View EVA 4.0, the battery numbering presented in the management interface is inconsistent with the numbering used in the storage system and reported by the ISEE/WEBES monitoring tool. HP Command View EVA 4.0 identifies the top battery as 1 and the bottom battery as 2. The correct numbering should be 0 and 1 respectively. Remember to make this conversion when replacing a battery. This inconsistency is corrected in later versions of HP Command View EVA.

1. In the Navigation pane, select **Storage system > Hardware > Rack > Controller enclosure > Controller**.
 2. In the Content pane, select the **Enclosure** tab. The status is displayed in the **Cache Battery Modules** field. The status should be Failed .
 3. To help identify the correct enclosure, click **Locate > Locate On** to display **Locate Confirmed** on the controller operator control panel (OCP). The blue Unit ID indicator will also turn on.
- Check the battery status indicators. See [Figure 39](#). The battery fault indicator should be on. To view the status indicators it is necessary to remove the front panel as described in [Removing a blower](#).

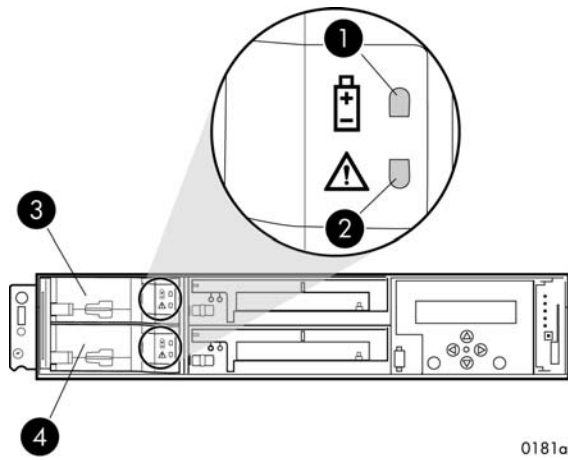

0181a

Figure 39 Battery status indicators

- | | |
|---------------------|--------------------|
| 1. Status indicator | 2. Fault indicator |
| 3. Battery 0 | 4. Battery 1 |

Removing a battery

1. Remove the front panel (1, [Removing a battery](#)) by grasping the panel at each end pulling it off the enclosure.
2. While moving the battery mounting latch (2, [Removing a battery](#)) to the right, pull the battery out of the enclosure (3). Support the battery with both hands as it is removed.

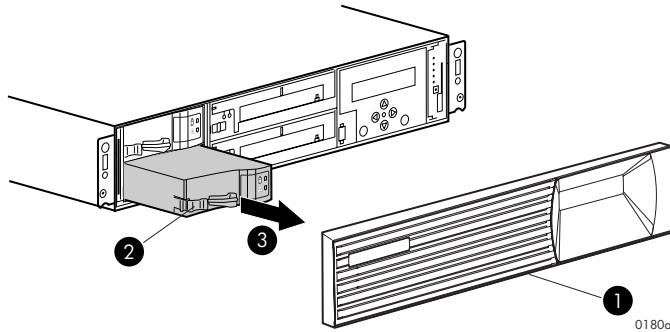

0180a

Figure 40 Removing a battery

Installing a battery

- Position the battery as high in the slot as possible, then slide the battery into the enclosure (1, [Figure 41](#)) until it is fully seated and the mounting latch engages (2).

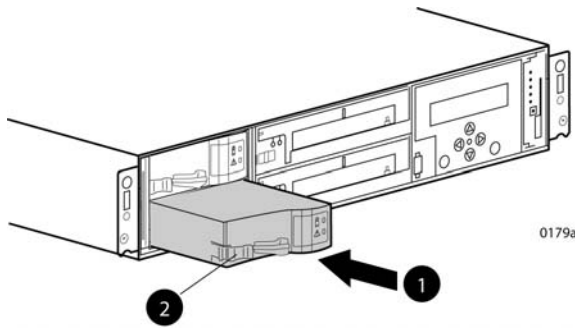

Figure 41 Installing a battery

Verifying proper operation

After replacing the battery, check the following to verify that the component is operating properly:

NOTE:

It may take up to 10 minutes for the component to display good status.

- Check the battery status indicators. See [Table 28](#)
 - During the first minute, both status indicators may be on or flashing.
 - The status indicator (1) should then begin flashing, indicating the battery is charging. It may take several hours for a new battery to fully charge. The fault indicator (2) should be off during charging.

After checking the status indicator, install the front panel on the enclosure by pressing it firmly into place.

- From Command View EVA
 - Navigate back to the component and check the status. It should be .
 - Turn off the locate function by clicking **Locate > Locate Off**

Replacing a controller blower

This section describes the procedure for replacing the blower used in Enterprise Virtual Array (EVA) products.

Before you begin

Observe the following precautions when replacing a blower.

CAUTION:

Removing a blower significantly changes the air flow within the enclosure. Both blowers must be installed for the enclosure to cool properly. If a blower fails, leave it in place in the enclosure until a new blower is available to install.

Parts can be damaged by electrostatic discharge. Use proper anti-static protection. Refer to the documentation that shipped with your system for additional information.

Have a copy of the product User Guide available for reference. You can download a copy of the User Guide from the product support page on the HP web site.

Verifying component failure

Before replacing a blower, use the following methods to verify the component failure:

△ **CAUTION:**

If Command View EVA does not present a status consistent with that of the blower status indicators, or if Command View or the System Event Analyzer indicates multiple hardware failures, contact HP support for assistance. The HP support web site is located at <http://www.hp.com/support>

- Analyze any failure messages you may have received from system monitoring (System Event Analyzer).
- Check status using Command View EVA:

△ **CAUTION:**

If you are running HP StorageWorks Command View EVA 4.0, the blower numbering presented in the management interface is inconsistent with the numbering used in the storage system and reported by the ISEE/WEBES monitoring tool. HP Command View EVA 4.0 identifies the top blower as 1 and the bottom blower as 2. The correct numbering should be 0 and 1 respectively. Remember to make this conversion when replacing a blower. This inconsistency is corrected in later versions of HP Command View EVA.

1. In the Navigation pane, select **Storage system > Hardware > Rack > Controller enclosure > Controller**
 2. In the Content pane, select the **Enclosure** tab. The status is displayed in the **Cooling System** field. The status should be Failed .
 3. To help identify the correct enclosure, click **Locate > Locate On** to display **Locate Confirmed** on the controller operator control panel (OCP). The blue Unit ID indicator will also turn on.
- Check the blower status indicators. See [Figure 42](#). The fault indicator (2) should be on. To view the status indicators it may be necessary to remove the front panel as described in [Removing a blower](#).

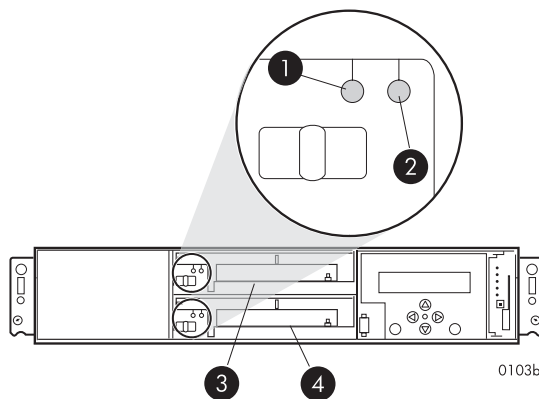

Figure 42 Blower status indicators

- | | |
|---------------------|--------------------|
| 1. Status indicator | 2. Fault indicator |
| 3. Blower 0 | 4. Blower 1 |

Removing a blower

△ **WARNING!**

The blower motor does not stop immediately when the blower is removed. Keep your fingers away from the blower blades until the motor stops.

1. Remove the front panel (1) by grasping the panel at each end pulling it off the enclosure.
2. Move the wine-colored mounting latch (2) to the right, and pull the blower out of the enclosure (3).

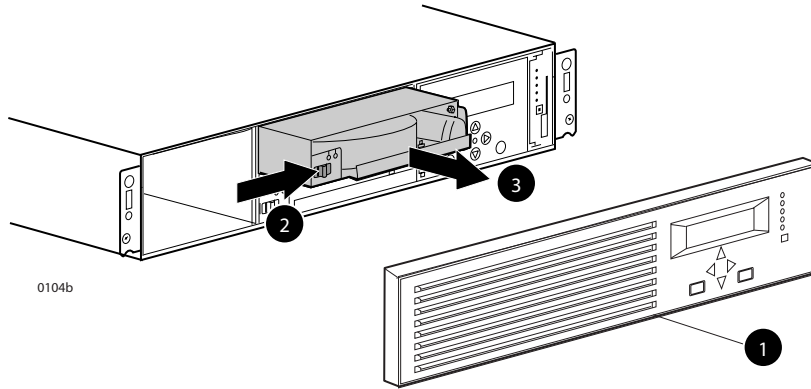

Figure 43 Removing a blower

Installing a blower

- Position the blower as high in the slot as possible, then slide the blower into the enclosure (1) until the mounting latch (2) engages.

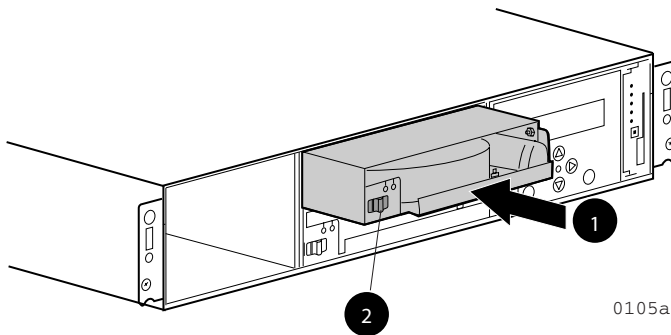

Figure 44 Installing a blower

Verifying proper operation

After replacing the blower, check the following to verify that the component is operating properly:

- Blower should begin operating immediately.
- Check the controller blower status indicators. See [Figure 42](#)
 - The status indicator (1) should be on.
 - The fault indicator (2) should be off.

After checking the status indicator, install the front panel on the enclosure by pressing it firmly into place. Also clear the locate message on the OCP by pressing the ESC push button.

- From Command View EVA
 - Navigate back to the component and check the status. It should be .
 - Turn off the locate function by clicking **Locate > Locate Off**

Returning the failed component

Please follow the return instructions provided with the new component.

Replacing the controller power supply

This section describes the procedure for replacing the power supply used in EVA 4000/6000/8000 products.

NOTE:

Because this component is used in several products, the drawings may reflect a different enclosure than the one you have. The removal and replacement procedure is the same for each product.

Before you begin

Observe the following precautions when replacing a power supply.

△ CAUTION:

Removing a power supply significantly changes the air flow within the enclosure. Both power supplies must be installed for the enclosure to cool properly. If a power supply fails, leave it in place in the enclosure until a new power supply is available to install.

If cabling is obstructing access to the power supply, carefully move the cables out of the way to avoid loosening any connections.

Parts can be damaged by electrostatic discharge. Use proper anti-static protection. Refer to the documentation that shipped with your system for additional information.

Have a copy of the product User Guide available for reference. You can download a copy of the User Guide from the product support page on the HP web site.

Verifying component failure

Before replacing a power supply, use the following methods to verify the component failure.

△ CAUTION:

If Command View EVA does not present a status consistent with that of the power supply status indicator, or if Command View or the System Event Analyzer indicates multiple hardware failures, contact HP support for assistance. The HP support web site is located at <http://www.hp.com/support>

- Analyze any failure messages you may have received from system monitoring (System Event Analyzer).
- Check status using Command View EVA:

△ CAUTION:

If you are running HP StorageWorks Command View EVA 4.0, the power supply numbering presented in the management interface is inconsistent with the numbering used in the storage system and reported by the ISEE/WEBES monitoring tool. HP Command View EVA 4.0 identifies the left power supply as 1 and the right power supply as 2. The correct numbering should be 0 and 1 respectively. Remember to make this conversion when replacing a power supply. This inconsistency is corrected in later versions of HP Command View EVA.

1. In the Navigation pane, select **Storage system > Hardware > Rack > Controller enclosure > Controller**
2. In the Content pane, select the **Enclosure** tab. The status is displayed in the **Power System** field. The status should be Failed .

3. To help identify the correct enclosure, click **Locate > Locate On** to display **Locate Confirmed** on the controller operator control panel (OCP). The blue Unit ID indicator will also turn on.
- Check the power supply status indicator. See [Figure 45](#). It should be amber or off.

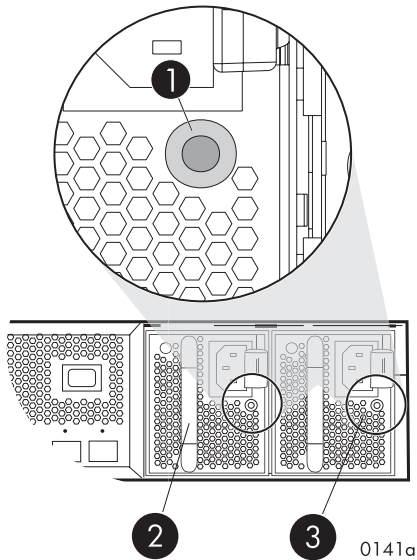

Figure 45 Power supply status indicator

- | | |
|---------------------|-------------------|
| 1. Status indicator | 2. Power supply 0 |
| 3. Power supply 1 | |

Removing a power supply

1. Disconnect the AC power cord from the power supply.
2. While moving the wine-colored latch to the left (1, [Removing a power supply](#)), grasp the handle and pull the power supply out of the enclosure (2).

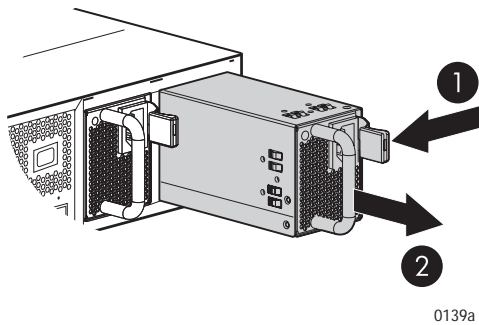
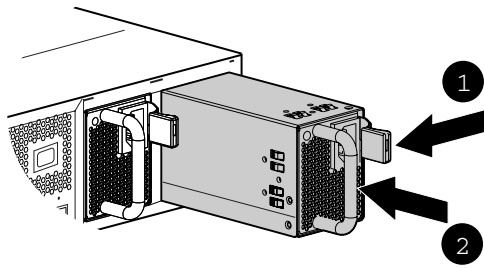

Figure 46 Removing a power supply

Installing a power supply

1. Remove any connector protector that may be covering the AC power connector on the new power supply.
2. While pressing in on the mounting latch (1, [Installing a power supply](#)), slide the power supply into the enclosure until it is fully seated (2).
3. Connect the AC power cord to the power supply.



0138a

Figure 47 Installing a power supply

Verifying proper operation

After replacing the power supply, check the following to verify that the component is operating properly:

- Check the power supply status indicator. It should be green.
- Navigate back to the component and check the status. It should be .
- Turn off the locate function by clicking **Locate > Locate Off**

Returning the failed component

Please follow the return instructions provided with the new component.

Replacing a disk drive

This section describes the procedure for replacing a Fibre Channel disk drive.

Before you begin

Observe the following precautions when replacing the disk drive.

△ CAUTION:

Make sure you have a replacement part available before removing the failed component. Removing a component impacts cooling within the enclosure.

Do not remove more than one disk drive at a time from the enclosure. Doing so will impact cooling of the enclosure and may cause data loss.

Parts can be damaged by electrostatic discharge. Use proper anti-static protection. Refer to the documentation that shipped with your system for additional information.

Have a copy of the product User Guide available for reference. You can download a copy of the User Guide from the product support page on the HP web site.

Verifying component failure

Before beginning the replacement procedure, use the following methods to verify the component failure.

△ CAUTION:

If Command View EVA does not present a status consistent with that of the disk drive status indicators, or if Command View or the System Event Analyzer indicates multiple hardware failures, contact HP support for assistance. The HP support web site is located at <http://www.hp.com/support>

- Analyze any failure messages you may have received from system monitoring (System Event Analyzer).
- Check the disk drive status indicators. See [Figure 48](#). The Fault indicator should be On.
- Check status using Command View EVA:
 1. In the Navigation pane, select **Storage system > Hardware > Rack > Disk enclosure > Bay**
 2. In the Content pane, select the **Disk Drive** tab. The Operational state should be  Failed.
 3. Verify the following status conditions are met before proceeding:
 - Migration state - Not migrating
 - Requested usage - Ungrouped
 - Actual usage - Ungrouped
 4. Click **Remove** to prepare the disk for removal. The status indicators on the disk drive will begin flashing to help you locate the disk.

 **NOTE:**

Certain disk drive failures result in a status of *Drive unmated*, and disable the **Remove** button. In this situation, the disk drive can be immediately removed from the enclosure. The fault indicator will be on to help locate the failed disk drive.

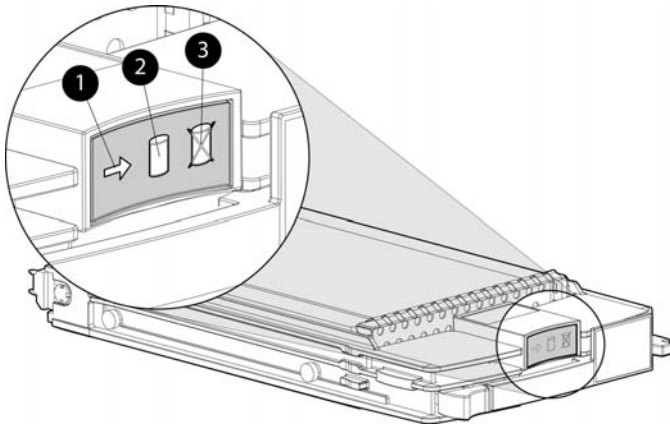

1. Activity
2. Online
3. Fault

Figure 48 Disk drive status indicators

Removing a disk

 **CAUTION:**

Rotating media can make the disk drive difficult to handle. To avoid dropping and damaging the disk drive, wait approximately 30 seconds for the media to stop rotating before removing the drive from the enclosure.

1. Push in the wine-colored ejector push button (1, [Figure 49](#)) and pull the release lever (2) down to the full open position.
2. Pull the disk drive part way out of the enclosure (3) and wait for the media to stop spinning.
3. When the media has stopped spinning, remove the disk drive from the enclosure.

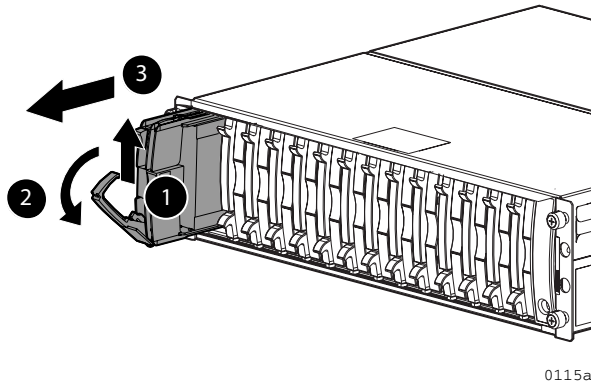

0115a

Figure 49 Removing a disk drive

Changing the Device Addition Policy

To prevent the storage system from automatically grouping a new disk drive that may have the incorrect firmware on it, the Device Addition Policy must be checked and set to manual if necessary:

1. In the Command View Navigation pane, select the storage system.
The Initialized Storage System Properties window opens.
2. Click **System Options**
3. Select **Set system operational policies**
4. If the Device Addition Policy is set to **Automatic**, change it to **Manual**
5. Click **Save changes**

Installing a disk drive

1. Push in the ejector push button on the disk drive and pull the release lever down to the full open position.
2. Insert the drive into the enclosure as far as it will go (1, [Figure 50](#)).
3. Close the release lever until it engages the ejector push button, and the disk drive seats in the backplane (2).
4. Press in firmly on the disk drive to ensure it is seated properly.

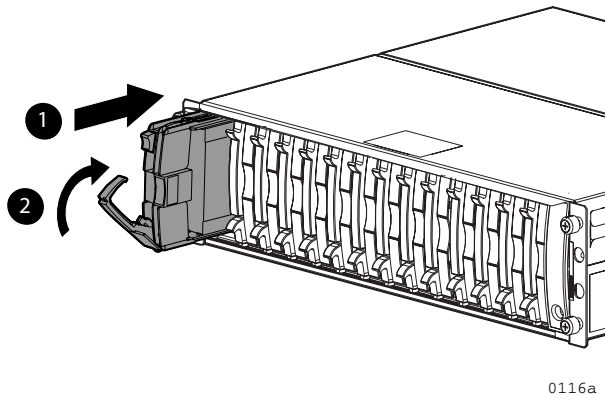

0116a

Figure 50 Installing a disk drive

Verifying proper operation

After replacing the disk drive, check the following to verify that the disk drive is operating normally:

 **NOTE:**

It may take up to 10 minutes for the component to display good status.

- Check the disk drive status indicators. See [Figure 48](#).
 - Activity indicator (1) should be on or flashing
 - Online indicator (2) should be on or flashing
 - Fault indicator (3) should be off
- Check the following using Command View EVA.
 - Navigate back to the component and check the operational state. It should be .
 - Record the **Model number** and the **Firmware version**. Check the firmware version against the supported disk firmware in the *HP StorageWorks Enterprise Virtual Array release notes*. The most current edition of the release notes can be downloaded from the following web site:

<http://www.hp.com/go/eva8000>

Click **Technical documentation**.

If the disk drive is using an unsupported version of firmware, download the correct firmware from the following web site and install it using the instructions included with the firmware file. Use the disk drive model number to locate the correct firmware file. Do not add the disk drive to a disk group if it using an unsupported firmware version.

<http://www.hp.com/support/evadiskfirmware>

Adding a disk to a disk group

After replacing the disk, it should be added to a disk group. The disk is typically added back into its original disk group.

1. In the Navigation pane, select **Storage system > Hardware > Rack > Disk enclosure > Bay**
2. In the Content pane, select the **Disk Drive** tab.
3. Click **Group** to initiate the process for adding the disk to a disk group.

 **NOTE:**

If the Device Addition Policy is set to automatic, the disk will automatically be added to a disk group. In this case the **Group** option will not be available.

Returning the failed component

Please follow the return instructions provided with the new component.

Replacing the disk enclosure power supply/blower

This section describes the procedure for replacing the power supply/blower assembly used in EVA 4000/6000/8000 products.

 **NOTE:**

Because this component is used in several products, the drawings may reflect a different enclosure than the one you have. The removal and replacement procedure is the same for each product.

Before you begin

Observe the following precautions when replacing the power supply/blower.

△ **CAUTION:**

You have only seven minutes to perform the replacement procedure! Both power supplies must be installed for the enclosure to cool properly. If a power supply fails, leave it in place in the enclosure until a new power supply is available to install. The enclosure could shut down due to overheating unless the power supply is replaced within seven minutes of removal of the failed/failing power supply.

If cabling is obstructing access to the power supply/blower, carefully move the cables out of the way to avoid loosening any connections.

Parts can be damaged by electrostatic discharge. Use proper anti-static protection. Refer to the documentation that shipped with your system for additional information.

Have a copy of the product User Guide available for reference. You can download a copy of the User Guide from the product support page on the HP web site.

Verifying component failure

△ **CAUTION:**

If Command View EVA does not present a status consistent with that of the power supply/blower status indicator, or if Command View or the System Event Analyzer indicates multiple hardware failures, contact HP support for assistance. The HP support web site is located at <http://www.hp.com/support>

The power supply and blower are separately replaceable components. Before replacing a power supply or blower, use the following methods to verify the component failure:

- Analyze any failure messages you may have received from system monitoring (System Event Analyzer).
- Check status using Command View EVA:
 1. In the Navigation pane, select **Storage system > Hardware > Rack > Disk enclosure**
 2. In the Content pane, select the **Power** tab or the **Cooling** tab then the appropriate component (1 or 2). The Operational state should be  Failed.
 3. To help identify the correct enclosure, click **Locate > Locate On** to flash the status indicators on the front of the disk enclosure.
- Check the power supply/blower status indicator. See [Figure 51](#). It should be off.

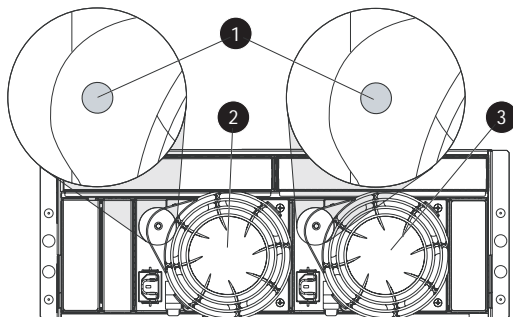

Figure 51 Power supply/blower status indicator

1. Status indicator
2. Power supply/blower 1
3. Power supply/blower 2

Removing a blower

It is not necessary to remove the power supply to replace a failed blower.

⚠ WARNING!

The blower motor does not stop immediately when the blower is removed. Keep your fingers away from the blower blades until the motor stops.

- While pushing in on the two wine-colored mounting tabs (1, [Figure 52](#)), pull the blower (2) away from the power supply.

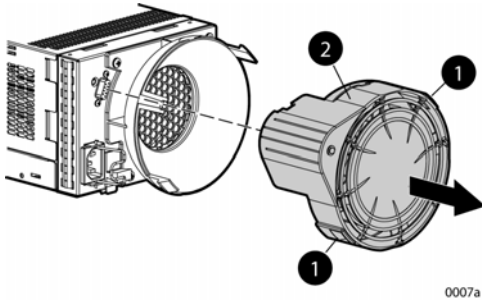

Figure 52 Removing a blower

Installing a blower

⚠ CAUTION:

Pressing on the center section of the blower can damage the blades or the housing. Only press on the outer edge of the blower when installing it.

1. Align the blower guide post (2, [Figure 53](#)) with the mounting hole next to the power supply connector (1).
2. Slide the blower onto the power supply (4) until the mounting tabs (3) snap into place.

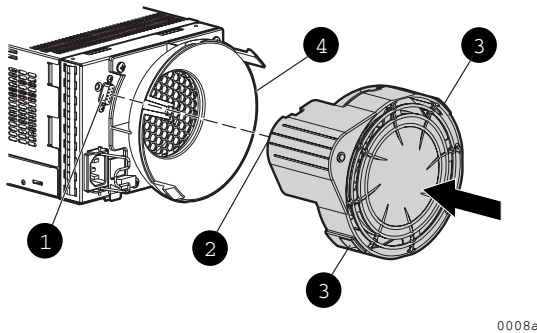

Figure 53 Installing a blower

Removing a power supply

⚠ CAUTION:

When a power supply is removed, the enclosure could shut down within seven minutes due to overheating unless the power supply is replaced.

1. Disengage the power cord lock (1, [Figure 54](#)) and disconnect the power cord from the power supply.

△ **CAUTION:**

When removing the left power supply, ensure the cord lock on the right power supply is engaged. This will avoid inadvertently disconnecting the right power supply. Also take care to avoid disrupting the cables on the I/O module to left of the power supply.

2. Lift up on the wine-colored mounting latch (2), then grasp the blower (3) and pull the power supply out of the enclosure.
3. Remove the blower from the defective power supply and install it on the replacement power supply.

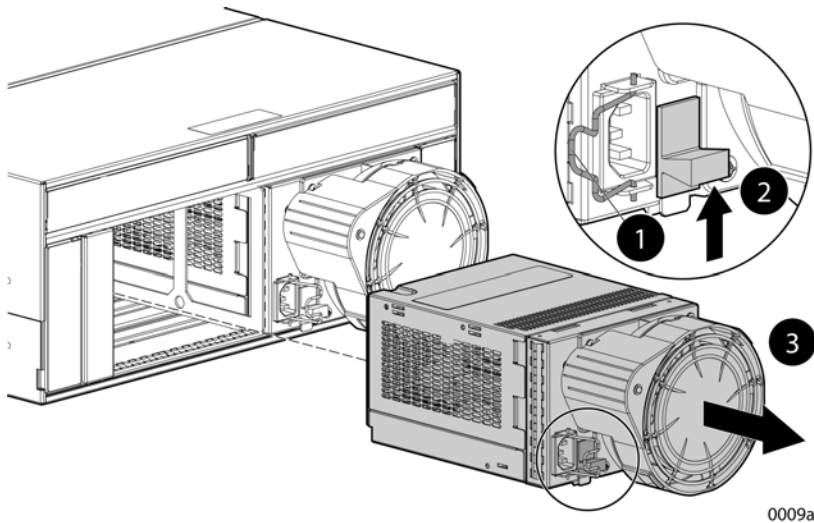

Figure 54 Removing a power supply

Installing a power supply

1. Lift up on the module latch (1, [Figure 55](#)) and slide the power supply into the enclosure until it is fully seated.
2. Connect the power cord to the power supply and engage the cord lock.

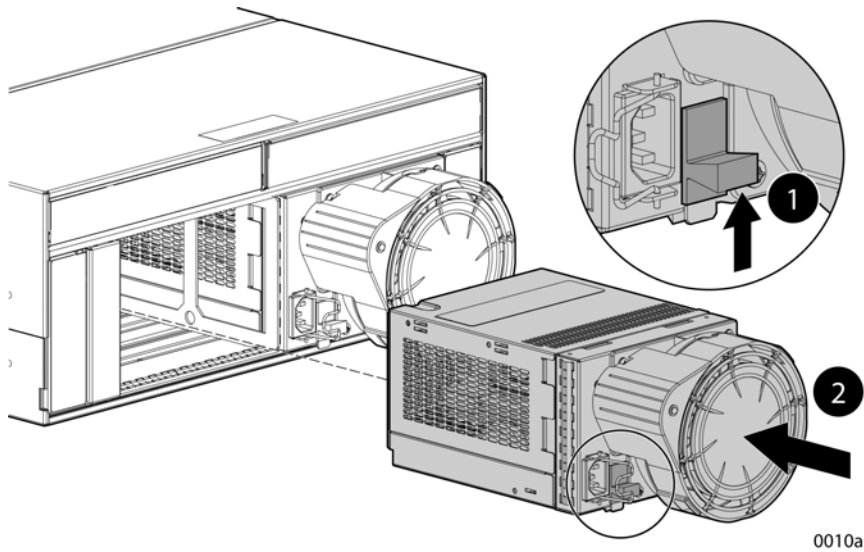



Figure 55 Installing a power supply

Verifying proper operation

After replacing the power supply or blower, check the following to verify that the component is operating properly:

NOTE:

It may take up to 10 minutes for the component to display good status.

- Make sure the blower begins operating immediately.
- The status indicator should be on.
- From Command View EVA
 - Navigate back to the component and check the status. It should be .
 - Turn off the locate function by clicking **Locate > Locate Off**

Returning the failed component

Please follow the return instructions provided with the new component.

A Regulatory notices and specifications

This appendix includes regulatory notices and product specifications for the HP StorageWorks Enterprise Virtual Array family.

The following topics are included:

- [Regulatory notices](#)
- [Storage system specifications](#)

Regulatory notices

Federal Communications Commission (FCC) notice

Part 15 of the Federal Communications Commission (FCC) Rules and Regulations has established Radio Frequency (RF) emission limits to provide an interference-free radio frequency spectrum. Many electronic devices, including computers, generate RF energy incidental to their intended function and are, therefore, covered by these rules. These rules place computers and related peripheral devices into two classes, A and B, depending upon their intended installation. Class A devices are those that may reasonably be expected to be installed in a business or commercial environment. Class B devices are those that may reasonably be expected to be installed in a residential environment (for example, personal computers). The FCC requires devices in both classes to bear a label indicating the interference potential of the device as well as additional operating instructions for the user.

The rating label on the device shows the classification (A or B) of the equipment. Class B devices have an FCC logo or FCC ID on the label. Class A devices do not have an FCC logo or FCC ID on the label. After the class of the device is determined, refer to the corresponding statement in the following sections.

FCC Class A certification

This equipment generates, uses, and may emit radio frequency energy. The equipment has been type tested and found to comply with the limits for a Class A digital device pursuant to Part 15 of the FCC rules, which are designed to provide reasonable protection against such radio frequency interference.

Operation of this equipment in a residential area may cause interference, in which case the user at the user's own expense will be required to take whatever measures may be required to correct the interference.

Any modifications to this device—unless approved by the manufacturer—can void the user's authority to operate this equipment under Part 15 of the FCC rules.

NOTE:

Additional information on the need to interconnect the device with shielded (data) cables or the need for special devices, such as ferrite beads on cables, is required if such means of interference suppression was used in the qualification test for the device. This information will vary from device to device and needs to be obtained from the HP EMC group.

Class A equipment

This equipment has been tested and found to comply with the limits for a Class A digital device, pursuant to Part 15 of the FCC Rules. These limits are designed to provide reasonable protection against harmful interference when the equipment is operated in a commercial environment. This equipment generates,

uses, and can radiate radio frequency energy and, if not installed and used in accordance with the instructions, may cause harmful interference to radio communications. Operation of this equipment in a residential area is likely to cause harmful interference, in which case the user will be required to correct the interference at personal expense.

Class B equipment

This equipment has been tested and found to comply with the limits for a Class B digital device, pursuant to Part 15 of the FCC Rules. These limits are designed to provide reasonable protection against harmful interference in a residential installation. This equipment generates, uses, and can radiate radio frequency energy and, if not installed and used in accordance with the instructions, may cause harmful interference to radio communications. However, there is no guarantee that interference will not occur in a particular installation. If this equipment does cause harmful interference to radio or television reception, which can be determined by turning the equipment off and on, the user is encouraged to try to correct the interference by one or more of the following measures:

- Reorient or relocate the receiving antenna.
- Increase the separation between the equipment and receiver.
- Connect the equipment into an outlet on a circuit that is different from that to which the receiver is connected.
- Consult the dealer or an experienced radio or television technician for help.

Declaration of conformity for products marked with the FCC logo, United States only

This device complies with Part 15 of the FCC Rules. Operation is subject to the following two conditions: (1) this device may not cause harmful interference, and (2) this device must accept any interference received, including interference that may cause undesired operation.

For questions regarding your product, refer to <http://thenew.hp.com>.

For questions regarding this FCC declaration, contact:

- Hewlett-Packard Company Product Regulations Manager 3000 Hanover St. Palo Alto, CA 94304
- Or call 1-650-857-1501

To identify this product, refer to the part, series, or model number found on the product.

Modifications

The FCC requires the user to be notified that any changes or modifications made to this device that are not expressly approved by Hewlett-Packard Company may void the user's authority to operate the equipment.

Cables

Connections to this device must be made with shielded cables with metallic RFI/EMI connector hoods in order to maintain compliance with FCC Rules and Regulations.

Laser device

All Hewlett-Packard systems equipped with a laser device comply with safety standards, including International Electrotechnical Commission (IEC) 825. With specific regard to the laser, the equipment complies with laser product performance standards set by government agencies as a Class 1 laser product. The product does not emit hazardous light; the beam is totally enclosed during all modes of customer operation and maintenance.

Laser safety warnings

Heed the following warning:

⚠ **WARNING!**

WARNING: To reduce the risk of exposure to hazardous radiation:

- Do not try to open the laser device enclosure. There are no user-serviceable components inside.
 - Do not operate controls, make adjustments, or perform procedures to the laser device other than those specified herein.
 - Allow only HP authorized service technicians to repair the laser device.
-

Compliance with CDRH regulations

The Center for Devices and Radiological Health (CDRH) of the U.S. Food and Drug Administration implemented regulations for laser products on August 2, 1976. These regulations apply to laser products manufactured from August 1, 1976. Compliance is mandatory for products marketed in the United States.

Certification and classification information

This product contains a laser internal to the Optical Link Module (OLM) for connection to the Fibre communications port.

In the USA, the OLM is certified as a Class 1 laser product conforming to the requirements contained in the Department of Health and Human Services (DHHS) regulation 21 CFR, Subchapter J. The certification is indicated by a label on the plastic OLM housing.

Outside the USA, the OLM is certified as a Class 1 laser product conforming to the requirements contained in IEC 825-1:1993 and EN 60825-1:1994, including Amendment 11:1996.

The OLM includes the following certifications:

- UL Recognized Component (USA)
- CSA Certified Component (Canada)
- TUV Certified Component (European Union)
- CB Certificate (Worldwide)

Canadien notice (avis Canadien)

Class A equipment

This Class A digital apparatus meets all requirements of the Canadian Interference-Causing Equipment Regulations.

Cet appareil numérique de la classe A respecte toutes les exigences du Règlement sur le matériel brouilleur du Canada.

Class B equipment

This Class B digital apparatus meets all requirements of the Canadian Interference-Causing Equipment Regulations.

Cet appareil numérique de la classe B respecte toutes les exigences du Règlement sur le matériel brouilleur du Canada.

European union notice

Products with the CE Marking comply with both the EMC Directive (89/336/EEC) and the Low Voltage Directive (73/23/EEC) issued by the Commission of the European Community.

Compliance with these directives implies conformity to the following European Norms (the equivalent international standards are in parenthesis):

- EN55022 (CISPR 22) - Electromagnetic Interference
- EN55024 (IEC61000-4-2, 3, 4, 5, 6, 8, 11) - Electromagnetic Immunity
- EN61000-3-2 (IEC61000-3-2) - Power Line Harmonics
- EN61000-3-3 (IEC61000-3-3) - Power Line Flicker
- EN60950 (IEC950) - Product Safety

Notice for France

DECLARATION D'INSTALLATION ET DE MISE EN EXPLOITATION d'un matériel de traitement de l'information (ATI), classé A en fonction des niveaux de perturbations radioélectriques émis, définis dans la norme européenne EN 55022 concernant la Compatibilité Electromagnétique.

WEEE Recycling Notices

English notice

Disposal of waste equipment by users in private household in the European Union



■ This symbol on the product or on its packaging indicates that this product must not be disposed of with your other household waste. Instead, it is your responsibility to dispose of your waste equipment by handing it over to a designated collection point for recycling of waste electrical and electronic equipment. The separate collection and recycling of your waste equipment at the time of disposal will help to conserve natural resources and ensure that it is recycled in a manner that protects human health and the environment. For more information about where you can drop off your waste equipment for recycling, please contact your local city office, your household waste disposal service, or the shop where you purchased the product.

Dutch notice

Verwijdering van afgedankte apparatuur door privé-gebruikers in de Europese Unie



■ Dit symbool op het product of de verpakking geeft aan dat dit product niet mag worden gedeponneerd bij het normale huishoudelijke afval. U bent zelf verantwoordelijk voor het inleveren van uw afgedankte apparatuur bij een inzamelingspunt voor het recyclen van oude elektrische en elektronische apparatuur. Door uw oude apparatuur apart aan te bieden en te recyclen, kunnen natuurlijke bronnen worden behouden en kan het materiaal worden hergebruikt op een manier waarmee de volksgezondheid en het milieu worden beschermd. Neem contact op met uw gemeente, het afvalinzamelingsbedrijf of de winkel waar u het product hebt gekocht voor meer informatie over inzamelingspunten waar u oude apparatuur kunt aanbieden voor recycling.

Czechoslovakian notice

Likvidace zařízení soukromými domácími uživateli v Evropské unii



■ Tento symbol na produktu nebo balení označuje výrobek, který nesmí být vyhozen spolu s ostatním domácím odpadem. Povinností uživatele je předat takto označený odpad na předem určené sběrné místo pro recyklaci elektrických a elektronických zařízení. Okamžité třídění a recyklace odpadu pomůže uchovat přírodní prostředí a zajistí takový způsob recyklace, který ochrání zdraví a životní prostředí člověka. Další informace o možnostech odevzdání odpadu k recyklaci získáte na příslušném obecním nebo městském úřadě, od firmy zabývající se sběrem a svozem odpadu nebo v obchodě, kde jste produkt zakoupili.

Estonian notice

Seadmete jäätmete kõrvaldamine eramajapidamistes Euroopa Liidus



■ See tootel või selle pakendil olev sümbol näitab, et kõnealust toodet ei tohi koos teiste majapidamisjätmetega kõrvaldada. Teie kohus on oma seadmete jäätmed kõrvaldada, viies need elektri- ja elektroonikaseadmete jäätmete ringlussevõtmiseks selleks ettenähtud kogumispunkti. Seadmete jäätmete eraldi kogumine ja ringlussevõtmine kõrvaldamise ajal aitab kaitsta loodusvarasid ning tagada, et ringlussevõtmine toimub viisil, mis kaitseb inimeste tervist ning keskkonda. Lisateabe saamiseks selle kohta, kuhu oma seadmete jäätmed ringlussevõtmiseks viia, võtke palun ühendust oma kohaliku linnakantselei, majapidamisjätmete kõrvaldamise teenistuse või kauplusega, kust Te toote ostsite.

Finnish notice

Laitteiden hävittäminen kotitalouksissa Euroopan unionin alueella



■ Jos tuotteessa tai sen pakkauksessa on tämä merkki, tuotetta ei saa hävittää kotitalousjätteiden mukana. Tällöin hävitettävä laite on toimitettava sähkölaitteiden ja elektronisten laitteiden kierrätyspisteeseen. Hävitettävien laitteiden erillinen käsittely ja kierrätys auttavat säästämään luonnonvaroja ja varmistamaan, että laite kierrätetään tavalla, joka estää terveyshaitat ja suojelee luontoa. Lisätietoja paikoista, joihin hävitettävät laitteet voi toimittaa kierrätettäväksi, saa ottamalla yhteyttä jätteenhoitoon tai liikkeeseen, josta tuote on ostettu.

French notice

Élimination des appareils mis au rebut par les ménages dans l'Union européenne



■ Le symbole apposé sur ce produit ou sur son emballage indique que ce produit ne doit pas être jeté avec les déchets ménagers ordinaires. Il est de votre responsabilité de mettre au rebut vos appareils en les déposant dans les centres de collecte publique désignés pour le recyclage des équipements électriques et électroniques. La collecte et le recyclage de vos appareils mis au rebut indépendamment du reste des déchets contribue à la préservation des ressources naturelles et garantit que ces appareils seront recyclés dans le respect de la santé humaine et de l'environnement. Pour obtenir plus d'informations sur les centres de collecte et de recyclage des appareils mis au rebut, veuillez contacter les autorités locales de votre région, les services de collecte des ordures ménagères ou le magasin dans lequel vous avez acheté ce produit.

German notice

Entsorgung von Altgeräten aus privaten Haushalten in der EU



■ Das Symbol auf dem Produkt oder seiner Verpackung weist darauf hin, dass das Produkt nicht über den normalen Hausmüll entsorgt werden darf. Benutzer sind verpflichtet, die Altgeräte an einer Rücknahmestelle für Elektro- und Elektronik-Altgeräte abzugeben. Die getrennte Sammlung und ordnungsgemäße Entsorgung Ihrer Altgeräte trägt zur Erhaltung der natürlichen Ressourcen bei und garantiert eine Wiederverwertung, die die Gesundheit des Menschen und die Umwelt schützt. Informationen dazu, wo Sie Rücknahmestellen für Ihre Altgeräte finden, erhalten Sie bei Ihrer Stadtverwaltung, den örtlichen Müllentsorgungsbetrieben oder im Geschäft, in dem Sie das Gerät erworben haben.

Greek notice

Απορριψη άχρηστου εξοπλισμού από χρήστες σε ιδιωτικά νοικοκυριά στην Ευρωπαϊκή Ένωση



■ Το σύμβολο αυτό στο προϊόν ή τη συσκευασία του υποδεικνύει ότι το συγκεκριμένο προϊόν δεν πρέπει να διατίθεται μαζί με τα άλλα οικιακά σας απορρίμματα. Αντίθετα, είναι δική σας ευθύνη να απορρίψετε τον άχρηστο εξοπλισμό σας παραδίδοντάς τον σε καθορισμένο σημείο συλλογής για την ανακύκλωση άχρηστου ηλεκτρικού και ηλεκτρονικού εξοπλισμού. Η ξεχωριστή συλλογή και ανακύκλωση του άχρηστου εξοπλισμού σας κατά την απόρριψη θα συμβάλει στη διατήρηση των φυσικών πόρων και θα διασφαλίσει ότι η ανακύκλωση γίνεται με τρόπο που προστατεύει την ανθρώπινη υγεία και το περιβάλλον. Για περισσότερες πληροφορίες σχετικά με το πού μπορείτε να παραδώσετε τον άχρηστο εξοπλισμό σας για ανακύκλωση, επικοινωνήστε με το αρμόδιο τοπικό γραφείο, την τοπική υπηρεσία διάθεσης οικιακών απορριμμάτων ή το κατάστημα όπου αγοράσατε το προϊόν.

Hungarian notice

Készülékek magánháztartásban történő selejtezése az Európai Unió területén



■ A készüléken, illetve a készülék csomagolásán látható azonos szimbólum annak jelzésére szolgál, hogy a készülék a selejtezés során az egyéb háztartási hulladéktól eltérő módon kezelendő. A vásárló a hulladékká vált készüléket köteles a kijelölt gyűjtőhelyre szállítani az elektromos és elektronikai készülékek újrahasznosítása céljából. A hulladékká vált készülékek selejtezési begyűjtése és újrahasznosítása hozzájárul a természeti erőforrások megőrzéséhez, valamint biztosítja a selejtezett termékek környezetre és emberi egészségre nézve biztonságos feldolgozását. A begyűjtés pontos helyéről bővebb tájékoztatást a lakhelye szerint illetékes önkormányzattól, az illetékes személtakarító vállalatától, illetve a terméket elárúsító helyen kaphat.

Italian notice

Smaltimento delle apparecchiature da parte di privati nel territorio dell'Unione Europea



■ Questo simbolo presente sul prodotto o sulla sua confezione indica che il prodotto non può essere smaltito insieme ai rifiuti domestici. È responsabilità dell'utente smaltire le apparecchiature consegnandole presso un punto di raccolta designato al riciclo e allo smaltimento di apparecchiature elettriche ed elettroniche. La raccolta differenziata e il corretto riciclo delle apparecchiature da smaltire permette di proteggere la salute degli individui e l'ecosistema. Per ulteriori informazioni relative ai punti di raccolta delle apparecchiature, contattare l'ente locale per lo smaltimento dei rifiuti, oppure il negozio presso il quale è stato acquistato il prodotto.

Latvian notice

Nolietotu iekārtu iznīcināšanas noteikumi lietotājiem Eiropas Savienības privātajās mājāsaimniecībās



■ Šāds simbols uz izstrādājuma vai uz tā iesaiņojuma norāda, ka šo izstrādājumu nedrīkst izmest kopā ar citiem sadzīves atkritumiem. Jūs atbildat par to, lai nolietotās iekārtas tiktu nodotas speciāli iekārtotos punktos, kas paredzēti izmantoto elektrisko un elektronisko iekārtu savākšanai otrreizējai pārstrādei. Atsevišķa nolietoto iekārtu savākšana un otrreizējā pārstrāde palīdzēs saglabāt dabas resursus un garantēs, ka šīs iekārtas tiks otrreizēji pārstrādātas tādā veidā, lai pasargātu vidi un cilvēku veselību. Lai uzzinātu, kur nolietotās iekārtas var izmest otrreizējai pārstrādei, jāvērsas savas dzīves vietas pašvaldībā, sadzīves atkritumu savākšanas dienestā vai veikalā, kurā izstrādājums tika nopirkts.

Lithuanian notice

Vartotojų iš privačių namų ūkių įrangos atliekų šalinimas Europos Sąjungoje



Šis simbolis ant gaminio arba jo pakuotės rodo, kad šio gaminio šalinti kartu su kitomis namų ūkio atliekomis negalima. Šalintinas įrangos atliekas privalote pristatyti į specialią surinkimo vietą elektros ir elektroninės įrangos atliekoms perdirbti. Atskirai surenkamos ir perdirbamos šalintinos įrangos atliekos padės saugoti gamtinius išteklius ir užtikrinti, kad jos bus perdirbtos tokiu būdu, kuris nekenkia žmonių sveikatai ir aplinkai. Jeigu norite sužinoti daugiau apie tai, kur galima pristatyti perdirbtinas įrangos atliekas, kreipkitės į savo seniūniją, namų ūkio atliekų šalinimo tarnybą arba parduotuvę, kurioje įsigijote gaminį.

Polish notice

Pozbywanie się zużytego sprzętu przez użytkowników w prywatnych gospodarstwach domowych w Unii Europejskiej



Ten symbol na produkcie lub jego opakowaniu oznacza, że produktu nie wolno wyrzucać do zwykłych pojemników na śmieci. Obowiązkiem użytkownika jest przekazanie zużytego sprzętu do wyznaczonego punktu zbiórki w celu recyklingu odpadów powstających ze sprzętu elektrycznego i elektronicznego. Osobna zbiórka oraz recykling zużytego sprzętu pomogą w ochronie zasobów naturalnych i zapewnią ponowne wprowadzenie go do obiegu w sposób chroniący zdrowie człowieka i środowisko. Aby uzyskać więcej informacji o tym, gdzie można przekazać zużyty sprzęt do recyklingu, należy się skontaktować z urzędem miasta, zakładem gospodarki odpadami lub sklepem, w którym zakupiono produkt.

Portuguese notice

Descarte de Lixo Elétrico na Comunidade Européia



Este símbolo encontrado no produto ou na embalagem indica que o produto não deve ser descartado no lixo doméstico comum. É responsabilidade do cliente descartar o material usado (lixo elétrico), encaminhando-o para um ponto de coleta para reciclagem. A coleta e a reciclagem seletivas desse tipo de lixo ajudarão a conservar as reservas naturais; sendo assim, a reciclagem será feita de uma forma segura, protegendo o ambiente e a saúde das pessoas. Para obter mais informações sobre locais que reciclam esse tipo de material, entre em contato com o escritório da HP em sua cidade, com o serviço de coleta de lixo ou com a loja em que o produto foi adquirido.

Slovakian notice

Likvidácia vyradených zariadení v domácnostiach v Európskej únii



Symbol na výrobku alebo jeho balení označuje, že daný výrobok sa nesmie likvidovať s domovým odpadom. Povinnosťou spotrebiteľa je odovzdať vyradené zariadenie v zbernom mieste, ktoré je určené na recykláciu vyradených elektrických a elektronických zariadení. Separovaný zber a recyklácia vyradených zariadení prispieva k ochrane prírodných zdrojov a zabezpečuje, že recyklácia sa vykonáva spôsobom chrániacim ľudské zdravie a životné prostredie. Informácie o zberných miestach na recykláciu vyradených zariadení vám poskytne miestne zastupiteľstvo, spoločnosť zabezpečujúca odvoz domového odpadu alebo obchod, v ktorom ste si výrobok zakúpili.

Slovenian notice

Odstranjevanje odslužene opreme uporabnikov v zasebnih gospodinjstvih v Evropski uniji



■ Ta znak na izdelku ali njegovi embalaži pomeni, da izdelka ne smete odvreči med gospodinjske odpadke. Nasprotno, odsluženo opremo morate predati na zbirališče, pooblaščen za recikliranje odslužene električne in elektronske opreme. Ločeno zbiranje in recikliranje odslužene opreme prispeva k ohranjanju naravnih virov in zagotavlja recikliranje te opreme na zdravju in okolju neškodljiv način. Za podrobnejše informacije o tem, kam lahko odpeljete odsluženo opremo na recikliranje, se obrnite na pristojni organ, komunalno službo ali trgovino, kjer ste izdelek kupili.

Spanish notice

Eliminación de residuos de equipos eléctricos y electrónicos por parte de usuarios particulares en la Unión Europea



■ Este símbolo en el producto o en su envase indica que no debe eliminarse junto con los desperdicios generales de la casa. Es responsabilidad del usuario eliminar los residuos de este tipo depositándolos en un "punto limpio" para el reciclado de residuos eléctricos y electrónicos. La recogida y el reciclado selectivos de los residuos de aparatos eléctricos en el momento de su eliminación contribuirá a conservar los recursos naturales y a garantizar el reciclado de estos residuos de forma que se proteja el medio ambiente y la salud. Para obtener más información sobre los puntos de recogida de residuos eléctricos y electrónicos para reciclado, póngase en contacto con su ayuntamiento, con el servicio de eliminación de residuos domésticos o con el establecimiento en el que adquirió el producto.

Swedish notice

Bortskaffande av avfallsprodukter från användare i privathushåll inom Europeiska Unionen



■ Om den här symbolen visas på produkten eller förpackningen betyder det att produkten inte får slängas på samma ställe som hushållssopor. I stället är det ditt ansvar att bortskaffa avfallet genom att överlämna det till ett uppsamlingsställe avsett för återvinning av avfall från elektriska och elektroniska produkter. Separat insamling och återvinning av avfallet hjälper till att spara på våra naturresurser och gör att avfallet återvinns på ett sätt som skyddar människors hälsa och miljön. Kontakta ditt lokala kommunkontor, din närmsta återvinningsstation för hushållsavfall eller affären där du köpte produkten för att få mer information om var du kan lämna ditt avfall för återvinning.

Germany noise declaration

Schalldruckpegel $L_p = 70$ dB(A)

Am Arbeitsplatz (operator position)

Normaler Betrieb (normal operation)

Nach ISO 7779:1999 (Typprüfung)

Japanese notice

ご使用になっている装置にVCCIマークが付いていましたら、次の説明文をお読み下さい。

この装置は、情報処理装置等電波障害自主規制協議会（VCCI）の基準に基づくクラスB情報技術装置です。この装置は、家庭環境で使用することを目的としていますが、この装置がラジオやテレビジョン受信機に近接して使用されると、受信障害を引き起こすことがあります。
取扱説明書に従って正しい取り扱いをして下さい。

VCCIマークが付いていない場合には、次の点にご注意下さい。

この装置は、情報処理装置等電波障害自主規制協議会（VCCI）の基準に基づくクラスA情報技術装置です。この装置を家庭環境で使用すると電波妨害を引き起こすことがあります。この場合には使用者が適切な対策を講ずるよう要求されることがあります。

Harmonics conformance (Japan)

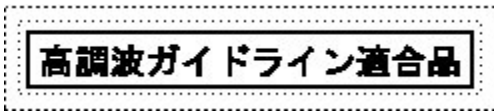

Taiwanese notice

警告使用者:

這是甲類的資訊產品，在居住的環境中使用時，可能會造成射頻干擾，在這種情況下，使用者會被要求採取某些適當的對策。

Japanese power cord notice

製品には、同梱された電源コードをお使い下さい。
同梱された電源コードは、他の製品では使用出来ません。

Country-specific certifications

HP tests electronic products for compliance with country-specific regulatory requirements, as an individual item or as part of an assembly. The product label (see [Figure 56](#)) specifies the regulations with which the product complies.

NOTE:

Components without an individual product certification label are qualified as part of the next higher assembly (for example, enclosure, rack, or tower).



CXO8157A

Figure 56 Typical enclosure certification label



NOTE:

The certification symbols on the label depend upon the certification level. For example, the FCC Class A certification symbol is not the same as the FCC Class B certification symbol.

Storage system specifications

This appendix defines the physical, environmental, and power specifications of the EVA 4000/6000/8000 storage systems.

Physical specifications

This section describes the physical specifications of the drive enclosure and elements.

Table 30 defines the dimensions and weights of the storage system components.

Table 30 Enterprise Virtual Array 4000/6000/8000 Product Dimensions, Weight and Clearance

Physical Dimensions	Height in/cm	Width in/cm	Depth in/cm	Max Weight lb/kg	Req. Front Clearance in/cm	Req. Rear Clearance in/cm
EVA4000/8000 2C2D (42U rack)	78.75 (200.03)	23.7 (60.3)	40.2 (102.2)	537 (244.1)	30 (76.2)	30 (76.2)
EVA6000/8000 2C6D (42U rack)	78.75 (200.03)	23.7 (60.3)	40.2 (102.2)	854 (308.2)	30 (76.2)	30 (76.2)
EVA8000 2C12D (42U rack)	78.75 (200.03)	23.7 (60.3)	40.2 (102.2)	1290 (586.4)	30 (76.2)	30 (76.2)
EVA4000/6000/8000 Controller Assembly	7.0/17.78	17.6/44.70	27.5/69.85	120/54.55	N/A	N/A
M5314B Drive Enclosure	5.25/13.34	19.0/42.26	20/50.8	71/32.21	N/A	N/A

Environmental specifications

To ensure optimum product operation, you must maintain the operational environmental specifications listed in Table 31. The ambient temperature (the enclosure air intake or room temperature) is especially critical.

Table 31 Environmental specifications

Operating Temperature	50° to 95° F (10° to 35° C) - Reduce rating by 1° F for each 1000 ft altitude (1.8° C/1,000 m)
Shipping Temperature	-40° to 150° F (-40° to 66° C)
Humidity	10% to 90% non-condensing
Shipping Humidity	5% to 90% non-condensing
Altitude	Up to 8,000 ft (2,400 m)
Air Quality	Not to exceed 500,000 particles per cubic foot of air at a size of 0.5 micron or larger

Power specifications

The input voltage is a function of the country-specific input voltage to Enterprise storage system rack power distribution units (PDUs). [Enterprise storage system AC input line voltages](#) defines the AC input power available to the drive enclosure power supplies.

△ **CAUTION:**

The AC power distribution within a rack ensures a balanced to each PDA and reduces the possibility of an overload condition. Changing the cabling to or from a PDM could cause an overload condition.

Table 32 Enterprise storage system AC input line voltages

Specification	Minimal	Nominal	Maximum
	60 Hz service		
AC Line Voltage	57 Hz	60 Hz	63 Hz
AC Line Voltage—Japan	180 VAC	202 VAC	220 VAC
AC Line Voltage—North America	180 VAC	208 VAC	220 VAC
AC Line Voltage—Europe	208 VAC	240 VAC	254 VAC
	50 Hz service		
AC Line Frequency	47 Hz	50 Hz	53 Hz
AC Line Voltage—Japan	180 VAC	202 VAC	220 VAC
AC Line Voltage—North America	190 VAC	220 VAC	235 VAC
AC Line Voltage—North America	200 VAC	230 VAC	244 VAC
AC Line Voltage—Europe	208 VAC	240 VAC	254 VAC

Table 33 Power Data (North America/Europe/Japan) maximum configuration

AC plug type (quantity 2)	North America – 3 wire NEMA No. L6-30R, 30 amp (208 to 240V 60Hz 30A) Europe – 3 wire, 2 pole IEC 309, 30 amp, (220 to 240V 50Hz 32A)
Number of phases	Single
Rated current	17A @ 200V-240V AC, 60Hz total, 4.25 A per power cord
Nominal Line Voltage	North America – 208 or 230V Europe – 230V Japan – 206V
Range Line Voltage	187 to 256V
Line Frequency	North America 60Hz, Europe 50Hz, Japan 50 or 60 Hz

Table 34 EVA4000 power specifications – 208 Volts

Specification		2C1D	2C2D	2C3D	2C4D
Typical ¹	Total System Wattage	507	883	1260	1637
	Total System BTU/hour	1729	3014	4300	5585
	Input Current (A) - Typical per system	2.5	4.4	6.3	8.2
	In Rush Current (A)	98	132	170	220
Failover Mode	Input Current (A) - Maximum per system	2.0	3.3	4.6	5.9

¹ Typical is described as a system in normal steady state operation. (I.e., both PDUs operating normally, the array reading/writing to disk drives in a production environment)

This data represents fully populated drive enclosures with 10K rpm disk drives. Other drive types may vary slightly.

Table 35 EVA4000 power specifications – 230 Volts

Specification		2C1D	2C2D	2C3D	2C4D
Typical ¹	Total System Wattage	507	883	1260	1637
	Total System BTU/hour	1729	3014	4300	5585
	Input Current (A) - Typical per system	2.3	4.0	5.7	7.4
	In Rush Current (A)	104	147	190	244
Failover Mode	Input Current (A) - Maximum per system	1.9	3.1	4.3	5.4

¹ Typical is described as a system in normal steady state operation. (I.e., both PDUs operating normally, the array reading/writing to disk drives in a production environment)

This data represents fully populated drive enclosures with 10K rpm disk drives. Other drive types may vary slightly.

Table 36 EVA6000 power specifications – 208 Volts

Specification		2C4D	2C5D	2C6D	2C7D	2C8D
Typical ¹	Total System Wattage	1707	2084	2460	2837	3214
	Total System BTU/hour	5824	7109	8395	9680	10965
	Input Current (A) - Typical per system	8.5	10.4	12.3	14.1	16.0
	In Rush Current (A)	220	250	280	321	363
Failover Mode	Input Current (A) - Maximum per system	5.9	7.1	8.3	9.5	10.8

¹ Typical is described as a system in normal steady state operation. (I.e., both PDUs operating normally, the array reading/writing to disk drives in a production environment)

This data represents fully populated drive enclosures with 10K rpm disk drives. Other drive types may vary slightly.

Table 37 EVA6000 power specifications – 230 Volts

Specification		2C4D	2C5D	2C6D	2C7D	2C8D
Typical ¹	Total System Wattage	1707	2084	2460	2837	3214
	Total System BTU/hour	5824	7109	8395	9680	10965
	Input Current (A) - Typical per system	7.7	9.4	11.1	12.8	14.5
	In Rush Current (A)	244	272	311	357	403
Failover Mode	Input Current (A) - Maximum per system	5.4	6.5	7.5	8.5	9.5

¹ Typical is described as a system in normal steady state operation. (I.e., both PDUs operating normally, the array reading/writing to disk drives in a production environment)

This data represents fully populated drive enclosures with 10K rpm disk drives. Other drive types may vary slightly.

Table 38 EVA8000 power specifications – 208 Volts

Specification		2C2D	2C6D	2C8D	2C10D	2C12D
Typical ¹	Total System Wattage	1023	2530	3284	4037	4920
	Total System BTU/hour	3492	8633	11204	13775	16789
	Input Current (A) - Typical per system	5.1	12.6	16.4	20.1	24.5
	In Rush Current (A)	132	280	363	451	528
Failover Mode	Input Current (A) - Maximum per system	3.3	8.3	10.8	13.1	15.5

¹ Typical is described as a system in normal steady state operation. (I.e., both PDUs operating normally, the array reading/writing to disk drives in a production environment)

This data represents fully populated drive enclosures with 10K rpm disk drives. Other drive types may vary slightly.

Table 39 EVA8000 power specifications – 230 Volts

Specification		2C2D	2C6D	2C8D	2C10D	2C12D
Typical ¹	Total System Wattage	1023	2530	3284	4037	4920
	Total System BTU/hour	3492	8633	11204	13775	16789
	Input Current (A) - Typical per system	4.6	11.4	14.8	18.2	21.6
	In Rush Current (A)	147	311	403	500	586
Failover Mode	Input Current (A) - Maximum per system	3.1	7.5	9.5	12.1	14.0

¹ Typical is described as a system in normal steady state operation. (I.e., both PDUs operating normally, the array reading/writing to disk drives in a production environment)

This data represents fully populated drive enclosures with 10K rpm disk drives. Other drive types may vary slightly.

B EMU-generated condition reports

This section provides a description of the EMU generated condition reports that contain the following information:

- Element type (*et*), a hexadecimal number in the range *01* through *FF*.
- Element number (*en*), a decimal number in the range *00* through *99* that defines a specific problem.
- Error code (*ec*), a decimal number in the range *00* through *99*.
- The recommended corrective action.

 **NOTE:**

The conventions used to differentiate between the elements of the condition report are:

- Element type—period after each character
- Element number—period after the second character
- Error code—no periods

The EMU can send error messages to the controller for transmission to HP Command View EVA. The messages displayed are specific to HP Command View EVA and are not within the scope of this publication.

The I/O modules have the built-in intelligence to:

- Observe fibre channel events
- Bypass drive ports based on events
- Perform drive port testing and monitoring to prevent poor-performing drives from participating in the loop
- Communicate fibre channel events to the controllers

This appendix explains the condition report format, correcting problems, and how to identify element types. The error codes are arranged in element type sequence (that is, *0.1.*, *0.2.*, *0.3.*, *etc.*).

Condition report format

When the EMU alphanumeric display is *Er*, three additional displays identify the possible cause of the problem: the element type, the specific element, and the error code, which defines the possible cause of the problem.

- The first-level display identifies the type of element affected with two alphanumeric characters separated by periods such as *0.1.*, *0.2.*, *1.3.*, *FF.*, and so forth. A disk drive problem would display an element type number of *0.1*.
- The second-level display identifies the element affected with a two-digit, decimal number followed by a period. For example, when a **bay** 6 drive error occurs, the element number display is *06.*; a display of *14.* indicates a **bay** 14 problem.
- The third-level display identifies a specific problem, the error code with a two-digit, decimal number. For example, should the problem be either the installation of an incorrectly configured drive or one that cannot operate at the loop link rate, the display is *01*.

Correcting errors

Correcting an error may require you to perform a specific set of actions. In some cases, the only available corrective action is to replace the element.

Table 40 lists the element type codes assigned to the drive enclosure elements.

Table 40 Assigned element type codes

Code	Element
0.1.	Disk Drives
0.2.	Power Supplies
0.3.	Blowers
0.4.	Temperature Sensors
0.6	Audible Alarm ¹
0.7.	EMU
0.C.	Controller OCP LCD ¹
0.F.	Transceivers
1.0.	Language ¹
1.1.	Communication Port ¹
1.2.	Voltage Sensors
1.	Current Sensors
8.0	Drive Enclosure ¹
8.2.	Drive Enclosure Backplane
8.7.	I/O Modules

¹Does not generate a condition report. However, for any error, you should record the error code. Then, implement the recommended corrective action.

Drive conditions

The format of a disk drive condition report is *0.1.en.ec*, where:

- *0.1.* is the disk drive element type number
- *en.* is the two-character disk drive element
- *ec* is the error code

A direct correlation exists between the disk drive element number and the bay number. However, no direct correlation exists between the disk drive bay number and the device Fibre Channel drive enclosure physical address. The Fibre Channel drive enclosure physical address is assigned by negotiation during system initialization.

The following sections define the disk drive error codes.

0.1.en.01 CRITICAL condition—Drive configuration or drive link rate

As each drive spins up and comes on-line, the EMU determines if the drive is Fibre Channel compatible and can operate at the link rate (1 Gbps or 2 Gbps) established by the I/O module. If either of these conditions are not met, the EMU issues the condition report *0.1.en.01*.

The corrective actions for these conditions are:

- When the drive is not Fibre Channel-compatible you must install a Fibre Channel compatible drive or a drive blank.

- When the drive is Fibre Channel-compatible, the EMU compares the drive link rate with the I/O module link rate, the loop link rate.

If the EMU cannot determine the drive link rate, the EMU activates the drive bypass function for one minute. During this time the EMU continually checks the drive to determine the link rate.

- If the EMU determines the drive cannot operate at the Fibre Channel link rate set by the I/O module, the drive bypass function ends and the drive is placed on the loop. This does not generate a condition report.
- The EMU issues the condition report *0.1.en.01* when the drive link rate is incompatible with Fibre Channel link rate.
- When the EMU cannot determine the drive link rate during the one-minute drive bypass time, the EMU places the drive on the loop. This process allows the drive to negotiate for an address.
 - If negotiation indicates the link rates are compatible, the EMU rechecks the drive link rate to verify compatibility.
 - If negotiation indicates the link rates are incompatible, an error condition exists and drive loop data transfers stop.

This condition report remains active until the problem is corrected. The problem affects disk drive en. Therefore, correction to prevent the possible failure of other elements is not required.

Complete the following procedure to correct this problem:

1. Record all six characters of the condition report.
2. Replace the defective drive with:
 - A Fibre Channel-compatible drive.
 - A Fibre Channel drive capable of operating at a link rate supported by I/O modules and transceivers.
3. Observe the EMU to ensure the error is corrected.
4. If unable to correct the problem, contact your authorized service representative.

0.1.en.02 INFORMATION condition—Drive missing

The drive is improperly installed or missing. Either option could affect the enclosure air flow and cause an overtemperature condition for another element.

- This error remains active for one minute, or until the problem is corrected, whichever *occurs first*.
- Immediate correction is not required. However, correction cannot be delayed indefinitely.

Complete the following procedure to correct this problem.

1. Record all six characters of the condition report.
2. Remove and install the drive to ensure that it is properly installed.
3. Observe the EMU to ensure the error is corrected.
4. If removing and installing the drive did not correct the problem, install a replacement drive or a drive blank.
5. Observe the EMU to ensure the error is corrected.
6. If unable to correct the problem, contact your authorized service representative.

0.1.en.03 INFORMATION condition—Drive software lock active

Some enclosures have a software-activated lock that prevents physically removing a drive while this feature is active. This feature can be activated even when an enclosure does not have a physical lock. Removing a drive when this feature is active generates a condition report. This error remains active for 15 seconds.

No action is required to correct this condition.

0.1.en.04 CRITICAL condition—Loop a drive link rate incorrect

The drive is capable of operating at the loop link rate but is running at a different rate. For example, the drive is operating at 1 Gbps, and the loop is operating at 2 Gbps. Only when the drive is operating at the Fibre Channel link rate established by the I/O module can this drive transfer data.

This error remains active until the problem is corrected.

Complete the following procedure to correct this problem:

1. Record all six characters of the condition report.
2. Remove and replace the drive in the enclosure.
3. Observe the drive status indicators to ensure the drive is operational.
4. Observe the EMU to ensure the error is corrected.
5. If removing and replacing the drive did not correct the problem, replace the drive.
6. Observe the drive status indicators to ensure the drive is operational.
7. Observe the EMU to ensure the error is corrected.
8. If unable to correct the problem, contact your authorized service representative.

0.1.en.05 CRITICAL condition—Loop b drive link rate incorrect

The drive is capable of operating at the loop link rate but is running at a different rate. For example, the drive is operating at 1 Gbps, and the loop is operating at 2 Gbps. Only when the drive is operating at the Fibre Channel link rate established by the I/O module can this drive transfer data.

This error remains active until the problem is corrected.

Complete the following procedure to correct this problem:

1. Record all six characters of the condition report.
2. Remove and replace the drive in the enclosure.
3. Observe the drive status indicators to ensure the drive is operational.
4. Observe the EMU to ensure the error is corrected.
5. If removing and replacing the drive did not correct the problem, replace the drive.
6. Observe the drive status indicators to ensure the drive is operational.
7. Observe the EMU to ensure the error is corrected.
8. If unable to correct the problem, contact your authorized service representative.

Power supply conditions

The format of a power supply condition report is *0.2.en.ec*, where:

- *0.2.* is the power supply element type number
- *en.* is the two-character power supply element number
- *ec* is the error code

Figure 57 shows the location of power supply 1 and power supply 2.

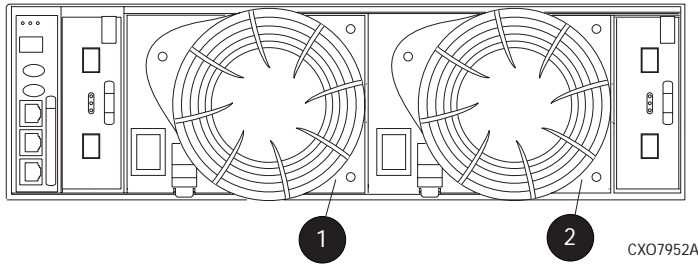

Figure 57 Power supply element numbering

The following sections define the power supply condition reports.

0.2.en.01 NONCRITICAL Condition—Power supply AC input missing

The loss of the AC input to a power supply makes the remaining power supply a single point of failure.

This condition report remains active until AC power is applied to the power supply.

Complete the following procedure to correct this problem:

1. Record all six characters of the condition report.
2. Ensure that there is AC power to the rack PDU, and from the PDU to the PDMs and that the PDU and PDM circuit breakers are not reset.

If there is no AC power to the PDU, contact building facilities management.

Verify that the power supply AC power cord is properly connected.

3. If AC is present, and the rack power distribution circuitry is functioning properly, the power supply indicator should be on.
4. Observe the EMU to ensure the error is corrected.
5. Contact your authorized service representative.

0.2.en.02 UNRECOVERABLE condition—Power supply missing

This condition report indicates a power supply is not installed or installed incorrectly. Both of these conditions affect air flow within the enclosure and can cause an overtemperature condition. Enclosure shutdown is imminent.

The operational power supply will automatically shut down after seven minutes, thereby disabling the enclosure. This condition report remains active until either the problem is corrected, or the operational power supply shuts down, whichever occurs first.

To correct this problem, record all six characters of the condition report, then contact your authorized service representative.

△ CAUTION:

Removing power from an enclosure may cause the loss or corruption of data. To avoid this condition, shut down the system using HP Command View EVA. An automatic shutdown and possible data corruption may result if the power supply is removed before a replacement is available.

0.2.en.03 CRITICAL condition—Power supply load unbalanced

This condition report indicates that a component within a power supply may have failed. This can make the remaining power supply a single point of failure.

This condition report remains active until corrected.

Complete the following procedure to correct this problem:

1. Record all six characters of the condition report.
2. Ensure that the **blower** on the power supply is functioning properly. If not, correct the blower condition and wait one minute.
3. Contact your authorized service representative.

Blower conditions

The format of a **blower** condition report is *0.3.en.ec*, where:

- *0.3.* is the **blower** element type number
- *en.* is the two-character **blower** element number
- *ec* is the error code

As shown in [Figure 58](#), **blower** 1 is in location 1 and blower 2 is in location 2.

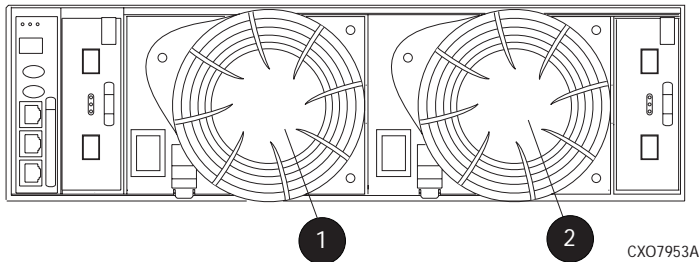

Figure 58 Blower element numbering

△ CAUTION:

A single **blower** operating at high speed can provide sufficient air flow to cool an enclosure and the elements for up to 100 hours. However, operating an enclosure at temperatures approaching an overheating threshold can damage elements and may reduce the MTBF of a specific element. Immediate replacement of the defective blower is required.

The following sections define the power supply condition reports.

0.3.en.01 NONCRITICAL condition—Blower speed

A **blower** is operating at a speed outside of the EMU specified range, possibly because of a bearing problem. This can affect enclosure cooling and cause an element to fail. This condition report remains active until the problem is corrected.

This error does not normally require immediate correction. However, an error of this type could contribute to an element overheating.

HP recommends replacing the **blower** as soon as possible.

To correct this problem, record all six characters of the condition report, then contact your HP authorized service representative.

0.3.en.02 CRITICAL condition—Blower speed

A **blower** is operating at a speed that is significantly outside the EMU specified range, possibly because of a bearing problem. This can cause the loss of cooling and cause an element to fail. The error remains active until the problem is corrected.

HP recommends replacing the **blower** as soon as possible.

To correct this problem, record all six characters of the condition report, then contact your authorized service representative.

0.3.en.03 UNRECOVERABLE condition—Blower failure

A **blower** has stopped. The operational blower now operates at high speed and is a single point of failure. This condition report remains active until the problem is corrected.

To correct this problem, record all six characters of the condition report, then contact your authorized service representative.

0.3.en.04 UNRECOVERABLE condition—Blower internal

A power supply reported an internal **blower** error that could affect enclosure cooling and cause an element to fail. HP recommends correcting the problem before the blower fails. This condition report remains active until the problem is corrected.

To correct this problem, record all six characters of the condition report, then contact your HP authorized service representative.

0.3.en.05 NONCRITICAL condition—Blower missing

A **blower** has been removed or is improperly installed. Even though the blower flaps close to maintain the proper air flow, the reduced cooling capability can cause overheating, causing an element to fail. This condition report remains active until the problem is corrected.

To correct this problem, record all six characters of the condition report, then contact your HP authorized service representative.

0.3.en.06 UNRECOVERABLE condition—No blowers installed

NOTE:

IMPORTANT

When this condition exists there will be two error messages.

The first message will be *0.3.en.05* and will identify the first **blower**.

The second message will be *0.3.en.06* and will identify the second **blower**.

The EMU cannot detect any installed **blowers**. *Shutdown is imminent!* The EMU will shut down the enclosure in *seven minutes* unless you correct the problem. This condition report remains active until you correct the problem or the EMU shuts down the power supplies, whichever occurs first.

Complete the following procedure to correct this problem.

1. Record all six characters of the condition report.
 2. Use the controller shutdown procedure to shut down the controllers.
 3. Contact your authorized service representative.
-

CAUTION:

An automatic shutdown and possible data corruption may result if the **blower** is removed before a replacement is available.

Temperature conditions

The format of a temperature condition report is *0.4.en.ec*, where:

- *0.4.* is temperature sensor element type
- *en.* is the two-character temperature sensor element
- *ec* is the error code

Refer to [Table 41](#) to determine the location of each temperature sensor.

Table 41 Temperature sensor element numbering

Sensor	Sensor location	Sensor	Sensor location
01.	Power Supply 1 Exhaust	10.	Drive Bay 7
02.	Power Supply 2 Exhaust	11.	Drive Bay 8
03.	EMU	12.	Drive Bay 9
04.	Drive Bay 1	13.	Drive Bay 10
05.	Drive Bay 2	14.	Drive Bay 11
06.	Drive Bay 3	15.	Drive Bay 12
07.	Drive Bay 4	16.	Drive Bay 13
08.	Drive Bay 5	17.	Drive Bay 14
09.	Drive Bay 6		

The following sections list the temperature condition reports and the default temperature thresholds. Use HP Command View EVA to view the temperature sensor ranges for the disk drives, EMU, and power supplies.

0.4.en.01 NONCRITICAL condition—High temperature

This condition report indicates that an element temperature is approaching, but has not reached, the high temperature CRITICAL threshold. Continued operation under these conditions may result in a CRITICAL condition. This condition report remains active until the problem is corrected.

Complete the following procedure to correct this problem.

1. Record all six characters of the condition report.
2. Ensure that all elements are properly installed to maintain proper air flow.
3. Ensure that nothing is obstructing the air flow at either the front of the enclosure or the rear of the blower.
4. Ensure that both blowers are operating properly (the indicators are on) and neither blower is operating at high speed.
5. Verify that the ambient temperature range is +10 °C to +35 °C (+50 °F to +95 °F). Correct the ambient conditions.
6. Observe the EMU to ensure the error is corrected.
7. If unable to correct the problem, contact your authorized service representative.

0.4.en.02 CRITICAL condition—High temperature

This condition report indicates that an element temperature is above the high temperature CRITICAL threshold. Continued operation under these conditions may result in element failure and may reduce an element MTBF. This condition report remains active until the problem is corrected.

Complete the following procedure to correct this problem.

1. Record all six characters of the condition report.
2. Ensure that all elements are properly installed to maintain proper air flow.
3. Ensure that nothing is obstructing the air flow at either the front of the enclosure or the rear of the blower.
4. Ensure that both blowers are operating properly (the indicators are on) and neither blower is operating at high speed.

5. Verify that the ambient temperature range is +10 °C to +35 °C (+50 °F to +95 °F). Adjust as necessary.
6. Observe the EMU to ensure the error is corrected.
7. If unable to correct the problem, contact your authorized service representative.

0.4.en.03 NONCRITICAL condition—Low temperature

This condition report indicates that an element temperature is approaching, but has not reached, the low temperature CRITICAL threshold. Continued operation under these conditions may result in a CRITICAL condition. This condition report remains active until the problem is corrected.

Complete the following procedure to correct this problem.

1. Record all six characters of the condition report.
2. Verify that the ambient temperature range is +10 °C to +35 °C (+50 °F to +95 °F). Adjust as necessary.
3. Observe the EMU to ensure the error is corrected.
4. If the ambient temperature is correct and the problem persists, contact your Authorized Service Representative.

0.4.en.04 CRITICAL condition—Low temperature

This condition report indicates that an element temperature has reached the low temperature CRITICAL threshold. HP recommends correcting this error to prevent affecting other elements. This condition report remains active until the problem is corrected.

Complete the following procedure to correct this problem.

1. Record all six characters of the condition report.
2. Verify that the ambient temperature range is +10 °C to +35 °C (+50 °F to +95 °F). Adjust as necessary.
3. Observe the EMU to ensure the error is corrected.
4. If the ambient temperature is correct and the problem persists, contact your authorized service representative.

0.4.en.05 UNRECOVERABLE condition—High temperature

This condition report indicates that the EMU has evaluated the temperature of the three temperature groups (EMU, disk drives, and power supplies), and determined that the average temperature of two of the three groups exceeds the critical level (use HP Command View EVA to view the temperature thresholds). Under these conditions the EMU starts a timer that will automatically shut down the enclosure in seven minutes unless you correct the problem. *Enclosure shutdown is imminent!*

△ CAUTION:

An automatic shutdown and possible data corruption may result if the procedure below is not performed *immediately*.

Complete the following procedure to correct this problem.

1. Ensure that all disk drives, I/O modules, and power supply elements are fully seated.
2. Ensure that all blowers are operating properly.
3. Verify that the ambient temperature range is +10 °C to +35 °C (+50 °F to +95 °F). Adjust as necessary.
4. If steps 1, 2 or 3 did not reveal a problem, use HP Command View EVA to request the HSV controller to shut down the drive enclosure. Completing this action will halt the drive enclosure data transfers.

5. Contact your authorized service representative and request assistance.

EMU conditions

The format of an EMU condition report is *0.7.01.ec*, where:

- *0.7.* is the EMU element type number
- *01.* is the two-character EMU element number
- *ec* is the error code

 **NOTE:**

There is only one EMU in a drive enclosure. Therefore, the element number is always 01.

Resetting the EMU

In some cases, the only corrective action for an EMU error is to replace the EMU. Call your authorized service representative if this action is required. Another option is to reset the EMU using the following procedure.

1. Firmly grasp the EMU mounting handle and pull the EMU partially out of the enclosure.

 **NOTE:**

You do not need to remove the EMU from the enclosure or disconnect the cables. You must avoid putting any strain on the cables or connectors.

2. Wait 30 seconds, and then push the EMU in and fully seat the element in the [backplane](#). The EMU should display any enclosure condition report within two minutes.

07.01.01 CRITICAL condition—EMU internal clock

There is an internal EMU clock error that will remain active until the problem is corrected.

Complete the following procedure to correct this problem.

1. Record all six characters of the condition report.
2. Reset the EMU.
3. If resetting the EMU did not correct the problem, replace the EMU.
4. Observe the EMU to ensure the error is corrected.
5. If unable to correct the problem, contact your HP authorized service representative.

07.01.02 UNRECOVERABLE condition—EMU interrupted

The Inter-IC (I2C) bus is not processing data and the EMU is unable to monitor or report the status of the elements or enclosures. *IMMEDIATE* corrective action is required to ensure proper enclosure operation. This condition report remains active until the problem is corrected.

Complete the following procedure *NOW* to correct this problem.

1. Record all six characters of the condition report.
2. Reset the EMU.
3. Observe the EMU to ensure the error is corrected.
4. If resetting the EMU did not correct the problem, replace the EMU.
5. If unable to correct the problem, contact your HP authorized service representative.

0.7.01.03 UNRECOVERABLE Condition—Power supply shutdown

This message only appears in HP Command View EVA to report a power supply has already shut down. This message can be the result of the controller shutdown command or an EMU or power supply initiated power shutdown.

This message cannot be displayed until after restoration of power. Therefore, there is no corrective action required.

0.7.01.04 INFORMATION condition—EMU internal data

The EMU is unable to collect data for the SCSI-3 Engineering Services (SES) page. This condition report remains active for 15 seconds. The condition report affects only internal EMU operations. There is no degradation of enclosure operations.

The EMU initiates automatic recovery procedures.

If the problem is not automatically corrected after one minute, contact your HP authorized service representative.

0.7.01.05 UNRECOVERABLE condition—Backplane NVRAM



NOTE:

IMPORTANT

Backplane NVRAM errors usually occur during manufacture. At this time they are identified and corrected. They rarely occur during normal operation.

When a **backplane** NVRAM is not programmed or cannot be read by the EMU, there is no communication with the disk drives. This condition report remains active until the problem is corrected.

Complete the following procedure to correct this problem.

1. Record all six characters of the condition report.
2. Reset the EMU.
3. Observe the EMU to ensure the error is corrected.
4. If resetting the EMU did not correct the problem, contact your HP authorized service representative.

0.7.01.10 NONCRITICAL condition—NVRAM invalid read data

The data read from the EMU NVRAM is invalid. This error initiates an automatic recovery process. This condition report remains active until the problem is corrected.

If the automatic recovery process does not correct the problem, complete the following procedure.

1. Record all six characters of the condition report.
2. Reset the EMU.
3. Observe the EMU to ensure the error is corrected.
4. If resetting the enclosure did not correct the problem, contact your HP authorized service representative.

0.7.01.11 NONCRITICAL condition—EMU NVRAM write failure

The EMU cannot write data to the NVRAM. This condition report remains active until the problem is corrected.

Complete the following procedure to correct this problem:

1. Record all six characters of the condition report.

2. Reset the EMU.
3. Observe the EMU to ensure the error is corrected.
4. If resetting the enclosure did not correct the problem, contact your HP authorized service representative.

0.7.01.12 NONCRITICAL condition—EMU cannot read NVRAM data

The EMU is unable to read data from the NVRAM. This condition report remains active until the problem is corrected.

Complete the following procedure to correct this problem:

1. Record all six characters of the condition report.
2. Reset the EMU.
3. Observe the EMU to ensure the error is corrected.
4. If resetting the enclosure did not correct the problem, contact your HP authorized service representative.

0.7.01.13 UNRECOVERABLE condition—EMU load failure

The EMU Field Programmable Gate Array (FPGA) that controls the ESI bus failed to load information required for EMU operation. This condition report remains active until the problem is corrected.

Complete the following procedure to correct this problem:

1. Record all six characters of the condition report.
2. Reset the EMU.
3. Observe the EMU to ensure the error is corrected.
4. If resetting the enclosure did not correct the problem, contact your HP authorized service representative.

0.7.01.14 NONCRITICAL condition—EMU enclosure address

Either the enclosure address is incorrect or the enclosure has no address. Possible causes include a defective enclosure address bus cable, an incorrectly connected cable, or a defective enclosure address bus enclosure ID expansion cable. This condition report remains active until the problem is corrected.

Complete the following procedure to correct this problem:

1. Record all six characters of the condition report.
2. Remove and reconnect the cable between the address bus enclosure ID expansion cable and the EMU.



NOTE:

The EMU display may not display a change in condition for up to 30 seconds.

3. Observe the EMU to ensure the error is corrected.
4. If the problem is not corrected, remove and reinstall the lower and upper terminators, and all the enclosure ID expansion cable-to-enclosure ID expansion cables.
5. Observe the EMU to ensure the error is corrected.
6. Reset the EMU, then observe the EMU to ensure the error is corrected.
7. If resetting the EMU did not correct the problem, contact your HP authorized service representative.

0.7.01.15 UNRECOVERABLE condition—EMU hardware failure

The EMU has detected an internal hardware problem. This condition report remains active until the problem is corrected.

Complete the following procedure to correct this problem:

1. Record all six characters of the condition report.
2. Reset the EMU.
3. Observe the EMU to ensure the error does not recur within the first minute.
4. If the error does recur, contact your HP authorized service representative. The EMU is inoperative and must be replaced as soon as possible.

0.7.01.16 INFORMATION condition—EMU internal ESI data corrupted

The EMU ESI data is corrupted. This condition does not affect any other element and no action is required.

0.7.01.17 UNRECOVERABLE condition—Power shutdown failure

The power supply did not respond to a controller, EMU, or power supply shut down command. Shutting down the supply is required to prevent overheating.

Complete the following procedure to correct the problem:

1. Record all six characters of the condition report.
2. Move the power cord **bail lock 1**, [Figure 59](#), to the left.
3. Disconnect the AC power cord 2 from the supply.

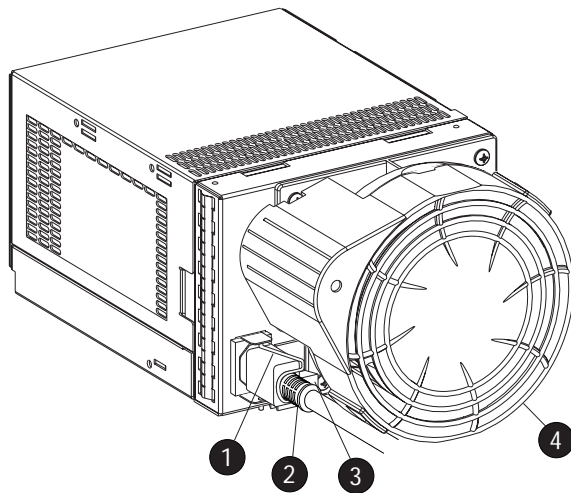

CX07490A

Figure 59 Disconnecting AC power

0.7.01.18 UNRECOVERABLE condition—EMU hardware failure

The EMU has detected an internal hardware problem. This condition report remains active until the problem is corrected.

Complete the following procedure to correct this problem:

1. Record all six characters of the condition report.
2. Reset the EMU.
3. Observe the EMU to ensure the error does not recur within the first minute.

4. If the error does recur, contact your HP authorized service representative. The EMU is inoperative and must be replaced as soon as possible.

0.7.01.19 UNRECOVERABLE condition—EMU ESI driver failure

The EMU has detected an internal hardware problem. This condition report remains active until the problem is corrected.

Complete the following procedure to correct this problem:

1. Record all six characters of the condition report.
2. Reset the EMU.
3. Observe the EMU to ensure the error does not recur within the first minute.
4. If the error does recur, contact your HP authorized service representative. The EMU is inoperative and must be replaced as soon as possible.

Transceiver conditions

The format of a transceiver condition report is *O.F.en.ec*, where:

- *O.F.* is the transceiver element type number
- *en.* is the two-character transceiver element number (see [Figure 60](#))
- *ec* is the error code

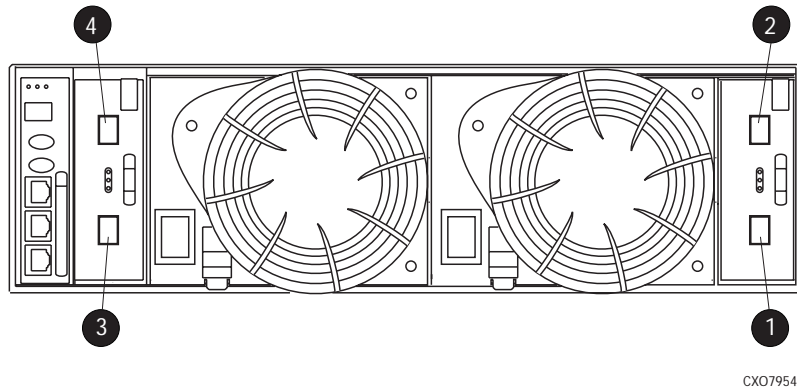

Figure 60 Transceiver element numbering

- | | |
|-------------------|-------------------|
| 1. Transceiver 01 | 2. Transceiver 02 |
| 3. Transceiver 03 | 4. Transceiver 04 |

0.F.en.01 CRITICAL condition—Transceiver incompatibility

The transceivers on this link are not the same type or they are incompatible with the I/O module. This error prevents the controller from establishing a link with the enclosure disk drives and eliminates the enclosure dual-loop capability. This error remains active until the problem is corrected.

To correct this problem, record all six characters of the condition report, then contact your HP authorized service representative.

0.F.en.02 CRITICAL condition—Transceiver data signal lost

This symptom can occur when a controller has been powered off or a cable has been removed from the transceiver. The transceiver can no longer detect a data signal. This error prevents the controller from transferring data on a loop and eliminates the enclosure dual-loop capability. This error remains active until the problem is fixed.

To correct this problem, record all six characters of the condition report, then contact your HP authorized service representative.

0.F.en.03 CRITICAL condition—Transceiver fibre channel drive enclosure bus fault

The system has detected a Fibre Channel drive enclosure bus fault involving a transceiver. This error prevents the controller from transferring data on a loop and eliminates the enclosure dual-loop capability.

Complete the following procedure to correct this problem:

1. Record all six characters of the condition report.
2. Check all the transceivers and cables to ensure they are properly connected.
3. Check all the transceivers on the loop to ensure they are compatible with the I/O module.
4. If the problem persists, contact your HP authorized service representative.

0.F.en.04 CRITICAL condition—Transceiver removed

The EMU detects that a transceiver has been removed. This error remains active until the problem is fixed.

The error can be cleared by doing one of the following:

1. Install a new transceiver,
or
Reconfigure the system by changing from a loop topology to one with Vixel es, then the transceiver is not necessary.
2. Clear the error by resetting the EMU or by removing and then re-installing the I/O module.

0.F.en.05 CRITICAL condition—Invalid fibre channel character

This symptom can occur under the following conditions:

- The incoming data stream is corrupted.
- A cable is not completely connected.
- The signal is degraded.

This error prevents the controller from transferring data on a loop and eliminates the enclosure dual-loop capability. This error remains active until the problem is fixed.

To correct this problem, record all six characters of the condition report, then contact your HP authorized service representative.

Voltage sensor and current sensor conditions

The format of these sensor condition reports is *1.2.en.ec* for a voltage sensor, and *1.3.en.ec* for a current sensor, where:

- *1.2.* is the voltage sensor element type
- *1.3.* is the current sensor element type number
- *en.* is the sensor element number
- *ec* is the error code

Table 42 lists the location of the power supply voltage and current sensors.

Table 42 Voltage and current sensor locations

Sensor	Sensor Element Location
01.	Power Supply 1 +5 VDC
02.	Power Supply 1 +12 VDC
03.	Power Supply 2 +5 VDC
04.	Power Supply 2 +12 VDC

Use HP Command View EVA to view the voltage and current error thresholds for both +5 VDC and +12 VDC power supplies.

1.2.en.01 NONCRITICAL condition—High voltage

This condition report indicates that an element voltage is approaching, but has not reached, the high voltage CRITICAL threshold. Continued operation under these conditions may result in a CRITICAL condition. This condition report remains active until the problem is corrected.

To correct this problem, record all six characters of the condition report, then contact your HP authorized service representative.

1.2.en.02 CRITICAL condition—High voltage

This condition report indicates that an element voltage has reached the high voltage CRITICAL threshold. This report remains active until the problem is corrected.

To correct this problem, record all six characters of the condition report, then contact your HP authorized service representative.

1.2.en.03 NONCRITICAL condition—Low voltage

This condition report indicates that an element voltage is approaching, but has not reached, the low voltage CRITICAL threshold. Continued operation under these conditions may result in a CRITICAL condition. This condition report remains active until the problem is corrected.

To correct this problem, record all six characters of the condition report, then contact your HP authorized service representative.

1.2.en.04 CRITICAL condition—Low voltage

This condition report indicates that an element voltage has reached the low voltage CRITICAL threshold. This condition report remains active until the problem is corrected.

To correct this problem, record all six characters of the condition report, then contact your HP authorized service representative.

1.3.en.01 NONCRITICAL condition—High current

This condition report indicates that an element current is approaching, but has not reached, the high current CRITICAL threshold. Continued operation under these conditions may result in a CRITICAL condition. This condition report remains active until the problem is corrected.

To correct this problem, record all six characters of the condition report, then contact your HP authorized service representative.

1.3.en.02 CRITICAL condition—High current

This condition report indicates that an element current has reached the high current CRITICAL threshold. This condition report remains active until the problem is corrected.

To correct this problem, record all six characters of the condition report, then contact your HP authorized service representative.

Backplane conditions

IMPORTANT:

Backplane NVRAM errors usually occur during manufacture. At this time they are identified and corrected. They rarely occur during normal operation.

The format of a **backplane** condition report is *8.2.01.ec*, where:

- *8.2.* is the **backplane** element type number
- *01.* is the two-character **backplane** element number
- *ec* is the error code

The only corrective action available for this error is to replace the drive enclosure.

8.2.01.10 NONCRITICAL condition—Backplane NVRAM read

An invalid NVRAM read occurred and an automatic recovery process has begun. This condition report is active for 15 seconds.

If the automatic recovery process does not correct the problem, record all six characters of the condition report, then contact your HP authorized service representative.

8.2.01.11 NONCRITICAL condition—Backplane NVRAM write failure

The system is unable to write data to the NVRAM. This problem prevents communication between elements in the enclosure. This condition report is active for 15 seconds.

To correct this problem, record all six characters of the condition report, then contact your HP authorized service representative.

8.2.01.12 NONCRITICAL condition—Backplane NVRAM read failure

The system is unable to read data from the NVRAM. This problem prevents communication between elements in the enclosure. This condition report is active for 15 seconds.

To correct this problem, record all six characters of the condition report, then contact your HP authorized service representative.

8.2.01.13 NONCRITICAL condition—Backplane WWN is blank

The system is unable to read valid data from the NVRAM. This report is active until corrected. This condition can result in incorrect device location data being displayed.

To correct this problem, record all six characters of the condition report, then contact your HP authorized service representative.

I/O Module conditions

The format of an I/O module condition report is *8.7.en.ec*, where:

- *8.7.* is the I/O module element type number
- *en.* is the two-character I/O module element number (see [Figure 61](#))
- *ec* is the error code

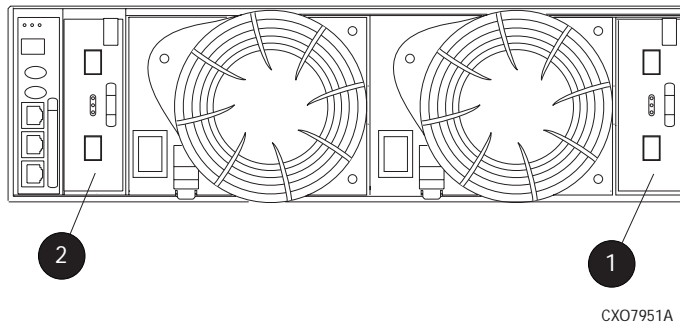

Figure 61 I/O module element numbering

1. I/O Module A (01)
2. I/O Module B (02)

Correction of an I/O module problem normally requires replacing the module. The following sections define the I/O module problem by I/O module location.

8.7.en.01 CRITICAL condition—I/O module unsupported

The I/O module Fibre Channel link speed is not supported by the [backplane](#). This error prevents the controller from establishing a link with enclosure drives and eliminates the enclosure dual-loop capability. This condition report remains active until the problem is corrected.

To correct this problem, record all six characters of the condition report, then contact your HP authorized service representative.

8.7.en.02 CRITICAL condition—I/O module communication

The I/O module is unable to communicate with the EMU.

Complete the following procedure to correct this problem:

1. Record all six characters of the condition report.
2. Contact your HP authorized service representative.

 **IMPORTANT:**

Multiple erroneous error messages indicating I2C bus errors, such as NVRAM errors, blowers missing, and so forth, could indicate an EMU problem.

8.7.en.10 NONCRITICAL condition—I/O module NVRAM read

An invalid NVRAM read occurred and automatic recovery was initiated.

Complete the following procedure to correct this problem:

1. Record all six characters of the condition report.
2. Observe the I/O module status indicators for an operational display.
3. Contact your HP authorized service representative.

8.7.en.11 NONCRITICAL condition—I/O module NVRAM write

The system is unable to write data to the I/O module NVRAM.

Complete the following procedure to correct this problem:

1. Record all six characters of the condition report.
2. Observe the I/O module status indicators for an operational display.

3. Contact your HP authorized service representative.

8.7.en.12 NONCRITICAL condition—I/O Module NVRAM read failure

The system is unable to read data from the I/O module NVRAM.

Complete the following procedure to correct this problem:

1. Record all six characters of the condition report.
2. Contact your HP authorized service representative.

8.7.en.13 NONCRITICAL condition—I/O module removed

The system detects that an I/O module has been removed.

To correct the problem, install an I/O module.

Host conditions

The EMU has the capability of displaying host controller defined condition reports on the EMU alphanumeric display.

The format of a host condition report is *F.F.en.ec*, where:

- *F.F.* is the host element type number
- *en.* is the two-character host element number
- *ec* is the error code

The host controller can display host controller defined error codes on the EMU alphanumeric display

C Controller fault management

This appendix describes how the controller displays events and termination event information. Termination event information is displayed on the LCD. HP Command View EVA enables you to view controller events. This appendix also discusses how to identify and correct problems.

Once you create a storage system, an error condition message has priority over other controller displays.

HP Command View EVA provides detailed descriptions of the storage system error conditions, or faults. The Fault Management displays provide similar information on the LCD, but not in as much detail. Whenever possible, refer to HP Command View EVA for fault information.

Using HP Command View EVA

HP Command View EVA provides detailed information about each event affecting system operation in either a Termination Event display or an Event display. These displays are similar, but not identical.

GUI termination event display

A problem that generates the Termination Event display prevents the system from performing a specific function or process. You can use the information in this display (see [GUI Termination Event Display](#)) to diagnose and correct the problem.

NOTE:

The major differences between the Termination Event display and the Event display are:

- The Termination Event display includes a Code Flag field; it does not include the EIP Type field.
- The Event display includes an EIP type field; it does not include a Code Flag field.
- The Event display includes a Corrective Action Code field.

Date	Time	SWCID	Evt No	Code Flag	Description
------	------	-------	--------	-----------	-------------

Figure 62 GUI termination event display

The fields in the Termination Event display include:

- Date—The date the event occurred.
- Time—The time the event occurred.
- SWCID—Software Identification Code. A hexadecimal number in the range 0–FF that identifies the controller software component reporting the event.
- Evt No—Event Number. A hexadecimal number in the range 0–FF that is the software component identification number.
- Code Flag—An internal code that includes a combination of other flags.
- Description—The condition that generated the event. This field may contain information about an individual field's content and validity.

GUI event display

A problem that generates the Event display reduces the system capabilities. You can use the information in this display (see [Figure 63](#)) to diagnose and correct problems.

 **NOTE:**

The major differences between the Event Display and the Termination Event display are:

- The Event display includes an EIP type field; it does not include a Code Flag field.
- The Event display includes a Corrective Action Code (CAC) field.
- The Termination Event display includes a Code Flag field; it does not include the EIP Type field.

Date	Time	SWCID	Evt No	CAC	EIP Type	Description
------	------	-------	--------	-----	----------	-------------

Figure 63 Typical HP Command View EVA Event display

The Event display provides the following information:

- Date—The date the event occurred.
- Time—The time the even occurred.
- SWCID—Software Identification Code. A number in the range 1–256 that identifies the internal firmware module affected.
- Evt No—Event Number. A hexadecimal number in the range 0–FF that is the software component identification number.
- CAC—Corrective Action Code. A specific action to correct the problem.
- EIP Type—Event Information Packet Type. A hexadecimal character that defines the event information format.
- Description—The problem that generated the event.



Fault management displays

When you do not have access to the GUI, you can display and analyze termination codes (TCs) on the OCP LCD display. You can then use the event text code document, as described in the section titled “Interpreting Fault Management Information” to determine and implement corrective action. You can also provide this information to the authorized service representative should you require additional support. This lets the service representative identify the tools and components required to correct the condition in the shortest possible time.

When the fault management display is active, you can either display the last fault or display detailed information about the last 32 faults reported.

Displaying Last Fault Information

Complete the following procedure to display Last Fault information

1. When the Fault Management display is active, press  to select the Last Fault menu.
2. Press  to display the last fault information.

The first line of the TC display contains the eight-character TC error code and the two-character IDX (index) code. The IDX is a reference to the location in the TC array that contains this error. The second line of the TC display identifies the affected parameter with a two-character parameter number (0–30), the eight-character parameter code affected, and the parameter code number.

3. Press  to return to the Last Fault menu.

Displaying Detailed Information

The Detail View menu lets you examine detailed fault information stored in the Last Termination Event Array (LTEA). This array stores information for the last 32 termination events.

Complete the following procedure to display the LTEA information about any of the last 32 termination events:

1. When the Fault Management display is active (flashing), press ▼ to select the Detail View menu. The LTEA selection menu is active (LTEA 0 is displayed).
2. Press ▼ or ▲ to increment to a specific error.
3. Press ▶ to observe data about the selected error.

Interpreting fault management information

Each version of HP Command View EVA includes an ASCII text file that defines all the codes that the authorized service representative can view either on the GUI or on the OCP.

IMPORTANT:

This information is for the exclusive use of the authorized service representative.

The file name identifies the controller model, file type, XCS baselevel id, and XCS version. For example, the file name *hsv210_event_cr08d3_5020.txt* provides the following information:

- *hsv210_*—The EVA controller model number
- *event_*—The type of information in the file
- *w010605_*—the base level build string (the file creation date).
 - 01—creation year
 - 06—creation month
 - 05—creation date
- 5020—The XCS version

Table 43 describes types of information available in this file.

Table 43 Controller event text description file

Information type	Description
Event Code	This hexadecimal code identifies the reported event type.
Termination Code (TC)	The hexadecimal code specifies the condition that generated the termination code. It might also define either a system or user initiated corrective action.
Coupled Crash Control Codes	This single digit, decimal character defines the requirement for the other controller to initiate a coupled crash control.0. Other controller SHOULD NOT complete a coupled crash.1. Other controller SHOULD complete a coupled crash.
Dump/Restart Control Codes	This single decimal character (0, 1, 3) defines the requirement to:0. Perform a crash dump and then restart the controller.1. DO NOT perform a crash dump; just restart the controller.3. DO NOT perform a crash dump; DO NOT restart the controller
Corrective Action Codes (CAC)	These hexadecimal codes supplement the Termination Code information to identify the faulty element and the recommended corrective action.
Software Component ID Codes (SWCID)	These decimal codes identify software associated with the event.
Event Information Packets (EIP)	These codes specify the packet organization for specific type events.

D Non-standard rack specifications

The appendix provides information on the requirements when installing the EVA4000/6000/8000 in a non-standard rack. All the requirements must be met to ensure proper operation of the storage system.

Rack specifications

Internal component envelope

EVA component mounting brackets require space to be mounted behind the vertical mounting rails. Room for the mounting of the brackets includes the width of the mounting rails and needed room for any mounting hardware, such as screws, clip nuts etc. [Figure 64](#) shows the dimensions required for the mounting space for the EVA product line. It does not show required space for additional HP components such as servers.

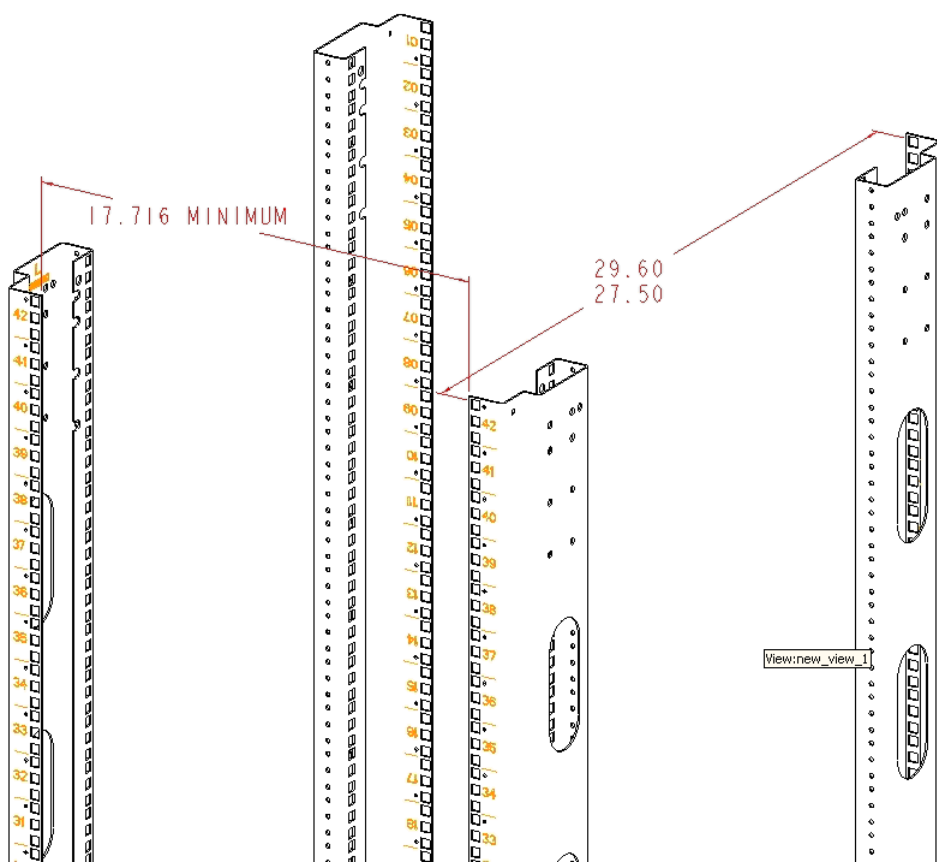

Figure 64 Mounting space dimensions

EIA310-D standards

The rack must meet the Electronic Industries Association, (EIA), Standard 310-D, Cabinets, Racks and Associated Equipment. The standard defines rack mount spacing and component dimensions specified in U units.

Copies of the standard are available for purchase at <http://www.eia.org/>

EVA cabinet measures and tolerances

EVA component rack mount brackets are designed to fit cabinets with mounting rails set at depths from 27.5 inches to 29.6 inches, inside rails to inside rails.

Weights, dimensions and component CG measurements

Cabinet CG dimensions are reported as measured from the inside bottom of the cabinet (Z), the leading edge of the vertical mounting rails (Y), and the centerline of the cabinet mounting space (X). Component CG measurements are measured from the bottom of the U space the component is to occupy (Z), the mounting surface of the mounting flanges (Y), and the centerline of the component (X). Table 44 lists the CG dimensions for the EVA components.

Determining the CG of a configuration may be necessary for safety considerations. CG considerations for CG calculations do not include cables, PDU's and other peripheral components. Some consideration should be made to allow for some margin of safety when estimating configuration CG.

Estimating the configuration CG requires measuring the CG of the cabinet the product will be installed in. Use the following formula:

$$\sum d_{\text{component}} W = d_{\text{system cg}} W$$

where $d_{\text{component}}$ = the distance of interest and W = Weight

The distance of a component is its CG's distance from the inside base of the cabinet. For example, if a loaded disk enclosure is to be installed into the cabinet with its bottom at 10U, the distance for the enclosure would be $(10 \times 1.75) + 2.7$ inches.

Table 44 Component data

Component Data					
	U height ¹	Weight (Lb)	X (in)	Y (in)	Z (in)
HP 10K cabinet CG		233	-0.108	25.75	14.21
Filler panel , 3U	3	1.4	0	2.625	0
Fully loaded drive enclosure	3	74	-0.288	2.7	7.95
FC loop pair	1	24.6	-0.025	0.365	11.89
Filler panel, 1U	1	0.47	0	0.875	0
XL Controller Pair	4	120(??)	-0.094	2.53	10.64

¹1U = 1.75 inches

Airflow and Recirculation

Component Airflow Requirements

Component airflow must be directed from the front of the cabinet to the rear. Components vented to discharge airflow from the sides must discharge to the rear of the cabinet.

Rack Airflow Requirements

The following requirements must be met to ensure adequate airflow and to prevent damage to the equipment:

- If the rack includes closing front and rear doors, allow 830 square inches (5,350 sq cm) of hole evenly distributed from top to bottom to permit adequate airflow (equivalent to the required 64 percent open area for ventilation).
- For side vented components, the clearance between the installed rack component and the side panels of the rack must be a minimum of 2.75 inches (7 cm).
- Always use blanking panels to fill all empty front panel U-spaces in the rack. This ensures proper airflow. Using a rack without blanking panels results in improper cooling that can lead to thermal damage.

Configuration Standards

EVA configurations are designed considering cable length, configuration CG, serviceability and accessibility and to allow for easy expansion of the system. If at all possible, it is best to configure non HP cabinets in a like manner:

Environmental and operating specifications

This section identifies the product environmental and operating specifications.

Power requirements

The following tables list the wattage and BTU/hour power requirements for the three supported operating voltages.



NOTE:

Failover amperage can be estimated at approximately 90% of operational amperage listed.

Table 45 208V Wattage and BTU/Hour

Enclosures	EVA4000				EVA6000				EVA8000			
	Amps	VA	Watts	BTU/h	Amps	VA	Watts	BTU/h	Amps	VA	Watts	BTU/h
12									24.5	5104	4920	16789
11									22.0	4578	4414	15060
10									20.1	4188	4037	13775
9									18.3	3797	3660	12489
8					16.0	3334	3214	10965	16.4	3406	3284	11204
7					14.1	2943	2837	9680	14.5	3015	2907	9919
6					12.3	2552	2460	8394	12.6	2625	2530	8633
5					10.4	2161	2083	7109	10.7	2234	2153	7348
4	8.2	1698	1637	5585	8.5	1770	1707	5824	8.9	1843	1777	6063
3	6.3	1307	1260	4300	6.6	1380	1330	4538	7.0	1452	1400	4777
2	4.4	916	883	3014	4.8	989	953	3253	5.1	1062	1023	3492
1	2.5	526	507	1729	2.9	598	577	1968	3.2	671	647	2207

Table 46 230V Wattage and BTU/Hour

Enclosures	EVA4000				EVA6000				EVA8000			
	Amps	VA	Watts	BTU/h	Amps	VA	Watts	BTU/h	Amps	VA	Watts	BTU/h
12									21.6	4969	4790	16345
11									19.9	4578	4414	15060
10									18.2	4188	4037	13775
9									16.5	3797	3660	12489
8					14.5	3334	3214	10965	14.8	3406	3284	11204
7					12.8	2943	2837	9680	13.1	3015	2907	9919
6					11.1	2552	2460	8394	11.4	2625	2530	8633
5					9.4	2161	2083	7109	9.7	2234	2153	7348
4	7.4	1698	1637	5585	7.7	1770	1707	5824	8.0	1843	1777	6063
3	5.7	1307	1260	4300	6.0	1380	1330	4538	6.3	1452	1400	4777
2	4.0	916	883	3014	4.3	989	953	3253	4.6	1062	1023	3492
1	2.3	526	507	1729	2.6	598	577	1968	2.9	671	647	2207

Table 47 100V Wattage and BTU/Hour

Enclosures	EVA4000				EVA6000				EVA8000			
	Amps	VA	Watts	BTU/h	Amps	VA	Watts	BTU/h	Amps	VA	Watts	BTU/h
8					35.5	3545	3474	11855	EVA8000 not supported			
7					31.5	3145	3082	10518				
6					27.5	2746	2691	9181				
5					23.5	2346	2299	7845				
4	18.7	1875	1837	6269	19.5	1946	1907	6508				
3	14.8	1475	1446	4933	15.5	1546	1516	5171				
2	10.8	1075	1054	3596	11.5	1147	1124	3835				
1	6.8	676	662	2259	7.5	747	732	2498				

UPS Selection

This section provides information that can be used when selecting a UPS for use with the EVA. The four HP UPS products listed in [Table 48](#) are available for use with the EVA and are included in this comparison. [Table 49](#) identifies the amount of time each UPS can sustain power under varying loads and with various UPS ERM (Extended Runtime Module) options.

The load imposed on the UPS for different disk enclosure configurations are listed in [Table 50](#), [Table 51](#), and [Table 52](#). The load



NOTE:

The specified power requirements reflect fully loaded enclosures (14 disks) .

Table 48 HP UPS models and capacities

UPS Model	Capacity (in watts)
R1500	1340
R3000	2700
R5500	4500
R12000	12000

Table 49 UPS operating time limits

Load (percent)	Minutes of operation		
	With standby battery	With 1 ERM	With 2 ERMs
R1500			
100	5	23	49
80	6	32	63
50	13	57	161
20	34	146	290
R3000			
100	5	20	
80	6.5	30	
50	12	45	
20	40	120	
R5500			
100	7	24	46
80	9	31	60
50	19	61	106
20	59	169	303
R12000			
100	5	11	18
80	7	15	24
50	14	28	41
20	43	69	101

Table 50 EVA 8000 UPS loading

Enclosures	Watts	% of UPS capacity	
		R5500	R12000
12	4920		41.0
11	4414	98.1	36.8
10	4037	89.7	33.6
9	3660	81.3	30.5
8	3284	73.0	27.4
7	2907	64.6	24.2
6	2530	56.2	21.1
5	2153	47.9	17.9
4	1777	39.5	14.8
3	1400	31.1	11.7
2	1023	22.7	8.5
1	647	14.4	5.4

Table 51 EVA 6000 UPS loading

Enclosures	Watts	% of UPS capacity		
		R3000	R5500	R12000
8	3214		71.4	26.8
7	2837		63.0	23.6
6	2460	91.1	54.6	20.5
5	2083	77.2	46.2	17.3
4	1707	63.2	37.9	14.2
3	1330	49.3	29.5	11.1
2	953	35.3	21.2	7.9
1	577	21.4	12.8	4.8

Table 52 EVA 4000 UPS loading

Enclosures	Watts	% of UPS capacity	
		R1500	R3000
4	1637		60.6
3	1260	94.0	46.6
2	883	65.9	32.7
1	507	37.9	18.7

Environmental specifications

Table 53 Environmental specifications

Operating temperature	50° to 95° F (10° to 35° C) - Reduce rating by 1° F for each 1000 ft altitude (1.8° C/1,000 m)
Shipping temperature	-40° to 150° F (-40° to 66° C)
Operating humidity	10% to 90% non-condensing
Shipping humidity	5% to 90% non-condensing
Altitude	Up to 8,000 ft (2,400 m)
Air quality	Not to exceed 500,000 particles per cubic foot of air at a size of 0.5 micron or larger

Shock and vibration specifications

Table 54 lists the product operating shock and vibration specifications. This information applies to products weighing 45 Kg (100 lbs) or less.

NOTE:

HP StorageWorks EVA products are designed and tested to withstand the operational shock and vibration limits specified in Table 54. Transmission of site vibrations through non-HP racks exceeding these limits could cause operational failures of the system components.

Table 54 Operating Shock/Vibration

Shock test with half sine pulses of 10 G magnitude and 10 ms duration applied in all three axes (both positive and negative directions).
Sine sweep vibration from 5 Hz to 500 Hz to 5 Hz at 0.1 G peak, with 0.020" displacement limitation below 10 Hz. Sweep rate of 1 octave/minute. Test performed in all three axes.
Random vibration at 0.25 G rms level with uniform spectrum in the frequency range of 10 to 500 Hz. Test performed for two minutes each in all three axes.
Drives and other items exercised and monitored running appropriate exerciser (UIOX, P-Suite, etc.) with appropriate operating system and hardware.

Glossary

This glossary defines terms used in this guide or related to this product and is not a comprehensive glossary of computer terms.

µm	A symbol for micrometer; one millionth of a meter. For example, 50 µm is equivalent to 0.000050 m.
3U	A unit of measurement representing three “U” spaces. “U” spacing is used to designate panel or enclosure heights. Three “U” spaces is equivalent to 5.25 inches (133 mm). See also rack-mounting unit .
active member of a virtual disk family	An active member of a virtual disk family is a simulated disk drive created by the controllers as storage for one or more hosts. An active member of a virtual disk family is accessible by one or more hosts for normal storage. An active virtual disk member and its snapshot, if one exists, constitute a virtual disk family. An active member of a virtual disk family is the only necessary member of a virtual disk family. See also virtual disk , virtual disk copy , virtual disk family , and snapshot .
adapter	See controller .
AL_PA	Arbitrated Loop Physical Address. A 1-byte value the arbitrated loop topology uses to identify the loop ports. This value becomes the last byte of the address identifier for each public port on the loop.
allocation policy	Storage system rules that govern how virtual disks are created. Allocate Completely and Allocate on Demand are the two rules used in creating virtual disks. <ul style="list-style-type: none">• Allocate Completely—The space a virtual disk requires on the physical disks is reserved, even if the virtual disk is not currently using the space.• Allocate on Demand—The space a virtual disk requires on the physical disks is not reserved until needed.
ambient temperature	The air temperature in the area where a system is installed. Also called intake temperature or room temperature.
ANSI	American National Standards Institute. A non-governmental organization that develops standards (such as SCSI I/O interface standards and Fibre Channel interface standards) used voluntarily by many manufacturers within the United States.
arbitrated loop	A Fibre Channel topology that links multiple ports (up to 126) together on a single shared simplex media. Transmissions can only occur between a single pair of nodes at any given time. Arbitration is the scheme that determines which node has control of the loop at any given moment
arbitrated loop physical address	See AL_PA .
arbitrated loop topology	See arbitrated loop .
array	All the physical disk drives in a storage system that are known to and under the control of a controller pair.

array controller	See controller .
asynchronous	Events scheduled as the result of a signal requesting the event or that which is without any specified time relation.
audible alarm	The Environmental Monitoring Unit (EMU) alarm that sounds when there is a drive enclosure element condition report. The audible alarm can be muted or disabled.
backplane	An electronic printed circuit board that distributes data, control, power, and other signals to element connectors.
bad block	A data block that contains a physical defect.
bad block replacement	A replacement routine that substitutes defect-free disk blocks for those found to have defects. This process takes place in the controller and is transparent to the host.
bail lock	Part of the power supply AC receptacle that engages the AC power cord connector to ensure that the cord cannot be accidentally disconnected.
baud	The maximum rate of signal state changes per second on a communication circuit. If each signal state change corresponds to a code bit, then the baud rate and the bit rate are the same. It is also possible for signal state changes to correspond to more than one code bit so the baud rate may be lower than the code bit rate.
bay	The physical location of an element, such as a drive, I/O module, EMU or power supply in a drive enclosure. Each bay is numbered to define its location.
bidirectional	Also called Bi-Di. The movement of optical signals in opposite directions through a common fiber cable such as the data flow path typically on a parallel printer port. A parallel port can provide two-way data flow for disk drives, scanning devices, FAX operations and even parallel modems.
block	Also called a sector. The smallest collection of consecutive bytes addressable on a disk drive. In integrated storage elements, a block contains 512 bytes of data, error codes, flags, and the block address header.
blower	A variable speed airflow device that pulls air into an enclosure or element. It usually pulls air in from the front and exhausts the heated air out the rear.
cabinet	An alternate term used for a rack.
cable assembly	A fiber optic cable that has connectors installed on one or both ends. General use of these cable assemblies includes the interconnection of multimode fiber optic cable assemblies with either LC or SC type connectors. <ul style="list-style-type: none"> • When there is a connector on only one end of the cable, the cable assembly is referred to as a pigtail. • When there is a connector on each end of the cable, the cable assembly is referred to as a jumper.
CAC	Corrective Action Code. An HP Command View EVA graphical user interface (GUI) display component that defines the action required to correct a problem. See also read cache , write cache , and mirrored cache .
cache	High-speed memory that sets aside data as an intermediate data buffer between a host and the storage media. The purpose of cache is to improve performance.
cache battery	A rechargeable unit mounted within a controller enclosure that supplies back-up power to the cache module in case of primary power shortage.

cache battery indicator	<ol style="list-style-type: none"> 1. An orange light emitting diode (indicator) that illuminates on the controller operator control panel (OCP) to define the status of the HSV Controller cache batteries. 2. An amber status indicator that illuminates on a cache battery. When illuminated, it indicates that one or more cache battery cells have failed and the battery must be replaced with a new battery.
carrier	A drive-enclosure-compatible assembly containing a disk drive or other storage devices.
client	A software program that uses the services of another software program. The HP Command View EVA client is a standard internet browser.
clone	See Virtual Disk Copy .
communication logical unit number (LUN)	See console LUN .
condition report	A three-element code generated by the EMU in the form where e.t. is the element type (a hexadecimal number), en. is the element number (a decimal number), and ec is the condition code (a decimal number).
console LUN	A SCSI-3 virtual object that makes a controller pair accessible by the host before any virtual disks are created. <i>Also called a communication LUN.</i>
console LUN ID	The ID that can be assigned when a host operating system requires a unique ID. The console LUN ID is assigned by the user, usually when the storage system is initialized. See <i>also</i> console LUN .
controller	A hardware/firmware device that manages communications between host systems and other devices. Controllers typically differ by the type of interface to the host and provide functions beyond those the devices support.
controller enclosure	A unit that holds one or more controllers, power supplies, blowers, cache batteries, transceivers, and connectors.
controller event	A significant occurrence involving any storage system hardware or software component reported by the controller to HP Command View EVA.
controller fault indicator	An amber fault indicator that illuminates on the controller OCP to indicate when there is an HSV Controller fault.
controller pair	Two interconnected controller modules which together control the disk enclosures in the storage system.
corrective action code	See CAC .
CRITICAL Condition	A drive enclosure EMU condition that occurs when one or more drive enclosure elements have failed or are operating outside of their specifications. The failure of the element makes continued normal operation of at least some elements in the enclosure impossible. Some enclosure elements may be able to continue normal operations. Only an UNRECOVERABLE condition has precedence. This condition has precedence over NONCRITICAL errors and INFORMATION condition.
CRU	Customer Replaceable Unit. A storage system element that a user can replace without using special tools or techniques, or special training.
customer replaceable unit	See CRU .

data entry mode	The state in which controller information can be displayed or controller configuration data can be entered. On the Enterprise Storage System, the controller mode is active when the LCD on the HSV Controller OCP is Flashing.
default disk group	The first disk group created at the time the system is initialized. The default disk group can contain the entire set of physical disks in the array or just a few of the disks. See also disk group .
Detailed Fault View	An HSV Controller OCP display that permits a user to view detailed information about a controller fault.
device channel	A channel used to connect storage devices to a host I/O bus adapter or intelligent controller.
device ports	Controller pair device ports connected to the storage system's physical disk drive array through the Fibre Channel drive enclosure. Also called a device-side port.
device-side ports	See device ports .
DIMM	Dual Inline Memory Module. A small circuit board holding memory chips.
dirty data	The write-back cached data that has not been written to storage media even though the host operation processing the data has completed.
disk drive	A carrier-mounted storage device supporting random access to fixed size blocks of data.
disk drive blank	A carrier that replaces a disk drive to control airflow within a drive enclosure whenever there is less than a full complement of storage devices.
drive enclosure	A unit that holds storage system devices such as disk drives, power supplies, blowers, I/O modules, transceivers, or EMUs.
drive enclosure event	A significant operational occurrence involving a hardware or software component in the drive enclosure. The drive enclosure EMU reports these events to the controller for processing.
disk failure protection	A method by which a controller pair reserves drive capacity to take over the functionality of a failed or failing physical disk. For each disk group, the controllers reserve space in the physical disk pool equivalent to the selected number of physical disk drives.
disk group	A physical disk drive set or pool in which a virtual disk is created. A disk group may contain all the physical disk drives in a controller pair array or a subset of the array.
disk migration state	A physical disk drive operating state. A physical disk drive can be in a stable or migration state: <ul style="list-style-type: none"> • Stable—The state in which the physical disk drive has no failure nor is a failure predicted. • Migration—The state in which the disk drive is failing, or failure is predicted to be imminent. Data is then moved off the disk onto other disk drives in the same disk group.
disk replacement delay	The time that elapses between a drive failure and when the controller starts searching for spare disk space. Drive replacement seldom starts immediately in case the "failure" was a glitch or temporary condition.
drive blank	See disk drive blank .
drive enclosure	See drive enclosure .
dual-loop	A configuration where each drive is connected to a pair of controllers through two loops. These two Fibre Channel loops constitute a loop pair.

dual power supply configuration	See redundant power configuration .
dynamic capacity expansion	A storage system feature that provides the ability to increase the size of an existing virtual disk. Before using this feature, you must ensure that your operating system supports capacity expansion of a virtual disk (or LUN).
EIA	Electronic Industries Alliance. A standards organization specializing in the electrical and functional characteristics of interface equipment.
EIP	Event Information Packet. The event information packet is an HSV element hexadecimal character display that defines how an event was detected. Also called the EIP type.
electromagnetic interference	See EMI .
electrostatic discharge	See ESD .
element	<ol style="list-style-type: none"> 1. In a drive enclosure, a device such as an EMU, power supply, disk, blower, or I/O module. The object can be controlled, interrogated, or described by the enclosure services process. 2. In the Open SAN Manager, a controllable object, such as the Enterprise storage system.
Command View EVA GUI	The graphical user interface (GUI) through which a user can control and monitor a storage system. HP Command View EVA can be installed on more than one storage management server in a fabric. Each installation is a management agent. The client for the agent is a standard browser.
EMI	Electromagnetic Interference. The impairment of a signal by an electromagnetic disturbance.
EMU	Environmental Monitoring Unit. An element which monitors the status of an enclosure, including the power, air temperature, and blower status. The EMU detects problems and displays and reports these conditions to a user and the controller. In some cases, the EMU implements corrective action.
enclosure	A unit used to hold various storage system devices such as disk drives, controllers, power supplies, blowers, an EMU, I/O modules, or blowers.
enclosure address bus	An Enterprise storage system bus that interconnects and identifies controller enclosures and disk drive enclosures by their physical location. Enclosures within a reporting group can exchange environmental data. This bus uses enclosure ID expansion cables to assign enclosure numbers to each enclosure. Communications over this bus do not involve the Fibre Channel drive enclosure bus and are, therefore, classified as out-of-band communications.
enclosure number (En)	One of the vertical rack-mounting positions where the enclosure is located. The positions are numbered sequentially in decimal numbers starting from the bottom of the cabinet. Each disk enclosure has its own enclosure number. A controller pair shares an enclosure number. If the system has an expansion rack, the enclosures in the expansion rack are numbered from 15 to 24, starting at the bottom.
enclosure services	Those services that establish the mechanical environmental, electrical environmental, and external indicators and controls for the proper operation and maintenance of devices with an enclosure as described in the <i>SES SCSI-3 Enclosure Services Command Set (SES), Rev 8b, American National Standard for Information Services</i> .

Enclosure Services Interface	See ESI .
Enclosure Services Processor	See ESP .
Enterprise Virtual Array	The Enterprise Virtual Array is a product that consists of one or more storage systems. Each storage system consists of a pair of HSV controllers and the disk drives they manage. A storage system within the Enterprise Virtual Array can be formally referred to as an Enterprise storage system, or generically referred to as the storage system.
Enterprise Virtual Array rack	A unit that holds controller enclosures, disk drive enclosures, power distribution supplies, and enclosure address buses that, combined, comprise an Enterprise storage system solution. Also called the Enterprise storage system rack. See also rack .
environmental monitoring unit	See EMU .
error code	The portion of an EMU condition report that defines a problem.
ESD	Electrostatic Discharge. The emission of a potentially harmful static electric voltage as a result of improper grounding.
ESI	Enclosure Services Interface. The SCSI-3 engineering services interface implementation developed for StorageWorks products. A bus that connects the EMU to the disk drives.
ESP	Enclosure Services Processor. An EMU that implements an enclosure's services process.
event	Any significant change in the state of the Enterprise storage system hardware or software component reported by the controller to HP Command View EVA. See also controller event , drive enclosure event , management agent event , and termination event .
Event Information Packet	See EIP .
Event Number	See Evt No.
Evt No.	Event Number. A sequential number assigned to each Software Code Identification (SWCID) event. It is a decimal number in the range 0-255.
exabyte	A unit of storage capacity that is the equivalent of 2 ⁶⁰ bytes or 1,152,921,504,606,846,976 bytes. One exabyte is equivalent to 1,024 petabytes.
fabric	A Fibre Channel fabric or two or more interconnected Fibre Channel es allowing data transmission.
fabric port	A port which is capable of supporting an attached arbitrated loop. This port on a loop will have the AL_PA hexadecimal address 00 (loop ID 7E), giving the fabric the highest priority access to the loop. A loop port is the gateway to the fabric for the node ports on a loop.
failover	The process that takes place when one controller assumes the workload of a failed companion controller. Failover continues until the failed controller is operational.
fan	The variable speed airflow device that cools an enclosure or element by forcing ambient air into an enclosure or element and forcing heated air out the other side. See also blower .

Fault Management Code	See FMC .
Fibre Channel drive enclosure	Fibre Channel Arbitrated Loop. The American National Standards Institute's (ANSI) document that specifies arbitrated loop topology operation.
FC HBA	Fibre Channel Host Bus Adapter. An interchangeable term for Fibre Channel adapter. See also FCA .
FCA	Fibre Channel Adapter. An adapter used to connect the host server to the fabric. Also called a Host Bus Adapter (HBA) or a Fibre Channel Host Bus Adapter (FC HBA). See also FC HBA .
FCC	Federal Communications Commission. The federal agency responsible for establishing standards and approving electronic devices within the United States.
FCP	Fibre Channel Protocol. The mapping of SCSI-3 operations to Fibre Channel.
fiber	The optical media used to implement Fibre Channel.
fiber optics	The technology where light is transmitted through glass or plastic (optical) threads (fibers) for data communication or signaling purposes.
fiber optic cable	A transmission medium designed to transmit digital signals in the form of pulses of light. Fiber optic cable is noted for its properties of electrical isolation and resistance to electrostatic contamination.
fibres	The international spelling that refers to the Fibre Channel standards for optical media.
Fibre Channel	A data transfer architecture designed for mass storage devices and other peripheral devices that require very high bandwidth.
Fibre Channel adapter	See FCA .
Fibre Channel Loop	An enclosure that provides twelve-port central interconnect for Fibre Channel Arbitrated Loops following the ANSI Fibre Channel drive enclosure standard.
field replaceable unit	See FRU .
flush	The act of writing dirty data from cache to a storage media
FMC	Fault Management Code. The HP Command View EVA display of the Enterprise Storage System error condition information.
form factor	A storage industry dimensional standard for 3.5inch (89 mm) and 5.25inch (133 mm) high storage devices. Device heights are specified as low-profile (1inch or 25.4 mm), half-height (1.6inch or 41 mm), and full-height (5.25inch or 133 mm).
FPGA	Field Programmable Gate Array. A programmable device with an internal array of logic blocks surrounded by a ring of programmable I/O blocks connected together through a programmable interconnect.
frequency	The number of cycles that occur in one second expressed in Hertz (Hz). Thus, 1 Hz is equivalent to one cycle per second.
FRU	Field Replaceable Unit. A hardware element that can be replaced in the field. This type of replacement can require special training, tools, or techniques. Therefore, FRU procedures are usually performed only by an Authorized Service Representative.

Gb	Gigabit. A measurement of the rate at which the transfer of bits of data occurs. Sometimes referred to as Gbps. Nominally, a Gb is a transfer rate of 1,000,000,000 (10 ⁹) bits per second. For Fibre Channel transceivers or FC loops the Gb transfer rates are: <ul style="list-style-type: none"> • 1 Gb is a transmission rate of 1,062,500,000 bits per second. • 2 Gb is a transmission rate of 2,125,000,000 bits per second.
GB	Gigabyte. A unit of measurement defining either: <ul style="list-style-type: none"> • A data transfer rate. • A storage or memory capacity of 1,073,741,824 (2³⁰) bytes. See also GBps .
Gbps	Gigabits per second. A measurement of the rate at which the transfer of bits of data occurs. Nominally, a Gb is a transfer rate of 1,000,000,000 (10 ⁹) bits per second. See also Gb .
GBps	Gigabytes per second. A measurement of the rate at which the transfer of bytes of data occurs. A GBps is a transfer rate of 1,000,000,000 (10 ⁹) bytes per second. See also GB .
Giga (G)	The notation to represent 10 ⁹ or 1 billion (1,000,000,000).
gigabaud	An encoded bit transmission rate of one billion (10 ⁹) bits per second.
gigabit	See Gb .
gigabit per second	See Gbps .
graphical user interface	See GUI .
GUI	Graphical User Interface. Software that displays the status of a storage system and allows its user to control the storage system.
HBA	Host Bus Adapter. See also FCA .
host	A computer that runs user applications and uses (or can potentially use) one or more virtual disks created and presented by the controller pair.
Host Bus Adapter	See FCA .
host computer	See host .
host link indicator	The HSV Controller display that indicates the status of the storage system Fibre Channel links.
host ports	A connection point to one or more hosts through a Fibre Channel fabric. A host is a computer that runs user applications and that uses (or can potentially use) one or more of the virtual disks that are created and presented by the controller pair.
host-side ports	See host ports .
hot-pluggable	A method of element replacement whereby the complete system remains operational during element removal or insertion. Replacement does not interrupt data transfers to other elements.
hub	A communications infrastructure device to which nodes on a multi-point bus or loop are physically connected. It is used to improve the manageability of physical cables.

I/O module	Input/Output module. The enclosure element that is the Fibre Channel drive enclosure interface to the host or controller. I/O modules are bus speed specific, either 1 Gb or 2 Gb.
IDX	A 2-digit decimal number portion of the HSV controller termination code display that defines one of 32 locations in the Termination Code array that contains information about a specific event. See also param and TC.
in-band communication	The method of communication between the EMU and controller that utilizes the Fibre Channel drive enclosure bus.
INFORMATION condition	A drive enclosure EMU condition report that may require action. This condition is for information only and does not indicate the failure of an element. All condition reports have precedence over an INFORMATION condition.
initialization	A process that prepares a storage system for use. Specifically, the system binds controllers together as an operational pair and establishes preliminary data structures on the disk array. Initialization also sets up the first disk group, called the default disk group.
input/output module	See I/O module .
intake temperature	See ambient temperature
interface	A set of protocols used between components such as cables, connectors, and signal levels.
JBOD	Just a Bunch of Disks. A number of disks connected to one or more controllers.
K	Kilo. A scientific notation denoting a multiplier of one thousand (1,000).
KB	Kilobyte. A unit of measurement defining either storage or memory capacity. <ol style="list-style-type: none"> 1. For storage, a KB is a capacity of 1,000 (10³) bytes of data. 2. For memory, a KB is a capacity of 1,024 (2¹⁰) bytes of data.
LAN	Local area network. A group of computers and associated devices that share a common communications line and typically share the resources of a single processor or server within a small geographic area.
laser	A device that amplifies light waves and concentrates them in a narrow, very intense beam.
Last Fault View	An HSV Controller display defining the last reported fault condition.
Last Termination Error Array	See LTEA .
LCD	Liquid Crystal Display. The indicator on a panel that is associated with an element. The LCD is usually located on the front of an element.
indicator	Light Emitting Diode. A semiconductor diode, used in an electronic display, that emits light when a voltage is applied to it.
License Key	A WWN-encoded sequence that is obtained from the license key fulfillment Web site.
light emitting diode	See indicator .
link	A connection between ports on Fibre Channel devices. The link is a full duplex connection to a fabric or a simplex connection between loop devices.

logon	Also called login, it is a procedure whereby a user or network connection is identified as being an authorized network user or participant.
loop	See arbitrated loop .
loop ID	Seven-bit values numbered contiguously from 0 to 126 decimal and represent the 127 valid AL_PA values on a loop (not all 256 hexadecimal values are allowed as AL_PA values per Fibre Channel).
loop pair	A Fibre Channel attachment between a controller and physical disk drives. Physical disk drives connect to controllers through paired Fibre Channel arbitrated loops. There are two loop pairs, designated loop pair 1 and loop pair 2. Each loop pair consists of two loops (called loop A and loop B) that operate independently during normal operation, but provide mutual backup in case one loop fails.
LTEA	Last Termination Event Array. A two-digit HSV Controller number that identifies a specific event that terminated an operation. Valid numbers range from 00 to 31.
LUN	Logical Unit Number. A SCSI convention used to identify elements. The host sees a virtual disk as a LUN. The LUN address a user assigns to a virtual disk for a particular host will be the LUN at which that host will see the virtual disk.
management agent	The HP Command View EVA software that controls and monitors the Enterprise storage system. The software can exist on more than one management server in a fabric. Each installation is a management agent.
management agent event	Significant occurrence to or within the management agent software, or an initialized storage cell controlled or monitored by the management agent.
Mb	Megabit. A term defining a data transfer rate. See also Mbps .
MB	Megabyte. A term defining either: <ul style="list-style-type: none"> • A data transfer rate. • A measure of either storage or memory capacity of 1,048,576 (2²⁰) bytes. See also MBps .
Mbps	Megabits per second. A measure of bandwidth or data transfers occurring at a rate of 1,000,000 (10 ⁶) bits per second.
MBps	Megabytes per second. A measure of bandwidth or data transfers occurring at a rate of 1,000,000 (10 ⁶) bytes per second.
mean time between failures	See MTBF .
Mega	A notation denoting a multiplier of 1 million (1,000,000).
metadata	Information that a controller pair writes on the disk array. This information is used to control and monitor the array and is not readable by the host.
micro meter	See µm .
mirrored caching	A process in which half of each controller's write cache mirrors the companion controller's write cache. The total memory available for cached write data is reduced by half, but the level of protection is greater.
mirroring	The act of creating an exact copy or image of data.
MTBF	Mean Time Between Failures. The average time from start of use to first failure in a large population of identical systems, components, or devices.

multi-mode fiber	A fiber optic cable with a diameter large enough (50 microns or more) to allow multiple streams of light to travel different paths from the transmitter to the receiver. This transmission mode enables bidirectional transmissions.
Network Storage Controller	See NSC .
NONCRITICAL Condition	A drive enclosure EMU condition report that occurs when one or more elements inside the enclosure have failed or are operating outside of their specifications. The failure does not affect continued normal operation of the enclosure. All devices in the enclosure continue to operate according to their specifications. The ability of the devices to operate correctly may be reduced if additional failures occur. UNRECOVERABLE and CRITICAL errors have precedence over this condition. This condition has precedence over INFORMATION condition. <i>Early correction can prevent the loss of data.</i>
node port	A device port that can operate on the arbitrated loop topology.
non-OFC (Open Fibre Control)	A laser transceiver whose lower-intensity output does not require special open Fibre Channel mechanisms for eye protection. The Enterprise storage system transceivers are non-OFC compatible.
NSC	Network Storage Controller. The HSV Controllers used by the Enterprise storage system.
NVRAM	Nonvolatile Random Access Memory. Memory whose contents are not lost when a system is turned Off or if there is a power failure. This is achieved through the use of UPS batteries or implementation technology such as flash memory. NVRAM is commonly used to store important configuration parameters.
occupancy alarm level	A percentage of the total disk group capacity in blocks. When the number of blocks in the disk group that contain user data reaches this level, an event code is generated. The alarm level is specified by the user.
OCP	Operator Control Panel. The element that displays the controller's status using indicators and an LCD. Information selection and data entry is controlled by the OCP push buttons.
online/nearonline	An online drive is a normal, high-performance drive, while a near-online drive is a lower-performance drive.
operator control panel	See OCP .
OpenView Storage Management Server	A centralized, appliance-based monitoring and management interface that supports multiple applications, operating systems, hardware platforms, storage systems, tape libraries and SAN-related interconnect devices. It is included and resides on the SANWorks Management Server, a single aggregation point for data management.
param	That portion of the HSV controller termination code display that defines: <ul style="list-style-type: none"> • The 2-character parameter identifier that is a decimal number in the 0 through 30 range. • The 8-character parameter code that is a hexadecimal number. See also IDX and TC .
password	A security interlock where the purpose is to allow: <ul style="list-style-type: none"> • A management agent to control only certain storage systems • Only certain management agents to control a storage system
PDM	Power Distribution Module. A thermal circuit breaker-equipped power strip that distributes power from a PDU to Enterprise Storage System elements.

PDU	Power Distribution Unit. The rack device that distributes conditioned AC or DC power within a rack.
petabyte	A unit of storage capacity that is the equivalent of 2^{50} , 1,125,899,906,842,624 bytes or 1,024 terabytes.
physical disk	A disk drive mounted in a drive enclosure that communicates with a controller pair through the device-side Fibre Channel loops. A physical disk is hardware with embedded software, as opposed to a virtual disk, which is constructed by the controllers. Only the controllers can communicate directly with the physical disks. The physical disks, in aggregate, are called the array and constitute the storage pool from which the controllers create virtual disks.
physical disk array	See array .
port	A Fibre Channel connector on a Fibre Channel device.
port_name	A 64-bit unique identifier assigned to each Fibre Channel port. The port_name is communicated during the login and port discovery processes.
port-wine colored	A convention of applying the color of port wine to a CRU tab, lever, or handle to identify the unit as hot-pluggable.
power distribution module	See PDM .
power distribution unit	See PDU .
power supply	An element that develops DC voltages for operating the storage system elements from either an AC or DC source.
preferred address	An AL_PA which a node port attempts to acquire during loop initialization.
preferred path	A preference for which controller of the controller pair manages the virtual disk. This preference is set by the user when creating the virtual disk. A host can change the preferred path of a virtual disk at any time. The primary purpose of preferring a path is load balancing.
protocol	The conventions or rules for the format and timing of messages sent and received.
push button	A that is engaged or disengaged when it is pressed.
quiesce	The act of rendering bus activity inactive or dormant. For example, “quiesce the SCSI bus operations during a device warm-swap.”
rack	A floorstanding structure primarily designed for, and capable of, holding and supporting storage system equipment. All racks provide for the mounting of panels per Electronic Industries Alliance (EIA) <i>Standard RS310C</i> .
rack-mounting unit	A measurement for rack heights based upon a repeating hole pattern. It is expressed as “U” spacing or panel heights. Repeating hole patterns are spaced every 1.75 inches (44.45 mm) and based on EIA’s <i>Standard RS310C</i> . For example, a 3U unit is 5.25inches (133.35 mm) high, and a 4U unit is 7.0inches (177.79 mm) high.
read caching	A cache method used to decrease subsystem response times to a read request by allowing the controller to satisfy the request from the cache memory rather than from the disk drives. Reading data from cache memory is faster than reading data from a disk. The read cache is specified as either On or Off for each virtual disk. The default state is on.

read ahead caching	A cache management method used to decrease the subsystem response time to a read request by allowing the controller to satisfy the request from the cache memory rather than from the disk drives.
reconstruction	The process of regenerating the contents of a failed member data. The reconstruction process writes the data to a spare set disk and incorporates the spare set disk into the mirrorset, striped mirrorset or RAID set from which the failed member came.
redundancy	<ol style="list-style-type: none"> 1. Element Redundancy—The degree to which logical or physical elements are protected by having another element that can take over in case of failure. For example, each loop of a device-side loop pair normally works independently but can take over for the other in case of failure. 2. Data Redundancy—The level to which user data is protected. Redundancy is directly proportional to cost in terms of storage usage; the greater the level of data protection, the more storage space is required.
redundant power configuration	<p>A capability of the Enterprise storage system racks and enclosures to allow continuous system operation by preventing single points of power failure.</p> <ul style="list-style-type: none"> • For a rack, two AC power sources and two power conditioning units distribute primary and redundant AC power to enclosure power supplies. • For a controller or drive enclosure, two power supplies ensure that the DC power is available even when there is a failure of one supply, one AC source, or one power conditioning unit. Implementing the redundant power configuration provides protection against the loss or corruption of data.
reporting group	An Enterprise Storage System controller pair and the associated disk drive enclosures. The Enterprise Storage System controller assigns a unique decimal reporting group number to each EMU on its loops. Each EMU collects disk drive environmental information from its own sub-enclosure and broadcasts the data over the enclosure address bus to all members of the reporting group. Information from enclosures in other reporting groups is ignored.
room temperature	See ambient temperature
SCSI	<ol style="list-style-type: none"> 1. Small Computer System Interface. An American National Standards Institute (ANSI) interface which defines the physical and electrical parameters of a parallel I/O bus used to connect computers and a maximum of 16 bus elements. 2. The communication protocol used between a controller pair and the hosts. Specifically, the protocol is Fibre Channel drive enclosure or SCSI on Fibre Channel. SCSI is the higher command-level protocol and Fibre Channel is the low-level transmission protocol. The controllers have full support for SCSI-2; additionally, they support some elements of SCSI-3.
SCSI-3	The ANSI standard that defines the operation and function of Fibre Channel systems.
SCSI-3 Enclosure Services	See SES .
selective presentation	The process whereby a controller presents a virtual disk only to the host computer which is authorized access.
serial transmission	A method of transmission in which each bit of information is sent sequentially on a single channel rather than simultaneously as in parallel transmission.
SES	SCSI-3 Enclosures Services. Those services that establish the mechanical environment, electrical environment, and external indicators and controls for the proper operation and maintenance of devices within an enclosure.

small computer system interface	See SCSI .
Snapclone	A virtual disk that can be manipulated while the data is being copied. Only an Active member of a virtual disk family can be snapcloned. The Snapclone, like a snapshot, reflects the contents of the source virtual disk at a particular point in time. Unlike the snapshot, the Snapclone is an actual clone of the source virtual disk and immediately becomes an independent Active member of its own virtual disk family.
snapshot	A temporary virtual disk (Vdisk) that reflects the contents of another virtual disk at a particular point in time. A snapshot operation is only done on an active virtual disk. Up to seven snapshots of an active virtual disk can exist at any point. The active disk and its snapshot constitute a virtual family. See also active virtual disk , virtual disk copy , and virtual disk family .
SSN	Storage System Name. An HP Command View EVA-assigned, unique 20-character name that identifies a specific storage system.
storage carrier	See carrier .
storage pool	The aggregated blocks of available storage in the total physical disk array.
storage system	The controllers, storage devices, enclosures, cables, and power supplies and their software.
Storage System Name	See SSN .
	An electro-mechanical device that initiates an action or completes a circuit.
TB	Terabyte. A term defining either: <ul style="list-style-type: none"> • A data transfer rate. • A measure of either storage or memory capacity of 1,099,511,162,776 (2⁴⁰) bytes. See also TBps .
TBps	Terabytes per second. A data transfer rate of 1,000,000,000,000 (10 ¹²) bytes per second.
TC	Termination Code. An Enterprise Storage System controller 8-character hexadecimal display that defines a problem causing controller operations to halt. See also IDX and param .
Termination Code	See TC .
termination event	Occurrences that cause the storage system to cease operation.
terminator	Interconnected elements that form the ends of the transmission lines in the enclosure address bus.
topology	An interconnection scheme that allows multiple Fibre Channel ports to communicate. Point-to-point, arbitrated loop, and ed fabric are all Fibre Channel topologies.
transceiver	The device that converts electrical signals to optical signals at the point where the fiber cables connect to the FC elements such as hubs, controllers, or adapters.
uninitialized system	A state in which the storage system is not ready for use. See also initialization .
UNRECOVERABLE Condition	A drive enclosure EMU condition report that occurs when one or more elements inside the enclosure have <i>failed</i> and have disabled the enclosure. The enclosure

may be incapable of recovering or bypassing the failure and will require repairs to correct the condition.

This is the highest level condition and has precedence over all other errors and requires *immediate corrective action*.

unwritten cached data	Also called unflushed data. See also dirty data .
UPS	Uninterruptible Power Supply. A battery-operated power supply guaranteed to provide power to an electrical device in the event of an unexpected interruption to the primary power supply. Uninterruptible power supplies are usually rated by the amount of voltage supplied and the length of time the voltage is supplied.
Vdisk	Virtual Disk. A simulated disk drive created by the controllers as storage for one or more hosts. The virtual disk characteristics, chosen by the storage administrator, provide a specific combination of capacity, availability, performance, and accessibility. A controller pair simulates the characteristics of the virtual disk by deploying the disk group from which the virtual disk was created. The host computer sees the virtual disk as "real," with the characteristics of an identical physical disk. See also active virtual disk , virtual disk copy , virtual disk family , and virtual disk snapshot .
virtual disk	See Vdisk .
virtual disk copy	A clone or exact replica of another virtual disk at a particular point in time. Only an active virtual disk can be copied. A copy immediately becomes the active virtual disk of its own virtual disk family. See also active virtual disk , virtual disk family , and virtual disk snapshot
virtual disk family	A virtual disk and its snapshot, if a snapshot exists, constitute a family. The original virtual disk is called the active disk. When you first create a virtual disk family, the only member is the active disk. See also active virtual disk , virtual disk copy , and virtual disk snapshot .
virtual disk snapshot	See snapshot .
Vraid0	A virtualization technique that provides no data protection. Data host is broken down into chunks and distributed on the disks comprising the disk group from which the virtual disk was created. Reading and writing to a Vraid0 virtual disk is very fast and makes the fullest use of the available storage, but there is no data protection (redundancy) unless there is parity.
Vraid1	A virtualization technique that provides the highest level of data protection. All data blocks are mirrored or written twice on separate physical disks. For read requests, the block can be read from either disk, which can increase performance. Mirroring takes the most storage space because twice the storage capacity must be allocated for a given amount of data.
Vraid5	A virtualization technique that uses parity striping to provide moderate data protection. Parity is a data protection mechanism for a striped virtual disk. A striped virtual disk is one where the data to and from the host is broken down into chunks and distributed on the physical disks comprising the disk group in which the virtual disk was created. If the striped virtual disk has parity, another chunk (a parity chunk) is calculated from the set of data chunks and written to the physical disks. If one of the data chunks becomes corrupted, the data can be reconstructed from the parity chunk and the remaining data chunks.
World Wide Name	See WWN .

**write back
caching**

A controller process that notifies the host that the write operation is complete when the data is written to the cache. This occurs before transferring the data to the disk. Write back caching improves response time since the write operation completes as soon as the data reaches the cache. As soon as possible after caching the data, the controller then writes the data to the disk drives.

write caching

A process when the host sends a write request to the controller, and the controller places the data in the controller cache module. As soon as possible, the controller transfers the data to the physical disk drives.

WWN

World Wide Name. A unique Fibre Channel identifier consisting of a 16-character hexadecimal number. A WWN is required for each Fibre Channel communication port.

Index

Symbols

- +5.1 VDC, 56
- 4 Gb controller identification, 23

A

- AC input missing, 131
- AC power
 - distributing, 85
 - frequency, 56
 - voltage, 56
- air flow
 - affecting temperature, 57
 - adjusting automatically, 57
- alarm code cycles, 61
- alphanumeric display
 - controlling, 60
 - description, 59, 60
- API versions, 79
- ASCII, error codes definitions, 149
- asynchronous disk swap, 20
- audible alarm
 - unmuting, 63
 - disabling, 63
 - enabling, 62
 - muting, 63
 - selecting display group, 60
 - sound patterns, 61
- automatically correcting errors, 58

B

- backplane
 - NONCRITICAL conditions, 143, 143, 143
 - NVRAM conditions, 137, 143
- bays
 - locating, 49
 - numbering, 49
- benefits, 17
- bidirectional operation, 51
- blowers
 - cooling enclosures, 57
 - UNRECOVERABLE conditions, 133
 - CRITICAL conditions, 132
 - failure, 133
 - missing, 133, 133
 - monitored functions, 59
 - NONCRITICAL conditions, 132, 133
 - speed, 132
 - status indicators, 57
 - UNRECOVERABLE conditions, 133
- browser interface, 20

C

- cables
 - FCC compliance statement, 114
- cabling controller, 85
- CAC, 147, 149
- cache battery assembly indicator, 76
- CAUTIONs
 - initializing the system, 81
- CDRH, compliance regulations, 115
- Center for Devices and Radiological Health
 - See CDRH
- certification product labels, 121
- changing passwords, 81
- checksum, 32
- Class A equipment, Canadian compliance statement, 115
- Class B equipment, Canadian compliance statement, 115
- cleaning fiber optic connectors, 47
- clearing passwords, 82
- clustering, 17
- code flag, 147
- Command View EVA
 - defined, 20, 20
 - location of, 25
- Command View GUI
 - displaying events, 147
 - displaying termination events, 147
- commercial environments, use in, 17
- components, storage system, 20
- condition reporting
 - backplane, 143
 - current sensors, 141
 - drives, 128
 - element types, 128
 - EMU, 136
 - hosts, 145
 - I/O modules, 143
 - power supplies, 130
 - transceivers, 140
 - voltage sensor, 141
- condition reporting
 - temperature, 133
- conditions, EMU detection of, 58
- configuration
 - physical layout, 21
- connectors
 - power IEC 309 receptacle, 86
 - power NEMA L6-30R, 86
 - protecting, 46

- controller
 - cabling, 85
 - connectors, 85
 - defined, 21, 23
 - initial setup, 31
 - status indicators, 76
- controls, 57
- conventions
 - text symbols, 14
- cooling
 - enclosures, 57
 - blowers, 55
 - power supplies, 56
- Corrective Action Code
 - See CAC
- Corrective Action Codes
 - See CAC
- country-specific certifications, 121
- coupled crash control codes, 149
- CRITICAL conditions
 - I/O modules communication, 144
 - audible alarm, 62
 - blowers speed, 132
 - drive link rate, 128, 130, 130
 - drives configuration, 128
 - EMU internal clock, 136
 - high current, 142
 - high temperature, 134
 - high voltage, 142
 - I/O modules unsupported, 144
 - low temperature, 135
 - low voltage, 142
 - transceivers, 140, 141
- current sensors, 141

D

- data center, use in, 17
- DC power
 - +5.1 VDC, 56
- detail view, 148
- detail view menu, 149
- diagnostic information, 56
- disabling the audible alarm, 63
- disk drives
 - defined, 53
 - hot swapping, 20
 - power usage, 56
 - reporting status, 54
- display groups
 - error code, Er, 60
 - audible alarm, Au, 60
 - enclosure number, En, 60
 - loop ID, Li, 60
 - reporting group, rG, 60
- displaying errors, 58
- displays
 - audible alarm, 59, 61
 - EMU status, 59
 - enclosure status, 59

- document
 - prerequisites, 13
- drive enclosures
 - defined, 21
 - front view, 49
- drives
 - detecting configuration error, 128
 - detecting drive link error, 130, 130
 - detecting link rate error, 128
 - missing, 129
 - monitoring functions, 59
 - reporting conditions, 128
- dump/restart control codes, 149
- dust covers, using, 47
- dynamic capacity expansion, 20

E

- EIP, 148, 149
- element condition reporting;, 128
- EMU
 - controls, 57
 - alphanumeric display, 59
 - conditions, 136
 - CRITICAL conditions, 136
 - displaying status, 57
 - INFORMATION conditions, 137, 139
 - locating, 22
 - NONCRITICAL conditions, 137, 137, 138, 138
 - resetting, 136
 - status indicators, 59
 - UNRECOVERABLE conditions, 136, 138, 139
- EMU indicator displays, 60
- EMU monitoring functions , 59
- En description, 64
- enabling the audible alarm, 62
- enclosure address bus
 - defined, 64
 - detecting errors with, 138
- enclosure certification label, 122
- enclosure functions, 59
- enclosure number description, 64
- enclosure number display group, 60
- Enclosure Services Interface
 - See ESI
- Enclosure Services Interface
 - See ESI
- Enclosure Services Processor
 - See ESP
- enclosures
 - cooling, 57
 - adjusting temperature, 57
 - bays, 49
 - managing air flow, 57
 - sensing temperature, 56
- enclosures, physical specifications, 122
- Enterprise rack
 - physical layout, 21

- environmental specifications
 - drive enclosure, 122
- error code
 - selecting display group, 60
- error codes, defined, 149
- error messages, 58
- errors
 - displaying, 58
 - correcting automatically, 58
- ESI, 18, 58
- ESP, 58
- event code, defined, 149
- event GUI display, 147
- Event Information Packet
 - See EIP
- Event Information Packets
 - See EIP
- event number, 147

F

- failure, 143
- fan redundancy, 22
- FATA drives, using, 35
- fault management
 - details, 148
 - display, 77
 - displays, 148
- fault tolerance, 20
- FC loops, 25, 51
- FCC
 - Class A Equipment, compliance notice, 113
 - Class B Equipment, compliance notice, 114
 - Declaration of Conformity, 114
 - modifications, 114
- FCC Class A certification, 113
- features
 - defined, 17
 - XCS, 20
- Federal Communications Commission (FCC)
 - notice, 113
- fiber optics
 - cleaning cable connectors, 47
 - protecting cable connectors, 46
- Fibre Channel Drive Enclosure
 - defined, 21, 22
 - disk capacity, 22
- Fibre Channel drive enclosures, 57
- Fibre Channel Loop Switches, 71
 - defined, 21, 22, 70
 - reading indicators, 72
 - testing, 72
- Fibre Channel loop switches
 - connecting to, 21
- file name, error code definitions, 149
- firmware version display, 79
- functions monitoring, 59

H

- hardware components, 21
- harmonics conformance
 - Japan, 121
- high availability
 - HSV Controllers, 75
- high current conditions, 142, 142
- high temperature conditions, 134, 134, 135
- high voltage conditions, 142, 142
- host bus adapters, 30
- hot swap, 20
- HP
 - Subscriber's choice web site, 15
- HSV controller
 - OCP
 - shutting down the controller, 80
 - shutdown, 80
- HSV Controllers
 - defined, 21, 23
 - initial setup, 31
- HSV controllers
 - identifying 4 Gb, 23

I

- I/O modules
 - bidirectional, 51
 - CRITICAL conditions, 144
 - monitored functions, 59
 - NONCRITICAL conditions, 144, 144, 145
- I/O modules
 - CRITICAL conditions, 144
 - element numbering, 144
- IDX code display, 148
- indicators
 - battery status, 76
 - EMU displays, 60
 - push buttons, 77
 - pushbuttons, 61
- INFORMATION conditions
 - audible alarm, 62
 - drive missing, 129
 - EMU, 137, 139
- INITIALIZE LCD, 80
- initializing the system
 - defined, 80
- internal clock, 136
- iSCSI configurations, 29

L

- labels
 - enclosure certification, 122
 - product certification, 121
- laser device
 - regulatory compliance notice, 114
- lasers
 - radiation, warning, 114
- last fault information, 148

Last Termination Event Array

See LTEA

LCD

default display, 77

Li

display group, 60

Loop ID

display group, 60

loop switches, 21

defined, 21

low temperature

CRITICAL conditions, 135

NONCRITICAL conditions, 135

low voltage

CRITICAL conditions, 142

NONCRITICAL conditions, 142

LTEA, 148

LUN numbers, 30

M

Management Server, 33

Management Server, Command View EVA, 25

missing

AC input, 131

power supplies, 131, 131

Modular Array family, 17

monitored functions

blowers, 59

I/O module, 59

power supply, 59

multipathing, 17

N

non-standard rack, specifications, 151

NONCRITICAL conditions

audible alarm, 62

blowers

missing, 133

EMU

NVRAM write failure, 137

enclosure address, 138

backplane, 143

NVRAM conditions, 143

blowers

speed, 132

EMU

cannot read NVRAM data, 138

enclosure address, 138

NVRAM invalid read data, 137

high current, 142

high temperature, 134

high voltage, 142

I/O modules, 144

low temperature, 135

low voltage, 142

NVRAM, 137

NVRAM read, 143

NVRAM write failure, 137

power supplies, 131

NONCRITICAL conditions

NVRAM read failure, 143

not installed

power supplies, 131

NVRAM read failure, 145

NVRAM write failure, 137

O

OCP

fault management displays, 148

using, 31

OCP

pushbutton icons, 82

online help system, 20

OpenView Storage Management Server, 20,

33

P

page-level help, 20

parameter code, 148

parameter code number, 148

password

clearing, 82

entering, 81

changing, 81, 82

clearing, 81

entering, 32

removing, 81

PDU, 85

physical configuration, 21

physical specifications

enclosures, 122

PIC, 79

- port indicators, [70, 71, 72](#)
- POST, [72](#)
- power connectors
 - IEC 309 receptacle, [86](#)
 - NEMA L6-30R, [86](#)
- POWER OFF LCD, [80](#)
- power specifications
 - drive enclosure, [123](#)
- power supplies, [56](#)
 - sensing temperature, [56](#)
 - AC frequency, [56](#)
 - AC input missing, [131](#)
 - AC voltage, [56](#)
 - cooling, [56](#)
 - DC outputs, [56](#)
 - missing, [131, 131](#)
 - NONCRITICAL conditions, [131](#)
 - not installed, [131](#)
 - overload, [56](#)
 - protection, [56](#)
 - status indicators, [57](#)
 - thermal protection, [56](#)
 - UNRECOVERABLE conditions, [137, 139](#)
- power supplies
 - monitored functions, [59](#)
- power supply redundancy, [22](#)
- Power-On Self Test
 - See POST
- powering off the system
 - defined, [80](#)
- prerequisites, [13](#)
- product certification, [121](#)
- protecting
 - power supplies, [56](#)
- protecting fiber optic connectors
 - cleaning supplies, [47](#)
 - dust covers, [47](#)
 - how to clean, [47](#)
- push buttons
 - indicators, [77](#)
 - definition, [77](#)
 - navigating with, [77](#)
- pushbuttons
 - EMU, [61](#)
- pushbuttons
 - icons, [82](#)

R

- rack
 - defined, [23](#)
 - non-standard specifications, [151](#)
 - physical layout, [21](#)
- rack configurations, [85](#)

- regulatory compliance notices
 - cables, [114](#)
 - Class A, [113](#)
 - Class B, [114](#)
 - European Union, [115](#)
 - Japan, [121](#)
 - laser devices, [114](#)
 - modifications, [114](#)
 - Taiwan, [121](#)
 - WEEE recycling notices, [116](#)
- regulatory notices, [113](#)
- resetting EMU, [136](#)
- RESTART LCD, [80](#)
- restarting the system, [80, 81](#)
- restarting the system
 - defined, [80](#)
- rH displays, [70](#)
- rL displays, [70](#)

S

- sensing
 - power supply temperature, [56](#)
- SES compliance, [57](#)
- setting password, [32](#)
- SFP, [73](#)
- short circuit, [56](#)
- shutdown
 - controllers, [80](#)
 - shutdown failure, [139](#)
 - shutdown system, [78](#)
 - shutting down the system, [80](#)
 - restarting, [81](#)
- signals, diagnostic, [56](#)
- slots
 - See enclosures, bays
- Software Component ID Codes
 - See SWCID
- Software Identification Code
 - See SWCID
- software version display, [79, 79](#)
- specifications
 - physical, [122](#)
 - power, [123](#)
- speed conditions, blower, [132, 132, 133](#)
- status indicators
 - power supplies, [57](#)
 - status, disk drives, [54](#)
- storage system
 - restarting, [81](#)
 - initializing, [81](#)
 - shutting down, [80](#)
- storage system components, [20](#)
- storage system menu tree
 - fault management, [77](#)
 - system information, [77](#)
- Storage System Name, [77](#)
- storage system racks, defined;, [23](#)
- Subscriber's choice, HP, [15](#)
- SWCID, [147, 148, 149](#)

- symbols in text, 14
- system information
 - firmware version, 79
 - software version, 79
 - versions, 79
- system information display, 77
- system menu tree
 - shut down system, 78
 - system password, 78
- system password, 78
- system rack configurations, 85

T

- TC, 149
- TC display, 148
- TC error code, 148
- temperature
 - condition reports, 133
 - effect of air flow, 57
 - sensing, 56
- Termination Code
 - See TC
- termination event GUI display, 147
- text symbols, 14
- transceivers
 - CRITICAL conditions, 140, 140, 141
 - monitored functions, 59
- turning off power, 80

U

- Uninitializing, 81
- initializing the system, 81
- universal disk drives, 53
- UNRECOVERABLE conditions
 - blowers
 - no blowers installed, 133
 - audible alarm, 62
 - backplane NVRAM, 137
 - blowers
 - failure, 133
 - EMU
 - load failure, 138
 - communications interrupted, 136
 - hardware failure, 139
 - high temperature, 135
 - power supplies
 - missing, 131
 - shutdown, 137
 - missing, 131
 - shutdown failure, 139
 - shutdown, 137
- UPS, selecting, 155
- user interface, 20, 20

- using the OCP, 31

V

- verifying operation, 57
- version information
 - displaying, 79
 - software, 79
 - Controller, 79
 - firmware, 79
 - OCP, 79
 - software, 79
 - XCS, 79
- version information: firmware, 79
- virtual RAID, 17
 - See also Vraid
- virtualization, 18
- voltage sensors, 141
- Vraid, 18, 20

W

- warnings
 - lasers, radiation, 114
- web sites
 - HP Subscriber's choice, 15
- WEEE recycling notices, 116
- WWN labels, 31
- WWN, backplane, 143
- WWN, blank, 143

X

- XCS
 - defined, 20
 - features, 20
- XCS version, 79