

HP Photosmart D7100 series



使用者指南

User Guide



www.hp.com/support

021 67 22 80	الجزائر
Argentina (Buenos Aires)	54-11-4708-1600
Argentina	0-800-555-5000
Australia	1300 721 147
Australia (out-of-warranty)	1902 910 910
Österreich	www.hp.com/support
17212049	البحرين
België	www.hp.com/support
Belgique	www.hp.com/support
Brasil (Sao Paulo)	55-11-4004-7751
Brasil	0-800-709-7751
Canada	1-800-474-6836 (1-800 hp invent)
Central America & The Caribbean	www.hp.com/support
Chile	800-360-999
中国	10-68687980 8008103888
Colombia (Bogotá)	571-606-9191
Colombia	01-8000-51-4746-8368
Costa Rica	0-800-011-1046
Česká republika	810 222 222
Danmark	www.hp.com/support
Ecuador (Andinatel)	1-999-119 800-711-2884
Ecuador (Pacifitel)	1-800-225-528 800-711-2884
(02) 6910602	مصر
El Salvador	800-6160
España	www.hp.com/support
France	www.hp.com/support
Deutschland	www.hp.com/support
Ελλάδα (από το εξωτερικό)	+ 30 210 6073603
Ελλάδα (εντός Ελλάδας)	801 11 75400
Ελλάδα (από Κύπρο)	800 9 2654
Guatemala	1-800-711-2884
香港特別行政區	(852) 2802 4098
Magyarország	06 40 200 629
India	1-800-425-7737 91-80-28526900
Indonesia	+62 (21) 350 3408
+971 4 224 9189	العراق
+971 4 224 9189	الكويت
+971 4 224 9189	لبنان
+971 4 224 9189	قطر
+971 4 224 9189	اليمن
Ireland	www.hp.com/support
1-700-503-048	ישראל
Italia	www.hp.com/support
Jamaica	1-800-711-2884

日本	0570-000-511
日本 (携帯電話の場合)	03-3335-9800
0800 222 47	الأردن
한국	1588-3003
Luxembourg	www.hp.com/support
Malaysia	1800 88 8588
Mauritius	(262) 262 210 404
México (Ciudad de México)	55-5258-9922
México	01-800-472-68368
081 005 010	المغرب
Nederland	www.hp.com/support
New Zealand	0800 441 147
Nigeria	(01) 271 2320
Norge	www.hp.com/support
24791773	عمان
Panamá	1-800-711-2884
Paraguay	009 800 54 1 0006
Perú	0-800-10111
Philippines	(2) 867 355 1 1800 144 10094
Polska	22 5666 000
Portugal	www.hp.com/support
Puerto Rico	1-877-232-0589
República Dominicana	1-800-711-2884
Reunion	0820 890 323
România	0801 033 390
Россия (Москва)	095 777 3284
Россия (Санкт-Петербург)	812 332 4240
800 897 1415	السعودية
Singapore	6272 5300
Slovensko	0850 111 256
South Africa (international)	+ 27 11 2589301
South Africa (RSA)	0860 104 771
Rest of West Africa	+ 351 213 17 63 80
Suomi	www.hp.com/support
Sverige	www.hp.com/support
Switzerland	www.hp.com/support
臺灣	(02) 8722 8000
ไทย	+66 (2) 353 9000
071 891 391	تونس
Trinidad & Tobago	1-800-711-2884
Türkiye	+90 (212)291 38 65
Україна	(044) 230-51-06
600 54 47 47	الإمارات العربية المتحدة
United Kingdom	www.hp.com/support
United States	1-(800)-474-6836 (1-800 hp invent)
Uruguay	0004-054-177
Venezuela (Caracas)	58-212-278-8666
Venezuela	0-800-474-68368
Việt Nam	+84 (8) 823 4530

HP Photosmart D7100 series 使用者指南

繁體中文



著作權和商標

© 2006 Hewlett-Packard Development Company, L.P.

本文件中包含的資訊如有變更，恕不另行通知。除非著作權法允許，否則未事先取得書面許可，不得進行重製、改編或翻譯。

Hewlett-Packard 公司通告

本文件包含的資訊如有更改，恕不另行通知。

版權所有，翻印必究。除版權法允許之外，未經 Hewlett-Packard 事先書面許可，不得對本手冊進行複製、改編或翻譯。

HP 產品與服務的唯一擔保已在這些產品與服務隨附的書面保固聲明中闡明。此處的任何資訊將不會構成額外擔保的制定。HP 將不會對本文包含的技術或編輯錯誤或者疏忽負責。

商標

HP、HP 標誌與 Photosmart 為 Hewlett-Packard Development Company, L.P. 之財產。

Secure Digital 標誌為 SD Association 的商標。

Microsoft 與 Windows 為 Microsoft Corporation 的註冊商標。

CompactFlash、CF 與 CF 標誌為 CompactFlash Association (CFA) 的商標。

Memory Stick、Memory Stick Duo、Memory Stick PRO 與 Memory Stick PRO Duo 為 Sony Corporation 的商標或註冊商標。

MultiMediaCard 為德國 Infineon Technologies AG 的商標，並授權給 MMCA (MultiMediaCard Association)。

Microdrive 為 Hitachi Global Storage Technologies 的商標。

xD-Picture Card 是 Fuji Photo Film Co., Ltd.、Toshiba Corporation 與 Olympus Optical Co., Ltd. 的商標。

Mac、Mac 標誌與 Macintosh 為 Apple Computer, Inc. 的註冊商標。

iPod 為 Apple Computer, Inc. 的商標。

Bluetooth 商標屬於其所有者，Hewlett-Packard 公司已獲得使用該商標的授權。

PictBridge 與 PictBridge 標誌為 Camera & Imaging Products Association (CIPA) 的商標。

其他品牌與其產品為其各自持有者之商標或註冊商標。

法規機型識別號碼

為了法規識別的目的，本產品具有一個法規機型識別號碼。本產品的法規機型

識別號碼為 VCVRA-0603。請勿將此法規號碼與行銷名稱 (HP Photosmart D7100 series 等) 或產品編號 (Q7046A 等) 混淆。

能源消耗 - Energy Star®

Hewlett-Packard 致力在符合環保的原則下，提供高品質的產品。如需 HP 環保產品管理方案的相關資訊，請參閱螢幕說明。

目錄

1 歡迎	7
特殊功能	7
存取螢幕 HP Photosmart 說明	7
印表機零件	8
選用配件	11
印表機功能選項	11
檢視與列印	12
儲存檔案	12
共享	12
設定	12
2 準備列印	15
放入紙張	15
選擇適用的紙張	15
放入紙張訣竅	15
放入主紙匣	15
放入相片匣	16
插入墨匣	17
購買替換墨匣	17
墨匣訣竅	18
墨匣保固資訊	18
插入或更換墨匣	19
插入記憶卡	20
支援的檔案格式	20
插入記憶卡	21
記憶卡類型	21
取出記憶卡	22
3 列印相片時不連接電腦	23
列印相片	23
從記憶卡列印相片	23
列印一張或多張相片	23
列印記憶卡上的所有相片	23
列印記憶卡中相機選擇的相片	24
使用精靈進行列印	24
從視訊片段列印相片	24
列印相片索引頁	25
停止列印	25
從數位相機列印相片	25
配備 Bluetooth 無線技術的數位相機	25
配備 PictBridge 技術的數位相機	26

	從 iPod 列印相片.....	26
	相片版面.....	27
	提高相片品質.....	28
	調整亮度不足的相片.....	28
	消除相片中的紅眼.....	29
	調整品質不佳的視訊片段.....	29
	使用創意.....	29
	增加色彩效果.....	29
	在相片上增加日期和時間.....	29
	變更列印品質.....	30
	裁剪相片.....	30
	列印全景相片.....	30
4	連接	33
	連接到其他裝置.....	33
	將相片儲存到電腦.....	35
	透過「HP Photosmart 共享」連接.....	35
5	從電腦列印	37
	使用印表機軟體中的創意選項.....	37
	HP Photosmart Premier (Windows 使用者).....	37
	HP Photosmart Essential (Windows 使用者).....	37
	HP Photosmart Studio (Macintosh 使用者).....	38
	HP Photosmart 共享.....	38
	設定列印偏好值.....	38
	開啓電子版說明.....	39
	HP Real Life 技術功能.....	39
6	愛護與維護	41
	清潔及維護印表機.....	41
	清潔印表機外部.....	41
	校正印表機.....	41
	列印樣本頁.....	41
	自動清潔列印頭.....	42
	手動清潔墨匣的接點.....	42
	列印自我測試報告.....	43
	更新軟體.....	44
	儲存及運送印表機和墨匣.....	45
	儲存及運送印表機.....	45
	儲存及運送墨匣.....	45
	維護相紙的品質.....	45
7	疑難排解	47
	印表機硬體問題.....	47
	列印問題.....	48
	錯誤訊息.....	51
	紙張錯誤.....	52
	墨匣錯誤.....	53

目錄

記憶卡錯誤.....	56
電腦和連線列印錯誤.....	59
8 HP 支援中心.....	61
支援程序.....	61
致電 HP 支援中心.....	61
電話支援期限.....	61
致電.....	61
電話支援期限過後.....	62
A 規格.....	63
系統需求.....	63
印表機規格.....	63
B HP 保固.....	67
索引.....	69

1 歡迎

非常感謝您購買 HP Photosmart D7100 series 印表機！使用此新型相片印表機，不論是否使用電腦，您都可以列印精美的相片、儲存相片到電腦以及製作簡易有趣的專案。

本手冊主要說明如何在不連接電腦的情況下列印。若要了解如何從電腦列印，請安裝印表機軟體並檢視電子說明。如需關於利用電腦使用印表機的概述，請參閱[從電腦列印](#)。如需安裝軟體的詳細資訊，請參閱「快速入門」指南。

家庭使用者可了解如何：

- 從印表機或電腦列印無邊框相片
- 選擇相片版面
- 將彩色相片轉換成黑白相片，或套用色彩效果，如：褐色或古董色

印表機隨附以下說明文件：

- **快速入門指南：**「快速入門指南」說明如何安裝印表機和印表機軟體，以及如何開始列印您的第一張相片。
- **使用者指南：**「使用者指南」就是您正在閱讀的這本書。描述印表機的基本功能，說明如何在不連接電腦的情況下使用印表機，亦包含硬體疑難排解資訊。
- **螢幕說明：**螢幕「HP Photosmart 說明」描述如何利用電腦使用本印表機，並包含軟體疑難排解資訊。

特殊功能

新功能與材質使製作高品質相片變得更加容易：

- 在使用新款 HP 進階相紙 (在某些國家/地區也稱為 HP 相紙) 時，印表機中的特殊感應器會偵測到相紙背面的標記，並且會自動選取最佳的列印設定。如需此新款相紙的詳細資訊，請參閱[選擇適用的紙張](#)。
- HP Real Life 技術讓您可輕易獲得品質更佳的相片。自動消除紅眼和用來增強陰影中細節效果的適應照明僅是其中一些技術。您可以從印表機軟體中獲取許多編輯和增強選項。若要從控制台存取這些功能，請參閱[提高相片品質](#)。若要了解如何在軟體中找到這些功能，請參閱 [HP Real Life 技術功能](#)。

存取螢幕 HP Photosmart 說明

在電腦上安裝好 HP Photosmart 軟體後，您便可以檢視螢幕 HP Photosmart 說明：

- **Windows PC：**從「開始」功能選項，選取「程式集」(在 Windows XP 中，則選取「所有程式」) > 「HP」> 「HP Photosmart D7100 series」> 「Photosmart 說明」。
- **Macintosh：**在 Finder「輔助說明」選單中，選擇「Mac 輔助說明」。在輔助說明檢視器「程式庫」選單中，選擇「HP PhotosmartMac Help」(HP Photosmart Mac 輔助說明)。

印表機零件

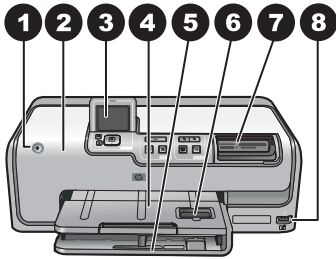

印表機正面

- | | |
|---|--|
| 1 | 開啓 ：按此按鈕可以開啓印表機電源。 |
| 2 | 頂蓋 ：提起此蓋可以拿放墨匣以及清除卡紙。若要提起此蓋，請抓住 HP 標誌下面的頂蓋並向上拉起。 |
| 3 | 印表機螢幕 ：使用此螢幕可以檢視相片、功能選項及訊息。 |
| 4 | 出紙匣 ：此紙匣用於接住印好的紙張。提起此匣可使用相片匣。 |
| 5 | 主紙匣 ：拉出此紙匣可放入紙張、投影片、信封或其他材質，列印面朝下。 |
| 6 | 相片匣 ：提起出紙匣並拉出此匣，可在相片匣中放入最大尺寸至 10 x 15 公分 (4 x 6 英吋) 的小型相紙 (讓列印面朝下) 以進行列印。相紙可以是含標籤或不含標籤。 |
| 7 | 記憶卡插槽 ：在此插入記憶卡。如需支援的記憶卡清單，請參閱 插入記憶卡 。 |
| 8 | 相機連接埠 ：連接 PictBridge™ 數位相機、選購的 HP Bluetooth® 無線印表機轉接器或 iPod。 |

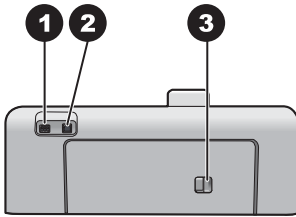

印表機的背面

- | | |
|---|--|
| 1 | 電源線連接 ：使用此連接埠連接印表機附帶的電源線。 |
| 2 | USB 埠 ：使用此連接埠將印表機連接至電腦。 |
| 3 | 後方機門 ：卸下此門可以清除卡紙或安裝選購的 HP 自動雙面列印配件。請參閱 選用配件 。 |

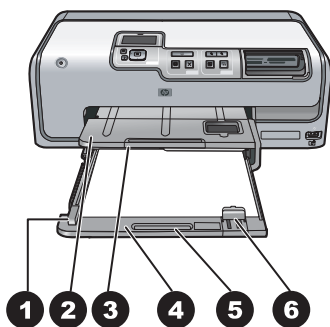

主紙匣與出紙匣

- | | |
|---|---|
| 1 | 紙張寬度導板： 調整此導板使其緊靠主紙匣中紙疊的邊緣。 |
| 2 | 出紙匣： 此紙匣用於接住印好的紙張。提起此匣可以使用相片匣。 |
| 3 | 出紙匣延伸架： 朝您自己的方向拉開，可以延伸出紙匣來接住印出的紙張。 |
| 4 | 主紙匣： 拉出此紙匣可放入一般紙張、投影片、信封或其他材質，列印面朝下。 |
| 5 | 主紙匣把手： 朝您自己的方向拉開，可以延伸主紙匣。 |
| 6 | 紙張長度導板： 調整此導板使其緊靠主紙匣中紙張的末端。 |

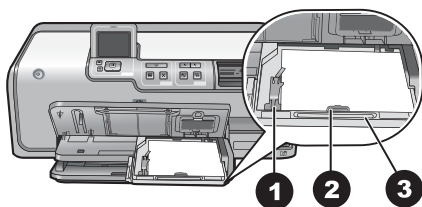

相片匣

- | | |
|---|------------------------------------|
| 1 | 紙張寬度導板： 調整此導板使其緊靠相片匣中紙疊的邊緣。 |
| 2 | 紙張長度導板： 調整此導板使其緊靠相片匣中紙張的末端。 |
| 3 | 相片匣把手： 朝您自己的方向拉開，可以延伸相片匣。 |

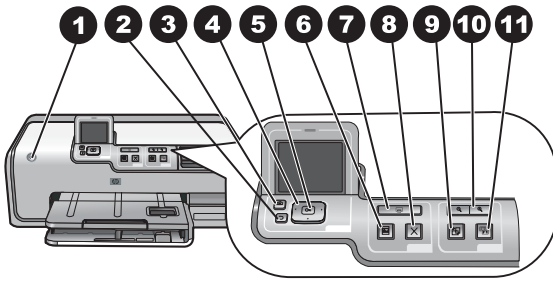

控制台

1	開啓 ：開啓印表機電源或將其置入省電模式。
2	上一頁 ：一次退回一個畫面。
3	首頁 ：按下此按鈕可返回首頁畫面。
4	導覽箭頭 ：調整裁剪方塊、導覽功能選項，以及控制視訊片段的播放。
5	OK ：選取反白強調的項目、功能選項或對話方塊選項，以及在播放期間播放/暫停視訊片段。
6	預覽列印 ：預覽檢視選取的一張或多張相片。
7	列印 ：從插入的記憶卡或從連接到前方相機連接埠的相機，列印選取的相片。
8	取消 ：停止列印工作。
9	旋轉 ：旋轉相片或裁剪方塊。
10	縮放 (+)(-) ：放大或縮小相片或裁剪方塊。您也可以在以正常放大倍數檢視相片時按「縮放 (-)」，一次檢視四張相片。
11	相片修復 ：自動增強相片效果，並將照明、對比、對焦及消除紅眼等功能套用至所有列印的相片。

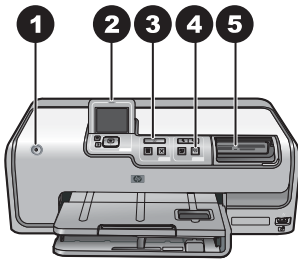

指示燈

1	開啓燈號 ：開啓印表機電源時一直呈藍色亮起，關閉電源時熄滅。
2	注意燈號 ：出現錯誤狀況時會閃爍。如需出錯狀況的指示或詳細資訊，請參閱印表機螢幕。如需詳細資訊，請參閱 注意燈號亮起 。
3	列印燈號 ：印表機開啓並準備好列印時一直呈藍色亮起，印表機正在列印或忙於自我維護時呈藍色閃爍。
4	相片修復燈號 ：相片修復功能開啓時一直呈藍色亮起。
5	記憶卡燈號 ：插入記憶卡時一直呈藍色亮起，當印表機存取記憶卡時會閃爍，未插入記憶卡或插入超過一張記憶卡時會熄滅。請參閱印表機螢幕以取得相關指示。

選用配件

印表機有一些選用配件可增強便攜性，以便在任何時間和地點列印。配件的外觀可能與顯示的有所不同。

要購買耗材，請瀏覽：

- www.hpshopping.com (美國)
- www.hp.com/go/supplies (歐洲)
- www.hp.com/jp/supply_inkjet (日本)
- www.hp.com/paper (亞太地區)

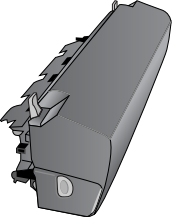
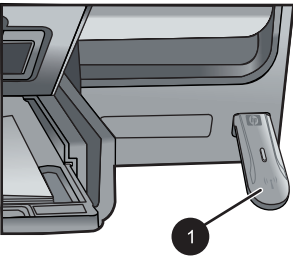
配件名稱	描述		
 <p data-bbox="224 743 463 769">HP 自動雙面列印配件</p>	<p data-bbox="686 494 1135 664">此配件會自動翻轉每頁以列印雙面。您可以節省費用 (雙面列印會減少紙張的消耗) 和時間 (無需取出紙張再將它重新放回)，並且更容易管理大型文件。並非在所有國家/地區都提供此配件。</p>		
 <p data-bbox="224 1072 585 1098">HP Bluetooth® 無線印表機轉接器</p> <table border="1" data-bbox="224 1107 665 1175"><tr><td data-bbox="233 1116 270 1142">1</td><td data-bbox="270 1116 658 1175">將 Bluetooth 轉接器插入前方相機連接埠</td></tr></table>	1	將 Bluetooth 轉接器插入前方相機連接埠	<p data-bbox="686 789 1135 1055">HP Bluetooth® 無線印表機轉接器需插入印表機前方的相機連接埠。此轉接器讓您從許多支援 Bluetooth 功能的裝置 (包括數位相機、照相機，以及 PDA) 使用 Bluetooth 無線技術列印。如需關於使用此配件進行列印的更詳細資訊，請瀏覽 www.hp.com/go/bluetooth。</p>
1	將 Bluetooth 轉接器插入前方相機連接埠		

印表機功能選項

按一下首頁按鈕以進入首頁畫面。您可以從首頁畫面及「設定」功能選項存取所有功能。

檢視與列印

「**精靈**」：使用精靈來引導您完成列印程序。也可使用精靈來改善相片品質，以及套用進階相片效果 (例如亮度及色彩效果)。

「**4x6**」：用於列印 4x6 英吋 (10 x 15 公分) 的相片。

「**放大**」：使用「放大」來列印不同尺寸的相片。

「**全部列印**」：選取後可列印插入印表機之記憶卡上的所有相片。

「**其他列印專案**」：使用「其他專案」來列印全景、HP CD/DVD 標籤、皮夾相片及護照相片。

- 「**全景列印**」：選取後可「**開啓**」或「**關閉**」(預設值) 全景列印。選取「**開啓**」以 3:1 的長寬比列印所有選取的相片；在列印之前放入 10 x 30 公分 (4 x 12 英吋) 的紙張。
- 「**HP CD/DVD 標籤**」：選取後可列印 CD/DVD 標籤。
- 「**皮夾相片**」：用於列印皮夾尺寸的相片。
- 「**護照相片**」：選取後可列印護照相片。

儲存檔案

選取「**儲存檔案**」，將您選取的影像儲存至連接的電腦上。

共享

使用「**共享**」，透過「HP Photosmart 共享」來選取並共享相片。

設定

- **工具**：使用工具來顯示墨水容量、調整列印品質、列印樣本頁、列印測試頁，以及清潔並校正墨匣。
 - 顯示墨水容量：用於在首頁畫面上顯示墨水容量。
 - 「**列印樣本頁**」：選取後可列印樣本頁，這在檢查印表機列印品質時很有用。此功能並未在所有印表機機型上提供。
 - 「**列印測試頁**」：選取後可列印包含有關印表機疑難排解資訊的測試頁。
 - 「**清潔列印頭**」：選取後可在相片上出現白色線條或條紋時清潔列印頭。完成清潔後，印表機將列印一份自我測試報告。如果報告顯示列印品質有問題，您可以選擇再次清潔列印頭。
 - 「**校正印表機**」：選取後可在相片上出現白色線條或條紋時校正印表機。
- **Bluetooth**
 - 「**裝置位址**」：某些具有 Bluetooth 無線技術的裝置需要您輸入要尋找之裝置的位址。此功能表選項會顯示印表機位址。
 - 「**裝置名稱**」：您可以為印表機選擇名稱，讓其他具有 Bluetooth 無線技術的裝置在找到印表機後顯示這個名稱。
 - 「**總金鑰**」：當印表機的 Bluetooth 「安全級別」設為「高」時，您必須輸入總金鑰才能讓其他 Bluetooth 裝置可以使用印表機。預設的總金鑰是 0000。
 - 「**可見性**」：選取「**全部可見**」(預設值) 或「**不可見**」。當「可見性」設為「不可見」時，只有知道印表機位址的裝置才能從印表機列印。

- 「安全級別」：選取「低」(預設值)或「高」。「低」設定不會要求使用 Bluetooth 無線技術之其他裝置的使用者輸入印表機總金鑰。「高」會要求使用 Bluetooth 無線技術之其他裝置的使用者輸入印表機總金鑰。
- 「重設 Bluetooth 選項」：選取後可將 Bluetooth 功能表中的所有項目重設為其預設值。
- **說明功能選項**：使用說明功能選項，取得印表機的使用指示。
 - 「墨匣」：選取後可看到如何安裝墨匣的動畫。
 - 「主紙匣放入」：選取後可閱讀在主紙匣中放入紙張的指示。
 - 「相片匣放入」：選取後可閱讀在相片匣中放入紙張的指示。
 - 「卡紙」：選取後可看到如何清除卡紙的動畫。
 - 「相機連接」：選取後可閱讀有關如何將 PictBridge 相機連接到印表機的指示。
- **偏好設定**
 - 4 x 6 列印紙張尺寸：選擇「**列印前詢問**」，以便在每次列印時選取紙張類型及尺寸(預設值)。
 - 「**列印品質**」：選擇「**最佳**」(預設值)或「**一般**」列印品質。
 - 「**紙張類型**」：選取「**自動**」(預設值)，印表機就會自動偵測紙張類型及尺寸。
 - 「**日期戳記**」：使用此選項可將日期與/或時間加到印好的相片上。
 - 色彩空間：選擇一個色彩空間。「自動選擇」(預設值)告訴印表機使用 Adobe RGB 色彩空間(如果可用)。如果無法使用 Adobe RGB，根據預設，印表機將會使用 sRGB。
 - PictBridge 紙匣選擇：用於選取在透過 PictBridge 連接列印時預設使用的紙匣。
 - 「**視訊增強**」：選取「**開啓**」(預設值)或「**關閉**」。當您選取「開啓」時，從視訊片段列印的相片品質會改善。
 - 「**還原原廠預設值**」：除了「**選取語言**」和「**選取國家/地區**」(在「**偏好值**」功能選項的「**語言**」中)以及 Bluetooth 設定(在印表機主功能選項的「**Bluetooth**」下)之外，將所有功能選項項目還原為其出廠時的預設設定。此設定不會影響「**HP Instant Share**」或「**網路**」預設值。

2 準備列印

本節包括下列主題：

- [放入紙張](#)
- [插入墨匣](#)
- [插入記憶卡](#)

放入紙張

了解如何為列印工作選擇合適的紙張，以及如何將紙張放入進紙匣以進行列印。

選擇適用的紙張

使用 HP 進階相紙。此種相紙是為與印表機中的墨水搭配使用所設計的，可以產生精美的相片。

如需可用 HP 相紙的清單，或是要購買耗材，請造訪：

- www.hpshopping.com (美國)
- www.hp.com/eur/hpoptions (歐洲)
- www.hp.com/jp/supply_inkjet (日本)
- www.hp.com/paper (亞太地區)

依預設，印表機會設定為在 HP 高級相紙上列印最佳品質的相片。如果您在不同種類的紙張上列印，請務必在印表機功能選項中變更紙張類型。請參閱[印表機功能選項](#)。

放入紙張訣竅

裝入紙張訣竅：

- 以列印面朝下的方式放入紙張。
- 您可以在各種尺寸的紙張上列印相片和文件，包括從 8 x 13 公分 (3 x 5 英吋) 到最大尺寸為 22 x 61 公分 (8.5 x 24 英吋) 的紙張。10 x 15 公分 (4 x 6 英吋) 相紙有含標籤或不含標籤兩種。
- 放入紙張前，先拉出主紙匣，然後將紙張寬度導板和紙張長度導板向外滑動，留出紙張的空間。放入紙張後，調整導板，使其緊靠紙張邊緣而不會彎曲紙張。紙張放入完成後，將主紙匣完全推回去。
- 一次僅在相同的紙匣中放入一種類型及尺寸的紙張。
- 放入紙張後，請拉出出紙匣延伸架，並將後檔板抬起以接住印好的頁面。

放入主紙匣

任何支援的相片或一般紙張材質

1. 拉出主紙匣。
2. 將紙張寬度導板和紙張長度導板滑動到最外邊的位置。
3. 以列印面朝下的方式放入紙張。請確認整疊紙輕靠在紙張長度導板上的固定夾下方。

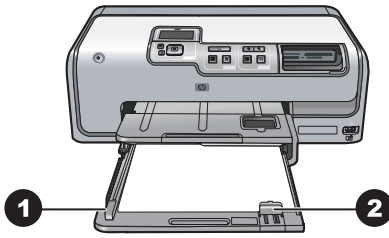

- | | |
|---|--------|
| 1 | 紙張寬度導板 |
| 2 | 紙張長度導板 |

4. 向內調整紙張寬度導板和紙張長度導板直到停在紙疊的邊緣。
5. 將主紙匣完全向內推入。

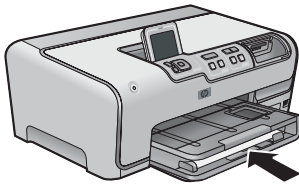

- | | |
|---|------------|
| 1 | 將主紙匣完全向內推入 |
|---|------------|

放入相片匣

可使用最大尺寸至 10 x 15 公分 (4 x 6 英吋) 含標籤或不含標籤的相紙、Hagaki 卡、A6 卡、L 尺寸卡。

1. 提起出紙匣並拉出相片匣。
2. 向外調整紙張寬度導板和紙張長度導板，留出紙張的空間。

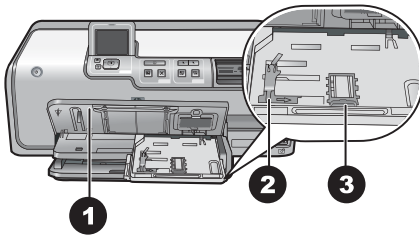

- | | |
|---|--------|
| 1 | 出紙匣 |
| 2 | 紙張寬度導板 |
| 3 | 紙張長度導板 |

3. 在相片匣中最多放入 20 張紙，並讓列印面朝下。如果使用含標籤的相紙，插入紙張時，請將含標籤那一側靠近您。
4. 向內調整紙張寬度導板和紙張長度導板直到停在紙疊的邊緣。請確認整疊紙輕靠在紙張長度導板上的固定夾下方。
5. 推入相片匣。
6. 關閉出紙匣。

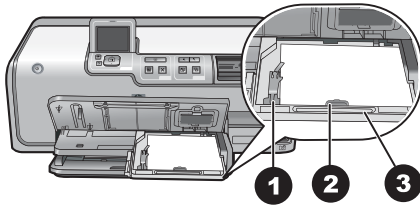

1	紙張寬度導板
2	紙張長度導板
3	相片匣把手

插入墨匣

在您第一次安裝與使用 HP Photosmart 時，請務必安裝印表機隨附的墨匣。這些墨匣中的墨水是特別配製與列印頭組件中的墨水混合。

購買替換墨匣

在購買替換墨匣時，請參閱本指南封底的墨匣編號。這些墨匣編號可能依國家/地區而異。



附註 如果您已多次使用印表機並且已安裝 HP Photosmart 印表機軟體，您也可以找到墨匣編號。 **Windows 使用者：**在 Windows 工作列中的 HP Digital Imaging Monitor 圖示上按一下滑鼠右鍵，然後選取「啟動/顯示 HP 解決方案中心」。選取「設定」，然後選取「列印設定」，再選取「印表機工具箱」。按一下「估計的墨水存量」標籤，然後按一下「墨匣資訊」。若要訂購墨匣，請按一下「線上訂購」。 **Mac 使用者：**在 Dock 中，按一下「HP Photosmart Studio」。在 HP Photosmart Studio 工具列中，按一下「Devices」（裝置）。從「Information and Settings」（資訊與設定）彈出式選單選擇「Maintain Printer」（維護印表機），然後按一下「Launch Utility」（啟動工具程式）。在「Configuration Settings」（組態設定）清單中，按一下「Supply Info」（耗材資訊）。

墨匣訣竅

HP Vivera 墨水提供逼真的相片品質以及傑出的防褪色效果，能永保持久的鮮豔色彩。HP Vivera 墨水是特別配製並已透過科學方法進行品質、純度和防止褪色方面的測試。

為了獲得最佳列印品質，對於從零售商處購買的所有列印墨匣，HP 建議您在包裝盒上的安裝有效期之前安裝。

為了獲得最佳列印效果，HP 建議您僅使用原廠 HP 墨匣進行列印。原廠 HP 墨匣是專為 HP 印表機設計，並通過在 HP 印表機上的測試，可在多次使用後仍能產生精美的列印效果。



附註 HP 無法保證非 HP 墨水的品質和可靠性。因使用非 HP 墨水導致印表機故障或損壞而引起的印表機服務或維修，不在保固範圍內。

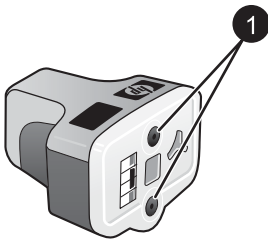

墨匣

- 1 請勿將物件插入這些孔內



注意 防止墨水流失或溢出：搬運印表機時，將墨匣留在印表機內，並且避免將用過的墨匣長時間留在印表機外。

墨匣保固資訊

當 HP 墨匣用於其專屬的 HP 列印裝置時，皆適用 HP 墨匣保固。此項保固不涵蓋重新填裝墨水、重新製造、重新換新、使用不當或經過改裝的 HP 墨水產品。在保固期限之內，只要 HP 墨水尚未用完或尚未超過保固到期日，產品都在保固範圍內。在產品上可以找到格式為 YYYY/MM/DD (年/月/日) 的保固到期日，如下圖所示：

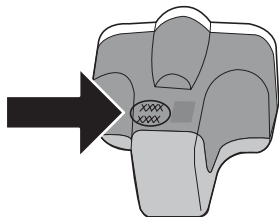

如需 HP 有限保固聲明的副本，請參閱 [HP 保固](#)。

插入或更換墨匣

1. 確定電源開啓，然後提起頂蓋。確定從印表機內部取出所有包裝材料。

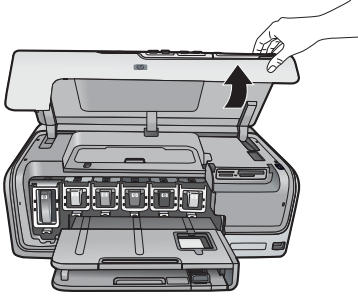

2. 擠壓墨匣插槽下面的灰色標籤以釋放印表機內部的灰色卡榫，然後提起卡榫。
墨匣區域具有顏色編碼以方便對照。提起適當顏色下面的卡榫以插入或更換墨匣。墨匣的顏色從左到右，分別是黑色、黃色、淡青藍色、青藍色、淡洋紅色及洋紅色。

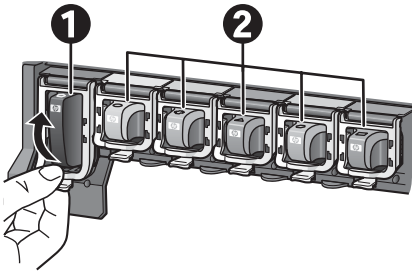

- | | |
|---|-----------|
| 1 | 黑色墨匣的墨匣卡榫 |
| 2 | 彩色墨匣的墨匣區域 |

3. 如果您要更換墨匣，請將舊墨匣朝向您自己方向拉出插槽以將它取出。

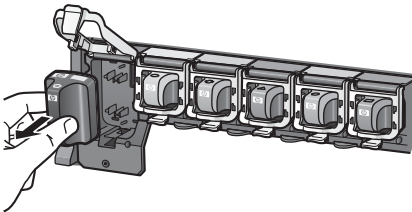

回收舊墨匣。HP 噴墨耗材回收計劃在許多國家/地區皆有提供，免費為您回收用過的墨匣。如需更詳細的資訊，請瀏覽 www.hp.com/hpinfo/globalcitizenship/environment/recycle/inkjet.html。

4. 從包裝中取出新的墨匣，握住把手，將墨匣滑入空的插槽。確定您插入墨匣的插槽具有與新墨匣相同形狀的圖示與顏色。在插入墨匣時銅色接點必須面向印表機。



附註 在您第一次安裝與使用印表機時，請務必安裝印表機隨附的墨匣。這些墨匣中的墨水是特別配製與列印頭組件中的墨水混合。

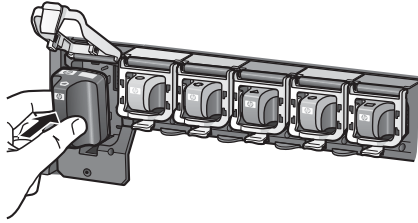

5. 將灰色卡榫向下壓直到它卡入到位。

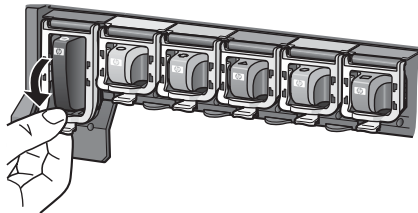

6. 為您要更換的每個墨匣重複步驟 2 至 5。
您必須安裝所有六個墨匣。如果有一個墨匣缺失，印表機將無法正常操作。
7. 合上頂蓋。

插入記憶卡

使用數位相機拍照之後，您可以從相機中取出記憶卡，將其插入印表機以檢視和列印相片。本款印表機可以讀取下列類型的記憶卡：**CompactFlash™**、**Memory Sticks**、**Microdrive™**、**MultiMediaCard™**、**Secure Digital™** 和 **xD-Picture Card™**。



注意 使用其他任何類型的記憶卡可能會損壞記憶卡和印表機。

若要了解如何用其他方法將數位相機中的相片傳輸到印表機，請參閱[連接到其他裝置](#)。

支援的檔案格式

此印表機可辨識下列檔案格式，並可直接從記憶卡列印：**JPEG**、未壓縮的 **TIFF**、**Motion JPEG AVI**、**Motion-JPEG Quicktime** 和 **MPEG-1**。如果您的數位相機以其他檔案格式儲存相片和視訊片段，請先將檔案儲存到電腦，再利用軟體程式進行列印。如需詳細資訊，請參閱電子版說明。

插入記憶卡

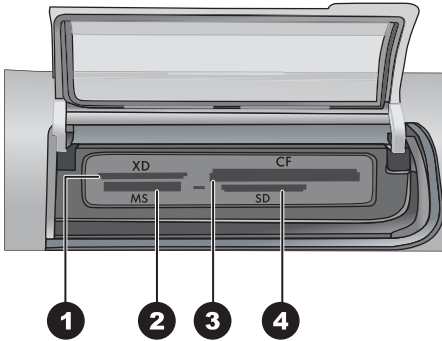

記憶卡插槽

1	xD-Picture Card
2	Memory Stick
3	Compact Flash I 和 II、Microdrive
4	Secure Digital、MultiMediaCard (MMC)

記憶卡類型

請在下表中尋找您的記憶卡，並按照相應的指示將記憶卡插入印表機。

操作指引：

- 一次僅插入一張記憶卡。
- 將記憶卡輕輕推入印表機，直到卡停住為止。記憶卡插槽只允許將部份記憶卡插入印表機；請勿嘗試硬將整個記憶卡插入印表機。
- 當記憶卡插入正確時，記憶卡燈號將會閃爍，然後一直亮起為綠色。



注意 1 使用任何其他方法插入記憶卡可能會損毀記憶卡和印表機。

注意 2 當記憶卡燈號呈綠色閃爍時，請勿拔出記憶卡。如需詳細資訊，請參閱[取出記憶卡](#)。

記憶卡	記憶卡插入方式
CompactFlash 	<ul style="list-style-type: none">● 正面標籤朝上，如果標籤有箭頭，箭頭應指向印表機● 有金屬針孔的一邊先插入印表機

記憶卡	記憶卡插入方式
<p>Memory Stick</p> 	<ul style="list-style-type: none">● 缺角在左邊● 金屬接點面朝下● 如果您使用 Memory Stick Duo 或 Memory Stick PRO Duo 卡，請先連接記憶卡隨附的轉接器，再將記憶卡插入印表機
<p>Microdrive</p> 	<ul style="list-style-type: none">● 正面標籤朝上，如果標籤有箭頭，箭頭應指向印表機● 有金屬針孔的一邊先插入印表機
<p>MultiMediaCard</p> 	<ul style="list-style-type: none">● 缺角在右邊● 金屬接點面朝下
<p>Secure Digital</p> 	<ul style="list-style-type: none">● 缺角在右邊● 金屬接點面朝下
<p>xD-Picture Card</p> 	<ul style="list-style-type: none">● 記憶卡弧形的一邊朝向您自己● 金屬接點面朝下

取出記憶卡

請等候至記憶卡指示燈停止閃爍，然後輕輕拔出以將其從印表機中取出。



注意 切勿在記憶卡指示燈閃爍時取出記憶卡。記憶卡指示燈閃爍表示印表機正在存取記憶卡。在記憶卡被存取時將其取出可能會損壞印表機，或者破壞記憶卡上的資訊。

3 列印相片時不連接電腦

HP Photosmart D7100 series 印表機甚至可讓您不必開啓電腦，便能選取、增強及列印相片。在您依照「快速入門」手冊中的指示設定印表機後，就可以將記憶卡插入印表機，然後使用印表機控制台上的按鈕來列印相片。

您也可以直接從數位相機列印相片。如需詳細資訊，請參閱[從數位相機列印相片](#)。

列印相片

按照下列數種方法，不使用電腦也可以列印相片：

- 將內含相片的記憶卡插入印表機的記憶卡插槽
- 將 PictBridge 數位相機連接到印表機前方的相機埠
- 安裝選購的 HP Bluetooth® 無線印表機轉接器，使用 Bluetooth 無線技術從數位相機列印

從記憶卡列印相片

您可以將記憶卡插入印表機以從記憶卡列印相片，並且使用印表機控制台檢視、選擇、增強以及列印相片。您也可以直接從記憶卡列印相機選擇的相片，亦即標示為使用數位相機列印的相片。

從記憶卡列印會很快速且便捷，而且不會耗盡數位相機的電池電力。

列印一張或多張相片

列印之前，請確定您已將記憶卡插入印表機，並已在要使用的紙匣中放入正確的紙張。

1. 選取「**檢視與列印**」，然後按「**OK**」。
2. 選取「**4x6**」，或選取「**放大**」以選擇您想要的相片尺寸，然後按「**OK**」。
3. 選取您想要的紙張尺寸，然後按「**OK**」。
4. 選取版面，然後按「**OK**」。
5. 使用箭頭按鈕，捲動所有可用的相片。
6. 按「**OK**」，選取一個或多個影像。
 - 按「**縮放 -**」，最多可在印表機螢幕上檢視 9 個影像。
 - 按向上鍵，增加選取影像的列印份數。
7. 按「**列印**」以列印選取的相片。

檢查相片匣指示燈確認已選取正確的紙匣；主紙匣指示燈應該熄滅，而相片匣指示燈則應亮起。

列印記憶卡上的所有相片

列印之前，請確定您已將記憶卡插入印表機，並已在要使用的紙匣中放入正確的紙張。

1. 選取「**檢視與列印**」，然後按「**OK**」。
2. 選取「**全部列印**」。
3. 選取您想要的紙張尺寸，然後按「**OK**」。
→ 選取版面，然後按「**OK**」。
4. 選取「**立即列印**」，然後按「**OK**」。

列印記憶卡中相機選擇的相片

當您使用數位相機選擇要列印相片時，該相機會建立數位列印順序格式 (DPOF) 檔案，用來標示選定的相片。印表機可以直接從記憶卡讀取 DPOF 1.0 及 1.1 的檔案。

1. 使用數位相機選取您要列印的相片。如需更詳細的資訊，請參閱相機隨附的文件。
2. 如果使用相機選取**預設**作為相片版面，請按「**版面**」以選取相片版面。如果使用相機選取**預設**以外的相片版面，則相片會以相機選擇的版面列印，而不考慮印表機設定。
3. 放入所需的紙張。
4. 從數位相機取出記憶卡，並將其插入印表機。
5. 當印表機螢幕上出現訊息詢問您是否要列印相機選擇的相片時，請按「**OK**」。

隨即便會開始列印您使用相機選擇的相片。

如果印表機找不到或無法讀取記憶卡上所有相機選擇的相片，它將只會列印可以讀取的相片。

列印完畢後，印表機便會刪除 DPOF 檔案，並取消相片的標記。

使用精靈進行列印

列印精靈提供對相片進行選取、調整大小、編輯及列印的詳細指示。



附註 也可使用精靈來改善相片品質，以及套用進階相片效果 (例如亮度及色彩效果)。

1. 選取「**檢視與列印**」，然後按「**OK**」。
2. 選取「**精靈**」，然後按「**OK**」。
3. 依照提示列印您想要的相片。

從視訊片段列印相片

您可以在印表機螢幕上檢視視訊片段，並選取及列印個別的畫面。

當您第一次插入含有視訊片段的記憶卡時，印表機會使用視訊片段的第一個畫面，在印表機螢幕上用來代表該片段。

印表機可以辨識以下列幾種格式錄製的視訊片段：

- Motion-JPEG AVI
- Motion-JPEG QuickTime
- MPEG-1

印表機會忽略其他格式的視訊片段。

列印之前，請確定您已將記憶卡插入印表機，並已在要使用的紙匣中放入正確的紙張。

1. 選取「**檢視與列印**」，然後按「**OK**」。
2. 選取「**4x6**」，或選取「**放大**」以選擇您想要的相片尺寸，然後按「**OK**」。
3. 選取您想要的紙張尺寸，然後按「**OK**」。
4. 使用向左鍵及向右鍵來捲動並選取可用的視訊。



附註 視訊會在影像中央顯示攝影機圖示。

5. 按向上鍵以播放視訊。
6. 若要選取想要列印的畫面，請按向上鍵以暫停視訊。您必須先暫停視訊，才能選取想要列印的畫面。
7. 按「**OK**」以選取您想要列印的畫面。
8. 按「**列印**」以列印選取的畫面。

列印相片索引頁

相片索引頁顯示記憶卡上最多 **2000** 張相片的縮圖檢視和索引編號。使用一般紙張而不是相紙來列印索引頁，可以節省成本。

相片索引頁可能長達數頁。

列印之前，請確定您已將記憶卡插入印表機，並已在要使用的紙匣中放入正確的紙張。

1. 選取「**檢視與列印**」，然後按「**OK**」。
2. 選取「**全部列印**」，然後按「**OK**」。
3. 選取 **8.5x11** 紙張。
4. 選取索引頁圖示 (每頁有 **16** 個影像)，然後按「**OK**」。

停止列印

若要停止進行中的列印工作，請按「**取消**」。

從數位相機列印相片

您可以使用 **USB** 纜線將 **PictBridge** 數位相機直接連接到印表機的相機連接埠進行相片列印。如果您的數位相機配備 **Bluetooth** 無線技術，則可以在印表機插入選購的 **HP Bluetooth®** 無線印表機轉接器，並以無線的方式傳送相片至印表機。從數位相機進行列印時，印表機會使用您在相機上選取的設定。如需更詳細的資訊，請參閱相機隨附的說明文件。

配備 Bluetooth 無線技術的數位相機

如果您的數位相機配備 Bluetooth 無線技術，則可以購買選購的 HP Bluetooth® 無線印表機轉接器，並使用 Bluetooth 無線連線從相機列印。



附註 您也可以使用 Bluetooth 無線技術從其他裝置列印，例如 PDA 或照相手機。如需詳細資訊，請參閱[連接到其他裝置與 Bluetooth 轉接器](#)隨附的說明文件。

1. 使用印表機螢幕上的 Bluetooth 功能選項為印表機設定 Bluetooth 選項。如需詳細資訊，請參閱[設定](#)。
2. 放入印表機紙張。
3. 將 HP Bluetooth® 無線印表機轉接器插入印表機**前方**的相機連接埠。當轉接器準備好接收資料時，轉接器上的指示燈會閃爍。
4. 按照數位相機隨附的說明文件中的指示，將相片傳送到印表機。

配備 PictBridge 技術的數位相機

1. 開啓 PictBridge 數位相機，並選取您想要列印的相片。
2. 放入紙張。
3. 確定相機在 PictBridge 模式下，然後使用相機隨附的 USB 纜線將相機連接到印表機**前方**的相機連接埠。
印表機辨識出 PictBridge 相機後，即會自動列印選定的相片。

從 iPod 列印相片

如果您有可以儲存相片的 iPod，則可將 iPod 連接到印表機並列印相片。

開始之前

檢查您複製到 iPod 的影像是否為 JPEG 格式。



附註 iPod 在您的國家/地區可能尚未提供。

將相片匯入 iPod



1. 使用 Belkin Media Reader for iPod 讀卡機將相片從記憶卡複製到您的 iPod。
2. 透過選取 iPod 選單上的「相片輸入」來確認相片已在 iPod 上。相片會顯示為「捲筒」。

從 iPod 列印相片



1. 使用 iPod 隨附的 USB 纜線，將 iPod 連接到印表機**前方**的相機連接埠。讀取相片時，印表機螢幕會顯示「正在讀取裝置」數分鐘。然後，相片會出現在印表機螢幕上。
2. 選擇您要列印的相片，並按「**列印**」。如需選取和列印相片的詳細資訊，請參閱[列印相片](#)。

相片版面

從「檢視與列印」功能選項選擇您想要的列印功能，再按「OK」選定所需的列印功能，然後選擇您想要的紙張尺寸與版面。

版面	紙張尺寸 (相片尺寸)
每頁 1 張相片，無邊框 	4 x 6 英吋 (4 x 6 英吋) 10 x 15 公分 (10 x 15 公分) 5 x 7 英吋 (5 x 7 英吋) 8.5 x 11 英吋 (8.5 x 11 英吋)
每頁 1 張相片 	3.5 x 5 英吋 (3.25 x 4.75 英吋) 4 x 6 英吋 (3.75 x 5.75 英吋) 10 x 15 公分 (9.53 x 14.6 公分) 5 x 7 英吋 (4.75 x 6.75 英吋) 8 x 10 英吋 (7.75 x 9.75 英吋) 8.5 x 11 英吋 (8 x 10 英吋) A6 (9.86 x 14.16 公分) A4 (20 x 25 公分) Hagaki (9.36 x 14.16 公分) L (8.25 x 12.06 公分)
每頁 2 張相片 	3.5 x 5 英吋 (2.25 x 3.25 英吋) 4 x 6 英吋 (2.75 x 3.75 英吋) 5 x 7 英吋 (3.25 x 4.75 英吋) 8 x 10 英吋 (4.75 x 6.5 英吋) 8.5 x 11 英吋 (5 x 7 英吋) A6 (6.92 x 9.86 公分) A4 (13 x 18 公分) Hagaki (6.8 x 9.36 公分) L (5.87 x 8.25 公分)
每頁 3 張相片	3.5 x 5 英吋 (1.5 x 2.25 英吋) 4 x 6 英吋 (1.75 x 2.625 英吋) 5 x 7 英吋 (2.25 x 3.375 英吋) 8 x 10 英吋 (3.33 x 5 英吋) 8.5 x 11 英吋 (4 x 6 英吋) A6 (4.77 x 7.15 公分)

(續)

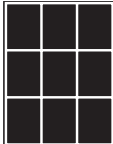
版面	紙張尺寸 (相片尺寸)
	A4 (10 x 15 公分) Hagaki (4.52 x 6.78 公分) L (3.96 x 5.94 公分)
每頁 4 張相片 	3.5 x 5 英吋 (1.5 x 2.25 英吋) 4 x 6 英吋 (1.75 x 2.5 英吋) 5 x 7 英吋 (2.2 x 3.25 英吋) 8 x 10 英吋 (3.5 x 4.75 英吋) 8.5 x 11 英吋 (3.5 x 5 英吋) A6 (4.77 x 6.92 公分) A4 (9 x 13 公分) Hagaki (4.52 x 6.5 公分) L (3.96 x 5.7 公分)
每頁 9 張相片 	3.5 x 5 英吋 (1 x 1.375 英吋) 4 x 6 英吋 (1.125 x 1.5 英吋) 5 x 7 英吋 (1.5 x 2 英吋) 8 x 10 英吋 (2.25 x 3 英吋) 8.5 x 11 英吋 (2.5 x 3.25 英吋) - 皮夾尺寸 A6 (3.07 x 4.05 公分) A4 (6.4 x 8.4 公分) Hagaki (2.9 x 3.86 公分) L (2.53 x 3.36 公分)



附註 印表機可能會旋轉相片以適合版面。

提高相片品質

印表機會提供數種增強功能，可提高從記憶卡列印的相片品質。這些列印設定不會變更原始相片。僅會影響列印。

調整亮度不足的相片

1. 選擇「**檢視與列印**」，然後按「**OK**」。
2. 選取「**精靈**」，然後按「**OK**」。
3. 依照螢幕指示來選取紙張尺寸及相片，然後按「**OK**」來檢視功能選項。
4. 選取「**編輯相片**」，然後按「**OK**」。

5. 選取「相片亮度」，然後按「OK」。
6. 按◀及▶，將相片亮度增減至您想要的程度，然後按「OK」。

消除相片中的紅眼

當您開啓「相片修復」功能時，便會啓用自動消除紅眼功能。啓用「相片修復」功能時，便會將智慧型聚焦、適應照明及消除紅眼功能套用於選取的相片上。

→ 按「相片修復」以啓用「相片修復」功能。

調整品質不佳的視訊片段

此偏好值會影響列印自視訊片段的相片。

提高列印自視訊片段的相片品質

1. 選取「設定」，然後按「OK」。
2. 使用箭頭按鈕尋找並選取「偏好設定」，然後按「OK」。
3. 使用箭頭按鈕尋找並選取「視訊增強」，然後按「OK」。
4. 選取「開啓」，然後按「OK」。

如需從視訊片段列印相片的資訊，請參閱[從記憶卡列印相片](#)。

使用創意

印表機提供多種工具與效果可讓您透過有創意的方式來處理您的相片。這些列印設定不會變更原始相片。僅會影響列印。

增加色彩效果

您可以設定印表機，將套用到相片的色彩選項從「彩色」(預設值)變更為「黑白」、「褐色」或「古董色」。

以「褐色」效果列印的相片呈褐色色調，看起來像二十世紀初期拍攝的相片。以「古董色」列印的相片呈現與褐色列印相同的褐色色調，但增加了一些灰白色，給人的感覺就像是手工上色的。

1. 選取「檢視與列印」，然後按「OK」。
2. 選取「精靈」，然後按「OK」。
3. 依照螢幕指示來選取紙張尺寸及相片，然後按「OK」。
4. 選取「完成選取」，然後按「OK」。
5. 選取「編輯相片」，然後按「OK」。
6. 選取「色彩效果」，然後按「OK」。
7. 選擇您想要的色彩效果，然後按「OK」。

在相片上增加日期和時間

您可以在相片正面列印戳記，顯示拍攝相片的時間。此偏好值將影響所有列印的相片。

1. 選取「設定」，然後按「OK」。
2. 使用箭頭按鈕尋找並選取「偏好設定」，然後按「OK」。

3. 選取「日期戳記」，然後按「OK」。
4. 選取下列其中一個日期/時間戳記選項：
 - 日期和時間
 - 日期
 - 關閉

如果您用電腦修改相片，然後儲存變更，則最初的日期和時間資訊將會遺失。用印表機控制台對相片所作的變更則不會影響日期和時間資訊。

變更列印品質

您可以變更相片的列印品質。「最佳」品質是預設設定，可印出品質最高的相片。「一般」品質可節省墨水，並加快列印的速度。

變更列印品質：

1. 選取「設定」，然後按「OK」。
2. 選取「偏好設定」，然後按「OK」。
3. 選取「列印品質」，然後按「OK」。
4. 選取您想要的列印品質，然後按「OK」。

下一次列印工作完成後，品質將還原為「最佳」。

裁剪相片

按「縮放 +」和「縮放 -」，按照 1.25x 的倍率增加或減少縮放倍數。倍數的上限為 5.0x。

1. 選取「檢視與列印」，然後按「OK」。
2. 選取「4x6」，或選取「放大」以選擇您想要的相片尺寸，然後按「OK」。
3. 選取您想要的紙張尺寸，然後按「OK」。
4. 選取您想要的相片，然後按「OK」。
5. 按「縮放 +」，按照 1.25x 的倍率增加相片的縮放倍數。綠色裁剪方塊將會出現。重複按「縮放 +」直到到達所要的放大倍數(放大相片之後，您可以透過按「縮放 -」將它縮小)。



附註 如果以選定的放大倍數列印會明顯降低列印品質，則裁剪方塊會從綠色變成黃色。

6. 在任何放大倍數下，均可使用箭頭向上、下、左、右移動裁剪方塊。
7. 要列印的影像部份在裁剪方塊中時，按「OK」。裁剪不會變更原始相片。僅會影響列印。

列印全景相片

1. 選取「檢視與列印」，然後按「OK」。
2. 選取「其他專案」，然後按「OK」。
3. 選取「全景列印」，然後按「OK」。
4. 依照提示放入 10 x 30 公分 (4 x 12 英吋) 材質，然後按「OK」。
5. 選取相片並按「OK」。如果需要的話，可在列印前裁剪相片。裁剪方塊具有 3:1 的長寬比。





附註 所有以全景模式列印的相片將列印為無邊框。

4 連接

使用印表機連接到其他裝置，或與他人保持聯繫。

連接到其他裝置

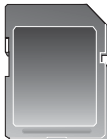
此印表機提供數種方式連接到電腦或其他裝置。每一種連接方式可讓您執行不同的作業。

連線類型與需要的配件	可讓您...
<p>記憶卡</p>  <p>記憶卡</p> <p>相容數位相機記憶卡</p> <p>將記憶卡插入印表機前方的適當記憶卡插槽中。</p>	<ul style="list-style-type: none">● 直接從記憶卡列印到印表機。● 將插入到印表機之記憶卡上的相片儲存到電腦，可以使用電腦上的 HP Photosmart Premier 或其他軟體來增強或整理相片。如需詳細資訊，請參閱將相片儲存到電腦和從記憶卡列印相片。
<p>USB</p> <ul style="list-style-type: none">● 通用序列匯流排 (USB) 2.0 全速相容纜線，長度不得超過 3 公尺 (10 英尺)。如需關於使用 USB 纜線連接印表機的指示，請參閱「快速入門」手冊。● 可以存取網際網路的電腦 (使用「HP Photosmart 共享」)。	<ul style="list-style-type: none">● 從電腦列印到印表機。請參閱從電腦列印。● 將插入到印表機之記憶卡上的相片儲存到電腦，可以使用電腦上的 HP Photosmart Premier 或其他軟體來增強或整理相片。● 透過「HP Photosmart 共享」共享相片。● 從 HP Photosmart 可直接列印的數位相機直接列印到印表機。如需詳細資訊，請參閱從數位相機列印相片與相機的說明文件。
<p>PictBridge</p>  <p>PictBridge 符號</p>	<p>直接從 PictBridge 相容數位相機列印到印表機。</p> <p>如需詳細資訊，請參閱從數位相機列印相片與相機的說明文件。</p>

(續)

連線類型與需要的配件	可讓您...
<p>PictBridge 相容數位相機與 USB 纜線。將相機連接到印表機前方的相機埠。</p>	
<p>Bluetooth 選購的 HP Bluetooth 無線印表機轉接器。 如果印表機附帶此配件，或者您有個別購買此配件，請參閱隨附的說明文件及線上說明以獲取相關指示。</p>	<p>從具備 Bluetooth 無線技術的任何裝置 (如數位相機、相機手機，或 PDA) 列印到印表機。 如果您在印表機的相機連接埠上連接選購的 HP Bluetooth 無線印表機轉接器，請確定已依需要設定了 Bluetooth 印表機功能選項。請參閱設定。</p>
<p>iPod iPod 與隨附的 USB 纜線。將 iPod 連接到印表機前方的相機連接埠。</p>	<p>直接從 iPod (有相片儲存在內) 列印到印表機。如需詳細資訊，請參閱從 iPod 列印相片。</p>

將相片儲存到電腦

如果您已透過 **USB 纜線** 連接印表機與電腦，則可將相片從插入印表機的記憶卡儲存到電腦。

如果您使用 **Windows 電腦**

使用其中一種方法將相片儲存到電腦。

- 將記憶卡插入印表機。HP Photosmart Premier 傳輸軟體 (HP 傳輸與快速列印) 會在電腦螢幕上開啓，並讓您指定要在電腦中儲存影像的位置。如需詳細資訊，請參閱螢幕 HP Photosmart 軟體說明。
- 將記憶卡插入印表機。記憶卡在 Windows 檔案總管中顯示為卸除式磁碟機。開啓卸除式磁碟機並將相片從記憶卡拖放到電腦中的任何位置。

如果您使用 **Macintosh**

1. 將記憶卡插入印表機。
2. 等待 iPhoto 開啓並讀取記憶卡上的內容。



附註 只有將 iPhoto 設定為預設的應用程式，它才會開啓。

3. 按一下「Import」(匯入) 將記憶卡上的相片儲存到 Macintosh。



附註 記憶卡也在桌面上顯示為一個磁碟機圖示。您可以開啓它並將相片從記憶卡拖放到 Macintosh 中的任何位置。

透過「HP Photosmart 共享」連接

使用「HP Photosmart 共享」，您可以透過電子郵件、線上相簿或線上相片沖印服務，與親朋好友分享相片。印表機必須透過 **USB 纜線** 連接到可以存取網際網路的電腦，並且電腦上必須已安裝全部 **HP 軟體**。如果您嘗試使用「共享」，但是沒有安裝或設定所有必要的軟體，系統會顯示訊息提示您完成所有必要的步驟。

使用「共享」(USB) 傳送相片 (Windows 使用者)：

1. 插入記憶卡並選取一些相片。
2. 選取印表機螢幕上的「共享」，然後按「OK」。
3. 依照電腦上的指示與其他人分享選定的相片。

使用「共享」(USB) 傳送相片 (Mac 使用者)

1. 開啓「HP Photosmart Studio」並選取要共享的相片。如需有關 HP Photosmart Studio 的詳細資訊，請參閱 [HP Photosmart Premier \(Windows 使用者\)](#)。
2. 在 HP Photosmart Studio 工具列中，按一下「Share」(共享)。
3. 按一下「Continue」(繼續)，並且依照電腦上的指示，與其他人共享選取的相片。

如需使用「HP Photosmart 共享」的詳細資訊，請參閱螢幕軟體說明。

5 從電腦列印

若要從電腦列印，電腦中必須已安裝印表機軟體。安裝軟體期間，若電腦已安裝 HP Photosmart Premier (Windows 完整安裝的使用者)、HP Photosmart Essential (Windows 快速安裝的使用者) 或是 HP Photosmart Studio (Mac)，您便能夠組織、共享、編輯以及列印相片。

如需安裝軟體的詳細資訊，請參閱「快速入門」。經常更新軟體可以確保您擁有最新的改進功能；如需相關指示，請參閱[更新軟體](#)。

若要處理相片，您需要將它們傳輸到與印表機相接的電腦上。請參閱[將相片儲存到電腦](#)。



附註 Windows 使用者：HP Photosmart Premier 僅可以在具備 Intel® Pentium® III (或同等級) 以及更快處理器的電腦上使用。

使用印表機軟體中的創意選項

閱讀這些訣竅，以了解如何開啓與使用 HP Photosmart Premier、HP Photosmart Essential、HP Photosmart Studio (Mac)，以及 HP Photosmart 共享。

HP Photosmart Premier (Windows 使用者)

HP Photosmart Premier 是一個易於使用的軟體程式，除了提供基本的相片編輯與列印功能之外，還提供獲得相片樂趣所需的一切功能。此軟體也可讓您存取「HP Photosmart 共享」，以供您輕鬆地共享相片。

開啓 HP Photosmart Premier

→ 連按兩下桌面上的「HP Photosmart Premier」圖示。如果您需要協助，請參閱 HP Photosmart Premier 中的軟體說明。

探究 HP Photosmart Premier 的多種功能：

- **檢視** — 以多種尺寸和方式檢視相片。輕鬆地整理和管理您的相片。
- **編輯** — 裁剪相片和消除相片的紅眼。自動以不同尺寸和多種版面調整和增強相片。
- **列印** — 以不同尺寸和多種版面列印相片。
- **共享** — 使用「HP Photosmart 共享」將相片傳送給親朋好友，而不需要大型附件，這是比傳送電子郵件更好的方式。
- **創意** — 輕鬆地製作相簿頁、卡片、日曆、全景相片、CD 標籤等。
- **備份** — 製作相片備份以供儲存。

HP Photosmart Essential (Windows 使用者)

HP Photosmart Essential 是一個易於使用的軟體程式，可提供基本的相片編輯和列印功能。此軟體也可讓您存取 HP Photosmart 共享，以供您輕鬆地共享相片。HP Photosmart Essential 僅為 Windows 使用者提供。

開啓 HP Photosmart Essential

→ 連接兩下桌面上的「HP Photosmart Essential」圖示。如果您需要協助，請參閱 HP Photosmart Essential 中的軟體說明。

探究 HP Photosmart Essential 的多種功能：

- **檢視** — 以多種尺寸和方式檢視相片。輕鬆地整理和管理您的相片。
- **編輯** — 裁剪相片和消除相片紅眼。自動調整和增強相片讓相片更完美。
- **列印** — 以不同尺寸和多種版面列印相片。
- **共享** — 藉由「HP Photosmart 共享」將相片傳送給親朋好友，而不需要大型附件，這是比傳送電子郵件更好的方式。

HP Photosmart Studio (Macintosh 使用者)

→ 在 Dock 中按一下「HP Photosmart Studio」圖示。

探究 HP Photosmart Mac 軟體的多種功能 (可從 HP Photosmart Studio 存取)：

- **Import (匯入)** — 從 HP 數位相機匯入相片或視訊。
- **View and Manage (檢視與管理)** — 檢視、整理及管理您的相片及視訊。
- **Edit (編輯)** — 調整並增強影像。
- **Slideshow (幻燈放映)** — 為您的相片製作線上幻燈放映。
- **Panorama (全景)** — 將數個影像製作成單一全景影像。
- **Create (創意)** — 製作相簿頁、卡片、標籤、海報、橫幅等。
- **Print (列印)** — 以標準尺寸或以相片目錄格式，列印相片和視訊中的畫面。
- **Share (共享)** — 將相片傳送給親朋好友，而不需要使用大型附件。
- **Shop (採購)** — 訂購線上列印品及禮物。

HP Photosmart 共享

「HP Photosmart 共享」可讓您將相片傳送給親朋好友，而不需要大型附件。如需詳細資訊，請參閱[透過「HP Photosmart 共享」連接與 HP Photosmart Premier 或 HP Photosmart Essential 的說明](#)。

開啓 HP Photosmart 共享 (Windows 使用者)

→ 按一下 HP Photosmart Premier 或 HP Photosmart Essential 中的「HP Photosmart 共享」標籤。

開啓 HP Photosmart 共享 (Mac 使用者)

→ 按一下 HP Photosmart Premier 中的「Applications」(應用程式) 標籤，然後連接兩下「HP Photosmart Share」(HP Photosmart 共享)。

設定列印偏好值

列印偏好值是預設值，但也可以更改以符合您的需要。當您從電腦列印時，可以設定特定的工作設定值。若您在列印前變更設定值，則該變更只會影響目前的列印工作。在一些 Windows 軟體程式中，您必須按一下「列印」對話方塊中的「內容」或「偏好值」，以存取進階列印功能。如需列印偏好值的詳細資訊，請參閱電子版說明。

存取列印偏好值 (Windows 使用者)

1. 開啓「列印」對話方塊，此操作通常透過在「檔案」功能表中選取「列印」執行。
2. 變更「列印」對話方塊標籤中的列印偏好值，或者按一下「內容」或「偏好值」存取更多列印偏好值。

存取列印偏好值 (Mac 使用者)

1. 開啓「列印」對話方塊，此操作通常透過在「檔案」功能表中選取「列印」執行。
2. 透過在「份數與頁數」下拉式功能表中選取您要變更的列印選項，來變更「列印」對話方塊中的列印偏好值。

如需變更列印偏好值的詳細資訊，請參閱電子版說明。

開啓電子版說明

Windows 使用者：

- 按下鍵盤上的 F1。
- 如需欄位級別說明，請按一下「列印」對話方塊右上角的「？」。

Mac 使用者：

1. 請從「Finder」中選擇「輔助說明」>「Mac 輔助說明」。
2. 從「資料庫」功能表中選擇「HP Photosmart Mac Help」(HP Photosmart Mac 輔助說明)，再從「HP Photosmart Mac Help」(HP Photosmart Mac 輔助說明) 目錄中選擇印表機名稱。

HP Real Life 技術功能

探究 HP Real Life 技術軟體功能中的眾多相片編輯和增強選項。這些功能，如自動消除紅眼和適應照明，讓您更容易列印高品質的相片。

共有三個選項可供使用：

- 「基本」設定能使影像清晰，並改善低解析度影像 (如從網際網路下載的影像) 的品質和清晰度。
- 「完整」設定能改善曝光不足或過度曝光、包含黑色區域或紅眼、或有看似褪色色彩的影像。
- 「關閉」設定可讓您在軟體程式中 (例如 HP Photosmart 軟體) 手動編輯影像。

存取 Real Life 技術功能 (Windows 使用者)

1. 開啓「列印」對話方塊，此操作通常透過在「檔案」功能表中選取「列印」執行。
2. 按一下「紙張/品質」標籤，然後按一下「Real Life 數位攝影」按鈕 一或者一 按一下「內容」或「偏好值」按鈕，然後按一下「Real Life 數位攝影」按鈕。

存取 Real Life 技術功能 (Mac 使用者)

1. 開啓「列印」對話方塊，此操作通常透過在「檔案」功能表中選取「列印」執行。
2. 在「份數與頁數」下拉式功能表中，選取「Real Life Digital Photography」(Real Life 數位攝影)。

6 愛護與維護

本款印表機並不需要特別維護。只要遵守本節介紹的指引說明，就可以延長印表機與列印耗材的使用期限，並確保最高品質的列印效果。

- [清潔及維護印表機](#)
- [更新軟體](#)
- [儲存及運送印表機和墨匣](#)
- [維護相紙的品質](#)

清潔及維護印表機

請使用本節說明的簡單程序，使印表機和列印墨匣常保清潔和最佳狀態。

清潔印表機外部

1. 關閉印表機的電源，然後拔掉接到印表機後方的電源線。
2. 使用稍微沾濕清水的軟布擦拭印表機外部。



注意 請勿使用任何種類的清潔劑，因為一般家用去污劑和清潔劑可能會損壞印表機的表面塗漆。請勿清潔印表機的內部。切勿讓任何液體流入印表機內部。請勿潤滑支撐列印頭滑動的金屬桿。列印頭前後滑動時產生噪音屬於正常現象。

校正印表機

如果自我測試報告顯示色塊有線條或白色條紋，請使用下列程序。

如果校正印表機後仍然有列印品質問題，請嘗試使用[愛護與維護](#)中描述的程序來清潔列印頭。若校正與清潔後，列印品質仍然有問題，請聯絡 **HP 支援**。

1. 將未使用的 **Letter** 或 **A4** 一般白紙放入主紙匣。
2. 選取「**設定**」，然後按「**OK**」。
3. 選取「**工具**」，然後按「**OK**」。
4. 捲動以找到並選取「**校正印表機**」。
印表機將會校正列印頭、列印校正頁，並校準印表機。請回收或丟棄校正頁。
5. 按「**OK**」。

列印樣本頁

您可以列印樣本頁來測試印表機的相片列印品質，並確認紙張是否正確放入。

1. 在主紙匣中放入紙張。使用一般紙張可以節省相紙。
2. 選取「**設定**」，然後按「**OK**」。
3. 選取「**工具**」，然後按「**OK**」。
4. 選取「**列印樣本頁**」，然後按「**OK**」。

自動清潔列印頭

如果您發覺列印的相片上或自我測試報告上的色塊中有白色線條或條紋，請使用此程序清潔列印頭。若非必要，請勿清潔列印頭，因為這麼做會浪費墨水以及縮短列印頭墨水噴嘴的使用壽命。

1. 在主紙匣中放入紙張。使用一般紙張可以節省相紙。
2. 選取「設定」，然後按「OK」。
3. 選取「工具」，然後按「OK」。
4. 選取「清潔列印頭」，然後按「OK」。



如果清潔列印頭之後，列印品質仍然不佳，請嘗試使用[校正印表機](#)中描述的程序來校正印表機。若清潔與校正後，列印品質仍然有問題，請聯絡 HP 支援。

手動清潔墨匣的接點

如果印表機螢幕上出現訊息指明墨匣找不到或損壞，請清潔墨匣的銅色接點。

清潔墨匣的接點前，先取出墨匣並確認墨匣的接點或墨匣插槽沒有被任何東西覆蓋，然後再重新安裝墨匣。如果您繼續收到一則訊息指明墨匣找不到或損壞，請清潔墨匣的接點。如果清潔接點後仍然收到此訊息，您就必須更換墨匣。取出有問題的墨匣，並查看底部 YYYY/MM/DD (年/月/日) 格式的保固到期日。若仍在保固期限內，請聯絡 HP 支援中心，以取得替換的墨水匣。

清潔墨匣的接點：

1. 請備齊下列物件來清潔接點：
 - 蒸餾水、過濾水，或瓶裝水 (自來水中可能含有會損壞墨匣的物質)
-  **注意** 請勿使用平板玻璃清潔劑或酒精來清潔墨匣的接點。這會損壞墨匣或 HP Photosmart。
- 使用不會分離或留下纖維的乾泡棉橡膠棒、無棉絮擦布，或任何柔軟的材料。
2. 打開印表機頂蓋。
 3. 緊壓墨匣插槽下面的灰色卡扣門鎖以釋放印表機內部的灰色卡榫，然後提起卡榫。
-  **注意** 請勿同時取出多個墨匣。一次只取出和清潔一個墨匣。切勿將墨匣留在印表機外超過 30 分鐘。
4. 用清水稍微沾濕棉花棒或擦布，並擠出多餘的水份。
 5. 握住墨匣的把手，用棉花棒或擦布輕輕擦拭銅色接點。

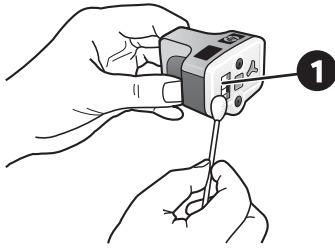

1 輕輕擦拭銅色接點

6. 將墨匣放回空的插槽，然後將灰色閘鎖向下壓直到它卡入到位。
7. 依需要為其他墨匣重複上述步驟。
8. 合上頂蓋。



注意 墨匣內有壓力。在墨匣中插入異物將造成墨水溢出並接觸到人體或物體。

列印自我測試報告

如果您遇到列印問題，請列印自我測試報告。此兩頁報告 (稱為擴充自我測試診斷頁) 可以幫助您診斷列印問題，並在您需要致電 HP 支援時提供有用的資訊。您也可以使用此報告來查看墨匣中剩餘的大約墨水存量。

1. 選取「設定」，然後按「OK」。
2. 選取「工具」，然後按「OK」，再捲動至列印測試頁。
3. 選取「列印測試頁」，然後按「OK」。

HP Photosmart 所列印的兩頁自我測試報告包含以下資訊：

- **產品資訊**：包括機型號碼、序號，以及其他產品資訊。
- **版本資訊**：包括韌體版本編號，並指明是否已安裝 HP 雙面列印配件 (雙面列印器)。
- **供墨系統資訊**：顯示每個已安裝墨匣的大約墨水存量、墨匣狀態、安裝日期，以及有效使用期限。
- **列印頭組件資訊**：包含在您需要致電 HP 支援時用於診斷目的的資訊。
- **列印頭參數**：包含在您需要致電 HP 支援時用於診斷目的的資訊。
- **列印品質圖樣**：顯示六個色塊，各代表六個已安裝的墨匣。當色塊出現條紋，或遺失色塊，請使用 [愛護與維護](#) 中描述的程序來清潔列印頭。如果清潔列印頭之後，色塊仍然顯示列印品質問題，請使用 [校正印表機](#) 中描述的程序來校正印表機。若清潔與校正後，色塊仍顯示列印品質有問題，請聯絡 HP 支援。
- **歷史記錄**：包含在您需要致電 HP 支援時用於診斷目的的資訊。

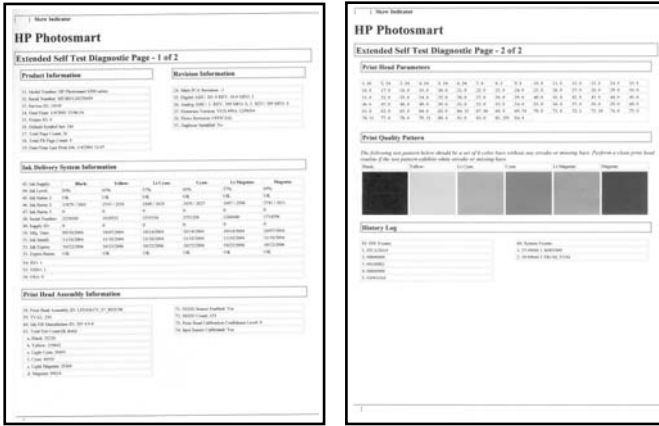

自我測試報告

更新軟體

請定期下載最新的印表機軟體更新程式，以確保您擁有最新的改進功能。您可以造訪 www.hp.com/support 或使用「HP 軟體更新程式」，下載印表機軟體的更新程式。



附註 您從 HP 網站下載的印表機軟體更新程式無法更新 HP Photosmart Premier 軟體。

下載軟體 (Windows)



附註 在使用「HP 軟體更新程式」之前，請確定已連線至網際網路。

1. 從 Windows「開始」功能表中，選取「程式集」(在 Windows XP 中，選取「所有程式」) > 「Hewlett-Packard」 > 「HP 軟體更新程式」。螢幕上將會開啓「HP 軟體更新程式」視窗。
2. 按一下「立即檢查」。「HP 軟體更新程式」將會搜尋 HP 網站以進行印表機軟體更新。如果電腦上沒有安裝最新版本的印表機軟體，「HP 軟體更新程式」視窗中會顯示軟體的更新程式。



附註 如果電腦上已安裝最新版本的印表機軟體，「HP 軟體更新程式」視窗中會顯示下列訊息：「此時沒有適用於您系統的更新程式」。

3. 如果有軟體更新程式，請按一下軟體更新程式旁邊的核取方塊以選取它。
4. 按一下「安裝」。
5. 依照螢幕上的指示完成安裝。

下載軟體 (Mac)



附註 在使用 HP Photosmart Updater (HP 更新程式) 之前，請確定已連線至網際網路。

1. 在 Mac 的 Finder 中，選取「前往」>「應用程式」。
2. 選取「Hewlett-Packard」>「Photosmart」>「HP Photosmart Updater」(HP 更新程式)。
3. 依照電腦螢幕上的指示檢查軟體更新程式。
如果系統受防火牆的保護，您需要在更新工具中輸入代理伺服器資訊。

儲存及運送印表機和墨匣

印表機和墨匣不用時，請妥善儲存以保護它們。

儲存及運送印表機

此印表機能夠短時間或長時間放置不使用。請將印表機儲存在室內，遠離直射的日光，並避免溫度過冷過熱。



注意 防止墨水遺失或溢出：請勿將印表機傾斜放置，儲存及運送印表機時請將墨匣留在印表機內裝好。

儲存及運送墨匣

儲存及運送印表機時，一定要將所用的列印墨匣留在印表機內，以免墨水乾掉。



注意 1 防止墨水遺失或溢出：儲存及運送印表機時，請將墨匣留在印表機內，並且避免將用過的墨匣長時間留在印表機外面。

注意 2 請確定印表機在拔下電源線前已完成電源關閉程序。這樣可使印表機正確地存放列印頭。

遵循以下訣竅將有助於維護 HP 墨匣，並確保一致的列印品質：

將所有還未使用的墨匣都儲存在原始的密封包裝盒中，直到要使用時再取出來。請在室溫下保存墨匣 (攝氏 15 - 35 度或華氏 59 - 95 度)。

維護相紙的品質

為使相紙呈現最佳列印效果，請遵循這一節的指引說明。

儲存相紙

- 相紙應儲存在原始包裝袋或可重複密封的塑膠袋中。
- 封裝好的相紙應平放在乾燥涼爽處。
- 未使用的相紙應放回塑膠袋中。若將相紙留在印表機內，或暴露在空氣中，相紙可能會開始捲曲。

拿取相紙

- 拿取相紙時只能碰觸相紙邊緣，以免留下指紋。
- 如果相紙邊緣捲曲，請將相紙放回塑膠袋中，輕輕向捲曲相反的方向折彎，直到紙張平整。

7 疑難排解

HP Photosmart 印表機效能可靠，易於使用。本章回答有關使用印表機及不連接電腦進行列印的常見問題，包含有關以下主題的資訊：

- [印表機硬體問題](#)
- [列印問題](#)
- [錯誤訊息](#)

如需其他疑難排解資訊，請參閱：

- **軟體安裝疑難排解**：印表機隨附的「快速入門指南」。
- **印表機軟體和從電腦列印之疑難排解**：螢幕「HP Photosmart 印表機說明」。如需檢視螢幕 HP Photosmart 印表機說明的詳細資訊，請參閱[歡迎](#)。

印表機硬體問題

在聯絡 HP 支援中心之前，請先閱讀本節內容以取得疑難排解訣竅，或瀏覽 www.hp.com/support 尋求線上支援服務。



附註 如果您要利用 USB 纜線將印表機連接到電腦，HP 建議使用長度不超過 3 公尺 (10 英呎) 的 2.0 高速相容纜線。

列印燈號呈藍色閃爍，但印表機不列印

解決方案 印表機正在處理資訊；請等到它完成。

注意燈號亮起

解決方案

- 查看印表機螢幕以取得相關指示。如果印表機有連接數位相機，請查看相機螢幕以取得相關指示。如果印表機有連接電腦，請查看電腦顯示器以取得相關指示。
- 關閉印表機，然後拔下電源線。等候大約 10 秒鐘，然後重新插上電源線。開啓印表機。

如果嘗試以上解決方法後，注意燈號仍然一直亮起，請造訪 www.hp.com/support，或聯絡 HP 支援以取得協助。

印表機找不到我儲存在記憶卡上的相片

解決方案 記憶卡所包含的檔案類型，可能不是印表機可以直接從記憶卡讀取的類型。

- 將相片儲存到電腦，再從電腦列印相片。如需詳細資訊，請參閱螢幕 HP Photosmart 說明和相機隨附的說明文件。
- 下一次拍照時，修改數位相機的設定，使相片儲存成印表機可以直接從記憶卡讀取的檔案類型。如需支援的檔案格式清單，請參閱[印表機規](#)

格。如需設定數位相機以將相片儲存為特定檔案格式的說明，請參閱相機隨附的說明文件。

如果問題仍然存在，可能需要重新格式化記憶卡。

印表機已連接電源線，卻無法開啓

解決方案

- 印表機可能消耗太多電源。請拔掉印表機的電源線。等候大約 10 秒鐘，再插回電源線，然後開啓印表機。
 - 印表機可能插入已關閉電源的插線板。請先開啓插線板的電源，再開啓印表機的電源。
 - 電源線可能已經損壞。請確定電源線上的綠燈有亮起。
-

印表機在開啓電源時發出噪音，或靜置一陣子之後開始發出噪音

解決方案 當印表機靜置很長一段時間 (大約 2 個星期) 之後，或是停電又恢復電力時，可能會發出噪音。這是正常作業。印表機正在執行自動維護程序，以確保最佳品質的列印輸出。

印表機上的所有指示燈在閃爍

解決方案 印表機遇到硬體錯誤的問題，並且可能需要維修。請拔掉印表機的電源線。等候大約 10 秒鐘，然後重新插上電源線。開啓印表機。如果指示燈仍在閃爍，請造訪 www.hp.com/support，或聯絡 HP 支援以取得協助。

列印問題

在聯絡 HP 支援中心之前，請先閱讀本節內容以取得疑難排解訣竅，或瀏覽 www.hp.com/support 尋求線上支援服務。

我從控制台列印時，印表機沒有列印無邊框相片

解決方案 在設定列印工作時，請確定已選取正確的版面。選取相片與紙張尺寸時，影像矩形框必須完全填滿橘色，以表示無邊框列印。

列印速度非常慢

解決方案 可能是下列其中一種情況：1) 您可能正在列印包含高解析度的圖形或相片的 PDF 或專案；2) 您可能為列印輸出選擇了最高的解析度。列印含有圖形或相片的大型複雜專案 (尤其是較高的解析度) 比列印純文字文件要慢。

紙張未從主紙匣正確送入印表機

解決方案

- 相紙匣中可能放入太多紙張。請取出一些紙張，再重新嘗試列印。
 - 主紙匣可能並未完全向內推入。請將主紙匣完全向內推入。
 - 紙張導板的調整可能不正確。請確定紙張寬度與紙張長度導板已靠緊紙張的邊緣並且沒有使紙張彎曲。
 - 兩張或多張紙可能黏在一起。請從主紙匣中取出紙張並將紙疊展成扇形以分開紙張，然後重新放入紙張並再次嘗試列印。
 - 如果紙張有皺摺或彎曲，請嘗試使用不同的紙張。
 - 紙張可能太薄或太厚。請使用 **HP 噴墨紙** 以得到最佳的列印效果。如需詳細資訊，請參閱 [選擇適用的紙張](#)。
-

列印頁從出紙匣中掉出

解決方案 列印時請務必將出紙匣延伸架拉出。

列印輸出皺摺或捲曲

解決方案 您正在列印的專案比一般專案耗用較多的墨水。請從電腦列印專案，並使用印表機軟體降低墨水飽和度。如需詳細資訊，請參閱螢幕 **HP Photosmart 說明**。

印出的文件歪斜，或沒有位於紙張的中央

解決方案

- 可能沒有正確地放入紙張。請重新放入紙張，確定紙張已按照正確的列印方向放入主紙匣，並且紙張寬度導板與紙張長度導板緊靠紙張邊緣。如需放入紙張的指示，請參閱 [放入紙張訣竅](#)。
 - 如果您使用了雙面列印配件，請嘗試將它取出，更換後方機門，然後再次列印。
 - 可能需要校正印表機。如需詳細資訊，請參閱 [校正印表機](#)。
-

列印的色彩不太令人滿意

解決方案

- 其中一個彩色墨匣可能已用盡，造成在列印時用另一種顏色來取代。請從「工具」功能選項檢視墨水存量圖示，檢查估計的墨水存量 (設定 > 工具 > 顯示墨水容量)。如果墨匣已空，則替換該墨匣。如需詳細資訊，請參閱 [插入墨匣](#)。
 - 可能需要校正印表機。如需詳細資訊，請參閱 [校正印表機](#)。
 - 可能需要清潔列印頭。如需詳細資訊，請參閱 [愛護與維護](#)。
-

列印時印表機沒有出紙或卡紙

解決方案

- 需要檢查印表機。請查看印表機螢幕以取得相關指示。
 - 電源可能關閉或連接不牢靠。請確定已開啓電源，而且電源線連接穩固。
 - 主紙匣或相片匣中可能沒有任何紙張。請檢查紙張是否正確放入。如需放入紙張的指示，請參閱[放入紙張訣竅](#)。
 - 若列印時出現卡紙，請嘗試下列步驟：
 - 關閉印表機，然後從電源插座中拔下印表機的電源線。清除印表機中所有可能阻塞進紙路徑的紙張。取下後方機門。輕輕地取出卡在印表機中的紙張，然後重新裝上後方機門。如果無法從印表機背面取出所有卡住的紙張，請嘗試透過打開位於頂蓋內部的卡紙門，取出卡在印表機中間的紙張。如需清除卡紙的兩個位置之圖示，請參閱[紙張錯誤](#)。當您完成清除卡紙後，插上印表機電源線然後開啓電源，再重新嘗試列印。
 - 如果列印標籤，請確定標籤紙通過印表機時標籤面沒有剝離。
-

印表機印出空白頁

解決方案

- 您可能已經開始列印，然後又取消該列印工作。
如果在開始列印前取消列印工作，印表機可能已經放入準備列印的紙張。下一次列印時，印表機在開始新列印專案前會先送出空白頁。
 - 具有大量資料的列印工作可能已傳送到印表機。
等待印表機維護列印頭後，再繼續列印。
-

印表機要求我列印校正頁

解決方案 印表機必須定期執行列印頭校正以維持最佳列印品質。
出現提示時，放入 **Letter** 或 **A4** 一般紙張。丟棄或回收校正頁。

相片沒有依預設列印設定來列印

解決方案 您可能已為選取的相片變更列印設定。您在個別相片上套用的列印設定取代了預設列印設定。請取消選取相片，以放棄所有套用於該個別相片的列印設定。如需詳細資訊，請參閱[設定](#)。

印表機準備列印時退出空白紙張

解決方案 日光直射可能影響自動紙張感應器的運作。請將印表機移到無日光直射的地方。

列印品質不佳

解決方案

- 其中一個彩色墨匣可能墨水量太低，造成在列印時用另一種顏色來取代。從「工具」功能選項檢視墨水存量圖示，檢查估計的墨水存量(設定 > 工具 > 顯示墨水容量)。如果墨匣中的墨水不足，請將它更換。如需詳細資訊，請參閱[插入墨匣](#)。
- 使用專為此印表機設計的相紙。為獲取最佳效果，請使用[選擇適用的紙張](#)中建議的紙張。
- 您可能列印在紙張的錯誤面上。請確定以列印面朝下的方式放入紙張。
- 您可能在數位相機上選擇了低解析度設定。請減少影像的大小並嘗試再次列印。為在以後獲得更好的效果，請將數位相機設定為較高的相片解析度。
- 墨匣或列印頭可能有問題。請嘗試執行下列步驟：
 - 一次取出一個墨匣，然後再重新插入以確定每個墨匣都正確安裝。
 - 執行自動列印頭清潔程序。如需詳細資訊，請參閱[愛護與維護](#)。
 - 校正印表機。如需詳細資訊，請參閱[校正印表機](#)。
 - 嘗試以上的所有解決方法之後，如果列印品質問題仍然存在，請聯絡 HP 支援。

相片未正確列印

解決方案

- 您可能沒有正確地放入相紙。請以列印面朝下的方式放入相紙。
- 相紙可能沒有正確地送入印表機。請嘗試執行下列步驟：
 - 檢查是否卡紙。如需詳細資訊，請參閱[紙張錯誤](#)。
 - 將相紙儘量往內插入相片匣。
 - 一次只放入一張相紙。

在數位相機中標記要列印的相片沒有列印

解決方案 某些數位相機可以讓您標記相機內部記憶體和記憶卡上之相片以進行列印。如果您在內部記憶體標記相片，然後將相片從相機的內部記憶體移到記憶卡上，標記不會隨之轉移。請將相片從相機內部記憶體轉移到記憶卡之後，再標記要列印的相片。

錯誤訊息

在聯絡 HP 支援中心之前，請先閱讀本節內容以取得疑難排解訣竅，或瀏覽 www.hp.com/support 尋求線上支援服務。

在印表機螢幕上出現的錯誤訊息可以分為以下類型：

- [紙張錯誤](#)
- [墨匣錯誤](#)

- 記憶卡錯誤
- 電腦列印錯誤

紙張錯誤

在聯絡 HP 支援中心之前，請先閱讀本節內容以取得疑難排解訣竅，或瀏覽 www.hp.com/support 尋求線上支援服務。

錯誤訊息：卡紙。清除卡紙然後按下「OK」。

解決方案 關閉印表機，然後從電源插座中拔下印表機的電源線。清除印表機中所有可能阻塞紙張路徑的紙張。卸下後方機門。輕輕地取出卡在印表機中的紙張，然後重新裝上後方機門。

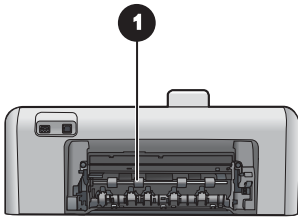

1 取下後方機門可以清除卡紙。

如果您無法從印表機後方取出所有卡住的紙張，請嘗試透過打開位於頂蓋內部的卡紙門，取出卡在印表機中間的紙張。

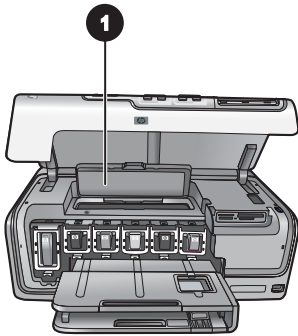

1 打開卡紙門可以清除印表機中間的卡紙。

插上印表機電源線然後開啓電源。

錯誤訊息：紙張用完。放入紙張然後按「OK」。

解決方案 放入紙張，然後按「OK」以再次列印。如需放入紙張的指示，請參閱[放入紙張訣竅](#)。

錯誤訊息：不支援的材質尺寸。

解決方案 印表機無法使用紙匣中放入的紙張尺寸。按「**OK**」，然後放入支援的紙張尺寸。如需支援的紙張尺寸清單，請參閱[印表機規格](#)。

錯誤訊息：自動紙張感應器失效。

解決方案 自動紙張感應器阻塞或損壞。嘗試將印表機移到不受日光直射的地方，然後按「**OK**」並嘗試再次列印。如果此方法無效，請造訪www.hp.com/support 或聯絡 HP 支援。

墨匣錯誤

在聯絡 HP 支援中心之前，請先閱讀本節內容以取得疑難排解訣竅，或瀏覽www.hp.com/support 尋求線上支援服務。

錯誤訊息：安裝了錯誤的墨匣

解決方案 在您第一次安裝與使用 HP Photosmart 印表機時，請確定安裝印表機隨附的墨匣。這些墨匣中的墨水是特別配製與列印頭組件中的墨水混合。

若要解決這個問題，請使用 HP Photosmart 印表機隨附的墨匣來更換有問題的墨匣。

如需更換墨匣的詳細資訊，請參閱[插入墨匣](#)。

錯誤訊息：不正確的墨匣

解決方案 裝置起始化之後無法再使用指定的墨匣。為 HP Photosmart 更換適當的墨匣。您可以在此印表機中使用的墨匣編號印在此印刷版指南的封底頁面上。

如需更換墨匣的詳細資訊，請參閱[插入墨匣](#)。

錯誤訊息：請儘快更換墨匣

解決方案 指定的墨匣已空。

您也許可以用列印頭組件中剩餘的墨水，再繼續列印一段很短的時間。更換指定的墨匣或按「**OK**」繼續。

如需更換墨匣的詳細資訊，請參閱[插入墨匣](#)。

錯誤訊息：墨匣已空

解決方案 指定的墨匣已空，而且列印頭中沒有足夠的墨水可供一般的列印或維修工作。使用新墨匣替換指定的墨匣。

- 如果黑色墨匣是空的，您可以透過選擇印表機螢幕提示的選項繼續以其他彩色墨匣進行列印。
- 如果彩色墨匣是空的，您可以透過選擇印表機螢幕提示的選項繼續以黑色墨匣進行列印。

取決於列印工作的狀態，您可以按「**OK**」繼續。如果 HP Photosmart 在列印工作的中途，請按「**取消**」然後重新開始列印工作。



附註 文字與相片品質在使用所有墨匣列印時會有所不同。如果沒有儘快更換空墨匣，所有列印作業將停止。

如需更換墨匣的詳細資訊，請參閱[插入墨匣](#)。

錯誤訊息：無法列印

解決方案 有關的墨匣已無墨水。

立即更換有關的墨匣以便您可以繼續列印。

HP Photosmart 在替換指定的墨匣前，無法繼續列印。所有列印作業將停止。

如需更換墨匣的詳細資訊，請參閱[插入墨匣](#)。

錯誤訊息：墨匣問題

解決方案 有關的墨匣找不到或損壞。

立即更換指定的墨匣以便您可以繼續列印。如果 HP Photosmart 並沒有墨匣遺失，可能必須清理墨匣接點。

如需更換墨匣的詳細資訊，請參閱[插入墨匣](#)。如需清潔墨匣接點的詳細資訊，請參閱[愛護與維護](#)。

如果 HP Photosmart 印表機並沒有墨匣遺失，而您在清潔墨匣接點後仍然收到此訊息，您就必須更換墨匣。取出有問題的墨匣，並查看底部 YYYY/MMM/DD (年/月/日) 格式的保固到期日。若仍在保固期限內，請聯絡 HP 支援，取得替換的墨水匣。

錯誤訊息：墨水使用期限即將到期。— 或者 — 墨匣已過期。

解決方案 每個墨匣都有使用期限。使用期限的目的在於保護列印系統，並且確保墨水品質。當您收到墨水到期的訊息時，請移除墨匣並更換新墨匣，再關閉訊息。您也可以藉由依照電腦螢幕上的指示，不需更換墨匣就可以繼續列印。HP 建議您更換過期的墨匣。HP 無法保證過期墨匣的品質或可靠性。因為使用過期墨水而導致裝置需要維修或修理，將不含在保固範圍內。

如需更換墨匣的詳細資訊，請參閱[插入墨匣](#)。

錯誤訊息：非 HP 墨水

解決方案 更換指定的墨匣或按「OK」繼續。

HP 建議您使用原廠 HP 墨匣。原廠 HP 墨匣都使用 HP 印表機設計與測試以讓您輕易獲得永遠傑出的效果。



附註 HP 無法保證非 HP 墨水的品質或可靠性。如果印表機因為使用非 HP 墨水出問題或受損而必須進行的印表機維修或修理將不包括在保固範圍內。

如果您肯定自己購買了原廠 HP 墨匣，請瀏覽：

www.hp.com/go/anticounterfeit

錯誤訊息：原有的 HP 墨水已經耗盡

解決方案 更換指定的墨匣或按「OK」繼續。

HP 建議您使用原廠 HP 墨匣。原廠 HP 墨匣是專為 HP 印表機設計，並通過在 HP 印表機上的測試，可在多次使用後仍能產生精美的列印效果。



附註 HP 無法保證非 HP 墨水的品質或可靠性。因使用非 HP 墨水導致印表機故障或損壞而引起的印表機服務或維修，不在保固範圍內。

如果您確定自己購買的是原廠 HP 墨匣，請瀏覽：

www.hp.com/go/anticounterfeit

錯誤訊息：既定的維護程序

解決方案 您必須校正印表機以確保絕佳的列印品質。在主紙匣中放入未用過的 Letter 或 A4 一般白紙，按「OK」。HP Photosmart 將校正列印頭，校準印表機，然後列印測試頁。回收或丟棄測試頁。

錯誤訊息：校準錯誤

解決方案

- 如果校正印表機時主紙匣放入彩色紙張或相紙，校正可能會失敗。將未用過的 Letter 或 A4 一般白紙放入主紙匣，然後嘗試再次校正。如果校正再次失敗，可能是感應器或墨匣已損壞；請聯絡 HP 支援。
 - 墨匣或感應器損壞。請聯絡 HP 支援。
-

錯誤訊息：列印墨匣托架被卡住

解決方案 取出阻塞列印頭組件的任何物件。

清潔列印頭組件

1. 打開頂蓋，然後再打開卡紙門。

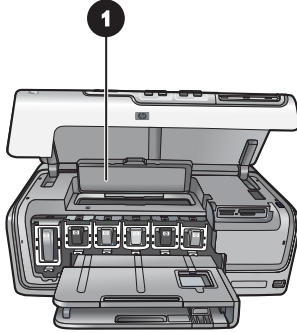

1. 打開卡紙門可以清潔列印頭組件。
2. 取出阻塞列印頭組件的任何物件，包括紙張和任何包裝材料。
3. 關閉印表機的電源，然後再次開啓電源。
4. 關閉卡紙門和頂蓋。

錯誤訊息：墨水系統故障

解決方案 列印頭零件或墨水傳送系統已經失效，同時 HP Photosmart 無法再列印。

關閉印表機，然後拔下電源線。等候大約 10 秒鐘，然後重新插上電源線。如果此方法無法清除錯誤訊息，請聯絡 HP 支援。

記憶卡錯誤

在聯絡 HP 支援中心之前，請先閱讀本節內容以取得疑難排解訣竅，或瀏覽 www.hp.com/support 尋求線上支援服務。

錯誤訊息：找不到相片。一或者一 某些相片找不到。

解決方案 印表機無法讀取記憶卡上的檔案，或者，為該作業指定的一個或多個檔案不在記憶卡上。嘗試使用數位相機而不是記憶卡將相片儲存到電腦中。如果是缺失相片，可能是您意外將相片從記憶卡刪除。

錯誤訊息：卡片存取錯誤。工作已取消。按下「OK」。 — 或者 — **檔案目錄結構受損。**
— 或者 — **卡片可能受損。工作已取消。按「OK」。**

解決方案 印表機無法讀取記憶卡上的資料，無法完成目前的列印工作。資料已損毀或記憶卡實體存在問題。

- 將檔案儲存至電腦，並從電腦存取。
- 若此方法無效，請使用新記憶卡或者使用數位相機重新格式化記憶卡。記憶卡上的所有相片都將丟失。
- 如果此方法無效，則相片檔案或許已損毀或無法讀取。在聯絡 HP 支援之前，請嘗試使用其他記憶卡來判斷是印表機還是記憶卡發生故障。

錯誤訊息：無法列印相片。

解決方案 列印工作指定的相片有超過 10 張以上可能已損壞、找不到或是屬於不支援的檔案類型。如需支援的檔案類型之詳細資訊，請參閱[印表機規格](#)。

- 使用數位相機而不是記憶卡將相片儲存到電腦中。
- 將檔案儲存至電腦，然後從電腦列印。
- 列印相片索引，然後重新選取相片。如需詳細資訊，請參閱[列印相片](#)。

錯誤訊息：卡片受密碼保護。無法存取卡片。

解決方案 插入的記憶卡受密碼保護，因此印表機無法讀取。請遵循下列步驟：

1. 從印表機中取出記憶卡。
2. 將記憶卡插入在原先將密碼儲存在記憶卡的裝置內。
3. 刪除記憶卡的密碼。
4. 取出記憶卡並將其重新插入印表機的記憶卡插槽。
5. 嘗試再次列印。

錯誤訊息：卡片被鎖定。無法存取卡片。

解決方案 確定記憶卡上的鎖定開關處於解鎖的位置。

錯誤訊息：卡片並未完全插入。將卡片往內推一點。

解決方案 印表機可以偵測到記憶卡但無法讀取。輕輕將記憶卡推入記憶卡插槽，直到卡停止移動。如需詳細資訊，請參閱[插入記憶卡](#)。

錯誤訊息：一次僅能使用一張卡片。請取出一張記憶卡。—或者—一次只能使用一部裝置。請卸下/斷開裝置。

解決方案 印表機中同時插有兩種或更多不同類型的記憶卡，或者插入記憶卡的同時有數位相機連接到相機連接埠。取出記憶卡或斷開相機，直到印表機中只剩一張卡或僅連接一台相機為止。

錯誤訊息：卡片已移除。工作已取消。按「OK」。

解決方案 當印表機正從記憶卡列印檔案時，您從印表機中取出了記憶卡。請遵循下列步驟：

1. 按「OK」。
2. 重新插入記憶卡，然後再次列印選定的相片。記憶卡必須在完成列印工作前保持插入狀態。

若要避免日後損壞記憶卡，在存取記憶卡時，請勿從印表機記憶卡插槽中將記憶卡取出。如需詳細資訊，請參閱[取出記憶卡](#)。

錯誤訊息：相機選擇的 (DPOF) 檔案有錯誤。

解決方案 由於資料損毀或記憶卡發生錯誤，印表機無法讀取 DPOF 檔案。請使用印表機控制台重新選取相片。如需詳細資訊，請參閱[從記憶卡列印相片](#)。

錯誤訊息：某些相機選擇的相片不在卡片中。

解決方案 某些相機選擇的相片找不到或者已刪除。請嘗試執行下列步驟：

- 確認您並未從記憶卡意外地刪除相片。
 - 使用數位相機再次重新選取相片。
 - 列印新的相片索引，以查看與每張相片相關的索引編號。如需詳細資訊，請參閱[列印相片](#)。
-

錯誤訊息：無法顯示這張相片。—或者—無法顯示所有相片。—或者—相片已損毀。

解決方案 記憶卡上包含印表機不支援的影像格式，或者檔案已經損毀。如需支援的影像格式清單，請參閱[印表機規格](#)。使用電腦存取相片。如需透過電腦存取相片的詳細資訊，請參閱[從電腦列印](#)。

錯誤訊息：不支援的卡片類型。

解決方案 使用相機將相片傳輸到電腦，然後從電腦列印。

錯誤訊息：某些相片號碼不在卡片中。

解決方案 使用相機將相片傳輸到電腦，然後從電腦列印。如果某些相片仍然找不到，它們可能已從記憶卡中刪除。

電腦和連線列印錯誤

在聯絡 HP 支援之前，請先閱讀本節以獲取疑難排解訣竅，或造訪 www.hp.com/support 尋求線上支援服務。

錯誤訊息：印表機記憶體已滿。工作被取消。按下「OK」。

解決方案 印表機在列印相片時遇到問題。請嘗試執行下列步驟：

- 若要清除印表機記憶體，請關閉印表機，然後再次開啓。
 - 一次列印較少的相片。
 - 將相片儲存至電腦，並從電腦列印。
 - 使用讀卡機將檔案儲存到電腦，然後從電腦列印。
-

錯誤訊息：通訊錯誤。檢查電腦連線。按下「OK」。—或者— 沒有收到資料。檢查電腦連線。按下「OK」以繼續。—或者— 電腦沒有回應。

解決方案 電腦無法與印表機進行正常通訊。可能是印表機軟體無法操作或者纜線鬆脫。確定 USB 纜線已穩固地連接至電腦及印表機背面的 USB 埠上。如果纜線連接穩固，請驗證是否已安裝印表機軟體。

錯誤訊息：相機在列印工作過程中斷開。

解決方案 列印工作將被取消。將 USB 纜線重新連接到相機和印表機，並重新傳送列印工作。

8 HP 支援中心

支援程序

如果您遇到問題，請執行下列步驟：

1. 檢查 HP Photosmart 隨附的說明文件。
2. 造訪 HP 線上支援網站：www.hp.com/support。所有的 HP 客戶都可獲得 HP 線上支援。線上支援是取得最新裝置資訊和專家協助的最快捷方式，其中包括：
 - 快速連絡合格的線上支援人員
 - HP Photosmart 的軟體與驅動程式更新程式
 - 實用的 HP Photosmart 資訊與常見問題疑難排解資訊
 - 註冊 HP Photosmart 後，即可自動取得該裝置的更新程式、支援通知及 HP 新聞簡訊
3. 僅適用於歐洲地區：請聯絡您購買產品的經銷商。如果 HP Photosmart 有硬體故障，可能會要求您將該裝置送回當地的經銷商處 (在裝置的有限保固期內，提供免費維修服務；保固期限過後，您需要支付維修費用)。
4. 致電 HP 支援中心。支援選項和可用性會因裝置、國家/地區和語言而異。

致電 HP 支援中心

如需支援電話號碼清單，請參閱封面內的電話號碼清單。

電話支援期限

北美洲、亞太地區及拉丁美洲 (包括墨西哥) 可獲得一年的電話支援。若要確定歐洲、中東及非洲的電話支援期限，請瀏覽 www.hp.com/support。您需支付標準電話費用。

致電

請使用電腦與 HP Photosmart 旁邊的電話致電 HP 支援中心。請準備好提供以下資訊：

- 裝置型號 (位於裝置正面的標籤上)
- 裝置序號 (位於裝置的背面或底部)
- 狀況發生時所顯示的訊息
- 下列問題的答案：
 - 之前是否發生過此狀況？
 - 您是否可以再現此狀況？
 - 問題發生前後，您是否在電腦上新增任何新硬體或軟體？
 - 在此問題出現之前是否發生過其他任何狀況 (如打雷、移動裝置等)？

電話支援期限過後

電話支援期限過後，HP 提供的支援服務將酌情收費。您也可以到 HP 線上支援網站取得說明：www.hp.com/support。請聯絡 HP 經銷商或致電您所在國家/地區的支援中心，以了解關於支援選項的詳細資訊。

A 規格

這一節列出安裝 HP Photosmart 軟體的最低系統需求，並提供此印表機的規格。
如需印表機規格及系統需求的完整清單，請參閱螢幕「HP Photosmart 印表機說明」。
如需檢視 HP Photosmart 螢幕說明的詳細資訊，請參閱[歡迎](#)。

系統需求

元件	Windows PC 最低需求	Macintosh 最低需求
作業系統	Microsoft® Windows 98、2000 Professional、ME、XP Home 與 XP Professional	Mac® OS X 10.3、10.4 及更新版本
處理器	Intel® Pentium® II (或同等級) 或更快的處理器	G3、G4、G5 或 Intel Core Duo 或更高版本
RAM	64 MB (建議 128 MB)	Mac OS X 10.3、10.4 及更新版本：128 MB
可用磁碟空間	500 MB	150 MB
視訊顯示器	800 x 600，16 位元或更高	800 x 600，16 位元或更高
CD-ROM 光碟機	4x	4x
連線	USB ：Microsoft Windows 98、2000 Professional、ME、XP Home 與 XP Professional PictBridge ：使用前方的相機連接埠 Bluetooth ：使用選購的 HP Bluetooth 無線轉接器	USB ：前方連接埠和後方連接埠 (Mac OS X 10.3、10.4 及更新版本) PictBridge ：使用前方的相機連接埠 Bluetooth ：使用選購的 HP Bluetooth 無線轉接器
瀏覽器	Microsoft Internet Explorer 5.5 或更新版本	—

印表機規格

類別	規格
連線	USB ：Microsoft Windows 98、2000 Professional、Me、XP Home 與 XP Professional；Mac OS X 10.3、10.4 及更新版本
影像檔案格式	JPEG 基準

(續)

類別	規格
	TIFF 24 位元 RGB 未壓縮的交換格式 TIFF 24 位元 YCbCr 未壓縮的交換格式 TIFF 24 位元 RGB 封包位元交換格式 TIFF 8 位元灰階未壓縮/封包位元 TIFF 8 位元調色盤彩色、未壓縮/封包位元 TIFF 1 位元未壓縮/封包位元/1D Huffman
視訊檔案格式	Motion-JPEG AVI Motion-JPEG QuickTime MPEG-1
材質規格	建議的最大長度：61 公分 (24 英吋) 建議的最大紙張厚度：292 微米 (千分之 11.5 英吋) 建議的最大信封厚度：673 微米 (千分之 26.5 英吋)
支援的材質尺寸	從電腦列印時的支援尺寸 7.6 x 12.7 公分到 22 x 61 公分 (3 x 5 英吋到 8.5 x 24 英吋) 從控制台列印時的支援尺寸 公制：A6、A4、10 x 15 公分 (含標籤或不含標籤)； 英制：3.5 x 5 英吋、4 x 6 英吋 (含標籤或不含標籤)，4 x 12 英吋、5 x 7 英吋、8 x 10 英吋、8.5 x 11 英吋；其他：Hagaki 和 L 尺寸
支援的材質類型	紙張 (一般紙張、噴墨紙、相紙以及全景相片) 信封 投影片 標籤紙 卡片：索引卡、賀卡、Hagaki 卡、A6 卡、L 尺寸卡 轉印紙 Avery C6611 和 C6612 相片貼紙：10 x 15 公分 (4 x 6 英吋)，每頁具有 16 張方形或橢圓形貼紙
記憶卡	CompactFlash I 和 II 型 Microdrive MultiMediaCard Secure Digital Memory Sticks xD-Picture Card
記憶卡支援的影像檔案格式	列印：請參閱此表格中的影像檔案格式部份。 儲存：所有檔案格式

(續)

類別	規格
紙匣 - 支援的材質尺寸	主紙匣 8 x 13 公分到 22 x 61 公分 (3 x 5 英吋到 8.5 x 24 英吋) 相片匣 最大 10 x 15 公分 (4 x 6 英吋)，含標籤或不含標籤 出紙匣 皆可支援主紙匣和相片匣尺寸
紙匣容量	主紙匣 100 張一般紙張 14 張信封 20 - 40 張卡片 (取決於卡片的厚度) 30 張標籤紙 25 張投影片、轉印紙或相紙 10 張相紙 相片匣 出紙匣 20 張相紙 50 張一般紙張 10 張卡片或信封 25 張標籤紙或轉印紙
作業環境	建議的溫度範圍： 攝氏 15-30 度 (華氏 59-86 度) 最大溫度範圍： 攝氏 5-40 度 (華氏 41-104 度) 儲存溫度範圍： 攝氏 -40-60 度 (華氏 -40-140 度) 建議的濕度範圍： 20-80% 相對濕度 最大濕度範圍： 10-80% 相對濕度
物理規格	高度： 17.9 公分 (6.8 英吋)。 寬度： 46.25 公分 (18.2 英吋) 深度： 38.7 公分 (15.25 英吋) 重量： 7.7 公斤 (17.0 磅)。
耗電量	列印，平均：75 W 列印，最大：94 W 閒置：13.3-16.6 W
電源供應器型號	HP 零件編號 0957-2105
電源要求	100 - 240 VAC (± 10%)、50 - 60 Hz (± 3 Hz)
墨匣	HP 黃色墨匣

(續)

類別	規格
	<p>HP 青藍色墨匣 HP 淡青藍色墨匣 HP 洋紅色墨匣 HP 淡洋紅色墨匣 HP 黑色墨匣</p> <p>附註 您可以在此印表機中使用的墨匣編號印在此印刷版指南的封底頁面上。如果您已多次使用此印表機，您應該也可以在印表機軟體中找到墨匣編號。如需詳細資訊，請參閱插入墨匣。</p>
列印速度 (最大)	<p>黑色列印輸出：每分鐘 32 頁 彩色列印輸出：每分鐘 31 頁 相片：每張 10 x 15 公分 (4 x 6 英吋) 相片 14 秒</p>
USB 支援	<p>Microsoft Windows 98、2000 Professional、ME、XP Home 與 XP Professional Mac OS X 10.3、10.4 及更新版本</p> <p>HP 建議使用長度不超過 3 公尺 (10 英呎) 的 USB 2.0 全速相容纜線。</p>

B HP 保固

HP 產品	保固期限
軟體媒體	90 天
印表機	1 年
列印或墨匣	直至 HP 油墨已耗盡或印在列印墨匣上的「保固結束日期」到期，視何者為先。本保固不包含經過重新填裝、再製、整修、使用不當，或擅自修改的 HP 墨匣產品。
配件	90 天

A. 有限保固範圍

1. Hewlett-Packard (HP) 向您 (最終使用者) 保證，自購買之日起到上述指定期限內，以上指定的 HP 產品無材料及製造的瑕疵；保固期限自客戶購買產品之日起生效。
2. 對於軟體產品，HP 的有限保固僅適用於無法執行其程式指令的狀況。HP 並不保證任何產品工作時都不會中斷或無誤。
3. HP 的有限保固僅涵蓋因正常使用產品而發生的瑕疵，而不適用於由其他情況發生的瑕疵，包括下列任何一種情況：
 - a. 不適當的維護或修改；
 - b. 使用非 HP 提供或支援的軟體、媒體、零件或耗材；
 - c. 違反產品規範的操作；
 - d. 未經授權的修改和誤用。
4. 對於 HP 印表機產品，使用非 HP 列印墨匣或重新填裝的列印墨匣不會影響對客戶的保固或任何 HP 與客戶之間的支援合約。然而，如果印表機因為使用非 HP 列印墨匣或重新填裝的列印墨匣出問題或受損，HP 會針對該項問題或損壞維修所耗的時間和材料，收取標準的費用。
5. 如果 HP 在有效的保固期限內，收到 HP 保固範圍內任何產品瑕疵的通知，HP 可以選擇修理或更換有瑕疵的產品。
6. 如果 HP 不能修理或更換在 HP 保固範圍內的有瑕疵產品，HP 將在接到通知後於合理的時間內，退還購買產品的全款。
7. 未收到客戶的瑕疵產品前，HP 沒有義務進行修理、更換或退款。
8. 更換品可能是新產品或者相當於新的產品，只要在功能性上至少相當於被更換的產品即可。
9. HP 產品可能包含性能上相當於新零件的再製零件、元件或材料。
10. HP 的有限保固，在任何具有 HP 產品經銷的國家/地區都有效。其他保固服務 (如現場實地服務) 合約，可與 HP 授權服務機構簽訂，這些機構分布在由 HP 或授權進口商銷售的 HP 產品的國家/地區。

B. 保固限制

在當地法律許可的範圍內，對於 HP 的產品，HP 及其協力廠商都不會明示或暗示地提供其他保證或任何條件，並對於產品適售性、品質滿意度以及針對特定用途的適用性之暗示保證或條件，特別不予擔保。

C. 責任限制

1. 在當地法律許可的範圍內，本保固聲明中提供的補償是客戶可獲得的唯一補償。
2. 在當地法律許可的範圍內，除了本保固聲明中明確提出的義務之外，不論是否基於合約、侵權、或其他法律理論，也不論是否已告知損害的可能性，HP 及其協力廠商都不會對直接、間接、特殊、意外或者因果性的傷害負責。

D. 當地法律

1. 本保固聲明賦予客戶特定的法律權利。客戶也可能有其他權利，這種權利在美國因州而異，在加拿大因省而異，在世界各地則因國家或地區而異。
2. 若本保固聲明與當地法律不一致，以當地法律為準。在此情況下，本保固聲明的某些免責和限制條款可能不適用於客戶。例如，美國的某些州以及美國以外的某些政府 (包括加拿大的某些省)，可能會：
 - a. 排除本保固聲明中的無擔保聲明和限制條款，以免限制客戶的法定權利 (例如英國)；
 - b. 限制製造商實施這些免責或限制條款的能力；或者
 - c. 賦予客戶其他保固權利，指定製造商不能聲明免責的暗示保固期限，或者不允許對暗示的保固期限進行限制。
3. 除了法律許可的範圍外，本保固聲明中的條款，不得排除、限制或修改對客戶銷售 HP 產品的強制性法定權利，而是對這些權利的補充。

索引

- B**
 - Bluetooth
 - 功能選項設定 11
 - 連接到印表機 23, 33
 - 無線印表機轉接器 11
 - C**
 - CompactFlash 20
 - D**
 - DPOF 24
 - E**
 - Energy Star 2
 - H**
 - Hewlett-Packard 公司通告 2
 - HP Instant Share 33
 - HP Photosmart Essential 37
 - HP Photosmart Premier 37
 - HP Photosmart Studio (僅供 Mac 使用) 38
 - HP Photosmart 共享 35, 38
 - HP 直接列印數位相機 25
 - HP 軟體更新程式 44
 - I**
 - iPod 34
 - J**
 - JPEG 檔案格式 20
 - M**
 - Macintosh
 - HP Photosmart Mac 軟體 38
 - Memory Sticks 20
 - Microdrive 20
 - MPEG-1 檔案格式 20
 - MultiMediaCard 20
 - P**
 - Photosmart 共享. 參閱
 - HP Photosmart 共享
 - PictBridge 相機 25
 - S**
 - Secure Digital 20
 - Sony Memory Stick. 參閱
 - Memory Sticks
 - T**
 - TIFF 檔案格式 20
 - U**
 - USB
 - 規格 63
 - 連接埠 8
 - 連線類型 33
 - X**
 - xD-Picture 卡 20
 - 四畫**
 - 支援 61
 - 支援期限過後 62
 - 支援程序 61
 - 日期與時間戳記 29
 - 六畫**
 - 列印
 - 不連接電腦 23
 - 相片 23
 - 相片範圍 23
 - 從 BlueTooth 裝置 23
 - 從 PictBridge 相機 23
 - 從相機 25
 - 從記憶卡 23
 - 從電腦 37
 - 測試頁 43
 - 列印品質
 - 更改 23
 - 列印頭
 - 故障 56
 - 停止 55
 - 清潔 42
 - 印表機
 - 首頁 11
 - 配件 11
 - 清潔 41
 - 規格 63
 - 連接 23, 33
 - 七畫**
 - 找不到墨匣 54
 - 更換墨匣 19
 - 系統需求 63
 - 八畫**
 - 取出記憶卡 22
 - 取得協助 47
 - 放入紙張 15
 - 法規注意事項
 - 法規機型識別號碼 2
 - 版面及相片尺寸 27
 - 九畫**
 - 品質
 - 列印測試頁 43
 - 相片 28
 - 相紙 45
 - 按鈕 10
 - 相片
 - 支援的檔案格式 20
 - 日期與時間戳記 29
 - 列印 23
 - 透過電子郵件傳送 35
 - 提高品質 28
 - 著古董色 29
 - 裁剪 29
 - 增加外框 29
 - 褐色色調 29
 - 儲存到電腦 33
 - 縮放 29
 - 相機
 - PictBridge 25
 - 列印來源 25
 - 直接列印 25
 - 連接到印表機 23, 33
- 愛護與維護** 41
 - 零件 8
 - 說明文件 7
 - 錯誤訊息 51
 - 儲存 45
- 印表機軟體
 - 更新 44
- 印表機軟體, 更新 37
- 色彩效果 29

- 連接埠 8
- 致電 61
- 致電 HP 支援中心 61
- 首頁, 畫面 11
- 十畫**
- 校正, 需要 55
- 校正印表機 41
- 校正頁 41
- 紙匣, 紙張 8
- 紙張
 - 放入 15
 - 紙匣 8
 - 規格 63
 - 維護 15, 45
 - 購買和選擇 15
- 能源消耗 2
- 記憶卡
 - 支援類型 20
 - 列印來源 23
 - 取出 22
 - 將相片儲存到電腦 35
 - 插入 21
- 配件 11
- 配件, 雙面列印 11
- 十一畫**
- 問題與解答 47
- 將相片儲存到電腦 33
- 常見問題集 47
- 控制台 10
- 清潔
 - 列印頭 42
 - 印表機 41
 - 銅色接點 42
- 規格 63
- 十二畫**
- 插入
 - 記憶卡 21
 - 墨匣 19
- 測試頁 43
- 無邊框列印 29
- 著古董色 29
- 視訊片段
 - 支援的檔案格式 20
- 十三畫**
- 愛護與維護 41
- 損壞, 墨匣 54
- 運送印表機 11
- 電子郵件相片 35

- 電腦
 - 列印來源 37
 - 系統需求 63
 - 將相片儲存到 35
 - 連接到印表機 33
- 電話支援 61
- 電話支援期限
 - 支援期限 61
- 十四畫**
- 疑難排解
 - 錯誤訊息 51
- 說明 47
- 說明文件, 印表機 7
- 十五畫**
- 數位列印順序格式 24
- 數位相機. 參閱 相機範圍
- 列印 23
- 褐色色調 29
- 墨水
 - 空 54
 - 儘快更換 53
 - 檢查存量 43
- 墨水存量, 檢查 19
- 墨匣
 - HP 墨水已經耗盡 55
 - 不正確 53
 - 印表機校正 55
 - 找不到 54
 - 更換 19
 - 空 54
 - 非 HP 墨水 55
 - 插入 19
 - 測試 43
 - 損壞 54
 - 過期 54
 - 墨水存量, 檢查 19
 - 儘快更換 53
 - 儲存 45
- 十六畫**
- 燈號 10
- 錯誤訊息 51
- 十七畫**
- 儲存
 - 印表機 45
 - 相紙 45
 - 墨匣 45
- 檔案格式, 支援的 20

檔案格式, 支援的 63

十八畫
雙面列印 11

HP Photosmart D7100 series User Guide

English



Copyrights and trademarks

© 2006 Hewlett-Packard Development Company, L.P.

The information contained herein is subject to change without notice.

Reproduction, adaptation, or translation without prior written permission is prohibited, except as allowed under the copyright laws.

Hewlett-Packard Company notices

The information contained in this document is subject to change without notice.

All rights reserved. Reproduction, adaptation, or translation of this material is prohibited without prior written permission of Hewlett-Packard, except as allowed under copyright laws.

The only warranties for HP products and services are set forth in the express warranty statements accompanying such products and services. Nothing herein should be construed as constituting an additional warranty. HP shall not be liable for technical or editorial errors or omissions contained herein.

Trademarks

HP, the HP logo, and Photosmart are property of Hewlett-Packard Development Company, L.P.

The Secure Digital logo is a trademark of the SD Association.

Microsoft and Windows are registered trademarks of Microsoft Corporation.

CompactFlash, CF, and the CF logo are trademarks of the CompactFlash Association (CFA).

Memory Stick, Memory Stick Duo, Memory Stick PRO, and Memory Stick PRO Duo are trademarks or registered trademarks of Sony Corporation.

MultiMediaCard is a trademark of Infineon Technologies AG of Germany, and is licensed to the MMCA (MultiMediaCard Association).

Microdrive is a trademark of Hitachi Global Storage Technologies.

xD-Picture Card is a trademark of Fuji Photo Film Co., Ltd., Toshiba Corporation, and Olympus Optical Co., Ltd.

Mac, the Mac logo, and Macintosh are registered trademarks of Apple Computer, Inc.

iPod is a trademark of Apple Computer, Inc.

Bluetooth is a trademark owned by its proprietor and used by Hewlett-Packard Company under license.

PictBridge and the PictBridge logo are trademarks of the Camera & Imaging Products Association (CIPA).

Other brands and their products are trademarks or registered trademarks of their respective holders.

Regulatory model identification number

For regulatory identification purposes, your product is assigned a Regulatory Model Number. The Regulatory Model Number for your product is VCVRA-0603. This regulatory number should not be confused with the marketing name (HP Photosmart D7100 series, etc.) or product numbers (Q7046A, etc.).

Energy consumption - Energy Star®

Hewlett-Packard Company is committed to providing quality products in an environmentally sound manner. For information about the HP's environmental product stewardship program see the onscreen help.

Contents

1	Welcome	7
	Special features.....	7
	Accessing the onscreen HP Photosmart printer help.....	7
	Printer parts.....	8
	Optional accessories.....	11
	Printer menu.....	11
	View & Print.....	12
	Save.....	12
	Share.....	12
	Settings.....	12
2	Get ready to print	15
	Load paper.....	15
	Choose the right paper.....	15
	Paper loading tips.....	15
	Load the main tray.....	15
	Load the photo tray.....	16
	Insert ink cartridges.....	17
	Purchasing replacement ink cartridges.....	17
	Ink cartridge tips.....	18
	Ink cartridge warranty information.....	18
	Inserting or replacing the ink cartridges.....	19
	Insert memory cards.....	20
	Supported file formats.....	20
	Inserting a memory card.....	21
	Memory card types.....	21
	Removing a memory card.....	22
3	Printing photos without a computer	23
	Printing photos.....	23
	Print photos from a memory card.....	23
	Print one or more photos.....	23
	Print all photos on the memory card.....	23
	Print camera-selected photos from a memory card.....	24
	Print using the Wizard.....	24
	Print photos from video clips.....	24
	Print a photo index.....	25
	Stop printing.....	25
	Print photos from a digital camera.....	25
	Digital camera with Bluetooth wireless technology.....	25
	Digital camera with PictBridge technology.....	26
	Print photos from an iPod.....	26
	Photo layouts.....	26
	Improving photo quality.....	28
	Adjust photos with poor brightness.....	28
	Remove red eye from photos.....	28
	Adjust poor-quality video clips.....	28

Getting creative.....	29
Add a color effect.....	29
Add the date and time to your prints.....	29
Change the print quality.....	29
Crop a photo.....	30
Print panoramic photos.....	30
4 Getting connected.....	31
Connecting to other devices.....	31
Saving photos to a computer.....	33
Connecting through HP Photosmart Share.....	33
5 Printing from a computer.....	35
Using creative options in the printer software.....	35
HP Photosmart Premier (Windows users).....	35
HP Photosmart Essential (Windows users).....	35
HP Photosmart Studio (Macintosh Users).....	36
HP Photosmart Share.....	36
Set print preferences.....	36
Open the electronic help.....	37
HP Real Life technologies features.....	37
6 Care and maintenance.....	39
Clean and maintain the printer.....	39
Clean the outside of the printer.....	39
Aligning the printer.....	39
Print a sample page.....	39
Automatically clean the printhead.....	40
Manually clean the ink cartridge contacts.....	40
Print a self test report.....	41
Update the software.....	42
Store and transport the printer and ink cartridges.....	43
Store and transport the printer.....	43
Store and transport the ink cartridges.....	43
Maintain the quality of photo paper.....	43
7 Troubleshooting.....	45
Printer hardware problems.....	45
Printing problems.....	46
Error messages.....	50
Paper errors.....	50
Ink cartridge errors.....	52
Memory card errors.....	55
Computer and connectivity printing errors.....	58
8 HP support.....	59
Support process.....	59
HP support by phone.....	59
Phone support period.....	59
Placing a call.....	59
After the phone support period.....	60
A Specifications.....	61
System requirements.....	61
Printer specifications.....	61
B HP Warranty.....	65

Index.....67

1 Welcome

Thank you for purchasing an HP Photosmart D7100 series printer! With this new photo printer you can print beautiful photos, save photos to a computer, and create fun and easy projects with or without a computer.

This guide primarily explains how to print without connecting a computer. To learn how to print from a computer, install the printer software and view the electronic Help. For an overview of using a computer and the printer together, see [Printing from a computer](#). For information about installing the software, see the *Quick Start* guide.

Home users can learn how to:

- Print borderless photos from the printer or from a computer
- Choose a photo layout
- Convert a color photo to black and white, or apply a color effect such as Sepia or Antique

The printer comes with the following documentation:

- **Quick Start Guide:** The *Quick Start Guide* explains how to set up the printer, install the printer software, and print your first photo.
- **User Guide:** The *User Guide* is the book you are reading. This guide describes the basic features of the printer, explains how to use the printer without connecting a computer, and contains hardware troubleshooting information.
- **Onscreen help:** The onscreen HP Photosmart printer help describes how to use the printer with a computer and contains software troubleshooting information.

Special features

New features and media make it easier than ever to produce high-quality photos:

- When you use the new HP Advanced Photo Paper (also called HP Photo Paper in some countries/regions), special sensors in the printer detect a mark on the back of the paper and automatically select the optimal print settings. For more information about this new paper, see [Choose the right paper](#).
- HP Real Life technologies make it easy for you to get better photos. Automatic red eye removal and adaptive lighting to enhance detail in shadows are just a few of the many technologies included. You can explore the many editing and enhancing options from both the control panel and from the printer software. To access these features from the control panel, see [Improving photo quality](#). To learn how to find them in the software, see [HP Real Life technologies features](#).

Accessing the onscreen HP Photosmart printer help

After you have installed the HP Photosmart printer software on a computer, you can view the onscreen HP Photosmart printer help:

- **Windows PC:** From the **Start** menu, select **Programs** (in Windows XP, select **All Programs**) > **HP** > **HP Photosmart D7100 series** > **Photosmart Help**.
- **Macintosh:** From the Finder **Help** menu, choose **Mac Help**. From the Help Viewer **Library** menu, choose **HP Photosmart Mac Help**.

Printer parts

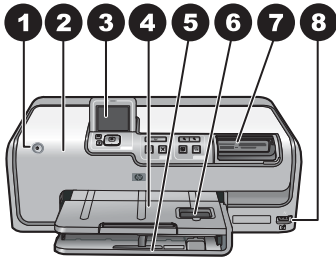

Front of printer

1	On: Press this button to turn on the printer.
2	Top cover: Lift this cover to access the ink cartridges and to clear paper jams. To lift the cover, grasp the top cover below the HP logo and pull upward.
3	Printer Screen: Use this screen to view photos, menus, and messages.
4	Output tray: Use this tray to catch your printouts. Lift this tray to access the photo tray.
5	Main tray: Pull out this tray and load paper, transparencies, envelopes, or other media with the side to be printed facing down.
6	Photo tray: Lift the output tray, pull out this tray, and load small-size paper up to 10 x 15 cm (4 x 6 inch) into the photo tray for printing with the side to be printed facing down. The paper may be tabbed or untabbed.
7	Memory card slots: Insert memory cards here. For a list of supported memory cards, see Insert memory cards .
8	Camera port: Connect a PictBridge™ digital camera, the optional HP Bluetooth® wireless printer adapter, or an iPod.

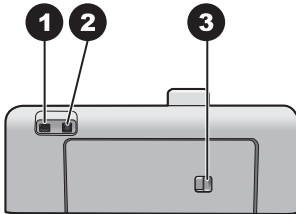

Back of printer

1	Power cord connection: Use this port to connect the power cord included with the printer.
2	USB port: Use this port to connect the printer to a computer.
3	Rear access door: Remove this door to clear paper jams or to install the optional HP Automatic Two-sided Printing Accessory. See Optional accessories .

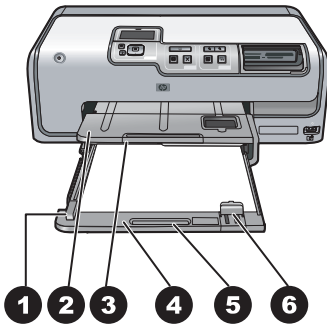

Main and Output trays

1	Paper-width guide: Adjust this guide to fit close to the edge of the paper in the main tray.
2	Output tray: Use this tray to catch your printouts. Lift this tray to access the photo tray.
3	Output tray extender: Pull towards you to extend the output tray to catch your printouts.
4	Main tray: Pull out this tray and load plain paper, transparencies, envelopes, or other media with the side to be printed facing down.
5	Main tray grip: Pull toward you to extend the Main tray.
6	Paper-length guide: Adjust this guide to fit close to the end of the paper in the main tray.

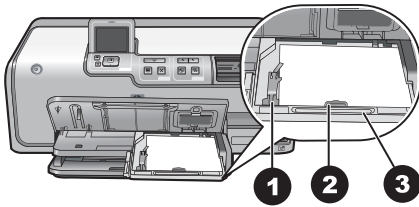
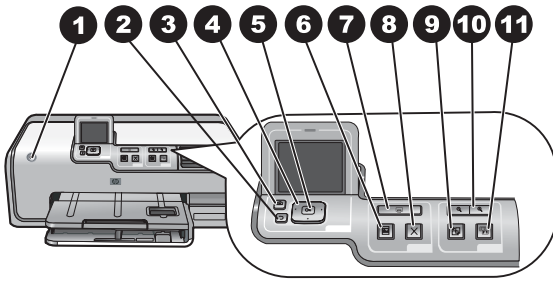

Photo tray

1	Paper-width guide: Adjust this guide to fit close to the edge of the paper in the photo tray.
2	Paper-length guide: Adjust this guide to fit close to the end of the paper in the photo tray.
3	Photo tray grip: Pull toward you to extend the photo tray.



Control panel

1	On: Turn on the printer or put it into power save mode.
2	Back: Step back one screen at a time.
3	Home: Press to return to the home screen.
4	Navigation arrows: Adjust the crop box, navigate menu choices, and control the playback of a video clip.
5	OK: Select a highlighted item, menu or dialog choice, and play/pause a video clip during playback.
6	Print Preview: View a preview of the selected photo or photos.
7	Print: Print the selected photos from the inserted memory card, or from a camera connected to the front camera port.
8	Cancel: Stops a print job.
9	Rotate: Rotate a photo or a crop box.
10	Zoom (+)(-): Zoom in or out of a photo or crop box. You can also press Zoom (-) to view photos four at a time when viewing a photo at normal magnification.
11	Photo Fix: Automatically enhances and applies lighting, contrast, focus and red eye removal features to all printed photos.

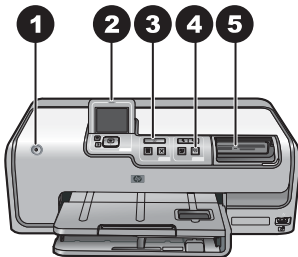

Indicator lights

1	On light: Solid blue if the printer is on, otherwise it is off.
2	Attention light: Flashes when there is an error condition. See the printer screen for instructions or information about the error. For more information, see The Attention light is on.
3	Print light: Solid blue when the printer is on and ready to print, flashes blue when the printer is printing or busy with self-maintenance.
4	Photo Fix light: Solid blue when the Photo Fix function is turned on.
5	Memory Card light: Solid blue if a memory card is inserted, flashes if the printer is accessing a memory card, off if no memory card is inserted or if more than one card is inserted. See the printer screen for instructions.

Optional accessories

There are several optional accessories available for the printer that enhance its portability for printing anywhere, anytime. The appearance of the accessories may vary from what is shown.

To purchase supplies, go to:

- www.hpshopping.com (U.S.)
- www.hp.com/go/supplies (Europe)
- www.hp.com/jp/supply_inkjet (Japan)
- www.hp.com/paper (Asia/Pacific)

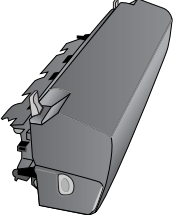
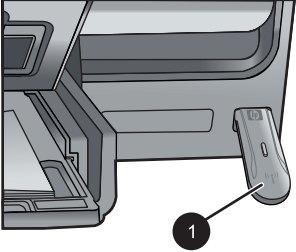
Accessory name	Description		
 <p data-bbox="224 743 607 798">HP Automatic Two-sided Printing Accessory</p>	<p data-bbox="690 499 1136 703">This accessory automatically flips each page to print on both sides. You will save money (two-sided printing reduces paper consumption) and time (no need to remove the paper and reinsert it to print on the back), plus you will make bulky documents more manageable.</p> <p data-bbox="690 715 1136 772">This accessory may not be available in all countries/regions.</p>		
 <p data-bbox="224 1102 577 1159">HP Bluetooth® wireless printer adapter</p> <table border="1" data-bbox="224 1171 667 1223"> <tr> <td data-bbox="224 1171 270 1223">1</td> <td data-bbox="270 1171 667 1223">Insert the Bluetooth adapter into the front camera port</td> </tr> </table>	1	Insert the Bluetooth adapter into the front camera port	<p data-bbox="690 824 1136 1027">The HP Bluetooth® wireless printer adapter goes into the camera port on the front of the printer. This adapter lets you use Bluetooth wireless technology for printing from many Bluetooth-enabled devices, including digital cameras, camera phones, and PDAs.</p> <p data-bbox="690 1038 1136 1119">For more information on printing with this accessory, go to www.hp.com/go/bluetooth.</p>
1	Insert the Bluetooth adapter into the front camera port		

Printer menu

Press the home button to access the home screen. You can access all of the functions from the home screen as well as setup menus.

View & Print

Wizard: Use the wizard to guide you through the printing process. Also use the wizard to improve photo quality and apply advanced photo effects such as brightness and color effects.

4×6: Use to print 4×6 inch (10 × 15 cm) photographs.

Enlargement: Use Enlargement to print different photo sizes.

Print All: Select to print all the photos from the memory card inserted in the printer.

Other Print Projects: Use Other Projects to print panoramic, HP CD/DVD Tattoos, wallet prints, and passport photos.

- **Panorama Prints:** Select to turn panoramic printing **On** or **Off** (default). Select **On** to print all selected photos with a 3:1 aspect ratio; load 10 x 30 cm (4 x 12 inch) paper before printing.
- **HP CD/DVD Tattoos:** Select to print labels for CD/DVDs.
- **Wallet Prints:** Use to print wallet-sized photos.
- **Passport Photos:** Select to print a passport photo.

Save

Select **Save** to save selected images to a connected PC.

Share

Use **Share** to select and share photos through HP Photosmart Share.

Settings

- **Tools:** Use tools to display the ink gauge, adjust the print quality, print a sample page, print a test page, and to clean and align cartridges.
 - Display Ink Gauge: Use to enable an ink supply gauge on the home screen.
 - **Print sample page:** Select to print a sample page, which is useful for checking the print quality of the printer. This feature is not available in all printer models.
 - **Print test page:** Select to print a test page containing information about the printer that can help in troubleshooting problems.
 - **Clean Printhead:** Select to clean the print head when white lines or streaks appear in your printouts. After the cleaning finishes, the printer prints a self test report. You have the option to clean the print head again if the report shows print quality problems.
 - **Align printer:** Select to align the printer when white lines or streaks appear in your printouts.
- **Bluetooth**
 - **Device address:** Some devices with Bluetooth wireless technology require you to enter the address of the device they are trying to locate. This menu option shows the printer address.
 - **Device name:** You can select a name for the printer that appears on other devices with Bluetooth wireless technology when they locate the printer.
 - **Passkey:** When the Bluetooth **Security level** of the printer is set to **High**, you must enter a passkey to make the printer available to other Bluetooth devices. The default passkey is 0000.
 - **Visibility:** Select **Visible to all** (default) or **Not visible**. When **Visibility** is set to **Not visible**, only devices that know the printer address can print to it.

- **Security level:** Select **Low** (default) or **High**. The **Low** setting does not require users of other devices with Bluetooth wireless technology to enter the printer passkey. **High** requires users of other devices with Bluetooth wireless technology to enter the printer passkey.
- **Reset Bluetooth options:** Select to reset all items in the Bluetooth menu to their default values.
- **Help Menu:** Use the help menu for instructions about using the printer.
 - **Cartridges:** Select to see an animation of how to install an ink cartridge.
 - **Main Tray Loading:** Select to read main tray paper loading instructions.
 - **Photo Tray Loading:** Select to read photo tray paper loading instructions.
 - **Paper jams:** Select to see an animation of how to clear a paper jam.
 - **Camera connect:** Select to read instructions on how to connect a PictBridge camera to the printer.
- **Preferences**
 - 4 × 6 print paper size: Choose **Ask before print** to select the paper type and size each time you print (default).
 - **Print quality:** Choose either **Best** (default) or **Normal** print quality.
 - **Paper Type:** Select **Automatic** (default) and the printer automatically detects the paper type and size.
 - **Date Stamp:** Use this option to include the date and/or time on your printed photos.
 - **Colorspace:** Choose a colorspace. The Auto-select default tells the printer to use the Adobe RGB colorspace, if available. The printer defaults to sRGB if Adobe RGB is not available.
 - **PictBridge Tray Select:** Use to select the default paper tray for printing through the PictBridge connection.
 - **Video enhancement:** Select **On** (default) or **Off**. When you select **On**, the quality of photos printed from video clips is improved.
 - **Restore Factory Defaults:** Restores factory settings for all menu items except **Select language** and **Select country/region** (under **Language** in **Preference** menu) and Bluetooth settings (under **Bluetooth** in the main printer menu). This setting does not affect HP Instant Share or Network defaults.

2 Get ready to print

This section includes the following topics:

- [Load paper](#)
- [Insert ink cartridges](#)
- [Insert memory cards](#)

Load paper

Learn how to choose the right paper for your print job and how to load it into the input tray for printing.

Choose the right paper

Use HP Advanced Photo Paper. It is especially designed to work with the inks in your printer to create beautiful photos.

For a list of available HP-designed photo paper, or to purchase supplies, go to:

- www.hpshopping.com (U.S.)
- www.hp.com/eur/hpoptions (Europe)
- www.hp.com/jp/supply_inkjet (Japan)
- www.hp.com/paper (Asia/Pacific)

The printer is set by default to print the best quality photos on HP Advanced Photo Paper. If you print on a different type of paper, be sure to change the paper type from the printer menu. See [Printer menu](#).

Paper loading tips

Paper loading tips:

- Load paper with the side to be printed facing down.
- You can print photos and documents on a wide variety of paper sizes, from 8 x 13 cm (3 x 5 inch) up to 22 x 61 cm (8.5 x 24 inch). The 10 x 15 cm (4 x 6 inch) photo paper is available with and without tabs.
- Before loading paper, pull the out main paper tray and slide out the paper-width and paper-length guides to make room for the paper. After loading paper, adjust the guides to fit close to the edges of the paper without bending the paper. When finished loading paper, push the main tray back in all the way.
- Load only one type and size of paper at a time in the same tray.
- After loading paper, extend the output tray extension and raise the backstop to catch your printed pages.

Load the main tray

Any supported photo or plain paper media

1. Extend the main tray.
2. Slide the paper-width and paper-length guides to their outermost positions.
3. Load paper with the side to be printed facing down. Make sure the stack of paper fits loosely under the tab on the paper-length guide.

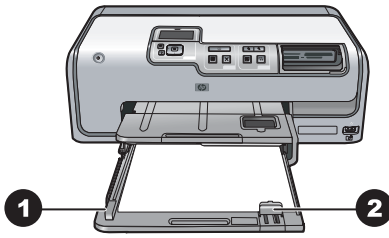

- 1 Paper-width guide
- 2 Paper-length guide

4. Adjust the paper-width and paper-length guides inward until they stop at the edges of the paper.
5. Push the main tray all the way in.

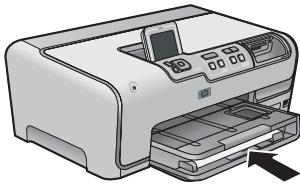

- 1 Push in the main tray all the way

Load the photo tray

Use photo paper up to 10 x 15 cm (4 x 6 inch) with or without tabs, Hagaki cards, A6 cards, and L-size cards.

1. Lift the output tray and extend the photo tray.
2. Adjust the paper-width and paper-length guides outward to make room for the paper.

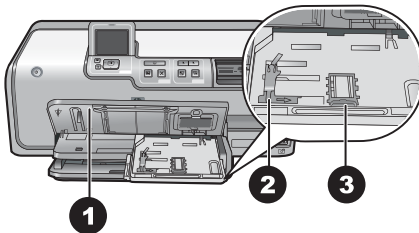

- 1 Output tray
- 2 Paper-width guide
- 3 Paper-length guide

3. Load up to 20 sheets of paper into the photo tray with the print side down. If you are using tabbed paper, insert the paper so the tab is closer to you.
4. Adjust the paper-width and paper-length guides inward until they stop at the edges of the paper. Make sure the stack of paper fits loosely under the tab on the paper-length guide.
5. Push in the photo tray.
6. Close the output tray.

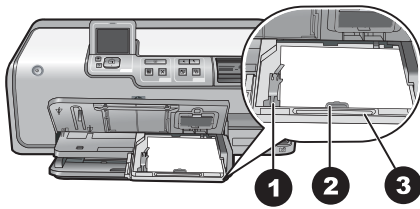

1	Paper-width guide
2	Paper-length guide
3	Photo tray grip.

Insert ink cartridges

The first time you set up and use your HP Photosmart printer, make sure to install the ink cartridges that were shipped with your printer. The ink in these ink cartridges is specially formulated to mix with the ink in the print head assembly.

Purchasing replacement ink cartridges

When purchasing replacement cartridges, refer to the cartridge numbers that appear on the back cover of this guide. These cartridge numbers may vary by country/region.



Note If you have already used the printer several times and you have installed the HP Photosmart printer software, you can also find the cartridge numbers in the printer software. **Windows users:** Right-click the HP Digital Imaging Monitor icon in the Windows taskbar, and select **Launch/Show HP Solution Center**. Select **Settings**, then **Print Settings**, and then **Printer Toolbox**. Click the **Estimated Ink Levels** tab, and then click **Ink Cartridge Information**. To order ink cartridges, click **Shop Online**. **Mac users:** Click **HP Photosmart Studio** in the Dock. In the HP Photosmart Studio toolbar, click **Devices**. From the **Information and Settings** pop-up menu, choose **Maintain Printer** and then click **Launch Utility**. In the **Configuration Settings** list, click **Supply Info**.

Ink cartridge tips

HP Vivera Inks deliver true-to-life photo quality and exceptional fade resistance resulting in vivid colors that last for generations! HP Vivera Inks are specially-formulated and scientifically tested for quality, purity and fade resistance.

For best print quality, HP recommends that you install all retail ink cartridges before the install-by date stamped on the box.

For optimum printing results, HP recommends using only genuine HP ink cartridges. Genuine HP ink cartridges are designed and tested with HP printers to help you easily produce great results, time after time.



Note HP cannot guarantee the quality or reliability of non-HP ink. Printer service or repairs required as a result of printer failure or damage attributable to the use of non-HP ink will not be covered under warranty.

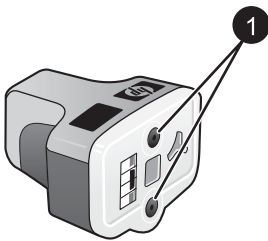

Ink cartridge

1 Do not insert objects into these holes



Caution To prevent ink loss or spillage: leave the ink cartridges installed while transporting the printer, and avoid leaving used ink cartridge(s) out of the printer for extended lengths of time.

Ink cartridge warranty information

The HP ink cartridge(s) warranty is applicable when the product is used in its designated HP printing device. This warranty does not cover HP ink products that have been refilled, remanufactured, refurbished, misused, or tampered with.

During the warranty period the product is covered as long as the HP ink is not depleted and the end of warranty date has not been reached. The end of warranty date, in YYYY/MM/DD format, may be found on the product as indicated:

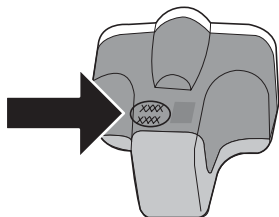

For a copy of the HP Limited Warranty Statement, see [HP Warranty](#).

Inserting or replacing the ink cartridges

1. Make sure the power is on, then lift the top cover. Make sure all packing material has been removed from inside the printer.

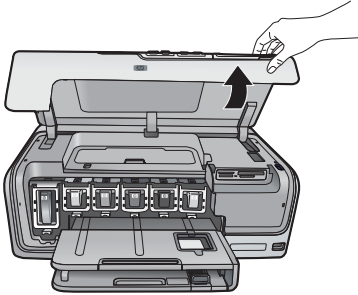

2. Squeeze the gray tab below an ink cartridge slot to release the gray latch inside the printer, then lift the latch.

The ink cartridge areas are color-coded for easy reference. Lift the latch below the appropriate color to insert or replace a cartridge. From left to right, the ink cartridges are black, yellow, light cyan, cyan, light magenta, and magenta.

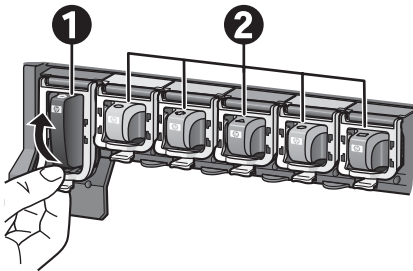

- | | |
|---|---|
| 1 | Ink cartridge latch for the black ink cartridge |
| 2 | Ink cartridge area for the color ink cartridges |

3. If you are replacing a cartridge, remove the old cartridge by pulling it toward you out of its slot.

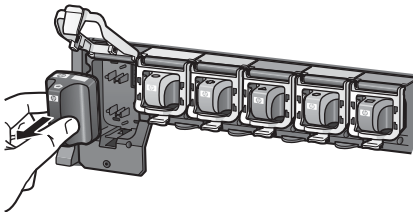

Recycle the old cartridge. The HP Inkjet Supplies Recycling Program is available in many countries/regions and lets you recycle used ink cartridges free of charge. For more information, go to www.hp.com/hpinfo/globalcitizenship/environment/recycle/inkjet.html.

4. Remove the new ink cartridge from its packaging, and while holding it by the handle, slide the ink cartridge into the empty slot.

Make sure you insert the ink cartridge into the slot that has the same shaped icon and color as the new cartridge. The copper-colored contacts should be facing the printer as the ink cartridge is inserted.



Note The first time you set up and use the printer, make sure to install the ink cartridges that were shipped with your printer. The ink in these ink cartridges is specially formulated to mix with the ink in the print head assembly.

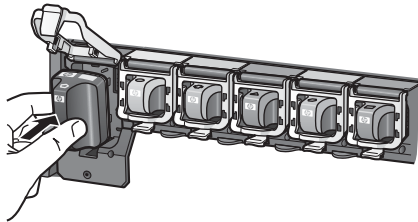

5. Press down on the gray latch until it clicks into place.

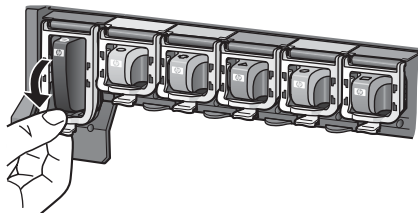

6. Repeat steps 2 through 5 for each ink cartridge you are replacing. You must install all six cartridges. The printer will not work if an ink cartridge is missing.
7. Close the top cover.

Insert memory cards

After you have taken pictures with a digital camera, you can remove the memory card from the camera and insert it into the printer to view and print your photos. The printer can read the following types of memory cards: CompactFlash™, Memory Sticks, Microdrive™, MultiMediaCard™, Secure Digital™, and xD-Picture Card™.



Caution Using any other type of memory card may damage the memory card and the printer.

To learn about other ways of transferring photos from a digital camera to the printer, see [Connecting to other devices](#).

Supported file formats

The printer can recognize and print the following file formats directly from a memory card: JPEG, uncompressed TIFF, Motion JPEG AVI, Motion-JPEG QuickTime, and MPEG-1. If your digital camera saves photos and video clips in other file formats, save the files to your computer and print them using a software program. For more information, see the electronic Help.

Inserting a memory card

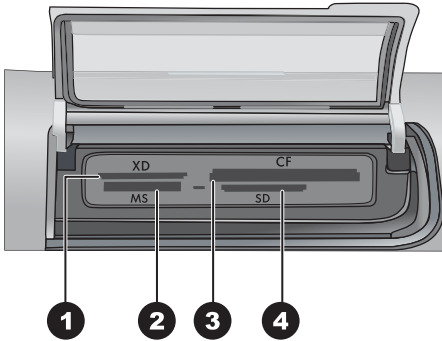

Memory card slots

1	xD-Picture Card
2	Memory Stick
3	Compact Flash I and II, Microdrive
4	Secure Digital, MultiMediaCard (MMC)

Memory card types

Find your memory card in the following table and use the instructions to insert the card into the printer.

Guidelines:





- Insert only one memory card at a time.
- Gently push the memory card into the printer until it stops. The memory card slot allows for only a portion of the card to insert into the printer; do not try to force the memory card all the way into the printer.
- When the memory card is inserted correctly, the memory card light flashes and then remains solid green.

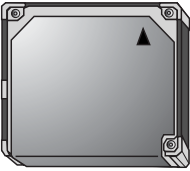

Caution 1 Inserting the memory card any other way may damage the card and the printer.

Caution 2 Do not pull out a memory card while the memory card light is flashing green. For more information, see [Removing a memory card](#).

Memory card	How to insert the memory card
CompactFlash 	<ul style="list-style-type: none">• Front label faces up, and if the label has an arrow, the arrow points toward the printer• Edge with metal pinholes goes into the printer first

Memory card	How to insert the memory card
<p data-bbox="114 170 287 196">Memory Stick</p>  A vertical, rectangular Memory Stick card with a small white triangle pointing upwards at the top left corner.	<ul data-bbox="413 175 1156 314" style="list-style-type: none">• Angled corner is on the left• Metal contacts face down• If you are using a Memory Stick Duo or Memory Stick PRO Duo card, attach the adapter that came with the card before you insert the card into the printer
<p data-bbox="114 447 249 473">Microdrive</p>  A square Microdrive card with a small white triangle pointing upwards at the top right corner and metal pinholes along the bottom edge.	<ul data-bbox="413 447 1156 531" style="list-style-type: none">• Front label faces up, and if the label has an arrow, the arrow points toward the printer• Edge with metal pinholes goes into the printer first
<p data-bbox="114 678 306 704">MultiMediaCard</p>  A rectangular MultiMediaCard with a small white triangle pointing upwards at the top left corner.	<ul data-bbox="413 678 766 730" style="list-style-type: none">• Angled corner is on the right• Metal contacts face down
<p data-bbox="114 878 287 904">Secure Digital</p>  A rectangular Secure Digital card with a small white triangle pointing upwards at the top left corner.	<ul data-bbox="413 878 766 930" style="list-style-type: none">• Angled corner is on the right• Metal contacts face down
<p data-bbox="114 1078 309 1104">xD-Picture Card</p>  A rectangular xD-Picture Card with a small white triangle pointing upwards at the top left corner and a white label at the bottom.	<ul data-bbox="413 1078 866 1130" style="list-style-type: none">• Curved side of card points toward you• Metal contacts face down

Removing a memory card

Wait until the Memory Card light stops flashing, then gently pull the memory card to remove it from the printer.



Caution Do not pull out a memory card while the Memory Card light is flashing. A flashing light means that the printer is accessing the memory card. Removing a memory card while it is being accessed may damage the printer and the memory card or corrupt the information on the memory card.

3 Printing photos without a computer

The HP Photosmart D7100 series printer lets you select, enhance, and print photos without even turning on the computer. Once you've set up the printer using the instructions in the *Quick Start Guide*, you can insert a memory card in the printer and print your photos using the buttons on the printer control panel.

You can also print photos directly from a digital camera. For more information, see [Print photos from a digital camera](#).

Printing photos

You can print photos without a computer in several different ways:

- Insert a memory card with photos on it into one of the memory card slots on the printer
- Connect a PictBridge digital camera to the camera port on the front of the printer
- Install the optional HP Bluetooth® wireless printer adapter and print from a digital camera with Bluetooth wireless technology

Print photos from a memory card

You can print photos from a memory card by inserting the card into the printer and using the printer control panel to view, select, enhance, and print photos. You can also print camera-selected photos—photos you marked for printing using a digital camera—directly from a memory card.

Printing from a memory card is quick and easy, and does not drain the digital camera batteries.

Print one or more photos

Before you begin, make sure that the memory card is inserted in the printer and the paper tray you want to use is loaded with the correct paper.

1. Select **View & Print**, then press **OK**.
2. Select **4×6** or **Enlargement** to select your desired photo size, then press **OK**.
3. Select your desired paper size, then press **OK**.
4. Select a layout then press **OK**.
5. Using the arrow keys, scroll through the available photos.
6. Press **OK** to select one or more images.
 - Press **Zoom** - to view up to 9 images on the printer screen.
 - Press the up arrow to increase the number of prints for the selected image.
7. Press **Print** to print the selected photographs.

Check the Photo tray light to verify that the correct tray is selected — the light should be off for the Main tray and on for the Photo tray.

Print all photos on the memory card

Before you begin, make sure that the memory card is inserted in the printer and the paper tray with the paper you want to use is loaded with the correct paper.

1. Select **View & Print**, then press **OK**.
2. Select **Print All**.
3. Select the desired paper size and press **OK**.
→ Select a layout and press **OK**.
4. Select **Print Now** and press **OK**.

Print camera-selected photos from a memory card

When you select photos for printing using a digital camera, the camera creates a Digital Print Order Format (DPOF) file that identifies the selected photos. The printer can read DPOF 1.0 and 1.1 files directly from a memory card.

1. Use the digital camera to select the photos you want to print. For more information, see the documentation that came with the camera.
2. If you select **default** as the photo layout with the camera, select **Layout** to select a photo layout.
If you select a photo layout other than **default** with the camera, photos print in the camera-selected layout regardless of the printer setting.
3. Load the desired paper.
4. Remove the memory card from the digital camera and insert it into the printer.
5. When a message appears on the printer screen asking if you want to print the camera-selected photos, press **OK**.

The photos you selected with the camera begin printing.

If the printer cannot find or read all of the camera-selected photos on the card, it prints the photos that it can read.

After printing, the printer deletes the DPOF file and unmarks the photos.

Print using the Wizard

The print wizard provides detailed instructions about selecting, sizing, editing, and printing photographs.



Note Use the wizard to improve photo quality and apply advance effects such as brightness and color effects.

1. Select **View & Print** and press **OK**.
2. Select **Wizard** and press **OK**.
3. Follow the prompts to print your desired photo or photos.

Print photos from video clips

You can view video clips on the printer screen, and select and print individual frames.

When you first insert a memory card containing a video clip, the printer uses the first frame of the video clip to represent the clip on the printer screen.

The printer recognizes video clips recorded in these formats:

- Motion-JPEG AVI
- Motion-JPEG QuickTime
- MPEG-1

The printer ignores video clips in any other format.

Before you begin, make sure that the memory card is inserted in the printer and the paper tray you want to use is loaded with the correct paper.

1. Select **View & Print** and press **OK**.
2. To select your desired photo size, select **4×6** or **Enlargement** then press **OK**.
3. Select your desired paper size and press **OK**.
4. Scroll to select the available videos using the left and right arrows.



Note Videos display a video camera icon in the center of the image.

5. Press the up arrow to play the video.
6. To select a frame to print, press the up arrow to pause the video. The video must be paused to select frames for printing.
7. Press **OK** to select the desired frame for printing.
8. Press **Print** to print the selected frames.

Print a photo index

A photo index shows thumbnail views and index numbers for up to 2000 photos on a memory card. Use plain paper instead of photo paper to reduce costs.

A photo index may be several pages long.

Before you begin, make sure that the memory card is inserted in the printer and the paper tray you want to use is loaded with the correct paper.

1. Select **View & Print** and press **OK**.
2. Select **Print All** and press **OK**.
3. Select 8.5×11 paper.
4. Select the index sheet icon (16 images per page) and press **OK**.

Stop printing

To stop a print job in progress, press **Cancel**.

Print photos from a digital camera

You can print photos by connecting a PictBridge digital camera directly to the camera port of the printer with a USB cable. If you have a digital camera with Bluetooth wireless technology, you can insert the optional HP Bluetooth® wireless printer adapter in the printer and send photos to the printer wirelessly.

When you print from a digital camera, the printer uses the settings that you selected on the camera. For more information, see the documentation that came with the camera.

Digital camera with Bluetooth wireless technology

If you have a digital camera with Bluetooth wireless technology, you can purchase the optional HP Bluetooth® wireless printer adapter and print from a camera using a Bluetooth wireless connection.



Note You can also print from other devices with Bluetooth wireless technology, such as PDAs and camera phones. For more information, see [Connecting to other devices](#) and the documentation that came with your Bluetooth adapter.

1. Set the Bluetooth options for the printer using the Bluetooth menu on the display. For more information, see [Settings](#).
2. Load printer paper.
3. Insert the HP Bluetooth® wireless printer adapter into the camera port on the **front** of the printer.
The light on the adapter flashes when the adapter is ready to receive data.
4. Follow the instructions in the documentation that came with the digital camera to send photos to the printer.

Digital camera with PictBridge technology

1. Turn on the PictBridge digital camera and select the photos you want to print.
2. Load paper.
3. Make sure the camera is in PictBridge mode, then connect it to the camera port on the **front** of the printer using the USB cable that came with the camera.
Once the printer recognizes the PictBridge camera, the selected photos print automatically.

Print photos from an iPod

If you have an iPod that can store photos, you can connect your iPod to the printer and print the photos.

Before you begin

Check that the images you copy to the iPod are in JPEG format.



Note iPods might not be available in your country/region.

To import photos to an iPod



1. Copy photos from a memory card to your iPod using the Belkin Media Reader for iPod.
2. Verify that photos are on your iPod by selecting **Photo Import** on the iPod menu. Photos appear as **Rolls**.

To print photos from an iPod

1. Connect the iPod to the camera port on the **front** of the printer using the USB cable that came with the iPod. The printer screen displays **Reading Device** for several minutes while the photos are read. Then the photos appear on the printer screen.
2. Select the photo(s) you want to print and press **Print**. For more information on selecting and printing photos, see [Printing photos](#).

Photo layouts

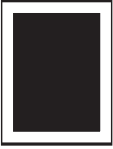
Select the desired print function from the View & Print menu and press **OK**, choose your desired print function, then select your desired paper size to select a layout.

Layout	Paper size (photo size)
<p>1 per page borderless</p> 	<p>4 x 6 inch (4 x 6 inch) 10 x 15 cm (10 x 15 cm) 5 x 7 inch (5 x 7 inch) 8.5 x 11 inch (8.5 x 11 inch)</p>
<p>1 per page</p> 	<p>3.5 x 5 inch (3.25 x 4.75 inch) 4 x 6 inch (3.75 x 5.75 inch) 10 x 15 cm (9.53 x 14.6 cm) 5 x 7 inch (4.75 x 6.75 inch) 8 x 10 inch (7.75 x 9.75 inch) 8.5 x 11 inch (8 x 10 inch) A6 (9.86 x 14.16 cm) A4 (20 x 25 cm) Hagaki (9.36 x 14.16 cm) L (8.25 x 12.06 cm)</p>
<p>2 per page</p> 	<p>3.5 x 5 inch (2.25 x 3.25 inch) 4 x 6 inch (2.75 x 3.75 inch) 5 x 7 inch (3.25 x 4.75 inch) 8 x 10 inch (4.75 x 6.5 inch) 8.5 x 11 inch (5 x 7 inch) A6 (6.92 x 9.86 cm) A4 (13 x 18 cm) Hagaki (6.8 x 9.36 cm) L (5.87 x 8.25 cm)</p>
<p>3 per page</p> 	<p>3.5 x 5 inch (1.5 x 2.25 inch) 4 x 6 inch (1.75 x 2.625 inch) 5 x 7 inch (2.25 x 3.375 inch) 8 x 10 inch (3.33 x 5 inch) 8.5 x 11 inch (4 x 6 inch) A6 (4.77 x 7.15 cm) A4 (10 x 15 cm) Hagaki (4.52 x 6.78 cm) L (3.96 x 5.94 cm)</p>
<p>4 per page</p>	<p>3.5 x 5 inch (1.5 x 2.25 inch) 4 x 6 inch (1.75 x 2.5 inch) 5 x 7 inch (2.2 x 3.25 inch)</p>

(continued)

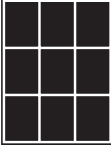
Layout	Paper size (photo size)
	8 x 10 inch (3.5 x 4.75 inch) 8.5 x 11 inch (3.5 x 5 inch) A6 (4.77 x 6.92 cm) A4 (9 x 13 cm) Hagaki (4.52 x 6.5 cm) L (3.96 x 5.7 cm)
9 per page 	3.5 x 5 inch (1 x 1.375 inch) 4 x 6 inch (1.125 x 1.5 inch) 5 x 7 inch (1.5 x 2 inch) 8 x 10 inch (2.25 x 3 inch) 8.5 x 11 inch (2.5 x 3.25 inch) – Wallet size A6 (3.07 x 4.05 cm) A4 (6.4 x 8.4 cm) Hagaki (2.9 x 3.86 cm) L (2.53 x 3.36 cm)



Note The printer may rotate the photos to fit the layout.

Improving photo quality

The printer provides a variety of enhancements that can improve the quality of a photo printed from a memory card. These print settings do not change the original photo. They only affect printing.

Adjust photos with poor brightness

1. Select **View & Print** and press **OK**.
2. Select **Wizard** and press **OK**.
3. Follow the onscreen instructions to select your paper size and photo, then press **OK** to view the menu.
4. Select **Edit Photo** and press **OK**.
5. Select **Photo Brightness** and press **OK**.
6. Press **◀** and **▶** to increase or decrease the photo brightness to the desired level, then press **OK**.

Remove red eye from photos

The automatic red eye removal feature is enabled when you turn on the Photo fix function. Enabling the Photo Fix function applies Smart Focus, Adaptive Lighting, and red eye removal features to selected photos.

→ Press **Photo Fix** to enable the Photo Fix function.

Adjust poor-quality video clips

This preference affects photos printed from video clips.

Improve the quality of photos printed from video clips

1. Select **Settings** and press **OK**.
2. Using the arrow keys, find and select **Preferences** and press **OK**.
3. Using the arrow keys, find and select **Video Enhancement** and press **OK**.
4. Select **On**, then press **OK**.

For information about printing photos from video clips, see [Print photos from a memory card](#).

Getting creative

The printer provides a variety of tools and effects that let you use your photos in creative ways. These print settings do not change the original photo. They only affect printing.

Add a color effect

You can set the printer to change the color option applied to a photo from **Color** (default) to **Black & white**, **Sepia**, or **Antique**.

Photos printed in **Sepia** print in brown tones and look similar to photos produced in the early 1900s. Photos printed in **Antique** print in the same brown tones, but with some pale colors added to give the appearance that the photos are hand-colored.

1. Select **View & Print** and press **OK**.
2. Select **Wizard** and press **OK**.
3. Follow the onscreen instructions to select your paper size and photo, then press **OK**.
4. Select **Done Selecting** and press **OK**.
5. Select **Edit Photo** and press **OK**.
6. Select **Color Effect** and press **OK**.
7. Select the desired color effect and press **OK**.

Add the date and time to your prints

You can print a stamp on the front of your photos that shows when the photo was taken. This preference affects all prints.

1. Select **Settings** and press **OK**.
2. Using the arrow keys, find and select **Preferences** and press **OK**.
3. Select **Date Stamp** and press **OK**.
4. Select one of the following date/time stamp options:
 - **Date and Time**
 - **Date Only**
 - **Off**

If you use a computer to modify the photo and then save your changes, the original date and time information are lost. Changes that you make to the photo using the printer control panel do not affect the date and time information.

Change the print quality

You can change the print quality for photos. Best quality is the default and produces the highest quality photos. Normal quality conserves ink and prints faster.

To change the print quality:

1. Select **Settings** and press **OK**.
2. Select **Preferences** and press **OK**.
3. Select **Print quality** and press **OK**.
4. Select the desired print quality and press **OK**.

Print quality will revert to Best after the next print job.

Crop a photo

Press **Zoom +** and **Zoom –** to increase or decrease the magnification by 1.25×. The maximum level is 5.0×.

1. Select **View & Print** and press **OK**.
2. Select **4×6** or **Enlargement** to select your desired photo size and press **OK**.
3. Select the desired paper size and press **OK**.
4. Select the desired photo and press **OK**.
5. Press **Zoom +** to increase the magnification of the photo by 1.25×. The green crop box appears. Press **Zoom +** repeatedly until you reach the desired magnification. (After zooming in, you can zoom back out by pressing **Zoom –**.)



Note The crop box changes from green to yellow if printing at the selected magnification will noticeably reduce the print quality.

6. At any magnification level, press the arrows to move the crop box left, right, up, or down.
7. Press **OK** when the portion of the image you want to print is in the crop box. Cropping does not change the original photo. It only affects printing.

Print panoramic photos

1. Select **View & Print** and press **OK**.
2. Select **Other Projects** and press **OK**.
3. Select **Panorama Prints** and press **OK**.
4. Follow the prompt to load 10 x 30 cm (4 x 12 inch) media, then press **OK**.
5. Select a photo and press **OK**. If desired, crop the photo before printing. The crop box has a 3:1 aspect ratio.





Note All photos printed in panoramic mode are printed borderless.

4 Getting connected

Use the printer to stay connected to other devices and people.

Connecting to other devices

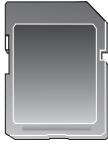
This printer offers several ways of connecting to computers or other devices. Each connection type lets you do different things.

Connection type and what you need	This lets you...
<p>Memory cards</p>  <p>A memory card</p> <p>A compatible digital camera memory card Insert the memory card into the appropriate memory card slot on the front of the printer.</p>	<ul style="list-style-type: none">• Print directly from a memory card to the printer.• Save photos from a memory card inserted in the printer to a computer where you can enhance or organize them in the HP Photosmart Premier or other software. For more information, see Saving photos to a computer and Print photos from a memory card.
<p>USB</p> <ul style="list-style-type: none">• A Universal Serial Bus (USB) 2.0 full-speed compliant cable 3 meters (10 feet) or less in length. For instructions about connecting the printer with a USB cable, see the <i>Quick Start</i> booklet.• A computer with Internet access (to use HP Photosmart Share).	<ul style="list-style-type: none">• Print from a computer to the printer. See Printing from a computer.• Save photos from a memory card inserted in the printer to a computer where you can enhance or organize them in the HP Photosmart Premier or other software.• Share photos through HP Photosmart Share.• Print directly from an HP Photosmart direct-printing digital camera to the printer. For more information, see Print photos from a digital camera and the camera documentation.
<p>PictBridge</p>  <p>The PictBridge symbol</p>	<p>Print directly from a PictBridge-compatible digital camera to the printer.</p> <p>For more information, see Print photos from a digital camera and the camera documentation.</p>

(continued)

Connection type and what you need	This lets you...
<p>A PictBridge-compatible digital camera and a USB cable.</p> <p>Connect the camera to the camera port on the front of the printer.</p>	
<p>Bluetooth</p> <p>The optional HP Bluetooth wireless printer adapter.</p> <p>If the printer came with this accessory or you have purchased it separately, see the accompanying documentation and the onscreen Help for instructions.</p>	<p>Print from any device with Bluetooth wireless technology—such as a digital camera, a camera phone, or a PDA—to the printer.</p> <p>If you connect the optional HP Bluetooth wireless printer adapter to the printer through the camera port, be sure to set the Bluetooth printer menu options as needed. See Settings.</p>
<p>iPod</p> <p>An iPod and the USB cable that came with it. Connect the iPod to the camera port on the front of the printer.</p>	<p>Print directly from an iPod (with photos stored in it) to the printer. For more information, see Print photos from an iPod.</p>

Saving photos to a computer

You can save photos to a computer from any memory card inserted in the printer, if you set up a USB connection between the two devices.

If you are using a Windows computer

Use either of these methods to save photos to your computer.

- Insert a memory card into the printer. The HP Photosmart Premier transfer software (HP Transfer and Quick Print) opens on your computer screen and allows you to designate a location on the computer to save images. For more information, see the onscreen HP Photosmart printer software help.
- Insert a memory card into the printer. The memory card appears in Windows Explorer as a removable drive. Open the removable drive and drag photos from the card to any location on your computer.

If you are using a Macintosh

1. Insert a memory card into the printer.
2. Wait for iPhoto to start and read the contents of the memory card.



Note iPhoto starts only if it is set as the default application.

3. Click **Import** to save the photos on the card to your Macintosh.



Note The memory card also appears on the desktop as a drive icon. You can open it and drag photos from the card to any location on your Macintosh.

Connecting through HP Photosmart Share

Use HP Photosmart Share to share photos with friends and relatives using e-mail, online albums, or an online photo finishing service. Your printer must be connected through a USB cable to a computer with Internet access and have all the HP software installed. If you try to use Share and do not have all the required software installed or configured, a message prompts you through the required steps.

Use Share (USB) to send photos (Windows users):

1. Insert a memory card and select some photos.
2. Select **Share** on the printer screen and press **OK**.
3. Follow the instructions on your computer to share the selected photos with others.

Use Share (USB) to send photos (Mac users)

1. Open **HP Photosmart Studio** and select photos to share. For information about HP Photosmart Studio, see [HP Photosmart Premier \(Windows users\)](#).
2. In the HP Photosmart Studio toolbar, click **Share**.
3. Click **Continue**, and follow the instructions on your computer to share the selected photos with others.

See the onscreen software help for more information about using HP Photosmart Share

5 Printing from a computer

To print from a computer, the printer software must be installed. During software installation, either HP Photosmart Premier (Windows Full-install users), HP Photosmart Essential (Windows Express-install users) or the HP Photosmart Studio (Mac) is installed on your computer, allowing you to organize, share, edit, and print photos.

For more information on installing the software, see the *Quick Start Guide*. Update the software regularly to ensure you have the latest features and improvements; for instructions, see [Update the software](#).

To work with photos, you need to transfer them to a computer that is connected to the printer. See [Saving photos to a computer](#).



Note Windows users: HP Photosmart Premier can only be used on computers with processors that have Intel® Pentium® III (or equivalent) and higher.

Using creative options in the printer software

Read through these tips on how to open and use HP Photosmart Premier, HP Photosmart Essential, HP Photosmart Studio (Mac), and HP Photosmart Share.

HP Photosmart Premier (Windows users)

HP Photosmart Premier is an easy-to-use software program that gives you everything you need to have fun with your photos, in addition to basic photo editing and printing. This software also gives you access to HP Photosmart Share so that you can easily share your photos.

Open HP Photosmart Premier

→ Double-click the **HP Photosmart Premier** icon on your desktop. If you need help, see the software help within HP Photosmart Premier.

Explore the many features of HP Photosmart Premier:

- **View** — View photos in multiple sizes and ways. Easily organize and manage your photos.
- **Edit** — Crop your photos and fix photos with red eye. Automatically adjust and enhance your photos in different sizes and in multiple layouts.
- **Print** — Print your photos in different sizes and in multiple layouts.
- **Share** — Send photos to family and friends without the bulky attachments using HP Photosmart Share, a better way to send e-mail.
- **Create** — Easily create album pages, cards, calendars, panoramic photos, CD labels, and more.
- **Back-up** — Make back-up copies of your photos to store and save.

HP Photosmart Essential (Windows users)

HP Photosmart Essential is an easy-to-use software program that gives you basic photo editing and printing capabilities. This software also gives you access to HP Photosmart Share so that you can easily share your photos. HP Photosmart Essential is only available for Windows users.

Open HP Photosmart Essential

- Double-click the **HP Photosmart Essential** icon on your desktop. If you need help, see the software help within HP Photosmart Essential.

Explore the many features of HP Photosmart Essential:

- **View** — View photos in multiple sizes and ways. Easily organize and manage your photos.
- **Edit** — Crop your photos and fix photos with red eye. Automatically adjust and enhance your photos to make them perfect.
- **Print** — Print your photos in different sizes and in multiple layouts.
- **Share** — Send photos to family and friends without the bulky attachments with HP Photosmart Share, a better way to send e-mail.

HP Photosmart Studio (Macintosh Users)

- Click the **HP Photosmart Studio** icon in the Dock.

Explore the many features of the HP Photosmart Mac software that is accessible from the HP Photosmart Studio:

- **Import** — Import photos or videos from an HP digital camera.
- **View and Manage** — View, organize, and manage your photos and videos.
- **Edit** — Adjust and enhance your images.
- **Slideshow** — Create an online slideshow of your photos.
- **Panorama** — Create a single panoramic image from several images.
- **Create** — Create album pages, cards, labels, posters, banners, and more.
- **Print** — Print your photos and frames from video in standard sizes or in index sheet format.
- **Share** — Send photos to family and friends without the bulky attachments.
- **Shop** — Order online prints and gifts.

HP Photosmart Share

HP Photosmart Share allows you to send photos to family and friends without bulky e-mail attachments. For more information, see [Connecting through HP Photosmart Share](#) and the HP Photosmart Premier or HP Photosmart Essential help.

Open HP Photosmart Share (Windows users)

- Click the **HP Photosmart Share** tab within HP Photosmart Premier or HP Photosmart Essential.

Open HP Photosmart Share (Mac users)

- Click the **Applications** tab in HP Photosmart Premier, then double-click **HP Photosmart Share**.

Set print preferences

Print preferences are set by default, but can be altered to suit your needs. You can set specific job settings when you print from the computer. When you change settings before printing, the changes only affect the current print job. In some Windows software programs, you need to click **Properties** or **Preferences** within the **Print** dialog box to access the advanced printing features. See the electronic Help for more information about printing preferences.

Access print preferences (Windows users)

1. Open the **Print** dialog box, usually by selecting **Print** from the **File** menu.
2. Change the printing preferences in the **Print** dialog box tabs, or click **Properties** or **Preferences** to access more printing preferences.

Access print preferences (Mac users)

1. Open the **Print** dialog box, usually by selecting **Print** from the **File** menu.
2. Change the printing preferences in the **Print** dialog box by selecting the print options you want to change in the **Copies & Pages** drop-down menu.

For more information on changing the printing preferences, see the electronic Help.

Open the electronic help

Windows users:

- Press F1 on your keyboard.
- For field-level help, click the ? in the top right corner of the **Print** dialog box.

Mac users:

1. From the **Finder**, choose **Help > Mac Help**.
2. Choose **HP Photosmart Mac Help** from the **Library** menu, and then choose the printer name in the **HP Photosmart Mac Help** table of contents.

HP Real Life technologies features

Explore the many photo editing and enhancing options in the HP Real Life technologies software features. These features—such as automatic red eye removal and adaptive lighting—make it easy for you to print high-quality photos.

There are three options available:

- The **Basic** setting sharpens images and improves the quality and clarity of low resolution images, such as those downloaded from the Internet.
- The **Full** setting improves images that are under exposed or over exposed, contain dark areas or red eye, or have colors that appear washed out.
- The **Off** setting lets you edit the image manually in a software program such as HP Photosmart software.

Access Real Life technologies features (Windows users)

1. Open the **Print** dialog box, usually by selecting **Print** from the **File** menu.
2. Click the **Paper/Quality** tab, then click the **Real Life Digital Photography** button —OR— Click the **Properties** or **Preferences** button, and then click the **Real Life Digital Photography** button.

Access Real Life technologies features (Mac users)

1. Open the **Print** dialog box, usually by selecting **Print** from the **File** menu.
2. Select **Real Life Digital Photography** from the **Copies & Pages** drop-down menu.

6 Care and maintenance

The printer requires very little maintenance. Follow the guidelines in this section to extend the life span of the printer and printing supplies, and to ensure that the photos you print are always of the highest quality.

- [Clean and maintain the printer](#)
- [Update the software](#)
- [Store and transport the printer and ink cartridges](#)
- [Maintain the quality of photo paper](#)

Clean and maintain the printer

Keep the printer and print cartridge clean and well maintained using the simple procedures in this section.

Clean the outside of the printer

1. Turn off the printer, then disconnect the power cord from the back of the printer.
2. Wipe the outside of the printer with a soft cloth that has been lightly moistened with water.



Caution Do not use any type of cleaning solution. Household cleaners and detergents may damage the printer finish. Do not clean the interior of the printer. Keep all fluids away from the interior. Do not lubricate the metal rod on which the print head slides. Noise is normal when the print head moves back and forth.

Aligning the printer

Use the following procedure when the self test report shows streaking or white lines through any of the blocks of color.

If you still have print quality problems after aligning the printer, try cleaning the print head using the procedure described in [Care and maintenance](#). If print quality problems persist after aligning and cleaning, contact HP Support.

1. Load letter or A4 unused plain white paper into the Main tray.
2. Select **Settings** and press **OK**.
3. Select **Tools** and press **OK**.
4. Scroll to find then select **Align printer**.
The printer aligns the print head, prints an alignment page, and calibrates the printer. Recycle or discard the alignment page.
5. Press **OK**.

Print a sample page

You can print a sample page to test the printer photo printing quality and to make sure the paper is loaded correctly.

1. Load paper in the Main tray. Use plain paper to conserve photo paper.
2. Select **Settings** and press **OK**.
3. Select **Tools** and press **OK**.
4. Select **Print sample page** and press **OK**.

Automatically clean the printhead

If you notice white lines or streaks on the photos you print, or in the color blocks of the self test report, use this procedure to clean the print head. Do not clean the print head unnecessarily, as this wastes ink and shortens the life of the ink nozzles on the print head.

1. Load paper in the Main tray. Use plain paper to conserve photo paper.
2. Select **Settings** and press **OK**.
3. Select **Tools** and press **OK**.
4. Select **Clean printhead** and press **OK**.

If print quality still seems poor after you clean the print head, try aligning the printer using the procedure described in [Aligning the printer](#). If print quality problems persist after cleaning and aligning, contact HP support.

Manually clean the ink cartridge contacts

Clean the copper-colored ink cartridge contacts if a message appears on the printer screen that says a cartridge is missing or damaged.

Before cleaning the ink cartridge contacts, remove the ink cartridge and verify that nothing is covering the ink cartridge contacts or the ink cartridge slot, then reinstall the ink cartridge. If you continue to get a message that says a cartridge is missing or damaged, clean the ink cartridge contacts. If you still get this message after cleaning the contacts, you will need a replacement ink cartridge. Remove the affected ink cartridge and look at the end-of-warranty date on the bottom, in YYYY/MMM/DD format. If it is before the end-of-warranty date, contact HP support to obtain a replacement ink cartridge.

To clean the ink cartridge contacts:

1. Gather the following items to clean the contacts:
 - Distilled, filtered, or bottled water (tap water may contain contaminants that can damage the ink cartridge)



Caution Do not use platen cleaners or alcohol to clean the ink cartridge contacts. These can damage the ink cartridge or the HP Photosmart printer.

- Dry foam rubber swabs, lint-free cloth, or any soft material that will not come apart or leave fibers.
2. Open the top cover of the printer.
 3. Squeeze the gray tab below an ink cartridge slot to release the gray latch inside the printer, then lift the latch.



Caution Do not remove multiple ink cartridges at the same time. Remove and clean each ink cartridge one at a time. Do not leave the ink cartridge outside the printer for more than 30 minutes.

4. Lightly moisten a swab or cloth with water and squeeze out any excess water.
5. Hold the ink cartridge by its handle and gently wipe only the copper-colored contacts with the swab or cloth.

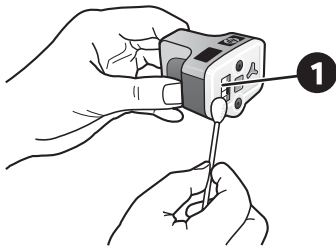

1 Gently wipe only the copper-colored contacts

6. Place the ink cartridge back into the empty slot and press down on the gray latch until it clicks into place.
7. Repeat if necessary for the other ink cartridges.
8. Close the top cover.



Caution The ink supply may become pressurized. Inserting a foreign object into the ink supply could result in ink being expelled and coming in contact with persons or property.

Print a self test report

If you are experiencing problems with printing, print a self test report. This two-page report—labelled the Extended Self Test Diagnostic Page—can help you diagnose printing problems and can provide valuable information if you need to call HP Support. You can also use this report to check on the approximate percentage of ink remaining in the ink cartridges.

1. Select **Settings** and press **OK**.
2. Select **Tools** and press **OK**, then scroll to Print test page.
3. Select **Print test page** and press **OK**.

The HP Photosmart printer prints a two-page self test report that contains the following information:

- **Product information:** Includes the model number, serial number, and other product information.
- **Revision information:** Includes the firmware version number and indicates whether or not you have an HP two-sided printing accessory (duplexer) installed.
- **Ink delivery system information:** Displays the approximate ink level of each installed ink cartridge, the status of each ink cartridge, the date each cartridge was installed, and the expiration date for each cartridge.
- **Print head assembly information:** Contains information that may be used for diagnostic purposes if you need to call HP Support.
- **Print head parameters:** Contains information that may be used for diagnostic purposes if you need to call HP Support.
- **Print quality pattern:** Displays six color blocks, representing each of the six installed cartridges. When streaks appear through the color blocks, or there are missing color blocks, clean the print head using the procedure described in [Care and maintenance](#). If the color blocks still show print quality problems after cleaning the print head, align the printer using the procedure described in [Aligning the printer](#). If the color blocks continue to show print quality problems after cleaning and aligning, contact HP support.
- **History log:** Contains information that may be used for diagnostic purposes if you need to call HP Support.

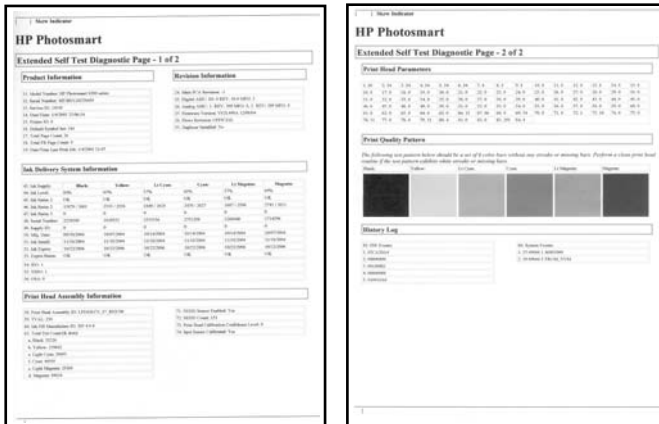

Self test report

Update the software

Download the latest printer software update periodically to ensure you have the latest features and improvements. You can download printer software updates by going to www.hp.com/support or by using HP Software Update.



Note The printer software update that you download from the HP Web site does not update the HP Photosmart Premier software.

Downloading the software (Windows)



Note Make sure you are connected to the Internet before you use HP Software Update.

1. From the Windows **Start** menu, select **Programs** (in Windows XP, select **All Programs**) > **Hewlett-Packard** > **HP Software Update**. The HP Software Update window opens.
2. Click **Check Now**. HP Software Update searches the HP Web site for printer software updates. If the computer does not have the most recent version of the printer software installed, a software update appears in the HP Software Update window.



Note If the computer has the most recent version of the printer software installed, the following message appears in the HP Software Update window: “No updates are available for your system at this time”.

3. If a software update is available, click the checkbox next to the software update to select it.
4. Click **Install**.
5. Follow the onscreen instructions to complete the installation.

Downloading the software (Mac)



Note Make sure you are connected to the Internet before you use HP Photosmart Updater.

1. On your Mac in the Finder, choose **Go > Applications**.
2. Choose **Hewlett-Packard > Photosmart > HP Photosmart Updater**.
3. Follow the onscreen instructions to check for software updates.
If you are behind a firewall, you need to enter the proxy server information in the updater.

Store and transport the printer and ink cartridges

Protect the printer and ink cartridges by storing them properly when you are not using them.

Store and transport the printer

The printer is built to withstand long or short periods of inactivity. Store the printer indoors out of direct sunlight in a place without temperature extremes.



Caution To prevent ink loss or spillage: do not transport or store the printer on its side, and leave the ink cartridges installed while storing and transporting the printer.

Store and transport the ink cartridges

When you transport or store the printer, always leave the active ink cartridge inside the printer to prevent the ink from drying out.



Caution 1 To prevent ink loss or spillage: leave the ink cartridges installed while storing and transporting the printer, and avoid leaving used ink cartridge(s) out of the printer for extended lengths of time.

Caution 2 Make sure the printer completes its power-down cycle before you unplug the power cord. This allows the printer to store the print head properly.

Follow this tip to help maintain your HP ink cartridges and ensure consistent print quality: Keep all unused ink cartridges in their original sealed packages until they are needed. Store ink cartridges at room temperature (15-35 °C or 59-95 °F).

Maintain the quality of photo paper

For best results with photo paper, follow the guidelines in this section.

To store photo paper

- Store the photo paper in its original packaging or in a resealable plastic bag.
- Store the packaged photo paper on a flat, cool, and dry surface.
- Return unused photo paper to the plastic bag. Paper left in the printer or exposed to the elements may curl.

To handle photo paper

- Always hold photo paper by the edges to avoid fingerprints.
- If the photo paper has curled edges, place it in its plastic storage bag and gently bend it in the opposite direction of the curl until the paper lies flat.

7 Troubleshooting

The HP Photosmart printer is designed to be reliable and easy to use. This chapter answers frequently asked questions about using the printer and printing without a computer. It contains information about the following topics:

- [Printer hardware problems](#)
- [Printing problems](#)
- [Error messages](#)

For additional troubleshooting information, see:

- **Software installation troubleshooting:** The *Quick Start* guide that came with the printer.
- **Printer software and printing from a computer troubleshooting:** The onscreen HP Photosmart Printer Help. For information about viewing the onscreen HP Photosmart Printer Help, see [Welcome](#).

Printer hardware problems

Before contacting HP support, read this section for troubleshooting tips or go to the online support services at www.hp.com/support.



Note If you want to connect the printer to a computer with a USB cable, HP recommends using a 2.0 high-speed compliant cable 3 meters (10 feet) or less in length.

The Print light is flashing blue but the printer is not printing

Solution The printer is busy processing information; wait for it to finish.

The Attention light is on

Solution

- Check the printer screen for instructions. If a digital camera is connected to the printer, check the camera screen for instructions. If the printer is connected to a computer, check the computer monitor for instructions.
- Turn off the printer, then unplug its power cord. Wait about 10 seconds, then plug it in again. Turn on the printer.

If the Attention light stays on after trying the above solutions, go to www.hp.com/support, or contact HP Support for help.

The printer does not find the photos I stored on my memory card

Solution The memory card may contain file types the printer cannot read directly from the card.

- Save the photos to a computer, then print them from the computer. For more information, see the onscreen HP Photosmart printer help and the documentation that came with the camera.
- The next time you take photos, set the digital camera to save them in a file format the printer can read directly from the memory card. For a list of supported file formats, see [Printer specifications](#). For instructions on setting the digital camera to save photos in specific file formats, see the documentation that came with the camera.

The memory card may need to be reformatted if the problem persists.

The printer is plugged in but will not turn on

Solution

- The printer may have drawn too much power. Unplug the printer power cord. Wait about 10 seconds, then plug the cord back in. Turn on the printer.
 - The printer may be plugged into a power strip that is turned off. Turn on the power strip, then turn on the printer.
 - The power cord could be defective. Make sure the green light on the power cord is lit.
-

The printer makes noises when I turn it on, or starts making noises after sitting unused for a while

Solution The printer may make noises after long periods of inactivity (approximately 2 weeks) or when its power supply has been interrupted and then restored. This is normal operation. The printer is performing an automatic maintenance procedure to ensure it produces the best quality output.

All the lights are flashing on the printer

Solution The printer has encountered a hardware error and may need to be serviced. Unplug the power cord to the printer. Wait about 10 seconds, and then plug it in again. Turn on the printer. If the lights are still flashing, please go to www.hp.com/support, or contact HP Support for help.

Printing problems

Before contacting HP support, read this section for troubleshooting tips or go to the online support services at www.hp.com/support.

The printer does not print borderless photos when I print from the control panel

Solution Make sure the correct layout is selected when setting up the print job. When selecting photo and paper size, the image rectangle must be solidly filled with orange to indicate a borderless print.

Printing is very slow

Solution You may have one of the following situations: 1) you may be printing a PDF or a project containing high-resolution graphics or photos or 2) you may have selected the highest resolution for your printout. Large, complex projects containing graphics or photos print slower than text documents, especially at higher resolutions.

Paper does not feed into the printer correctly from the Main tray

Solution

- There may be too much paper loaded in the tray. Remove some paper and try printing again.
 - The Main tray may not be pushed in all the way. Push the Main tray all the way in.
 - The paper guides may not be adjusted correctly. Make sure the paper-width and paper-length guides fit close to the edges of the paper without bending the paper.
 - Two or more pieces of paper may be sticking together. Remove the paper from the Main tray, fan the edges of the stack to separate the sheets of paper, then reload the paper and try printing again.
 - If the paper is wrinkled or bent, try using different paper.
 - The paper may be too thin or too thick. Use HP inkjet paper for best results. For more information, see [Choose the right paper](#).
-

Printed pages are dropping off of the Output tray

Solution Always extend the Output tray extension when you print.

The printout is rippled or curled

Solution The project you are printing uses a larger amount of ink than normal. Print the project from a computer, and use the printer software to lower the ink saturation level. See the onscreen HP Photosmart printer help for more information.

The document printed at an angle or is off-center

Solution

- The paper may not be loaded correctly. Reload the paper, making sure it is correctly oriented in the Main tray and that the paper-width and paper-length

guides fit close to the edges of the paper. For paper-loading instructions, see [Paper loading tips](#).

- If you are using a two-sided printing accessory, try removing it, replacing the rear access door, and printing again.
 - The printer may need to be aligned. For more information, see [Aligning the printer](#).
-

Colors are not printing satisfactorily

Solution

- One of the color ink cartridges may be empty, resulting in another color being substituted during printing. Check the estimated ink levels by viewing the ink level icons from the Tools menu (Settings > Tools > Display Ink Gauge). If an ink cartridge is empty, replace it. For more information, see [Insert ink cartridges](#).
 - The printer may need to be aligned. For more information, see [Aligning the printer](#).
 - The print head may need to be cleaned. For more information, see [Care and maintenance](#).
-

No page came out of the printer or the paper jammed while printing

Solution

- The printer may need attention. Read the printer screen for instructions.
 - The power may be off or there may be a loose connection. Make sure the power is on and the power cord is securely connected.
 - You may not have any paper in the Main tray or Photo tray. Check that the paper is loaded correctly. For paper-loading instructions, see [Paper loading tips](#).
 - If the paper jammed while printing, try the following:
 - Turn off the printer, then unplug it from the power source. Clear the printer of any paper obstructing the paper path. Remove the rear access door. Gently remove the jammed paper from the printer, then replace the rear access door. If all jammed paper cannot be removed from the rear area of the printer, try removing paper jammed in the middle of the printer by opening the paper jam door located inside the top cover. For illustrations of the two places to clear a paper jam, see [Paper errors](#). When you are finished clearing the paper jam, plug the printer back in, turn it on, and try printing again.
 - If you were printing labels, make sure a label did not become unglued from the label sheet while going through the printer.
-

A blank page came out of the printer

Solution

- You may have begun printing and then cancelled the print job.

If you cancelled the print job before printing started, the printer may have already loaded paper in preparation for printing. The next time you print, the printer ejects the blank page before starting the new printing project.

- A print job with a large amount of data may have been sent to the printer. Wait for the printer to service the print head before it continues printing.
-

The printer asked me to print an alignment page

Solution Periodically, the printer needs to perform a print head alignment to maintain optimal print quality.

When prompted, load plain letter or A4 paper. Discard or recycle the alignment page.

The photo did not print using the default print settings

Solution You may have changed the print settings for the selected photo. Print settings you apply to an individual photo override the default print settings. Discard all print settings that have been applied to an individual photo by deselecting the photo. For more information, see [Settings](#).

The printer ejects the paper when preparing to print

Solution Direct sunlight could be interfering with the operation of the automatic paper sensor. Move the printer out of direct sunlight.

Print quality is poor

Solution

- One of the ink cartridges may be very low on ink, resulting in another color being substituted during printing. Check the estimated ink levels by viewing the ink level icons from the Tools menu (Settings > Tools > Display Ink Gauge). If an ink cartridge is low on ink, replace it. For more information, see [Insert ink cartridges](#).
- Use photo paper designed for the printer. For best results, use the papers recommended in [Choose the right paper](#).
- You may be printing on the wrong side of the paper. Make sure the paper is loaded with the side to be printed facing down.
- You may have selected a low-resolution setting on the digital camera. Reduce the size of the image and try printing again. For better results in the future, set the digital camera to a higher photo resolution.
- There may be a problem with an ink cartridge or with the print head. Try the following:
 - Remove and then reinsert each ink cartridge, one at a time, to make sure they are all properly seated.
 - Run the automatic print head cleaning procedure. For more information, see [Care and maintenance](#).

- Align the printer. For more information, see [Aligning the printer](#).
 - If print quality problems persist after you have tried all of the above solutions, contact HP Support.
-

Photos are not printing correctly

Solution

- You may have loaded the photo paper incorrectly. Load the photo paper with the side to be printed facing down.
 - The photo paper may not have fed into the printer correctly. Try the following:
 - Check for a paper jam. For more information, see [Paper errors](#).
 - Insert the photo paper as far as it will go into the Photo tray.
 - Load one sheet of photo paper at a time.
-

The photos I marked for printing in the digital camera do not print

Solution Some digital cameras let you mark photos for printing in both the camera's internal memory and on the memory card. If you mark photos in the internal memory, and then move photos from the camera's internal memory to the memory card, the marks do not transfer. Mark photos for printing after you transfer them from the digital camera's internal memory to the memory card.

Error messages

Before contacting HP support, read this section for troubleshooting tips or go to the online support services at www.hp.com/support.

Error messages that appear on the printer screen can be divided into the following types:

- [Paper errors](#)
- [Ink cartridge errors](#)
- [Memory card errors](#)
- [Computer printing errors](#)

Paper errors

Before contacting HP support, read this section for troubleshooting tips or go to the online support services at www.hp.com/support.

Error message: Paper jam. Clear jam then press OK.

Solution Turn off the printer, then unplug it from the power source. Clear the printer of any paper that may be obstructing the paper path. Remove the rear access door. Gently remove the jammed paper from the printer, then replace the rear access door.

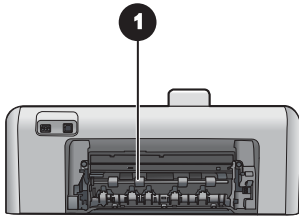

-
- 1 Remove the rear access door to clear paper jams.

If you cannot remove all jammed paper from the rear area of the printer, try removing paper jammed in the middle of the printer by opening the paper jam door located inside the top cover.

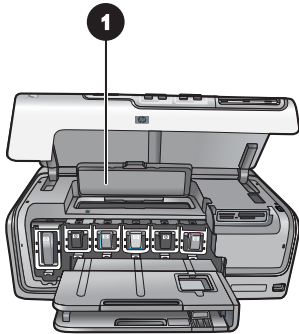

-
- 1 Open the paper jam door to clear paper jams in the middle of the printer.

Plug the printer back in and turn it on.

Error message: Out of paper. Load paper then press OK.

Solution Load paper, then press **OK** to print again. For paper-loading instructions, see [Paper loading tips](#).

Error message: Unsupported media size.

Solution The printer cannot use the size of paper loaded in the paper tray. Press **OK**, then load a supported paper size instead. For a list of supported paper sizes, see [Printer specifications](#).

Error message: Automatic paper sensor failed.

Solution The automatic paper sensor is obstructed or damaged. Try moving the printer out of direct sunlight, then press **OK** and try printing again. If this does not work, go to www.hp.com/support or contact HP Support.

Ink cartridge errors

Before contacting HP support, read this section for troubleshooting tips or go to the online support services at www.hp.com/support.

Error message: Wrong ink cartridge(s) installed

Solution The first time you set up and use your HP Photosmart printer, make sure to install the ink cartridges that were shipped with your printer. The ink in these ink cartridges is specially formulated to mix with the ink in the print head assembly.

To resolve this error, replace the affected ink cartridge(s) with the ink cartridges that were shipped with your HP Photosmart printer.

For more information on replacing ink cartridges, see [Insert ink cartridges](#).

Error message: Incorrect ink cartridge

Solution The indicated ink cartridge(s) cannot be used after the device has undergone initialization. Replace the ink cartridge(s) with the appropriate ink cartridges for your HP Photosmart printer. The cartridge numbers you can use with this printer appear on the back cover of this printed guide.

For more information on replacing ink cartridges, see [Insert ink cartridges](#).

Error message: Replace cartridges soon

Solution The indicated ink cartridge(s) are empty.

You might be able to continue printing for a short period of time with ink remaining in the print head assembly. Replace the indicated ink cartridge(s) or press **OK** to continue.

For more information on replacing ink cartridges, see [Insert ink cartridges](#).

Error message: Ink cartridge(s) are empty

Solution The indicated ink cartridge(s) are empty and there is not enough ink in the printhead reservoir for normal printing and servicing tasks. Replace the indicated ink cartridge(s) with new ink cartridge(s).

- If the black ink cartridge is empty, you can continue printing with the other color ink cartridges by selecting that option in the displayed printer screen prompts.
- If a color ink cartridge is empty, you can continue printing with the black ink cartridge by selecting that option in the displayed printer screen prompts.

Depending on the status of your print job, you can press **OK** to continue. If the HP Photosmart printer is in the middle of a print job, press **Cancel** and restart your print job.



Note Text and photo quality will differ from those printed when using all ink cartridges. If the empty ink cartridge(s) are not replaced soon, all printing will stop.

For more information on replacing ink cartridges, see [Insert ink cartridges](#).

Error message: Cannot print

Solution The indicated ink cartridge(s) are out of ink.

Replace the indicated ink cartridge(s) immediately so that you can resume printing.

The HP Photosmart printer cannot continue printing until the indicated ink cartridge(s) are replaced. All printing will stop.

For more information on replacing ink cartridges, see [Insert ink cartridges](#).

Error message: Ink cartridge problem

Solution The indicated ink cartridge(s) are missing or damaged.

Replace the indicated ink cartridge(s) immediately so that you can resume printing. If there are no ink cartridges missing from the HP Photosmart printer, the ink cartridge contacts might need to be cleaned.

For more information on replacing ink cartridges, see [Insert ink cartridges](#). For more information on cleaning the ink cartridge contacts, see [Care and maintenance](#).

If there are no ink cartridges missing from the HP Photosmart printer, and you still receive this message after cleaning the ink cartridge contacts, you will need a replacement ink cartridge. Remove the affected ink cartridge and look at the end-of-warranty date on the bottom, in YYYY/MMM/DD format. If it is before the end-of-warranty date, contact HP Support to obtain a replacement ink cartridge.

Error message: Ink Expiration Nearly Expired. —OR— Ink Cartridge(s) Expired.

Solution Each ink cartridge has an expiration date. The purpose of expiration is to protect the printing system and to ensure ink quality. When you receive an ink expiration message, remove and replace the ink cartridge, and then close the message. You can also continue printing without replacing the ink cartridge, by following the instructions on your computer screen. HP recommends replacing the expired ink cartridges. HP cannot guarantee the quality or reliability of expired ink cartridges. Device service or repairs required as a result of using expired ink will not be covered under warranty.

For more information on replacing ink cartridges, see [Insert ink cartridges](#).

Error message: Non-HP ink

Solution Replace the indicated ink cartridge(s) or press **OK** to continue.

HP recommends that you use genuine HP ink cartridges. Genuine HP ink cartridges are designed and tested with HP printers to help you easily produce great results, time after time.



Note HP cannot guarantee the quality or reliability of non-HP ink. Printer service or repairs required as a result of printer failure or damage attributable to the use of non-HP ink will not be covered under warranty.

If you believe you purchased genuine HP ink cartridge(s), go to:

www.hp.com/go/anticounterfeit

Error message: Original HP ink depleted

Solution Replace the indicated ink cartridge(s) or press **OK** to continue.

HP recommends that you use genuine HP ink cartridges. Genuine HP ink cartridges are designed and tested with HP printers to help you easily produce great results, time after time.



Note HP cannot guarantee the quality or reliability of non-HP ink. Printer service or repairs required as a result of printer failure or damage attributable to the use of non-HP ink will not be covered under warranty.

If you believe you purchased genuine HP ink cartridge(s), go to:

www.hp.com/go/anticounterfeit

Error message: Scheduled maintenance

Solution You must align the printer to ensure excellent print quality. With letter or A4 unused plain white paper in the Main tray, press **OK**. The HP Photosmart printer aligns the print head, calibrates the printer, and then prints a test page. Recycle or discard the test page.

Error message: Calibration error

Solution

- If you have color or photo paper loaded in the Main tray when you align the printer, the alignment might fail. Load unused plain white letter or A4 paper into the Main tray, and then try the alignment again. If the alignment fails again, you might have a defective sensor or ink cartridge; contact HP Support.
 - The ink cartridge or sensor is defective. Contact HP support.
-

Error message: Print cartridge cradle is stuck

Solution Remove any objects that are blocking the print head assembly.

To clear the print head assembly

1. Open the top cover, then open the paper jam door.

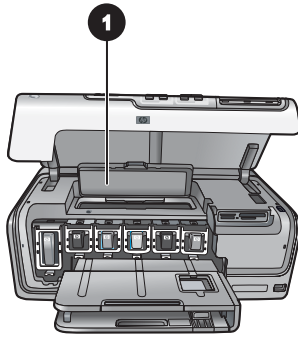

-
- 1 | Open the paper jam door to clear the print head assembly.
 2. Remove any objects that are blocking the print head assembly, including paper and any packing materials.
 3. Turn the printer off, then turn it on again.
 4. Close the paper jam door and the top cover.
-

Error message: Ink System Failure

Solution The print head assembly or the ink delivery system has failed and the HP Photosmart printer can no longer print.

Turn off the printer, then unplug its power cord. Wait about 10 seconds, then plug it in again. If this does not clear the error message, please contact HP Support.

Memory card errors

Before contacting HP support, read this section for troubleshooting tips or go to the online support services at www.hp.com/support.

Error message: Photo is missing. —OR— Some photos are missing.

Solution The printer cannot read the file on the memory card, or one or more files specified for the job are missing from the memory card. Try saving the photos to the computer using the digital camera rather than the memory card. If a photo is missing, you may have accidentally deleted the photo from the card.

Error message: Card access error. Job was cancelled. Press OK.—OR— File directory structure is corrupted. —OR— Card may be damaged. Job was cancelled. Press OK.

Solution The printer cannot read the data on the memory card and cannot complete any current print jobs. The data may be corrupted or there may be a physical problem with the memory card.

- Save the files to the computer and access them from there.
 - If this does not work, use a new memory card or reformat the memory card using the digital camera. Any photos on the memory card will be lost.
 - If this does not work, the photo files may be damaged or unreadable. Before you contact HP Support, try another memory card to determine if it is the printer or the memory card that is failing.
-

Error message: Cannot print photos.

Solution More than 10 photos specified for a print job may be corrupted, missing, or are an unsupported file type. For information about supported file types, see [Printer specifications](#).

- Save the photos to the computer using the digital camera rather than the memory card.
 - Save the files to the computer and print from the computer.
 - Print a photo index and reselect photos. For more information, see [Printing photos](#).
-

Error message: Card is password protected. Cannot access card.

Solution The printer cannot read the memory card because the card is password-protected. Follow these steps:

1. Remove the memory card from the printer.
 2. Insert the memory card in the device you originally used to store the password on the memory card.
 3. Remove the password from the memory card.
 4. Remove the memory card and reinsert it in the printer memory card slot.
 5. Try printing again.
-

Error message: Card is locked. Cannot access card.

Solution Make sure the lock switch on the card is in the unlocked position.

Error message: Card is not fully inserted. Push card in a little more.

Solution The printer can detect the memory card but cannot read it. Push the memory card gently into the memory card slot until it stops. For more information, see [Insert memory cards](#).

Error message: Use only one (1) card at a time. Please remove a memory card. —OR— Use only one (1) device at a time. Please remove/disconnect a device.

Solution The printer has two or more different types of memory cards inserted simultaneously, or a memory card is inserted and a digital camera is connected to the camera port at the same time. Remove memory cards or disconnect the camera until only one card is in the printer or only a camera is connected.

Error message: Card was removed. Job was cancelled. Press OK.

Solution You removed a memory card from the printer while it was busy printing a file from the card. Follow these steps:

1. Press **OK**.
2. Reinsert the memory card and print the selected photos again. The memory card must remain inserted until the print job is complete.

To avoid damage to memory cards in the future, do not remove them from the printer memory card slot while they are being accessed. For more information, see [Removing a memory card](#).

Error message: Camera selections (DPOF) file has error.

Solution The printer is unable to read a DPOF file due to corrupted data or an error on the memory card. Use the printer control panel to reselect the photos. For more information, see [Print photos from a memory card](#).

Error message: Some camera-selected photos are not on card.

Solution Some camera-selected photos are missing or have been deleted. Try the following:

- Confirm that you did not accidentally delete the photo from the memory card.
 - Reselect the photos again using the digital camera.
 - Print a new photo index to see the index numbers associated with each photo. For more information, see [Printing photos](#).
-

Error message: Cannot display this photo. —OR— Cannot display all photos. —OR— Photos are corrupted.

Solution The memory card contains image formats the printer does not support, or the files are corrupted. For a list of supported image formats, see [Printer specifications](#). Access photos using the computer. For information about accessing photos through the computer, see [Printing from a computer](#).

Error message: Unsupported card type.

Solution Use your camera to transfer the photos to your computer, and then print from your computer.

Error message: Some photo numbers are not on card.

Solution Use your camera to transfer the photos to your computer, and then print from your computer. If some photos are still missing, they may have been deleted from the memory card.

Computer and connectivity printing errors

Before contacting HP Support, read this section for troubleshooting tips or go to the online support services at www.hp.com/support.

Error message: Printer memory is full. Job was cancelled. Press OK.

Solution The printer encountered a problem when printing photos. Try the following:

- To clear the printer memory, turn the printer off, then turn it on again.
 - Print fewer photos at a time.
 - Save the photos to the computer and print from there.
 - Save the files to the computer using a memory card reader and then print from the computer.
-

Error message: Communication error. Check computer connection. Press OK. — OR— Data was not received. Check computer connection. Press OK to continue. —OR— No response from computer.

Solution The printer cannot communicate properly with the computer. The printer software may not be working or a cable may be loose. Make sure the USB cable is securely attached to both the computer and to the USB port on the back of the printer. If the cable is secure, verify that the printer software is installed.

Error message: Camera disconnected during print job.

Solution The print job will be cancelled. Reattach the USB cable to the camera and printer and resend the print job.

8 HP support

Support process

If you have a problem, follow these steps:

1. Check the documentation that came with the HP Photosmart printer.
2. Visit the HP online support Web site at www.hp.com/support. HP online support is available to all HP customers. It is the fastest source for up-to-date device information and expert assistance and includes the following features:
 - Fast access to qualified online support specialists
 - Software and driver updates for the HP Photosmart printer
 - Valuable HP Photosmart printer and troubleshooting information for common problems
 - Proactive device updates, support alerts, and HP newsletters that are available when you register the HP Photosmart printer
3. For Europe only: Contact your local point of purchase. If the HP Photosmart printer has a hardware failure, you will be asked to bring it back to your local point of purchase. (Service is provided at no charge during the device limited warranty period. After the warranty period, you will be quoted a service charge.)
4. Call HP support. Support options and availability vary by device, country/region, and language.

HP support by phone

For a list of support phone numbers, see the phone number list on the inside of the front cover.

Phone support period

One year of phone support is available in North America, Asia Pacific, and Latin America (including Mexico). To determine the duration of phone support in Europe, the Middle East, and Africa, go to www.hp.com/support. Standard phone company charges apply.

Placing a call

Call HP support while you are in front of the computer and the HP Photosmart printer. Be prepared to provide the following information:

- Device model number (located on the label on the front of the device)
- Device serial number (located on the back or bottom of the device)
- Messages that appear when the situation occurs
- Answers to these questions:
 - Has this situation happened before?
 - Can you re-create it?
 - Did you add any new hardware or software to your computer at about the time that this situation began?
 - Did anything else occur prior to this situation (such as a thunderstorm, device was moved, etc.)?

After the phone support period

After the phone support period, help is available from HP at an additional cost. Help may also be available at the HP online support Web site: www.hp.com/support. Contact your HP dealer or call the support phone number for your country/region to learn more about support options.

A Specifications

This section lists the minimum system requirements for installation of the HP Photosmart printer software, and provides selected printer specifications.

For a complete list of printer specifications and system requirements, see the onscreen HP Photosmart Printer Help. For information about viewing the onscreen HP Photosmart printer help, see [Welcome](#).

System requirements

Component	Windows PC minimum	Macintosh minimum
Operating system	Microsoft® Windows 98, 2000 Professional, Me, XP Home, and XP Professional	Mac® OS X 10.3, 10.4, and later
Processor	Intel® Pentium® II (or equivalent) and higher	G3, G4, G5 or Intel Core Duo or greater
RAM	64 MB (128 MB recommended)	Mac OS X 10.3, 10.4, and later: 128 MB
Free disk space	500 MB	150 MB
Video display	800 x 600, 16-bit or higher	800 x 600, 16-bit or higher
CD-ROM drive	4x	4x
Connectivity	USB: Microsoft Windows 98, 2000 Professional, Me, XP Home, and XP Professional PictBridge: using front camera port Bluetooth: using optional HP Bluetooth Wireless Adapter	USB: Front and back ports (Mac OS X 10.3, 10.4, and later) PictBridge: using front camera port Bluetooth: using optional HP Bluetooth Wireless Adapter
Browser	Microsoft Internet Explorer 5.5 or later	—

Printer specifications

Category	Specifications
Connectivity	USB: Microsoft Windows 98, 2000 Professional, Me, XP Home, and XP Professional; Mac OS X 10.3, 10.4, and later
Image file formats	JPEG Baseline TIFF 24-bit RGB uncompressed interleaved TIFF 24-bit YCbCr uncompressed interleaved TIFF 24-bit RGB packbits interleaved TIFF 8-bit gray uncompressed/packbits

(continued)

Category	Specifications
	TIFF 8-bit palette color uncompressed/packbits TIFF 1-bit uncompressed/packbits/1D Huffman
Video file formats	Motion-JPEG AVI Motion-JPEG QuickTime MPEG-1
Media specifications	Recommended maximum length: 61 cm (24 inch) Recommended maximum paper thickness: 292 µm (11.5 mil) Recommended maximum envelope thickness: 673 µm (26.5 mil)
Media sizes supported	Supported sizes when printing from a computer 7.6 x 12.7 cm to 22 x 61 cm (3 x 5 inch to 8.5 x 24 inch) Supported sizes when printing from the control panel Metric: A6, A4, 10 x 15 cm (with and without tab); Imperial: 3.5 x 5 inch, 4 x 6 inch (with and without tab), 4 x 12 inch, 5 x 7 inch, 8 x 10 inch, 8.5 x 11 inch; Other: Hagaki and L-size
Media types supported	Paper (plain, inkjet, photo, and panoramic photo) Envelopes Transparencies Labels Cards: index, greeting, Hagaki, A6, L-size Iron-on transfers Avery C6611 and C6612 photo sticker paper: 10 x 15 cm (4 x 6 inch), 16 rectangular or oval stickers per page
Memory cards	CompactFlash Type I and II Microdrive MultiMediaCard Secure Digital Memory Sticks xD-Picture Card
Memory card-supported file formats	Printing: See Image file formats earlier in this table. Saving: All file formats
Paper tray – media sizes supported	Main tray 8 x 13 cm to 22 x 61 cm (3 x 5 inch to 8.5 x 24 inch) Photo tray Up to 10 x 15 cm (4 x 6 inch), with or without tab Output tray All supported Main tray and Photo tray sizes
Paper tray capacity	Main tray

(continued)

Category	Specifications
	100 sheets of plain paper 14 envelopes 20–40 cards (depending on thickness) 30 sheets of labels 25 transparencies, iron-on transfers, or photo paper 10 sheets of photo paper Photo tray Output tray 20 sheets of photo paper 50 sheets of plain paper 10 cards or envelopes 25 sheets of labels or iron-on transfers
Operating environment	Recommended temperature range: 15–30 °C (59–86 °F) Maximum temperature range: 5–40 °C (41–104 °F) Storage temperature range: -40–60 °C (-40–140 °F) Recommended humidity range: 20–80% RH Maximum humidity range: 10–80% RH
Physical specifications	Height: 17.9 cm (6.8 inch). Width: 46.25 cm (18.2 inch) Depth: 38.7 cm (15.25 inch) Weight: 7.7 kg (17.0 lb).
Power consumption	Printing, Average: 75 W Printing, Maximum: 94 W Idle: 13.3–16.6 W
Power supply model number	HP Part # 0957-2105
Power requirement	100–240 VAC (± 10%), 50–60 Hz (± 3 Hz)
Ink cartridges	HP Yellow Ink Cartridge HP Cyan Ink Cartridge HP Light Cyan Ink Cartridge HP Magenta Ink Cartridge HP Light Magenta Ink Cartridge HP Black Ink Cartridge Note The cartridge numbers you can use with this printer appear on the back cover of this printed guide. If you have already used the printer several times, you can also find the cartridge numbers in the printer software. For more information, see Insert ink cartridges .
Print speed (maximum)	Black printouts: 32 pages per minute Color printouts: 31 pages per minute

(continued)

Category	Specifications
	Photos: 14 seconds for each 10 x 15 cm (4 x 6 inch) photo
USB support	Microsoft Windows 98, 2000 Professional, Me, XP Home, and XP Professional Mac OS X 10.3, 10.4, and later HP recommends using a USB 2.0 full-speed compliant cable 3 meters (10 feet) or less in length.

B HP Warranty

HP product	Duration of limited warranty
Software Media	90 days
Printer	1 year
Print or Ink cartridges	Until the HP ink is depleted or the "end of warranty" date printed on the cartridge has been reached, whichever occurs first. This warranty does not cover HP ink products that have been refilled, remanufactured, refurbished, misused, or tampered with.
Accessories	90 days

A. Extent of limited warranty

- Hewlett-Packard (HP) warrants to the end-user customer that the HP products specified above will be free from defects in materials and workmanship for the duration specified above, which duration begins on the date of purchase by the customer.
- For software products, HP's limited warranty applies only to a failure to execute programming instructions. HP does not warrant that the operation of any product will be interrupted or error free.
- HP's limited warranty covers only those defects that arise as a result of normal use of the product, and does not cover any other problems, including those that arise as a result of:
 - Improper maintenance or modification;
 - Software, media, parts, or supplies not provided or supported by HP;
 - Operation outside the product's specifications;
 - Unauthorized modification or misuse.
- For HP printer products, the use of a non-HP cartridge or a refilled cartridge does not affect either the warranty to the customer or any HP support contract with the customer. However, if printer failure or damage is attributable to the use of a non-HP or refilled ink cartridge, HP will charge its standard time and materials charges to service the printer for the particular failure or damage.
- If HP receives, during the applicable warranty period, notice of a defect in any product which is covered by HP's warranty, HP shall either repair or replace the product, at HP's option.
- If HP is unable to repair or replace, as applicable, a defective product which is covered by HP's warranty, HP shall, within a reasonable time after being notified of the defect, refund the purchase price for the product.
- HP shall have no obligation to repair, replace, or refund until the customer returns the defective product to HP.
- Any replacement product may be either new or like-new, provided that it has functionality at least equal to that of the product being replaced.
- HP products may contain remanufactured parts, components, or materials equivalent to new in performance.
- HP's Limited Warranty Statement is valid in any country where the covered HP product is distributed by HP. Contracts for additional warranty services, such as on-site service, may be available from any authorized HP service facility in countries where the product is distributed by HP or by an authorized importer.

B. Limitations of warranty

TO THE EXTENT ALLOWED BY LOCAL LAW, NEITHER HP NOR ITS THIRD PARTY SUPPLIERS MAKES ANY OTHER WARRANTY OR CONDITION OF ANY KIND, WHETHER EXPRESS OR IMPLIED WARRANTIES OR CONDITIONS OF MERCHANTABILITY, SATISFACTORY QUALITY, AND FITNESS FOR A PARTICULAR PURPOSE.

C. Limitations of liability

- To the extent allowed by local law, the remedies provided in this Warranty Statement are the customer's sole and exclusive remedies.
- TO THE EXTENT ALLOWED BY LOCAL LAW, EXCEPT FOR THE OBLIGATIONS SPECIFICALLY SET FORTH IN THIS WARRANTY STATEMENT, IN NO EVENT SHALL HP OR ITS THIRD PARTY SUPPLIERS BE LIABLE FOR DIRECT, INDIRECT, SPECIAL, INCIDENTAL, OR CONSEQUENTIAL DAMAGES, WHETHER BASED ON CONTRACT, TORT, OR ANY OTHER LEGAL THEORY AND WHETHER ADVISED OF THE POSSIBILITY OF SUCH DAMAGES.

D. Local law

- This Warranty Statement gives the customer specific legal rights. The customer may also have other rights which vary from state to state in the United States, from province to province in Canada, and from country to country elsewhere in the world.
- To the extent that this Warranty Statement is inconsistent with local law, this Warranty Statement shall be deemed modified to be consistent with such local law. Under such local law, certain disclaimers and limitations of this W Statement may not apply to the customer. For example, some states in the United States, as well as some governments outside the United States (including provinces in Canada), may:
 - Preclude the disclaimers and limitations in this Warranty Statement from limiting the statutory rights of a consumer (e.g., the United Kingdom);
 - Otherwise restrict the ability of a manufacturer to enforce such disclaimers or limitations; or
 - Grant the customer additional warranty rights, specify the duration of implied warranties which the manufacturer cannot disclaim, or allow limitations on the duration of implied warranties.
- THE TERMS IN THIS WARRANTY STATEMENT, EXCEPT TO THE EXTENT LAWFULLY PERMITTED, DO NOT EXCLUDE, RESTRICT, OR MODIFY, AND ARE IN ADDITION TO, THE MANDATORY STATUTORY RIGHTS APPLICABLE TO THE SALE OF THE HP PRODUCTS TO SUCH CUSTOMERS.

Index

A

- accessories 11
- accessories, two-sided printing 11
- after the support period 60
- aligning the printer 39
- alignment page 39
- alignment, required 54
- antique coloration 29

B

- Bluetooth
 - connecting to printer 23, 31
 - menu settings 11
 - wireless printer adapter 11
- borderless prints 29
- buttons 10

C

- calling HP support 59
- cameras
 - connecting to printer 23, 31
 - direct-printing 25
 - PictBridge 25
 - port 8
 - printing from 25
- care and maintenance 39
- cartridges. *See* ink cartridges
- cleaning
 - copper-colored contacts 40
 - print head 40
 - printer 39
- color effects 29
- CompactFlash 20
- computer
 - connecting to printer 31
 - printing from 35
 - saving photos to 33
 - system requirements 61
- control panel 10

D

- damaged, ink cartridge 53

- date and time stamps 29
- digital cameras. *See* cameras
- Digital Print Order Format 24
- documentation, printer 7
- DPOF 24

E

- e-mailing photos 33
- energy consumption 2
- Energy Star 2
- error messages 50

F

- file formats, supported 20, 61
- Frequently asked questions 45

G

- Getting help 45

H

- Help 45
- Hewlett-Packard Company notices 2
- home, screen 11
- HP direct-printing digital cameras 25
- HP Instant Share 31
- HP Photosmart Essential 35
- HP Photosmart Premier 35
- HP Photosmart Share 33, 36
- HP Photosmart Studio (Mac only) 36
- HP Software Update 42

I

- ink
 - checking level 41
 - empty 52
 - replace soon 52
- ink cartridges
 - damaged 53
 - empty 52
 - expired 53
 - HP ink depleted 54
 - incorrect 52
 - ink level, checking 19

- inserting 19
- missing 53
- non-HP ink 53
- printer alignment 54
- replace soon 52
- replacing 19
- storing 43
- testing 41
- ink level, checking 19
- inserting
 - ink cartridges 19
 - memory cards 21
- iPod 32

J

- JPEG file formats 20

L

- layout and photo size 26
- lights 10
- Load paper 15

M

- Macintosh
 - HP Photosmart Mac software 36
- memory cards
 - inserting 21
 - printing from 23
 - removing 22
 - saving photos to a computer 33
 - supported types 20
- Memory Sticks 20
- Microdrive 20
- missing ink cartridge 53
- MPEG-1 file format 20
- MultiMediaCard 20

P

- Paper
 - load 15
- paper
 - buying and choosing 15
 - maintaining 15, 43
 - specifications 61

- trays 8
- phone support 59
- phone support period
 - period for support 59
- photos
 - antique coloration 29
 - cropping 29
 - date and time stamp 29
 - e-mailing 33
 - framing 29
 - improving quality 28
 - printing 23
 - saving to computer 31
 - sepia tones 29
 - supported file formats 20
 - zooming 29
- Photosmart Share. See HP Photosmart Share
- PictBridge cameras 25
- placing a call 59
- print head
 - cleaning 40
 - failure 55
 - stalled 54
- print quality
 - changing 23
- Printer
 - Specifications 61
- printer
 - accessories 11
 - care and maintenance 39
 - cleaning 39
 - connecting 23, 31
 - documentation 7
 - error messages 50
 - home 11
 - parts 8
 - specifications 61
 - storing 43
- printer software
 - updating 42
- printer software, updating 35
- printing
 - from a computer 35
 - from Bluetooth device 23
 - from cameras 25
 - from memory cards 23
 - from PictBridge camera 23
 - photos 23
 - range of photos 23
 - test page 41
 - without computer 23

- Q**
 - quality
 - photo paper 43
 - photos 28
 - printing test page 41
 - Questions and Answers 45
- R**
 - range
 - printing 23
 - regulatory notices
 - regulatory model
 - identification number 2
 - removing memory cards 22
 - replacing ink cartridges 19
- S**
 - saving photos to computer 31
 - Secure Digital 20
 - sepia tones 29
 - Sony Memory Sticks. See Memory Sticks
 - Specifications 61
 - storing
 - ink cartridges 43
 - photo paper 43
 - printer 43
 - support 59
 - support process 59
 - system requirements 61
- T**
 - test page 41
 - TIFF file format 20
 - transporting printer 11
 - trays, paper 8
 - Troubleshooting 45
 - troubleshooting
 - error messages 50
 - two-sided printing 11
- U**
 - USB
 - connection type 31
 - port 8
 - specifications 61
- V**
 - video clip
 - supported file formats 20
- X**
 - xD-Picture Card 20