

HP Photosmart D5100 series

Setup-Handbuch / Guida all'installazione / Guide d'installation / Installatiehandleiding



Q7090-90174

DE IT FR NL



Achtung Windows-Benutzer: Schließen Sie das USB-Kabel (separat erhältlich) erst dann an, wenn Sie während der Softwareinstallation dazu aufgefordert werden.

Utenti Windows: per il collegamento del cavo USB (venduto separatamente), attendere fino a quando viene richiesto durante l'installazione del software.

Utilisateurs Windows : ne connectez pas le câble USB (vendu séparément) avant d'y être invité pendant l'installation du logiciel.

Opmerking voor Windows-gebruikers: sluit de USB-kabel (afzonderlijk verkocht) pas aan wanneer er tijdens de installatie van de software om wordt gevraagd.

1 Packen Sie den Drucker aus Disimballare la stampante Déballez l'imprimante Pak de printer uit

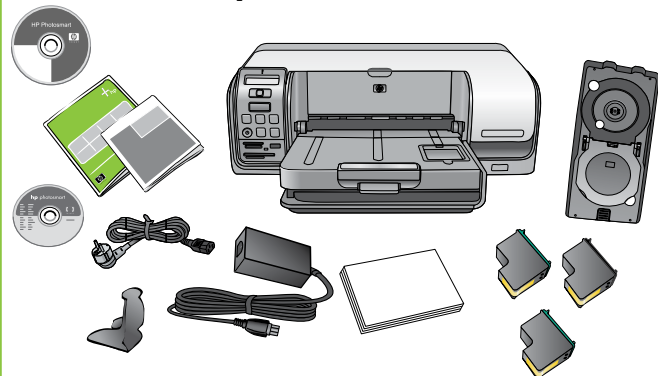

Entfernen Sie das Verpackungsmaterial aus dem Druckerinneren und außen am Drucker. Die Inhalte variieren je nach Land/Region.

Eliminare il materiale di imballaggio all'esterno e all'interno della stampante. Il contenuto può variare in base al paese/all'area geografica.

Retirez l'emballage situé à l'intérieur et autour de l'imprimante. Le contenu peut varier en fonction du pays/de la région.

Verwijder het verpakkingsmateriaal in en om de printer. De inhoud kan per land/regio variëren.

2 Schließen Sie nur das Netzkabel an Collegare solo il cavo di alimentazione Ne branchez que le câble d'alimentation Sluit alleen het netsnoer aan

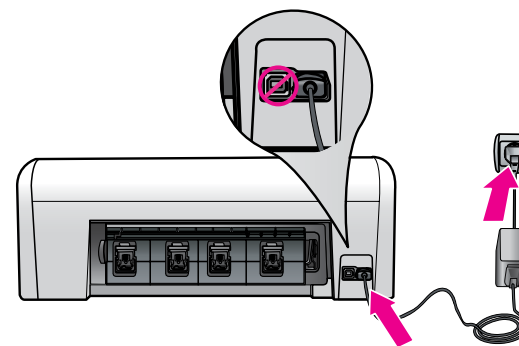

3 Schalten Sie den Drucker ein Accendere la stampante Mettez sous tension l'imprimante Zet de printer aan

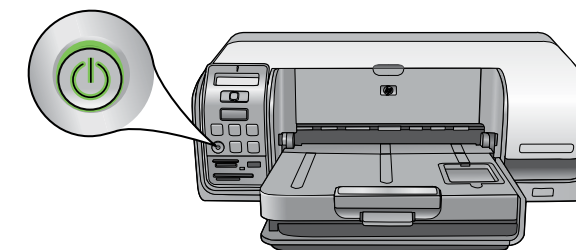

4 Einlegen von Normalpapier Caricare carta comune Chargez du papier ordinaire Plaats gewoon papier

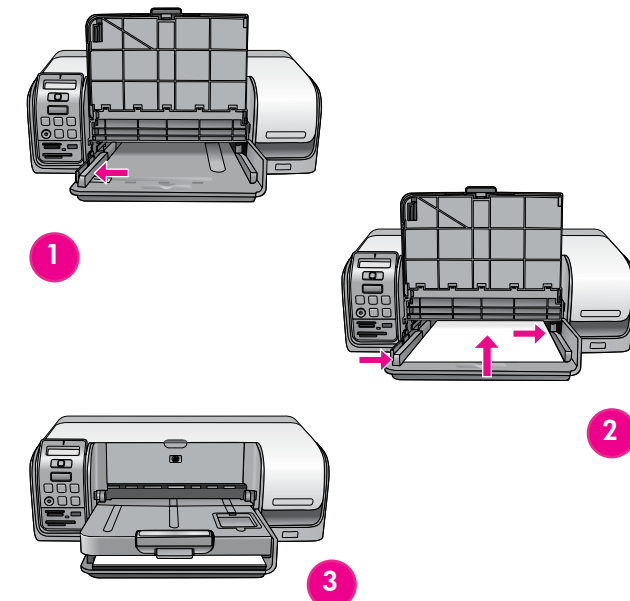

5 Druckpatronen einsetzen Installare le cartucce di stampa Installez les cartouches Installeer de printcartridges



Achtung! Berühren Sie nicht die kupferfarbenen Kontakte oder die Tintendüsen.

Avvertimento: evitare di toccare o di rimuovere i contatti color rame o gli ugelli dell'inchiostro.

Attention ! Evitez de toucher ou de retirer les buses d'encre ou les contacts en cuivre.

Let op! Raak de koperkleurige contactpunten en inktspoeiers niet aan en verwijder deze niet.

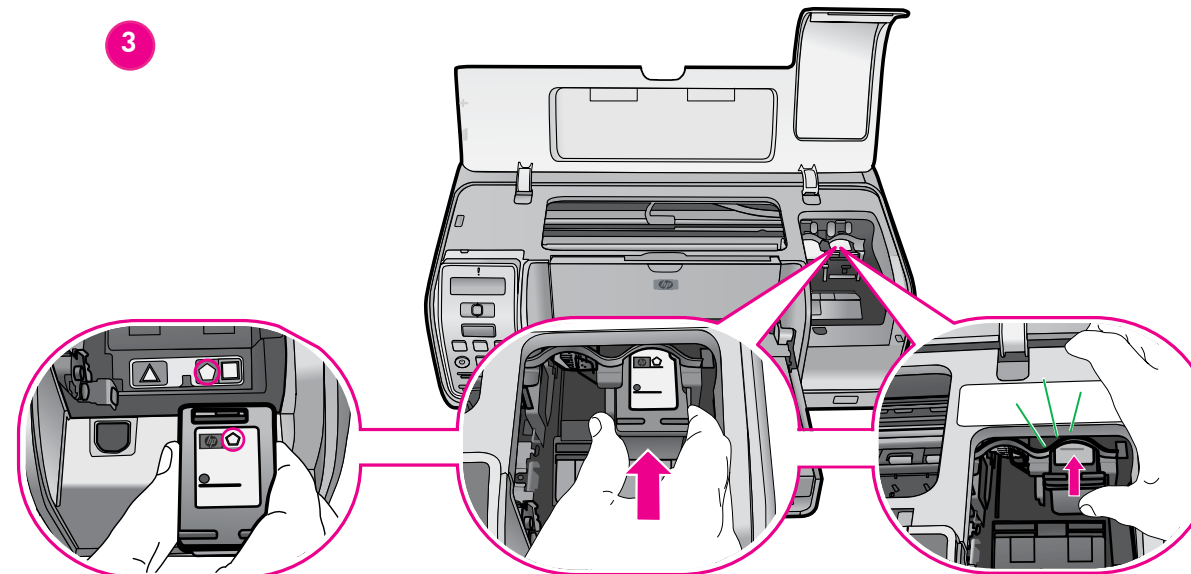
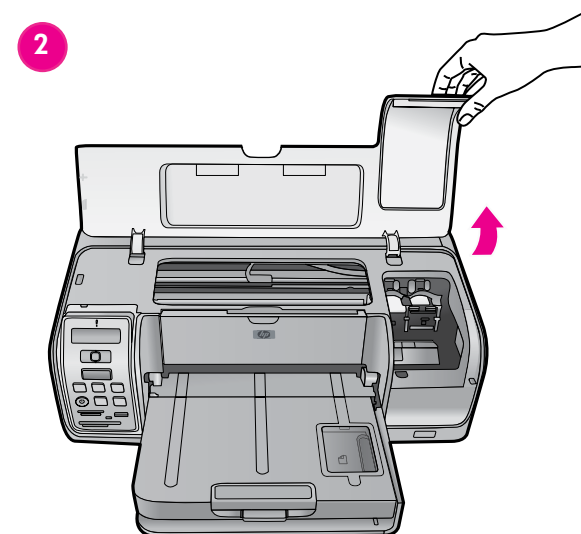
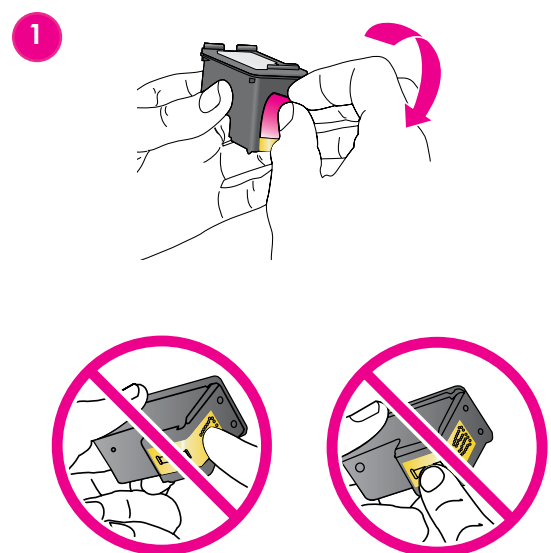



6 Legen Sie die CD in den Computer ein, und klicken Sie auf das Installationssymbol, um die HP Photosmart-Software zu installieren.

Inserire il CD nel computer e fare clic sull'icona di installazione per installare il software HP Photosmart

Insérez le CD dans le lecteur de l'ordinateur, puis cliquez sur l'icône d'installation du logiciel HP Photosmart

Plaats de cd in de computer en klik op het installatiepictogram om de HP Photosmart software te installeren



Achtung Windows-Benutzer: Schließen Sie das USB-Kabel erst dann an, wenn Sie während der Softwareinstallation dazu aufgefordert werden.

Utenti Windows: per il collegamento del cavo USB, attendere fino a quando viene richiesto durante l'installazione del software.

Utilisateurs Windows : ne connectez pas le câble USB avant d'y être invité pendant l'installation du logiciel.

Opmerking voor Windows-gebruikers: sluit de USB-kabel pas aan wanneer er tijdens de installatie van de software om wordt gevraagd.

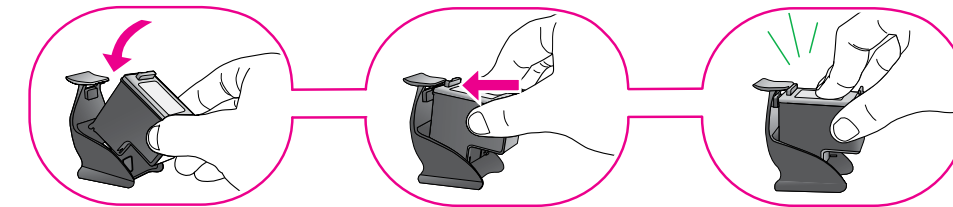

Bewahren Sie die zusätzliche Druckpatrone in der dafür vorgesehenen Schutzhülle auf, wenn sie sich nicht im Drucker befindet.

Quando non si trova all'interno della stampante, conservare la cartuccia aggiuntiva nella protezione delle cartucce di stampa.

Si la cartouche supplémentaire n'est pas dans l'imprimante, stockez-la dans son dispositif de protection.

Bewaar de printcartridges die u niet gebruikt in de printcartridgehouder.

Windows PC

Windows® 98, Me, 2000 Professional, XP Home, XP Professional



1 USB-Verbindung
Connessione USB
Connexion USB
USB-aansluiting



2



3

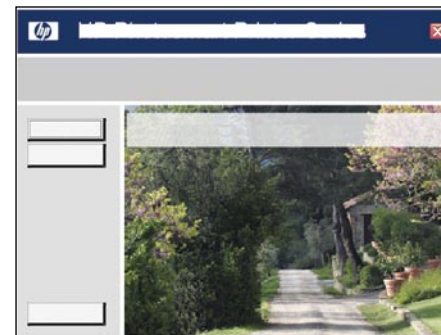

4

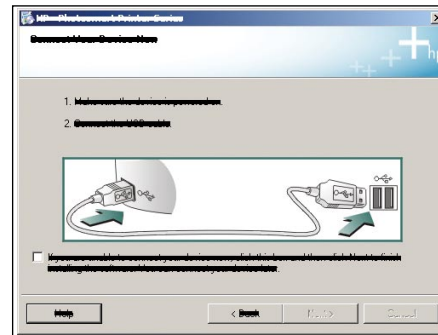

5

USB-Verbindung
Connessione USB
Connexion USB
USB-aansluiting

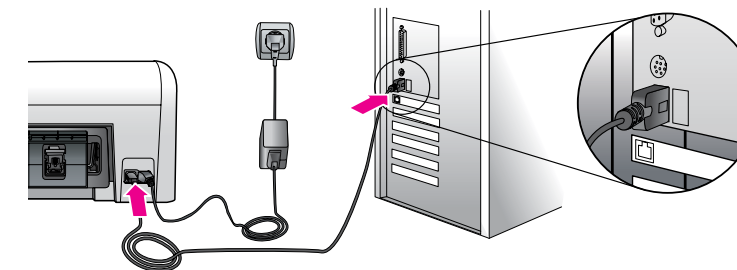

Macintosh

Macintosh OS X v10.3, 10.4 +

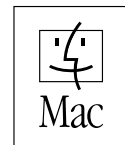

1

USB-Verbindung
Connessione USB
Connexion USB
USB-aansluiting

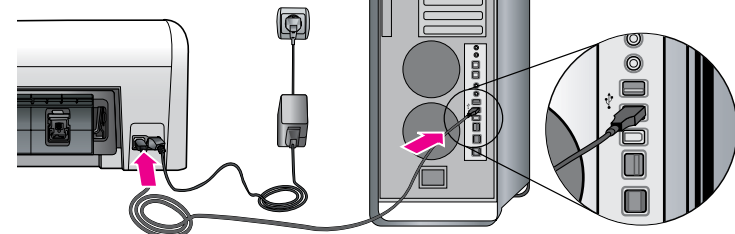

2



3

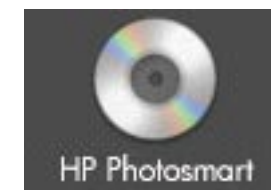

4



Benötigen Sie weitere Informationen?

Altre domande?

Plus d'informations ?

Meer informatie nodig?

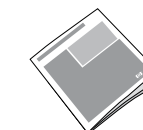

Grundlagenhandbuch
Guida di base
Guide de base
Basishandleiding



Online-Druckerhilfe
Guida in linea della stampante
Aide en ligne de l'imprimante
On line Help bij de printer



Benutzerhandbuch auf CD
Guida dell'utente su CD
Guide de l'utilisateur sur CD
Gebruikershandleiding op cd



www.hp.com/support