

HP Pavilion dv9000 Entertainment PC Maintenance and Service Guide



© Copyright 2007 Hewlett-Packard
Development Company, L.P.

Bluetooth is a trademark owned by its proprietor and used by Hewlett-Packard Company under license. Intel and Core are trademarks or registered trademarks of Intel Corporation or its subsidiaries in the United States and other countries. Microsoft, Windows, and Windows Vista are either trademarks or registered trademarks of Microsoft Corporation in the United States and/or other countries.

The information contained herein is subject to change without notice. The only warranties for HP products and services are set forth in the express warranty statements accompanying such products and services. Nothing herein should be construed as constituting an additional warranty. HP shall not be liable for technical or editorial errors or omissions contained herein.

First Edition: April 2007

Document Part Number: 448374-001

Safety warning notice

- ⚠ **WARNING!** To reduce the possibility of heat-related injuries or of overheating the computer, do not place the computer directly on your lap or obstruct the computer air vents. Use the computer only on a hard, flat surface. Do not allow another hard surface, such as an adjoining optional printer, or a soft surface, such as pillows or rugs or clothing, to block airflow. Also, do not allow the AC adapter to contact the skin or a soft surface, such as pillows or rugs or clothing, during operation. The computer and the AC adapter comply with the user-accessible surface temperature limits defined by the International Standard for Safety of Information Technology Equipment (IEC 60950).
-

Table of contents

1 Product description

2 External component identification

Top components	5
Display and top components	5
QuickPlay buttons	7
Keys	8
TouchPad	9
Front components	10
Right-side components	11
Left-side components	11
Bottom components	13

3 Illustrated parts catalog

Serial number location	15
Computer major components	16
Display assembly components	21
Plastics Kit	23
Cable Kit	24
Mass storage devices	25
Miscellaneous parts	26
Sequential part number listing	27

4 Removal and replacement procedures

Preliminary replacement requirements	33
Tools required	33
Service considerations	33
Plastic parts	33
Cables and connectors	34
Drive handling	34
Grounding guidelines	35
Electrostatic discharge damage	35
Packaging and transporting guidelines	36
Workstation guidelines	36
Equipment guidelines	37
Unknown user password	38
Component replacement procedures	39
Serial number	39

Battery	40
Camera module	41
Display inverter	43
Hard drive	45
Computer feet	47
Memory module	47
RTC battery	49
WLAN module	50
Optical drive	52
Switch cover	54
Keyboard	56
Speaker assembly	59
Power button board	60
Display assembly	62
Top cover	68
Wireless switch board	73
Bluetooth module	75
Front USB board	77
ExpressCard assembly	78
Top cover trim	80
Display switch module	82
Rear USB board	83
System board	85
Audio board	89
Fan/heat sink assembly	91
Processor	94

5 Setup Utility

Starting the Setup Utility	97
Changing the language of the Setup Utility	97
Navigating and selecting in the Setup Utility	98
Displaying system information	98
Restoring default settings in the Setup Utility	98
Using advanced Setup Utility features	99
Closing the Setup Utility	99
Setup Utility menus	99

6 Specifications

Computer specifications	101
15.4-inch, SXGA+ display specifications	102
15.4-inch WXGA+ display specifications	103
Hard drive specifications	104
DVD±RW and CD-RW Super Multi Double-Layer Combo Drive specifications	105
System DMA specifications	106
System interrupt specifications	107
System I/O address specifications	108
System memory map specifications	110

7 Screw listing

Phillips PM2.5×8.0 captive screw	111
Phillips PM3.0×4.0 screw	112
Phillips PM2.5×5.0 captive screw	113
Phillips PM2.0×11.0 screw	115
Phillips PM2.5×8.0 screw	116
Phillips PM2.0×3.0 screw	120
Phillips PM2.5×5.0 screw	122
Phillips PM2.5×6.0 screw	127
Phillips PM2.0×4.0 screw	128
Phillips 2.5×4.0 captive screw	129

8 Backup and Recovery

Recovering system information	131
Backing up your information	131
When to back up	131
Back up suggestions	132
Using system restore points	132
When to create restore points	132
Create a system restore point	132
Restore to a previous date and time	133
Creating recovery discs	133
Reinstalling software programs and drivers	134
Reinstalling preinstalled programs and drivers	134
Reinstalling programs from discs	134
Performing a recovery	135
Recovering from the recovery discs	135
Recovering from the partition on the hard drive	135
Deleting the recovery partition on the hard drive	136
Updating reinstalled software	136

9 Connector pin assignments

Audio-out (headphone)	137
Audio-in (microphone)	137
External monitor	138
RJ-11 (modem)	139
RJ-45 (network)	139
S-Video-out	140
Universal Serial Bus	140

10 Power cord set requirements

Requirements for all countries or regions	141
Requirements for specific countries or regions	142

11 Recycling

Battery	143
Display	143

Index	149
--------------------	------------

1 Product description

Category	Description
Product Name	HP Pavilion dv9000 Entertainment PC
Processors	<ul style="list-style-type: none">• Intel® Core™ Duo T7500 2.2-GHz (4 MB of L2 cache)• Intel Core T7300 2.0-GHz (4 MB of L2 cache)• Intel Core T7100 1.8-GHz (2 MB of L2 cache)
Chipset	Northbridge: Intel GM965 Southbridge: ICH8m
Graphics	<ul style="list-style-type: none">• nVidia NB8P-SE (G86M-128bit) with 256 MB of dedicated video memory (16M × 16 DDR2 × 8 PCs) with 256-MB video memory when system memory has < 1 GB (256 MB + 0 MB Turbo Cache)• Intel Extreme Graphics - Mobile Intel Graphics Media Accelerator X3100 (Mobile Intel GMA X3100) UMA (integrated) with shared video memory, up to 64 MB on computer models with 512 MB of system memory, up to 256 MB on computer models with ≥ 1024 MB of system memory (memory size is dynamic change)
Panels	<ul style="list-style-type: none">• 17.0-inch" single-lamp WXGA+ BrightView 1680 × 1050), 16:9 wide aspect ratio, 200 nits typical brightness• 17.0-inch" single-lamp WXGA+ BrightView (1440 × 900), 16:9 wide aspect ratio, 200 nits typical brightness
Memory	<ul style="list-style-type: none">• Two SODIMM slots• Customer-accessible/upgradable• DDRII PC2-5300 (667-MHz)• Dual channel support• Supports up to 2048 MB of system memory<ul style="list-style-type: none">◦ 2048 MB total system memory (1024 MB × 2)◦ 1024 MB total system memory (1024 MB × 1)
Hard drives	<ul style="list-style-type: none">• Supports all Serial ATA (SATA) 9.5-mm, 2.5-inch hard drives• Supports second hard drive with software RAID• Single hard drive configurations<ul style="list-style-type: none">◦ 200-GB, 4200-rpm◦ 160-GB, 5400-rpm

Category	Description
	<ul style="list-style-type: none"> ◦ 120-GB, 5400-rpm ◦ 100-GB, 7200-rpm ◦ 80-GB, 5400-rpm • Dual hard drive configurations <ul style="list-style-type: none"> ◦ 320-GB, 5400-rpm (160 GB × 2) ◦ 280-GB, 5400-rpm (160 GB + 120 MB) ◦ 240-GB, 5400-rpm (120 GB × 2) ◦ 200-GB, 5400-rpm (120 GB + 80 GB)
Optical drives	<ul style="list-style-type: none"> • 12.7-mm tray load • Parallel ATA • Fixed (1 screw for removal) • DVD±RW and CD-RW Super Multi Double-Layer Combo Drive with LightScribe • DVD±RW and CD-RW Super Multi Double-Layer Combo Drive
Camera	<ul style="list-style-type: none"> • Low-light VGA camera • Fixed (no tilt) • 640 × 480 by 20 frames per second
Diskette drive	Supports external USB drive only
Audio	<ul style="list-style-type: none"> • HD Audio (Realtek ALC861-VD-GR) • Supports Microsoft Premium Requirements • Pavilion-branded Altec Lansing speakers • 2 omnidirectional microphones, dual array with appropriate software (supports beam forming, echo cancellation, and noise suppression)
Modem	<ul style="list-style-type: none"> • 56K V.92 data/fax modem (SilonLab ML3080 AMoM) • Supports all world-wide certification requirements
Ethernet	Integrated Realtek RT8101e 10/100 network interface card (NIC)
Wireless	<p>Integrated wireless local area network (WLAN) options by way of wireless module:</p> <ul style="list-style-type: none"> • Intel PRO wireless 3945 a/b/g and b/g with 2 antennae built into the display assembly • Intel WLAN + Bluetooth® • 802.11b/g for use only in North America, includes two 2.4-GHz antennae in display assembly • Intel PRO wireless 4965 a/b/g with 2 antennae built into the display assembly and a/b/g/n with 3 antennae built into the display assembly

Category	Description
External media card	<ul style="list-style-type: none"> • One ExpressCard 54 slot, supports Hybrid Analog+ATSC and DVBT TV tuner • 5-in-1 Digital Media Slot, supports SD, MMC, SDIO, MS, MSpro, xD • One Mini PCIe slot
Ports	<ul style="list-style-type: none"> • Audio-in (mono microphone) • Audio-out (stereo headphone) • Audio-out (stereo headphone with S/PDIF) • Consumer infrared • High-definition multimedia interface (HDMI, on select models only) • IEEE 1394a • RJ-11 (modem) • RJ-45 (Ethernet, includes link and activity lights) • S-Video-out • USB (4 on computer models not equipped with a fingerprint reader, 3 on computer models equipped with a fingerprint reader) • VGA (Dsub 15-pin) • 2-pin AC power for 65W AC adapter
Docking	Expansion port 3 supports the HP xb3000 Notebook Expansion Base and HP Notebook QuickDock
Keyboard/pointing devices	<ul style="list-style-type: none"> • 17-inch full-size keyboard with numeric keypad • Touchpad supports 2-way scrolling • Taps enabled as default
Power requirements	<ul style="list-style-type: none"> • 8-cell 2.55-Ah Li-ion battery • 8-cell 2.20-Ah Li-ion battery • 65-W AC adapter with localized cable plug support (2-wire plug with ground pin, supports 2-pin DC connector)
Security	<ul style="list-style-type: none"> • Security cable slot • Fingerprint reader (select models only)
Operating system	<p>Preinstalled:</p> <ul style="list-style-type: none"> • Windows Vista™ with embedded QuickPlay Direct • Windows Vista Business (32-bit) • Windows Vista Ultimate (64-bit) • Windows Vista Premium (64-bit)
Serviceability	<p>End-user replaceable parts:</p> <ul style="list-style-type: none"> • AC adapter • Battery (system)

Category	Description
	<ul style="list-style-type: none"><li data-bbox="558 210 766 252">• Hard drives (2)<li data-bbox="558 262 766 304">• Memory module<li data-bbox="558 315 766 357">• Optical drive<li data-bbox="558 367 766 409">• WLAN module

2 External component identification

Top components

Display and top components

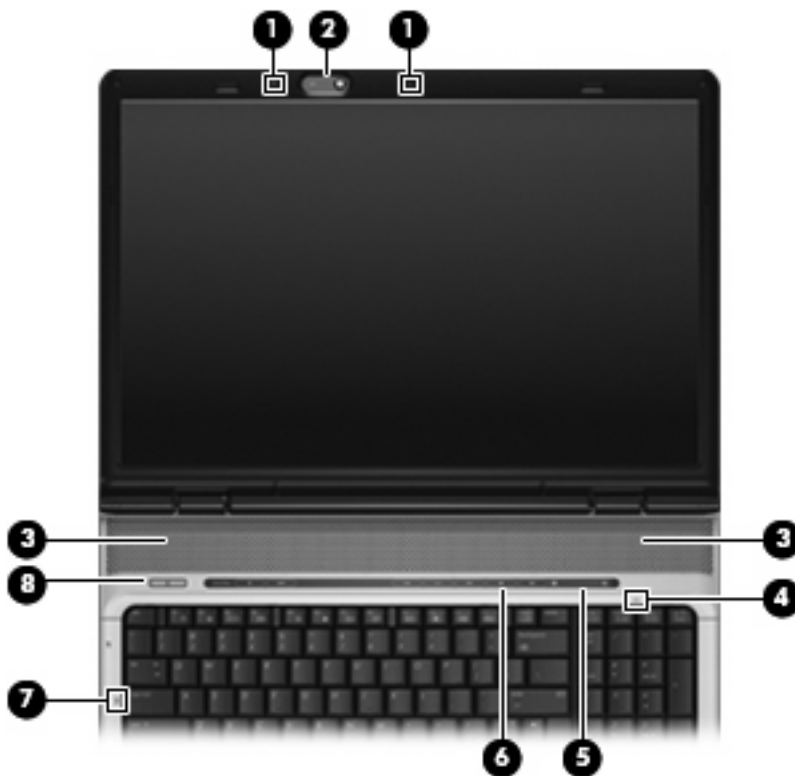

Item	Component	Description
(1)	Internal microphones (2) (select models only)	Record sound. NOTE: If there is a microphone icon next to each microphone opening, the computer has internal microphones.
(2)	Integrated camera (select models only)	Records video and captures still photographs.
(3)	Speakers (2)	Produce sound.
(4)	Num lock light	On: Num lock is on or the embedded numeric keypad is enabled.

Item	Component	Description
(5)	Volume scroll zone	Adjusts speaker volume. Slide your finger to the left to decrease volume and to the right to increase volume. You can also tap the minus sign on the scroll zone to decrease volume, or tap the plus sign on the scroll zone to increase volume.
(6)	Volume mute button	Mutes and restores the speaker sound.
(7)	Caps lock light	On: Caps lock is on.
(8)	Power button*	<ul style="list-style-type: none"> • When the computer is off, press the button to turn on the computer. • When the computer is on, press the button to shut down the computer. • When the computer is in the Sleep state (Windows Vista) or in Standby (Windows XP), press the button briefly to exit Sleep or Standby. • When the computer is in Hibernation, press the button briefly to exit Hibernation. <p>If the computer has stopped responding and Windows® shutdown procedures are ineffective, press and hold the power button for at least 5 seconds to turn off the computer.</p> <p>To learn more about power settings, select Start > Control Panel > System and Maintenance > Power Options.</p>

*This table describes factory settings. For information about changing factory settings, refer to the user guides located in Help and Support.

QuickPlay buttons

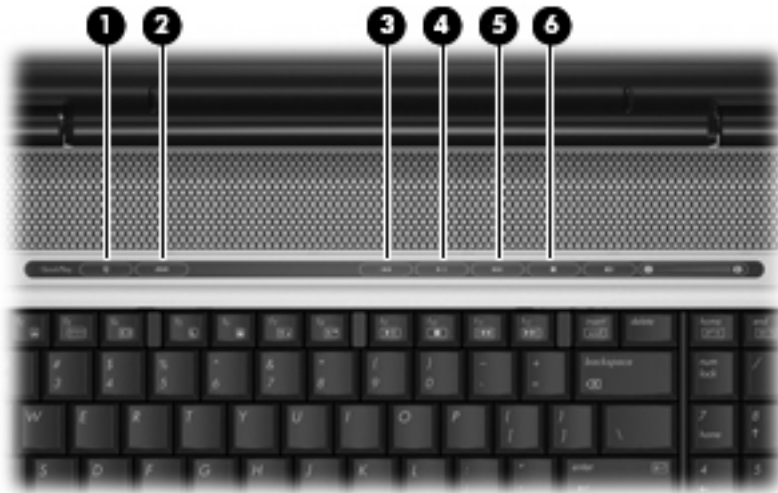

Item	Component	Description
(1)	Media button	<p>Launches the QuickPlay program.</p> <p>NOTE: If the computer has been set up to require a logon password, you may be asked to log on to Windows. QuickPlay launches after you log on. Refer to the QuickPlay online Help for more information.</p>
(2)	DVD button	<p>Launches the DVD playback feature of the QuickPlay program.</p> <p>NOTE: If the computer has been set up to require a logon password, you may be asked to log on to Windows. QuickPlay launches after you log on. Refer to the QuickPlay online Help for more information.</p>
(3)	Previous/rewind button	<p>When a disc is playing in the optical drive:</p> <ul style="list-style-type: none"> Plays the previous track or chapter, when pressed once. Rewinds when pressed with the fn key.
(4)	Play/pause button	Plays or pauses the disc.
(5)	Next/fast forward button	<ul style="list-style-type: none"> Plays the next track or chapter when the button is pressed once. Fast forwards media when pressed simultaneously with the fn key.
(6)	Stop button	Stops the disc.

Keys

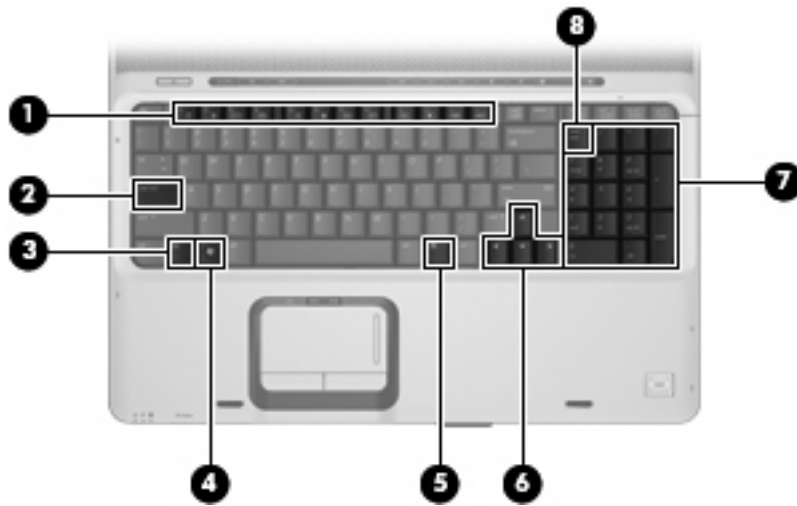

Item	Component	Function
(1)	Function keys	Execute frequently used system functions when pressed in combination with the <code>fn</code> key.
(2)	<code>caps lock</code> key	Enables caps lock and turns on the caps lock light.
(3)	<code>fn</code> key	Executes frequently used system functions when pressed in combination with a function key or the <code>esc</code> key.
(4)	Windows logo key	Displays the Windows® Start menu.
(5)	Windows applications key	Displays a shortcut menu for items beneath the pointer.
(6)	Arrow keys	Move the cursor around the screen.
(7)	Embedded numeric keypad keys	Can be used like the keys on an external numeric keypad.
(8)	<code>num lock</code> key	Enables numeric lock, turns on the embedded numeric keypad, and turns on the num lock light.

TouchPad



Item	Component	Function
(1)	TouchPad light	<ul style="list-style-type: none">• Blue: TouchPad is enabled.• Amber: TouchPad is disabled.
(2)	TouchPad*	Moves the pointer and selects or activates items on the screen.
(3)	TouchPad left and right buttons*	Function like the left and right buttons on an external mouse.
(4)	TouchPad on/off button	Enables/disables the TouchPad.
(5)	TouchPad scroll zone	Scrolls up or down.

*This table describes factory settings. View or change pointing device preferences by selecting **Start > Control Panel > Hardware and Sound > Mouse**.

Front components



Item	Component	Function
(1)	Power light	<ul style="list-style-type: none"> On: The computer is on. Blinking: The computer is in the Sleep state. Off: The computer is off or in Hibernation.
(2)	Battery light	<ul style="list-style-type: none"> On: A battery is charging. Blinking: A battery that is the only available power source has reached a low battery level or a critical battery level. Off: If the computer is plugged into an external power source, the light is turned off when all batteries in the computer are fully charged. If the computer is not plugged into an external power source, the light stays off until the battery reaches a low battery level.
(3)	Drive light	Blinking: The hard drive or optical drive is being accessed.
(4)	Wireless switch	Turns the wireless feature on or off, but does not create a wireless connection. NOTE: To establish a wireless connection, a wireless network must already be set up.
(5)	Wireless light	<ul style="list-style-type: none"> Blue: An integrated wireless device, such as a wireless local area network (LAN) device and/or a Bluetooth® device, is turned on. Amber: An integrated wireless device is turned off.
(6)	Consumer infrared lens	Receives a signal from a remote control device, such as the HP Remote Control.
(7)	Audio-in (microphone) jack	Connects an optional computer headset microphone, stereo array microphone, or monaural microphone.
(8)	Audio-out (headphone) jack	Produces sound when connected to optional powered stereo speakers, headphones, ear buds, a headset, or television audio.
	Audio-out (headphone) S/PDIF jack (select models only)	Produces sound when connected to optional powered stereo speakers, headphones, ear buds, a headset, or television audio.
(9)	Display lid latch	Opens the computer.

Right-side components

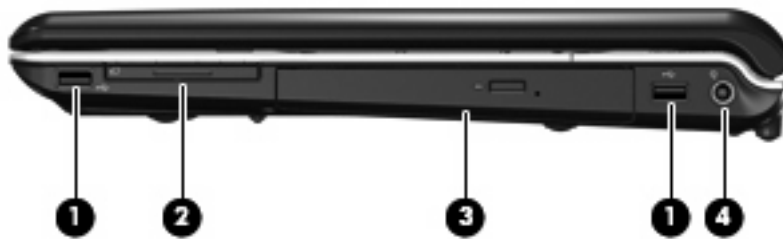

Item	Component	Function
(1)	USB ports (select models only)	Connect optional USB devices.
(2)	ExpressCard slot	Supports optional ExpressCard/54 cards.
(3)	Optical drive	Reads optical discs, and, on select models, also writes to optical discs.
(4)	Power connector	Connects an AC adapter.

Left-side components



Item	Component	Function
(1)	Security cable slot	Attaches an optional security cable to the computer. NOTE: The security cable is designed to act as a deterrent, but it may not prevent the computer from being mishandled or stolen.
(2)	S-Video-out jack	Connects an optional S-Video device such as a television, VCR, camcorder, overhead projector, or video capture card.
(3)	External monitor port	Connects an external VGA monitor or projector.
(4)	Expansion port 3	Connects the computer to an optional docking device or expansion product. NOTE: The computer has only one expansion port. The term <i>expansion port 3</i> describes the type of expansion port.
(5)	RJ-45 (network) jack	Connects a network cable. NOTE: On select computer models, the network jack provides Gigabit Ethernet functionality.
(6)	RJ-11 (modem) jack	Connects a modem cable.

Item	Component	Function
(7)	HDMI port (select models only)	Connects an optional video or audio device such as a high-definition television, set-top box, DVD player, or any compatible digital or audio device.
(8)	USB ports (1 or 2, depending on computer model)	Connect optional USB devices. NOTE: Depending on your computer model, the computer may include an HDMI port or a USB port.
(9)	1394 port (select models only)	Connects an optional IEEE 1394 or 1394a device, such as a camcorder.
(10)	Digital Media Slot light (select models only)	On: A digital card is being accessed.
(11)	Digital Media Slot (select models only)	Supports the following optional digital card formats: <ul style="list-style-type: none"> • Memory Stick (MS) • Memory Stick Pro (MSP) • MultiMediaCard (MMC) • Secure Digital Input/Output (SD I/O) • Secure Digital (SD) Memory Card • xD-Picture Card (XD) • xD-Picture Card (XD) Type H • xD-Picture Card (XD) Type M

Bottom components

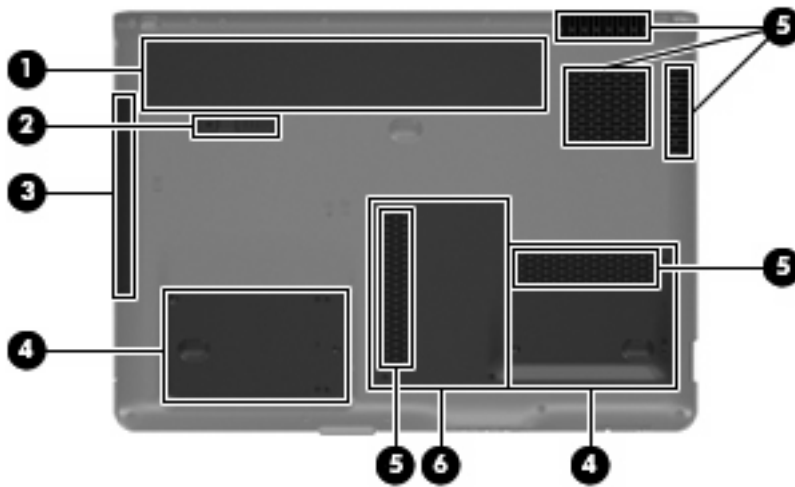

Item	Component	Function
(1)	Battery bay	Holds the battery.
(2)	Battery release latch	Releases the battery from the battery bay.
(3)	Optical drive	Reads optical discs, and, on select models, also writes to optical discs.
(4)	Secondary hard drive bay	Holds an optional secondary hard drive.
	Primary hard drive bay	Hold the primary hard drive.
(5)	Vents (5)	Enable airflow to cool internal components. NOTE: The computer fan starts up automatically to cool internal components and prevent overheating. It is normal for the internal fan to cycle on and off during routine operation.
(6)	Memory/WLAN module compartment	Contains the memory module slots, the WLAN module slot, and the RTC battery. CAUTION: To prevent an unresponsive system, replace the wireless module only with a wireless module authorized for use in the computer by the governmental agency that regulates wireless devices in your country or region. If you replace the module and then receive a warning message, remove the module to restore computer functionality, and then contact technical support through Help and Support.

3 Illustrated parts catalog

Serial number location

When ordering parts or requesting information, provide the computer serial number and model number located on the bottom of the computer.

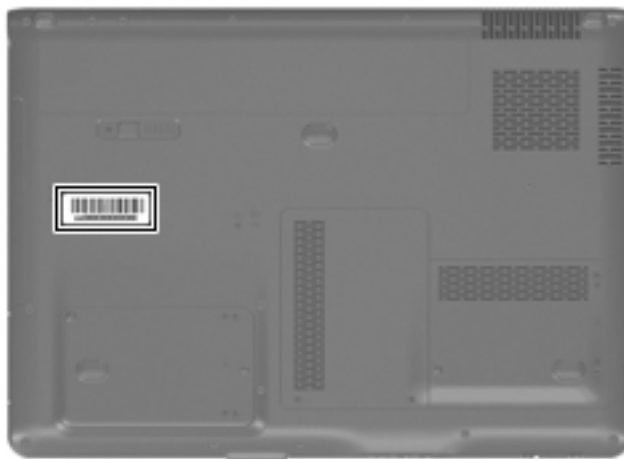

Computer major components

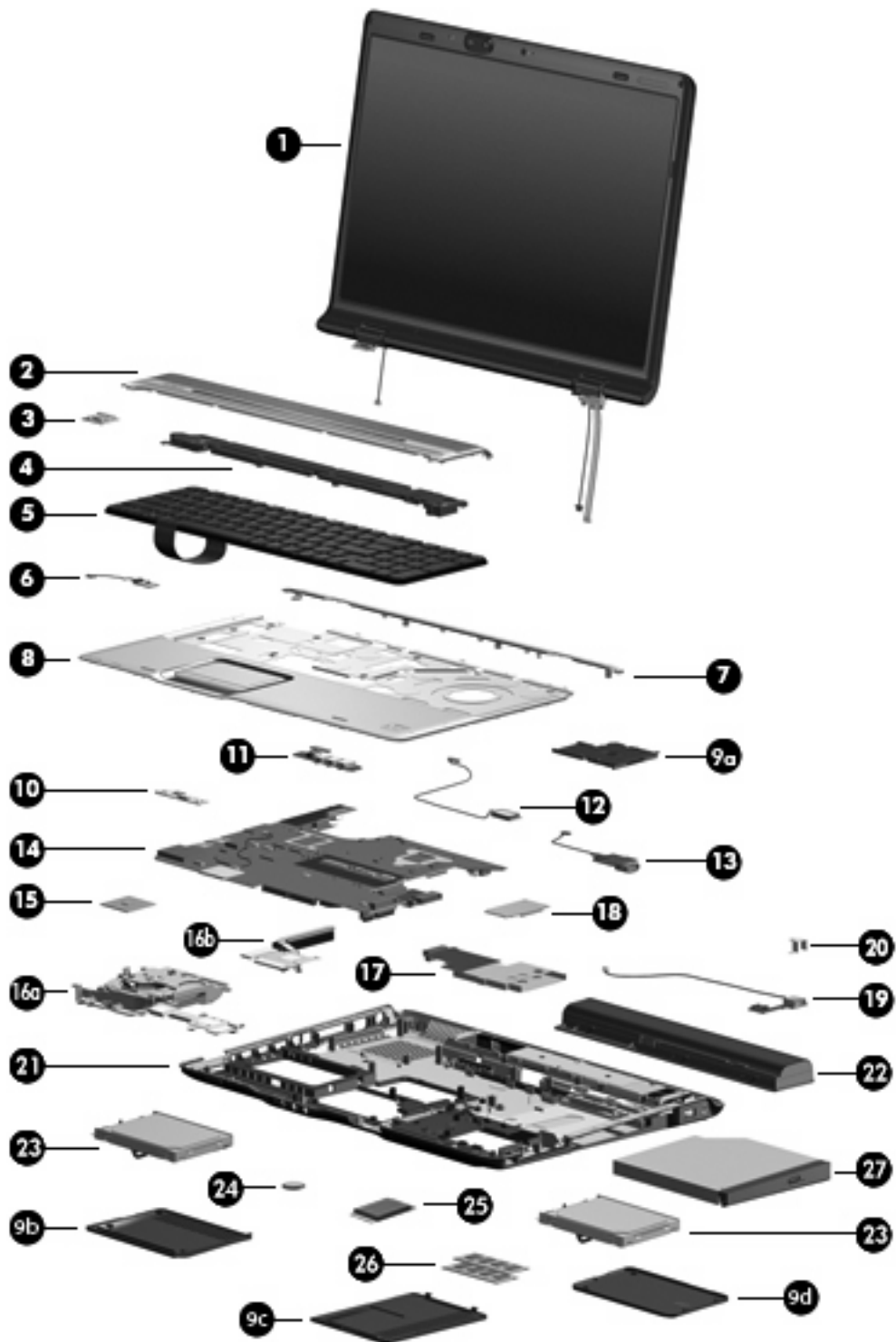

Item	Description	Spare part number
(1)	Display assemblies (include wireless antenna transceivers and cables)	

Item	Description	Spare part number
	For use only with computer models equipped with a camera	
	17.0-inch, SXGA+, TFT, single Lamp with BrightView	447990-001
	17.0-inch, WXGA+, TFT, single Lamp with BrightView	447989-001
	For use only with computer models not equipped with a camera	
	17.0-inch, SXGA+, TFT, Single Lamp with BrightView	447993-001
	17.0-inch, WXGA+, TFT, Single Lamp with BrightView	447992-001
	NOTE: See Display assembly components on page 21 for more information on display assembly spare part numbers.	
(2)	Switch cover (includes LED board and LED board cable)	448014-001
(3)	Power button board (includes power button board cable)	432987-001
(4)	Speaker assembly	432994-001
(5)	Keyboards (include keyboard cable)	
	Belgium	441541-A41
	Denmark, Finland, Norway, and Sweden	441541-DH1
	France	441541-051
	French Canada	441541-121
	Germany	441541-041
	Greece	441541-151
	Israel	441541-BB1
	Italy	441541-061
	Japan	441541-291
	Korea	441541-AD1
	Latin America	441541-161
	The Netherlands and Europe	441541-B31
	Portugal	441541-131
	Russia	441541-251
	Saudi Arabia	441541-171
	Spain	441541-071
	Switzerland	441541-111
	Thailand	441541-281
	Turkey	441541-141
	The United Kingdom	441541-031
	The United States	441541-001
(6)	Display switch module (includes display switch module cable)	448435-001

Item	Description	Spare part number
(7)	Top cover trim	432978-001
(8)	Top covers	
	For use only with computer models equipped with a fingerprint reader (includes TouchPad, TouchPad cable, fingerprint reader board, and fingerprint reader board cable)	448011-001
	For use only with computer models not equipped with a fingerprint reader (includes TouchPad and TouchPad cable)	448010-001
	Fingerprint reader board (not illustrated; includes fingerprint reader board cable)	448012-001
	Plastics Kit (see Plastics Kit on page 23 for more Plastics Kit component information)	448009-001
(9a)	ExpressCard slot bezel	
(9b)	Left hard drive cover (includes 2 captive screws, secured by C-clips)	
(9c)	Memory/WLAN module compartment cover (includes 2 captive screws, secured by C-clips)	
(9d)	Right hard drive cover (includes 2 captive screws, secured by C-clips)	
(10)	Wireless switch board (includes wireless switch board cable)	432991-001
(11)	Audio board (includes audio board cable)	449763-001
(12)	Bluetooth module (includes Bluetooth module cable)	412766-002
(13)	Front USB board (includes front USB board cable)	449762-001
(14)	System board (includes modem module cable and hard drive thermal pads)	447984-001
(15)	Processors (include thermal material)	
	Intel Core Duo T7300 (2.0-GHz, 4 MB of L2 cache, 800-MHz FSB)	447985-001
	Intel Core Duo T7300 (2.0-GHz, 4 MB of L2 cache, 800-MHz FSB)	446478-001
	Intel Core Duo T7100 (1.8-GHz, 2 MB of L2 cache, 800-MHz FSB)	446479-001
(16a)	Fan/heat sink assembly (includes heat sink and thermal material)	448016-001
(16b)	Heat sink (included with the fan/heat sink assembly)	
(17)	ExpressCard assembly	432988-001
(18)	Optical drive connector board	432992-001
		448436-001
(19)	Rear USB board	448437-001
(20)	Power connector bracket	432985-001
(21)	Base enclosures (include wireless on/off switch, power connector, power connector cable, and rear USB board cable)	
	For use only with computer models equipped with a fingerprint reader	448310-001
	For use only with computer models not equipped with a fingerprint reader	448311-001
	Rubber Feet Kit (not illustrated; includes computer feet and display bezel rubber screw covers)	448017-001
(22)	Batteries	
	8-cell, 2.55-Ah	434674-001

Item	Description	Spare part number
	8-cell, 2.20-Ah	448007-001
(23)	Hard drives (include hard drive bracket)	
	200-GB, 4200-rpm	441424-001
	160-GB, 5400-rpm	438485-001
	120-GB, 5400-rpm	446498-001
	100-GB, 7200-rpm	441540-001
	80-GB, 5400-rpm	446497-001
	Miscellaneous hard drive kits for use only in Asia Pacific countries or regions (not illustrated)	
	Hardware Kit	448304-001
	Hard drive bracket rails	448305-001
	Hard drive screws	448306-001
	Hard drive connector	448307-001
(24)	RTC battery (includes 2-sided tape)	448013-001
(25)	WLAN modules	
	Intel 802.11a/b/g/n WLAN modules	
	For use in Antigua & Barbuda, Argentina, Aruba, the Bahamas, Barbados, Bermuda, Brunei, Canada, the Cayman Islands, Chile, Colombia, Costa Rica, the Dominican Republic, Ecuador, El Salvador, Guam, Guatemala, Haiti, Honduras, Hong Kong, India, Indonesia, Malaysia, Mexico, Panama, Paraguay, Peru, Saudi Arabia, Taiwan, Uruguay, the United States, Venezuela, and Vietnam	441086-001
	For use in Austria, Azerbaijan, Bahrain, Belgium, Brazil, Bulgaria, Croatia, Cyprus, the Czech Republic, Denmark, Egypt, Estonia, Finland, France, Georgia, Germany, Greece, Hungary, Iceland, Ireland, Israel, Italy, Latvia, Lebanon, Liechtenstein, Lithuania, Luxembourg, Malta, Monaco, the Netherlands, Norway, Oman, the Philippines, Poland, Portugal, Qatar, Romania, Russia, Serbia and Montenegro, Singapore, Slovakia, Slovenia, South Africa, Spain, Sri Lanka, Sweden, Switzerland, Turkey, Ukraine, the United Kingdom, and Uzbekistan	441087-002
	For use in Australia, New Zealand, Pakistan, the People's Republic of China, and South Korea	441088-003
	For use in Japan	441089-291
	Broadcom 802.11a/b/g WLAN modules	
	For use in Antigua & Barbuda, Argentina, Australia, the Bahamas, Barbados, Brunei, Canada, Chile, the Dominican Republic, Guam, Guatemala, Hong Kong, India, Indonesia, Malaysia, Mexico, New Zealand, Panama, Paraguay, Saudi Arabia, Taiwan, the United States, and Vietnam	407674-001
	For use in Aruba, Austria, Azerbaijan, Bahrain, Belgium, Bermuda, Brazil, Bulgaria, the Cayman Islands, Colombia, Croatia, Cyprus, the Czech Republic, Denmark, Egypt, El Salvador, Estonia, Finland, France, Georgia, Germany, Greece, Hungary, Iceland, Ireland, Italy, Jordan, Latvia, Lebanon, Liechtenstein, Lithuania, Luxembourg, Malta, Monaco, the Netherlands, Norway, Oman, the Philippines, Poland, Portugal, Romania, Russia, Serbia and Montenegro, Singapore, Slovakia, Slovenia, South Africa, Spain, Sri Lanka, Sweden, Switzerland, Turkey, the United Kingdom, and Uzbekistan	407674-002
	For use in Ecuador, Haiti, Honduras, Pakistan, Peru, the People's Republic of China, Qatar, South Korea, Uruguay, and Venezuela	407674-003

Item	Description	Spare part number
	For use in Japan	407674-291
	Broadcom 802.11b/g WLAN module for use in Thailand	407674-004
(26)	Memory modules (667-MHz, PC2-5300, 1-DIMM)	
	2048-MB	448003-001
	1024-MB	446495-001
	512-MB	446494-001
(27)	Optical drives (include bezel and bracket)	
	DVD±RW and CD-RW Super Multi Double-Layer Combo Drive with LightScribe	448005-001
	DVD±RW and CD-RW Super Multi Double-Layer Combo Drive	448004-001
	Cable Kit (not illustrated; see Cable Kit on page 24 for more Cable Kit component information)	448015-001

Display assembly components

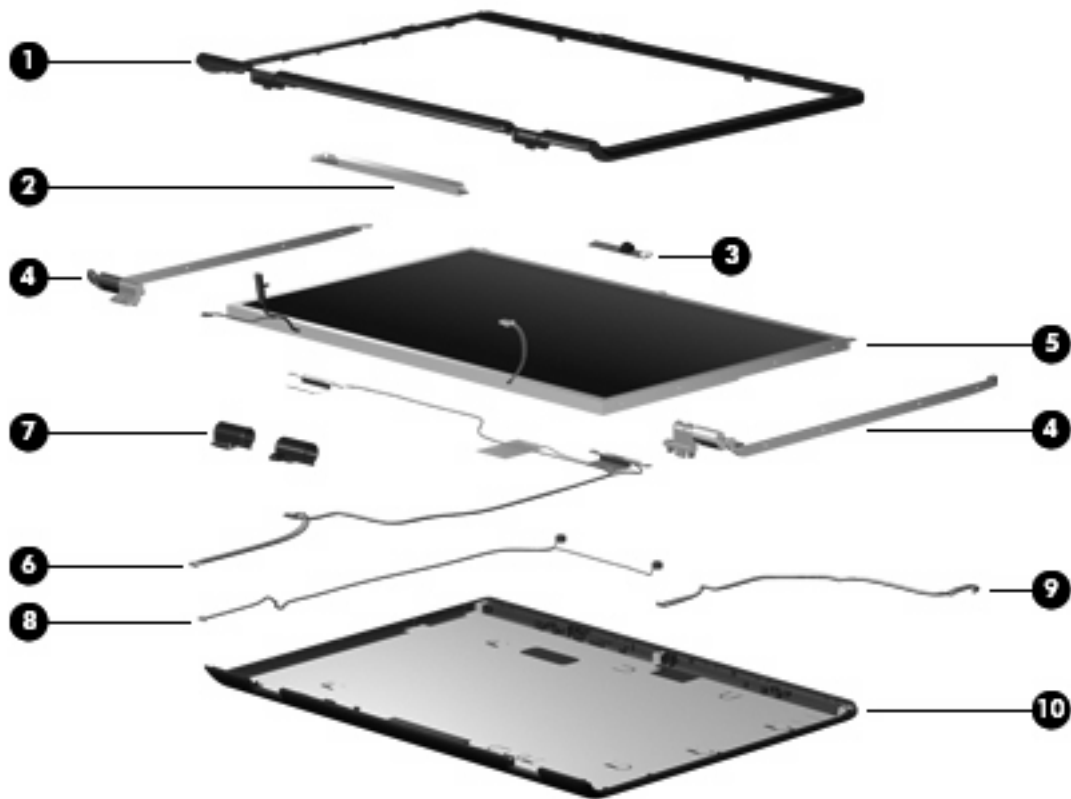

Item	Description	Spare part number
(1)	Display bezels	
	For use only with computer models equipped with a camera	447997-001
	For use only with computer models not equipped with a camera	447996-001
(2)	Display inverter (includes Mylar shield)	431391-001
(3)	Camera module (includes 2-sided tape)	448002-001
(4)	Display Hinge Kit (includes left and right display hinges)	432963-001
(5)	Display panels (include display panel cable)	
	17.0-inch, SXGA+ BrightView	447987-001
	17.0-inch, WXGA+ BrightView	447986-001
(6)	Wireless antenna transceivers and cables	
	For use only with computer models equipped with an 802.11a/b/g/n WLAN module	448313-001
	For use only with computer models equipped with an 802.11a/b/g and 802.11b/g WLAN module	448312-001
(7)	Display hinge covers	432965-001
(8)	Microphones	432961-001
(9)	Display Cable Kit (includes camera module cable)	432962-001

Item	Description	Spare part number
(10)	Display enclosure (includes logo and WLAN wireless antenna transceivers and cables)	448000-001
	Display Screw Kit (not illustrated)	432967-001

Plastics Kit



Item	Description	Spare part number
	Plastics Kit	448009-001
(1)	ExpressCard slot bezel	
(2)	Left hard drive cover (includes 2 captive screws, secured by C-clips)	
(3)	Memory/WLAN module compartment cover (includes 2 captive screws, secured by C-clips)	
(4)	Right hard drive cover (includes 2 captive screws, secured by C-clips)	
	USB port cover (not illustrated; for use only with computer models not equipped with a fingerprint reader)	

Cable Kit



Item	Description	Spare part number
	Cable Kit	448015-001
(1)	Bluetooth module cable	
(2)	Front USB board cable	
(3)	Fingerprint reader board cable	
(4)	Rear USB board cable	

Mass storage devices

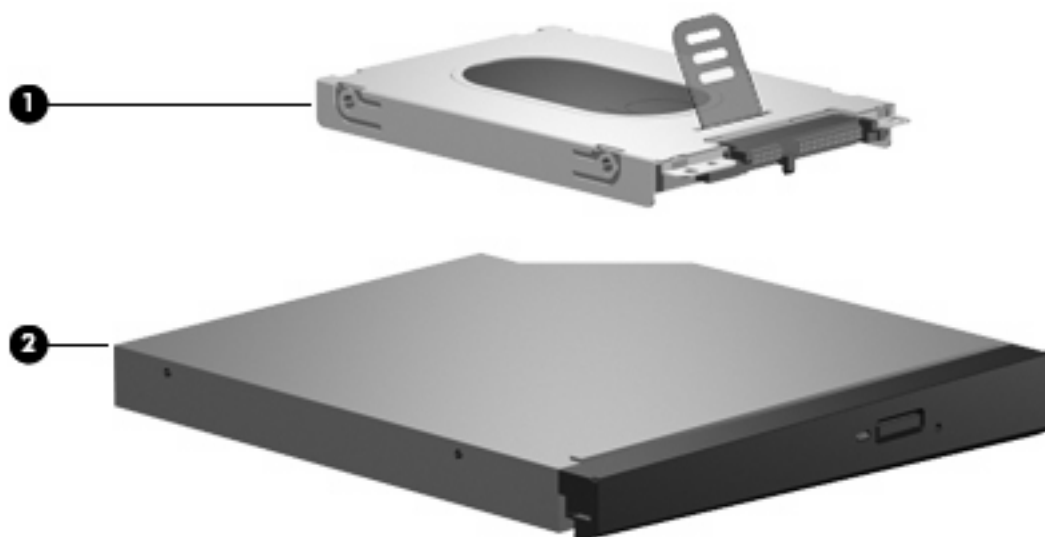

Item	Description	Spare part number
(1)	Hard drives (include hard drive bracket)	
	200-GB, 4200-rpm	441424-001
	160-GB, 5400-rpm	438485-001
	120-GB, 5400-rpm	446498-001
	100-GB, 7200-rpm	441540-001
	80-GB, 5400-rpm	446497-001
(2)	Optical drives (include bezel and bracket)	
	DVD±RW and CD-RW Super Multi Double-Layer Combo Drive with LightScribe	448005-001
	DVD±RW and CD-RW Super Multi Double-Layer Combo Drive	448004-001

Miscellaneous parts

Description	Spare part number
65W AC adapter	402018-001
ATSC/NTSC TV tuner antenna	439131-001
ATSC/NTSC/PAL TV tuner	439130-001
Composite video cable	407939-001
DVB-T tuner	412175-001
DVB-T antenna adapter	412176-001
ExpressCard Kit (includes software CD)	445170-001
HP backpack	405527-001
HP carrying case	418162-001
HP Remote Control	435743-001
Infrared emitter with cable	439129-001
Optical wired mouse	436238-001
RF input adapter cable (without ferrite)	407940-001
USB digital drive	364727-002
Vista remote control (fits into ExpressCard slot)	439128-001
Vista remote control (does not fit into ExpressCard slot)	439254-001
Wired headset	371693-001
Wireless laser mouse (includes cable adapter)	430958-001
Power cords:	
Argentina	394279-D01
Australia and New Zealand	394279-011
Belgium, Europe, Finland, France, Germany, Greece, the Netherlands, Norway, Portugal, Spain, and Sweden	394279-021
Canada, French Canada, Latin America, Thailand, and the United States	394279-001
Denmark	394279-081
India	394279-D61
Israel	394279-BB1
Italy	394279-061
Japan	394279-291
Korea	394279-AD1
The People's Republic of China	394279-AA1
Switzerland	394279-111

Description	Spare part number
The United Kingdom and Hong Kong	394279-031
Screw Kit	432983-001
<ul style="list-style-type: none"> • Phillips PM3.0×3.0 screw • Phillips PM2.5×10.0 screw • Phillips PM2.5×7.0 screw • Phillips PM2.5×5.0 screw • Phillips PM2.5×4.0 screw • Phillips PM2.0×6.0 screw • Phillips PM2.0×5.0 captive screw • Phillips PM2.0×4.0 screw • Phillips PM2.0×3.0 screw 	

Sequential part number listing

Spare part number	Description
371693-001	Wired headset with volume control
394279-001	Power cord for use in the United States
394279-011	Power cord for use in Australia
394279-021	Power cord for use in Europe
394279-031	Power cord for use in the United Kingdom
394279-061	Power cord for use in Italy
394279-081	Power cord for use in Denmark
394279-111	Power cord for use in Switzerland
394279-291	Power cord for use in Japan
394279-AA1	Power cord for use in the People's Republic of China
394279-AD1	Power cord for use in Korea
394279-BB1	Power cord for use in Israel
394279-D01	Power cord for use in Argentina
394279-D61	Power cord for use in India
402018-001	65-watt AC adapter
405527-001	HP backpack
407674-001	Broadcom 802.11a/b/g WLAN module for use in Antigua & Barbuda, Argentina, Australia, the Bahamas, Barbados, Brunei, Canada, Chile, the Dominican Republic, Guam, Guatemala, Hong Kong, India, Indonesia, Malaysia, Mexico, New Zealand, Panama, Paraguay, Saudi Arabia, Taiwan, the United States, and Vietnam

Spare part number	Description
407674-002	Broadcom 802.11a/b/g WLAN module for use in Aruba, Austria, Azerbaijan, Bahrain, Belgium, Bermuda, Brazil, Bulgaria, the Cayman Islands, Colombia, Croatia, Cyprus, the Czech Republic, Denmark, Egypt, El Salvador, Estonia, Finland, France, Georgia, Germany, Greece, Hungary, Iceland, Ireland, Italy, Jordan, Latvia, Lebanon, Liechtenstein, Lithuania, Luxembourg, Malta, Monaco, the Netherlands, Norway, Oman, the Philippines, Poland, Portugal, Romania, Russia, Serbia and Montenegro, Singapore, Slovakia, Slovenia, South Africa, Spain, Sri Lanka, Sweden, Switzerland, Turkey, the United Kingdom, and Uzbekistan
407674-003	Broadcom 802.11a/b/g WLAN module for use in Ecuador, Haiti, Honduras, Pakistan, Peru, the People's Republic of China, Qatar, South Korea, Uruguay, and Venezuela
407674-004	Broadcom 802.11b/g WLAN module for use in Thailand
407674-291	Broadcom 802.11a/b/g WLAN module for use in Japan
407939-001	Composite video cable
407940-001	RF input adapter cable (without ferrite)
412175-001	DVB-T tuner
412176-001	DVB-T antenna adapter
412766-002	Bluetooth module (includes Bluetooth module cable)
430958-001	Wireless laser mouse (includes cable adapter)
431391-001	Display inverter (includes Mylar shield)
432961-001	Microphone
432962-001	Display Cable Kit
432963-001	Display Hinge Kit (includes left and right display hinges)
432965-001	Display hinge covers
432967-001	Display Screw Kit
432978-001	Top cover trim
432983-001	Screw Kit
432985-001	Power connector bracket
432987-001	Power button board (includes power button board cable)
432988-001	ExpressCard assembly
432991-001	Wireless switch board (includes wireless switch board cable)
432992-001	Optical drive connector board
432994-001	Speaker assembly
434674-001	8-cell, 2.55-Ah battery
436238-001	Optical wired mouse
438485-001	160-GB, 5400-rpm hard drive (includes hard drive bracket)
439128-001	Vista remote control (fits inside ExpressCard slot)
439129-001	Infrared emitter with cable
439130-001	ATSC/NTSC/PAL TV tuner

Spare part number	Description
439131-001	ATSC/NTSC TV tuner antenna
439254-001	Vista remote control (does not fit inside ExpressCard slot)
441086-001	Intel 802.11a/b/g/n WLAN module for use in Antigua & Barbuda, Argentina, Aruba, the Bahamas, Barbados, Bermuda, Brunei, Canada, the Cayman Islands, Chile, Colombia, Costa Rica, the Dominican Republic, Ecuador, El Salvador, Guam, Guatemala, Haiti, Honduras, Hong Kong, India, Indonesia, Malaysia, Mexico, Panama, Paraguay, Peru, Saudi Arabia, Taiwan, Uruguay, the United States, Venezuela, and Vietnam
441087-002	Intel 802.11a/b/g/n WLAN module for use in Austria, Azerbaijan, Bahrain, Belgium, Brazil, Bulgaria, Croatia, Cyprus, the Czech Republic, Denmark, Egypt, Estonia, Finland, France, Georgia, Germany, Greece, Hungary, Iceland, Ireland, Israel, Italy, Latvia, Lebanon, Liechtenstein, Lithuania, Luxembourg, Malta, Monaco, the Netherlands, Norway, Oman, the Philippines, Poland, Portugal, Qatar, Romania, Russia, Serbia and Montenegro, Singapore, Slovakia, Slovenia, South Africa, Spain, Sri Lanka, Sweden, Switzerland, Turkey, Ukraine, the United Kingdom, and Uzbekistan
441088-003	Intel 802.11a/b/g/n WLAN module for use in Australia, New Zealand, Pakistan, the People's Republic of China, and South Korea
441089-291	Intel 802.11a/b/g/n WLAN module for use in Japan
441424-001	200-GB, 4200-rpm hard drive (includes hard drive bracket)
441540-001	100-GB, 7200-rpm hard drive (includes hard drive bracket)
441541-001	Keyboard for use in the United States
441541-031	Keyboard for use in the United Kingdom
441541-041	Keyboard for use in Germany
441541-051	Keyboard for use in France
441541-061	Keyboard for use in Italy
441541-071	Keyboard for use in Spain
441541-111	Keyboard for use in Switzerland
441541-121	Keyboard for use in French Canada
441541-131	Keyboard for use in Portugal
441541-141	Keyboard for use in Turkey
441541-151	Keyboard for use in Greece
441541-161	Keyboard for use in Latin America
441541-171	Keyboard for use in Saudi Arabia
441541-251	Keyboard for use in Russia
441541-281	Keyboard for use in Thailand
441541-291	Keyboard for use in Japan
441541-A41	Keyboard for use in Belgium
441541-AD1	Keyboard for use in Korea
441541-B31	Keyboard for in the Netherlands and Europe
441541-BB1	Keyboard for use in Israel
441541-DH1	Keyboard for use in Denmark, Finland, Norway, and Sweden

Spare part number	Description
445170-001	ExpressCard Kit (includes software CD)
446478-001	Intel Core Duo T7300 2.0-GHz processor (4 MB of L2 cache, 800-MHz FSB; includes thermal material)
446479-001	Intel Core Duo T7100 1.8-GHz processor (1.8-GHz, 2 MB of L2 cache, 800-MHz FSB; includes thermal material)
446494-001	512-MB memory module (667-MHz, PC2-5300, 1-DIMM)
446495-001	1024-MB memory module (667-MHz, PC2-5300, 1-DIMM)
446497-001	80-GB, 5400-rpm hard drive (includes hard drive bracket)
446498-001	120-GB, 5400-rpm hard drive (includes hard drive bracket)
447984-001	System board (includes modem module cable and hard drive thermal pads)
447985-001	Intel Core Duo T7500 2.2-GHz processor (4 MB of L2 cache, 800-MHz FSB; includes thermal material)
447986-001	17.0-inch, WXGA+, TFT, single lamp, BrightView display panel (includes display panel cable)
447987-001	17.0-inch, SXGA+, TFT, single lamp, BrightView display panel (includes display panel cable)
447989-001	17.0-inch, WXGA+, TFT, single lamp, BrightView display assembly for use only with computer models equipped with a camera (includes wireless antenna transceivers and cables)
447990-001	17.0-inch, SXGA+, TFT, single lamp, BrightView display assembly for use only with computer models equipped with a camera (includes wireless antenna transceivers and cables)
447992-001	17.0-inch, WXGA+, TFT, single lamp, BrightView display assembly for use only with computer models not equipped with a camera (includes wireless antenna transceivers and cables)
447993-001	17.0-inch, SXGA+, TFT, single lamp, BrightView display assembly for use only with computer models not equipped with a camera (includes wireless antenna transceivers and cables)
447996-001	Display bezel for use only with computer models not equipped with a camera
447997-001	Display bezel for use only with computer models equipped with a camera
448000-001	Display enclosure (includes logo and WLAN wireless antenna transceivers and cables)
448002-001	Camera module (includes 2-sided tape)
448003-001	2048-MB memory module (667-MHz, PC2-5300, 1-DIMM)
448004-001	DVD±RW and CD-RW Super Multi Double-Layer Combo Drive (includes bezel and bracket)
448005-001	DVD±RW and CD-RW Super Multi Double-Layer Combo Drive with LightScribe (includes bezel and bracket)
448007-001	8-cell, 2.20-Ah battery
448009-001	Plastics Kit (see Plastics Kit on page 23 for more Plastics Kit component information)
448010-001	Top cover for use only with computer models not equipped with a fingerprint reader (includes TouchPad and TouchPad cable)
448011-001	Top cover for use only with computer models equipped with a fingerprint reader (includes TouchPad, TouchPad cable, fingerprint reader board, and fingerprint reader board cable)
448012-001	Fingerprint reader board (not illustrated; includes fingerprint reader board cable)
448013-001	RTC battery (includes 2-sided tape)
448014-001	Switch cover (includes LED board and LED board cable)
448015-001	Cable Kit (see Cable Kit on page 24 for more Cable Kit component information)

Spare part number	Description
448016-001	Fan/heat sink assembly (includes heat sink and thermal material)
448017-001	Rubber Feet Kit (includes computer feet and display bezel rubber screw covers)
448304-001	Hardware Kit
448305-001	Hard drive bracket rails
448306-001	Hard drive screws
448307-001	Hard drive connector
448310-001	Base enclosure for use only with computer models equipped with a fingerprint reader (includes wireless on/off switch, power connector, power connector cable, and rear USB board cable)
448311-001	Base enclosure for use only with computer models not equipped with a fingerprint reader (includes wireless on/off switch, power connector, power connector cable, and rear USB board cable)
448312-001	Wireless antenna transceivers and cables for use only with computer models equipped with an 802.11a/b/g and 802.11b/g WLAN module
448313-001	Wireless antenna transceivers and cables for use only with computer models equipped with an 802.11a/b/g/n WLAN module
448435-001	Display switch module (includes display switch module cable)
448436-001	Optical drive connector board
448437-001	Rear USB board
449762-001	Front USB board (includes front USB board cable)
449763-001	Audio board (includes audio board cable)

4 Removal and replacement procedures

Preliminary replacement requirements

Tools required

You will need the following tools to complete the removal and replacement procedures:

- Magnetic screwdriver
- Phillips PO and P1 screwdrivers
- Flat-bladed screwdriver

Service considerations

The following sections include some of the considerations that you must keep in mind during disassembly and assembly procedures.

 **NOTE:** As you remove each subassembly from the computer, place the subassembly (and all accompanying screws) away from the work area to prevent damage.

Plastic parts

Using excessive force during disassembly and reassembly can damage plastic parts. Use care when handling the plastic parts. Apply pressure only at the points designated in the maintenance instructions.

Cables and connectors

-
- △ **CAUTION:** When servicing the computer, be sure that cables are placed in their proper locations during the reassembly process. Improper cable placement can damage the computer.
-

Cables must be handled with extreme care to avoid damage. Apply only the tension required to unseat or seat the cables during removal and insertion. Handle cables by the connector whenever possible. In all cases, avoid bending, twisting, or tearing cables. Be sure that cables are routed in such a way that they cannot be caught or snagged by parts being removed or replaced. Handle flex cables with extreme care; these cables tear easily.

Drive handling

-
- △ **CAUTION:** Drives are fragile components that must be handled with care. To prevent damage to the computer, damage to a drive, or loss of information, observe these precautions:
-

Before removing or inserting a hard drive, shut down the computer. If you are unsure whether the computer is off or in Hibernation, turn the computer on, and then shut it down through the operating system.

Before handling a drive, be sure that you are discharged of static electricity. While handling a drive, avoid touching the connector.

Before removing a diskette drive or optical drive, be sure that a diskette or disc is not in the drive and be sure that the optical drive tray is closed.

Handle drives on surfaces covered with at least one inch of shock-proof foam.

Avoid dropping drives from any height onto any surface.

After removing a hard drive, an optical drive, or a diskette drive, place it in a static-proof bag.

Avoid exposing a hard drive to products that have magnetic fields, such as monitors or speakers.

Avoid exposing a drive to temperature extremes or liquids.

If a drive must be mailed, place the drive in a bubble pack mailer or other suitable form of protective packaging and label the package "FRAGILE."

Grounding guidelines

Electrostatic discharge damage

Electronic components are sensitive to electrostatic discharge (ESD). Circuitry design and structure determine the degree of sensitivity. Networks built into many integrated circuits provide some protection, but in many cases, ESD contains enough power to alter device parameters or melt silicon junctions.

A discharge of static electricity from a finger or other conductor can destroy static-sensitive devices or microcircuitry. Even if the spark is neither felt nor heard, damage may have occurred.

An electronic device exposed to ESD may not be affected at all and can work perfectly throughout a normal cycle. Or the device may function normally for a while, then degrade in the internal layers, reducing its life expectancy.

△ **CAUTION:** To prevent damage to the computer when you are removing or installing internal components, observe these precautions:

Keep components in their electrostatic-safe containers until you are ready to install them.

Use nonmagnetic tools.

Before touching an electronic component, discharge static electricity by using the guidelines described in this section.

Avoid touching pins, leads, and circuitry. Handle electronic components as little as possible.

If you remove a component, place it in an electrostatic-safe container.

The following table shows how humidity affects the electrostatic voltage levels generated by different activities.

△ **CAUTION:** A product can be degraded by as little as 700 V.

Typical electrostatic voltage levels			
Event	Relative humidity		
	10%	40%	55%
Walking across carpet	35,000 V	15,000 V	7,500 V
Walking across vinyl floor	12,000 V	5,000 V	3,000 V
Motions of bench worker	6,000 V	800 V	400 V
Removing DIPS from plastic tube	2,000 V	700 V	400 V
Removing DIPS from vinyl tray	11,500 V	4,000 V	2,000 V
Removing DIPS from Styrofoam	14,500 V	5,000 V	3,500 V
Removing bubble pack from PCB	26,500 V	20,000 V	7,000 V
Packing PCBs in foam-lined box	21,000 V	11,000 V	5,000 V

Packaging and transporting guidelines

Follow these grounding guidelines when packaging and transporting equipment:

- To avoid hand contact, transport products in static-safe tubes, bags, or boxes.
- Protect ESD-sensitive parts and assemblies with conductive or approved containers or packaging.
- Keep ESD-sensitive parts in their containers until the parts arrive at static-free workstations.
- Place items on a grounded surface before removing items from their containers.
- Always be properly grounded when touching a component or assembly.
- Store reusable ESD-sensitive parts from assemblies in protective packaging or nonconductive foam.
- Use transporters and conveyors made of antistatic belts and roller bushings. Be sure that mechanized equipment used for moving materials is wired to ground and that proper materials are selected to avoid static charging. When grounding is not possible, use an ionizer to dissipate electric charges.

Workstation guidelines

Follow these grounding workstation guidelines:

- Cover the workstation with approved static-shielding material.
- Use a wrist strap connected to a properly grounded work surface and use properly grounded tools and equipment.
- Use conductive field service tools, such as cutters, screwdrivers, and vacuums.
- When fixtures must directly contact dissipative surfaces, use fixtures made only of static-safe materials.
- Keep the work area free of nonconductive materials, such as ordinary plastic assembly aids and Styrofoam.
- Handle ESD-sensitive components, parts, and assemblies by the case or PCM laminate. Handle these items only at static-free workstations.
- Avoid contact with pins, leads, or circuitry.
- Turn off power and input signals before inserting or removing connectors or test equipment.

Equipment guidelines

Grounding equipment must include either a wrist strap or a foot strap at a grounded workstation.

- When seated, wear a wrist strap connected to a grounded system. Wrist straps are flexible straps with a minimum of one megohm $\pm 10\%$ resistance in the ground cords. To provide proper ground, wear a strap snugly against the skin at all times. On grounded mats with banana-plug connectors, use alligator clips to connect a wrist strap.
- When standing, use foot straps and a grounded floor mat. Foot straps (heel, toe, or boot straps) can be used at standing workstations and are compatible with most types of shoes or boots. On conductive floors or dissipative floor mats, use foot straps on both feet with a minimum of one megohm resistance between the operator and ground. To be effective, the conductive strips must be worn in contact with the skin.

The following grounding equipment is recommended to prevent electrostatic damage:

- Antistatic tape
- Antistatic smocks, aprons, and sleeve protectors
- Conductive bins and other assembly or soldering aids
- Nonconductive foam
- Conductive tabletop workstations with ground cords of one megohm resistance
- Static-dissipative tables or floor mats with hard ties to the ground
- Field service kits
- Static awareness labels
- Material-handling packages
- Nonconductive plastic bags, tubes, or boxes
- Metal tote boxes
- Electrostatic voltage levels and protective materials

The following table lists the shielding protection provided by antistatic bags and floor mats.

Material	Use	Voltage protection level
Antistatic plastic	Bags	1,500 V
Carbon-loaded plastic	Floor mats	7,500 V
Metallized laminate	Floor mats	5,000 V

Unknown user password

If the computer you are servicing has an unknown user password, follow these steps to clear the password.

 **NOTE:** These steps also clear CMOS.

Before disassembling the computer, follow these steps:

1. Shut down the computer. If you are unsure whether the computer is off or in Hibernation, turn the computer on, and then shut it down through the operating system.
2. Disconnect all external devices connected to the computer.
3. Disconnect the power from the computer by first unplugging the power cord from the AC outlet and then unplugging the AC adapter from the computer.
4. Remove the battery (see [Battery on page 40](#)).
5. Remove the RTC battery (see [RTC battery on page 49](#)).
6. Wait approximately 5 minutes.
7. Replace the RTC battery and reassemble the computer.
8. Connect AC power to the computer. Do not reinsert any batteries at this time.
9. Turn on the computer.

All passwords and all CMOS settings have been cleared.

Component replacement procedures

This chapter provides removal and replacement procedures.

There are as many as 107 screws, in 14 different sizes, that must be removed, replaced, or loosened when servicing the computer. Make special note of each screw size and location during removal and replacement.

Serial number

Report the computer serial number to HP when requesting information or ordering spare parts. The serial number is located on the bottom of the computer.

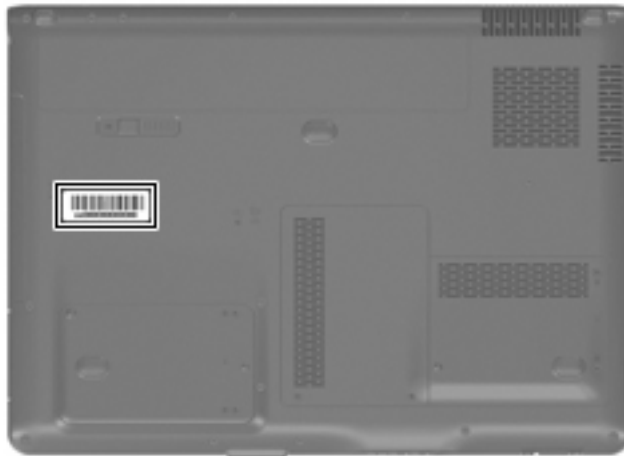

Battery

Description	Spare part number
8-cell, 2.55-Ah battery	434674-001
8-cell, 2.20-Ah battery	448007-001

Before disassembling the computer, follow these steps:

1. Shut down the computer. If you are unsure whether the computer is off or in Hibernation, turn the computer on, and then shut it down through the operating system.
2. Disconnect all external devices connected to the computer.
3. Disconnect the power from the computer by first unplugging the power cord from the AC outlet and then unplugging the AC adapter from the computer.

Remove the battery:

1. Turn the computer upside down on a flat surface.
2. Slide the battery release latch **(1)** to release the computer.
3. Pivot the battery **(2)** upward and remove it from the computer.



To insert the battery, insert the rear edge of the battery into the battery bay and pivot the front edge of the battery downward until it is seated. The battery release latch automatically locks the battery into place.

Camera module

 **NOTE:** If it has been determined that the camera module is the component that must be replaced to complete the computer repair, the display assembly does not have to be removed. Follow the procedures in this section to replace the camera module. For information on replacing the display assembly and other display assembly internal components, see [Display assembly on page 62](#).

Description	Spare part number
Camera module (includes 2-sided tape)	448002-001

Before removing the camera module, follow these steps:

1. Shut down the computer. If you are unsure whether the computer is off or in Hibernation, turn the computer on, and then shut it down through the operating system.
2. Disconnect all external devices connected to the computer.
3. Disconnect the power from the computer by first unplugging the power cord from the AC outlet and then unplugging the AC adapter from the computer.
4. Remove the battery (see [Battery on page 40](#)).

Remove the camera module:

1. Turn the computer display-side up, with the front toward you.
2. Open the computer as far as possible.
3. Remove the three rubber screw covers **(1)** on the display bezel top edge. The display rubber screw covers are included in the Display Screw Kit, spare part number 432967-001.
4. Remove the three Phillips PM2.5×8.0 screws **(2)** on the display bezel top edge.

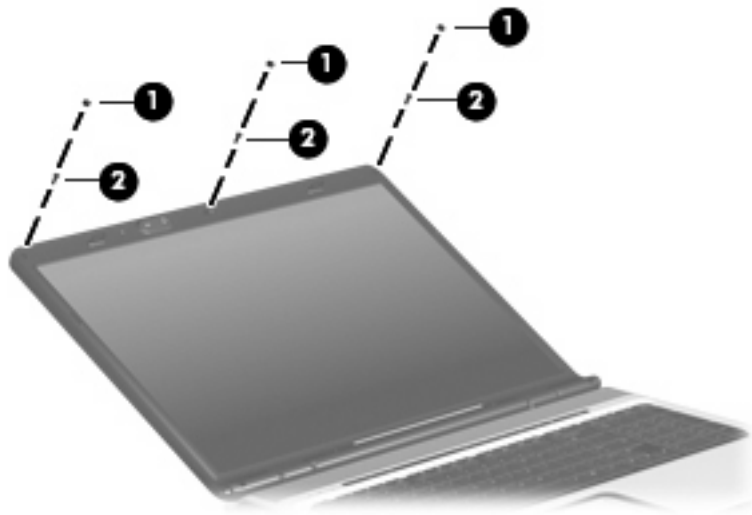

5. Flex the inside edges of the left and right sides **(1)** and the top edge **(2)** of the display bezel until the bezel disengages from the display enclosure.



6. Release the camera module **(1)** from the display enclosure as far as the camera module cable allows.
7. Disconnect the camera module cable **(2)** from the camera module.

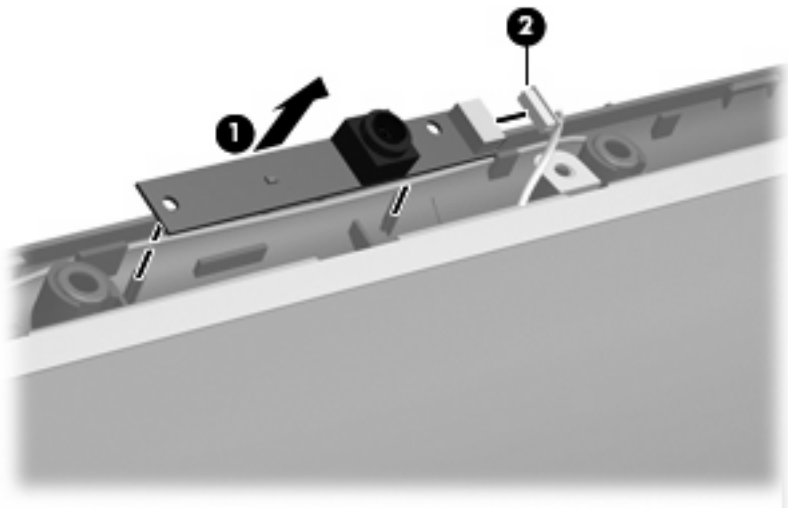

8. Remove the camera module.

Reverse this procedure to install the camera module.

Display inverter

 **NOTE:** If it has been determined that the display inverter is the component that must be replaced to complete the computer repair, the display assembly does not have to be removed. Follow the procedures in this section to replace the display inverter. For information on replacing the display assembly and other display assembly internal components, see [Display assembly on page 62](#).

Description	Spare part number
Display inverter (includes 2-sided tape)	431391-001

Before removing the display inverter, follow these steps:

1. Shut down the computer. If you are unsure whether the computer is off or in Hibernation, turn the computer on, and then shut it down through the operating system.
2. Disconnect all external devices connected to the computer.
3. Disconnect the power from the computer by first unplugging the power cord from the AC outlet and then unplugging the AC adapter from the computer.
4. Remove the battery (see [Battery on page 40](#)).

Remove the display inverter:

1. Turn the computer display-side up, with the front toward you.
2. Open the computer as far as possible.
3. Remove the two rubber screw covers **(1)** on the display bezel bottom edge. The display rubber screw covers are included in the Display Screw Kit, spare part number 432967-001.
4. Remove the two Phillips PM2.5×8.0 screws **(2)** that secure the display bezel bottom edge to the display assembly.

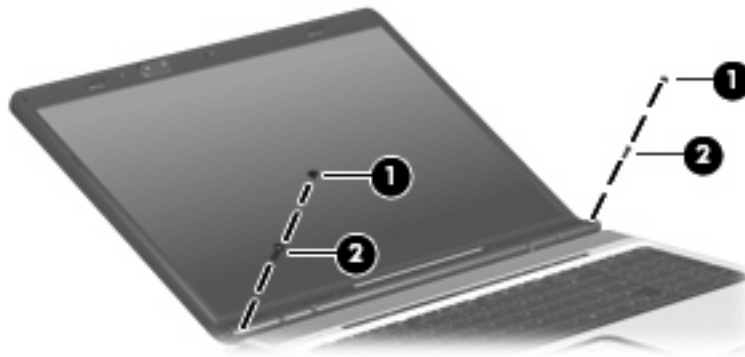

5. Flex the inside edges of the left and right sides **(1)** and the bottom edge **(2)** of the display bezel until the bezel disengages from the display enclosure.



6. Release the display inverter **(1)** as far as the display panel cable and the backlight cable allow.
7. Disconnect the display panel cable **(2)** and the backlight cable **(3)** from the display inverter.

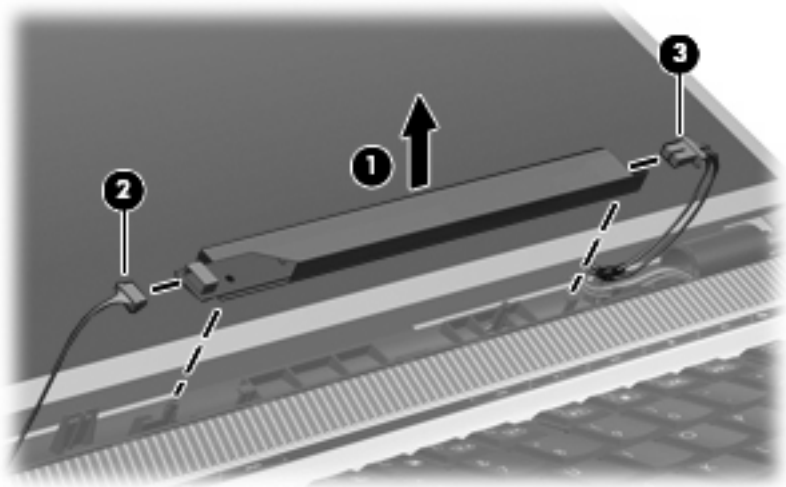

8. Remove the display inverter.

Reverse this procedure to install the display inverter.

Hard drive

 **NOTE:** All hard drive spare part kits include a hard drive bracket.

Description	Spare part number
200-GB, 4200-rpm	441424-001
160-GB, 5400-rpm	441424-001
120-GB, 5400-rpm	446498-001
100-GB, 7200-rpm	441540-001
80-GB, 5400-rpm	446497-001

Before removing the hard drive, follow these steps:

1. Shut down the computer. If you are unsure whether the computer is off or in Hibernation, turn the computer on, and then shut it down through the operating system.
2. Disconnect all external devices connected to the computer.
3. Disconnect the power from the computer by first unplugging the power cord from the AC outlet and then unplugging the AC adapter from the computer.
4. Remove the battery (see [Battery on page 40](#)).

Remove the hard drive:

1. Position the computer with the front toward you.
2. Loosen the two Phillips PM2.5×8.0 captive screws **(1)** that secure each hard drive cover to the computer.
3. Lift the right side of the hard drive cover **(2)**, swing it to left, then remove the cover. The hard drive cover is included in the Plastics Kit, spare part number 448009-001.

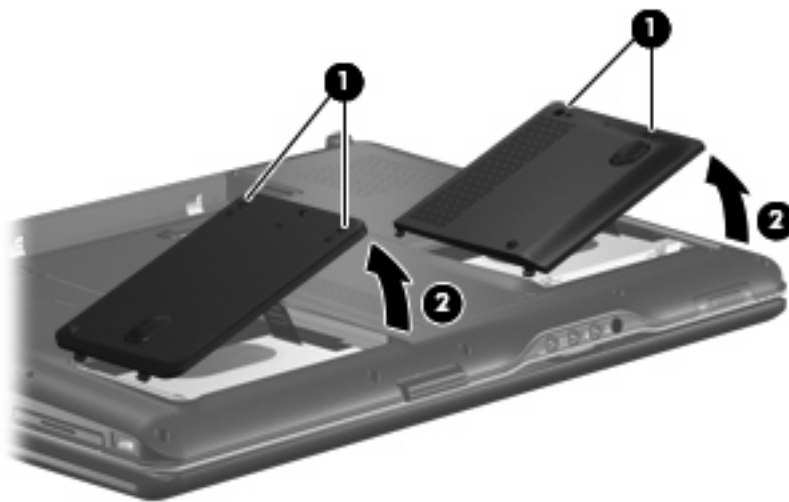

4. Use the Mylar tab **(1)** to lift the hard drive **(2)** until it disconnects from the computer.

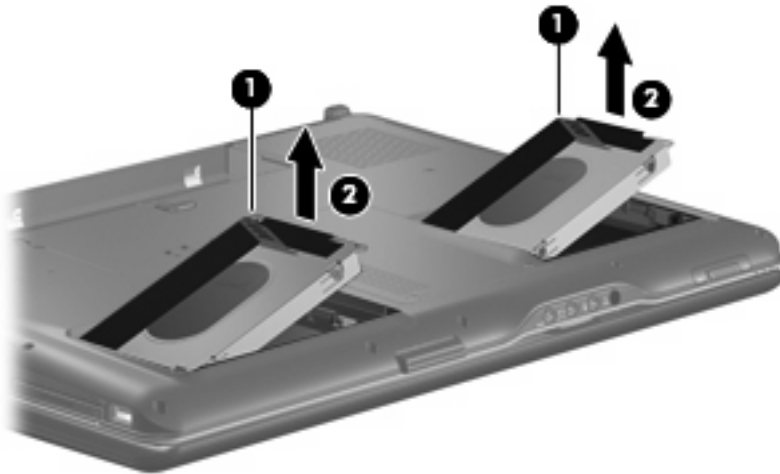

5. Remove the hard drive from the hard drive bay.
6. If it is necessary to replace the hard drive bracket, remove the four Phillips PM3.0×4.0 screws **(1)** that secure the hard drive bracket to the hard drive.
7. Lift the bracket **(2)** straight up to remove it from the hard drive.

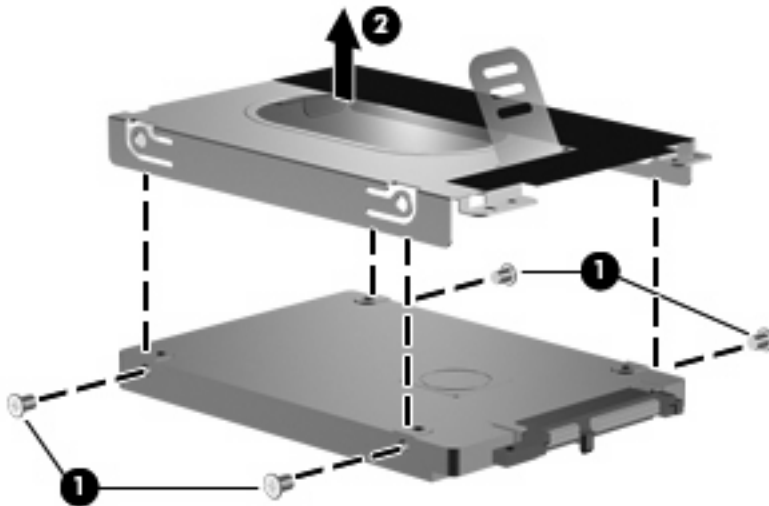

Reverse this procedure to reassemble and install the hard drive.

Computer feet

Description	Spare part number
Rubber Feet Kit (includes computer feet and display bezel rubber screw covers)	448017-001

The computer feet are adhesive-backed rubber pads. The feet attach to the base enclosure in the locations illustrated below.

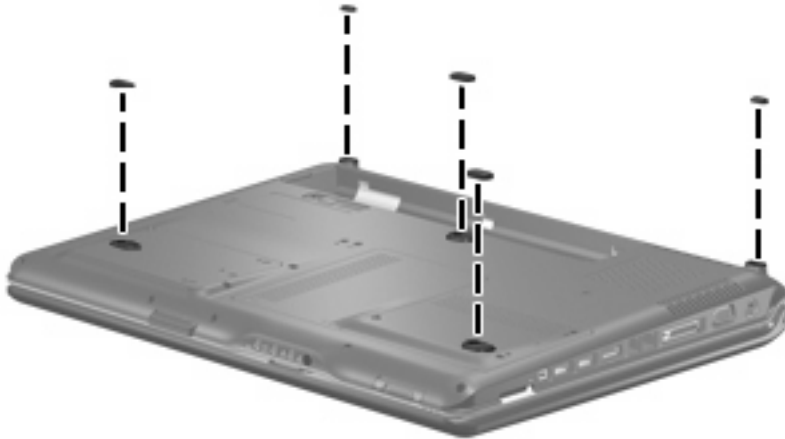

Memory module

Description	Spare part number
2048-MB (667-MHz, PC2-5300, 1-DIMM)	448003-001
1024-MB (667-MHz, PC2-5300, 1-DIMM)	446495-001
512-MB (667-MHz, PC2-5300, 1-DIMM)	446494-001

Before removing the memory module, follow these steps:

1. Shut down the computer. If you are unsure whether the computer is off or in Hibernation, turn the computer on, and then shut it down through the operating system.
2. Disconnect all external devices connected to the computer.
3. Disconnect the power from the computer by first unplugging the power cord from the AC outlet and then unplugging the AC adapter from the computer.
4. Remove the battery (see [Battery on page 40](#)).

Remove the memory module:

1. Position the computer with the front toward you.
2. Loosen the two Phillips PM2.5×5.0 captive screws **(1)** that secure the memory/WLAN module compartment cover to the computer.

3. Lift the front of the cover **(2)**, swing it toward the back of the computer, then remove the cover. The memory/WLAN module compartment cover is included in the Plastics Kit, spare part number 448009-001.

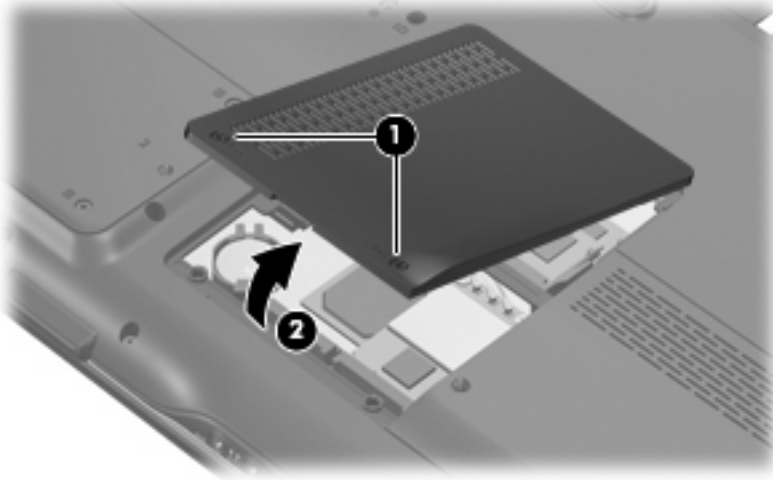

4. Spread the retaining tabs **(1)** on each side of the memory module slot to release the memory module. (The edge of the module opposite the slot rises away from the computer.)
5. Remove the module **(2)** by pulling it away from the slot at an angle.



NOTE: Memory modules are designed with a notch **(3)** to prevent incorrect installation into the memory module slot.

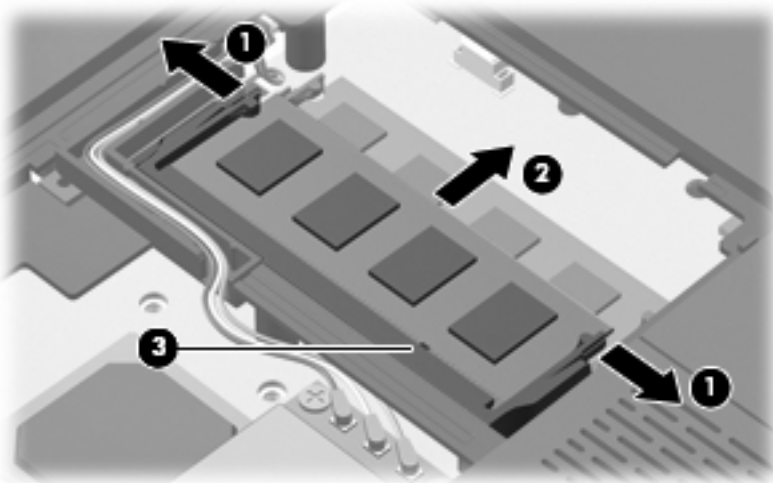

Reverse this procedure to install a memory module.

RTC battery

 **NOTE:** Removing the RTC battery and leaving it uninstalled for 5 or more minutes causes all passwords and CMOS settings to be cleared.

Description	Spare part number
RTC battery (includes 2-sided tape)	448013-001

Before removing the RTC battery, follow these steps:

1. Shut down the computer. If you are unsure whether the computer is off or in Hibernation, turn the computer on, and then shut it down through the operating system.
2. Disconnect all external devices connected to the computer.
3. Disconnect the power from the computer by first unplugging the power cord from the AC outlet and then unplugging the AC adapter from the computer.
4. Remove the battery (see [Battery on page 40](#)).
5. Remove the memory/WLAN module compartment cover (see [Memory module on page 47](#)).

Remove the RTC battery:

- Remove the RTC battery from the socket on the system board.

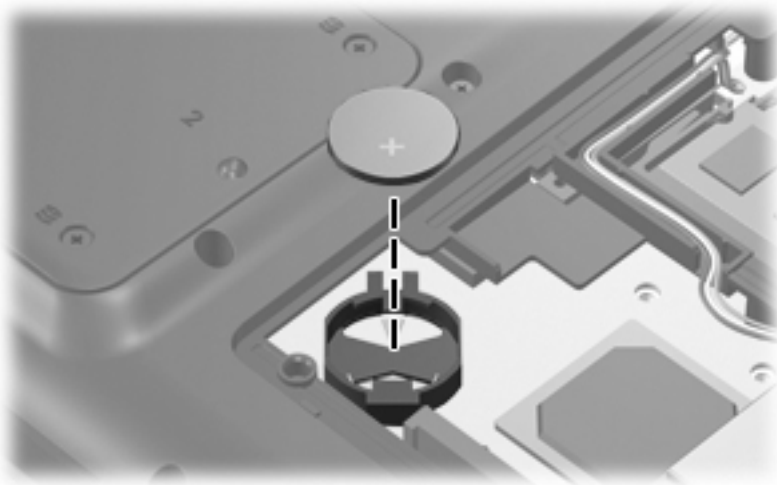

 **NOTE:** The RTC battery is secured to the computer by 2-sided tape. All replacement RTC battery spare part kits include 2-sided tape.

Reverse this procedure to install the RTC battery. Be sure the RTC battery is installed with the “+” sign facing up.

WLAN module

Description	Spare part number
Intel 802.11a/b/g/n WLAN modules	
For use in Antigua & Barbuda, Argentina, Aruba, the Bahamas, Barbados, Bermuda, Brunei, Canada, the Cayman Islands, Chile, Colombia, Costa Rica, the Dominican Republic, Ecuador, El Salvador, Guam, Guatemala, Haiti, Honduras, Hong Kong, India, Indonesia, Malaysia, Mexico, Panama, Paraguay, Peru, Saudi Arabia, Taiwan, Uruguay, the United States, Venezuela, and Vietnam	441086-001
For use in Austria, Azerbaijan, Bahrain, Belgium, Brazil, Bulgaria, Croatia, Cyprus, the Czech Republic, Denmark, Egypt, Estonia, Finland, France, Georgia, Germany, Greece, Hungary, Iceland, Ireland, Israel, Italy, Latvia, Lebanon, Liechtenstein, Lithuania, Luxembourg, Malta, Monaco, the Netherlands, Norway, Oman, the Philippines, Poland, Portugal, Qatar, Romania, Russia, Serbia and Montenegro, Singapore, Slovakia, Slovenia, South Africa, Spain, Sri Lanka, Sweden, Switzerland, Turkey, Ukraine, the United Kingdom, and Uzbekistan	441087-002
For use in Australia, New Zealand, Pakistan, the People's Republic of China, and South Korea	441088-003
For use in Japan	441089-291
Broadcom 802.11a/b/g WLAN modules	
For use in Antigua & Barbuda, Argentina, Australia, the Bahamas, Barbados, Brunei, Canada, Chile, the Dominican Republic, Guam, Guatemala, Hong Kong, India, Indonesia, Malaysia, Mexico, New Zealand, Panama, Paraguay, Saudi Arabia, Taiwan, the United States, and Vietnam	407674-001
For use in Aruba, Austria, Azerbaijan, Bahrain, Belgium, Bermuda, Brazil, Bulgaria, the Cayman Islands, Colombia, Croatia, Cyprus, the Czech Republic, Denmark, Egypt, El Salvador, Estonia, Finland, France, Georgia, Germany, Greece, Hungary, Iceland, Ireland, Italy, Jordan, Latvia, Lebanon, Liechtenstein, Lithuania, Luxembourg, Malta, Monaco, the Netherlands, Norway, Oman, the Philippines, Poland, Portugal, Romania, Russia, Serbia and Montenegro, Singapore, Slovakia, Slovenia, South Africa, Spain, Sri Lanka, Sweden, Switzerland, Turkey, the United Kingdom, and Uzbekistan	407674-002
For use in Ecuador, Haiti, Honduras, Pakistan, Peru, the People's Republic of China, Qatar, South Korea, Uruguay, and Venezuela	407674-003
For use in Japan	407674-291
Broadcom 802.11b/g WLAN module for use in Thailand	407674-004

Before removing the WLAN module, follow these steps:

1. Shut down the computer. If you are unsure whether the computer is off or in Hibernation, turn the computer on, and then shut it down through the operating system.
2. Disconnect all external devices connected to the computer.
3. Disconnect the power from the computer by first unplugging the power cord from the AC outlet and then unplugging the AC adapter from the computer.
4. Remove the battery (see [Battery on page 40](#)).
5. Remove the memory/WLAN module compartment cover (see [Memory module on page 47](#)).

Remove the WLAN module:

1. Disconnect the WLAN antenna cables **(1)** from the WLAN module.

 **NOTE:** The black WLAN antenna cable is connected to the WLAN module “Main” terminal. The white WLAN antenna cable is connected to the WLAN module “Aux” terminal.

NOTE: Computer models equipped with an 802.11ab/g/n WLAN module will have an additional wireless antenna cable **(2)**, yellow in color.

2. Remove the two Phillips PM2.0×11.0 screws **(3)** that secure the WLAN module to the computer. (The edge of the module opposite the slot rises away from the computer.)
3. Remove the WLAN module **(4)** by pulling it away from the slot at an angle.

 **NOTE:** WLAN modules are designed with a notch **(5)** to prevent incorrect installation into the WLAN module slot.

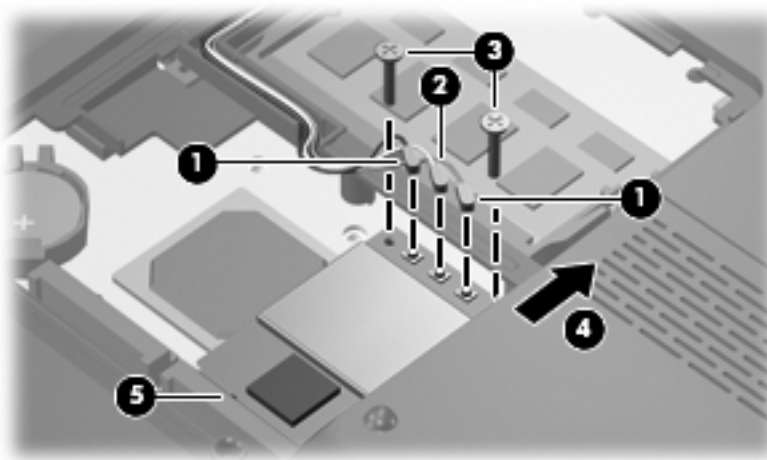

Reverse this procedure to install a WLAN module.

Optical drive

 **NOTE:** All optical drive spare part kits include an optical drive bezel and bracket.

Description	Spare part number
DVD±RW and CD-RW Super Multi Double-Layer Combo Drive with LightScribe	448005-001
DVD±RW and CD-RW Super Multi Double-Layer Combo Drive	448004-001

Before removing the optical drive, follow these steps:

1. Shut down the computer. If you are unsure whether the computer is off or in Hibernation, turn the computer on, and then shut it down through the operating system.
2. Disconnect all external devices connected to the computer.
3. Disconnect the power from the computer by first unplugging the power cord from the AC outlet and then unplugging the AC adapter from the computer.
4. Remove the battery (see [Battery on page 40](#)).

Remove the optical drive:

1. Position the computer with right side toward you.
2. Remove the Phillips PM2.5×8.0 screw **(1)** that secures the optical drive to the computer.
3. Insert a thin tool, such as a paper clip **(2)**, into the disc tray release access hole. (The optical drive disc tray is partially ejected from the optical drive.)
4. Use the disc tray frame to slide the optical drive **(3)** out of the computer.
5. Remove the optical drive.

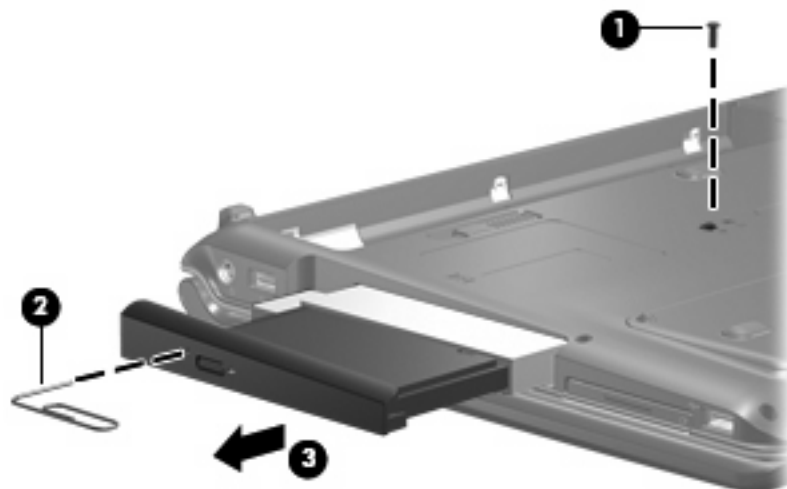

6. If it is necessary to replace the optical drive bracket, position the optical drive with the optical drive bracket toward you.
7. Remove the two Phillips PM2.0×3.0 screws **(1)** that secure the optical drive bracket to the optical drive.

8. Remove the optical drive bracket **(2)**.

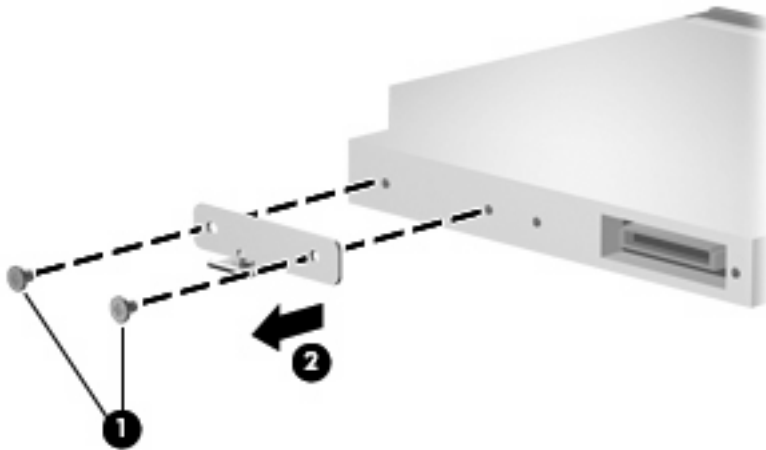

Reverse the above procedure to reassemble and install the optical drive.

Switch cover

Description	Spare part number
Switch cover (includes LED board and LED board cable)	448014-001

Before removing the switch cover, follow these steps:

1. Shut down the computer. If you are unsure whether the computer is off or in Hibernation, turn the computer on, and then shut it down through the operating system.
2. Disconnect all external devices connected to the computer.
3. Disconnect the power from the computer by first unplugging the power cord from the AC outlet and then unplugging the AC adapter from the computer.
4. Remove the battery (see [Battery on page 40](#)).

Remove the switch cover:

1. Position the computer with the front toward you.
2. Remove the six Phillips PM2.5×5.0 screws that secure the switch cover to the computer.

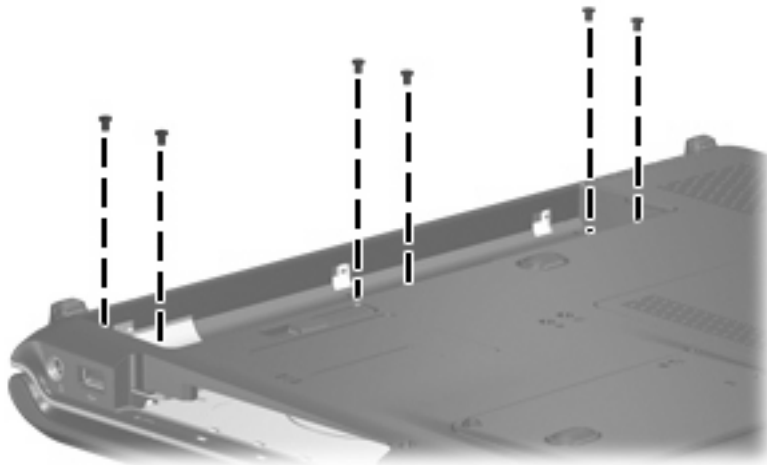

3. Turn the computer display-side up, with the front toward you.
4. Open the computer as far as possible.

5. Lift the rear edge of the switch cover and swing it forward until it rests on the keyboard.



6. Release the zero insertion force (ZIF) connector **(1)** to which the LED board cable is connected and disconnect the cable **(2)** from the LED board.

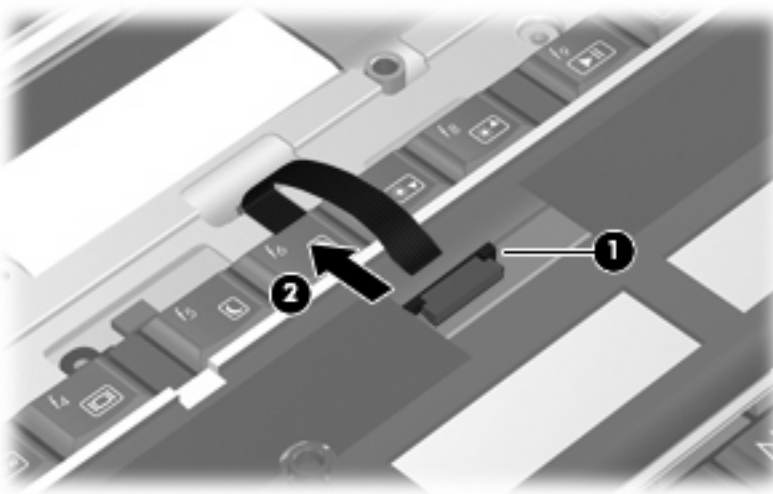

7. Remove the switch cover.

Reverse this procedure to install the switch cover.

Keyboard

Description			
For use in:	Spare part number	For use in:	Spare part number
Belgium	441541-A41	Latin America	441541-161
Denmark, Finland, Norway, and Sweden	441541-DH1	Portugal	441541-131
France	441541-051	Russia	441541-251
French Canada	441541-121	Saudi Arabia	441541-171
Germany	441541-041	Spain	441541-071
Greece	441541-151	Switzerland	441541-111
International	441541-B31	Thailand	441541-281
Israel	441541-BB1	Turkey	441541-141
Italy	441541-061	The United Kingdom	441541-031
Japan	441541-291	The United States	441541-001
Korea	441541-AD1		

Before removing the keyboard, follow these steps:

1. Shut down the computer. If you are unsure whether the computer is off or in Hibernation, turn the computer on, and then shut it down through the operating system.
2. Disconnect all external devices connected to the computer.
3. Disconnect the power from the computer by first unplugging the power cord from the AC outlet and then unplugging the AC adapter from the computer.
4. Remove the battery (see [Battery on page 40](#)).
5. Remove the switch cover (see [Switch cover on page 54](#)).

Remove the keyboard:

1. Turn the computer upside down, with the front toward you.

2. Remove the Phillips PM2.5×8.0 screw that secures the keyboard to the computer.

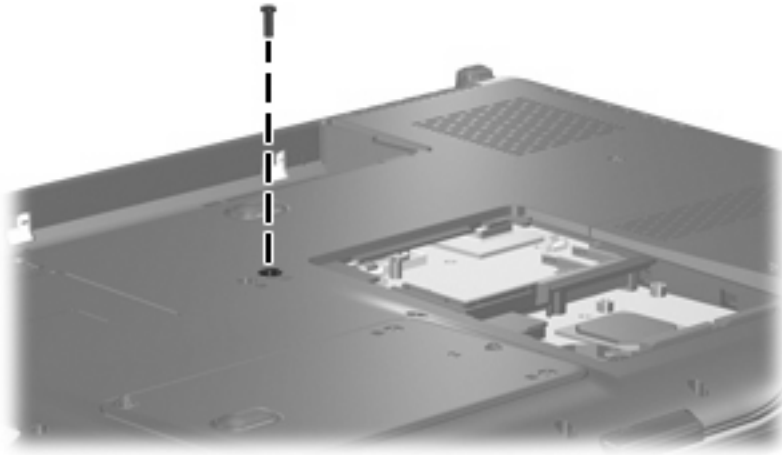

3. Turn the computer display-side up, with the front toward you.
4. Open the computer as far as possible.
5. Remove the three silver Phillips PM2.5×5.0 screws that secure the keyboard to the computer.

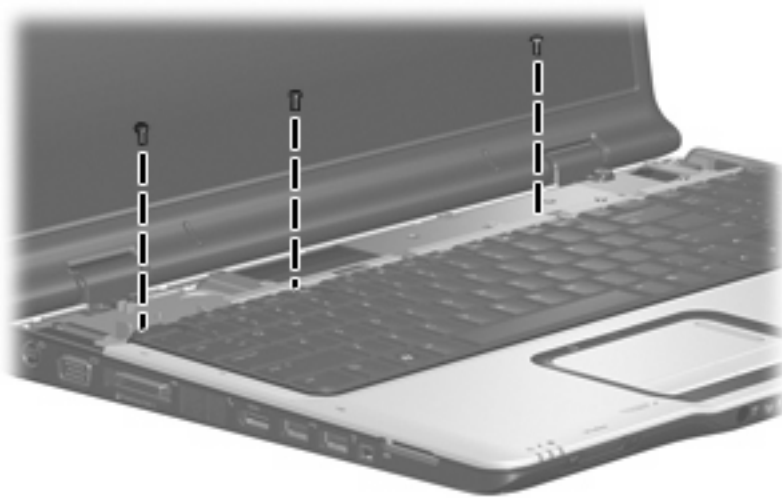

6. Lift the rear edge of the keyboard **(1)** until it rests at an angle.
7. Slide the keyboard **(2)** back to disengage the tabs on the front edge of the keyboard from the top cover.

8. Swing the keyboard **(3)** up and forward until it rests on the palm rest.

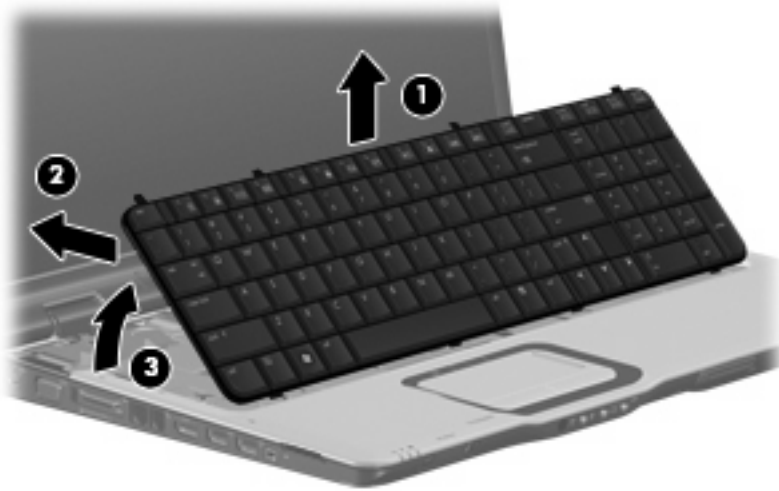

9. Release the ZIF connector **(1)** to which the keyboard cable is attached and disconnect the keyboard cable **(2)**.

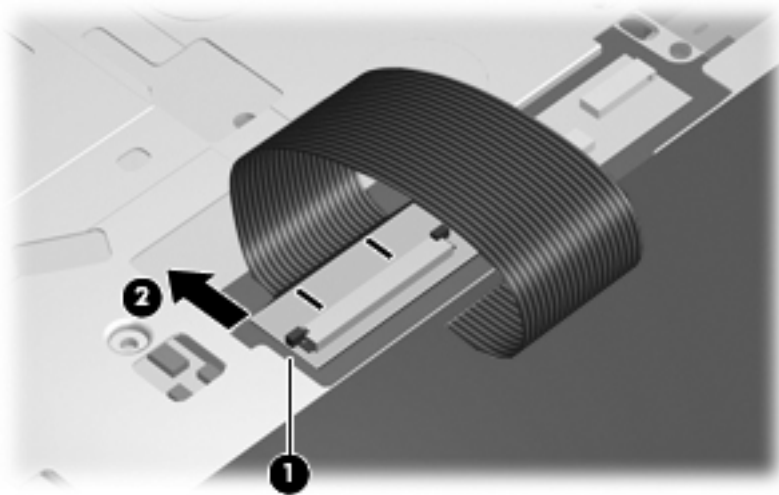

10. Remove the keyboard.

Reverse this procedure to install the keyboard.

Speaker assembly

Description	Spare part number
Speaker assembly	432994-001

Before removing the speaker assembly, follow these steps:

1. Shut down the computer. If you are unsure whether the computer is off or in Hibernation, turn the computer on, and then shut it down through the operating system.
2. Disconnect all external devices connected to the computer.
3. Disconnect the power from the computer by first unplugging the power cord from the AC outlet and then unplugging the AC adapter from the computer.
4. Remove the battery (see [Battery on page 40](#)).
5. Remove the switch cover (see [Switch cover on page 54](#)).
6. Remove the keyboard (see [Keyboard on page 56](#)).

Remove the speaker assembly:

1. Disconnect the speaker assembly cable **(1)** from the power button board.
2. Remove the wireless antenna cables and microphone cable from the clips **(2)** in the speaker assembly.

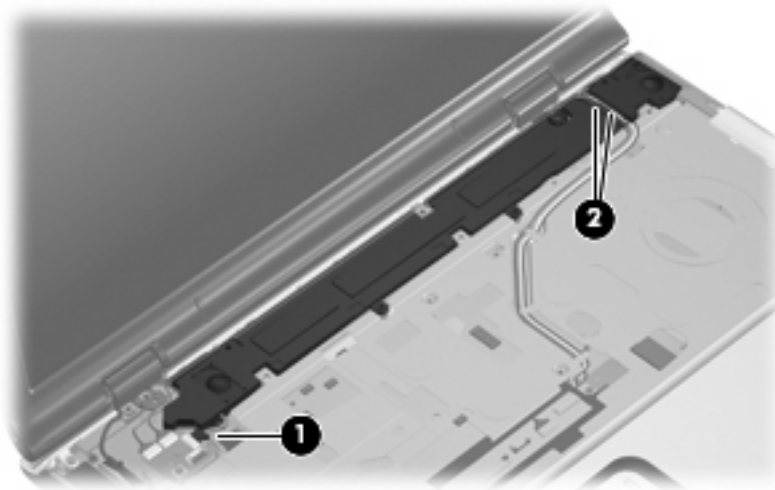

3. Remove the two black Phillips PM2.5×5.0 screws **(1)** that secure the speaker assembly to the computer.

4. Remove the speaker assembly **(2)**.

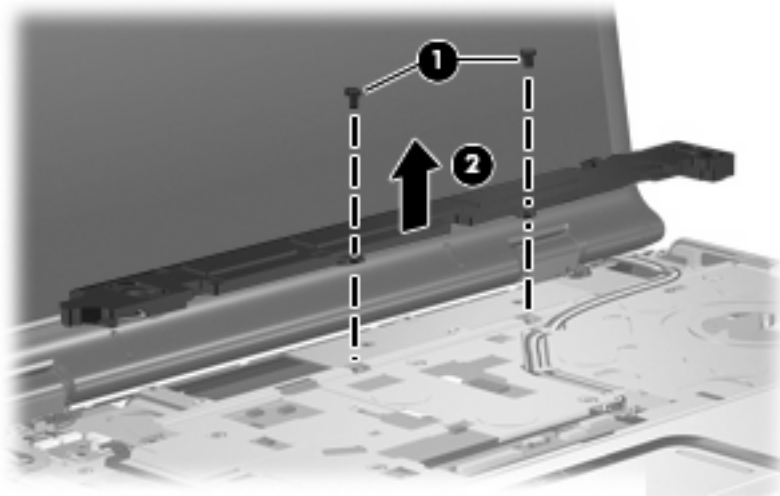

Reverse this procedure to install the speaker assembly.

Power button board

Description	Spare part number
Power button board (includes power button board cable)	432987-001

Before removing the power button board, follow these steps:

1. Shut down the computer. If you are unsure whether the computer is off or in Hibernation, turn the computer on, and then shut it down through the operating system.
2. Disconnect all external devices connected to the computer.
3. Disconnect the power from the computer by first unplugging the power cord from the AC outlet and then unplugging the AC adapter from the computer.
4. Remove the battery (see [Battery on page 40](#)).
5. Remove the switch cover (see [Switch cover on page 54](#)).
6. Remove the keyboard (see [Keyboard on page 56](#)).

Remove the power button board:

1. Disconnect the following cables from the power button board:
 - (1) Power button board cable
 - (2) Speaker assembly cable
 - (3) Display switch module cable
 - (4) Microphone cable

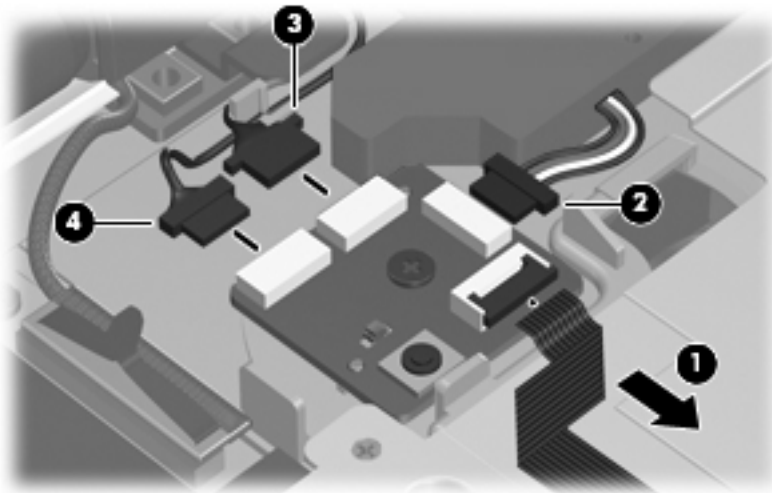

2. Remove the silver Phillips PM2.5×5.0 screw (1) that secures the power button board to the computer.
3. Remove the power button board (2).

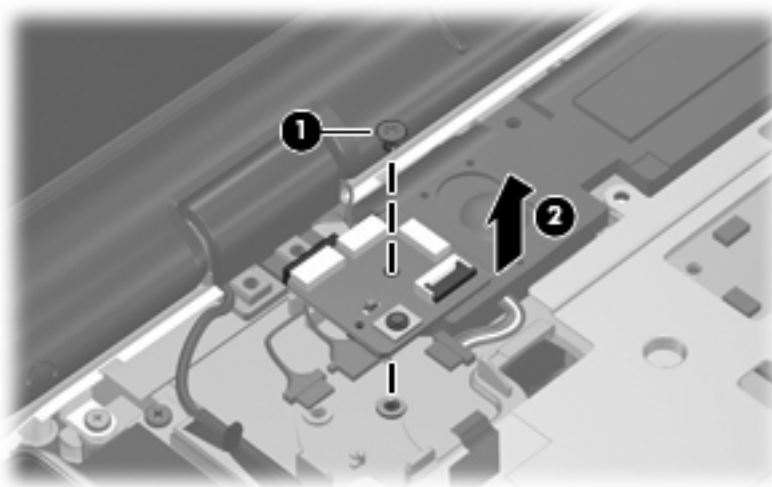

Reverse this procedure to install the power button board.

Display assembly

Description	Spare part number
17.0-inch, SXGA+, TFT, single lamp, BrightView display assembly for use only with computer models equipped with a camera (includes wireless antenna transceivers and cables)	447990-001
17.0-inch, WXGA+, TFT, single lamp, BrightView display assembly for use only with computer models equipped with a camera (includes wireless antenna transceivers and cables)	447989-001
17.0-inch, SXGA+, TFT, single lamp, BrightView display assembly for use only with not equipped with a camera (includes wireless antenna transceivers and cables)	447993-001
17.0-inch, WXGA+, TFT, single lamp, BrightView display assembly for use only with not equipped with a camera (includes wireless antenna transceivers and cables)	447992-001

Before removing the display assembly, follow these steps:

1. Shut down the computer. If you are unsure whether the computer is off or in Hibernation, turn the computer on, and then shut it down through the operating system.
2. Disconnect all external devices connected to the computer.
3. Disconnect the power from the computer by first unplugging the power cord from the AC outlet and then unplugging the AC adapter from the computer.
4. Remove the battery (see [Battery on page 40](#)).
5. Remove the memory/WLAN module compartment cover (see [Memory module on page 47](#)).
6. Disconnect the wireless antenna cables from the WLAN module (see [WLAN module on page 50](#)).
7. Remove the following components:
 - a. Switch cover (see [Switch cover on page 54](#))
 - b. Keyboard (see [Keyboard on page 56](#))
 - c. Speaker assembly (see [Speaker assembly on page 59](#))

Remove the display assembly:

1. Close the computer and turn it upside down, with the front toward you.

2. Remove the two Phillips PM2.5×8.0 screws that secure the display assembly to the computer.

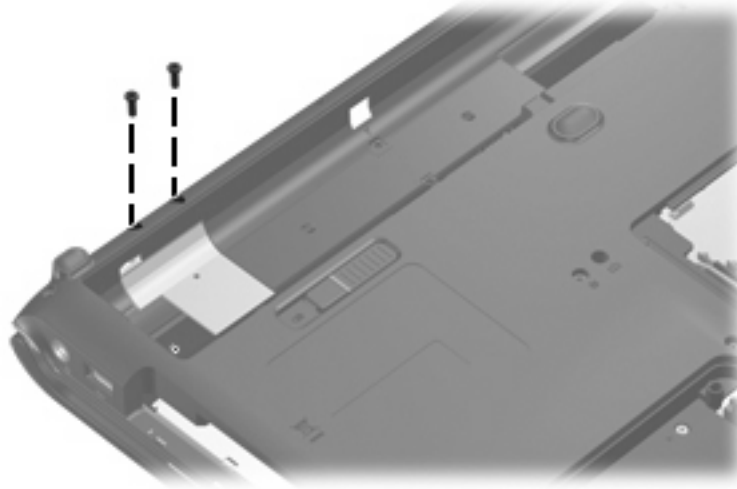

3. Turn the computer display-side up, with the front toward you.
4. Open the computer to an upright position.
5. Disconnect the following cables:
 - (1) Display panel cable
 - (2) Microphone cable
 - (3) Camera cable
6. Remove the wireless antenna cables (4) from the routing channels in the top cover.

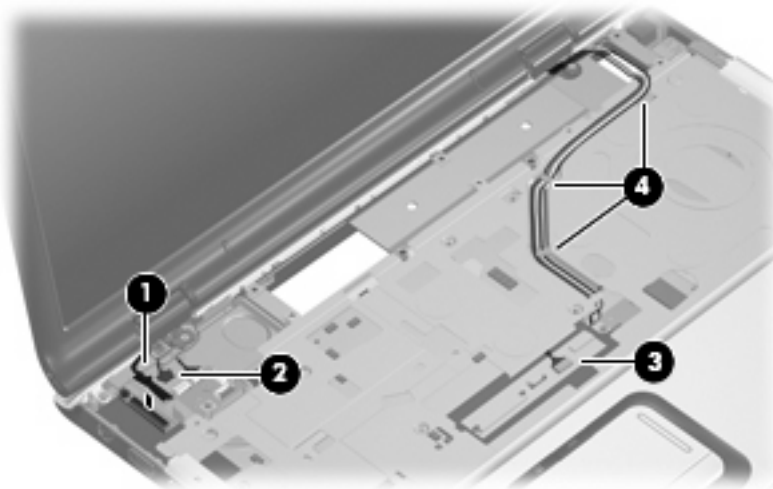

△ **CAUTION:** Support the display assembly when removing the following screws. Failure to support the display assembly can result in damage to the display assembly and other computer components.

7. Remove the two Phillips PM2.5×8.0 screws (1) and the two silver Phillips PM2.5×5.0 screws (2) that secure the display assembly to the computer.

8. Remove the display assembly **(3)**.

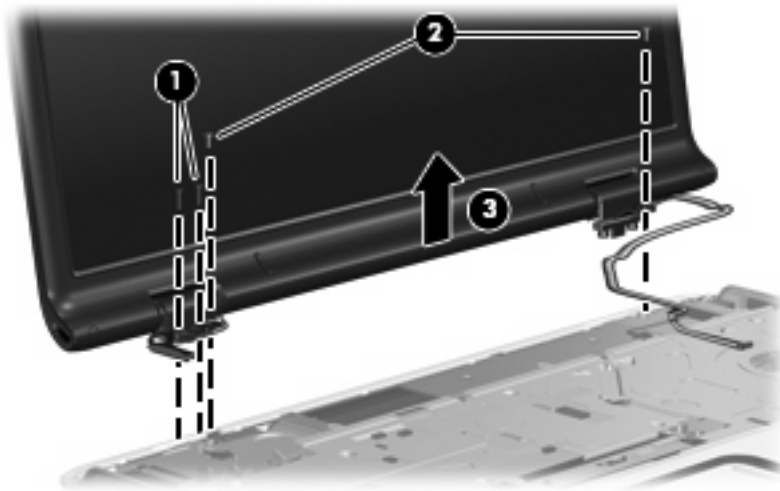

9. If it is necessary to replace the display bezel or any of the display assembly internal components, remove the following screw covers and screws:

(1) Three rubber screw covers on the display bezel top edge. The display rubber screw covers are included in the Rubber Kit, spare part number 448017-001.

(2) Two rubber screw covers on the display bezel bottom edge.

(3) Five Phillips PM2.5×8.0 screws.

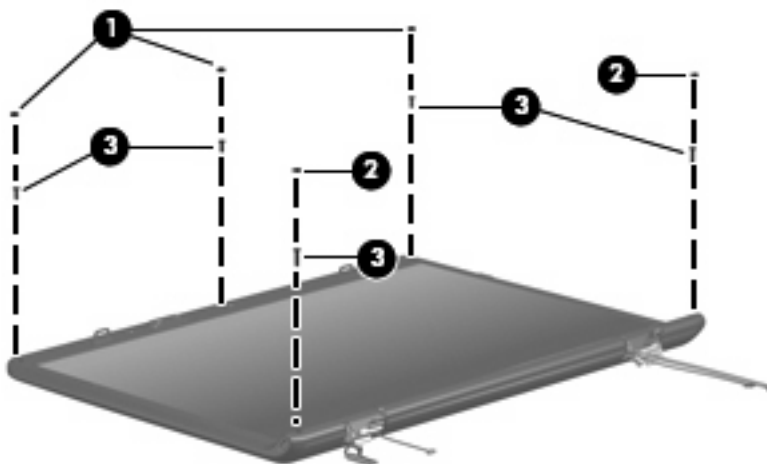

10. Flex the inside edges of the left and right sides **(1)** and the top and bottom sides **(2)** of the display bezel until the bezel disengages from the display enclosure.
11. Remove the display bezel **(3)**. Display bezels are available using the following spare part numbers:
- 447997-001 (for use only with computer models equipped with a camera)
 - 447996-001 (for use only with computer models not equipped with a camera)

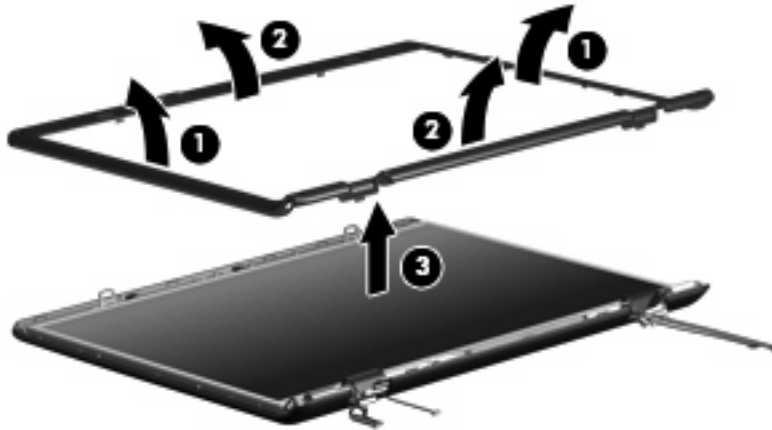

 **NOTE:** See [Camera module on page 41](#) for camera module replacement instructions. See [Display inverter on page 43](#) for display inverter replacement instructions.

12. If it is necessary to replace the display panel, remove the four Phillips PM2.5×8.0 screws **(1)** and the two Phillips PM2.5×6.0 screws **(2)** that secure the display panel to the display enclosure.
13. Remove the display panel **(3)**. Display panels are available using the following spare part numbers:
 - 447987-001 (17.0-inch, SXGA+, TFT, single lamp, BrightView display assembly)
 - 447986-001 (17.0-inch, WXGA+, TFT, single lamp, BrightView display assembly)

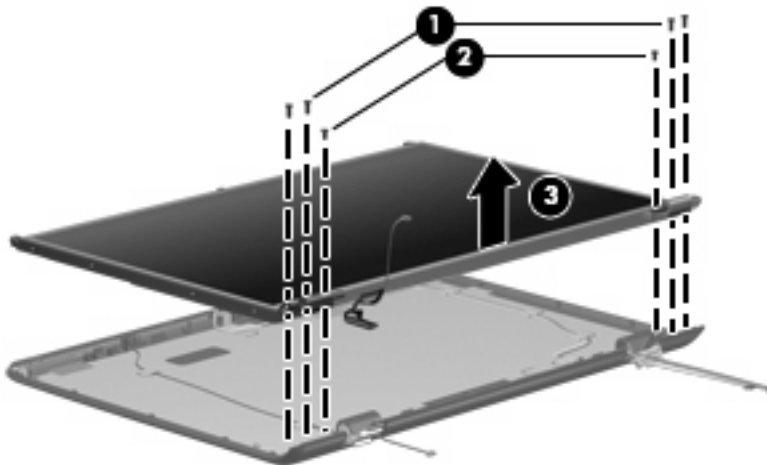

14. If it is necessary to replace the display hinges, remove the two Phillips PM2.0×3.0 screws **(1)** that secure each display hinge to the display panel.
15. Remove the display hinges **(2)**.

16. Remove the left and right hinge covers (**3**) by sliding them off of the display hinges. The display hinges are available using spare part number 432963-001. The display hinge covers are available using spare part number 432965-001.

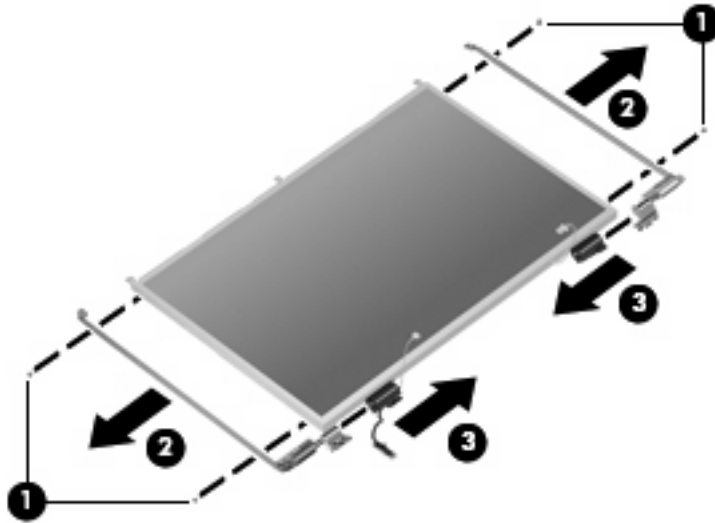

17. If it is necessary to replace the wireless antenna transceivers and cables, remove the two Phillips PM2.0x4.0 screws (**1**) that secure each transceiver to the display enclosure.
18. Remove the wireless antenna cables from the clips (**2**) built into the display enclosure.
19. Detach the wireless antenna transceivers (**3**) from the display enclosure.
20. Remove the wireless antenna cables (**4**). The wireless antenna transceivers and cables are available using the following spare part numbers:
- 448313-001 (for use with computer models equipped with an 802.11a/b/g/n WLAN module)
 - 448312-001 (for use with computer models equipped with an 802.11a/b/g or 802.11b/g WLAN module)

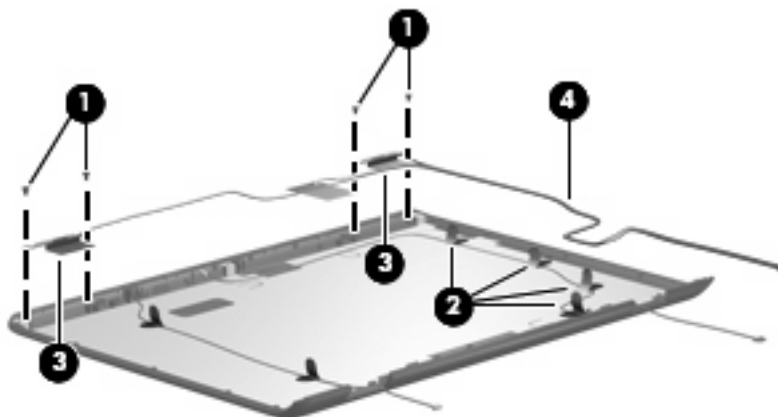

21. If it is necessary to replace the microphones and cables, release the retention tabs (**1**) built into the display enclosure that secure the microphone cables to the display enclosure.
22. Remove the microphone receivers (**2**) from the clips in the display enclosure.

23. Remove the microphone cables **(3)** from the display enclosure. The microphones and cables are available using spare part number 432961-001.

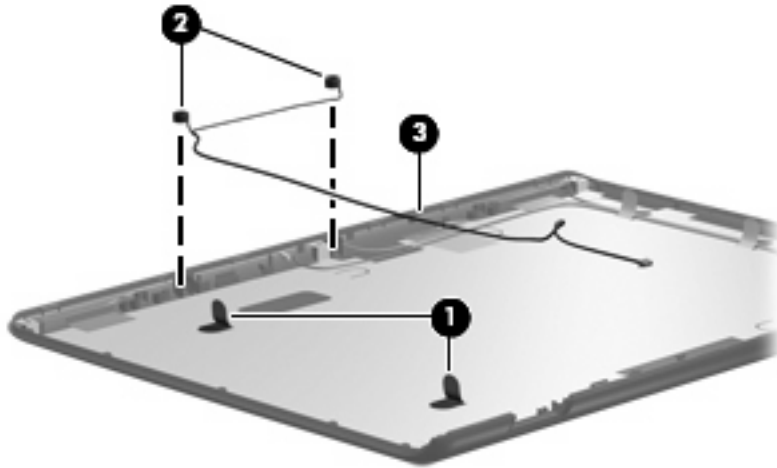

24. If it is necessary to replace the camera cable, release the retention tabs **(1)** built into the display enclosure that secure the camera cable to the display enclosure.
25. Remove the camera cable **(2)** from the display enclosure. The camera cable is available in the Display Cable Kit, spare part number 432962-001.

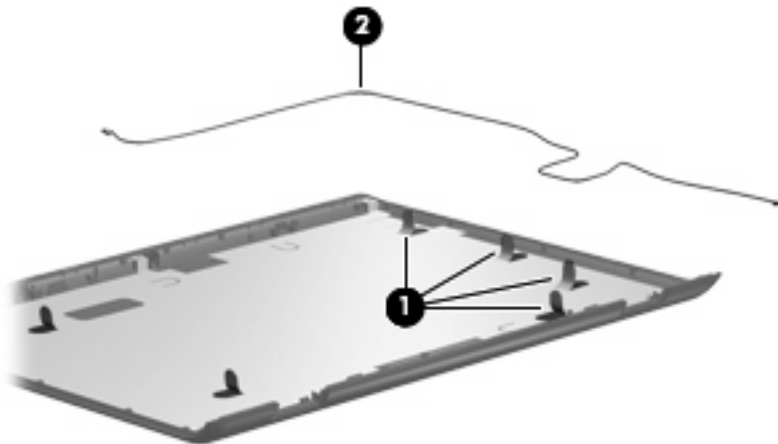

Reverse this procedure to reassemble and install the display assembly.

Top cover

Description	Spare part number
Top cover for use only with computer models equipped with a fingerprint reader (includes TouchPad, TouchPad cable, fingerprint reader board, and fingerprint reader board cable)	448011-001
Top cover for use only with computer models not equipped with a fingerprint reader (includes TouchPad and TouchPad cable)	448010-001
Fingerprint reader board (includes fingerprint reader board cable)	448012-001

Before removing the top cover, follow these steps:

1. Shut down the computer. If you are unsure whether the computer is off or in Hibernation, turn the computer on, and then shut it down through the operating system.
2. Disconnect all external devices connected to the computer.
3. Disconnect the power from the computer by first unplugging the power cord from the AC outlet and then unplugging the AC adapter from the computer.
4. Remove the battery (see [Battery on page 40](#)).
5. Remove the following components:
 - a. Hard drive (see [Hard drive on page 45](#))
 - b. Optical drive (see [Optical drive on page 52](#))
 - c. Switch cover (see [Switch cover on page 54](#))
 - d. Keyboard (see [Keyboard on page 56](#))
 - e. Speaker assembly (see [Speaker assembly on page 59](#))
 - f. Display assembly (see [Display assembly on page 62](#))

Remove the top cover:

1. Turn the computer upside down, with the front toward you.

2. Remove the eight Phillips PM2.5×8.0 screws that secure the top cover to the computer.

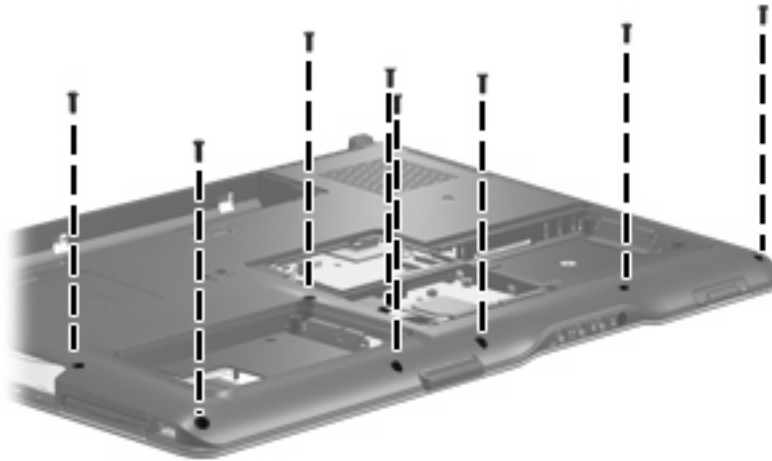

3. Remove the four silver Phillips PM2.5×5.0 screws that secure the top cover to the computer.

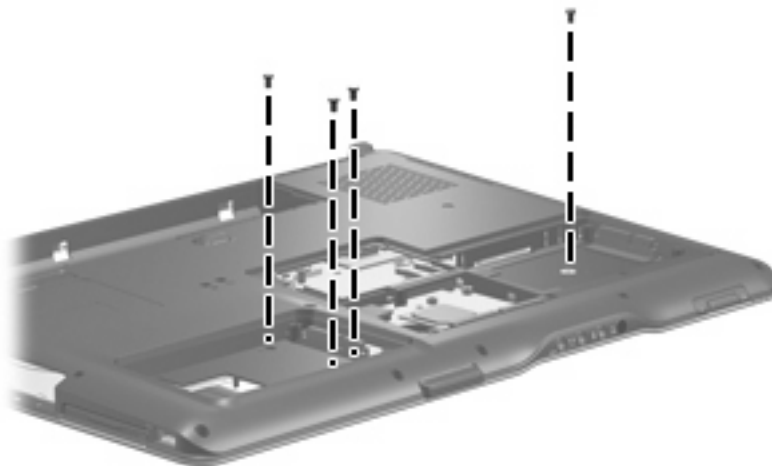

4. Turn the computer right-side up, with the front toward you.

5. Disconnect the power button board cable **(1)** and the LED board cable **(2)** from the low insertion force (LIF) connectors on the system board.

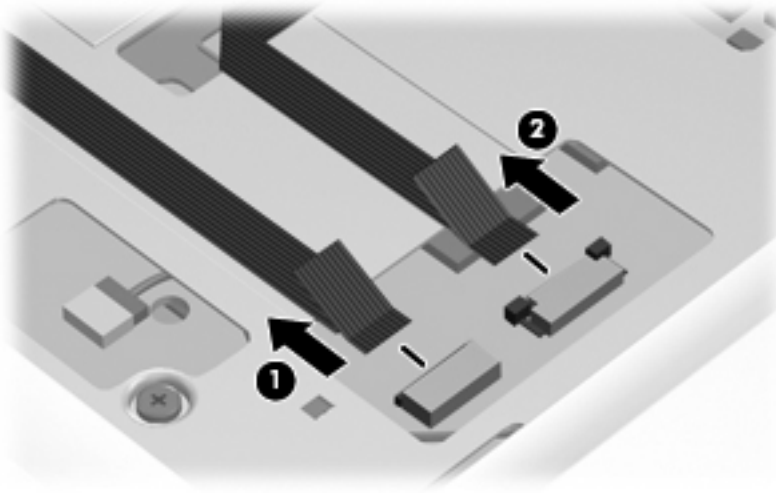

6. Release the ZIF connector **(1)** to which the TouchPad cable **(2)** is attached and disconnect the cable from the system board.

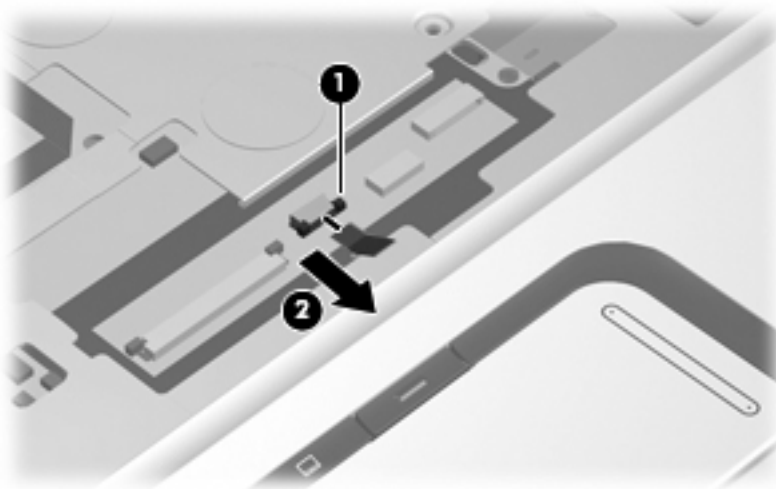

7. Remove the five Phillips PM2.5×8.0 screws **(1)** and the two silver Phillips PM2.5×5.0 screws **(2)** that secure the top cover to the base enclosure.

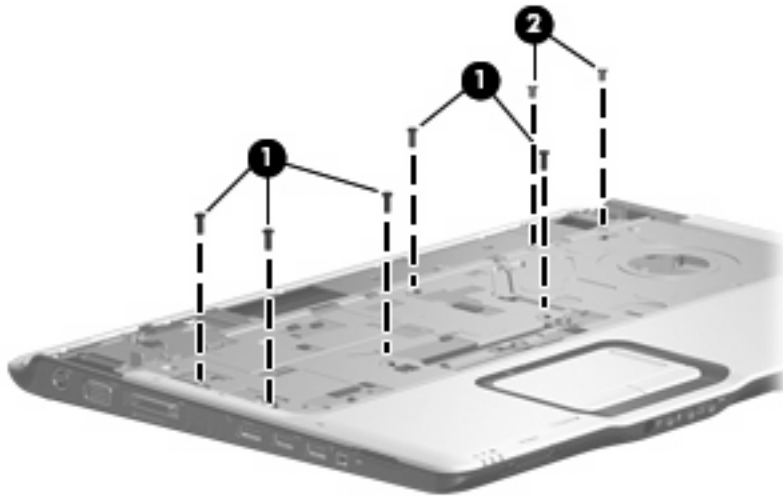

8. Lift the rear edge of the top cover until it disengages from the computer, then swing it up and forward until the top cover is resting upside down in front of the computer.

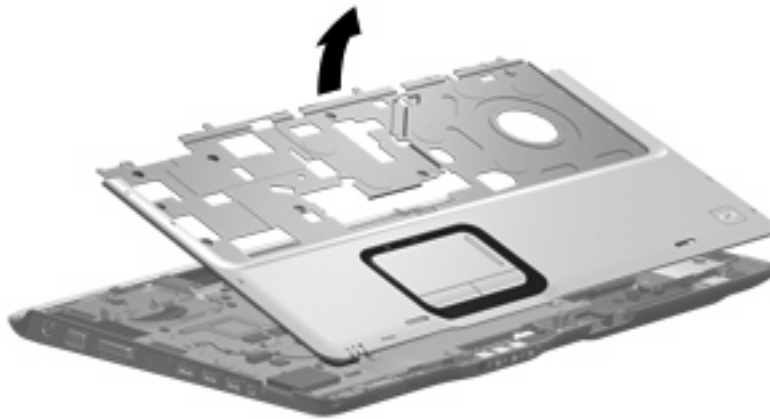

9. Release the ZIF connector to which the fingerprint reader board cable **(1)** is attached and disconnect the cable **(2)** from the system board.

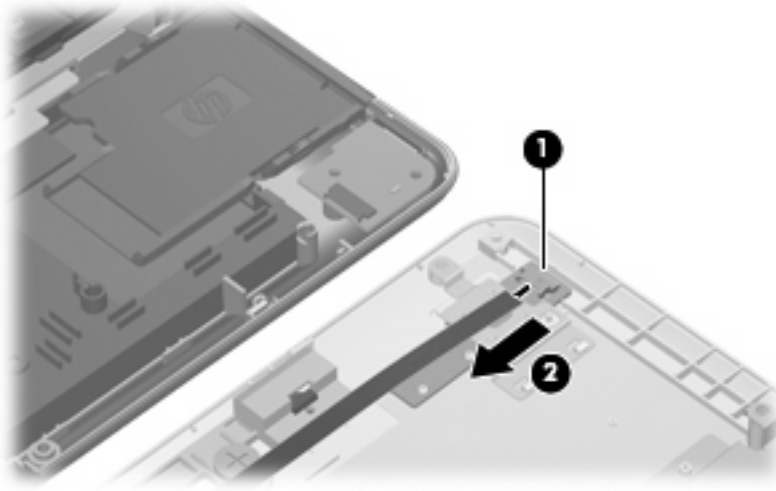

10. Remove the top cover.

Reverse this procedure to install the top cover.

Wireless switch board

Description	Spare part number
Wireless switch board (includes wireless switch board cable)	432991-001

Before removing the wireless switch board, follow these steps:

1. Shut down the computer. If you are unsure whether the computer is off or in Hibernation, turn the computer on, and then shut it down through the operating system.
2. Disconnect all external devices connected to the computer.
3. Disconnect the power from the computer by first unplugging the power cord from the AC outlet and then unplugging the AC adapter from the computer.
4. Remove the battery (see [Battery on page 40](#)).
5. Remove the following components:
 - a. Hard drive (see [Hard drive on page 45](#))
 - b. Optical drive (see [Optical drive on page 52](#))
 - c. Switch cover (see [Switch cover on page 54](#))
 - d. Keyboard (see [Keyboard on page 56](#))
 - e. Speaker assembly (see [Speaker assembly on page 59](#))
 - f. Display assembly (see [Display assembly on page 62](#))
 - g. Top cover (see [Top cover on page 68](#))

Remove the wireless switch board:

1. Release the ZIF connector to which the wireless switch board cable is connected and disconnect the wireless switch board cable **(1)** from the system board.
2. Remove the two silver Phillips PM2.5×5.0 screws **(2)** that secure the wireless switch board to the base enclosure.

3. Remove the wireless switch board **(3)**.

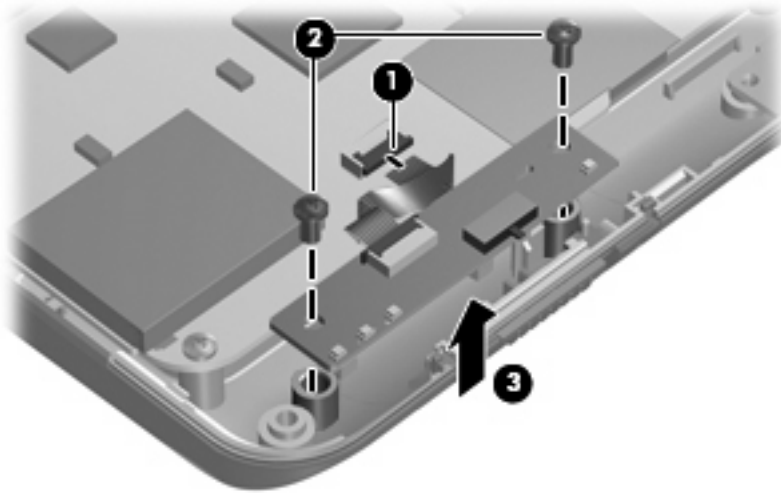

Reverse this procedure to install the wireless switch board.

Bluetooth module

Description	Spare part number
Bluetooth module (includes Bluetooth module cable)	412766-002

Before removing the Bluetooth module, follow these steps:

1. Shut down the computer. If you are unsure whether the computer is off or in Hibernation, turn the computer on, and then shut it down through the operating system.
2. Disconnect all external devices connected to the computer.
3. Disconnect the power from the computer by first unplugging the power cord from the AC outlet and then unplugging the AC adapter from the computer.
4. Remove the battery (see [Battery on page 40](#)).
5. Remove the following components:
 - a. Hard drive (see [Hard drive on page 45](#))
 - b. Optical drive (see [Optical drive on page 52](#))
 - c. Switch cover (see [Switch cover on page 54](#))
 - d. Keyboard (see [Keyboard on page 56](#))
 - e. Speaker assembly (see [Speaker assembly on page 59](#))
 - f. Display assembly (see [Display assembly on page 62](#))
 - g. Top cover (see [Top cover on page 68](#))

Remove the Bluetooth module:

1. Disconnect the Bluetooth module cable **(1)** from the system board. The Bluetooth module cable is included with the Bluetooth module spare part kit and is also included in the Cable Kit, spare part number 448015-001.
2. Route the Bluetooth module cable **(2)** under the system board.
3. Remove the two silver Phillips PM2.0×3.0 screws **(3)** that secure the Bluetooth module to the base enclosure.

4. Remove the Bluetooth module **(4)**.

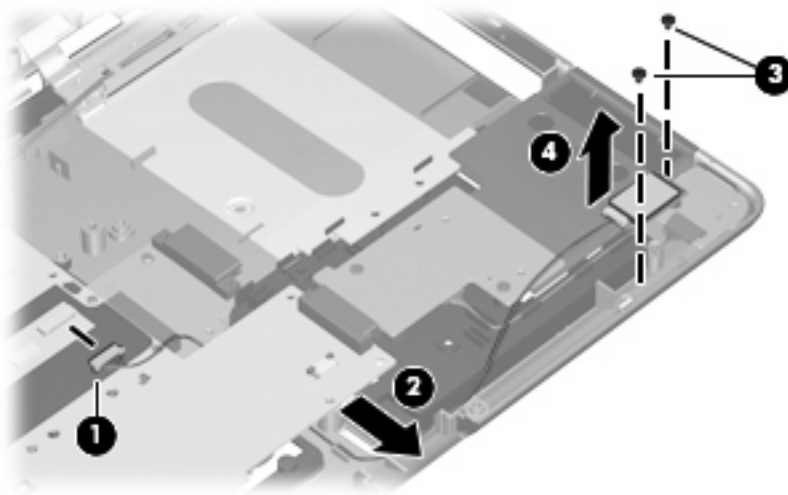

Reverse this procedure to install the Bluetooth module.

Front USB board

Description	Spare part number
Front USB board (includes front USB board cable)	449763-001

Before removing the front USB board, follow these steps:

1. Shut down the computer. If you are unsure whether the computer is off or in Hibernation, turn the computer on, and then shut it down through the operating system.
2. Disconnect all external devices connected to the computer.
3. Disconnect the power from the computer by first unplugging the power cord from the AC outlet and then unplugging the AC adapter from the computer.
4. Remove the battery (see [Battery on page 40](#)).
5. Remove the following components:
 - a. Hard drive (see [Hard drive on page 45](#))
 - b. Optical drive (see [Optical drive on page 52](#))
 - c. Switch cover (see [Switch cover on page 54](#))
 - d. Keyboard (see [Keyboard on page 56](#))
 - e. Speaker assembly (see [Speaker assembly on page 59](#))
 - f. Display assembly (see [Display assembly on page 62](#))
 - g. Top cover (see [Top cover on page 68](#))

Remove the front USB board:

1. Disconnect the front USB board cable **(1)** from the ExpressCard assembly. The front USB board cable is included with the front USB board spare part kit and is also included in the Cable Kit, spare part number 448015-001.
2. Remove the silver Phillips PM2.5×5.0 screw **(2)** that secures the front USB board to the computer.

3. Remove the front USB board (3).

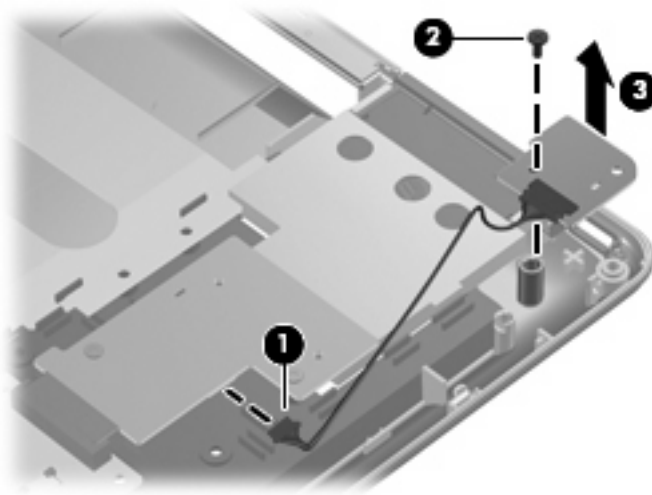

Reverse this procedure to install the front USB board.

ExpressCard assembly

Description	Spare part number
ExpressCard assembly	432988-001

Before removing the ExpressCard assembly, follow these steps:

1. Shut down the computer. If you are unsure whether the computer is off or in Hibernation, turn the computer on, and then shut it down through the operating system.
2. Disconnect all external devices connected to the computer.
3. Disconnect the power from the computer by first unplugging the power cord from the AC outlet and then unplugging the AC adapter from the computer.
4. Remove the battery (see [Battery on page 40](#)).
5. Remove the following components:
 - a. Hard drive (see [Hard drive on page 45](#))
 - b. Optical drive (see [Optical drive on page 52](#))
 - c. Switch cover (see [Switch cover on page 54](#))
 - d. Keyboard (see [Keyboard on page 56](#))
 - e. Speaker assembly (see [Speaker assembly on page 59](#))
 - f. Display assembly (see [Display assembly on page 62](#))
 - g. Top cover (see [Top cover on page 68](#))

Remove the ExpressCard assembly:

1. Press the ExpressCard slot bezel **(1)** to release the bezel from the ExpressCard slot.
2. Remove the ExpressCard slot bezel **(2)**. The ExpressCard slot bezel is included in the Plastics Kit, spare part number 448009-001.

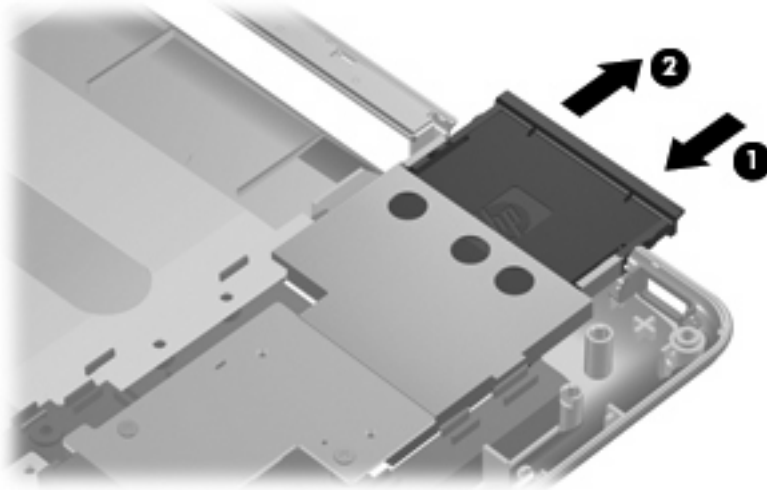

3. Remove the four silver Phillips PM2.5×5.0 screws **(1)** that secure the ExpressCard assembly to the system board.
4. Disconnect the ExpressCard assembly **(2)** from the system board by sliding it to the right.
5. Remove the ExpressCard assembly **(3)**.

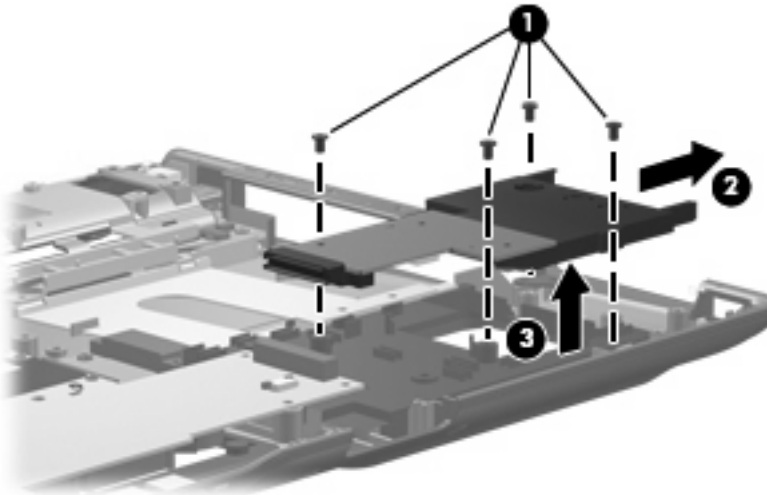

6. If it is necessary to replace the fingerprint reader board cable, release the ZIF connector **(1)** to which the cable is connected and disconnect the cable **(2)** from the system board. The fingerprint reader board cable is included in the Cable Kit, spare part number 448015-001.

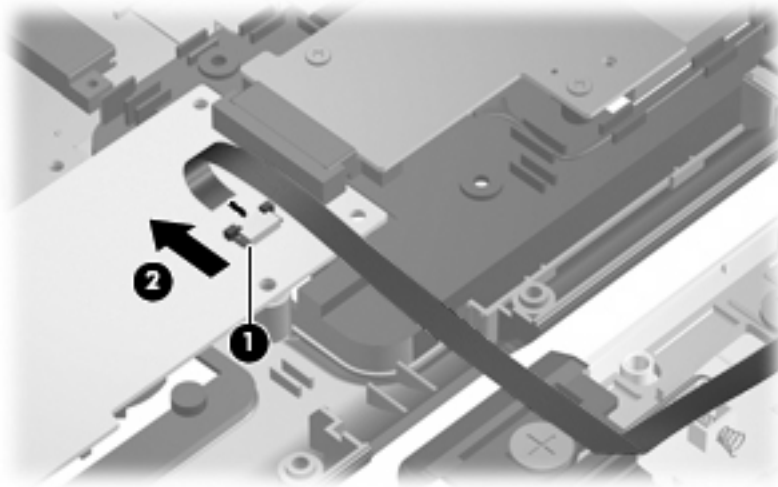

Reverse this procedure to install the ExpressCard assembly and the fingerprint reader board cable.

Top cover trim

Description	Spare part number
Top cover trim	432978-001

Before removing the top cover trim, follow these steps:

1. Shut down the computer. If you are unsure whether the computer is off or in Hibernation, turn the computer on, and then shut it down through the operating system.
2. Disconnect all external devices connected to the computer.
3. Disconnect the power from the computer by first unplugging the power cord from the AC outlet and then unplugging the AC adapter from the computer.
4. Remove the battery (see [Battery on page 40](#)).
5. Remove the following components:
 - a. Hard drive (see [Hard drive on page 45](#))
 - b. Optical drive (see [Optical drive on page 52](#))
 - c. Switch cover (see [Switch cover on page 54](#))
 - d. Keyboard (see [Keyboard on page 56](#))
 - e. Speaker assembly (see [Speaker assembly on page 59](#))
 - f. Display assembly (see [Display assembly on page 62](#))
 - g. Top cover (see [Top cover on page 68](#))

Remove the top cover trim:

1. Turn the computer upside down with the front toward you.
2. Remove the four Phillips PM2.5×8.0 screws that secure the top cover trim to the computer.

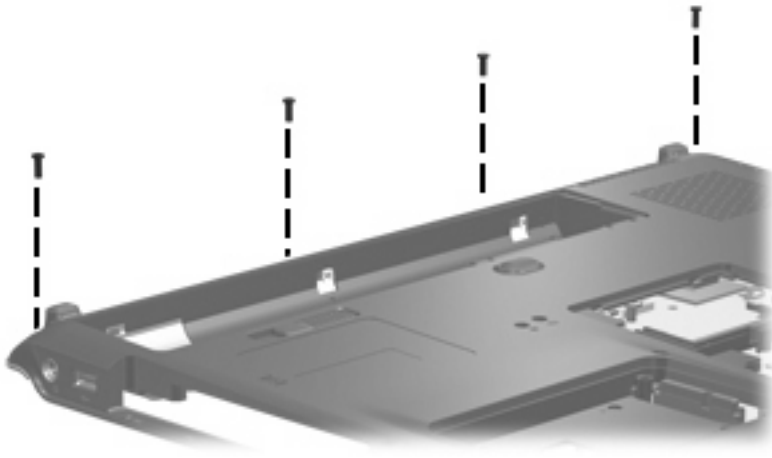

3. Turn the computer right-side up with the front toward you.
4. Remove the Phillips PM2.5×8.0 screw **(1)** that secures the top cover trim to the computer.
5. Remove the top cover trim **(2)**.

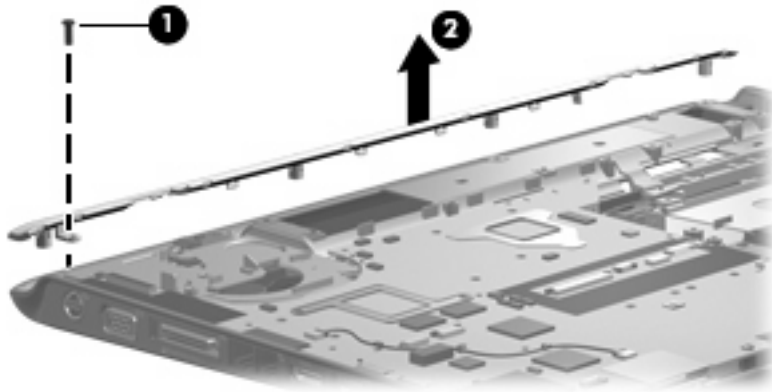

6. Remove the top cover trim.

Reverse this procedure to install the top cover trim.

Display switch module

Description	Spare part number
Display switch module (includes display switch module cable)	448435-001

Before removing the display switch module, follow these steps:

1. Shut down the computer. If you are unsure whether the computer is off or in Hibernation, turn the computer on, and then shut it down through the operating system.
2. Disconnect all external devices connected to the computer.
3. Disconnect the power from the computer by first unplugging the power cord from the AC outlet and then unplugging the AC adapter from the computer.
4. Remove the battery (see [Battery on page 40](#)).
5. Remove the following components:
 - a. Hard drive (see [Hard drive on page 45](#))
 - b. Optical drive (see [Optical drive on page 52](#))
 - c. Switch cover (see [Switch cover on page 54](#))
 - d. Keyboard (see [Keyboard on page 56](#))
 - e. Speaker assembly (see [Speaker assembly on page 59](#))
 - f. Display assembly (see [Display assembly on page 62](#))
 - g. Top cover (see [Top cover on page 68](#))
 - h. Top cover trim (see [Top cover trim on page 80](#))

Remove the display switch module:

1. Remove the Phillips PM2.5×5.0 screw **(1)** that secures the display switch module to the fan/heat sink assembly.

2. Remove the display switch module **(2)**.

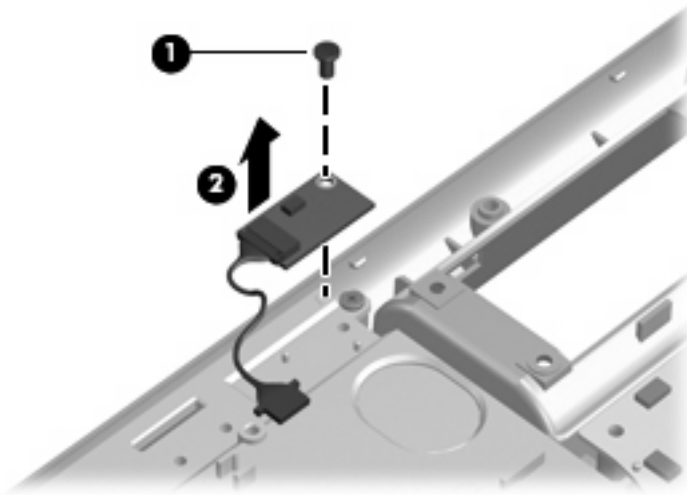

Reverse this procedure to install the display switch module.

Rear USB board

Description	Spare part number
Rear USB board (includes rear USB board cable)	449762-001

Before removing the rear USB board, follow these steps:

1. Shut down the computer. If you are unsure whether the computer is off or in Hibernation, turn the computer on, and then shut it down through the operating system.
2. Disconnect all external devices connected to the computer.
3. Disconnect the power from the computer by first unplugging the power cord from the AC outlet and then unplugging the AC adapter from the computer.
4. Remove the battery (see [Battery on page 40](#)).
5. Remove the following components:
 - a. Hard drive (see [Hard drive on page 45](#))
 - b. Optical drive (see [Optical drive on page 52](#))
 - c. Switch cover (see [Switch cover on page 54](#))
 - d. Keyboard (see [Keyboard on page 56](#))
 - e. Speaker assembly (see [Speaker assembly on page 59](#))
 - f. Display assembly (see [Display assembly on page 62](#))
 - g. Top cover (see [Top cover on page 68](#))

Remove the rear USB board:

1. Remove the two silver Phillips PM2.5×5.0 screws **(1)** that secure the power connector bracket to the computer.
2. Remove the power connector bracket **(2)**. The power connector bracket is available using spare part number 432985-001.

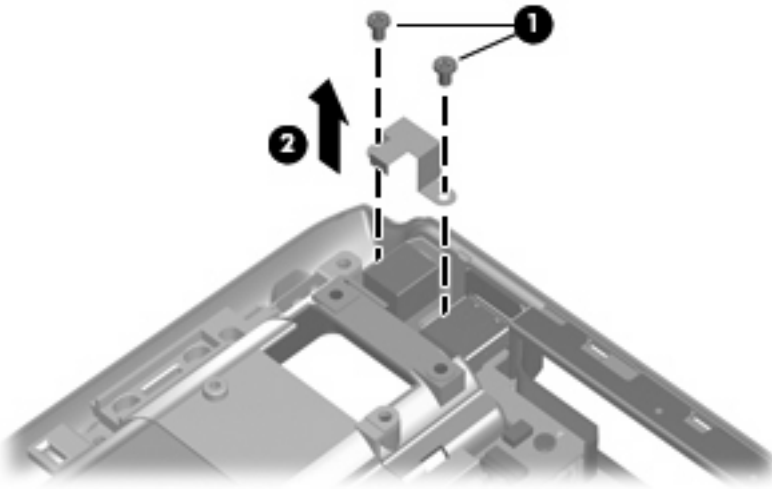

3. Remove the silver Phillips PM2.5×5.0 screw **(1)** that secures the rear USB board to the base enclosure.
4. Remove the rear USB board cable from the clips **(2)** built into the base enclosure.
5. Release the rear USB board **(3)** from the base enclosure as far as the rear USB board cable allows.
6. Disconnect the rear USB board cable **(4)** from the rear USB board.

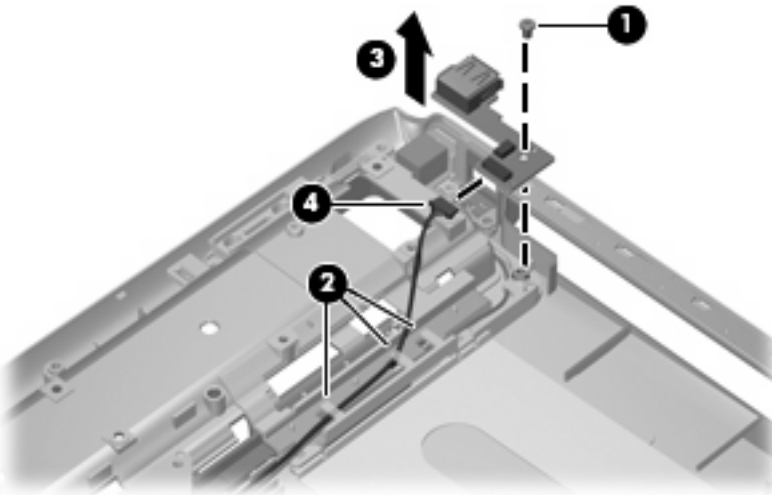

7. Remove the rear USB board.

Reverse this procedure to install the rear USB board.

System board

Description	Spare part number
System board	447984-001

Before removing the system board, follow these steps:

1. Shut down the computer. If you are unsure whether the computer is off or in Hibernation, turn the computer on, and then shut it down through the operating system.
2. Disconnect all external devices connected to the computer.
3. Disconnect the power from the computer by first unplugging the power cord from the AC outlet and then unplugging the AC adapter from the computer.
4. Remove the battery (see [Battery on page 40](#)).
5. Remove the following components:
 - a. Hard drive (see [Hard drive on page 45](#))
 - b. Optical drive (see [Optical drive on page 52](#))
 - c. Switch cover (see [Switch cover on page 54](#))
 - d. Keyboard (see [Keyboard on page 56](#))
 - e. Speaker assembly (see [Speaker assembly on page 59](#))
 - f. Display assembly (see [Display assembly on page 62](#))
 - g. Top cover (see [Top cover on page 68](#))
 - h. Wireless switch board (see [Wireless switch board on page 73](#))
 - i. Front USB board (see [Front USB board on page 77](#))
 - j. ExpressCard assembly (see [ExpressCard assembly on page 78](#))
 - k. Top cover trim (see [Top cover trim on page 80](#))
 - l. Rear USB board (see [Rear USB board on page 83](#))

When replacing the system board, be sure that the following components are removed from the defective system board and installed on the replacement system board:

- Memory modules (see [Memory module on page 47](#))
- RTC battery (see [RTC battery on page 49](#))
- WLAN module (see [WLAN module on page 50](#))
- Bluetooth module (see [Bluetooth module on page 75](#))
- ExpressCard assembly (see [ExpressCard assembly on page 78](#))
- Optical drive connector board (see [System board on page 85](#))

Remove the system board:

1. Turn the computer upside down with the front toward you.
2. Remove the Phillips PM2.5×8.0 screw that secures the system board to the base enclosure.

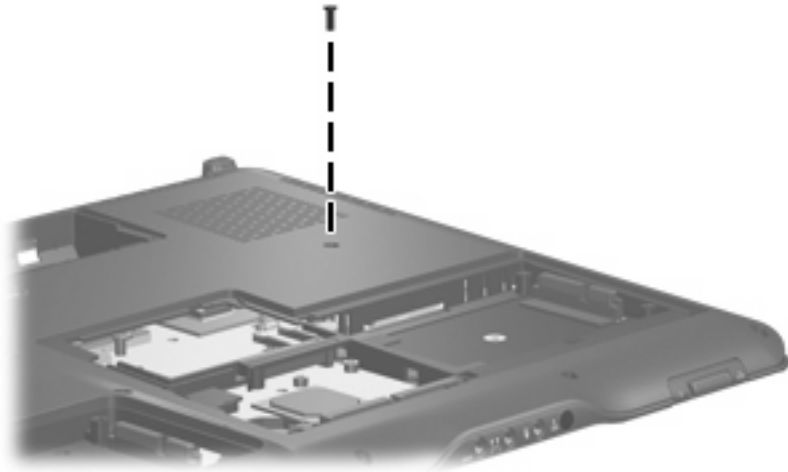

3. Turn the computer right-side up, with the front toward you.
4. Remove the three Phillips PM2.5×8.0 screws **(1)** and the three silver Phillips PM2.5×5.0 screws **(2)** that secure the system board to the base enclosure.

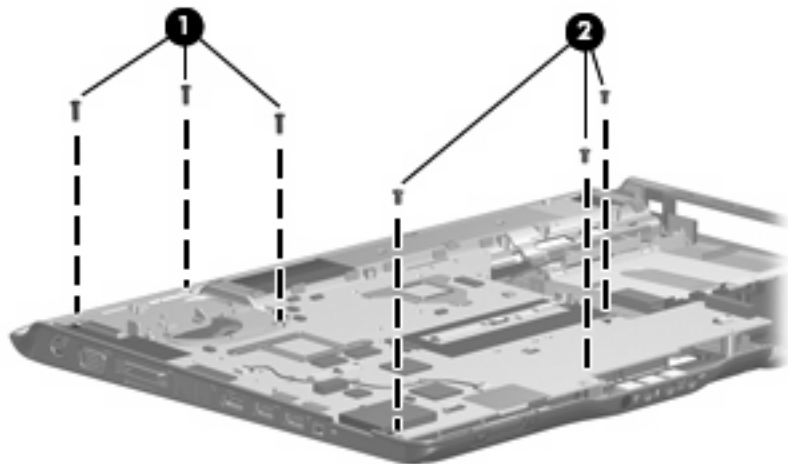

5. Remove the power connector cable **(1)** and the rear USB board cable **(2)** from the clips built into the base enclosure.

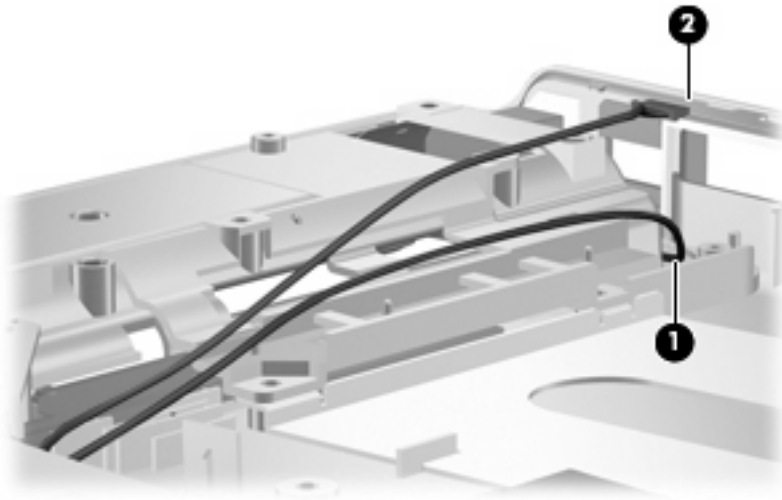

6. Use the area immediately behind the optical drive connector board **(1)** to lift the right side of the system board **(2)** until it rests at an angle.
7. Remove the optical drive connector board **(3)**. The optical drive connector board is available using spare part numbers 432985-001 and 448436-001.
8. Disconnect the audio board cable **(4)** from the system board.

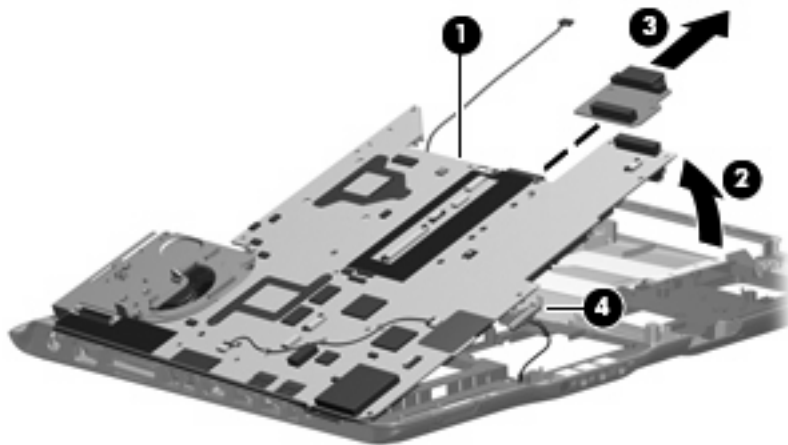

9. Disconnect the power connector cable **(1)** from the system board.

10. Remove the system board **(2)** from the base enclosure by sliding it up and to the right at an angle.

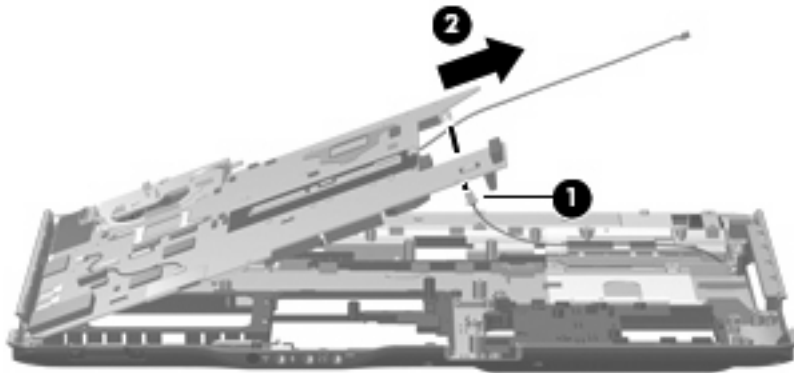

11. If it is necessary to replace the rear USB board cable, turn the system board upside down with the front toward you.
12. Disconnect the rear USB board cable from the system board. The rear USB board cable is included with the rear USB board spare part kit and is also included in the Cable Kit, spare part number 448015-001.

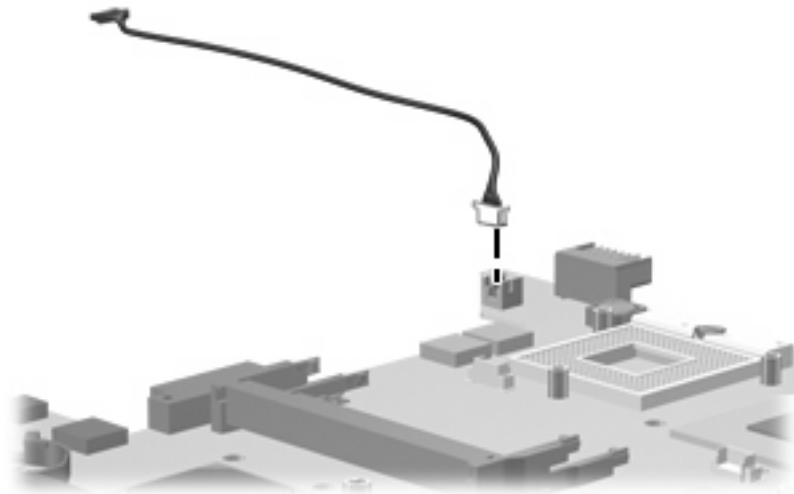

When replacing the system board, be sure that the following components are removed from the defective system board and installed on the replacement system board:

- Fan/heat sink assembly (see [Fan/heat sink assembly on page 91](#))
- Processor (see [Processor on page 94](#))

Reverse the preceding procedure to install the system board.

Audio board

Description	Spare part number
Audio board (includes audio board cable)	449763-001

Before removing the system board, follow these steps:

1. Shut down the computer. If you are unsure whether the computer is off or in Hibernation, turn the computer on, and then shut it down through the operating system.
2. Disconnect all external devices connected to the computer.
3. Disconnect the power from the computer by first unplugging the power cord from the AC outlet and then unplugging the AC adapter from the computer.
4. Remove the battery (see [Battery on page 40](#)).
5. Remove the following components:
 - a. Hard drive (see [Hard drive on page 45](#))
 - b. Optical drive (see [Optical drive on page 52](#))
 - c. Switch cover (see [Switch cover on page 54](#))
 - d. Keyboard (see [Keyboard on page 56](#))
 - e. Speaker assembly (see [Speaker assembly on page 59](#))
 - f. Display assembly (see [Display assembly on page 62](#))
 - g. Top cover (see [Top cover on page 68](#))
 - h. Wireless switch board (see [Wireless switch board on page 73](#))
 - i. Front USB board (see [Front USB board on page 77](#))
 - j. ExpressCard assembly (see [ExpressCard assembly on page 78](#))
 - k. Top cover trim (see [Top cover trim on page 80](#))
 - l. Rear USB board (see [Rear USB board on page 83](#))
 - m. System board (see [System board on page 85](#))

Remove the fan/heat assembly:

1. Remove the silver Phillips PM2.5×5.0 screw **(1)** that secures the audio board to the base enclosure.
2. Release the audio board **(2)** by sliding it back until the audio connectors disengage from the openings in the base enclosure.

3. Remove the audio board **(3)**.

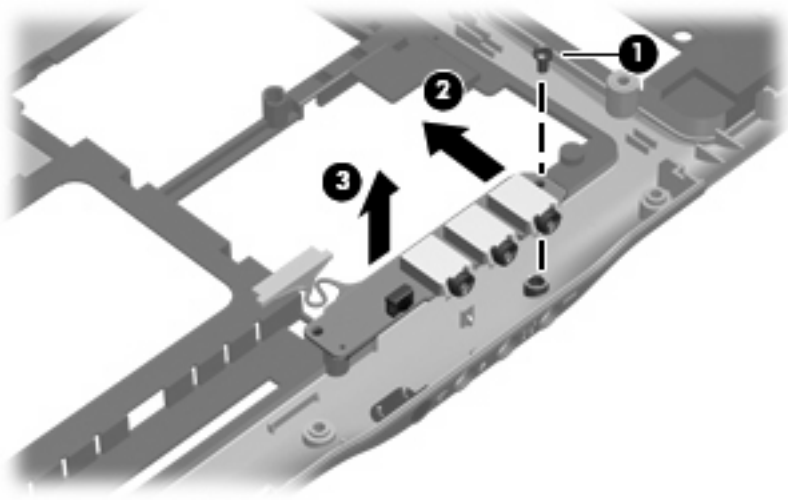

Reverse this procedure to install the audio board.

Fan/heat sink assembly

Description	Spare part number
Fan/heat sink assembly (includes heat sink and thermal material)	448016-001

 **NOTE:** When replacing the fan/heat sink assembly, be sure that the display switch module is removed from the defective fan/heat sink assembly and installed on the replacement fan/heat sink assembly. See [Display switch module on page 82](#) for display switch module removal and spare part number information.

NOTE: To properly ventilate the computer, allow at least a 7.6-cm (3-inch) clearance on the right side and rear panel of the computer. The computer uses an electric fan for ventilation. The fan is controlled by a temperature sensor and is designed to turn on automatically when high temperature conditions exist. These conditions are affected by high external temperatures, system power consumption, power management/battery conservation configurations, battery fast charging, and software applications. Exhaust air is displaced through the ventilation grill located on the left side of the computer.

Before removing the fan/heat sink assembly, follow these steps:

1. Shut down the computer. If you are unsure whether the computer is off or in Hibernation, turn the computer on, and then shut it down through the operating system.
2. Disconnect all external devices connected to the computer.
3. Disconnect the power from the computer by first unplugging the power cord from the AC outlet and then unplugging the AC adapter from the computer.
4. Remove the battery (see [Battery on page 40](#)).
5. Remove the following components:
 - a. Hard drive (see [Hard drive on page 45](#))
 - b. Optical drive (see [Optical drive on page 52](#))
 - c. Switch cover (see [Switch cover on page 54](#))
 - d. Keyboard (see [Keyboard on page 56](#))
 - e. Speaker assembly (see [Speaker assembly on page 59](#))
 - f. Display assembly (see [Display assembly on page 62](#))
 - g. Top cover (see [Top cover on page 68](#))
 - h. Wireless switch board (see [Wireless switch board on page 73](#))
 - i. Audio board (see [Audio board on page 89](#))
 - j. Front USB board (see [Front USB board on page 77](#))
 - k. Top cover trim (see [Top cover trim on page 80](#))
 - l. System board (see [System board on page 85](#))

Remove the fan/heat assembly:

1. Turn the system board upside down, with the expansion port 3 and external monitor port toward you.
2. Disconnect the fan cable **(1)** from the system board.
3. Loosen the three Phillips PM2.5×5.0 captive screws **(2)** that secure the fan/heat sink assembly to the system board.
4. Remove the fan/heat sink assembly **(3)**.

 **NOTE:** Due to the adhesive quality of the thermal material located between the fan/heat sink assembly and system board components, it may be necessary to move the fan/heat sink assembly from side to side to detach the assembly.

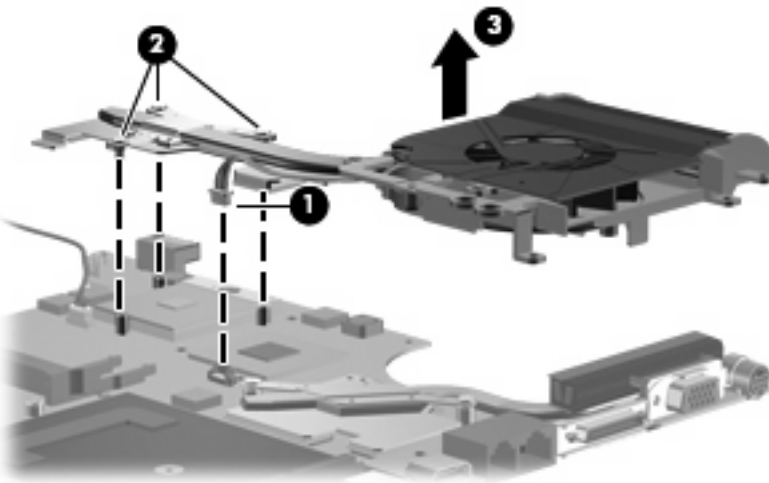

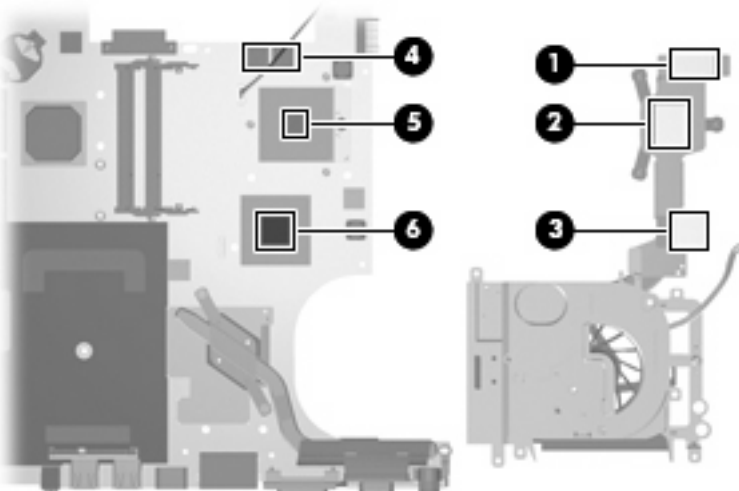

 **NOTE:** The thermal material must be thoroughly cleaned from the surfaces of the fan/heat sink assembly **(1)**, **(2)**, and **(3)**, the system board components **(4)** and **(6)**, and the processor **(5)** each time the fan/heat sink assembly is removed. Thermal material must be installed on all surfaces before the fan/heat sink assembly is reinstalled. Thermal material is included with all fan/heat sink assembly, system board, and processor spare part kits.

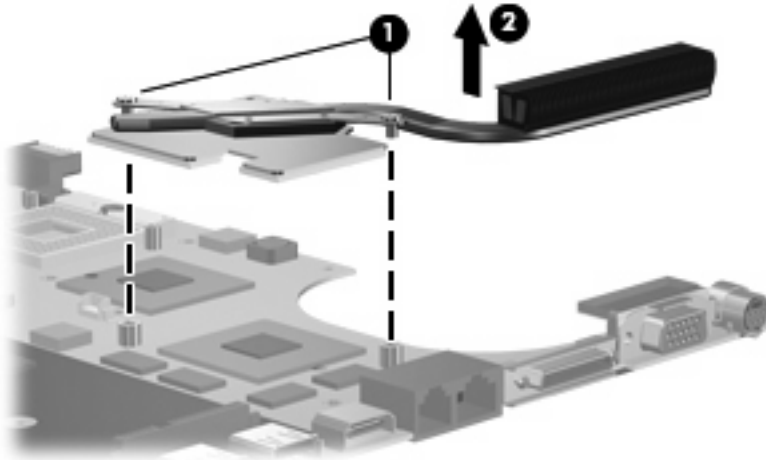

5. If it is necessary to replace the heat sink, loosen the two Phillips PM2.5×4.0 captive screws **(1)** that secure the heat sink to the system board.
6. Remove the heat sink **(2)**.

 **NOTE:** Due to the adhesive quality of the thermal material located between the heat sink and system board components, it may be necessary to move the heat sink from side to side to detach the assembly.



 **NOTE:** The thermal material must be thoroughly cleaned from the surfaces of the heat sink **(1)**, **(2)**, and **(3)**, and the system board components **(4)**, **(5)**, and **(6)** each time the heat sink is removed. Thermal material must be installed on all surfaces before the heat sink is reinstalled. Thermal material is included with all heat sink and system board spare part kits.

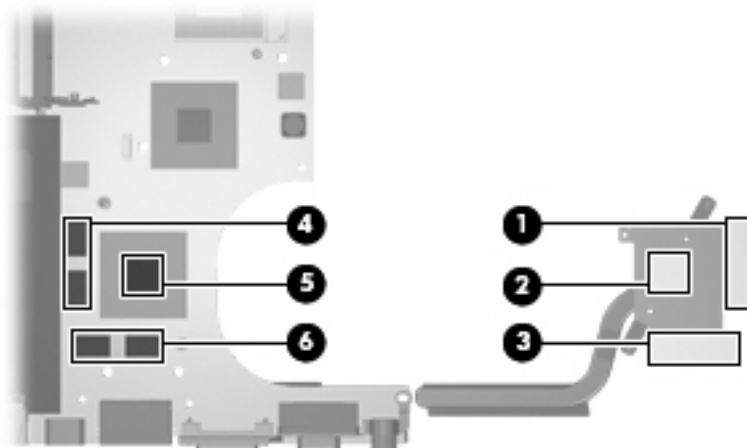

Reverse this procedure to install the fan/heat sink assembly and heat sink.

Processor

 **NOTE:** All processor spare part kits include thermal material.

Description	Spare part number
Intel Core Duo T7500 processor (2.2-GHz, 4 MB of L2 cache, 800-MHz FSB)	447985-001
Intel Core Duo T7300 processor (2.0-GHz, 4 MB of L2 cache, 800-MHz FSB)	446478-001
Intel Core Duo T7100 processor (1.8-GHz, 2 MB of L2 cache, 800-MHz FSB)	446479-001

Before removing the processor, follow these steps:

1. Shut down the computer. If you are unsure whether the computer is off or in Hibernation, turn the computer on, and then shut it down through the operating system.
2. Disconnect all external devices connected to the computer.
3. Disconnect the power from the computer by first unplugging the power cord from the AC outlet and then unplugging the AC adapter from the computer.
4. Remove the battery (see [Battery on page 40](#)).
5. Remove the following components:
 - a. Hard drive (see [Hard drive on page 45](#))
 - b. Optical drive (see [Optical drive on page 52](#))
 - c. Switch cover (see [Switch cover on page 54](#))
 - d. Keyboard (see [Keyboard on page 56](#))
 - e. Speaker assembly (see [Speaker assembly on page 59](#))
 - f. Display assembly (see [Display assembly on page 62](#))
 - g. Top cover (see [Top cover on page 68](#))
 - h. Wireless switch board (see [Wireless switch board on page 73](#))
 - i. Audio board (see [Audio board on page 89](#))
 - j. Front USB board (see [Front USB board on page 77](#))
 - k. Top cover trim (see [Top cover trim on page 80](#))
 - l. System board (see [System board on page 85](#))
 - m. Fan/heat sink assembly (see [Fan/heat sink assembly on page 91](#))

Remove the processor:

1. Turn the processor locking screw **(1)** one-half turn counterclockwise until you hear a click.

- Lift the processor **(2)** straight up and remove it.

 **NOTE:** The gold triangle **(3)** on the processor must be aligned with the triangle icon **(4)** embossed on the processor slot when you install the processor.

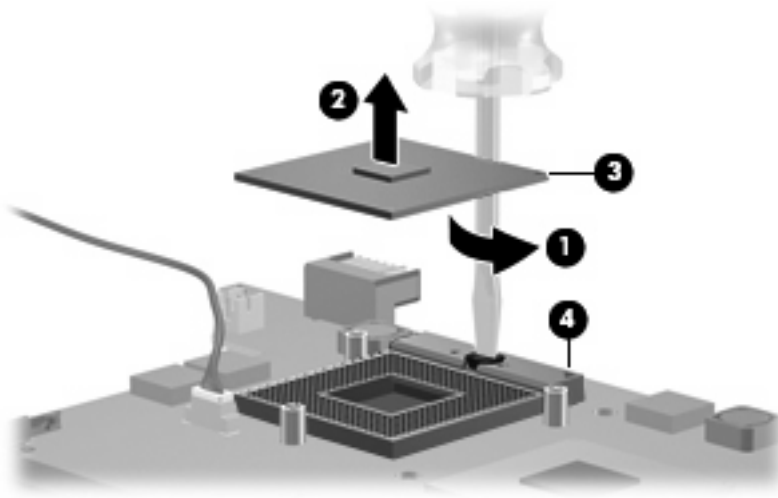

Reverse this procedure to install the processor.

5 Setup Utility

⚠ **WARNING!** Only authorized technicians trained by HP must repair this equipment. All troubleshooting and repair procedures are detailed to allow repair at only the subassembly or module level. Because of the complexity of the individual boards and subassemblies, do not attempt to make repairs at the component level or modify any printed wiring board. Improper repairs can create a safety hazard. Any indication of component replacement or printed wiring board modification may void any warranty or exchange allowances.

Starting the Setup Utility

The Setup Utility is a ROM-based information and customization utility that can be used even when your Windows operating system is not working or will not load.

📝 **NOTE:** The fingerprint reader (select models only) does not work when accessing the Setup Utility.

The utility reports information about the computer and provides settings for startup, security, and other preferences.

To start the Setup Utility:

1. Turn on or restart the computer.
2. Before Windows opens and while “Press <F10> to enter setup” is displayed in the lower-left corner of the screen, press **f10**.

Changing the language of the Setup Utility

The following procedure explains how to change the language of the Setup Utility. If the Setup Utility is not already running, begin at step 1. If the Setup Utility is already running, begin at step 2.

1. To start the Setup Utility, turn on or restart the computer, and then press **f10** while “Press <f10> to enter setup” is displayed in the lower-left corner of the screen.
2. Use the arrow keys to select **System Configuration > Language**, and then press **enter**.
3. Press **f5** or **f6** (or use the arrow keys) to select a language, and then press **enter** to select a language.
4. When a confirmation prompt with your preference selected is displayed, press **enter** to save your preference.
5. To set your preferences and exit the Setup Utility, press **f10** and then follow the instructions on the screen.

Your preferences go into effect when the computer restarts in Windows.

Navigating and selecting in the Setup Utility

Because the Setup Utility is not Windows-based, it does not support the TouchPad. Navigation and selection are by keystroke.

- To choose a menu or a menu item, use the arrow keys.
- To choose an item in a drop-down list or to toggle a field, for example an Enable/Disable field, use either the arrow keys or **f5** or **f6**.
- To select an item, press **enter**.
- To close a text box or return to the menu display, press **esc**.
- To display additional navigation and selection information while the Setup Utility is open, press **f1**.

Displaying system information

The following procedure explains how to display system information in the Setup Utility. If the Setup Utility is not open, begin at step 1. If the Setup Utility is open, begin at step 2.

1. To start the Setup Utility, turn on or restart the computer, and then press **f10** while “Press to enter setup” is displayed in the lower-left corner of the screen.
2. Access the system information by using the **Main** menu.
3. To exit the Setup Utility without changing any settings, use the arrow keys to select **Exit > Exit Discarding Changes**, and then press **enter**. (The computer restarts in Windows.)

Restoring default settings in the Setup Utility

The following procedure explains how to restore the Setup Utility default settings. If the Setup Utility is not already running, begin at step 1. If the Setup Utility is already running, begin at step 2.

1. To start the Setup Utility, turn on or restart the computer, and then press **f10** while “Press to enter setup” is displayed in the lower-left corner of the screen.
2. Select **Exit > Load Setup Defaults**, and then press **enter**.
3. When the Setup Confirmation is displayed, press **enter** to save your preferences.
4. To set your preferences and exit the Setup Utility, press **f10**, and then follow the instructions on the screen.

The Setup Utility default settings are set when you exit the Setup Utility and go into effect when the computer restarts.

 **NOTE:** Your password, security, and language settings are not changed when you restore the factory default settings.

Using advanced Setup Utility features

This section describes the Setup Utility features recommended for all users. For more information about the Setup Utility features recommended for advanced users only, refer to Help and Support, which is accessible only when the computer is in Windows.

The Setup Utility features available for advanced users include a hard drive self-test, a Network Service Boot, and settings for boot order preferences.

The “<F12> to boot from LAN” message that is displayed in the lower-left corner of the screen each time the computer is started or restarted in Windows is the prompt for a Network Service Boot.

The “Press <ESC> to change boot order” message that is displayed in the lower-left corner of the screen each time the computer is started or restarted in Windows is the prompt to change the boot order.

Closing the Setup Utility

You can close the Setup Utility with or without saving changes.

- To close the Setup Utility and save your changes from the current session, use either of the following procedures:
 - Press **f10**, and then follow the instructions on the screen.
 - or—
 - If the Setup Utility menus are not visible, press **esc** to return to the menu display. Then use the arrow keys to select **Exit > Exit Saving Changes**, and then press **enter**.

When you use the **f10** procedure, you are offered an option to return to the Setup Utility. When you use the Exit Saving Changes procedure, the Setup Utility closes when you press **enter**.

- To close the Setup Utility without saving your changes from the current session:

If the Setup Utility menus are not visible, press **esc** to return to the menu display. Then use the arrow keys to select **Exit > Exit Discarding Changes**, and then press **enter**.

After the Setup Utility closes, the computer restarts in Windows.

Setup Utility menus

The menu tables in this section provide an overview of Setup Utility options.

 **NOTE:** Some of the Setup Utility menu items listed in this section may not be supported by your computer.

Main menu

Select	To do this
System information	<ul style="list-style-type: none">• View and change the system time and date.• View identification information about the computer.• View specification information about the processor, memory size, system BIOS, and keyboard controller version (select models only).

Security menu

Select	To do this
Administrator password	Enter, change, or delete an administrator password.
Power-On Password	Enter, change, or delete a power-on password.

System Configuration menu

Select	To do this
Language Support	Change the Setup Utility language.
Enhanced SATA support (select models only)	Enable/disable enhanced SATA mode.
Boot Options	Set the following boot options: <ul style="list-style-type: none">• f10 and f12 Delay (sec.)—Set the delay for the f10 and f12 functions of the Setup Utility in intervals of 5 seconds each (0, 5, 10, 15, 20).• CD-ROM boot—Enable/disable boot from CD-ROM.• Floppy boot—Enable/disable boot from Floppy.• Internal Network Adapter boot—Enable/disable boot from Internal Network Adapter.• Boot Order—Set the boot order for:<ul style="list-style-type: none">◦ USB Floppy◦ ATAPI CD/DVD ROM Drive◦ Hard drive◦ USB Diskette on Key◦ USB Hard drive◦ Network adapter
Button Sound (select models only)	Enable/disable the Quick Launch Button tapping sound.
Video memory up to (select models only)	Select the amount of video memory.

Diagnostics menu

Select	To do this
Hard Disk Self Test	Run a comprehensive self-test on the hard drive. NOTE: On models with two hard drives, this menu option is called the Primary Hard Disk Self Test .
Secondary Hard Disk Self Test (select models only)	Run a comprehensive self-test on a secondary hard drive.

6 Specifications

Computer specifications

	Metric	U.S.
Dimensions		
Height (front to back)	3.16 to 4.18 cm	1.26 to 1.65 in
Width	39.60 cm	15.59 in
Depth	28.50 cm	11.22 in
Weight (with optical drive, hard drive, and battery)	3.54 kg	7.80 lbs
Second hard drive adds:	0.13 kg	0.28 lbs
Camera adds:	0.009 kg	0.02 lbs
Input power		
Operating voltage	18.5 V dc @ 3.5 A - 65 W	
Operating current	3.5 A or 4.74 A	
Temperature		
Operating (not writing to optical disc)	0°C to 35°C	32°F to 95°F
Operating (writing to optical disc)	5°C to 35°C	41°F to 95°F
Nonoperating	-20°C to 60°C	-4°F to 140°F
Relative humidity		
Operating	10% to 90%	
Nonoperating	5% to 95%	
Maximum altitude (unpressurized)		
Operating (14.7 to 10.1 psia)	-15 m to 3,048 m	-50 ft to 10,000 ft
Nonoperating (14.7 to 4.4 psia)	-15 m to 12,192 m	-50 ft to 40,000 ft
Shock		
Operating	125 g, 2 ms, half-sine	
Nonoperating	200 g, 2 ms, half-sine	
Random vibration		

	Metric	U.S.
Operating	0.75 g zero-to-peak, 10 Hz to 500 Hz, 0.25 oct/min sweep rate	
Nonoperating	1.50 g zero-to-peak, 10 Hz to 500 Hz, 0.5 oct/min sweep rate	

NOTE: Applicable product safety standards specify thermal limits for plastic surfaces. The computer operates well within this range of temperatures.

15.4-inch, SXGA+ display specifications

	Metric	U.S.
Dimensions		
Height	23.00 cm	9.06 in
Width	36.90 cm	14.49 in
Diagonal	43.40 cm	17.09 in
Number of colors	Up to 16.8 million	
Contrast ratio	200:1 (typical)	
Brightness	180 nits (typical)	
Pixel resolution		
Pitch	0.197 × 0.197 mm	
Format	1680 × 1050	
Configuration	RGB vertical stripe	
Backlight	Edge lit	
Character display	80 × 25	
Total power consumption	4 W	
Viewing angle	+/-65° horizontal, +/-50° vertical (typical)	

15.4-inch WXGA+ display specifications

	Metric	U.S.
Dimensions		
Height	23.00 cm	9.06 in
Width	36.90 cm	14.49 in
Diagonal	43.40 cm	17.09 in
Number of colors	Up to 16.8 million	
Contrast ratio	200:1	
Brightness	180 nits typical	
Pitch resolution		
Pitch	0.259 × 0.259 mm	
Format	1280 × 800	
Configuration	RGB vertical stripe	
Backlight	Edge lit	
Character display	80 × 25	
Total power consumption	4 W	
Viewing angle	+/-40° horizontal, +20/-40° vertical typical	

Hard drive specifications

	200-GB*	160-GB*	120-GB*	100-GB*	80-GB*
Dimensions					
Height	9.5 mm	9.5 mm	9.5 mm	9.5 mm	9.5 mm
Width	70 mm	70 mm	70 mm	70 mm	70 mm
Weight	101 g	101 g	101 g	101 g	101 g
Interface type					
	ATA-7	ATA-7	ATA-7	ATA-7	ATA-7
Transfer rate					
Synchronous (maximum)	100 MB/sec	100 MB/sec	100 MB/sec	100 MB/sec	100 MB/sec
Security	ATA security	ATA security	ATA security	ATA security	ATA security
Seek times (typical read, including setting)					
Single track	3 ms	3 ms	3 ms	3 ms	3 ms
Average	13 ms	13 ms	13 ms	13 ms	13 ms
Maximum	24 ms	24 ms	24 ms	24 ms	24 ms
Logical blocks					
	396,532,124	317,249,699	237,937,274	198,281,062	158,624,849
Disc rotational speed					
	4200-rpm	5400-rpm	5400-rpm	7200-rpm	5400-rpm
Operating temperature					
	5°C to 55°C (41°F to 131°F)				
*1 GB = 1 billion bytes when referring to hard drive storage capacity. Actual accessible capacity is less.					
NOTE: Certain restrictions and exclusions apply. Contact technical support for details.					

DVD±RW and CD-RW Super Multi Double-Layer Combo Drive specifications

Applicable disc	Read:	Write:
	CD-DA, CD+(E)G, CD-MIDI, CD-TEXT, CD-ROM, CD-ROM XA, MIXED MODE CD, CD-I, CD-I Bridge (Photo-CD, Video CD), Multisession CD (Photo-CD, CD-EXTRA, Portfolio, CD-R, CD-RW), CD-R, CD-RW, DVD-ROM (DVD-5, DVD-9, DVD-10, DVD-18), DVD-R, DVD-RW, DVD+R, DVD+RW, DVD-RAM	CD-R and CD-RW DVD+R, DVD+RW, DVD-R, DVD-RW, DVD-RAM
Center hole diameter	1.5 cm (0.59 in)	
Disc diameter		
Standard disc	12 cm (4.72 in)	
Mini disc	8 cm (3.15 in)	
Disc thickness	1.2 mm (0.047 in)	
Track pitch	0.74 μ m	
Access time	CD	DVD
Random	< 175 ms	< 230 ms
Full stroke	< 285 ms	< 335 ms
Audio output level	Audio-out, 0.7 Vrms	
Cache buffer	2 MB	
Data transfer rate		
24X CD-ROM	3,600 KB/sec	
8X DVD	10,800 KB/sec	
24X CD-R	3,600 KB/sec	
16X CD-RW	2,400 KB/sec	
8X DVD+R	10,800 KB/sec	
4X DVD+RW	5,400 KB/sec	
8X DVD-R	10,800 KB/sec	
4X DVD-RW	5,400 KB/sec	
2.4X DVD+R(9)	2,700 KB/sec	
5X DVD-RAM	6,750 KB/sec	
Transfer mode	Multiword DMA Mode	
Startup time	< 15 seconds	
Stop time	< 6 seconds	

System DMA specifications

Hardware DMA	System function
DMA0	Not applicable
DMA1*	Not applicable
DMA2*	Not applicable
DMA3	Not applicable
DMA4	Direct memory access controller
DMA5*	Available for PC Card
DMA6	Not assigned
DMA7	Not assigned

*PC Card controller can use DMA 1, 2, or 5.

System interrupt specifications

Hardware IRQ	System function
IRQ0	System timer
IRQ1	Standard 101-/102-Key or Microsoft® Natural Keyboard
IRQ2	Cascaded
IRQ3	Intel 82801DB/DBM USB2 Enhanced Host Controller—24CD
IRQ4	COM1
IRQ5*	Conexant AC—Link Audio Intel 82801DB/DBM SMBus Controller—24C3 Data Fax Modem with SmartCP
IRQ6	Diskette drive
IRQ7*	Parallel port
IRQ8	System CMOS/real-time clock
IRQ9*	Microsoft ACPI-compliant system
IRQ10*	Intel USB UHCI controller—24C2 Intel 82852/82855 GM/GME Graphic Controller Realtek RTL8139 Family PCI Fast Ethernet Controller
IRQ11	Intel USB EHCI controller—24CD Intel USB UHCI controller—24C4 Intel USB UHCI controller—24C7 Intel Pro/Wireless 2200BG TI OHCI 1394 host controller TI PCI1410 CardBus controller
IRQ12	Synaptics PS/2 TouchPad
IRQ13	Numeric data processor
IRQ14	Primary IDE channel
IRQ15	Secondary IDE channel

*Default configuration; audio possible configurations are IRQ5, IRQ7, IRQ9, IRQ10, or none.

NOTE: PC Cards may assert IRQ3, IRQ4, IRQ5, IRQ7, IRQ9, IRQ10, IRQ11, or IRQ15. Either the infrared or the serial port may assert IRQ3 or IRQ4.

System I/O address specifications

I/O address (hex)	System function (shipping configuration)
000 - 00F	DMA controller no. 1
010 - 01F	Unused
020 - 021	Interrupt controller no. 1
022 - 024	Opti chipset configuration registers
025 - 03F	Unused
02E - 02F	87334 "Super I/O" configuration for CPU
040 - 05F	Counter/timer registers
044 - 05F	Unused
060	Keyboard controller
061	Port B
062 - 063	Unused
064	Keyboard controller
065 - 06F	Unused
070 - 071	NMI enable/RTC
072 - 07F	Unused
080 - 08F	DMA page registers
090 - 091	Unused
092	Port A
093 - 09F	Unused
0A0 - 0A1	Interrupt controller no. 2
I/O Address (hex)	System Function (shipping configuration)
0A2 - 0BF	Unused
0C0 - 0DF	DMA controller no. 2
0E0 - 0EF	Unused
0F0 - 0F1	Coprocessor busy clear/reset
0F2 - 0FF	Unused
100 - 16F	Unused
170 - 177	Secondary fixed disk controller
178 - 1EF	Unused
1F0 - 1F7	Primary fixed disk controller
1F8 - 200	Unused
201	JoyStick (decoded in ESS1688)
202 - 21F	Unused

I/O address (hex)	System function (shipping configuration)
220 - 22F	Entertainment audio
230 - 26D	Unused
26E - 26	Unused
278 - 27F	Unused
280 - 2AB	Unused
2A0 - 2A7	Unused
2A8 - 2E7	Unused
2E8 - 2EF	Reserved serial port
2F0 - 2F7	Unused
2F8 - 2FF	Infrared port
300 - 31F	Unused
320 - 36F	Unused
370 - 377	Secondary diskette drive controller
378 - 37F	Parallel port (LPT1/default)
380 - 387	Unused
388 - 38B	FM synthesizer—OPL3
38C - 3AF	Unused
3B0 - 3BB	VGA
3BC - 3BF	Reserved (parallel port/no EPP support)
3C0 - 3DF	VGA
3E0 - 3E1	PC Card controller in CPU
3E2 - 3E3	Unused
3E8 - 3EF	Internal modem
3F0 - 3F7	"A" diskette controller
3F8 - 3FF	Serial port (COM1/default)
CF8 - CFB	PCI configuration index register (PCIDIVO-1)
CFC - CFF	PCI configuration data register (PCIDIVO-1)

System memory map specifications

Size	Memory address	System function
640 KB	00000000-0009FFFF	Base memory
128 KB	000A0000-000BFFFF	Video memory
48 KB	000C0000-000CBFFF	Video BIOS
160 KB	000C8000-000E7FFF	Unused
64 KB	000E8000-000FFFFF	System BIOS
15 MB	00100000-00FFFFFF	Extended memory
58 MB	04800000-07FFFFFF	Super extended memory
58 MB	04800000-07FFFFFF	Unused
2 MB	08000000-080FFFFF	Video memory (direct access)
4 GB	08200000-FFFEFFFF	Unused
64 KB	FFF0000-FFFFFFFF	System BIOS

7 Screw listing

This section provides specification and reference information for the screws and screw locks used in the computer. All screws and screw locks listed in this section are available in the Screw Kit, spare part number 441140-001, and the Display Screw Kit, spare part number 441124-001.

Phillips PM2.5×8.0 captive screw

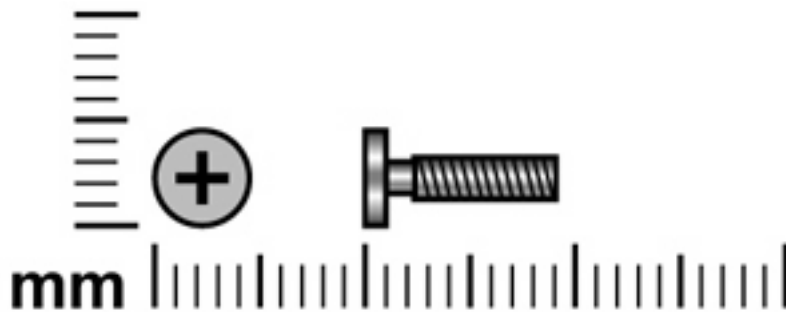

Color	Quantity	Length	Thread	Head width
Black	4	8.0 mm	2.4 mm	5.0 mm

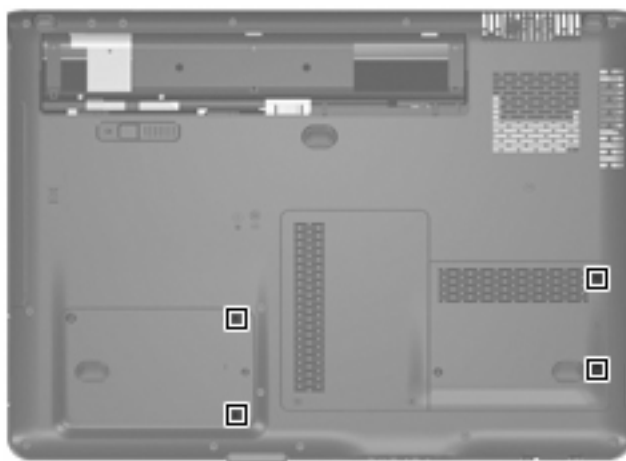

Where used:

4 captive screws (secured by C-clips) that secure the hard drive covers to the computer

Phillips PM3.0×4.0 screw

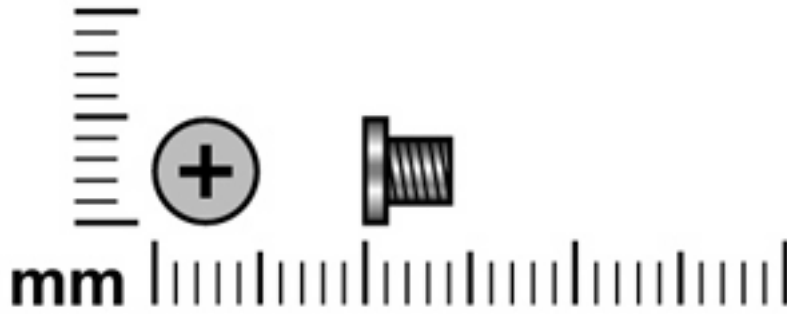

Color	Quantity	Length	Thread	Head width
Silver	8	4.0 mm	3.0 mm	5.0 mm



Where used: 8 screws that secure the hard drive brackets to the hard drives

Phillips PM2.5×5.0 captive screw

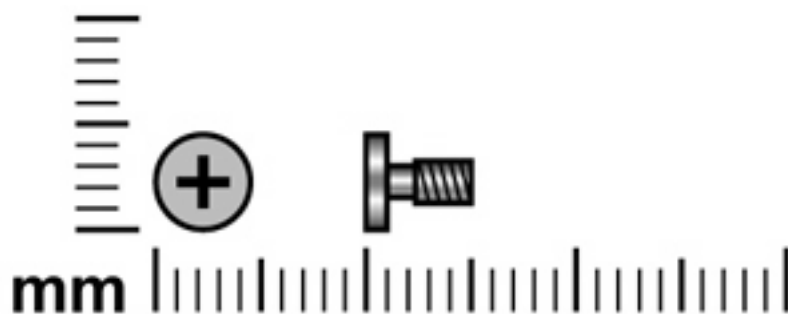

Color	Quantity	Length	Thread	Head width
Black	5	5.0 mm	2.5 mm	5.0 mm

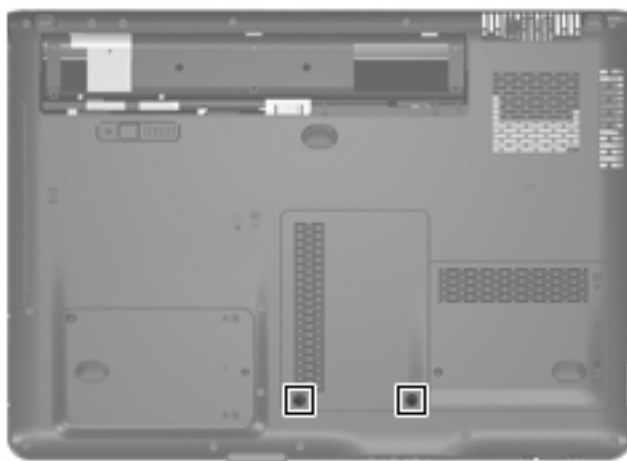

Where used: 2 captive screws (secured by C-clips) that secure the memory/WLAN module compartment cover to the computer

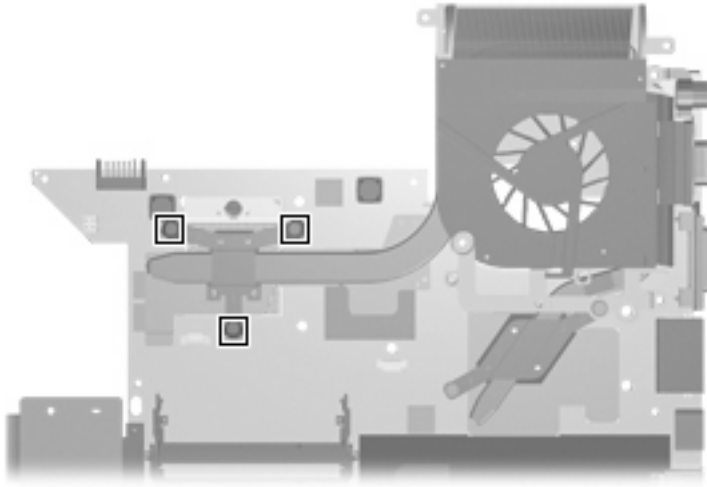

Where used: 3 captive screws that secure the fan/heat sink assembly to the computer

Phillips PM2.0×11.0 screw

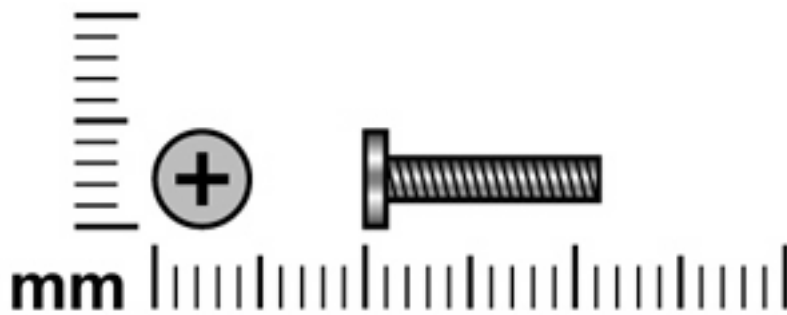

Color	Quantity	Length	Thread	Head width
Silver	2	11.0 mm	2.0 mm	5.0 mm

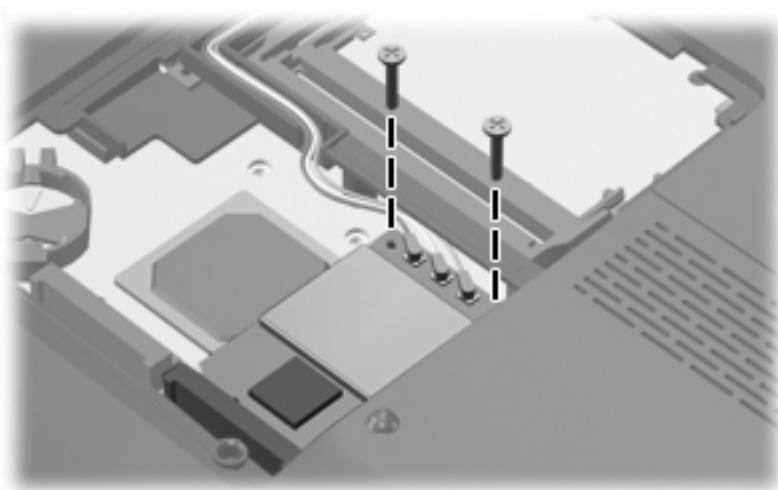

Where used:

2 screws that secure the WLAN module to the computer

Phillips PM2.5×8.0 screw

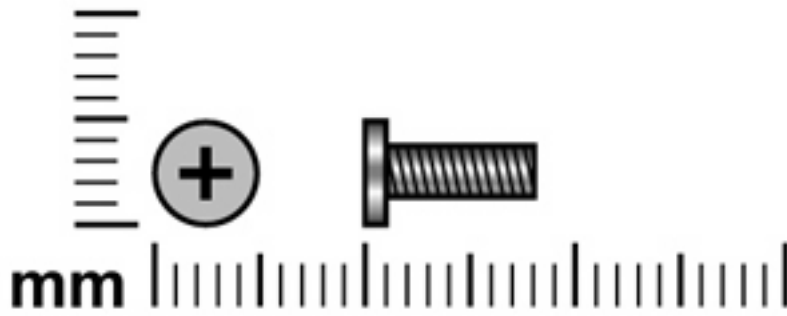

Color	Quantity	Length	Thread	Head width
Black	37	8.0 mm	2.5 mm	5.0 mm

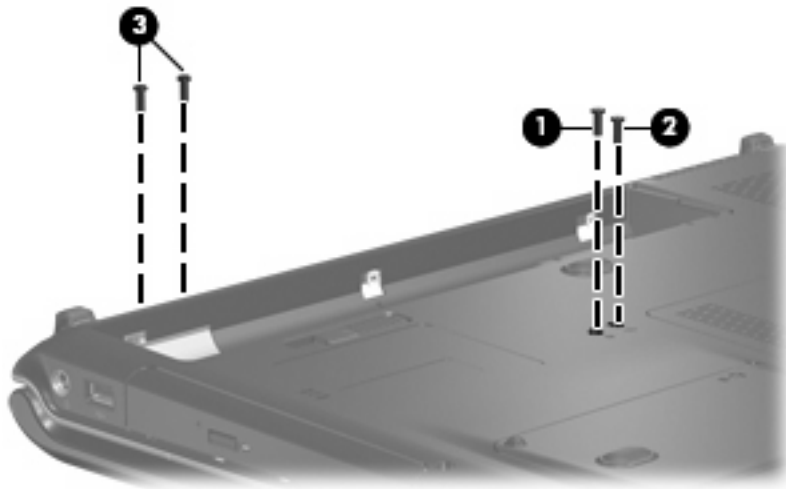

Where used:

- (1) One screw that secures the optical drive to the computer
- (2) One screw that secures the keyboard to the computer
- (3) Two screws that secure the display assembly to the computer

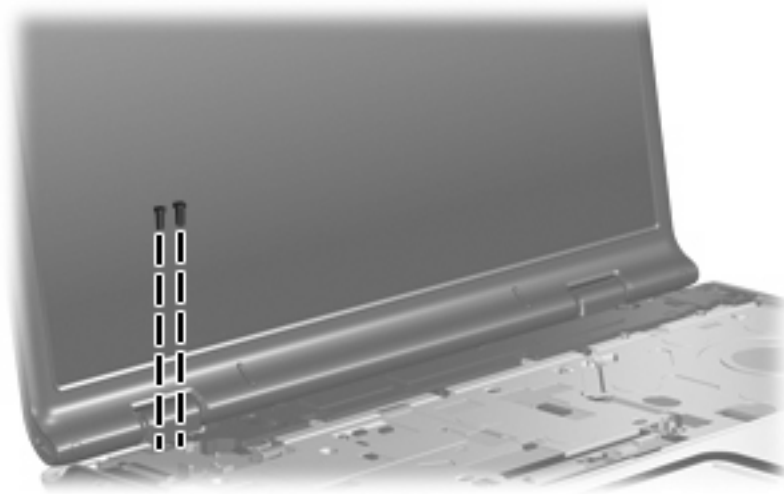

Where used: 2 screws that secure the display assembly to the computer

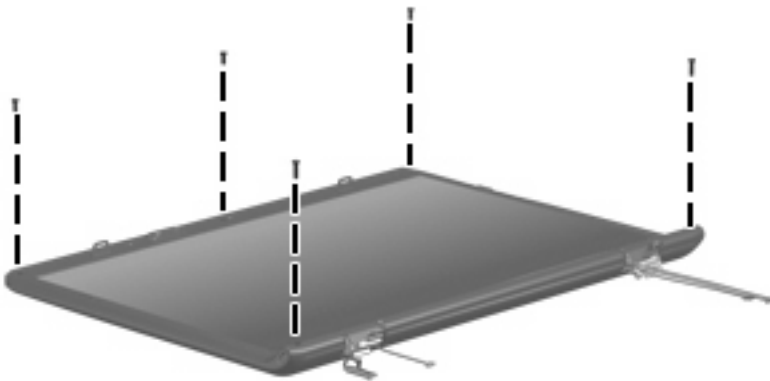

Where used: 5 screws that secure the display bezel to the display computer

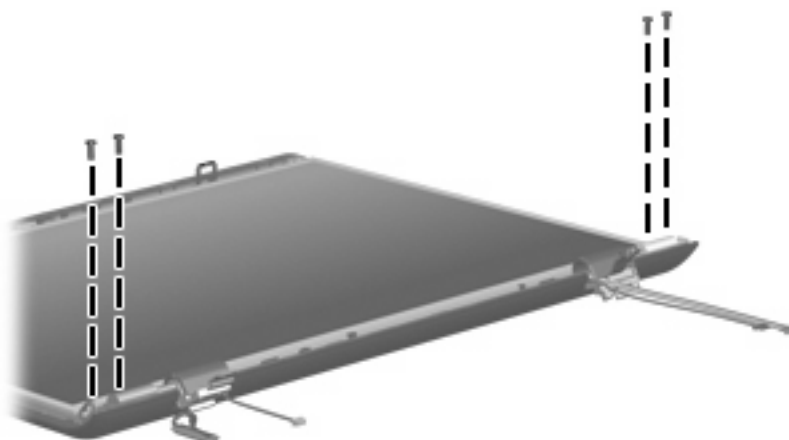

Where used: 4 screws that secure the display panel to the display enclosure

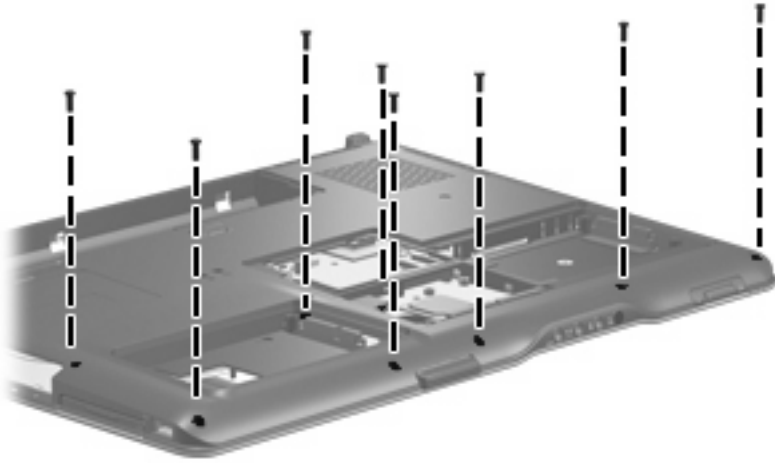

Where used: 8 screws that secure the top cover to the computer

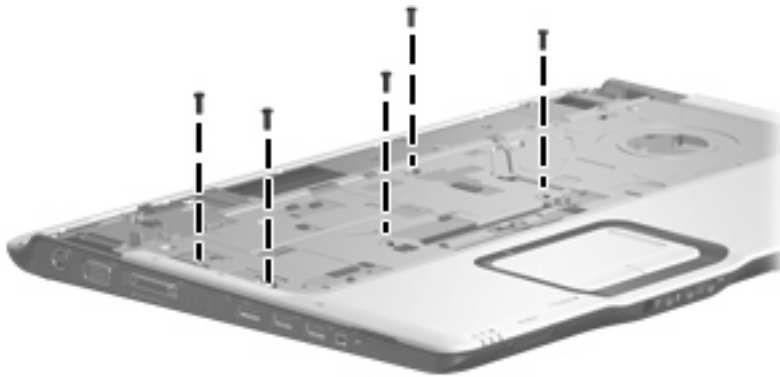

Where used: 5 screws that secure the top cover to the computer

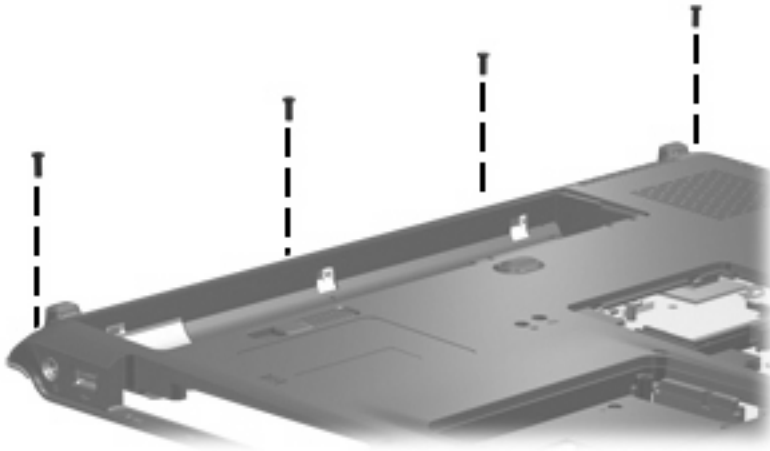

Where used: 4 screws that secure the top cover trim to the computer

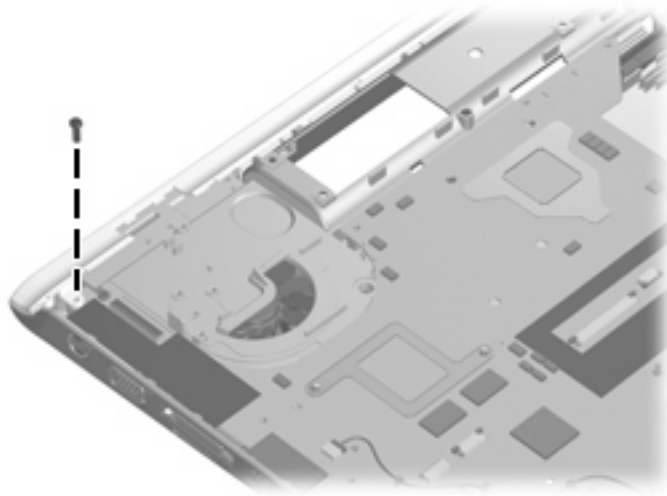

Where used: One screw that secures the top cover trim to the computer

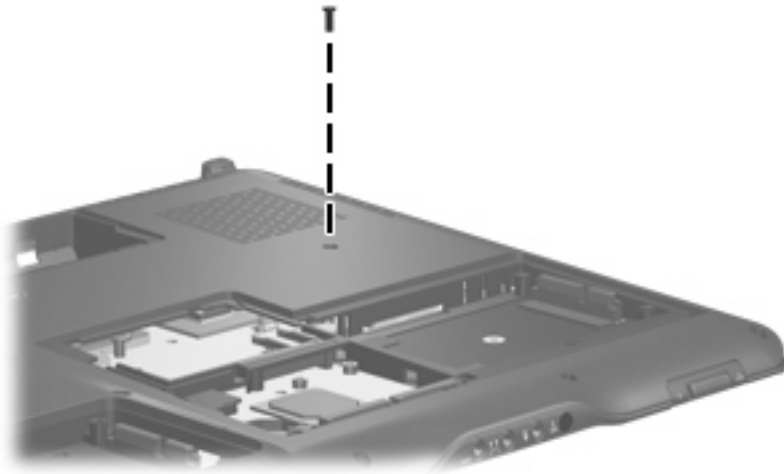

Where used: One screw that secures the system board to the computer

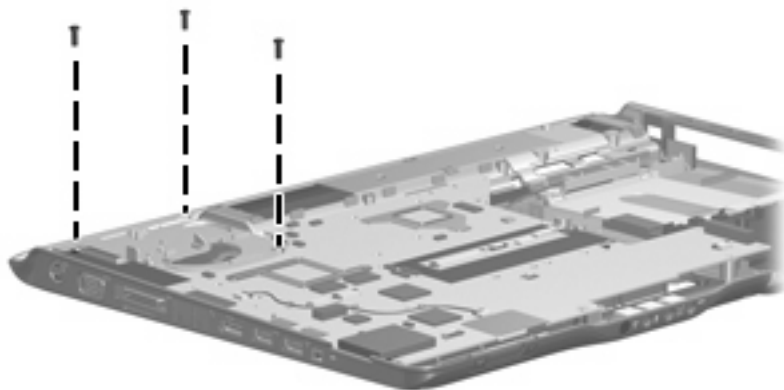

Where used: 3 screws that secure the system board to the computer

Phillips PM2.0×3.0 screw

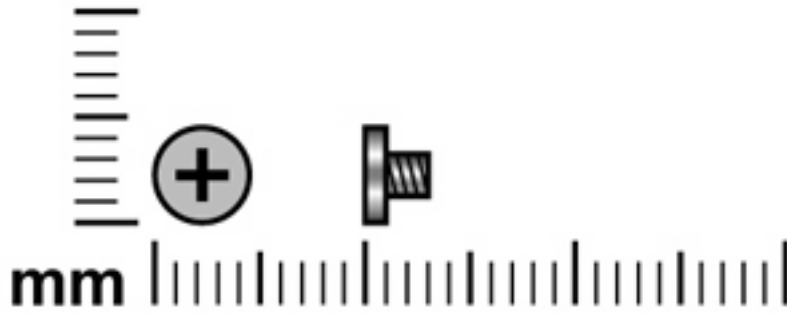

Color	Quantity	Length	Thread	Head width
Silver	8	3.0 mm	2.0 mm	4.0 mm

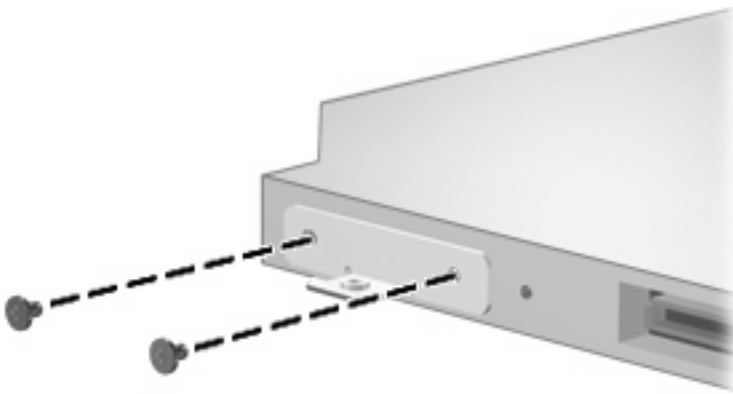

Where used: 2 screws that secure the optical drive bracket to the optical drive

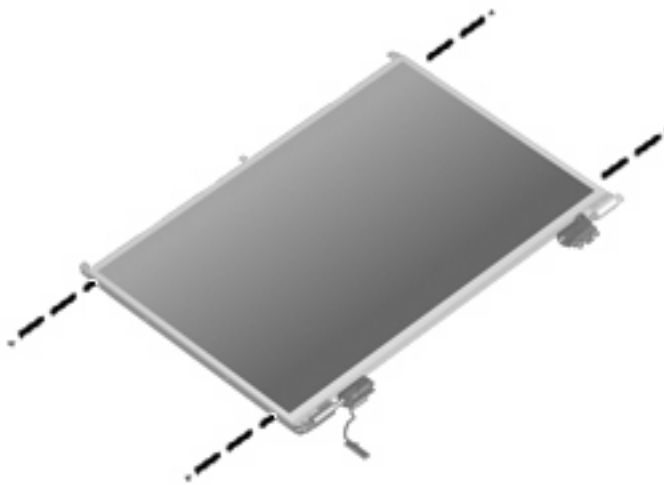

Where used: 4 screws that secure the display hinges to the display panel

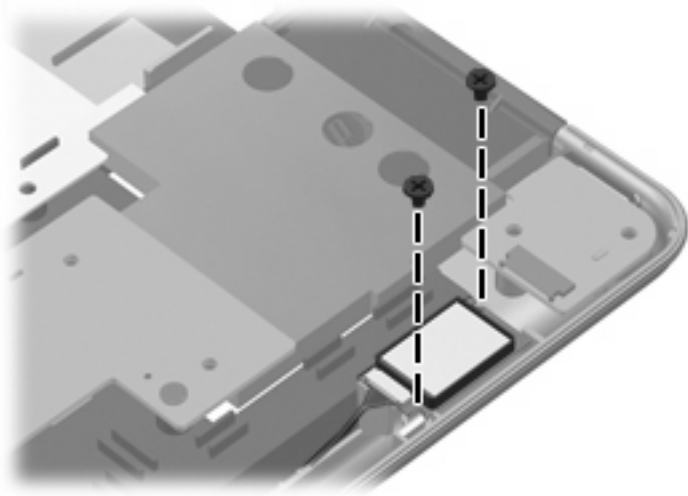

Where used: 2 screws that secure the Bluetooth module to the system board

Phillips PM2.5×5.0 screw

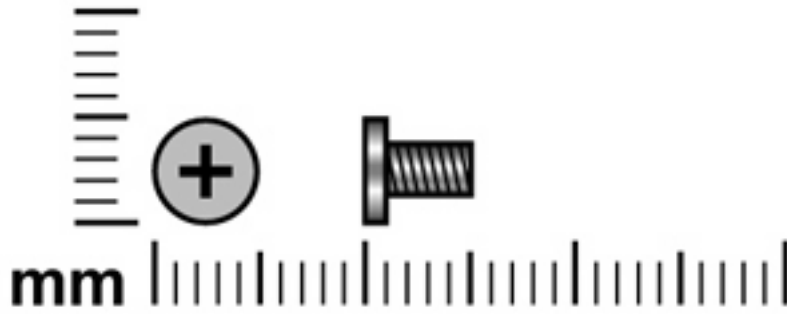

Color	Quantity	Length	Thread	Head width
Silver	35	5.0 mm	2.5 mm	5.0 mm

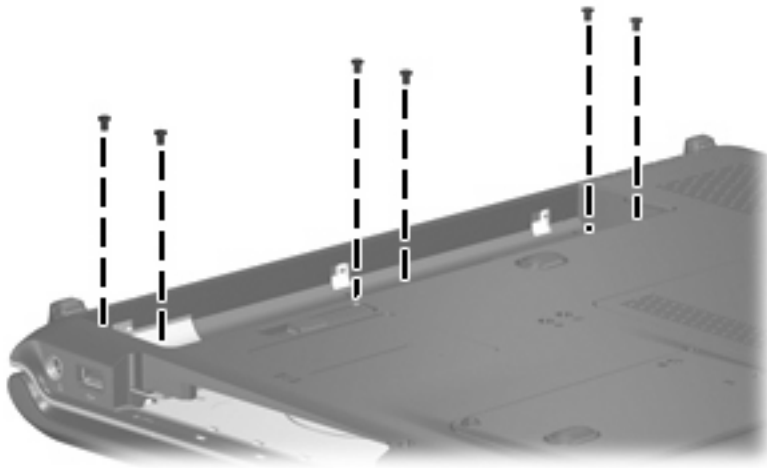

Where used: 6 screws that secure the switch cover to the computer

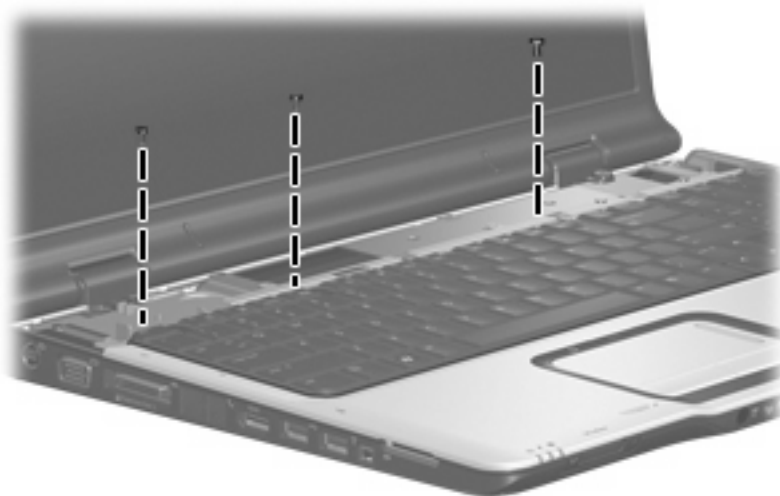

Where used: 3 screws that secure the keyboard to the computer

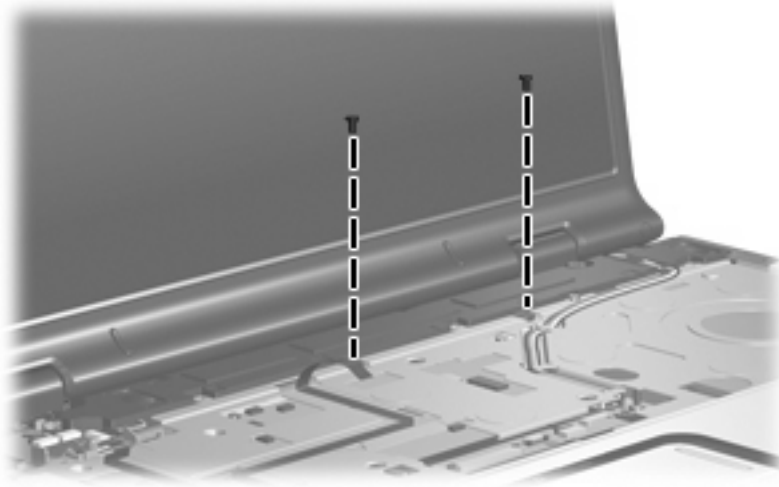

Where used: 2 screws that secure the speaker to the computer

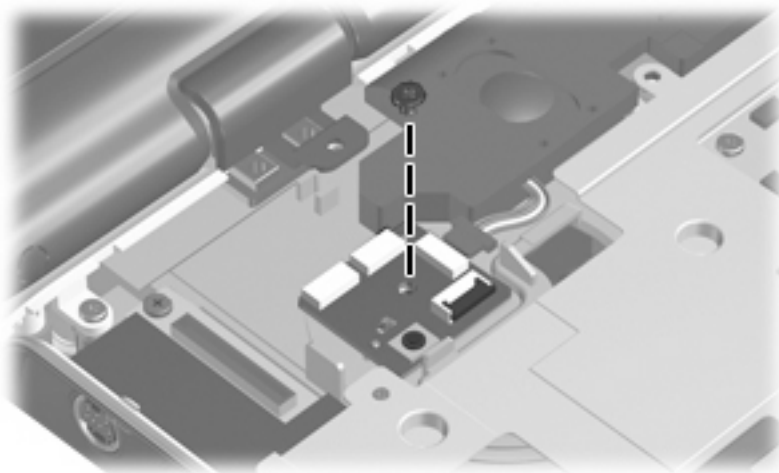

Where used: One screw that secures the power button board to the computer

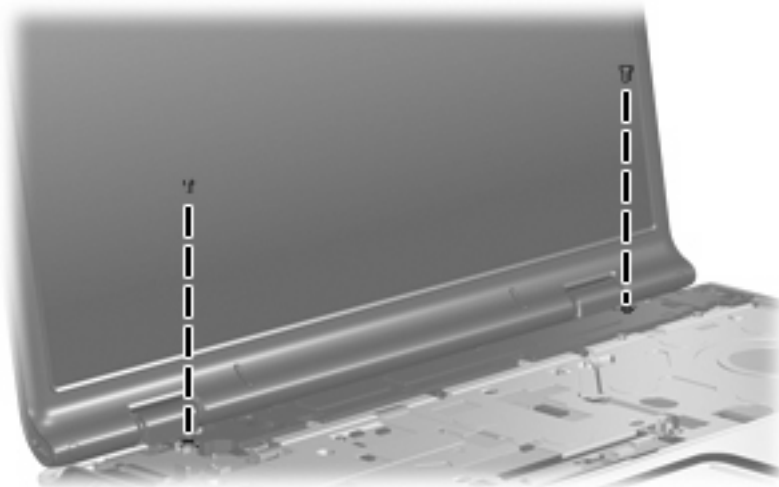

Where used: 2 screws that secure the display assembly to the computer

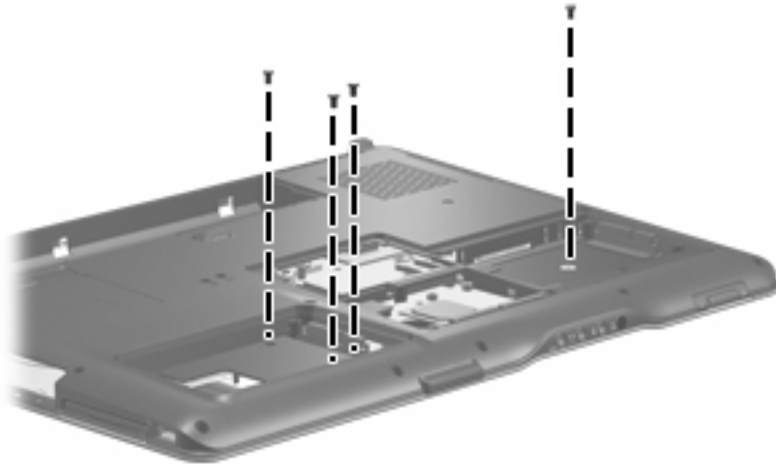

Where used: 4 screws that secure the top cover to the computer

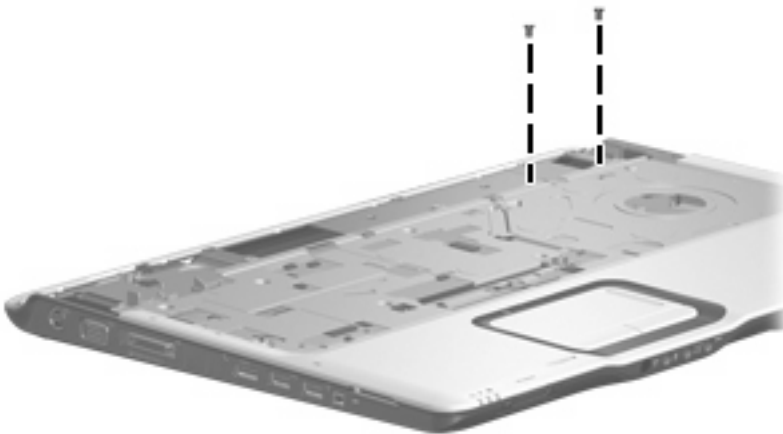

Where used: 2 screws that secure the top cover to the computer

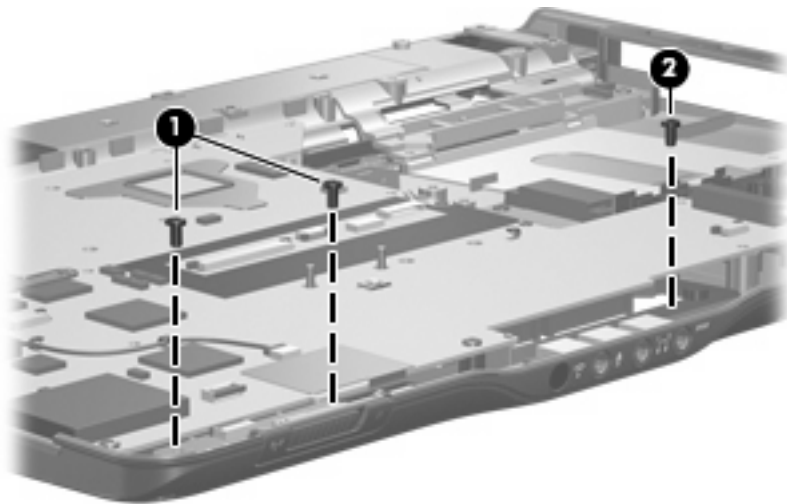

Where used:

- (1) Two screws that secure the wireless switch board to the computer
- (2) One screw that secures the audio board to the computer

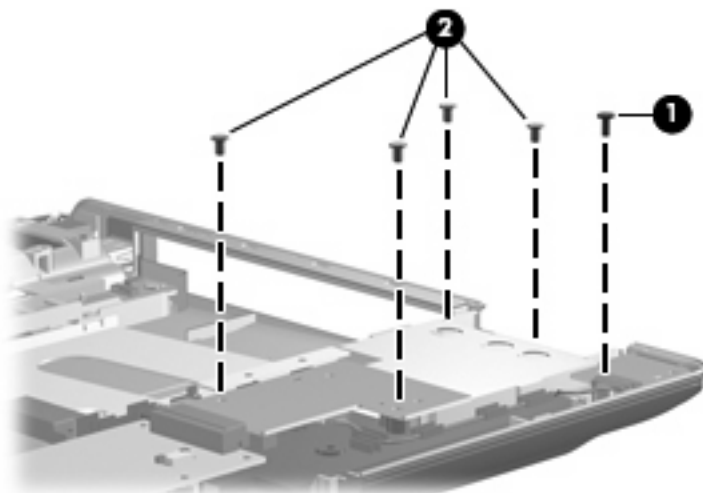

Where used:

- (1) One screw that secures the rear USB board to the base enclosure
- (2) Four screws that secure the ExpressCard assembly to the system board

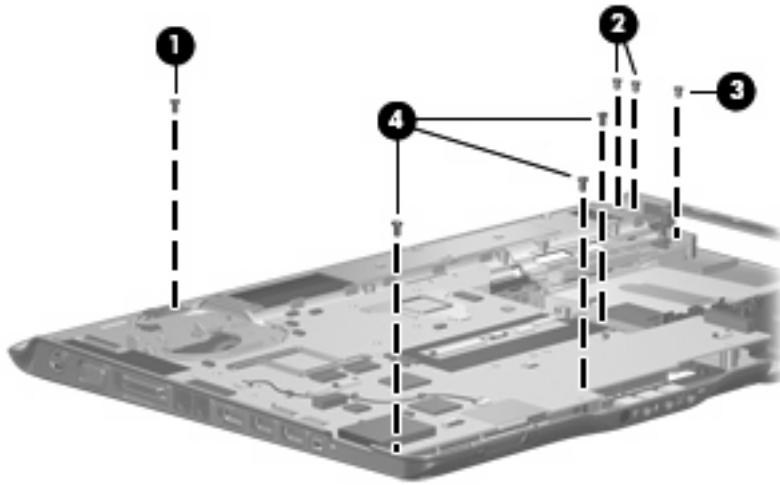

Where used:

- (1)** One screw that secures the display switch module to the fan/heat sink assembly
- (2)** Two screws that secure the power connector cable bracket to the base enclosure
- (3)** One screw that secures the rear USB board to the base enclosure
- (4)** 3 screws that secure the system board to the base enclosure

Phillips PM2.5×6.0 screw

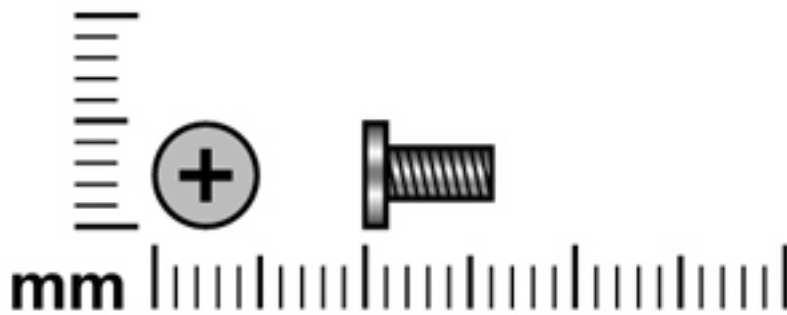

Color	Quantity	Length	Thread	Head width
Black	2	6.0 mm	2.5 mm	5.0 mm

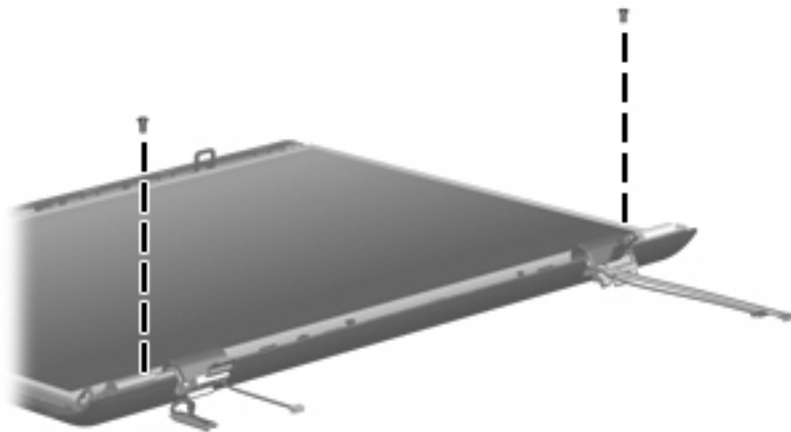

Where used: 2 screws that secure the display panel to the display assembly

Phillips PM2.0×4.0 screw

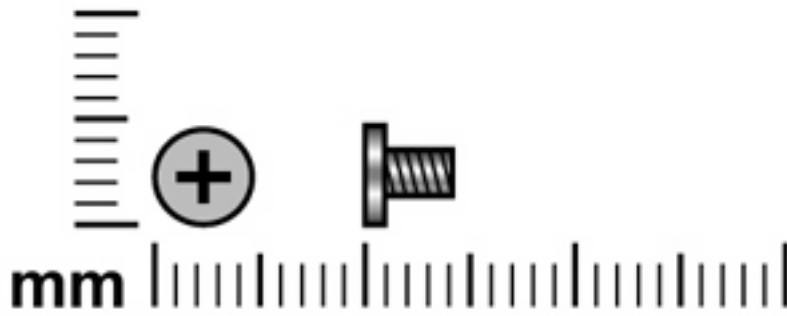

Color	Quantity	Length	Thread	Head width
Black	4	4.0 mm	2.0 mm	4.5 mm

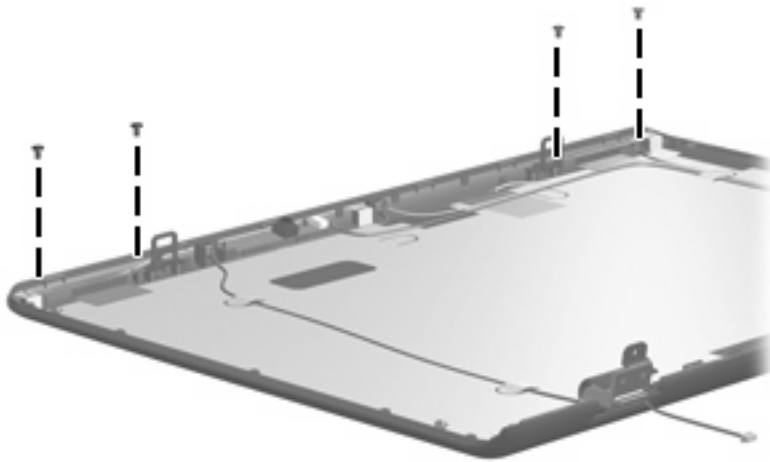

Where used: 4 screws that secure the wireless antenna transceivers to the display enclosure

Phillips 2.5×4.0 captive screw

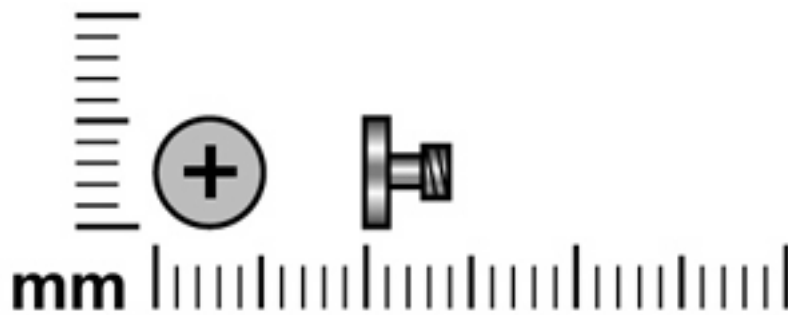

Color	Quantity	Length	Thread	Head width
Silver	2	4.0 mm	2.5 mm	5.0 mm

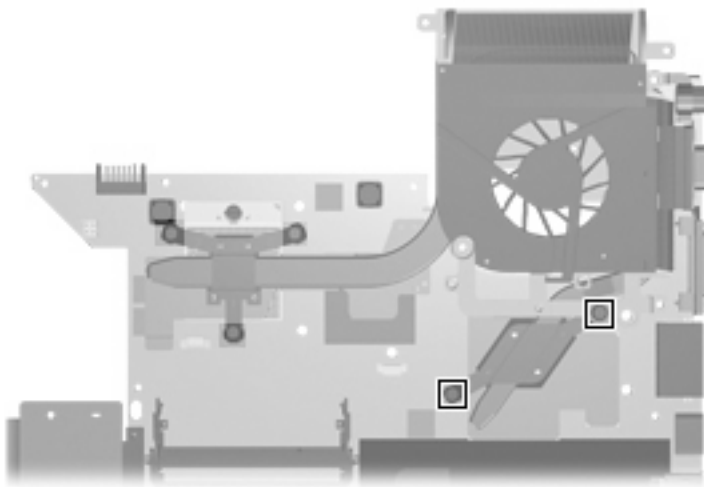

Where used: 2 captive screws that secure the heat sink to the system board

8 Backup and Recovery

Recovering system information

Tools provided by the operating system and Recovery Manager software are designed to help you with the following tasks for safeguarding your information and restoring it in case of a system failure:

- Back up your information regularly to protect your important system files.
- Make a set of recovery discs (Recovery Manager software feature). Recovery discs are used to start up (boot) your computer and restore the operating system and software programs to factory settings in case of system failure or instability.
- Create system restore points (operating system feature). System restore points allow you to reverse undesirable changes to your computer by restoring the computer to an earlier state.
- Recover a program or driver (Recovery Manager software feature). This feature helps you reinstall a program or driver without performing a full system recovery.
- Perform a full system recovery (Recovery Manager software feature). With Recovery Manager, you can recover your full factory image if you experience system failure or instability. Recovery Manager works from a dedicated recovery partition on the hard drive or from recovery discs you create.

Backing up your information

When to back up

- On a regularly scheduled basis.

 **NOTE:** Set reminders to back up your information periodically.

- Before the computer is repaired or restored.
- Before you add or modify hardware or software.

Back up suggestions

- Create system restore points using the Windows System Restore feature.
- Store personal files in the Documents folder and back up these folders periodically.
- Back up templates stored in their associated programs.
- Save customized settings in a window, toolbar, or menu bar by taking a screen shot of your settings.

The screen shot can be a time saver if you have to reset your preferences.

To copy the screen shot and paste it into a word processing document:

- a. Display the screen.
- b. Copy the screen:
 - To copy only the active screen, press **alt+fn+prt sc**.
 - To copy the entire screen, press **fn+prt sc**.
- c. Open a word-processing document, and then select **Edit > Paste**.

Using system restore points

When you back up your system, you are creating a system restore point. A system restore point allows you to save and name a snapshot of your hard drive at a specific point in time. You can then recover back to that point if you want to reverse subsequent changes made to your system.

 **NOTE:** Recovering to an earlier restore point does not affect data files saved or e-mails created since the last restore point.

You also can create additional restore points to provide increased protection for your system files and settings.

When to create restore points

- Before you add or extensively modify software or hardware.
- Periodically, whenever the system is performing optimally.

 **NOTE:** If you revert to a restore point and then change your mind, you can reverse the restoration.

Create a system restore point

1. Select **Start > Control Panel > System and Maintenance > System**.
2. In the left pane, click **System protection**.
3. Click the **System Protection** tab.
4. Under Automatic restore points, select the disk for which you want to create a restore point.
5. Click **Create**.

The System Protection window opens.
6. Follow the on-screen instructions.

Restore to a previous date and time

1. Select **Start > Control Panel > System and Maintenance > System**.
2. In the left pane, click **System protection**.
3. Click the **System Protection** tab.
4. Click the **System Restore** button, and then click **Next**.
The System Restore window opens.
5. Follow the on-screen instructions.

Creating recovery discs

Recovery Manager creates a set of recovery CDs or DVDs for the computer. Use recovery discs to restore the operating system and software programs to factory settings, in case of system failure or instability.

 **NOTE:** Handle these discs carefully and keep them in a safe place. The software allows the creation of only one set of recovery discs.

Note the following guidelines before creating recovery discs:

- You will need high quality CD-R, DVD-R, or DVD+R media (purchased separately).
-  **NOTE:** Formatted DVD±RW discs and DVD±RW double-layer discs are not compatible with the Recovery Manager software.
-
- The computer must be connected to AC power during this process.
 - Only one set of recovery discs can be created per computer.
 - Number each disc before inserting it into the computer optical drive.
 - If necessary, you can exit the program before you have finished creating the recovery discs. The next time you open Recovery Manager, you will be prompted to continue the disc creation process.

To create a set of recovery discs:

1. Select **Start > All Programs > Recovery Manager > Recovery Manager**.
Recover Manager opens.
2. Click **Advanced Options**.

 **NOTE:** If you are operating the computer on battery power, you will be prompted to connect to AC power before you can go to the next step.
3. Click **Recovery disc creation**, and then click **Next**.
4. Follow the on-screen instructions.

Reinstalling software programs and drivers

If a program or driver preinstalled at the factory is accidentally erased or is damaged, Recovery Manager allows you to reinstall it.

 **NOTE:** Software not provided with this computer must be reinstalled from the disc provided by the manufacturer or downloaded from the manufacturer's Web site.

NOTE: Before reinstalling the program, be sure it is fully uninstalled.

Recovery Manager replaces corrupted system files and reinstalls deleted system files within the program.

- In most cases, if the program you are reinstalling is still on your computer, the reinstallation process does not affect your personal settings.
- In all cases, if a program has been deleted from your computer, the reinstallation process reinstalls the program or utility to the factory image but cannot restore your personal settings.

Reinstalling preinstalled programs and drivers

1. Remove the program or driver:

 **NOTE:** In some cases, drivers are not listed in the Programs and Features list. If the driver is not listed, it does not need to be removed.

- a. Select **Start > Control Panel > Programs > Uninstall a program**.
 - b. Right-click the program or driver you want to remove, and then click **Uninstall**.
2. Reinstall the program or driver:
 - a. Select **Start > All Programs > Recovery Manager > Recovery Manager**.
 - b. Click **Advanced Options**.
 - c. Click either **Software program re-installation** or **Hardware driver re-installation**, and then click **Next**.
 - d. Follow the on-screen instructions.
 - e. Restart the computer if prompted.

Reinstalling programs from discs

1. Insert the disc into the optical drive.
2. When the installation wizard opens, follow the installation instructions on the screen.
3. Restart the computer if prompted.

Performing a recovery

Recovery Manager software allows you to repair or restore the system if you experience system failure or instability. Recovery Manager works from recovery discs that you create or from a dedicated recovery partition on the hard drive.

 **NOTE:** Windows has its own built-in repair features, such as System Restore and driver rollback capabilities. If you have not already tried these features, try them before using Recovery Manager.

NOTE: Recovery Manager only recovers software that was preinstalled at the factory. Software not provided with this computer must be reinstalled from the disc provided by the manufacturer or downloaded from the manufacturer's Web site.

Recovering from the recovery discs

To restore the system from the recovery discs:

1. Back up all personal files.
2. Insert the first recovery disc into the optical drive and restart the computer.
3. Follow the on-screen instructions.

Recovering from the partition on the hard drive

You can perform a recovery from the partition on the hard drive from either the Start button or **f11**.

To restore the system from the partition, follow these steps:

1. Access Recovery Manager in either of the following ways:
 - Select **Start > All Programs > Recovery Manager > Recovery Manager**.
 - Restart the computer and press **f11** while the "Press <F11> for recovery" message is displayed on the screen. Then select **Recovery Manager**.

Recovery Manager opens.

2. Click **Advanced Options**.
3. Click **System recovery**, and then click **Next**.
4. Follow the on-screen instructions.

Deleting the recovery partition on the hard drive

The Recovery Manager Advanced Options menu provides the option of deleting the recovery partition, which will increase space on the hard drive. Delete the recovery partition only if you have already created recovery discs.

△ **CAUTION:** After you create the recovery discs, you can increase space on the hard drive by deleting the recovery partition. However, doing this is not recommended. If you delete this partition, you will lose any information that is on the partition, including Recovery Manager software. Thereafter, you must use the recovery discs to access Recovery Manager software.

To delete the recovery partition:

1. If you have not already created recovery discs, create them now.
2. Select **Start > All Programs > Recovery Manager > Recovery Manager**.
Recovery Manager opens.
3. Click **Advanced Options**.
4. Click **Remove recovery partition**, and then click **Next**.
5. Follow the on-screen instructions.

Updating reinstalled software

After you perform a system recovery, connect to the Internet to update all reinstalled software.

To access update links for the operating system and other software provided on your computer:

- Select **Start > Help and Support**.

To update optional software, follow the instructions provided by the software manufacturer. Some programs include an update feature you can access from a Help button or menu within the program.

9 Connector pin assignments

Audio-out (headphone)

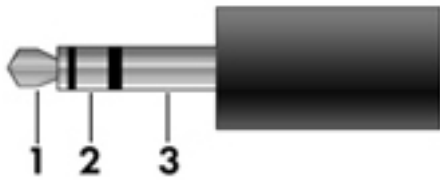

Pin	Signal
1	Audio out, left channel
2	Audio out, right channel
3	Ground

Audio-in (microphone)

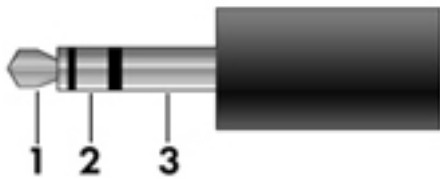

Pin	Signal
1	Audio signal in
2	Audio signal in
3	Ground

External monitor

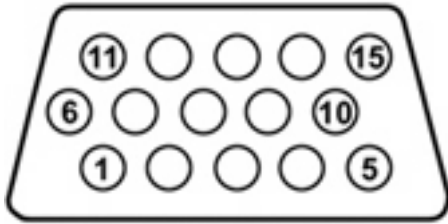

Pin	Signal
1	Red analog
2	Green analog
3	Blue analog
4	Not connected
5	Ground
6	Ground analog
7	Ground analog
8	Ground analog
9	+5 VDC
10	Ground
11	Monitor detect
12	DDC 2B data
13	Horizontal sync
14	Vertical sync
15	DDC 2B clock

RJ-11 (modem)

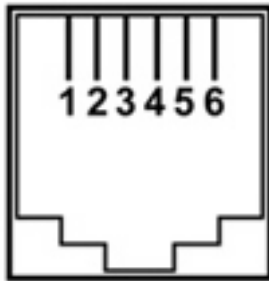

Pin	Signal
1	Unused
2	Tip
3	Ring
4	Unused
5	Unused
6	Unused

RJ-45 (network)

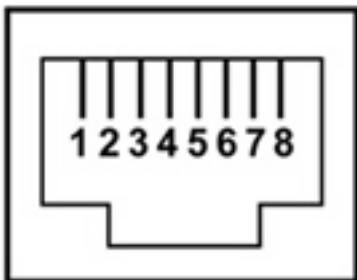

Pin	Signal
1	Transmit +
2	Transmit -
3	Receive +
4	Unused
5	Unused
6	Receive -
7	Unused
8	Unused

S-Video-out



Pin	Signal
1	S-VHS color (C) signal
2	Composite video signal
3	S-VHS intensity (Y) signal
4	S-VHS color ground
5	TV-CD
6	S-VHS intensity ground
7	Composite video ground

Universal Serial Bus

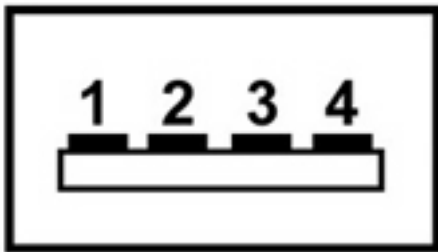

Pin	Signal
1	+5 VDC
2	Data -
3	Data +
4	Ground

10 Power cord set requirements

The wide range input feature of the computer permits it to operate from any line voltage from 100 to 120 volts AC or from 220 to 240 volts AC.

The 3-conductor power cord set included with the computer meets the requirements for use in the country or region where the equipment is purchased.

Power cord sets for use in other countries or regions must meet the requirements of the country or region where the computer is used.

Requirements for all countries or regions

The requirements listed below are applicable to all countries or regions:

- The length of the power cord set must be at least 1.5 m (5.0 ft) and no more than 2.0 m (6.5 ft).
- All power cord sets must be approved by an acceptable accredited agency responsible for evaluation in the country or region where the power cord set will be used.
- The power cord sets must have a minimum current capacity of 10 amps and a nominal voltage rating of 125 or 250 V AC, as required by each country or region's power system.
- The appliance coupler must meet the mechanical configuration of an EN 60 320/IEC 320 Standard Sheet C13 connector for mating with the appliance inlet on the back of the computer.

Requirements for specific countries or regions

Country or region	Accredited agency	Applicable note number
Australia	EANSW	1
Austria	OVE	1
Belgium	CEBC	1
Canada	CSA	2
Denmark	DEMKO	1
Finland	FIMKO	1
France	UTE	1
Germany	VDE	1
Italy	IMQ	1
Japan	METI	3
Korea	EK	4
The Netherlands	KEMA	1
Norway	NEMKO	1
The People's Republic of China	CCC	5
Sweden	SEMKO	1
Switzerland	SEV	1
Taiwan	BSMI	4
The United Kingdom	BSI	1
The United States	UL	2

1. The flexible cord must be Type HO5VV-F, 3-conductor, 1.0-mm² conductor size. Power cord set fittings (appliance coupler and wall plug) must bear the certification mark of the agency responsible for evaluation in the country or region where it will be used.
2. The flexible cord must be Type SPT-3 or equivalent, No. 18 AWG, 3-conductor. The wall plug must be a two-pole grounding type with a NEMA 5-15P (15 A, 125 V) or NEMA 6-15P (15 A, 250 V) configuration.
3. The appliance coupler, flexible cord, and wall plug must bear a "T" mark and registration number in accordance with the Japanese Dentori Law. The flexible cord must be Type VCT or VCTF, 3-conductor, 1.00-mm² conductor size. The wall plug must be a two-pole grounding type with a Japanese Industrial Standard C8303 (7 A, 125 V) configuration.
4. The flexible cord must be Type RVV, 3-conductor, 0.75-mm² conductor size. Power cord set fittings (appliance coupler and wall plug) must bear the certification mark of the agency responsible for evaluation in the country or region where it will be used.
5. The flexible cord must be Type VCTF, 3-conductor, 0.75-mm² conductor size. Power cord set fittings (appliance coupler and wall plug) must bear the certification mark of the agency responsible for evaluation in the country or region where it will be used.

11 Recycling

Battery

When a battery has reached the end of its useful life, do not dispose of the battery in general household waste. Follow the local laws and regulations in your area for computer battery disposal.

Display

- ⚠ **WARNING!** The backlight contains mercury. Caution must be exercised when removing and handling the backlight to avoid damaging this component and causing exposure to the mercury.
- ⚠ **CAUTION:** The procedures in this appendix can result in damage to display components. The only components intended for recycling purposes are the liquid crystal display (LCD) panel and the backlight. Careful handling must be exercised when removing these components.
- 📄 **NOTE: Materials Disposal.** This HP product contains mercury in the backlight in the display assembly that might require special handling at end-of-life. Disposal of mercury may be regulated because of environmental considerations. For disposal or recycling information, contact your local authorities, or see the Electronic Industries Alliance (EIA) Web site at <http://www.eiae.org>.

This section provides disassembly instructions for the display assembly. The display assembly must be disassembled to gain access to the backlight **(1)** and the liquid crystal display (LCD) panel **(2)**.



- 📄 **NOTE:** The procedures provided in this appendix are general disassembly instructions. Specific details, such as screw sizes, quantities, and locations, and component shapes and sizes, can vary from one computer model to another.

Perform the following steps to disassemble the display assembly:

1. Remove all screw covers **(1)** and screws **(2)** that secure the display bezel to the display assembly.

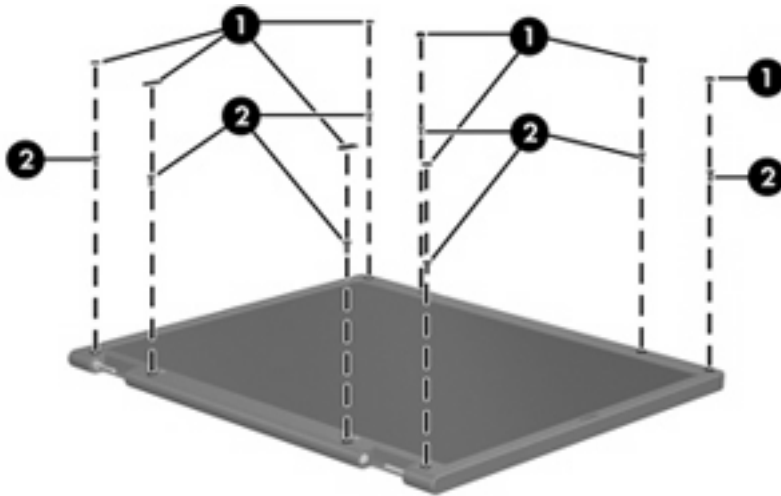

2. Lift up and out on the left and right inside edges **(1)** and the top and bottom inside edges **(2)** of the display bezel until the bezel disengages from the display assembly.
3. Remove the display bezel **(3)**.

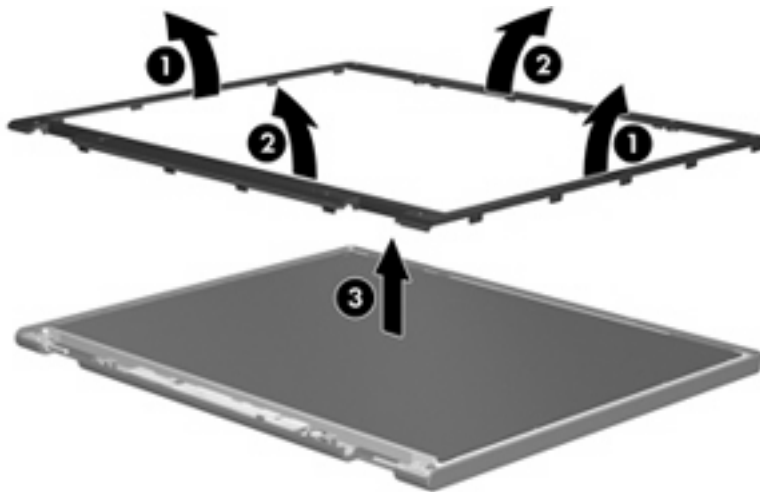

4. Disconnect all display panel cables **(1)** from the display inverter and remove the inverter **(2)**.

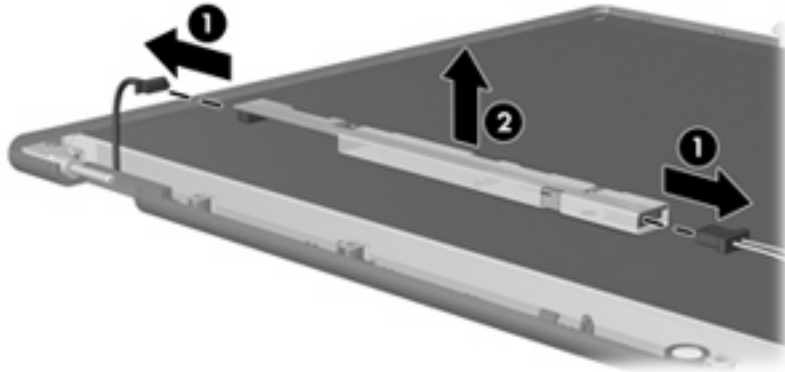

5. Remove all screws **(1)** that secure the display panel assembly to the display enclosure.
6. Remove the display panel assembly **(2)** from the display enclosure.

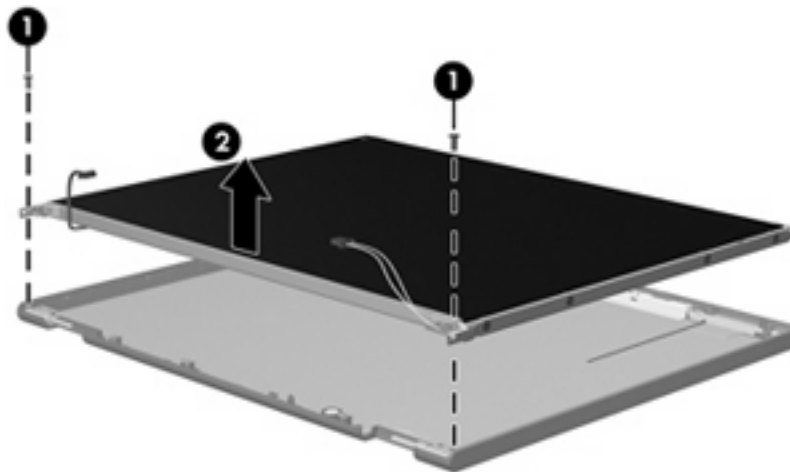

7. Turn the display panel assembly upside down.
8. Remove all screws that secure the display panel frame to the display panel.

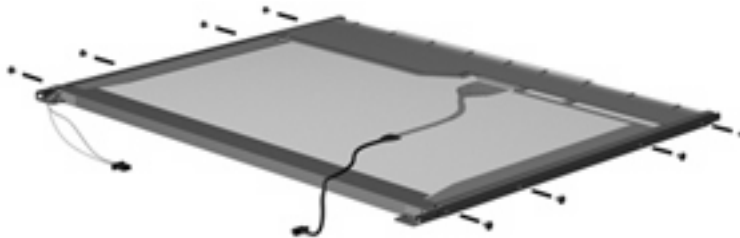

9. Use a sharp-edged tool to cut the tape **(1)** that secures the sides of the display panel to the display panel frame.

10. Remove the display panel frame **(2)** from the display panel.

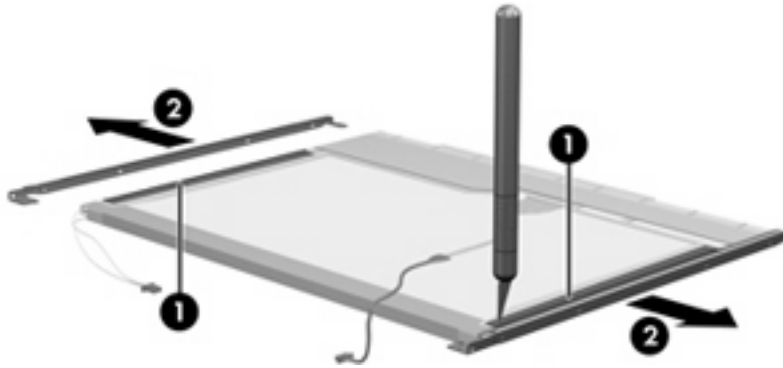

11. Remove the screws **(1)** that secure the backlight cover to the display panel.
12. Lift the top edge of the backlight cover **(2)** and swing it outward.

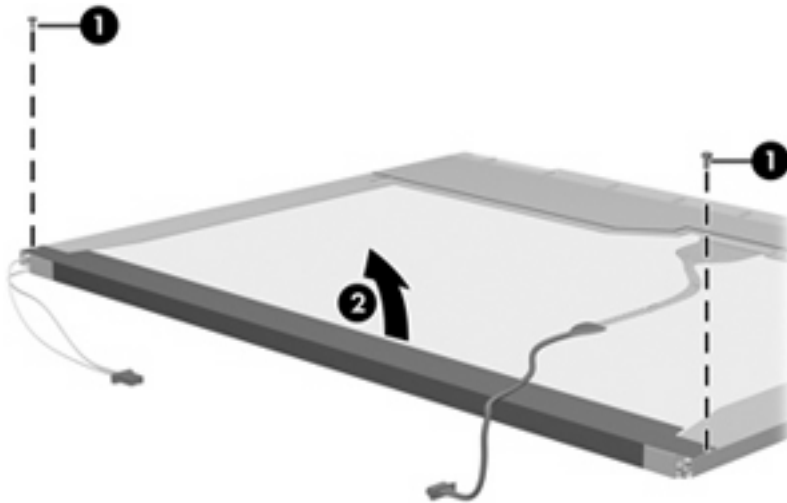

13. Remove the backlight cover.
14. Turn the display panel right-side up.

15. Remove the backlight cables (1) from the clip (2) in the display panel.

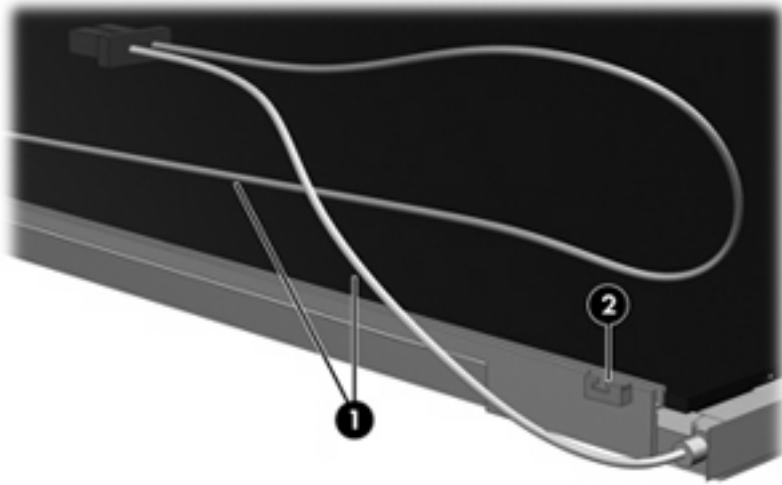

16. Turn the display panel upside down.
17. Remove the backlight frame from the display panel.

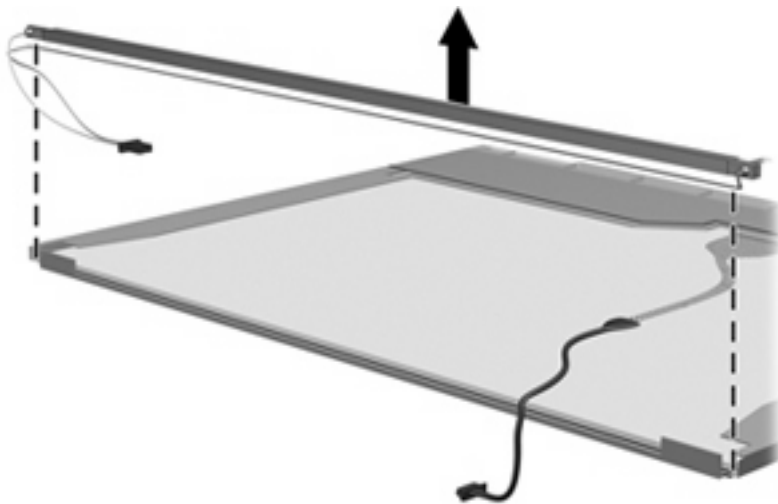

⚠ WARNING! The backlight contains mercury. Exercise caution when removing and handling the backlight to avoid damaging this component and causing exposure to the mercury.

18. Remove the backlight from the backlight frame.

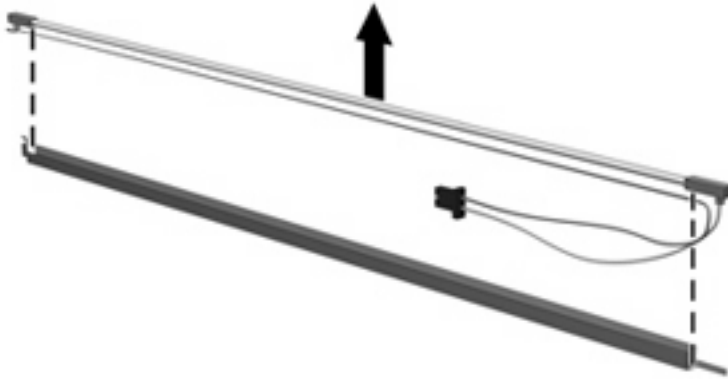

19. Disconnect the display cable (1) from the LCD panel.
20. Remove the screws (2) that secure the LCD panel to the display rear panel.
21. Release the LCD panel (3) from the display rear panel.
22. Release the tape (4) that secures the LCD panel to the display rear panel.

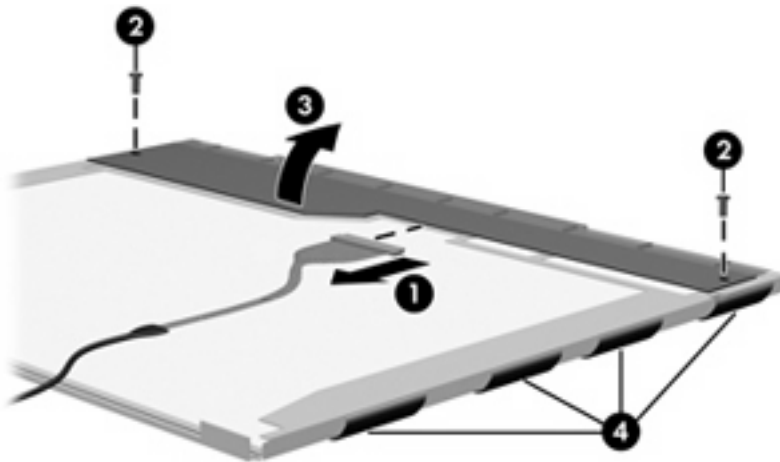

23. Remove the LCD panel.

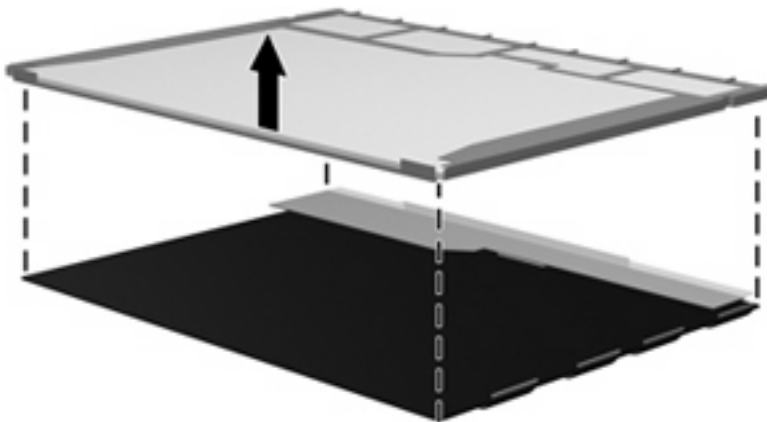

24. Recycle the LCD panel and backlight.

Index

Symbols/Numerics

1394 port, location 12

A

AC adapter, spare part
number 26, 27

administrator password 100

advanced Setup Utility
features 99

antenna

removal 66

spare part numbers 21, 31,
66

applications key, Windows 8

arrow keys 8

audio board

removal 89

spare part number 18, 31,
89

audio, product description 2

audio-in jack

location 10

pin assignments 137

audio-out jack

location 10

pin assignments 137

audio-out S/PDIF jack,

location 10

B

backpack, spare part
number 26, 27

backup 131

base enclosure, spare part
numbers 18, 31

battery

removal 40

spare part numbers 18, 28,
30, 40

battery bay 13

battery light 10

battery release latch 13

bezel

removal 64

spare part numbers 64

Bluetooth module

removal 75

spare part number 18, 28,
75

Bluetooth module cable,

illustrated 24

boot options 100

boot order 100

bottom components 13

button sound 100

buttons

DVD 7

media 7

next/fast forward 7

play/pause 7

power 6

previous/rewind 7

QuickPlay 7

stop 7

volume mute 6

C

Cable Kit

contents 24

spare part number 20, 24,
30

cables, service considerations 34

camera 5

camera cable

removal 67

spare part number 67

camera module

illustrated 21

removal 41, 42

spare part number 21, 30,
41

camera, product description 2

caps lock key 8

caps lock light 6

carrying case, spare part
number 26

changing the Setup Utility
language 97

chipset, product description 1

closing the Setup Utility 99

CMOS clearing 38

components

bottom 13

display 5

front 10

keyboard 8

left-side 11

QuickPlay buttons 7

right-side 11

top 5

TouchPad 9

composite video cable, spare part
number 26, 28

computer feet

locations 47

spare part number 18, 31,
47

computer specifications 101

connectors, service

considerations 34

D

Diagnostics menu 100

Digital Media Slot 12

Digital Media Slot light 12

diskette drive

precautions 34

product description 2

- display assembly
 - removal 62
 - spare part numbers 16, 30, 62
- display bezel
 - illustrated 21
 - release 41, 43
 - removal 64
 - spare part numbers 21, 30, 64
- Display Cable Kit, spare part number 21, 28
- display components
 - illustrated 21
 - recycling 143
- display enclosure
 - illustrated 21
 - spare part number 22, 30
- display hinge
 - removal 65
 - spare part number 66
- Display Hinge Kit, spare part number 21, 28
- display hinges
 - spare part number 21
- display inverter
 - illustrated 21
 - removal 43, 44
 - spare part number 21, 28, 43
- display lid latch 10
- display panel
 - illustrated 21
 - product description 1
 - removal 65
 - spare part numbers 21, 30, 65
- Display Screw Kit, spare part number 22, 28
- display specifications 102, 103
- display switch module
 - removal 82
 - spare part number 17, 31, 82
- docking support, product description 3
- drive light 10
- drivers, reinstalling 134

- drives
 - boot order 100
 - preventing damage 34
- DVB-T antenna adapter, spare part number 26, 28
- DVB-T tuner, spare part number 26, 28
- DVD button 7
- DVD±RW and CD-RW Combo Drive
 - precautions 34
 - removal 52
 - spare part numbers 20, 25, 30, 52
 - specifications 105

E

- electrostatic discharge 35
- enhanced SATA support 100
- Ethernet, product description 2
- expansion port 3 11
- ExpressCard assembly
 - removal 78
 - spare part number 18, 28, 78
- ExpressCard Kit, spare part number 26, 30
- ExpressCard slot 11
- ExpressCard slot bezel
 - illustrated 23
 - removal 79
- external media cards, product description 3
- external monitor port
 - location 11
 - pin assignments 138

F

- fan/heat sink assembly
 - removal 91
 - spare part number 18, 31, 91
- feet
 - locations 47
 - spare part number 18, 31, 47
- fingerprint reader 97
- fingerprint reader board cable, illustrated 24
- fingerprint reader board, spare part number 18, 30, 68

- fn key 8
- front components 10
- front USB board
 - removal 77
 - spare part number 18, 31, 77
- front USB board cable, illustrated 24
- function keys 8

G

- graphics, product description 1
- grounding equipment and methods 37

H

- hard drive
 - precautions 34
 - product description 1
 - removal 45
 - spare part numbers 19, 25, 28, 29, 30, 45
 - specifications 104
- hard drive bays 13
- hard drive bracket rails, spare part number 19, 31
- hard drive connector, spare part number 19, 31
- hard drive cover
 - illustrated 23
 - removal 45
- hard drive screws, spare part number 19, 31
- hard drive self test 100
- Hardware Kit, spare part number 19, 31
- HDMI port, location 12
- headphone jack
 - location 10
 - pin assignments 137
- headset, spare part number 26, 27
- hinge
 - removal 65
 - spare part number 28, 66
- hinge cover
 - removal 66
 - spare part number 21, 28, 66

- hinges
 - spare part number 21
- I**
- I/O address specifications 108
- infrared emitter, spare part number 26, 28
- infrared lens 10
- interrupt specifications 107
- inverter
 - illustrated 21
 - removal 43, 44
 - spare part number 21, 28, 43
- J**
- jacks
 - audio-in 10
 - audio-out 10
 - audio-out S/PDIF 10
 - headphone 10
 - microphone 10
 - modem 11
 - network 11
 - RJ-11 11
 - RJ-45 11
 - S-Video-out jack 11
- K**
- keyboard
 - components 8
 - product description 3
 - removal 56
 - spare part numbers 17, 29, 56
- keypad keys 8
- keys
 - arrow 8
 - caps lock key 8
 - embedded numeric keypad 8
 - fn 8
 - function 8
 - num lock 8
 - Windows applications 8
 - Windows logo 8
- L**
- language support 97, 100
- left-side components 11
- lights
 - battery 10
- caps lock 6
- drive 10
- num lock 5
- power 10
- wireless 10
- M**
- main menu 99
- mass storage devices, spare part numbers 25
- media button 7
- memory map specifications 110
- memory module
 - product description 1
 - removal 47
 - spare part numbers 20, 30, 47
- memory/WLAN module compartment 13
- memory/WLAN module compartment cover
 - illustrated 23
 - removal 48
- microphone
 - location 5
 - removal 66
 - spare part number 21, 28, 67
- microphone jack
 - location 10
 - pin assignments 137
- model name 1
- modem jack
 - location 11
 - pin assignments 139
- modem, product description 2
- monitor port
 - location 11
 - pin assignments 138
- mouse, spare part numbers 26, 28
- N**
- navigating in the Setup Utility 98
- network jack
 - location 11
 - pin assignments 139
- next/fast forward button 7
- num lock key 8
- num lock light 5
- O**
- operating system, product description 3
- optical drive
 - location 11, 13
 - precautions 34
 - product description 2
 - removal 52
 - spare part numbers 20, 25, 52
 - specifications 105
- optical drive connector board
 - removal 87
 - spare part numbers 18, 28, 31, 87
- P**
- packing guidelines 36
- password clearing 38
- passwords 100
- pin assignments
 - audio-in 137
 - audio-out 137
 - external monitor 138
 - headphone 137
 - microphone 137
 - modem 139
 - monitor 138
 - network 139
 - RJ-11 139
 - RJ-45 139
 - S-Video-out 140
 - Universal Serial Bus (USB) 140
- plastic parts 33
- Plastics Kit
 - contents 23
 - spare part number 18, 23, 30
- play/pause button 7
- pointing device
 - components 9
 - product description 3
- ports
 - 1394 12
 - external monitor port 11
 - HDMI 12
 - monitor port 11
 - product description 3
 - Universal Serial Bus (USB) 11, 12

- power button 6
- power button board
 - removal 60
 - spare part number 17, 28, 60
- power connector 11
- power connector bracket
 - removal 84
 - spare part number 18, 28, 84
- power cord set requirements 141
- power cord, spare part numbers 26, 27
- power light 10
- power requirements, product description 3
- power-on password 100
- previous/rewind button 7
- processor
 - product description 1
 - removal 94
 - spare part numbers 18, 30, 94
- product description
 - audio 2
 - camera 2
 - chipset 1
 - diskette drive 2
 - display panel 1
 - docking support 3
 - Ethernet 2
 - external media cards 3
 - graphics 1
 - hard drives 1
 - keyboard 3
 - memory module 1
 - modem 2
 - operating system 3
 - optical drives 2
 - pointing device 3
 - ports 3
 - power requirements 3
 - processors 1
 - product name 1
 - security 3
 - serviceability 3
 - wireless 2
- product name 1

Q

- QuickPlay buttons 7

R

- rear USB board
 - removal 83
 - spare part number 18, 31, 83
- rear USB board cable, illustrated 24
- recovery discs 133
- recovery partition, deleting 136
- recovery, system 135
- remote control, spare part numbers 26, 28, 29
- removal/replacement
 - preliminaries 33
 - procedures 39
- restore points 132
- RF input adapter cable, spare part number 26, 28
- right-side components 11
- RJ-11 jack
 - location 11
 - pin assignments 139
- RJ-45 jack
 - location 11
 - pin assignments 139
- RTC battery
 - removal 49
 - spare part number 19, 30, 49
- Rubber Feet Kit, spare part number 18, 31, 47

S

- S-Video-out jack
 - location 11
 - pin assignments 140
- Screw Kit
 - contents 111
 - spare part number 27, 28
- screw listing 111
- secondary hard drive self test 100
- security cable slot 11
- Security menu 100
- security, product description 3
- selecting in the Setup Utility 98
- serial number 15, 39
- service considerations 33

- serviceability, product description 3
- Setup Utility
 - changing the language 97
 - Diagnostics menu 100
 - displaying system information 98
 - Main menu 99
 - navigating 98
 - overview 97
 - Security menu 100
 - selecting 98
 - starting 97
 - System Configuration menu 100
 - using advanced features 99
- software
 - reinstalling 134
 - updating 136
- speaker assembly
 - removal 59
 - spare part number 17, 28, 59
- speakers 5
- specifications
 - computer 101
 - display 102, 103
 - DVD±RW and CD-RW Combo Drive 105
 - hard drive 104
 - I/O addresses 108
 - interrupts 107
 - memory map 110
 - optical drive 105
 - system DMA 106
- static-shielding materials 37
- stop button 7
- switch cover
 - removal 54
 - spare part number 17, 30, 54
- system board
 - removal 85
 - spare part number 18, 30, 85
- System Configuration menu 100
- system DMA 106
- system information 98, 99
- system memory map 110

T

thermal material,
 replacement 92, 93
tools required 33
top components 5
top cover
 removal 68
 spare part numbers 18, 30,
 68
top cover trim
 removal 80
 spare part number 18, 28,
 80
TouchPad components
 left button 9
 light 9
 on/off button 9
 right button 9
 scroll zone 9
 TouchPad 9
transporting guidelines 36
TV tuner antenna, spare part
 number 26, 29
TV tuner, spare part number 26,
 28

U

Universal Serial Bus (USB) port
 locations 11, 12
 pin assignments 140
unknown password 38
USB digital drive, spare part
 number 26

V

vents 13
video memory 100
volume mute button 6
volume scroll zone 6

W

Windows applications key 8
Windows logo key 8
wireless antenna
 removal 66
 spare part numbers 66
wireless light 10
wireless switch 10

wireless switch board
 removal 73
 spare part number 18, 28,
 73
wireless, product description 2
WLAN module
 removal 50
 spare part numbers 19, 27,
 29, 50
workstation guidelines 36

