

HP Photosmart C6200 All-in-One series

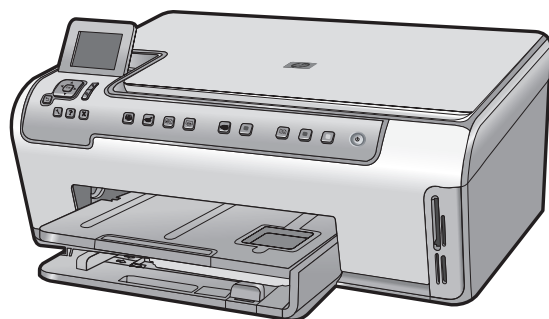

Basics Guide



Hewlett-Packard Company notices

The information contained in this document is subject to change without notice.

All rights reserved. Reproduction, adaptation, or translation of this material is prohibited without prior written permission of Hewlett-Packard, except as allowed under copyright laws. The only warranties for HP products and services are set forth in the express warranty statements accompanying such products and services. Nothing herein should be construed as constituting an additional warranty. HP shall not be liable for technical or editorial errors or omissions contained herein.

© 2007 Hewlett-Packard Development Company, L.P.

Windows, Windows 2000, and Windows XP are U.S. registered trademarks of Microsoft Corporation.

Windows Vista is either a registered trademark or trademark of Microsoft Corporation in the United States and/or other countries.

Intel and Pentium are trademarks or registered trademarks of Intel Corporation or its subsidiaries in the United States and other countries.

Contents

1 HP All-in-One overview	
The HP All-in-One at a glance.....	2
Control panel features.....	3
Find more information.....	4
2 Network setup	
Wired network setup.....	6
Install the software for a network connection.....	8
Connect to additional computers on a network.....	9
Change the HP All-in-One from a USB connection to a network connection.....	9
Manage your network settings.....	9
3 Use the HP All-in-One features	
Load originals and load paper.....	12
Avoid paper jams.....	15
View and select photos.....	15
Scan an image.....	16
Make a copy.....	17
Replace the ink cartridges.....	17
Clean the HP All-in-One.....	20
4 Troubleshooting and support	
Uninstall and reinstall the software.....	22
Hardware setup troubleshooting.....	22
Network troubleshooting.....	25
Clear paper jams.....	26
Information on ink cartridges and the print head.....	27
Support process.....	28
5 Technical information	
System requirements.....	29
Product specifications.....	29
Ink cartridge yield.....	29
Regulatory notices.....	30
Warranty.....	31

1 HP All-in-One overview

Use the HP All-in-One to quickly and easily accomplish tasks such as making a copy, scanning documents, or printing photos. You can access many HP All-in-One functions directly from the control panel, without turning on your computer.

 **NOTE:** This guide introduces basic operations and troubleshooting, as well as provides information for contacting HP support and ordering supplies.

The onscreen Help details the full range of features and functions, including use of the HP Photosmart software that came with the HP All-in-One.

The HP All-in-One at a glance

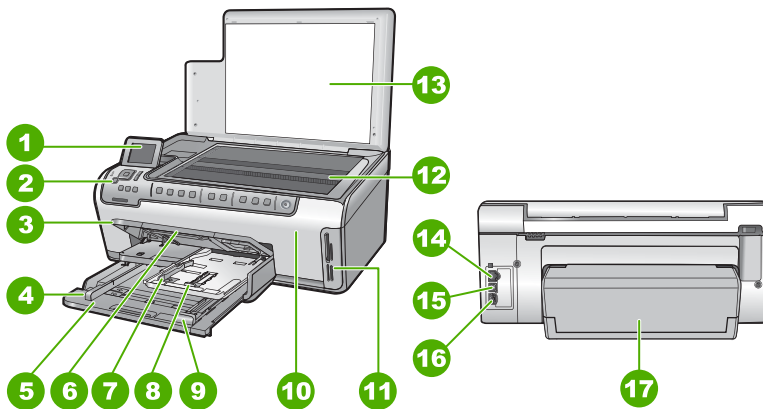

Label	Description
1	Color graphics display (also referred to as the display)
2	Control panel
3	Output tray (currently shown in the up position)
4	Paper-width guide for the main input tray
5	Main input tray (also referred to as the input tray)
6	Paper tray extender (also referred to as the tray extender)
7	Paper-width and paper-length guides for the photo tray
8	Photo tray
9	Paper-length guide for the main input tray
10	Ink cartridge door

(continued)

Label	Description
11	Memory card slots
12	Glass
13	Lid backing
14	Ethernet port
15	USB port
16	Power connection*
17	Two-sided printing accessory







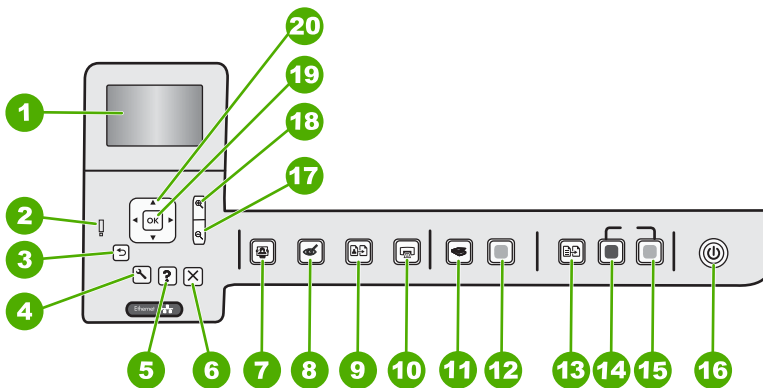







* Use only with the power adapter supplied by HP.

Control panel features

The following diagram and related table provide a quick reference to the HP All-in-One control panel features.



Label	Icon	Name and Description
1		Color graphics display (also referred to as the display): Displays menus, photos, and messages. The display can be pulled up and angled for better viewing.
2	!	Attention light: Indicates a problem occurred. See the display for more information.
3	↶	Back: Returns to the previous screen on the display.
4	🔧	Setup: Opens the Setup menu where you can generate reports, change device settings, and perform maintenance functions.
5	?	Help: Opens the Help Menu menu on the display where you can select a topic to learn more about it. From the idle state, pressing Help lists a menu of items for which help is available. Depending on the topic you select, the topic will appear on your display or on your computer screen. When viewing screens other than Idle, the Help button provides context sensitive help.

Label	Icon	Name and Description
6		Cancel: Stops the current operation.
7		Photo Menu: Launches the Photosmart Express menu for printing, saving, editing, and sharing photos.
8		Red Eye Removal: Turns the Red Eye Removal feature on or off. By default, this feature is turned off. When the feature is turned on, the HP All-in-One automatically corrects red eye coloring in the photo currently shown on the display.
9		Photo Reprints: Enables you to make a copy of an original photo placed on the glass.
10		Print Photos: Depending on whether you access your photos from the View , Print , or Create menu, the Print Photos button will display the Print Preview screen or it will print any selected photo(s). If no photos are selected, a prompt appears asking if you want to print all the photos on your card.
11		Scan Menu: Opens the Scan Menu where you can select a destination for your scan.
12		Start Scan: Starts a scan.
13		Copy Menu: Opens the Copy Menu where you can select copy options, such as number of copies, paper size, and paper type.
14		Start Copy Black: Starts a black-and-white copy.
15		Start Copy Color: Starts a color copy.
16		On: Turns the HP All-in-One on or off. When the HP All-in-One is off, a minimal amount of power is still supplied to the device. You can further reduce power supply by holding down the On button for 3 seconds. This will put the HP All-in-One in Standby/Off state. To completely remove power, turn the HP All-in-One off, and then unplug the power cord.
17		Zoom out - (magnifying glass icon): Zooms out to show more of a photo. If you press this button when a photo is shown on the display at 100%, the Fit to Page feature is applied to the photo automatically.
18		Zoom in + (magnifying glass icon): Zooms in to enlarge the image on the display. You can also use this button together with the arrows on the directional pad to adjust the crop box for printing.
19	OK	OK: Selects a menu setting, value, or photo on the display.
20		Directional pad: Allows you to navigate through photos and menu options by pressing the up, down, left, or right arrow buttons. If you are zooming in on a photo, you can also use the arrow buttons to pan around the photo and select a different area to print.

Find more information

A variety of resources, both printed and onscreen, provide information about setting up and using the HP All-in-One.

- **Setup Guide**
The Setup Guide provides instructions for setting up the HP All-in-One and installing software. Make sure you follow the steps in the Setup Guide in order.
If you have problems during setup, see Troubleshooting in the last section of the Setup Guide, or see [“Troubleshooting and support” on page 22](#) in this guide.
- **Onscreen Help**
The onscreen Help provides detailed instructions on features of the HP All-in-One that are not described in this Basics Guide, including features that are only available using the software you installed with the HP All-in-One.
- www.hp.com/support
If you have Internet access, you can get help and support from the HP Web site. This Web site offers technical support, drivers, supplies, and ordering information.

2 Network setup

This section describes how to connect the HP All-in-One to a network and how to view and manage network settings.

If you want to:	See this section:
Connect to a wired (Ethernet) network.	“Wired network setup” on page 6
Install the HP All-in-One software for use in a networked environment.	“Install the software for a network connection” on page 8
Add connections to more computers on the network.	“Connect to additional computers on a network” on page 9
Change the HP All-in-One from a USB connection to a network connection.	“Change the HP All-in-One from a USB connection to a network connection” on page 9
<p>NOTE: Use the instructions in this section if you first installed the HP All-in-One with a USB connection, and you now want to change to an Ethernet network connection.</p>	
View or change the network settings.	“Manage your network settings” on page 9
Find troubleshooting information.	“Network troubleshooting” on page 25

Wired network setup

This section describes how to connect the HP All-in-One to a router, switch, or hub using an Ethernet cable and how to install the HP All-in-One software for a network connection. This is known as a wired or Ethernet network.

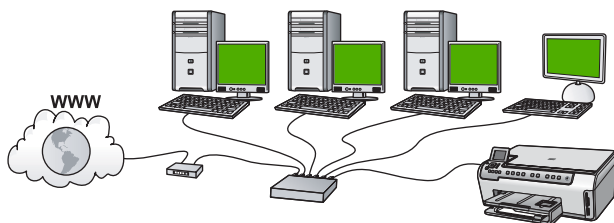

To set up the HP All-in-One on a wired network, you need to do the following:	See this section:
First, collect all of the required materials.	“What you need for a wired network” on page 7
Next, connect to a wired network.	“Connect the HP All-in-One to the network” on page 7
Finally, install the software.	“Install the software for a network connection” on page 8

What you need for a wired network

Before you connect the HP All-in-One to a network, make sure you have all of the required materials.

- ❑ A functional Ethernet network that includes a router, switch, or hub with an Ethernet port.
- ❑ CAT-5 Ethernet cable.

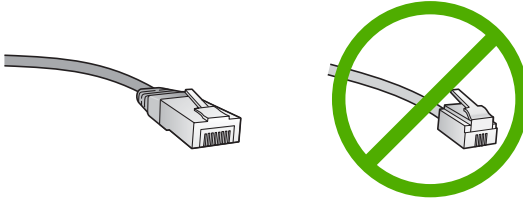

Although standard Ethernet cables look similar to standard telephone cables, they are not interchangeable. There is a different number of wires in each one, and each has a different connector. An Ethernet cable connector (also called an RJ-45 connector) is wider and thicker and always has 8 contacts on the end. A phone connector has between 2 and 6 contacts.

- ❑ A desktop computer or laptop with an Ethernet connection.

 **NOTE:** The HP All-in-One supports both 10 Mbps and 100 Mbps Ethernet networks. If you are purchasing, or have purchased, a network interface card (NIC), make sure it can operate at either speed.

Connect the HP All-in-One to the network

To connect the HP All-in-One to the network, use the Ethernet port on the back of the device.

To connect the HP All-in-One to the network

1. Remove the yellow plug from the back of the HP All-in-One.

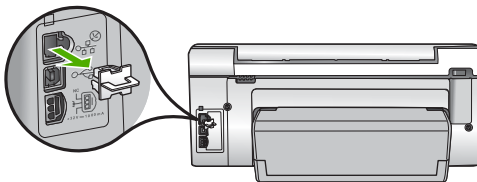

2. Connect the Ethernet cable to the Ethernet port on the back of the HP All-in-One.

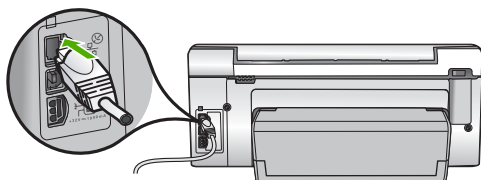

3. Connect the other end of the Ethernet cable to an available port on your Ethernet router, switch, or wireless router.

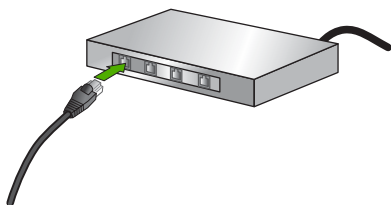

4. Once you have connected the HP All-in-One to the network, install the software as described in [“Install the software for a network connection”](#) on page 8.

Install the software for a network connection

Use this section to install the HP All-in-One software on a computer connected to a network. Before you install the software, make sure you have connected the HP All-in-One to a network.

-  **NOTE:** If your computer is configured to connect to a series of network drives, make sure that your computer is currently connected to these drives before installing the software. Otherwise, HP All-in-One installation software might try to use one of the reserved drive letters, and you will not be able to access that network drive on your computer.

NOTE: Installation time can range from 20 to 45 minutes depending on your operating system, the amount of available space, and the processor speed of your computer.

To install the Windows HP All-in-One software

1. Quit all applications running on your computer, including any virus detection software.
2. Insert the Windows CD that came with the HP All-in-One into the CD-ROM drive on your computer and follow the onscreen instructions.
3. If a dialog box about firewalls appears, follow the instructions. If you see firewall pop-up messages, you must always accept or allow the pop-up messages.
4. On the **Connection Type** screen, select **Through the network**, and then click **Next**.
The **Searching** screen appears as the Setup program searches for the HP All-in-One on the network.

5. On the **Printer Found** screen, verify that the printer description is correct. If more than one printer is found on the network, the **Printers Found** screen appears. Select the HP All-in-One you want to connect.
6. Follow the prompts to install the software. When you have finished installing the software, the HP All-in-One is ready for use.
7. If you disabled any virus detection software on your computer, make sure to enable it again.
8. To test your network connection, go to your computer and print a self-test report to the HP All-in-One.

Connect to additional computers on a network

You can connect the HP All-in-One to more than one computer on a small network of computers. If the HP All-in-One is already connected to a computer on a network, for each additional computer you must install the HP All-in-One software. Once you have set up the HP All-in-One on the network you will not need to configure it again when you add additional computers.

Change the HP All-in-One from a USB connection to a network connection

If you first install the HP All-in-One with a USB connection, you can later change to an Ethernet network connection. If you already understand how to connect to a network, you can use the general directions below.

To change a USB connection to a wired (Ethernet) connection

1. Unplug the USB connection from the back of the HP All-in-One.
2. Connect an Ethernet cable from the Ethernet port on the back of the HP All-in-One to an available Ethernet port on the router or switch.
3. Install the software for a network connection, choose **Add a Device**, and then choose **Through the network**.
4. When the installation is complete, open **Printers and Faxes** (or **Printers**) in the **Control Panel** and delete the printers from the previous USB installation.

Manage your network settings

You can manage network settings for the HP All-in-One through the HP All-in-One control panel. Additional advanced settings are available in the Embedded Web Server, a configuration and status tool you access from your Web browser using an existing network connection to the HP All-in-One.

Change basic network settings from the control panel

You can perform a variety of network management tasks from the control panel, such as printing the network settings and restoring network defaults.

View and print network settings

You can display a summary of the network settings on the HP All-in-One control panel, or you can print a more detailed configuration page. The network configuration page lists all of the important network settings such as the IP address, link speed, DNS, and mDNS.

1. On the control panel of the HP All-in-One, press **Setup**.
2. Press ▼ until **Network** is highlighted, and then press **OK**.
The **Network Menu** appears.
3. Press ▼ until **View Network Settings** is highlighted, and then press **OK**.
The **View Network Settings Menu** appears.
4. Do one of the following:
 - To display wired network settings, press ▼ until **Display Wired Summary** is highlighted, and then press **OK**.
This displays a summary of the wired (Ethernet) network settings.
 - To print the network configuration page, press ▼ until **Print Network Configuration Page** is highlighted, and then press **OK**.
This prints the network configuration page.

Restore network defaults

You can reset the network settings to what they were when you purchased the HP All-in-One.

1. On the control panel of the HP All-in-One, press **Setup**.
2. Press ▼ until **Network** is highlighted, and then press **OK**.
3. Press ▼ until **Restore Network Defaults** is highlighted, and then press **OK**.
4. Press **OK** to confirm that you want to restore the network defaults.

Change advanced network settings from the control panel settings

The advanced network settings are provided for your convenience. However, unless you are an advanced user, you should not change any of these settings.

Set link speed

You can change the speed at which data is transmitted over the network. The default is **Automatic**.

1. Press **Setup**.
2. Press ▼ until **Network** is highlighted, then press **OK**.
The **Network Menu** appears.
3. Press ▼ until **Advanced Setup** is highlighted, and then press **OK**.
Press ▼ until **Set Link Speed** is highlighted, and then press **OK**.
4. Press ▼ to select the link speed that matches your network hardware, and then press **OK** to confirm the setting.
 - **Automatic**
 - **10-Full**
 - **10-Half**
 - **100-Full**
 - **100-Half**

Change IP settings

The default setting for the IP settings is **Automatic**, which sets the IP settings automatically. However, if you are an advanced user, you might want to manually change the IP address, subnet mask, or the default gateway. To see the IP address and subnet mask of the HP All-in-One, print a network configuration page from the HP All-in-One.

 **NOTE:** When manually entering an IP setting, you must already be connected to an active network, otherwise the setting will not stay when you exit from the menu.

 **CAUTION:** Be careful when manually assigning an IP address. If you enter an invalid IP address during the installation, your network components will not be able to connect with the HP All-in-One.

1. Press **Setup**.
2. Press ▼ until **Network** is highlighted, then press **OK**.
The **Network Menu** appears.
3. Press ▼ until **Advanced Setup** is highlighted, and then press **OK**.
4. Press ▼ until **IP Settings** is highlighted, and then press **OK**.
If the HP All-in-One is already connected to a wired network, you are prompted to confirm that you want to change the IP settings. Press **OK**.
5. Press ▼ until **Manual** is highlighted, and then press **OK**.
6. Press ▼ to highlight one of the following IP settings, and then press **OK**.
 - **IP Address**
 - **Subnet Mask**
 - **Default Gateway**
7. Enter your changes, and then press **OK** to confirm the setting.

3 Use the HP All-in-One features

This chapter includes information about how to use the HP All-in-One for basic operations. In addition, it provides instructions about how to load paper and replace the ink cartridges.

Load originals and load paper

You can load many different types and sizes of paper in the HP All-in-One, including letter or A4 paper, legal paper, photo paper, transparencies, envelopes, and HP CD/DVD tattoo labels. By default, the HP All-in-One is set to detect the size and type of paper you load in the input tray automatically and then adjust its settings to generate the highest quality output for that paper.

If you are using special papers, such as photo paper, transparency film, envelopes, or labels, or if you experience poor print quality using the automatically-adjusted settings, you can manually set the paper size and type for print and copy jobs.

Load an original on the glass

You can copy or scan up to letter- or A4-size originals by loading them on the glass.

To load an original on the scanner glass

1. Lift the lid on the HP All-in-One.
2. Load your original print side down on the right front corner of the glass.

 **TIP:** For more help on loading an original, refer to the engraved guides along the edge of the glass.

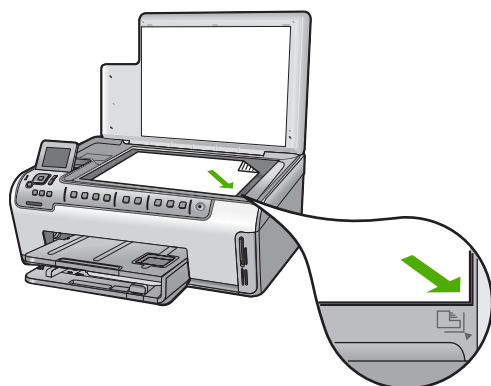

3. Close the lid.

Load full-size paper

You can load many types of letter, A4, or legal paper into the main input tray of the HP All-in-One.

To load full-size paper

1. Pull out the main input tray, and then slide the paper-width and paper-length guides to their outermost positions.

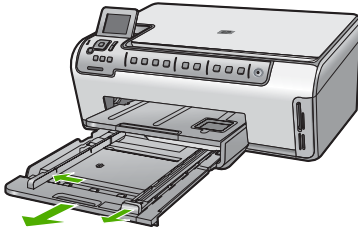

2. Tap a stack of paper on a flat surface to align the edges, and then check the paper for the following:
 - Make sure it is free of rips, dust, wrinkles, and curled or bent edges.
 - Make sure all the paper in the stack is the same size and type.
3. Insert the stack of paper into the main input tray with the short edge forward and the print side down. Slide the stack of paper forward until it stops.

 **TIP:** If you are using letterhead, insert the top of the page first with the print side down. For more help on loading full-size paper and letterhead, refer to the diagram engraved in the base of the input tray.

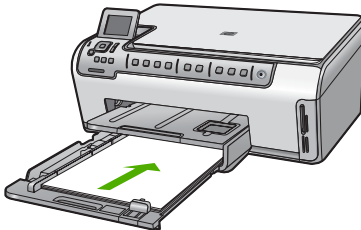

4. Slide the paper-width and paper-length guides inward until they stop at the edges of the paper.
Do not overload the main input tray; make sure the stack of paper fits within the input tray and is no higher than the top of the paper-width guide.

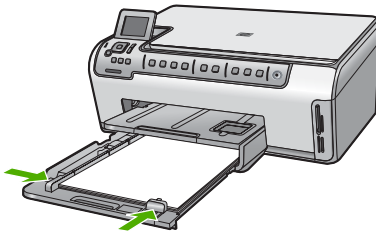

5. Push the main input tray back into the HP All-in-One.
6. Pull the output tray extender toward you, as far as it will go. Flip the paper catch at the end of the output tray extender to open the extender the rest of the way.

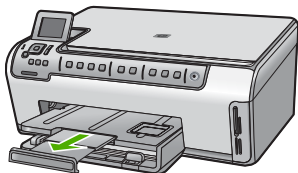

 **NOTE:** When you use legal-size paper, leave the tray extender closed.

Load 10 x 15 cm (4 x 6 inch) photo paper

You can load up to 10 x 15 cm (4 x 6 inch) photo paper into the photo tray of the HP All-in-One. For the best results, use 10 x 15 cm (4 x 6 inch) HP Premium Plus Photo Paper or HP Premium Photo Paper.

To load 10 x 15 cm (4 x 6 inch) photo paper in the photo tray

1. Raise the output tray, and then pull out the photo tray.

 **NOTE:** You can also remove the entire photo tray assembly to load photo paper into the photo tray.

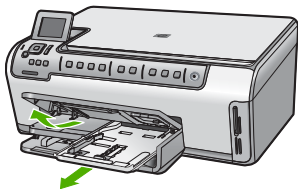

2. Insert the stack of photo paper into the photo tray with the short edge forward and the print side down. Slide the stack of photo paper forward until it stops. If the photo paper you are using has perforated tabs, load the photo paper so that the tabs are closest to you.
3. Slide the paper-length and paper-width guides inward against the stack of photo paper until the guides stop. Do not overload the photo tray; make sure the stack of photo paper fits within the photo tray and is no higher than the top of the paper-width guide.

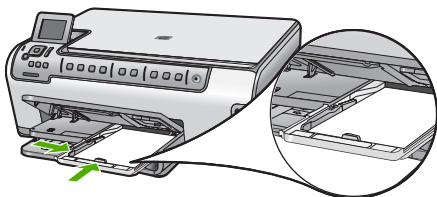

4. Push in the photo tray, and then lower the output tray.

Avoid paper jams

To help avoid paper jams, follow these guidelines.

- Remove printed papers from the output tray frequently.
- Prevent curled or wrinkled paper by storing all unused paper flat in a resealable bag.
- Ensure that paper loaded in the input tray lays flat and the edges are not bent or torn.
- If you are printing labels, ensure that the label sheets are no more than two years old. Labels on older sheets might peel off when the paper is pulled through the HP All-in-One, and cause paper jams.
- Do not combine different paper types and paper sizes in the input tray; the entire stack of paper in the input tray must be the same size and type.
- Adjust the paper-width guide in the input tray to fit snugly against all paper. Make sure the paper-width guide does not bend the paper in the input tray.
- Do not force paper too far forward in the input tray.
- Use paper types that are recommended for the HP All-in-One.

View and select photos

You can view and select photos on your memory card before or while printing them.

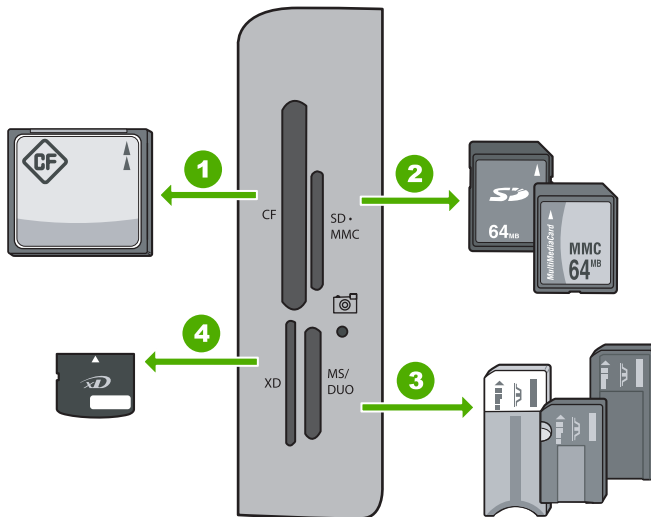

1	CompactFlash (CF) types I and II
2	Secure Digital (SD), Secure Digital Mini (adapter required), Secure Digital High Capacity (SDHC), MultiMediaCard (MMC), MMC Plus, MMC Mobile (RS-MMC; adapter required), TransFlash MicroSD Card, or Secure MultiMedia Card
3	Memory Stick, Memory Stick Pro, Memory Stick Select, Memory Stick Magic Gate, Memory Stick Duo or Duo Pro (adapter optional), or Memory Stick Micro (adapter required)

To view, select, and print photos

1. Insert a memory card into the appropriate slot on the HP All-in-One.
The **Photosmart Express** appears with the most recent photo shown on the display.
2. Load up to 10 x 15 cm (4 x 6 inch) photo paper in the photo tray or full-size photo paper in the main input tray.
3. Press **▶** until **View** is highlighted, and then press **OK**.
The **View Photos** screen appears.
4. Press **◀** or **▶** to scroll through the thumbnails of your photos.
5. When the thumbnail of the photo you want to view is highlighted, press **OK**.
6. When the photo appears by itself on the display, press **OK** again.
The **Photo Options** screen appears.
7. With **Print Preview** highlighted, press **OK**.
The **Print Preview** screen appears, showing how your photo will look when printed.
8. If you want to select additional photos to view and print, press **▼** to highlight **Add More**, press **OK**, and repeat steps 4–6.
Or, once you're in the **Add Photos** screen, the quickest way to select multiple photos (if you don't need the option to edit them) is to press **▲** to select a photo, and then press **◀** or **▶** to scroll through more photos to select.
9. (Optional) If you want to check and/or modify any of your print settings, press **▼** to highlight **Settings**, and then press **OK**.
10. To print the photo(s), use **▲** or **▼** to highlight **Print Now** (or press the **Print Photos** button on the control panel).
A print status screen displays the number of pages to print and the estimated time to complete.

Scan an image

You can start a scan from your computer or from the control panel of the HP All-in-One. This section explains how to scan from the control panel of the HP All-in-One only.

 **NOTE:** You can also use the software you installed with the HP All-in-One to scan images. Using this software, you can edit a scanned image and create special projects using a scanned image.

Scan an original to a computer

You can scan originals placed on the glass by using the control panel.

To scan to a computer

1. Load your original print side down on the right front corner of the glass.
2. Press **Scan Menu**.
3. Press **▼** to highlight **Scan to Computer**, and then press **OK**.

4. If the HP All-in-One is connected to one or more computers on a network, do the following:
 - a. Press **OK** to select **Select Computer**.
A list of the computers connected to the HP All-in-One appears on the display.

 **NOTE:** The **Select Computer** menu might list computers with a USB connection in addition to those connected through the network.

 - b. Press **OK** to select the default computer, or press ▼ to select a different computer, and then press **OK**.
The **Scan To** menu appears on the display, listing the applications on the selected computer.
If the HP All-in-One is connected directly to a computer with a USB cable, proceed to step 5.
5. Press **OK** to select the default application to receive the scan, or press ▼ to select a different application, and then press **OK**.
A preview image of the scan appears on your computer, where you can edit it.
6. Make any edits to the preview image, and then click **Accept** when you are finished.

Scan an original to a memory card

You can send the scanned image as a JPEG image to the memory card that is currently inserted. This enables you to use the photo print options to print borderless prints and album pages from the scanned image.

 **NOTE:** If the HP All-in-One is connected to a network, you can access the scanned image only if the memory card is being shared across the network.

To save a scan to a memory card

1. Make sure your memory card is inserted into the appropriate slot on the HP All-in-One.
2. Load your original print side down on the right front corner of the glass.
3. Press **Scan Menu** on the control panel.
4. Press ▼ to highlight **Scan to Memory Card**, and then press **OK**.

 **NOTE:** Alternatively, you can press **Start Scan** instead of **OK**.

The HP All-in-One scans the image and saves the file to the memory card in the JPEG format.

Make a copy

You can make quality copies from the control panel.

To make a copy from the control panel

1. Make sure you have paper loaded in the input tray.
2. Load your original print side down on the right front corner of the glass.
3. Press **Start Copy Black** or **Start Copy Color** to begin copying.

Replace the ink cartridges

Follow these instructions when you need to replace ink cartridges.

NOTE: If you are installing ink cartridges in the HP All-in-One for the first time, be sure to use only the ink cartridges that came with the device. The ink in these cartridges is specially formulated to mix with the ink in the print head assembly at first-time setup.

If you do not already have replacement ink cartridges for the HP All-in-One, you can order them by clicking the **Shop for HP Supplies** icon on your computer. On a Windows computer this is located in the **HP** folder in the **Start** menu.

For more information see www.hp.com/buy/supplies.

To replace the ink cartridges

1. Make sure the HP All-in-One is turned on.
2. Open the ink cartridge door by lifting from the front center of the device, until the door locks into place.

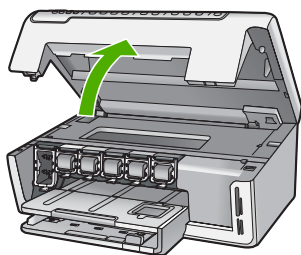

3. Squeeze the bottom of the latch below the ink cartridge you want to replace, and then lift the latch.

If you are replacing the black ink cartridge, lift the latch on the far left.

If you are replacing one of the five color ink cartridges, such as yellow, light cyan (blue), cyan, light magenta (pink), or magenta, lift the appropriate latch in the center area.

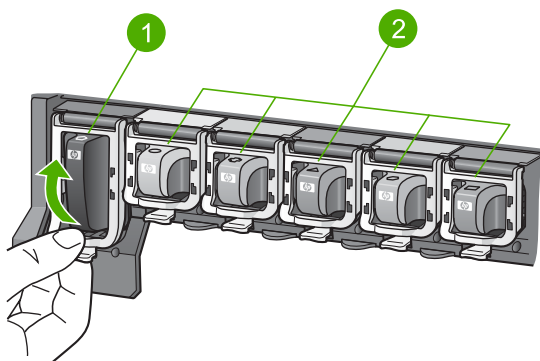

- | | |
|---|--|
| 1 | Ink cartridge latch for the black ink cartridge |
| 2 | Ink cartridge latches for the color ink cartridges |

4. Pull the ink cartridge toward you out of its slot to remove it.

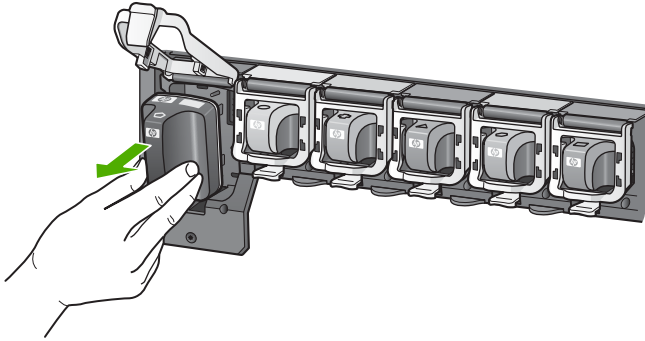

5. Remove the new ink cartridge from its packaging, and then, holding it by the handle, push the ink cartridge into the empty slot. Match the color and pattern of the ink cartridge to the color and pattern on the print carriage.

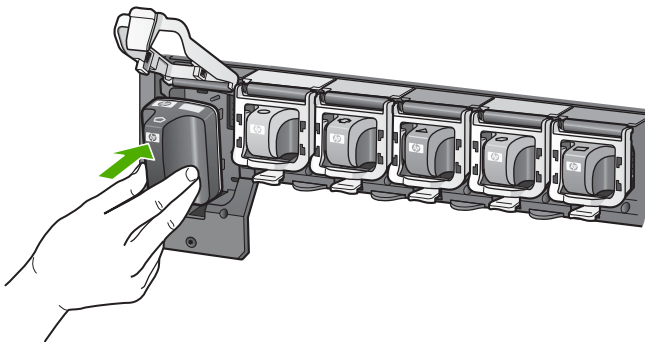

6. Close the latch and make sure it is secure.

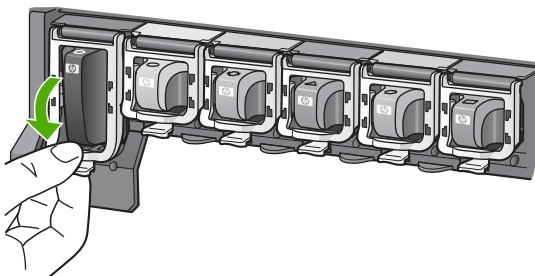

7. Repeat steps 3 through 6 for each ink cartridge you are replacing.
8. Close the ink cartridge door.

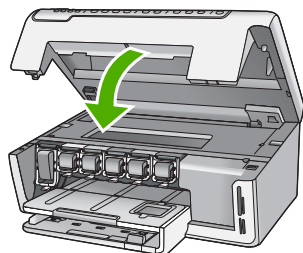

Clean the HP All-in-One

To ensure that your copies and scans remain clear, you might need to clean the glass and lid backing. You might also want to dust the exterior of the HP All-in-One.

TIP: You can purchase an HP Cleaning Kit for Inkjet Printers and All-in-Ones (Q6260A) that provides everything needed to safely clean your HP device. For more information, go to: www.shopping.hp.com/accessories-store/printer.

Clean the glass

Fingerprints, smudges, hair, and dust on the main glass surface slow down performance and affect the accuracy of the copy and scan features.

To clean the glass

1. Turn off the HP All-in-One, and raise the lid.
2. Clean the glass with a soft cloth or sponge slightly moistened with a nonabrasive glass cleaner.

CAUTION: Do not use abrasives, acetone, benzene, or carbon tetrachloride on the glass, since they can damage it. Do not place or spray liquid directly on the glass. The liquid might seep under the glass and damage the device.

3. Dry the glass with a dry, soft, lint-free cloth to prevent spotting.
4. Turn on the HP All-in-One.

Clean the lid backing

Minor debris can accumulate on the white document backing located underneath the lid of the HP All-in-One.

To clean the lid backing

1. Turn off the HP All-in-One, and raise the lid.
2. Clean the white document backing with a soft cloth or sponge slightly moistened with a mild soap and warm water.

Wash the backing gently to loosen debris. Do not scrub the backing.

3. Dry the backing with a dry, soft, lint-free cloth.

△ **CAUTION:** Do not use paper-based wipes, as these might scratch the backing.

4. If further cleaning is needed, repeat the previous steps using isopropyl (rubbing) alcohol, and wipe the backing thoroughly with a damp cloth to remove any residual alcohol.

△ **CAUTION:** Be careful not to spill alcohol on the glass or exterior of the HP All-in-One, as this might damage the device.

4 Troubleshooting and support

This chapter contains troubleshooting information for the HP All-in-One. Specific information is provided for installation and configuration issues, and some operational topics. For more troubleshooting information, see the onscreen Help that came with your software.

This chapter also provides warranty and support information. For support contact information, see the inside back cover of this guide.

Many issues are caused when the HP All-in-One is connected to the computer using a USB cable before the HP All-in-One software is installed on the computer. If you connected the HP All-in-One to your computer before the software installation screen prompts you to do so, you must follow these steps:

Troubleshooting common setup issues

1. Disconnect the USB cable from the computer.
2. Uninstall the software (if you have already installed it).
3. Restart your computer.
4. Turn off the HP All-in-One, wait one minute, then turn it on.
5. Reinstall the HP All-in-One software.

 **CAUTION:** Do not connect the USB cable to the computer until prompted by the software installation screen.

Uninstall and reinstall the software

If your installation is incomplete, or if you connected the USB cable to the computer before prompted by the software installation screen, you might need to uninstall and then reinstall the software. Do not simply delete the HP All-in-One application files from your computer. Make sure to remove them properly using the uninstall utility provided when you installed the software that came with the HP All-in-One.

To uninstall from a Windows computer and then reinstall

1. On the Windows taskbar, click **Start, Settings, Control Panel** (or just **Control Panel**).
2. Double-click **Add/Remove Programs** (or click **Uninstall a program**).
3. Select **HP Photosmart Driver Software**, and then click **Change/Remove**. Follow the onscreen instructions.
4. Disconnect the HP All-in-One from your computer.
5. Restart your computer.



NOTE: It is important that you disconnect the HP All-in-One before restarting your computer. Do not connect the HP All-in-One to your computer until after you have reinstalled the software.

6. Insert the HP All-in-One CD-ROM into your computer's CD-ROM drive and then start the Setup program.
7. Follow the onscreen instructions and the instructions provided in the Setup Guide that came with the HP All-in-One.

Hardware setup troubleshooting

Use this section to solve any problems you might encounter while setting up the HP All-in-One hardware.

The HP All-in-One will not turn on

Cause: The HP All-in-One is not properly connected to a power supply.

Solution

- Make sure the power cord is firmly connected to both the HP All-in-One and the power adapter. Plug the power cord into a grounded power outlet, surge protector, or power strip.

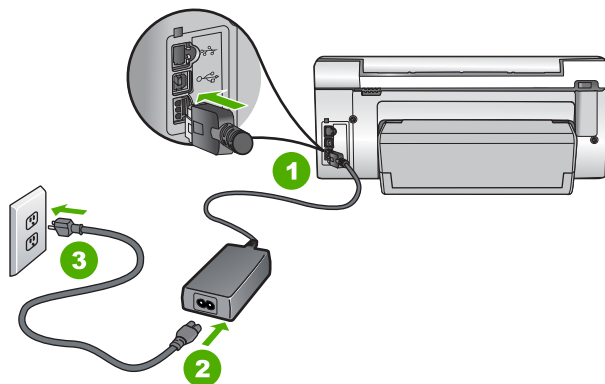

1	Power connection
2	Power cord and adapter
3	Grounded power outlet

- If you are using a power strip, make sure the power strip is on. Or, try plugging the HP All-in-One directly into a grounded power outlet.
- Test the power outlet to make sure it is working. Plug in an appliance that you know works, and see if the appliance has power. If not, then there might be a problem with the power outlet.
- If you plugged the HP All-in-One into a switched outlet, make sure the switch is on. If it is switched to on but still does not work, then there might be a problem with the power outlet.

Cause: You pressed the **On** button too quickly.

Solution: The HP All-in-One might not respond if you press the **On** button too quickly. Press the **On** button once. It might take a few minutes for the HP All-in-One to turn on. If you press the **On** button again during this time, you might turn the device off.

△ **CAUTION:** If the HP All-in-One still does not turn on, it might have a mechanical failure. Unplug the HP All-in-One from the power outlet and contact HP. Go to: www.hp.com/support. If prompted, choose your country/region, and then click **Contact HP** for information on calling for technical support.

I connected the USB cable, but I am having problems using the HP All-in-One with my computer

Cause: The USB cable was connected before the software was installed. Connecting the USB cable before prompted can cause errors.

Solution: You must first install the software that came with the HP All-in-One before connecting the USB cable. During installation, do not plug in the USB cable until prompted by the onscreen instructions.

Once you have installed the software, connecting your computer to the HP All-in-One with a USB cable is straightforward. Simply plug one end of the USB cable into the back of your computer and the other into the back of the HP All-in-One. You can connect to any USB port on the back of your computer.

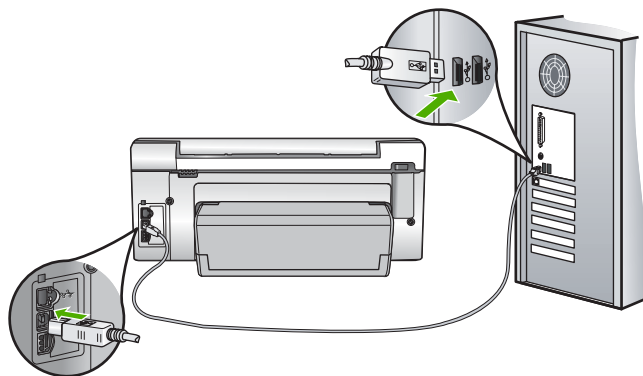

For more information on installing the software and connecting the USB cable, see the Setup Guide that came with the HP All-in-One.

The HP All-in-One does not print

Solution: If the HP All-in-One and computer are not communicating with each other, try the following:

- Look at the **On** light located on the front of the HP All-in-One. If it is not lit, the HP All-in-One is turned off. Make sure the power cord is firmly connected to the HP All-in-One and plugged into a power outlet. Press the **On** button to turn on the HP All-in-One.
- Make sure the ink cartridges are installed.
- Make sure you have paper loaded in the input tray.
- Check that the HP All-in-One does not have a paper jam.
- Check that the print carriage is not jammed.
Open the ink cartridge door to access the print carriage area. Remove any objects that are blocking the print carriage, including any packing materials. Turn the HP All-in-One off and then turn it on again.
- Check that the HP All-in-One print queue is not paused (Windows) or stopped (Mac). If it is, choose the appropriate setting to resume printing. For more information about accessing the print queue, see the documentation that came with the operating system installed on your computer.
- Check the USB cable. If you are using an older cable, it might not be working properly. Try connecting it to another product to see if the USB cable works. If you experience problems, the USB cable might need to be replaced. Also verify that the cable does not exceed 3 meters (9.8 feet) in length.
- Make sure your computer is USB ready. Some operating systems, such as Windows 95 and Windows NT, do not support USB connections. Check the documentation that came with your operating system for more information.
- Check the connection from the HP All-in-One to your computer. Verify that the USB cable is securely plugged into the USB port on the back of the HP All-in-One. Make sure the other end of the USB cable is plugged into a USB port on your computer. After the cable is connected properly, turn the HP All-in-One off and then on again.
- If you are connecting the HP All-in-One through a USB hub, make sure the hub is turned on. If the hub is on, try connecting directly to your computer.
- Check other printers or scanners. You might need to disconnect older products from your computer.
- Try connecting the USB cable to another USB port on your computer. After you check the connections, try restarting your computer. Turn the HP All-in-One off and then on again.

- If the HP All-in-One is offline, turn the HP All-in-One off and on again. Start a print job.
 - If necessary, remove and then install the software you installed with the HP All-in-One again.
- For more information on setting up the HP All-in-One and connecting it to your computer, see the Setup Guide that came with the HP All-in-One.

Network troubleshooting

This section addresses problems you might encounter setting up a wired network.

The computer is unable to discover the HP All-in-One

Cause: Cables are not connected properly.

Solution: Check the following cables to ensure they are connected properly.

- Cables between the HP All-in-One and the hub or router
- Cables between the hub or router and your computer
- Cables to and from your modem or HP All-in-One Internet connection (if applicable)

Cause: Your computer's Local Area Network card (LAN card) is not set up properly.

Solution: Make sure that your LAN card is set up properly.

To check your LAN card (Windows 2000 and XP)

1. Right-click **My Computer**.
2. In the **System Properties** dialog box, click the **Hardware** tab.
3. Click **Device Manager**.
4. Make sure your card shows up under **Network Adapters**.
5. Refer to the documentation that came with your card.

To check your LAN card (Windows Vista)

1. On the Windows taskbar, click **Start, Computer**, and then click **Properties**.
2. Click **Device Manager**.
3. Make sure your card shows up under **Network Adapters**.
4. Refer to the documentation that came with your card.

Cause: You do not have an active network connection.

Solution: Check to see if you have an active network connection.

To see if you have an active network connection

- ▲ Check the two Ethernet indicator lights on the top and bottom of the RJ-45 Ethernet jack on the back of the HP All-in-One. The lights indicate the following:
 - a. Top light: If this light is a solid green, the device is properly connected to the network, and communications have been established. If the top light is off, there is no network connection.
 - b. Bottom light: This yellow light flashes when data is being sent or received by the device over the network.

To establish an active network connection

1. Check the cable connections from the HP All-in-One to your gateway, router, or hub to ensure connections are secure.
2. If the connections are secure, press the **On** button on the control panel to turn the HP All-in-One off. Then turn off the power on your router or hub. Turn on the router or hub first, and then press the **On** button to turn the HP All-in-One on.

Cause: You were able to connect the HP All-in-One to the network previously, but now it will not connect.

Solution: Turn off the HP All-in-One, the computer, and the router. Wait a few seconds. Turn on the router first, and then turn on the HP All-in-One and the computer.

Cause: The HP All-in-One and computer are not connected to the same network.

Solution: Try accessing the Embedded Web Server on the HP All-in-One. To find the IP address, print a network configuration page.

The Printer not Found screen appears during installation

Cause: The HP All-in-One is not turned on.

Solution: Turn on the HP All-in-One.

Cause: You do not have an active network connection.

Solution: Make sure you have an active network connection.

To make sure your network connection is active

1. If the connections are secure, turn off the power on the HP All-in-One, and then turn it on again. Press the **On** button on the control panel to turn the HP All-in-One off, and press it again to turn the device on. Also, turn off the power on your router or hub, and then turn it on again.
2. Check the cable connections from the HP All-in-One to your gateway, router, or hub to ensure connections are secure.
3. Make sure the HP All-in-One is connected to the network with a CAT-5 Ethernet cable.

Cause: Cables are not connected properly.

Solution: Check the following cables to ensure they are connected properly:

- Cables between the HP All-in-One and the hub or router
- Cables between the hub or router and your computer
- Cables to and from your modem or HP All-in-One Internet connection (if applicable)

Cause: A firewall, anti-virus, or anti-spyware application is preventing the HP All-in-One from accessing your computer.

Solution: Uninstall the HP All-in-One software, and then restart your computer. Temporarily disable anti-virus or anti-spyware applications, and then reinstall the HP All-in-One software. You can re-enable your anti-virus or anti-spyware applications after installation is complete. If you see firewall pop-up messages, you must always accept or allow the pop-up messages. If the screen still appears, try uninstalling the HP All-in-One software, restarting your computer, and temporarily disabling your firewall before reinstalling the HP All-in-One software. You can re-enable your firewall application after installation is complete. If you still see firewall pop-up messages, you must always accept or allow the pop-up messages.

For more information, see the documentation provided with the firewall software.

Cause: A Virtual Private Network (VPN) is preventing the HP All-in-One from accessing your computer.

Solution: Try temporarily disabling the VPN before proceeding with the installation.



NOTE: The HP All-in-One functionality will be limited during VPN sessions.

Clear paper jams

If the HP All-in-One has a paper jam, check the Two-sided printing accessory.

To clear a paper jam from the Two-sided printing accessory

1. Turn off the HP All-in-One.
2. Press in the tabs on the left and right side of the Two-sided printing accessory. Remove the accessory by pulling it away from the HP All-in-One.

△ **CAUTION:** Trying to clear a paper jam from the front of the HP All-in-One can damage the print mechanism. Always access and clear paper jams from the Two-sided printing accessory of the HP All-in-One.

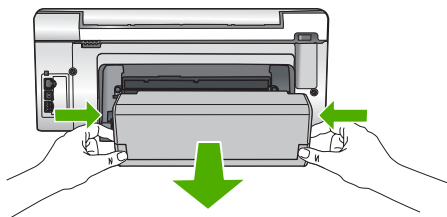

3. Gently pull the paper out of the rollers.

△ **CAUTION:** If the paper tears when you are removing it from the rollers, check the rollers and wheels for torn pieces of paper that might be remaining inside the device. If you do not remove all the pieces of paper from the HP All-in-One, more paper jams are likely to occur.

4. If the paper jam is cleared, proceed to step 5.
If the paper jam is not cleared, do the following:
 - a. Open the Two-sided printing accessory by pulling the tabs up.
 - b. Remove any paper from inside the accessory.
 - c. Close the Two-sided printing accessory by pressing the tabs down until they lock into place.
5. Replace the Two-sided printing accessory. Gently push the accessory forward until it snaps into place.
6. Turn on the HP All-in-One, and then press **OK** to continue the current job.

Information on ink cartridges and the print head

The following tips help maintain HP ink cartridges and ensure consistent print quality.

- Install the ink cartridge on or before the install by date, which is printed on the ink cartridge package.
- Keep all ink cartridges in the original sealed packages until they are needed.
- Turn off the HP All-in-One by pressing the **On** button located on the device. Do not turn off the device by turning off a power strip or unplugging the power cord from the HP All-in-One. If you improperly turn off the HP All-in-One, the print head assembly might not return to the correct position.
- Store ink cartridges at room temperature (15.6°-26.6° C or 60°-78° F).
- HP recommends that you do not remove the ink cartridges from the HP All-in-One until you have replacement cartridges available to install.

If you are transporting the HP All-in-One make sure you turn off the device by pressing the **On** button to power it down properly. Also, make sure you leave the ink cartridges installed. Doing these actions will prevent ink leaking from the print head assembly.

- Clean the print head when you notice a significant decrease in print quality.
- Do not clean the print head unnecessarily. This wastes ink and shortens the life of the cartridges.
- Handle ink cartridges carefully. Dropping, jarring, or rough handling during installation can cause temporary printing problems.

Support process

If you have a problem, follow these steps:

1. Check the documentation that came with the HP All-in-One.
2. Visit the HP online support Web site at www.hp.com/support. HP online support is available to all HP customers. It is the fastest source for up-to-date device information and expert assistance and includes the following features:
 - Fast access to qualified online support specialists
 - Software and driver updates for the HP All-in-One
 - Valuable HP All-in-One and troubleshooting information for common problems
 - Proactive device updates, support alerts, and HP newsgrams that are available when you register the HP All-in-One
3. Call HP support. Support options and availability vary by device, country/region, and language. For a list of support phone numbers, see the inside back cover of this guide.

5 Technical information

The technical specifications and international regulatory information for the HP All-in-One are provided in this section.

System requirements

Software system requirements are located in the Readme file.

Product specifications

For product specifications, go to the HP Web site at www.hp.com/support.

Paper specifications

- Input tray capacity: Plain paper sheets: Up to 125 (20 lb./75 gsm. paper)
- Output tray capacity: Plain paper sheets: Up to 50 (20 lb./75 gsm. paper)
- Photo tray capacity: 10 x 15 cm (4 x 6 inch) Photo paper: Up to 25(145 lb /236 gsm paper)

 **NOTE:** For a complete list of supported media sizes, see the printer software.

Physical specifications

- Height: 24.1 cm (9.5 inches)
- Width: 45 cm (17.7 inches)
- Depth: 44.3 cm (17.4 inches)
- Weight: 11 kg (24.3 lbs)

Power specifications

- Power consumption: 32.5 W (Peak) 20.1 W (Average)
- Input voltage: AC 100 to 240 V ~1A 50–60 Hz
- Output voltage: DC 32 V===1560 mA

 **NOTE:** Use only with the power adapter supplied by HP.

NOTE: When the HP All-in-One is off, some amount of energy is still being consumed. Energy consumption can be lessened by enabling the Standby/Off state. To enable the Standby/Off state, press and hold the **On** button for 3 seconds until the HP All-in-One turns off. When the HP All-in-One is in the Standby/Off state, it will take longer than usual to turn back on.

Environmental specifications

- Recommended operating temperature range: 15° to 32 °C (59° to 90 °F)
- Allowable operating temperature range: 5° to 40° C (41° to 104° F)
- Humidity: 20% to 80% RH non-condensing
- Non-operating (Storage) temperature range: –20° to 60° C (–4° to 140° F)
- In the presence of high electromagnetic fields, it is possible the output from the HP All-in-One may be slightly distorted
- HP recommends using a USB cable less than or equal to 3 m (10 feet) in length to minimize injected noise due to potential high electromagnetic fields

Ink cartridge yield

Ink from the cartridges is used in the printing process in a number of different ways, including in the initialization process, which prepares the device and cartridges for printing, and in printhead servicing, which keeps print nozzles clear and ink flowing smoothly. In addition, some residual ink is left in the cartridge after it is used. For more information, see www.hp.com/go/inkusage.

Visit www.hp.com/pageyield for more information on estimated cartridge yields.

Regulatory notices

The HP All-in-One meets product requirements from regulatory agencies in your country/region. For a complete listing of regulatory notices, see the onscreen Help.

Regulatory model identification number

For regulatory identification purposes, your product is assigned a Regulatory Model Number. The Regulatory Model Number for your product is SDGOB-0714. This regulatory number should not be confused with the marketing name (HP Photosmart C6200 All-in-One series, etc.) or product numbers (CC985A, etc.).

Warranty

HP product	Duration of limited warranty
Software Media	90 days
Printer	1 year
Print or Ink cartridges	Until the HP ink is depleted or the "end of warranty" date printed on the cartridge has been reached, whichever occurs first. This warranty does not cover HP ink products that have been refilled, remanufactured, refurbished, misused, or tampered with.
Accessories	1 year unless otherwise stated

A. Extent of limited warranty

- Hewlett-Packard (HP) warrants to the end-user customer that the HP products specified above will be free from defects in materials and workmanship for the duration specified above, which duration begins on the date of purchase by the customer.
- For software products, HP's limited warranty applies only to a failure to execute programming instructions. HP does not warrant that the operation of any product will be interrupted or error free.
- HP's limited warranty covers only those defects that arise as a result of normal use of the product, and does not cover any other problems, including those that arise as a result of:
 - Improper maintenance or modification;
 - Software, media, parts, or supplies not provided or supported by HP;
 - Operation outside the product's specifications;
 - Unauthorized modification or misuse.
- For HP printer products, the use of a non-HP cartridge or a refilled cartridge does not affect either the warranty to the customer or any HP support contract with the customer. However, if printer failure or damage is attributable to the use of a non-HP or refilled cartridge or an expired ink cartridge, HP will charge its standard time and materials charges to service the printer for the particular failure or damage.
- If HP receives, during the applicable warranty period, notice of a defect in any product which is covered by HP's warranty, HP shall either repair or replace the product, at HP's option.
- If HP is unable to repair or replace, as applicable, a defective product which is covered by HP's warranty, HP shall, within a reasonable time after being notified of the defect, refund the purchase price for the product.
- HP shall have no obligation to repair, replace, or refund until the customer returns the defective product to HP.
- Any replacement product may be either new or like-new, provided that it has functionality at least equal to that of the product being replaced.
- HP products may contain remanufactured parts, components, or materials equivalent to new in performance.
- HP's Limited Warranty Statement is valid in any country where the covered HP product is distributed by HP. Contracts for additional warranty services, such as on-site service, may be available from any authorized HP service facility in countries where the product is distributed by HP or by an authorized importer.

B. Limitations of warranty

TO THE EXTENT ALLOWED BY LOCAL LAW, NEITHER HP NOR ITS THIRD PARTY SUPPLIERS MAKES ANY OTHER WARRANTY OR CONDITION OF ANY KIND, WHETHER EXPRESS OR IMPLIED WARRANTIES OR CONDITIONS OF MERCHANTABILITY, SATISFACTORY QUALITY, AND FITNESS FOR A PARTICULAR PURPOSE.

C. Limitations of liability

- To the extent allowed by local law, the remedies provided in this Warranty Statement are the customer's sole and exclusive remedies.
- TO THE EXTENT ALLOWED BY LOCAL LAW, EXCEPT FOR THE OBLIGATIONS SPECIFICALLY SET FORTH IN THIS WARRANTY STATEMENT, IN NO EVENT SHALL HP OR ITS THIRD PARTY SUPPLIERS BE LIABLE FOR DIRECT, INDIRECT, SPECIAL, INCIDENTAL, OR CONSEQUENTIAL DAMAGES, WHETHER BASED ON CONTRACT, TORT, OR ANY OTHER LEGAL THEORY AND WHETHER ADVISED OF THE POSSIBILITY OF SUCH DAMAGES.

D. Local law

- This Warranty Statement gives the customer specific legal rights. The customer may also have other rights which vary from state to state in the United States, from province to province in Canada, and from country to country elsewhere in the world.
- To the extent that this Warranty Statement is inconsistent with local law, this Warranty Statement shall be deemed modified to be consistent with such local law. Under such local law, certain disclaimers and limitations of this Warranty Statement may not apply to the customer. For example, some states in the United States, as well as some governments outside the United States (including provinces in Canada), may:
 - Preclude the disclaimers and limitations in this Warranty Statement from limiting the statutory rights of a consumer (e.g., the United Kingdom);
 - Otherwise restrict the ability of a manufacturer to enforce such disclaimers or limitations; or
 - Grant the customer additional warranty rights, specify the duration of implied warranties which the manufacturer cannot disclaim, or allow limitations on the duration of implied warranties.
- THE TERMS IN THIS WARRANTY STATEMENT, EXCEPT TO THE EXTENT LAWFULLY PERMITTED, DO NOT EXCLUDE, RESTRICT, OR MODIFY, AND ARE IN ADDITION TO, THE MANDATORY STATUTORY RIGHTS APPLICABLE TO THE SALE OF THE HP PRODUCTS TO SUCH CUSTOMERS.

HP Limited Warranty

Dear Customer,

You will find below the name and address of the HP entity responsible for the performance of the HP Limited Warranty in your country.

You may have additional statutory rights against the seller based on your purchase agreement. Those rights are not in any way affected by this HP Limited Warranty.

Ireland: Hewlett-Packard Ireland Ltd. 30 Herbert Street IRL-Dublin 2

United Kingdom: Hewlett-Packard Ltd, Cain Road, Bracknell, GB-Berks RG12 1HN



www.hp.com/support

Africa (English speaking)	+27 11 2345872	
Afrique (francophone)	+33 1 4993 9230	
	021 67 22 80	الجزائر
Argentina (Buenos Aires)	54-11-4708-1600	
Argentina	0-800-555-5000	
Australia	www.hp.com/support/australia	
Österreich	www.hp.com/support	
	17212049	البحرين
België	www.hp.com/support	
Belgique	www.hp.com/support	
Brasil (Sao Paulo)	55-11-4004-7751	
Brasil	0-800-709-7751	
Canada	1-(800)-474-6836 (1-800 hp invent)	
Central America & The Caribbean	www.hp.com/support	
Chile	800-360-999	
中国	www.hp.com/support/china	
Colombia (Bogotá)	571-606-9191	
Colombia	01-8000-51-4746-8368	
Costa Rica	0-800-011-1046	
Česká republika	810 222 222	
Danmark	www.hp.com/support	
Ecuador (Andinatel)	1-999-119 ☎ 800-711-2884	
Ecuador (Pacifitel)	1-800-225-528 ☎ 800-711-2884	
	(02) 6910602	مصر
El Salvador	800-6160	
España	www.hp.com/support	
France	www.hp.com/support	
Deutschland	www.hp.com/support	
Ελλάδα (από το εξωτερικό)	+ 30 210 6073603	
Ελλάδα (εντός Ελλάδας)	801 11 75400	
Ελλάδα (από Κύπρο)	800 9 2654	
Guatemala	1-800-711-2884	
香港特別行政區	www.hp.com/support/hongkong	
Magyarország	06 40 200 629	
India	www.hp.com/support/india	
Indonesia	www.hp.com/support	
	+971 4 224 9189	العراق
	+971 4 224 9189	الكويت
	+971 4 224 9189	لبنان
	+971 4 224 9189	قطر
	+971 4 224 9189	اليمن
Ireland	www.hp.com/support	
	1-700-503-048	ישראל
Italia	www.hp.com/support	
Jamaica	1-800-711-2884	

日本	www.hp.com/support/japan	
	0800 222 47	الأردن
한국	www.hp.com/support/korea	
Luxembourg	www.hp.com/support	
Malaysia	www.hp.com/support	
Mauritius	(262) 262 210 404	
México (Ciudad de México)	55-5258-9922	
México	01-800-472-68368	
	081 005 010	المغرب
Nederland	www.hp.com/support	
New Zealand	www.hp.com/support	
Nigeria	(01) 271 2320	
Norge	www.hp.com/support	
	24791773	نمسا
Panamá	1-800-711-2884	
Paraguay	009 800 54 1 0006	
Perú	0-800-10111	
Philippines	www.hp.com/support	
Polska	0801 800 235	
Portugal	www.hp.com/support	
Puerto Rico	1-877-232-0589	
República Dominicana	1-800-711-2884	
Reunion	0820 890 323	
România	0801 033 390	
Россия (Москва)	+7 495 7773284	
Россия (Санкт-Петербург)	+7 812 3324240	
	800 897 1415	السعودية
Singapore	www.hp.com/support/singapore	
Slovensko	0850 111 256	
South Africa (RSA)	0860 104 771	
Suomi	www.hp.com/support	
Sverige	www.hp.com/support	
Switzerland	www.hp.com/support	
臺灣	www.hp.com/support/taiwan	
ໄທ	www.hp.com/support	
	071 891 391	تونس
Trinidad & Tobago	1-800-711-2884	
Türkiye	+90 (212)291 38 65	
Україна	(044) 230-51-06	
	600 54 47 47	الإمارات العربية المتحدة
United Kingdom	www.hp.com/support	
United States	1-(800)-474-6836 (1-800 hp invent)	
Uruguay	0004-054-177	
Venezuela (Caracas)	58-212-278-8666	
Venezuela	0-800-474-68368	
Việt Nam	www.hp.com/support	