

Multimedia User Guide

© Copyright 2007 Hewlett-Packard
Development Company, L.P.

Windows is a U.S. registered trademark of
Microsoft Corporation.

The information contained herein is subject
to change without notice. The only
warranties for HP products and services are
set forth in the express warranty statements
accompanying such products and services.
Nothing herein should be construed as
constituting an additional warranty. HP shall
not be liable for technical or editorial errors
or omissions contained herein.

First Edition: December 2007

Document Part Number: 459898-001

Product notice

This user guide describes features that are common to most models. Some features may not be available on your computer.

Table of contents

1 Using multimedia hardware

Using the audio features	1
Using the audio-in (microphone) jack	2
Using the audio-out (headphone) jack	2
Adjusting the volume	3
Using the video features	4
Using the external monitor port	4
Using the S-Video-out jack	5
Using the webcam	6
Adjusting webcam properties	8
Using an optical drive	9
Identifying the installed optical drive	9
Inserting an optical disc (CD or DVD)	9
Removing an optical disc (CD or DVD)	10
When the disc tray opens	10
When the disc tray does not open	10
Using the media activity hotkeys	12

2 Working with multimedia software

Opening preinstalled multimedia software	14
Installing multimedia software from a disc	14
Using multimedia software	14
Preventing playback disruptions	15
Changing DVD region settings	16
Observing the copyright warning	16

Index	17
-------------	----

1 Using multimedia hardware

Using the audio features

The following illustration and table describe the audio features of the computer.



Component	Description
(1) Speakers (2)	Produce computer sound.
(2) Audio-out (headphone) jack	Connects optional powered stereo speakers, headphones, ear buds, headset, or television audio.
(3) Audio-in (microphone) jack	Connects an optional computer headset or microphone.
(4) Volume down hotkey	Press fn+pg dn to decrease speaker volume.
(5) Volume up hotkey	Press fn+pg up to increase speaker volume.
(6) Volume mute hotkey	Press fn+home to mute and restore speaker sound.
(7) Internal microphone	Records sound.

Using the audio-in (microphone) jack

The computer is equipped with a stereo (dual-channel) microphone jack that supports an optional stereo array or monaural microphone. Using sound recording software with external microphones allows for stereo recordings.

When connecting a microphone to the microphone jack, use a microphone with a 3.5-mm plug.

Using the audio-out (headphone) jack

⚠ **WARNING!** To reduce the risk of personal injury, adjust the volume before putting on headphones, earbuds, or a headset. For additional safety information, refer to the *Regulatory, Safety and Environmental Notices*.

⚠ **CAUTION:** To prevent possible damage to an external device, do not plug a single sound channel (monaural) connector into the headphone jack.

In addition to connecting headphones, the headphone jack is used to connect the audio-out function of an audio device such as external powered speakers or a stereo system.

When connecting a device to the headphone jack, use only a 3.5-mm stereo plug.

When a device is connected to the headphone jack, the speakers are disabled.

Adjusting the volume

You can adjust the volume using the following controls:

- Computer volume hotkeys:
 - To mute or restore volume, press **fn+home** (1).
 - To increase volume, press **fn+pg up** (2).
 - To decrease volume, press **fn+pg dn** (3).

 **NOTE:** The tapping sound made by the volume button is enabled at the factory. You can disable the sound in the Setup Utility (f10).

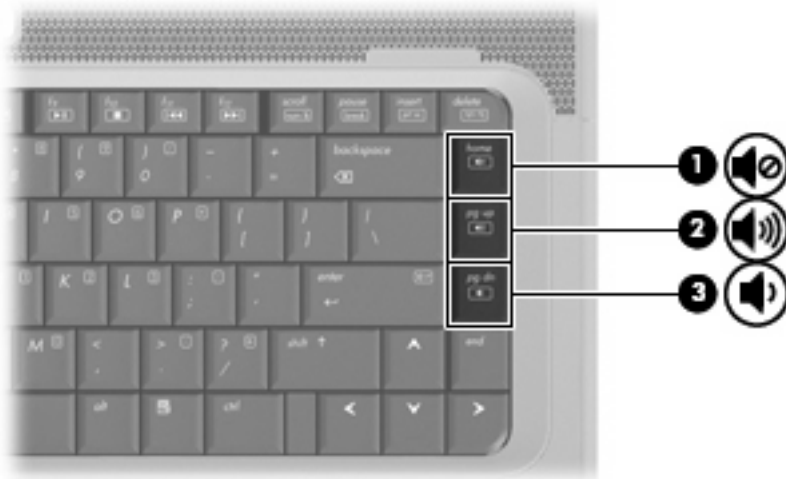

- Windows® volume control:
 - a. Click the **Volume** icon in the notification area, at the far right of the taskbar.
 - b. Increase or decrease the volume by moving the slider up or down. Click the **Mute** icon to mute the volume.

– or –

- a. Right-click the **Volume** icon in the notification area, and then click **Open Volume Mixer**.
- b. In the Speakers column, increase or decrease the volume by moving the slider up or down. You can also mute the volume by clicking the **Mute** icon.

If the Volume icon is not displayed in the notification area, follow these steps to add it:

- a. Right-click in the notification area, and then click **Properties**.
 - b. Click the **Notification Area** tab.
 - c. Under System icons, select the **Volume** check box.
 - d. Click **OK**.
- Program volume control:

Volume can also be adjusted within some programs.

Using the video features

Using the external monitor port

The external monitor port connects an external display device, such as an external monitor or a projector, to the computer.

- ▲ To connect a display device, connect the device cable to the external monitor port.

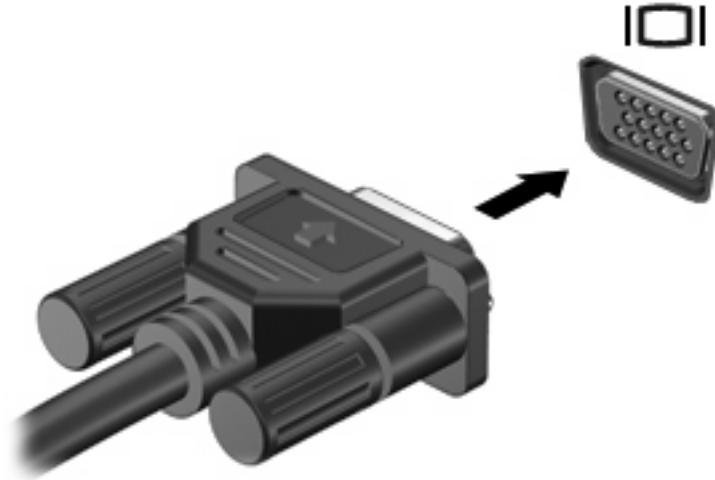

 **NOTE:** If a properly connected external display device does not display an image, press **fn+f4** to transfer the image to the device. Repeatedly pressing **fn+f4** alternates the screen image between the computer display and the device.

Using the S-Video-out jack

The 7-pin S-Video-out jack connects the computer to an optional S-Video device such as a television, VCR, camcorder, overhead projector, or video capture card.

To transmit video signals through the S-Video-out jack, you need an S-Video cable, available from most electronics retailers. If you are combining audio and video functions, such as playing a DVD movie on your computer and displaying it on your television, you also need a standard audio cable, available from most electronics retailers, to connect to the headphone jack.

The computer can support one S-Video device connected to the S-Video-out jack, while simultaneously supporting an image on the computer display or on any other supported external display.

 **NOTE:** The S-Video connection provides a higher quality image than a composite-video connection.

To connect a video device to the S-Video-out jack:

1. Plug one end of the S-Video cable into the S-Video-out jack on the computer.

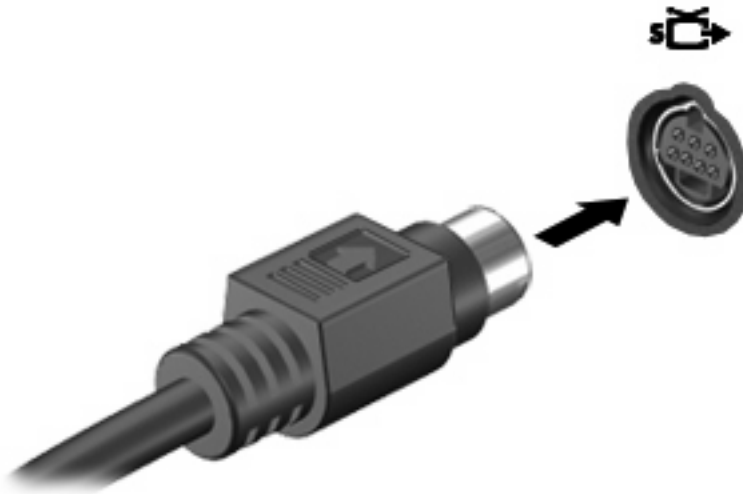

2. Plug the other end of the cable into the video device, as instructed in the user guide included with the device.
3. Press the **fn+f4** keys to switch the image between display devices connected to the computer.

Using the webcam

The computer includes an integrated webcam, located at the top of the display. To access the webcam and CyberLink YouCam software, select **Start > All Programs > CyberLink YouCam > YouCam**.

 **NOTE:** The first time you access the webcam software, you may experience a brief delay as the software loads.

For more information about using the webcam, see the HP Web site at <http://www.hp.com/support>. Select your language and search for `notebook webcam`.

Using YouCam as your default webcam software enables you to experiment with the following features:

- Video—Record and play back webcam video. You can also e-mail or upload video to YouTube, using the icon on the software interface.
- Streaming video—When you open your instant message program, YouCam displays a floating toolbar that lets you add graphic effects.
- Special effects—Add frames, filters, and emoticons to your snapshots and video.
- Snapshots—Take single frame or "burst" webcam snapshots in rapid succession.
- Connect—E-mail photos and video using the icon on the software interface.

 **NOTE:** For information about using software designed for use with the integrated camera, refer to the online Help for that software.

The camera light **(1)** turns on when video software accesses the camera **(2)**.

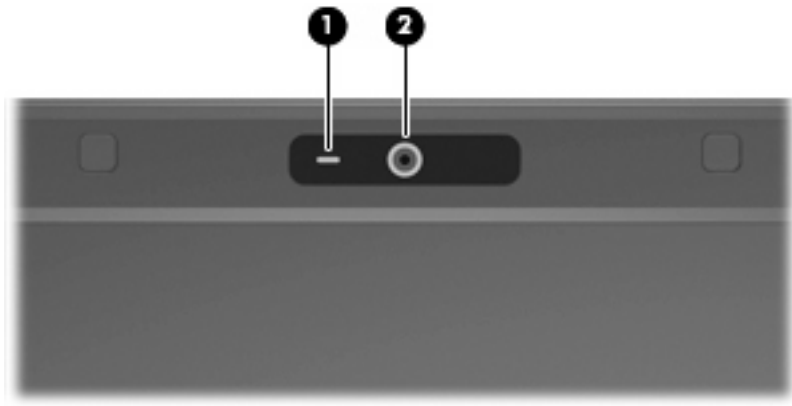

For optimum performance, observe the following guidelines while using the webcam:

- Be sure that you have the latest version of an instant message program before starting a video conversation.
- The webcam may not work properly across some network firewalls. If you are having trouble viewing or sending video to someone on another LAN or outside your network firewall, temporarily disable the firewall.

 **NOTE:** Under some circumstances a firewall can block access to Internet games, interfere with printer or file sharing on a network, or block authorized e-mail attachments. To temporarily solve the problem, disable the firewall, perform the task that you want to perform, and then reenable the firewall. To permanently resolve the problem, reconfigure the firewall.

- Whenever possible, place bright light sources behind the camera and out of the picture area.

Adjusting webcam properties

You can adjust the following webcam properties:

- **Brightness**—Controls the amount of light that is incorporated into the image. A higher brightness setting creates a brighter image; a lower brightness setting creates a darker image.
- **Contrast**—Controls the difference between lighter and darker areas on the image. A higher contrast setting intensifies the image; a lower contrast setting maintains more of the original information's dynamic range but leads to a flatter image.
- **Hue**—Controls the aspect of color that distinguishes it from another color (what makes a color red, green, or blue). Hue is distinct from saturation, which measures the intensity of the hue.
- **Saturation**—Controls the strength of color in the final image. A higher saturation setting creates a bolder image; a lower saturation setting creates a more subtle image.
- **Sharpness**—Controls the definition of edges in an image. A higher sharpness setting creates a more defined image; a lower sharpness setting creates a softer image.
- **Gamma**—Controls the contrast affecting the mid-level grays or midtones of an image. Adjusting the gamma of an image allows you to change the brightness values of the middle range of gray tones without dramatically altering the shadows and highlights. A lower gamma setting makes grays look black, and makes dark colors even darker.
- **Backlight Comp**—Compensates in cases where a subject with a large amount of background light would otherwise be obscured by blooming or silhouetting.

The Properties dialog box is accessible from various programs that use the integrated camera, usually from a configuration, settings, or properties menu.

Using an optical drive

Depending on the type of optical drive and software installed in your computer, the optical drive plays, copies, and creates CDs or DVDs.

Identifying the installed optical drive

- ▲ Select **Start > Computer**.

Inserting an optical disc (CD or DVD)

1. Turn on the computer.
2. Press the release button (1) on the drive bezel to release the disc tray.
3. Pull out the tray (2).
4. Hold the disc by the edges to avoid touching the flat surfaces and position the disc label-side up over the tray spindle.

 **NOTE:** If the tray is not fully accessible, tilt the disc carefully to position it over the spindle.

5. Gently press the disc (3) down onto the tray spindle until the disc snaps into place.

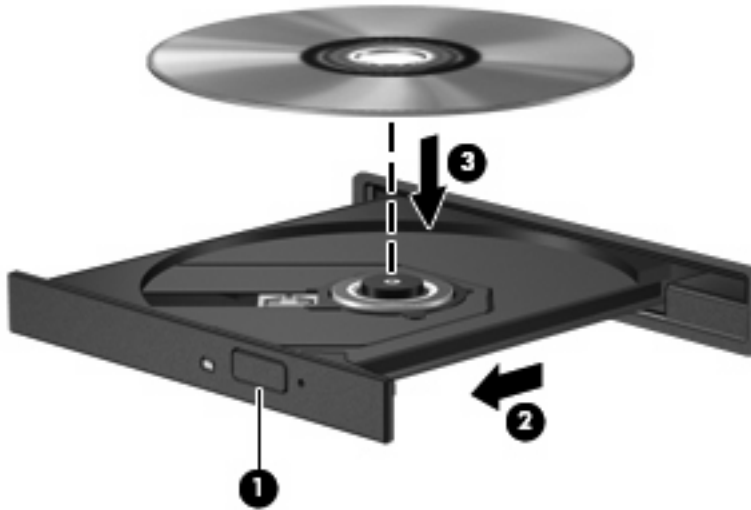

6. Close the disc tray.

 **NOTE:** After you insert a disc, a short pause is normal. If you have not selected a media player, an AutoPlay dialog box opens. It prompts you to select how you want to use the media content.

Removing an optical disc (CD or DVD)

There are 2 ways to remove a disc, depending on whether the disc tray opens normally or not.

When the disc tray opens

1. Press the release button **(1)** on the drive bezel to release the disc tray, and then gently pull out the tray **(2)** until it stops.
2. Remove the disc **(3)** from the tray by gently pressing down on the spindle while lifting the outer edges of the disc. Hold the disc by the edges and avoid touching the flat surfaces.

 **NOTE:** If the tray is not fully accessible, tilt the disc carefully as you remove it.

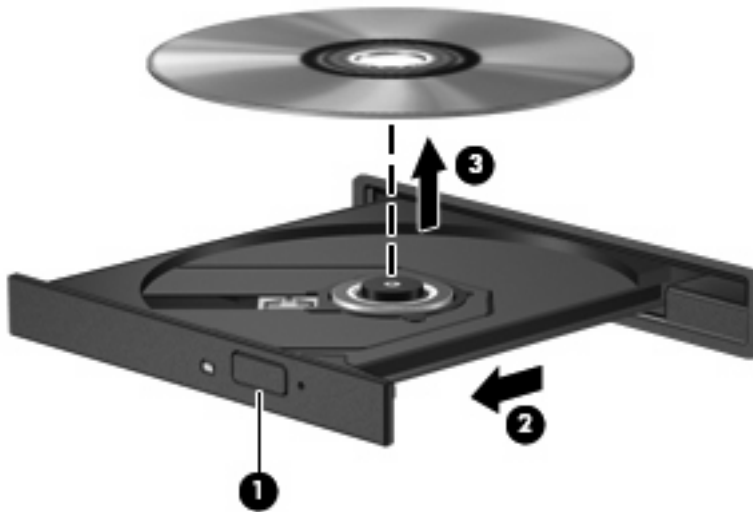

3. Close the disc tray and place the disc in a protective case.

When the disc tray does not open

1. Insert the end of a paper clip **(1)** into the release access in the front bezel of the drive.
2. Press in gently on the paper clip until the tray is released, and then pull out the tray **(2)** until it stops.

3. Remove the disc (3) from the tray by gently pressing down on the spindle while lifting the outer edges of the disc. Hold the disc by the edges and avoid touching the flat surfaces.

 **NOTE:** If the tray is not fully accessible, tilt the disc carefully as you remove it.

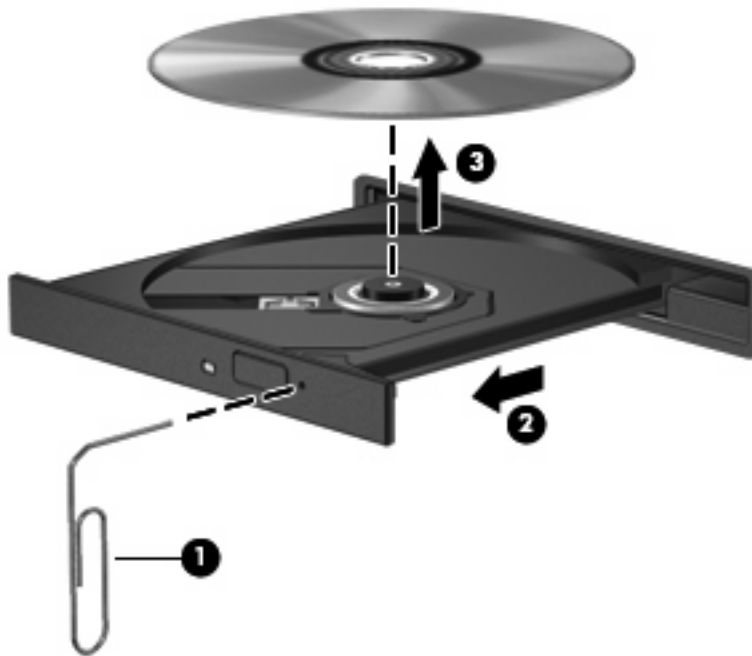

4. Close the disc tray and place the disc in a protective case.

Using the media activity hotkeys

A media activity hotkey is a combination of the **fn** key (1) and a function key.

- When an audio CD or a DVD is not playing, press **fn+f9** (2) to play the disc.
- When an audio CD or a DVD is playing, use the following hotkeys:
 - To pause or resume playing the disc, press **fn+f9** (2).
 - To stop the disc, press **fn+f10** (3).
 - To play the previous track of an audio CD or the previous chapter of a DVD, press **fn+f11** (4).
 - To play the next track of an audio CD or the next chapter of a DVD, press **fn+f12** (5).



2 Working with multimedia software

The computer includes preinstalled multimedia software. Some computer models also include additional multimedia software on an optical disc.

Depending on the hardware and software included with the computer, the following multimedia tasks may be supported:

- Playing digital media, including audio and video CDs, audio and video DVDs, and Internet radio
- Creating or copying data CDs
- Creating, editing, and burning audio CDs
- Creating, editing, and burning a video or movie to a DVD or video CD

△ **CAUTION:** To prevent loss of information or damage to a disc, observe the following guidelines:

Before writing to a disc, connect the computer to a reliable external power source. Do not write to a disc while the computer is running on battery power.

Before writing to a disc, close all open programs except the disc software you are using.

Do not copy directly from a source disc to a destination disc or from a network drive to a destination disc. Instead, copy from a source disc or network drive to your hard drive, and then copy from your hard drive to the destination disc.

Do not use the computer keyboard or move the computer while the computer is writing to a disc. The write process is sensitive to vibration.

 **NOTE:** For information about using software included with the computer, refer to the software manufacturer's instructions that may be provided on disc, as online Help files, or on the software manufacturer's Web site.

Opening preinstalled multimedia software

1. Select **Start > All Programs**.
2. Click the program that you want to open.

Installing multimedia software from a disc

1. Insert the disc into the optical drive.
2. When the installation wizard opens, follow the on-screen instructions.
3. Restart the computer if prompted to do so.

Using multimedia software

1. Select **Start > All Programs**, and then open the multimedia program you want to use. For example, if you want to use Windows Media Player to play an audio CD, click **Windows Media Player**.

 **NOTE:** Some programs may be located in subfolders.

2. Insert the media disc, such as an audio CD, into the optical drive.
3. Follow the instructions on the screen.

– or –

1. Insert the media disc, such as an audio CD, into the optical drive.
An AutoPlay dialog box opens.
2. Click a multimedia task from the list of tasks.

Preventing playback disruptions

To reduce the possibility of playback disruption:

- Save your work and close all open programs before playing a CD or a DVD.
- Do not connect or disconnect hardware while playing a disc.

Do not initiate Hibernation or Sleep while playing a disc. Otherwise, you may see a warning message asking if you want to continue. If this message is displayed, click **No**. After you click No, the computer may behave in either of the following ways:

- Playback may resume.
– or –
- The playback window in the multimedia program may close. To return to playing the CD or DVD, click the **Play** button in your multimedia program to restart the disc. In rare cases, you may need to exit the program and then restart it.

Changing DVD region settings

Most DVDs that contain copyrighted files also contain region codes. The region codes help protect copyrights internationally.

You can play a DVD containing a region code only if the region code on the DVD matches the region setting on your DVD drive.

△ **CAUTION:** The region settings on your DVD drive can be changed only 5 times.

The region setting you select the fifth time becomes the permanent region setting on the DVD drive.

The number of region changes remaining is displayed on the DVD Region tab.

To change settings through the operating system:

1. Select **Start > Computer > System properties**.
2. In the left pane, click **Device Manager**.

 **NOTE:** Windows includes the User Account Control feature to improve the security of your computer. You may be prompted for your permission or password for tasks such as installing applications, running utilities, or changing Windows settings. Refer to Windows online Help for more information.

3. Click the "+" sign next to **DVD/CD-ROM drives**.
4. Right-click the DVD drive for which you want to change region settings, and then click **Properties**.
5. Make the desired changes on the **DVD Region** tab.
6. Click **OK**.

Observing the copyright warning

It is a criminal offense, under applicable copyright laws, to make unauthorized copies of copyright-protected material, including computer programs, films, broadcasts, and sound recordings. Do not use this computer for such purposes.

Index

A

audio features 1
audio-in (microphone) jack 1, 2
audio-out (headphone) jack 1, 2

B

buttons
 volume mute 3

C

CD
 inserting 9
 playing 15
 protecting 13
 removing 10
 writing to 13
copyright warning 16

D

DVD
 changing region setting 16
 inserting 9
 playing 15
 protecting 13
 removing 10
 writing to 13
DVD region settings 16

E

external monitor port 4

H

hotkeys
 volume down 1
 volume mute 1
 volume up 1

I

internal microphone, identifying 1

J

jacks
 audio-in (microphone) 1, 2
 audio-out (headphone) 1, 2
 S-Video-out 5

M

media activity hotkeys 12
microphone, internal 1
microphones, supported 2
monitor, connecting 4
multimedia software
 described 13
 using 14
mute button 3
mute hotkey 1

O

optical disc
 inserting 9
 removing 10
 writing to 13
optical drive
 playing 15
 protecting 13

P

ports
 external monitor 4
programs
 multimedia 13
 using 14
projector, connecting 4
protecting playback 15

R

region codes, DVD 16

S

S-Video-out jack 5

software

 multimedia 13
 using 14
speakers 1

T

TV 2

V

VCR 2
volume down hotkey 1
volume mute button 3
volume mute hotkey 1
volume up hotkey 1
volume, adjusting 3

W

webcam
 identifying 6
 properties 8

