

HP Designjet 5100 printer
Customer Reference Guide



More Information

You can find more about the following topics on the *Using Your Printer CD*:

- Printing materials and their characteristics
- Animations of loading materials and installing ink supplies
- More about solving problems
- Page formatting
- Printer configuration and maintenance
- Functional specifications
- A glossary of terms and a comprehensive index

There is also more information available from the following sources:

- The WebAccess tool, for information about your printer status, technical support, on-line documentation, etc.
- HP Designjet Online (<http://www.designjet.hp.com>) for the latest product information, including on-line documentation and application notes for leading GIS software
- The setup instructions that came with your printer

Table of Contents

- 1. Use the front panel**
- 2. Load and unload material**
- 3. Maintain the ink system**
- 4. Manage the prints**
- 5. Front-panel messages**
- 6. Troubleshooting image quality**
- 7. Troubleshooting the ink supply**
- 8. Troubleshooting print material jams**
- 9. Legal and service information**



Use the front panel

7

- Functional areas 1-2
 - The navigation keys 1-2
 - Display screens 1-3
 - Action keys 1-4
 - Status lights 1-4
 - Sleep mode key 1-5
- Print mode selection 1-5
 - Selecting production mode 1-6
- Internal prints 1-7
 - Print the configuration 1-7
 - Menu print 1-7
- Front-panel menus 1-9
 - Setup menu: device setup 1-9
 - Setup menu: internal rip settings 1-12
 - Setup menu: queuing and nesting 1-12
 - Setup menu: page format 1-13
 - Setup menu: demos 1-14
 - Media menu 1-14
 - Ink cartridge menu 1-15
 - Printhead menu 1-15
- Navigation 1-15
 - Using the navigation keys 1-15
 - Entering the setup menu 1-16
- Navigation examples 1-17
 - Changing menu mode 1-17
 - Changing the page size 1-17
 - Changing the drying time 1-18
 - Restoring the default menu 1-19

Functional areas

The front panel of the printer is made up of the following functional areas, from left to right:

- Action keys and associated status lights
- A message display screen
- Navigation keys
- Sleep mode key and status light.

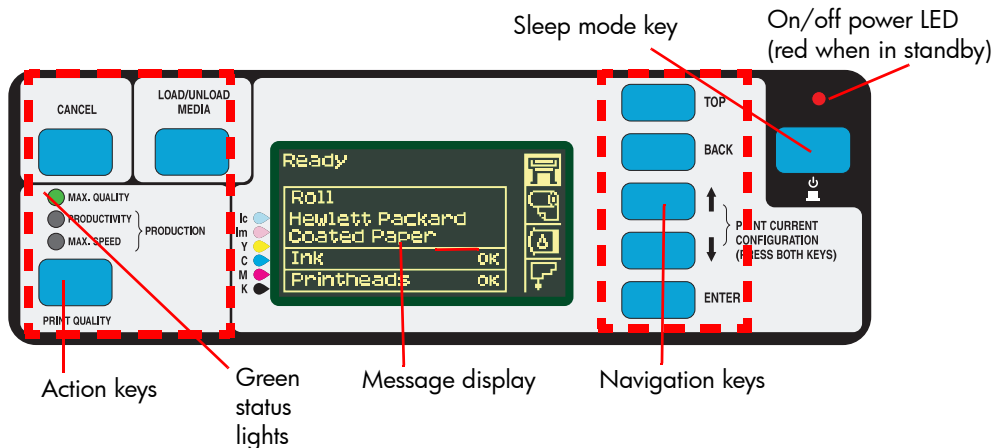

The navigation keys

The navigation keys are TOP, BACK, \uparrow , \downarrow and ENTER. They are located on the right-hand side of the front panel.

You use these keys to navigate through the menu system and to select menu icons and menus. See *Front-panel menus*, on page 9 and *Navigation*, on page 15.

You can also use the navigation keys to respond to messages. See 4, in section *front-panel messages* on the reverse of this guide, for detailed descriptions of error and status messages.

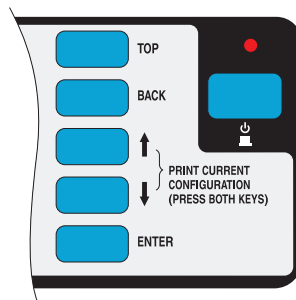

Display screens

The front panel can display a variety of information. When one of the four menus is highlighted, the front panel displays the following information:

Printer setup menu

If the Printer Setup menu is selected, there is a brief and overall description of the status of the consumable. If there is no printing material loaded, then there is a message describing the first step in loading material.

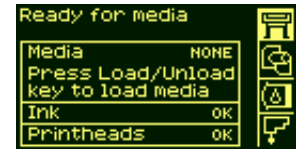

If you press **Enter** now, you will go to the Setup menu. See *Front-panel menus, on page 9*.

Media menu

If the Media menu is selected, and there is printing material loaded, the front panel displays information on the material you have loaded.



If you press **Enter** now, you will go to the Media menu, see *Media menu, on page 14*.

Ink cartridge icon

If the Ink Cartridge menu is selected, the status of each of the ink cartridges is shown. If there is a problem with one or more of the ink cartridges, the front panel will display an action message or a error code, see 4, in section *front-panel messages* on the reverse of this guide for more details.

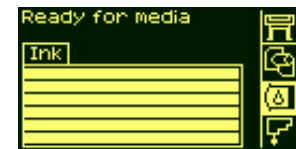

If you press **Enter** now, you will go to the Ink Cartridge menu, see *Ink cartridge menu, on page 15*.

Printhead icon

If the Printhead menu is selected, the front panel displays the status of each of the printheads. If there is a problem with one or more of the printheads, the front panel will display an action message or a error code see 4, in section *front-panel messages* on the reverse of this guide for more details.

If you press **Enter** now, you will go to the Printhead Menu, see *Printhead menu, on page 15*.



Menus

To configure the printer, use the menus to select and change the settings. Use the **↑** and **↓** keys to navigate and press the **Enter** key to select the options.

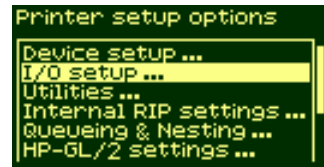

Procedure information

The front-panel display can help you through the various procedures you have to perform, such as loading printing material.



Action keys

The action portion of the front panel contains three buttons:

- **CANCEL** stops printing and printing material loading while they are in progress, cancels dry time, or cancels nest waiting. See *cancelling a page, on page 131*.
- **LOAD/UNLOAD** loads or unloads printing material. See *loading a roll into the printer, on page 34*.
- **PRINT QUALITY** selects the print mode, which may be Max Quality, Productivity, Production, or Max Speed. A green status light indicates the print mode you have selected. Two green lights indicate that you have selected Production mode (not available with all printing materials). See *Print mode selection, on page 5*.

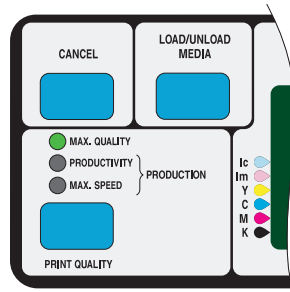

Status lights

The green status lights indicates what setting is currently active in the front

panel.

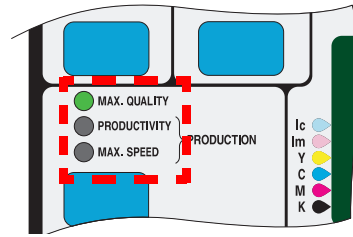

NOTE: In most cases, settings in your application software or printer driver will override the settings you make on the front panel of the printer.

Sleep mode key

After a period of inactivity, the printer goes into a sleep mode (low-power usage mode). This is indicated by the front-panel display and status indicators turning off. The indicator light on the front panel is on when the printer is in standby mode. The printer “wakes up” when you press the sleep mode key (or any other key) on the printer’s front panel, or when there is any I/O activity, such as the arrival of a printing job.

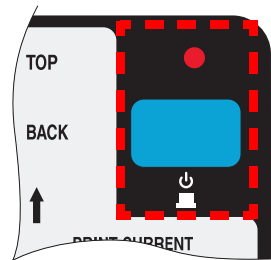

Print mode selection

- Choose **Max Speed** for the fastest printing. Ideal for checking prints, when image quality is not very important.
- Choose **Production** for fast printing with image quality good enough for some production purposes. Production mode is available only with certain paper types.
- Choose **Productivity** for a good combination of image quality and speed.
- Choose **Max Quality** for the highest possible image quality.

You can print images in different settings to see which gives the best combination of throughput and quality for your application. The resolution at which your print will be printed is summarized in the table below.

NOTE: To print in Max Quality mode with the Enhanced IQ setting, you must use glossy paper.

Print quality setting	Default resolution	Resolution with Enhanced IQ setting
Max Speed	300 × 300	

Print quality setting	Default resolution	Resolution with Enhanced IQ setting
Production	300 × 300	
Productivity	300 × 300	600 × 600
Max Quality	600 × 600	1200 × 600 (with glossy paper)

Selecting production mode

Production mode is a fast print mode that gives acceptable image quality for some purposes. It is available only with dye-based inks and certain specific HP paper types: Coated, Heavyweight Coated, Productivity Gloss, and Productivity Semi-Gloss. When one of these paper types is loaded, the front panel announces that Production mode is available.

If you select Production mode when using a printing material that does not support Production mode, the printer will print in Productivity mode.

If you decide to use a non-HP printing material, see *using non-hp printing materials*, on page 60.

Selecting production mode using the front panel

Press the Print Quality key repeatedly until you see two green lights, beside Productivity and Max Speed. The two lights indicate that Production mode is selected.

However, remember that the print mode selected in the front panel is ignored if you have set a different mode in the printer driver or in WebAccess.

Selecting production mode using the printer driver

To select Production mode in the Windows HP-GL/2 printer driver, you must select the Max Speed mode with the Enhanced IQ option.

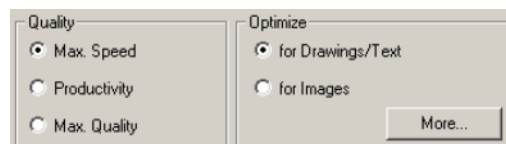

Click the More button above to obtain the Advanced Optimization Options box, below:

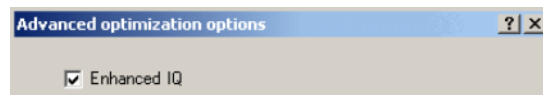

Selecting production mode using webaccess

Choose Submit Job and you will see a Print Quality option. Select

Production.

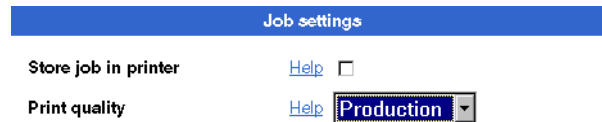

Internal prints

Print the configuration

To request a Current Configuration Print from the front panel:

- 1 Make sure that a roll or a sheet is loaded into the printer.
- 2 Press the **TOP** key to select the main menu on the front panel.
- 3 Make sure that the front panel displays the **Ready** message.
- 4 Press the **↑** and **↓** keys on the front panel simultaneously to print the Current Configuration Print.

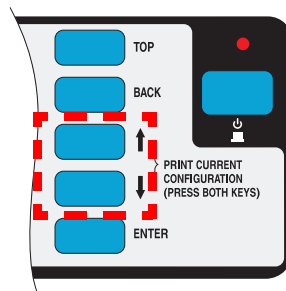
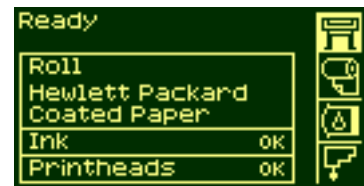

- 5 The front panel displays the message **Receiving** while the file is being processed, and then **Printing** as the printer starts printing.

Menu print

You can see the complete menu structure available on the printer by printing the Menu print. Alternatively, see *Front-panel menus, on page 9*. Use it to help you to navigate the menus.

NOTE: The Menu print is printed in the size specified in the Page Format → Size settings in the front panel. However, if a sheet is loaded, it will automatically shrink to fit. Make sure this setting specifies the size you want before printing.

- 1 Make sure that printing material is loaded.

- 2 Make sure the front panel displays the printer setup menu icon. If it does, press the **Top** key to select it. Press the **Enter** key.
- 3 The front panel will now display the printer setup options:
- 4 Press ↓ key until “Demos” is selected. Press the **Enter** key.
- 5 Press ↓ or ↑ key until “Menu” is displayed. Press the **Enter** key.
- 6 The front panel will now display the message “Receiving” while the file is being processed, and then the printer starts printing the Menu print.

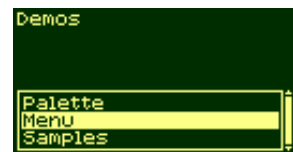
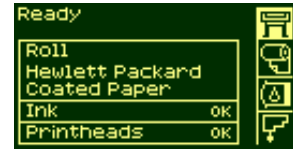

Other internal prints

Your printer can produce a number of other internal prints, as follows.

Service configuration print

The Service Configuration print provides information needed by service engineers, including the internal current configuration, operating conditions (temperature and humidity), ink levels, and other statistics about printer usage.

Network card configuration print

The Network Card Configuration Print shows the configuration of your network card.

Usage report

The Usage Report shows the status of the printer's usage counters. This information includes the total number of prints, number of prints per print mode, and total amount of ink used per color. The counts in this report are estimates.

Image quality print

The Image Quality Print can be used to help diagnose whether the printer has image quality problems, and if problems exist, help determine their cause. See 29, in section *image quality* on the reverse of this guide.

Palette print

The HP-GL/2 Palette Print shows the color or grayscale definitions in the

currently-selected color palette. See the 'Using Your Printer CD'.

Samples

These are prints showing the capabilities of the printer.

Front-panel menus

Key:

- 1 The items on a yellow background always appear on the Front Panel.
- 2 The items on a gray background appear in the front panel only when **Utilities > Menu mode** is set to **Full**. Full is the default.
- 3 The items on a blue background appear in the front panel only when the TUR is installed and loaded with a roll.
- 4 The items on a green background appear in the front panel only when the TUR is installed and not loaded with a roll, or when the TUR is not installed.

Setup menu: device setup

1st level	2nd level	3rd level
Accessories →	TUR installed →	Yes, No
	Other accessories →	Yes, No
Cutter →	On, Off	
Reduced margins →	On, Off	
Lang →	CALS/G4, HP-GL/2, TIFF, JPEG, Automatic	
Drying time →	Automatic	
	None	
Pen check →	Manual →	1 to 255 min
	Optimized	
Heater →	Manual →	every 1 to 255 plots
	Next plot	
	Automatic	
Sleep mode →	None	
	Manual →	10 to 100%
	30, 60, 120, 150, 180, 210, 240 min	

Setup menu: i/o setup

1st level	2nd level	3rd level
No I/O card found		
Card ID		
Card setup →	Configuration	
	Advanced →	Reset card
I/O timeout →	0.5 to 30 min	

Setup menu: utilities

1st level	2nd level	3rd level	4th level
Track media length →	Yes, No		
Usage →	Print usage, View usage		
Menu mode →	Short, Full		
Calibrations →	Printhead alignment		
	Accuracy →	Restore factory	
		Recalibrate →	Create pattern, Measure pattern
	Banding →	Restore factory	
		Recalibrate	
Reset WebAccess passwd			
Test prints →	HP-GL/2 config, Service config, Network card config, Usage report, Image quality print		
Statistics →	RAM present, Hard disk, Code rev, Service ID, Num cycles, Boot ROM		
Default menu			

Display contrast →	Up, Down	
Clean platen →	Automatic clean →	On, Off
	Clean now →	Automatic, Manual
Lens maintenance		

Setup menu: internal rip settings

1st level	2nd level	3rd level
Start printing →	Optimized, Immediately, After processing	
Ink emulation →	RGB →	Native, sRGB, Apple RGB, Adobe RGB, ColorMatch RGB
	CMYK →	Native, EuroScale, SWOP, Toyo, DIC, JMPA
Align calibration →	On, Off	
Black replacement →	Off, On	
Scale →	100 ... 419%, Fit to page	

Setup menu: queuing and nesting

1st level	2nd level	3rd level	4th level
Queue mgmt →	# ... →	Copies →	0 ... 99
		Move to top	
		Delete page	
Queue →	On, Off		
Nest →	Off		
	In order →	1 ... 99 min	

The Nest option appears only if Queue=On.

Setup menu: hp-gl/2 settings

1st level	2nd level	3rd level	4th level	5th level
Palette →	Software, Factory, Palette A, Palette B			
Define palette →	Palette A, Palette B →	Pen no. 0 to 15 →	Width →	0.13 to 12.0 mm
	Factory →	Pen no. 0 to 15 →	Width →	0 to 255
Merge →	On, Off			

Setup menu: page format

1st level	2nd level	3rd level
Size →	Inked area	1.0 × 1.4 m, 42 × 59 in, 44 × 62 in, 1.2 × 1.7 m, 52 × 73 in, 54 × 76 in, 60 × 100 in
	Extrawide →	60 × 100 in
	Oversize →	Over A2, Over A1
	Arch →	Best ARCH, ARCH A to E1
	JIS →	Best JIS B, JIS B4 to B1
	ANSI →	Best ANSI, ANSI A to E
	ISO →	Best ISO A, ISO A4 to A0
	Software	
Rotate →	0 to 270	
Margins →	Normal, Extended, Smaller	
Nest spacing →	Automatic	
	Manual →	0 to 30 mm
Mirroring →	On, Off	

Setup menu: demos

1st level

Samples
 Palette
 Menu

Media menu

1st level	2nd level	3rd level	4th level
Roll/sheet info →	Vendor name, Type of media, Width, Length, Max XY, Profile revision		
Media selection →	HP →	HW Coated, Coated Paper, Photo Imaging Gloss, Colorfast Vinyl, HP Adhesive-Backed Polypropylene, Paper Semi-Gloss, Poster Paper, Studio Canvas, More...	
	Others →	Coated, → HW Coated, Photo, Fine Arts, Vinyl/Film, Backlit, Textile, Colored, CAD, More...	Choose profile, Print sample
Delete media →	(list of downloaded media profiles; media profiles provided with the printer cannot be deleted)		
Move media			
TUR loaded →	Yes, No		
Form feed & cut →	Yes, No		

The front panel shows only a selection of the available printing materials.
 The Using Your Printer CD has a more complete list.
 See also *using non-hp printing materials*, on page 60.

Ink cartridge menu

1st level	2nd level
Light cyan cart info, → Light magenta cart info, Yellow cart info, Cyan cart info, Magenta cart info, Black cart info	HP 705 ink cartridge, Ink level, Capacity, Part number, Manufacture date
Replace ink cartridge →	Yes, No

Printhead menu

1st level	2nd level
Printhead info →	Light cyan info, Light magenta info, Yellow info, Cyan info, Magenta info, Black info
Recover printheads →	All printheads, Cyan, Magenta, Yellow, Black, Light C, Light M
Replace printheads →	Yes, No

Navigation

Using the navigation keys

Once in the first-level menu, you can navigate the menu system using the display keys.

Press the **Top key** to go back to the top (1st) level. This will bring you to the

setup menu icon See *Entering the setup menu, on page 16*.

Press the **Back** key to display the previous menu level, without changing any menu selections

Press \uparrow to scroll up, or \downarrow to scroll down through the menus.

Press the **Enter** key to:

- a** Select a menu and move to the next menu level, when in the menu system
- b** Change the printer's configuration to the highlighted menu item indicated with a \surd symbol.

The ... characters in a menu box indicate that another level of menu is available.

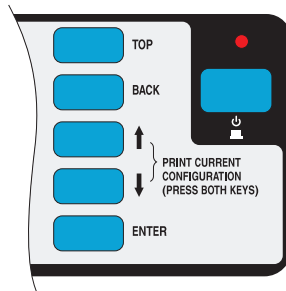

Entering the setup menu

- 1** Make sure the front panel displays the Printer Setup menu icon. If it does not, press the **Top** key.
- 2** Press the **Enter** key to enter the Printer Setup menu:

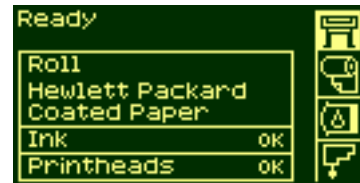

Note: If the short menu is selected, the I/O setup menu will not be available.

To see how to change from the full menu to the short menu, see *Navigation examples, on page 17*.

- 3** Now you are in the Printer Setup menu, you can change the settings of your printer.
- 4** To return to the top of the menu system, press the **Top** key.

Navigation examples

Changing menu mode

The front panel displays two types of menu. One is the short menu. This menu only contains the settings for everyday use of the printer. The other menu is the full menu mode which contains all of the menus.

- 1 Make sure the front panel displays the Printer Setup menu icon. If it does not, press the **Top** key. Then press the **Enter** key.
- 2 The front panel will now display the printer setup options:
- 3 Press the ↓ key until “Utilities” is selected. Press **Enter** key.
- 4 Press the ↓ key until “Menu mode” is selected. Press **Enter** key.
- 5 Use the ↑ or ↓ key to select the menu mode you want. The selected option will have a ✓ symbol.
- 6 To return to the top of the menu system, press the **Top** key.

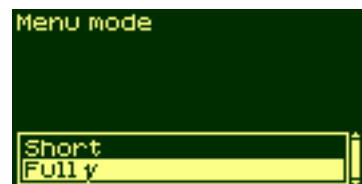
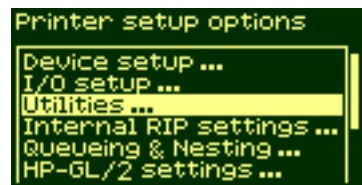
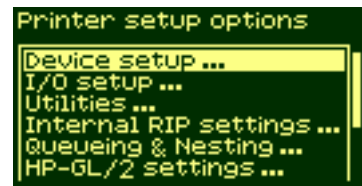
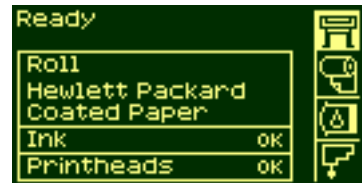

Changing the page size

This example shows how to adjust the page size.

- 1 Make sure the front panel displays the printer Setup Menu Icon. If it does not, press the **Top** key. Then Press the **Enter** key.

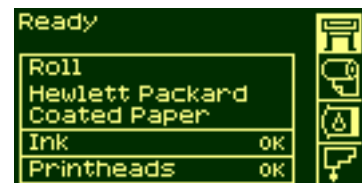

- 2 The front panel will now display the printer setup options:
- 3 Press the ↓ key until “Page Format” is selected. Press the **Enter** key.
- 4 The correct menu is already highlighted. Press the **Enter** key to select “Size=”.
- 5 Press the ↓ key until “Software” is selected. Press the **Enter** key.
- 6 ‘Software’ is now selected. The selection you have made will be indicated by the ✓ symbol.
- 7 To return to the top of the menu system, press the **Top** key.

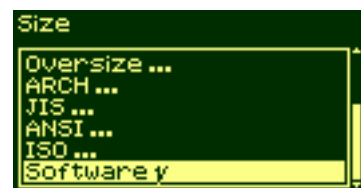
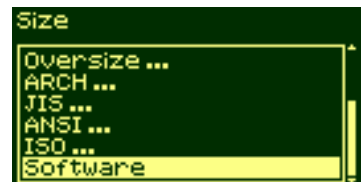
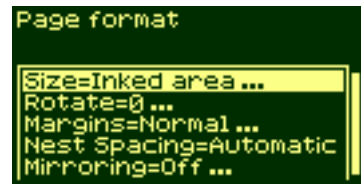
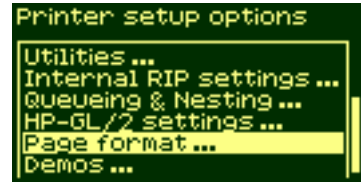
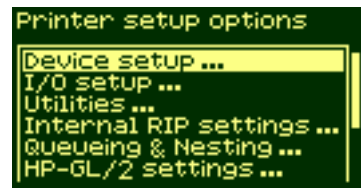

Changing the drying time

This example adjusts the drying time, a setting used to suit special printing conditions. See the ‘Using Your Printer CD’ for more details.

- 1 Make sure the front panel displays the Printer Setup menu icon. If it does not, press the **Top** key. Then press the **Enter** key.
- 2 The front panel will now display the printer setup options:

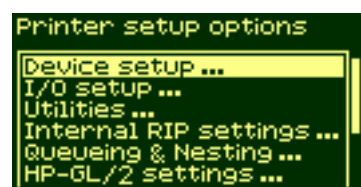
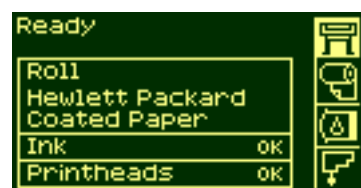

- 3 Press the ↓ key until the “Device setup” menu is selected. Press the **Enter** key.
- 4 Press the ↓ key until the “Drying time=” menu is selected. Press the **Enter** key.
- 5 Press the ↑ or ↓ key to select “Manual”.
- 6 Press the **Enter** key to select it as the setting for Drying time.
- 7 Press the ↑ or ↓ key to select the drying time.
- 8 To return to the top of the menu system, press the **Top** key.

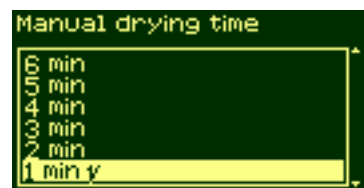
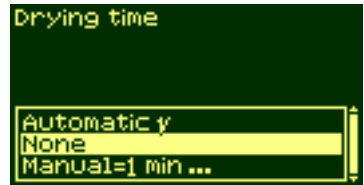
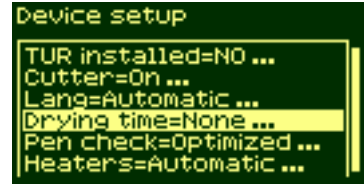
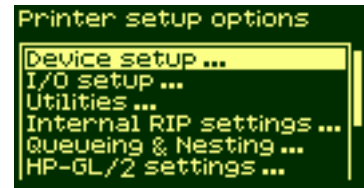

Restoring the default menu

If you are unsure about the settings you have made, or if you prefer to reset the printer’s default menu, go to the Utilities menu and select Default Menu.



Load and unload material

2

- Loading roll guidelines 2-2
 - Loading a roll into the printer 2-2
 - Using pre-loaded spindles 2-2
 - Attaching printing material to the take-up reel 2-2
 - Help with loading 2-3
- Loading a roll onto the spindle 2-3
- Loading a roll into the printer 2-5
- Attaching the roll to the take-up reel 2-9
- Unloading the roll from the take-up reel 2-12
- Removing the roll from the printer 2-15
- Loading sheets 2-16
- Unloading sheets 2-18
- Using non-hp printing materials 2-18
- Media length tracking 2-19

Loading roll guidelines

There are three steps to loading a roll into the printer.

- 1 Load the roll onto the spindle and install the loaded spindle into the printer.
- 2 Insert the roll into the printer and set the media type in the front panel.
- 3 Attach the roll to the take-up reel (if you have one).

CAUTION Long rolls are heavy. You may need two people to load them.

Loading a roll into the printer

In the initial stages of loading a roll you may want to open the window, but this is optional. If you are an experienced user for example, you can leave the window closed, thus saving time.

NOTE: Always start the procedure through the front panel.

When loading a roll into the printer:

- Check that the printing material is wound onto the spindle tightly.
- Check that the spindle is loaded correctly, with the guides installed firmly onto the spindle.
- If you are using a three-inch cardboard core, check that the core adaptors supplied with the printer have been installed. See below

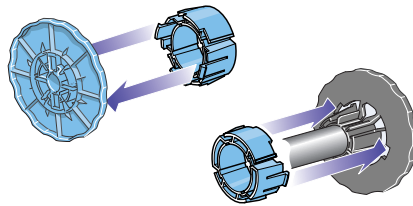

Using pre-loaded spindles

If you are a regular user of different printing materials, you can change your printing material more quickly if you have more than one spindle loaded with material. Extra spindles are available for purchase.

Attaching printing material to the take-up reel

When attaching printing material to the take-up reel:

- Check the leading edge as it unwinds from the spool. If it is not evenly cut or if it is skewed, trim the printing material.
- Check that the printing material is straight when it is attached to the take-up reel, otherwise it will skew as it is wound onto the core.
- The core tube on the take-up reel **must** be the same width as the printing material you are using.
- Make sure the take-up core is pushed firmly into both spindle guides.

- If you need to feed more printing material from the printer, and the 'Move Media' screen is no longer displayed, go to the Media menu and press **Enter**. Then select 'Move Media'.
- If you are using a three-inch cardboard core, make sure the core adaptors supplied with the printer have been installed.

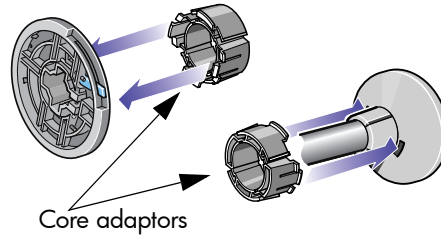

Help with loading

When loading printing material there is information available from:

- This *Pocket Guide*, installed at the back of the printer
- The labels located on the printer and on the spindles
- The front panel, which will guide you through the procedures step by step

Loading a roll onto the spindle

- 1 Make sure the printer wheels are locked (the brake lever is pressed down) to prevent the printer from moving.
- 2 Remove the empty spindle by pulling firmly on each end A and then B as indicated below.

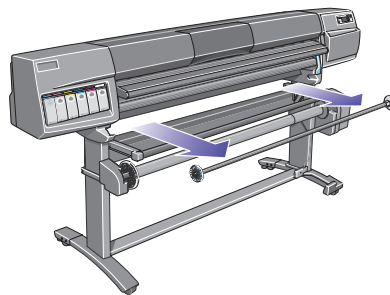

The spindle has a stop at each end to keep the roll in position. The stop at the left-hand end can be removed to mount a new roll, it slides along the

spindle to hold rolls of different widths.

- 3** Remove the removable stop (A) from the left-hand end of the spindle.

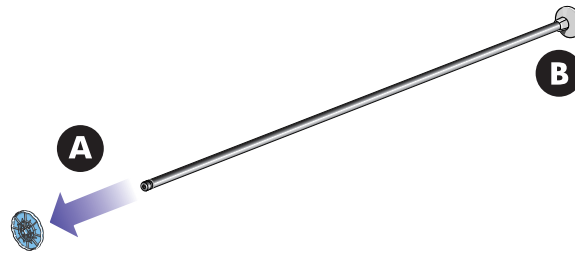

- 4** The roll may be very long; rest the spindle horizontally on a table and load the roll on the table. Bear in mind that you may need two people to handle it.
- 5** Slide the new roll onto the spindle. Make sure the printing material is oriented as shown. If it is not, remove the roll, turn it 180 degrees and slide it back on to the spindle.

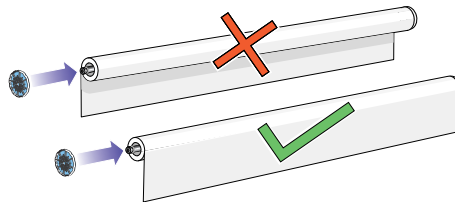

- 6** Put the removable stop on to the upper end of the spindle, and push it towards the end of the roll.

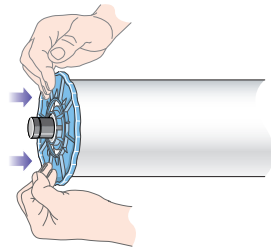

- 7** Ensure the spindle guide is pushed in as far as it will go, without using excessive force.

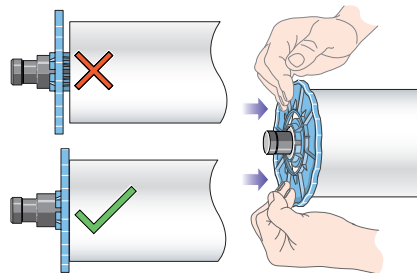

- 8** With the movable roll stop on the left, slide the spindle into the printer left and then right as shown by the arrows A and B.

- 9 The printing material should hang down from the roll exactly as shown below.

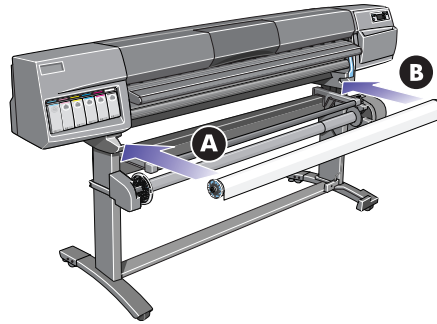

If you are a regular user of different printing materials, you can change rolls more quickly if you pre-load different materials on different spindles. Extra spindles are available for purchase.

Loading a roll into the printer

NOTE: To start this procedure you need to have a roll loaded on the spindle. See *Loading a roll onto the spindle, on page 3*.

NOTE: The following procedure assumes that you have the take-up reel installed and turned **On** in the Device Setup menu.

- 1 Check the leading edge as it unwinds from the spool. If it is not cut straight, continue with the next procedure. If the printing material is cut correctly, go to step 3.

WARNING



The knife used in the next step is sharp. Be sure the printer's wheels are locked. Keep fingers clear of the cutting path. Keep the knife away from children.

- 2 Trim the leading edge of the roll only if it is not straight. If the amount of printing material was printed at the end of the roll, this figure will be cut off if the material is trimmed.
 - a Pull the printing material over the top of the printer and lay it over the cutting track.
 - b Use the knife in the pocket located on the back of the printer to cut off the first few inches of the material.

- c Retract the blade and return the knife to its pocket.

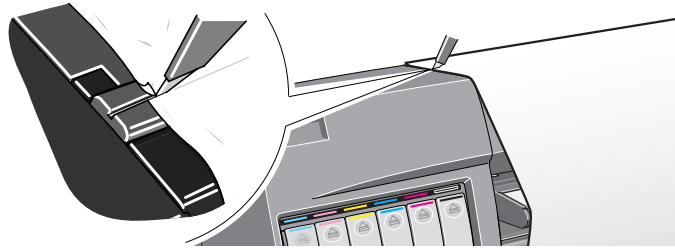

- 3 Press the **Top** button to select the main menu on the front panel.
- 4 Make sure that the front panel displays the **Ready for media** message. Shown alongside is an example of what the front panel will display with the main screen selected
- 5 Press the **LOAD/UNLOAD MEDIA** key on the front panel.

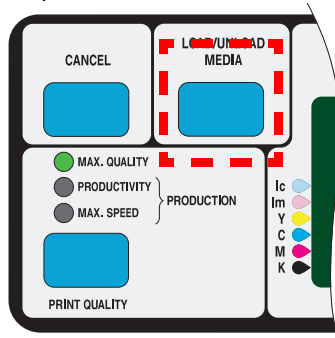

- 6 The front panel displays:
- 7 Select **Roll** and press **Enter**.
- 8 Open the window (optional).



NOTE: If you have loaded rolls before and you are an experienced user, you may want to leave the window down. Rolls can be loaded with the

window up or down.

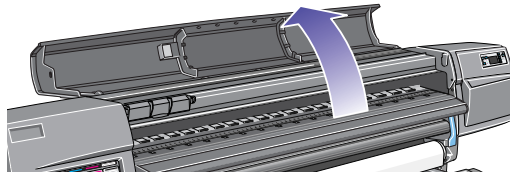

The front panel now displays:

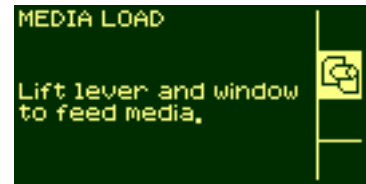

- 9** Lift the media load lever.

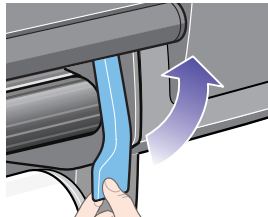

- 10** Pull out approximately 1 m (3 ft) of printing material.

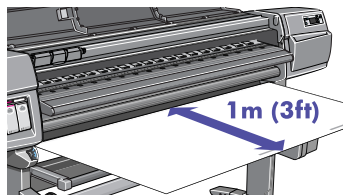

- 11** Carefully insert the printing material as shown below.

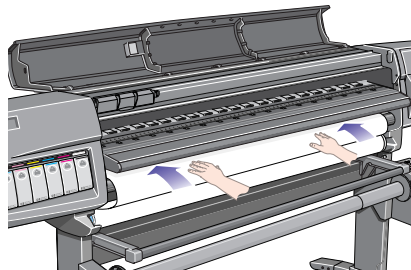

- 12** Continue inserting the material until it emerges from the printer as shown.

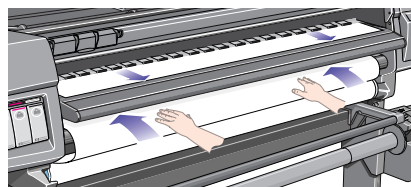

- 13** The front panel displays:
- 14** Take hold of the edges of the printing material now extending from the exit slot and pull the material toward you until taut. Then align the left and then the right edges of the material, so that they are aligned with the edges of the roll.

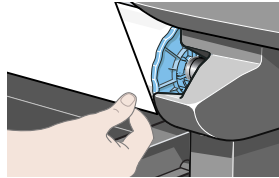

- 15** When the printing material is correctly aligned with the edges of the roll, lower the lever.

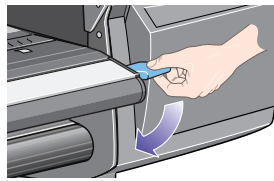

If the window is open, the front panel displays:

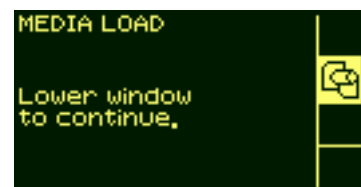

- 16** Lower the window.
- 17** The printer checks the alignment of the printing material.
- 18** If the printing material is correctly aligned, the printer will display:
- 19** Select "Yes" and press the **Enter** key.

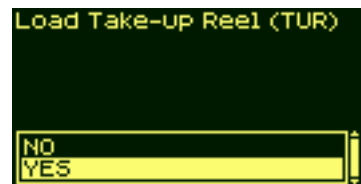

- 20** The front panel displays various vendors of printing materials if they have been downloaded. See the Using Your Printer CD for more details. Select the vendor of the material you are using. Press the **Enter** key.



- 21** The front panel displays various printing materials:

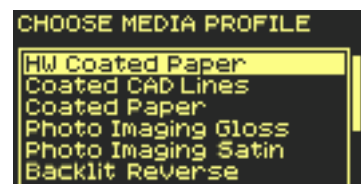

This list includes only a selection of the available printing materials. The Using Your Printer CD has a more complete list.

- 22 Select the printing material you are using and press the **Enter** key.
- 23 The front panel displays various lengths of material.



If you have been using the roll previously, it is unlikely to be a standard length of roll. The remaining length should be printed on the end of the roll (if you have not trimmed it). In this case select Custom Media.



- 24 Change the screen using the ↑ and ↓ keys to the amount printed on the end of the roll. Press the **Enter** key.

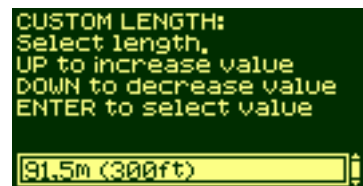

NOTE: To turn on and off the media length tracking function see *Media length tracking*, on page 19.

The printer is ready. You can now load the roll onto the take-up reel. Follow the procedure in the next section.



Attaching the roll to the take-up reel

The following procedure is applicable to your printer only if you have a take-up reel. If you do not have one, you can order it as an optional accessory; see the 'Using Your Printer CD'.

The first part of attaching a roll to the take-up reel is attaching the end of the roll (by tape) to the core tube supplied with the take-up reel. You can also use an empty cardboard tube to replace the plastic core tube. Both types of

core must be the same length as the roll you are using.

Plastic tube core

By matching color coded lengths of plastic tube, you can make a core tube for different roll sizes.

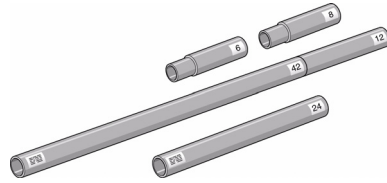

- 1 Use the ↓ key to move the leading edge of the printing material down until it is level with the centre of the core tube.

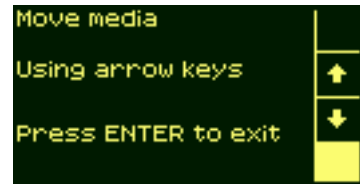

- 2 Make sure the printing material passes in front of the deflector, as shown.

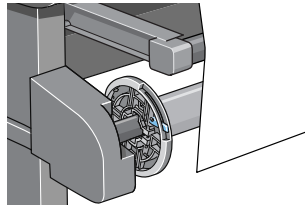

- 3 Move the adjustment levers on the left and right paper guides to the unlocked  position.

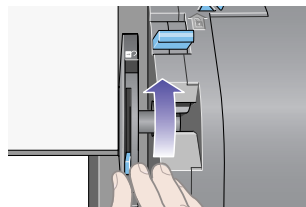

- 4 The two spindle guides and core must be positioned on the take-up reel spindle so that the roll is in the center, between the spindle guides. Adjust the position of the core as shown.

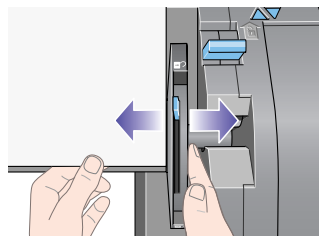

- 5 When you have adjusted the position of the core, pull the adjustment levers on both spindle guides to the locked  position.

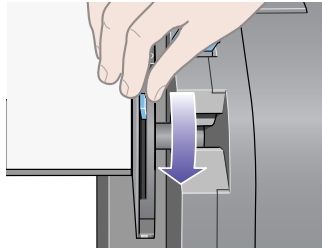

- 6 Pull the printing material taut to the position shown below. Do not attempt to pull more material out of the printer; if you need more, use the front panel. Use tape to secure the material to the core tube.

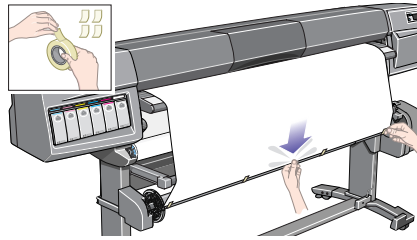

NOTE: To avoid the printing material skewing as it is wound onto the core tube, ensure it is straight when it is attached.

- 7 Press the ↓ key on the front panel to advance the printing material. Advance enough that the material can wrap at least once around the core.

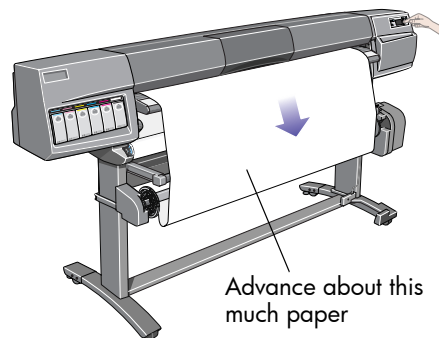

- 8 **Important:** Press the wind button on the take-up reel panel indicated below to wind the printing material once around the core.

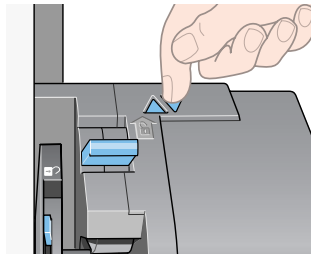

- 9 Press the ↓ button on the front panel again to advance some more material: enough to enable you to insert the media weight.

It is important that the media weight is the same width as the printing material you are using. By matching color coded lengths of plastic tube, you can make a media weight for different widths of standard paper sizes.

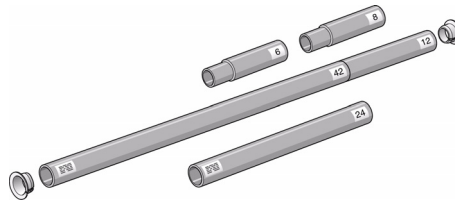

- 10** Carefully insert the media weight. Ensure that the end caps are installed and extend over the edges of the printing material.

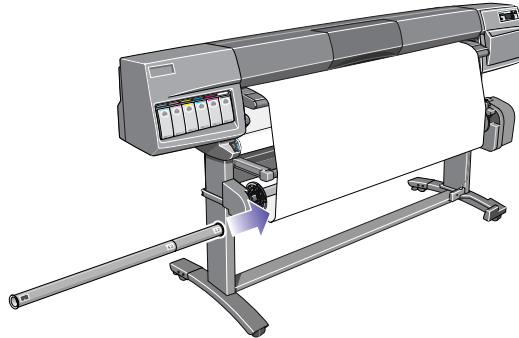

CAUTION It is important that the media weight is inserted. The take-up reel will not function properly without it.

- 11** Press **Enter** on the printer's front panel, which will then display the Ready message.

NOTE: When the take-up reel is in operation it is important to ensure that the take-up reel sensor is not blocked.

- 12** Shown below is how the printer will look when it is in operation. As printing material is fed from the printer, it drops down in a loop and up into the take-up reel spindle.

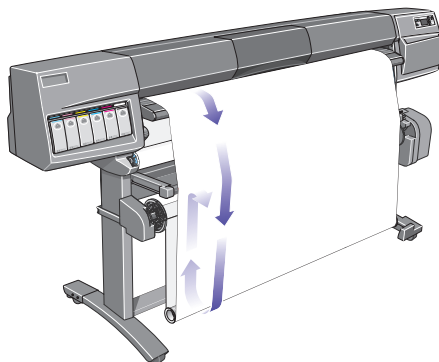

Unloading the roll from the take-up reel

To unload the roll from the take-up reel, perform the following procedure.

- 1** Ensure that the ink is dry.

2 Press the **LOAD/UNLOAD MEDIA** key on the front panel.

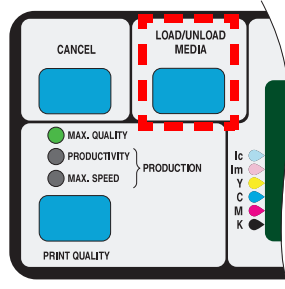

3 The front panel displays:



4 **Important:** Remove the media weight as shown below. It may help you to remove the end caps first.

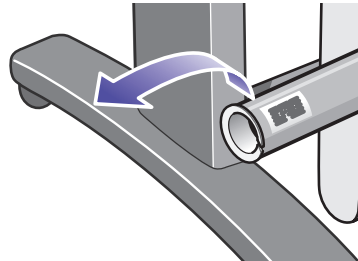

5 Press the wind button shown below to wind the printing material hanging down from the printer onto the take-up reel.

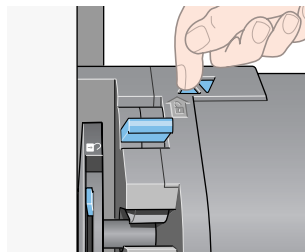

6 Press **Enter** on the printer's front panel. The printer will now cut the printing material.

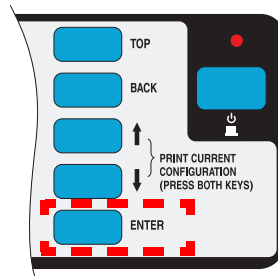

- 7** Press the wind button again.

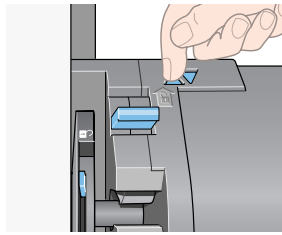

- 8** The printing material hanging down will be wound onto the core tube.

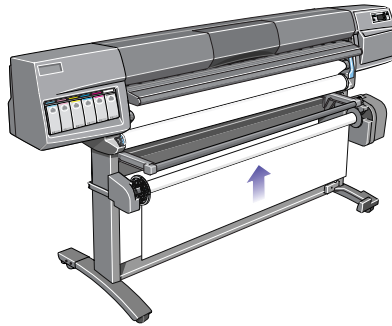

- 9** Slide open the spindle lock on the right-hand side of the take-up reel.

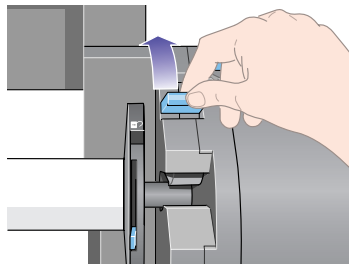

- 10** Remove the take-up reel spindle.

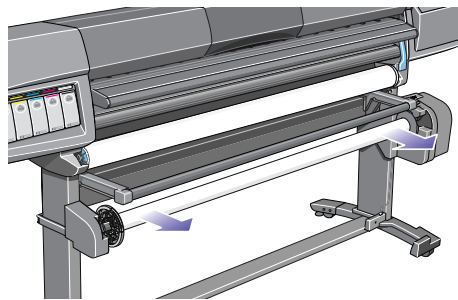

- 11** Unlock and remove the left-hand spindle guide from the take-up reel spindle.

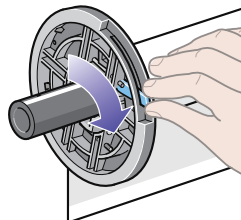

- 12** Remove the core tube from the spindle.

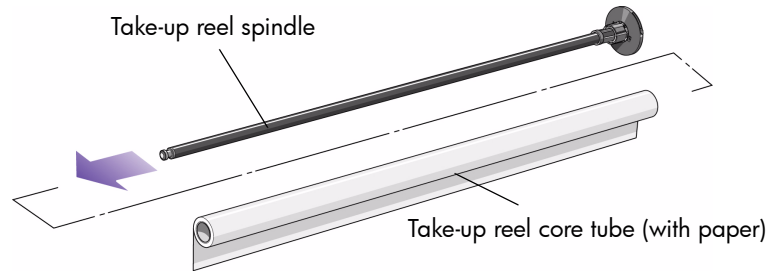

Removing the roll from the printer

- 1** Press the Load/Unload Media key on the front panel.

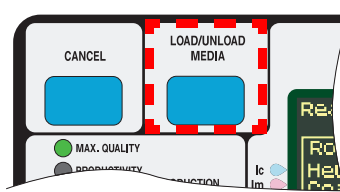

NOTE: If the media length tracking feature is switched on, the printer will print how much printing material you have remaining on the roll.

- 2** The printing material will be removed from the printer.
- 3** Turn the blue media stop by hand, until the printing material is fully removed from inside the printer.

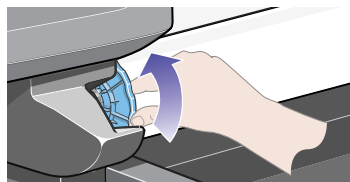
- 4** Press the **Enter** key.
- 5** Remove the roll from the printer by pulling on the roll as indicated by the arrows.

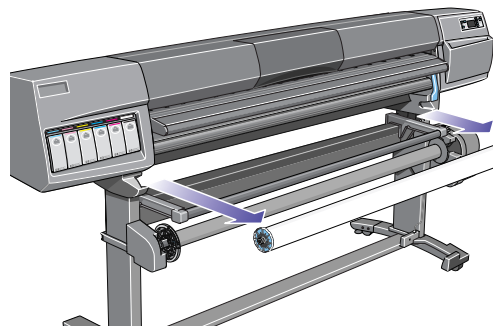

Loading sheets

NOTE: Any loaded roll must be removed from the printer before you can proceed with this procedure.

- 1 Make sure that the front panel displays the 'Ready for media' message. Shown here is an example of what the front panel will display with the main screen selected.
- 2 Press the **Load/Unload** key on the front panel.

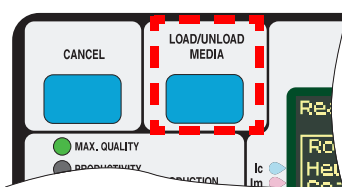

- 3 The front panel displays:
- 4 Select Sheet and press **Enter**.



- 5 The front panel now displays:

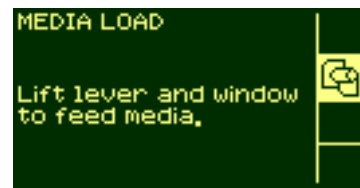

- 6 Lift the media load lever.

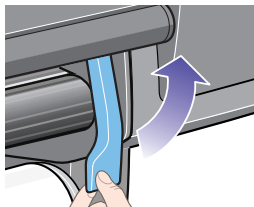

- 7 The front panel now displays:

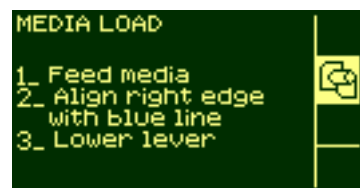

- 8 Insert the sheet into the printer as shown.

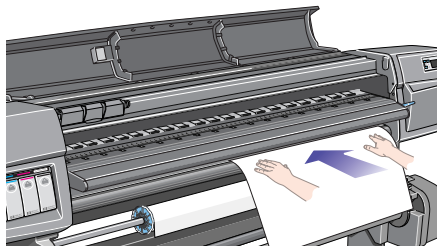

- 9** Insert the sheet until it reappears from the printer as shown below.

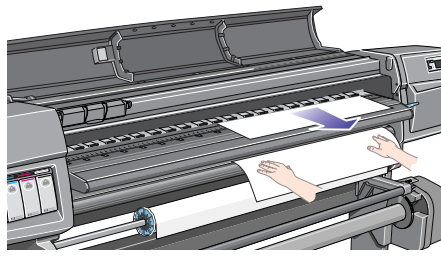

- 10** Pull the sheet out from the top.

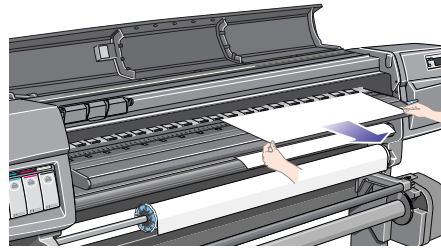

- 11** Align the sheet with the line as shown below.

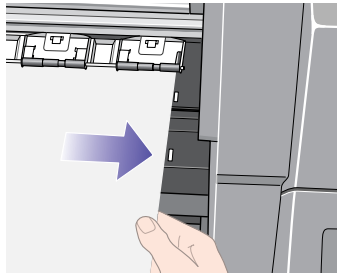

- 12** Lower the media load lever.

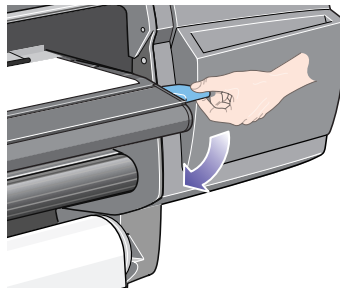

- 13** The front panel will display the following message if the window is open:

- 14** Lower the window.



- 15 The front panel displays various vendors of printing materials. Select the vendor of the material you are using. Press the **Enter** key.
- 16 The front panel displays various printing materials:
- 17 This list includes only a selection of the available printing materials. The Using Your Printer CD has a more complete list.
- 18 Select the material you are using and press the **Enter** key.
- 19 The front panel will now display "Ready", and you can begin to print.

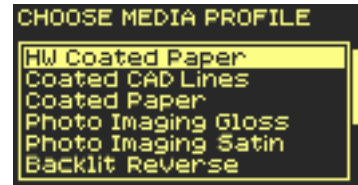

Unloading sheets

To unload a single sheet from the printer, press the **Load/Unload Media** key located on the front panel.

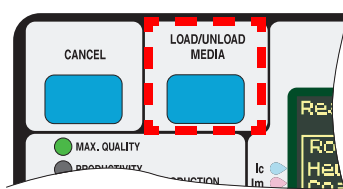

To give the ink time to dry, the printer holds the sheet for some time. (Refer to Drying Time in the 'Using Your Printer' CD.)

Using non-hp printing materials

During the loading process, the front panel will ask you to select the vendor of your printing material. In the Media Selection menu, you can choose HP or Others.

HP

If you choose HP, you will be shown a list of printing materials. Whichever you select, a media profile is already available to define to the printer the precise characteristics of the material.

Others

If you choose Others, you are offered a selection of generic media profiles. Choose the profile that seems closest to the characteristics of your non-HP printing material.

After choosing a media profile, you have the option of printing a sample

using that profile. It takes about nine minutes to print a sample, depending on the print mode and the printing material.

RGB sample

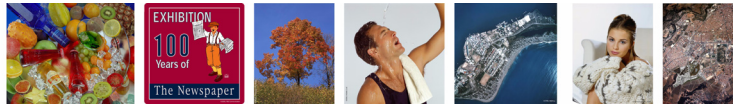

CMYK sample



If you are unsure which profile to choose, you can print samples using several different profiles and decide for yourself which gives the best print quality.

Many of our customers prefer high-grammage printing materials (about 170 g/m²), and there is a generic media profile best suited to such materials. Choose Heavyweight Coated, and then HW Coated 2. This profile is designed to give particularly good quality, especially in Production mode.

In some cases it may be possible to select Production mode although the non-HP printing material is not compatible with Production mode. In such cases the printer will print in Productivity mode.

Media length tracking

The media length tracking function enables the printer to register through the front panel how much printing material is left on the roll you are using.

To turn on the function

- 1 Go to the Printer Setup menu and press **Enter**:

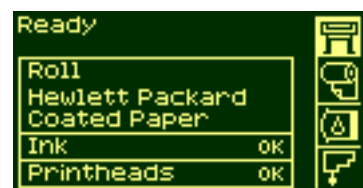

- 2 The front panel displays:

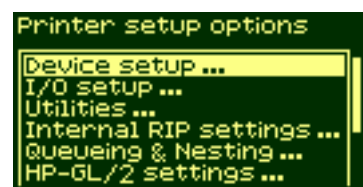

3 Select "Utilities".

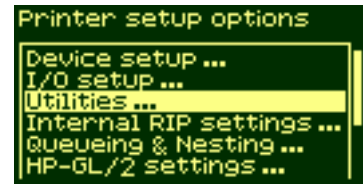

4 Press the **Enter** key. The front panel displays:

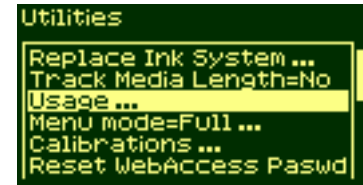

5 Select "Media length tracking". Press the **Enter** key.



6 The front panel displays:



7 Select Yes and press the **Enter** key. The front panel displays:



8 Press the **Top** key to return to the main menu.



Maintain the ink system

3

Ink cartridge statistics 3-2
Ink cartridge removal 3-2
Ink cartridge installation 3-3
Printhead statistics 3-4
Printhead removal 3-5
Printhead installation 3-8
Printhead cleaner removal 3-9
Printhead cleaner installation 3-11
After replacing a printhead and printhead cleaner 3-12

Ink cartridge statistics

Use the following procedure to get ink cartridge information:

- 1 Select the Ink Cartridge menu icon. Press the **Enter** key.

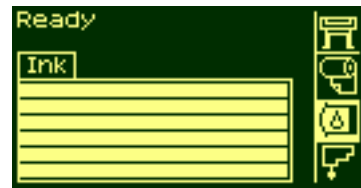

- 2 The front panel displays "Ink information". Press the Enter key.



- 3 The front panel displays:

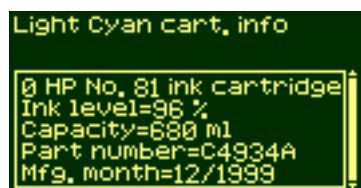

The information supplied is:

- The make of the ink cartridge (HP 705 is recommended)
- The percentage of ink remaining in the cartridge
- The original capacity of the ink cartridge in milliliters
- The re-order part number of the ink cartridge
- The month and year that the ink cartridge was manufactured

Ink cartridge removal

CAUTION

Remove an ink cartridge only if you are replacing it.

WARNING



Make sure the printer wheels are locked (the brake lever is pressed down) to prevent the printer from moving.

There are two types of ink cartridge removal.

- The ink cartridge is very low and you want to replace the ink cartridge with a full one for unattended printing, with the view to replacing it again and using until empty.
- The ink cartridge is empty and the front panel tells you to replace the ink cartridge.



- 1 Select the Ink Cartridges menu and press **Enter**.



2 The front panel displays:

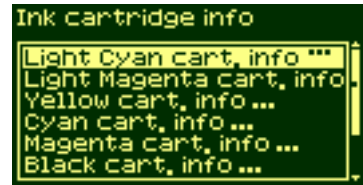

3 Press the ↑ and ↓ keys until “Replace Ink cartridge” is selected. Press **Enter**.

4 Remove the ink cartridge of the corresponding color by pushing the dimpled recess in the ink cartridge inward and upward, as indicated by the arrow shown below.



5 This releases the ink cartridge; you can then pull it out horizontally.



NOTE: Avoid touching the end of the ink cartridge that is inserted into the printer, as there may be ink on the connection.

Ink cartridge installation

NOTE: Each ink cartridge slot has a colored label above it. This should match the colored label on the new ink cartridge.

1 Pick up the new ink cartridge and find the label identifying the ink color. Hold the ink cartridge so that you can see the identifying colored label at the top of the side facing you.

- 2 Insert the ink cartridge into the ink cartridge slot labelled with the same color.



Color identifier at the top of the ink cartridge

NOTE: The ink cartridge is designed to prevent you from inserting the wrong ink type or into the wrong color slot. If you have difficulty inserting the ink cartridge, do not attempt to force it. Check again that the color of the ink cartridge matches the color of the ink cartridge slot, also that the colored marker is at the top of the ink cartridge.

- 3 Slide the ink cartridge into the slot until you feel some resistance, then stop.
- 4 Press firmly using the dimpled recess on the front of the ink cartridge, inwards and then downwards, as indicated by the arrow shown below, until the ink cartridge clicks into place.



- 5 The front panel displays:
- 6 Press the **Enter** key to continue.

```
Ink cart. access
HP Ink cartridges
successfully installed
Press ENTER to continue
```

NOTE: Avoid storing partially used ink cartridges on their ends.

Printhead statistics

- 1 To get information on your printheads, press the **Top** key on the front panel to go to the top of the menu system.

```
Ready
Roll
Hewlett Packard
Coated Paper
Ink OK
Printheads OK
```

- 2 Press the ↑ or ↓ key until the front panel displays the printhead menu icon. Press the **Enter** key.
- 3 Press the ↑ or ↓ key until the front panel highlights 'Printhead info ...'. Press the **Enter** key.
- 4 Press the ↑ or ↓ key until the front panel highlights the color that you want to see information on. Press the **Enter** key.
- 5 The front panel displays information on the selected printhead.

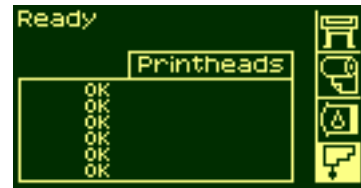

The information supplied is:

- The status of the printhead warranty
- The make of the printheads (HP 705 is recommended)
- The current status of the printhead
- The re-order part number of the printhead
- The time that the printhead has been operating in the printer
- How much ink has been consumed by the printhead
- The year and the month that the printhead was manufactured

Printhead removal

WARNING



Make sure the printer wheels are locked (the brake lever is pressed down) to prevent the printer from moving.

Printhead replacement must be performed with the printer switched on at the power isolation switch.

- 1 Select the Printhead menu on the front panel by using the ↑ and ↓ keys, and then press the **ENTER** key.



- 2 Select the "Replace printhead" option by using the ↑ and ↓ keys, and then press the **ENTER** key.



- 3 The printer moves the carriage into the correct position. When this is finished the front panel displays:



- 4 Lift the window and locate the carriage assembly.

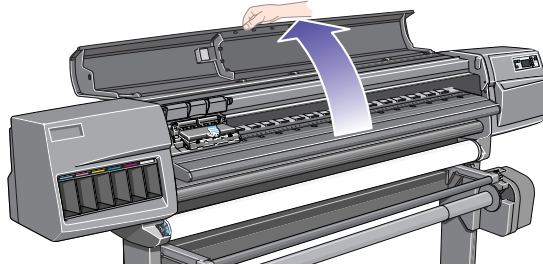

- 5 Lift the flap above the carriage assembly.

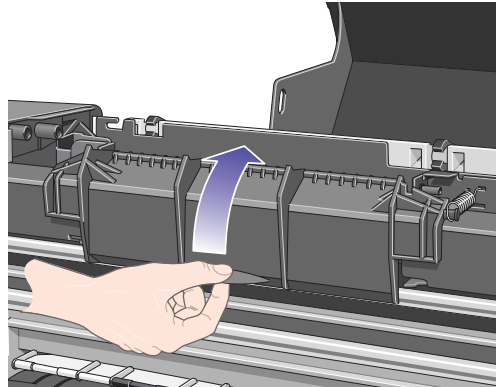

- 6 Pull up and release the latch on top of the carriage assembly.

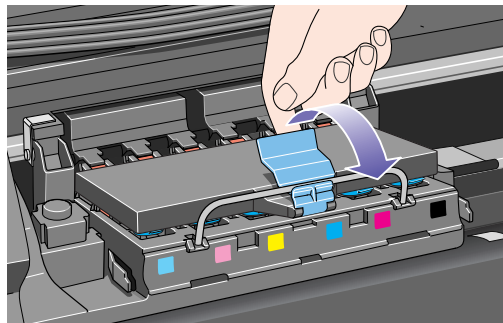

- 7** Lift up the cover. This will now give you access to the printheads.

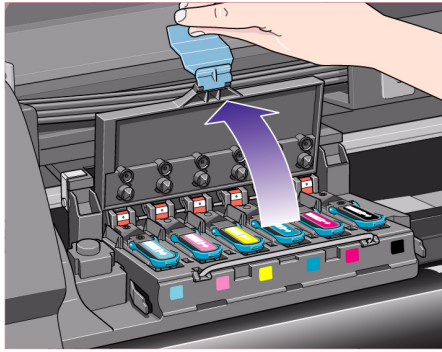

- 8** To remove a printhead, lift up the blue handle.

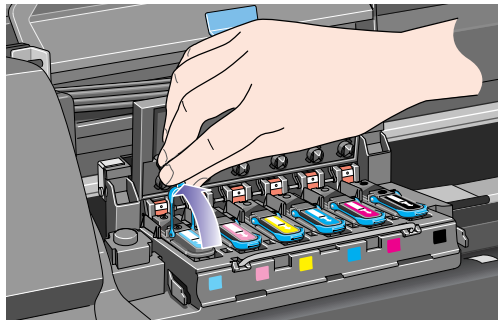

- 9** Place your index finger through the loop of the blue handle.

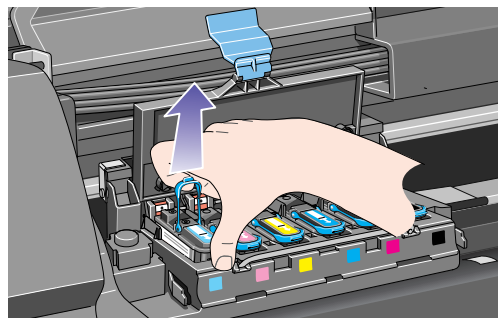

- 10** Gently pull the blue handle upward until the printhead is released from the carriage assembly.

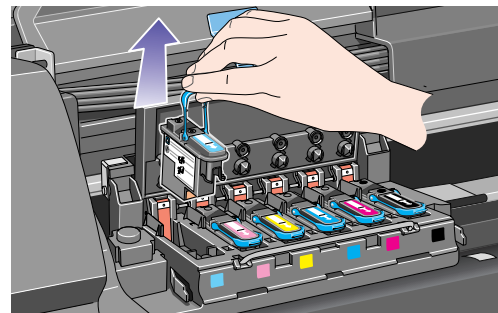

11 The front panel displays:



Printhead installation

- 1 If the printhead is new:
 - Remove the blue protective cap by pulling down on it.
 - Remove the clear protective tape from the printhead's nozzles by pulling on the paper tab.

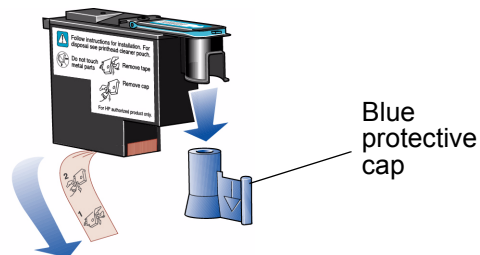

The printhead is designed to prevent you from accidentally inserting it into the wrong position. Check that the colored label on the printhead matches the colored label of the carriage assembly position into which the printhead is to be inserted.

- 2 Insert the new printhead into the correct carriage assembly position.

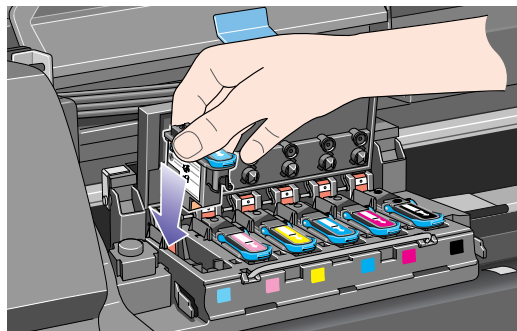

- 3 Push down as indicated by the arrow shown below.

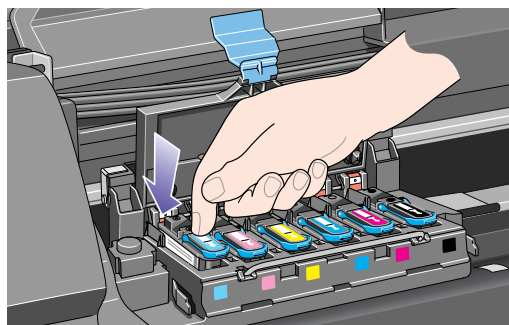

- 4 When installing the new printhead there may be some resistance, so you need to press it down firmly but smoothly.

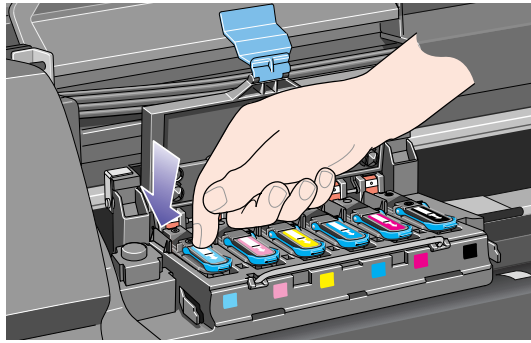

- 5 Insert any other printheads that need to be installed, and close the carriage assembly cover. Only when **all** the printheads have been inserted correctly and accepted by the printer, will the printer “beep”.

NOTE: If the printer does not “beep” when you insert the printhead and the “Reseat” or “Failed” message appears on the front panel, the printhead may need to be reseated.

- 6 Close the flap over the carriage assembly.

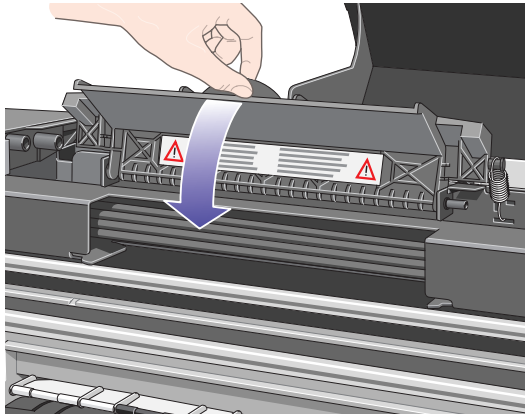

- 7 Close the window. The front panel displays:

- 8 Now replace the printhead cleaners for any printheads that have been changed. See the next page for details.



CAUTION Leaving the old printhead cleaner in the printer will shorten the new printhead’s life and possibly damage the printer.

Printhead cleaner removal

When removing the printhead cleaners:

- Be careful not to get ink on your hands. There may be ink on, around and inside the replaced printhead cleaner.

- Do not lay the replaced printhead cleaner on its side or turn it upside down, as ink may leak out.
- Always handle and store the replaced printhead cleaner upright to avoid spilling any ink.

WARNING



Make sure the printer wheels are locked (the brake lever is pressed down) to prevent the printer from moving.

- 1 After you have replaced a printhead, the front panel will prompt you to replace the printhead cleaner.
- 2 The printhead cleaners are located in slots underneath the front panel, at the front of the printer.

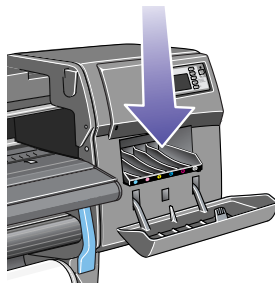

- 3 Open the service station door to access the printhead cleaners.

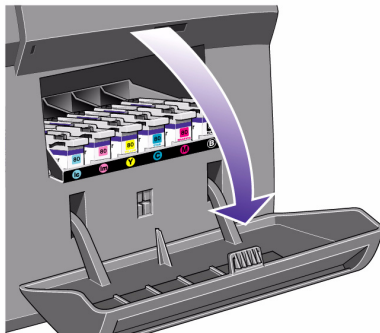

- 4 When the door has been opened the front panel displays:



- 5 Each printhead cleaner has a handle on the front. To remove, press inward and upward as indicated by the arrow shown here, until the printhead cleaner is released.

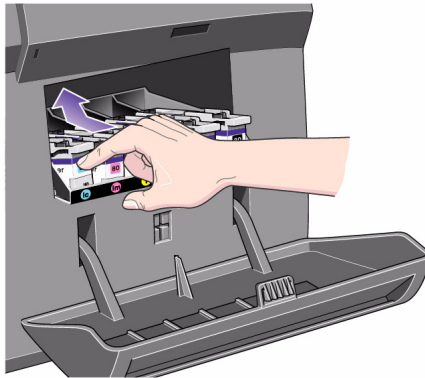

- 6 Lift the printhead cleaner up to remove it from the slots and slide the printhead cleaner out horizontally as shown below.

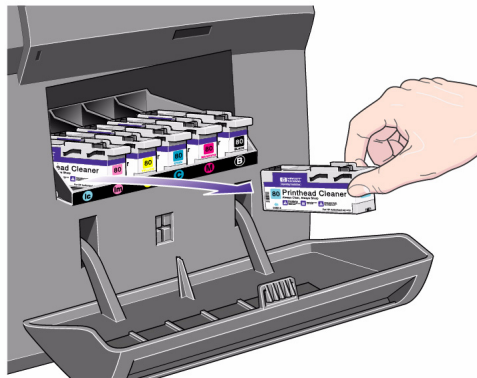

CAUTION

When replacing a printhead, always replace the corresponding printhead cleaner. Leaving the old printhead cleaner in the printer will seriously shorten the new printhead's life and possibly damage the printer.

Printhead cleaner installation

The plastic bag in which the new printhead cleaner comes can be used to dispose of the old printhead and printhead cleaner.

- 1 Insert each printhead cleaner into the correct color slot location, in the

service station, in the direction indicated by the arrow shown here.

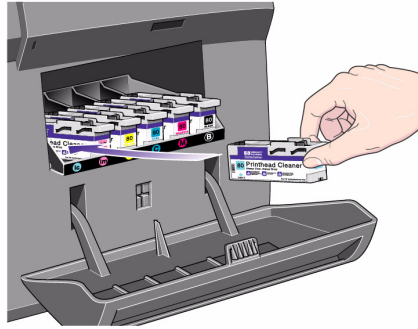

- 2** When the printhead cleaner has been pushed all the way in, press inwards and downwards as indicated by the arrow shown here, until it clicks into place. The front panel will not register the new printhead cleaner until the right-hand door is closed.

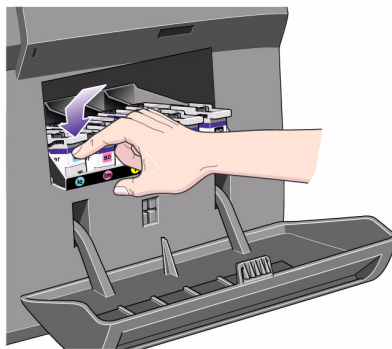

- 3** When you have inserted the printhead cleaner(s) into the printer, close the door.

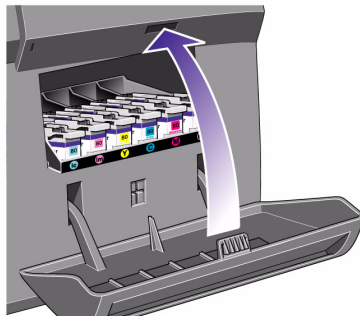

NOTE: The printer needs all the ink cartridges, printheads, and printhead cleaners to be installed before it can continue.

- 4** If no printing material is loaded, the front panel will instruct you to load some.

After replacing a printhead and printhead cleaner

Whenever a printhead is replaced, the printer will normally perform a printhead alignment. If you wish, you can turn off this automatic alignment

from the front panel: select Internal RIP Settings > Align Calibration > Off.

The printhead alignment procedure requires an A1 or D-size paper size.

When the front panel displays Ready, you are ready to print.

NOTE: Make sure the printer window and the right-hand door are closed after you replace the supplies. The printer will not print while these are open.

Manage the prints

4

- WebAccess 4-2
 - Starting WebAccess 4-2
 - Using WebAccess 4-3
- Pages printing or drying 4-5
 - Cancelling a page 4-5
 - Cancelling the drying time 4-5
- Managing the queue 4-5
 - Jobs and pages 4-5
 - What is the queue? 4-5
 - The 'start printing' options 4-6
 - Starting to print a file that is waiting for a time-out 4-6
 - Identifying a job in the queue 4-6
 - Viewing the size of a page in the queue 4-7
 - Prioritizing a job in the queue 4-7
 - Deleting a job from the queue 4-7
 - Making copies of a job in the queue 4-8
- Nesting pages 4-9
 - What is nesting? 4-9
 - When does the printer try to nest pages? 4-9
 - Which pages qualify for nesting? 4-9
 - How long does the printer wait for another file? 4-9

WebAccess

WebAccess is the control centre for remote management of your printer. From any computer, you can use an ordinary Web browser to contact your printer's internal Web server, which gives you the following facilities:

- Detailed reports on the status and history of your printer and your printing jobs
- Cancel or hold printing jobs
- Send files directly to the printer
- Store jobs permanently in the printer for repeated printing
- Download firmware upgrades and media profiles
- Request e-mail alerts whenever an error condition occurs
- Access HP Instant Support to troubleshoot any problem you may have

For more details about WebAccess, refer to the 'Using Your Printer CD' or see the information available within WebAccess.

Starting WebAccess

Start your Web browser and give the address of your printer, as follows:

<http://IPaddress/>

where *IPaddress* is the IP address of the printer. You can find out the IP address of the printer from the front panel, as follows:

- 1** From the Printer Setup menu, select **IO setup**.
- 2** From **IO setup**, select **Card ID**.
- 3** Under **Card ID**, find the line starting with **IP=**. The remainder of that line is the IP address of the printer.

As an alternative to the IP address, you may give the DNS name of the printer. However, you will not be able to find the DNS name in the front panel; ask your network administrator if you would like to use it.

Each status display is static: it does not automatically update itself as time goes by. To update it, click on the Update icon.

Using WebAccess

This section provides examples of everyday tasks you might want to perform.

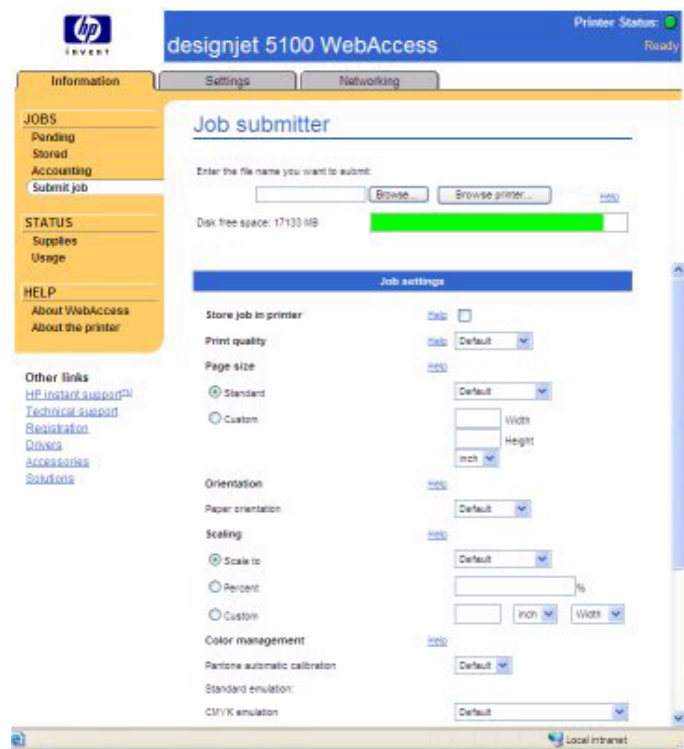

Submit a job

- 1 Open your browser.
- 2 Go to the Submit job page.
- 3 Browse your computer and select the file to print.
- 4 Set the job options.
- 5 Press the Print button.

Save a file in the permanent storage

- 1 Open your browser.
- 2 Go to the Submit job page.
- 3 Browse your computer and select the file to print.
- 4 In the job options, check the Store job in the printer option.
- 5 Set the the rest of the job options.
- 6 Press the Print button.

Print a file from the permanent storage

- 1 Open your browser.
- 2 Go to the Submit job page.
- 3 Press Browse printer and select the file to print.
- 4 Press the Print button in the Browse printer toolbar.
- 5 Set the the rest of the job options.
- 6 Press the Print button.

Check the ink and printing material usage for a job

- 1 Open your browser.
- 2 Go to the Accounting page.

The Accounting page shows you all the information regarding the jobs printed by the printer.

Check the status of the printer's supplies

- 1 Open your browser.
- 2 Go to the Supplies page.

The Supplies page shows you all the information regarding loaded printing material and ink levels.

Periodically track the usage of the printer

- 1 Open your browser.
- 2 Go to the Usage page.
- 3 Go to the Historical tab to see the accumulated usage of the printer since the first day.
- 4 Go to the Snapshot tab to save a record of the accumulated usage since the last snapshot, and reset the counters to zero.
- 5 Go to the Accumulated tab to view the accumulated usage since the last snapshot.

Pages printing or drying

RTL and HP-GL/2 jobs are single-page jobs. Where we talk about the print paper, the term page means a single output page.

Cancelling a page

- 1 Press **Cancel** on the front panel.

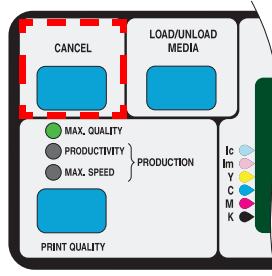

The printer advances the paper as though the print were finished.

Cancelling the drying time

Press the **Cancel** or **Enter** key on the front panel.

Managing the queue

The information included here only applies if you are using HP drivers.

Jobs and pages

When you look at the queue either from WebAccess or from the front panel, the queue is made up of individual 'jobs'. The jobs in a queue must not be confused with pages in the queue.

What is the queue?

Your printer can store pages in a queue at the same time as printing the current page. It stores them page by page. If you send only a single-page, you can regard these as files.

The length of the queue depends mainly on the jobs that you have in the queue, however as an approximation you can store about 30 jobs in A0/E-size in Max Quality mode. The queue stores processed output pages, not the input jobs.

If you wish, you can turn off the queue from the front panel: select Queuing

& Nesting > Queue > Off.

The 'start printing' options

You can select at what point you want to print the file you have in the printer's queue. Go to Internal RIP Settings > Start printing. There are three options you can select:

After processing

When this is selected the printer waits until the whole file has been processed and then it starts to print. This is the slowest setting but you can achieve the best image quality.

Immediately

This selection prints the file as it is processed. This is the quickest setting, however the printer may stop halfway through a print to process data. This setting is not recommended for complex images with dense color.

Optimized (default)

This setting calculates the best time to begin printing the file. It is the best mix between the After Processing and Immediately settings.

Starting to print a file that is waiting for a time-out

If all is in order (paper loaded, all ink components installed, and no file errors), there are still reasons why a file you have sent from your computer may not start printing when expected:

- The print file may lack a proper file terminator and the printer is therefore waiting for the specified I/O time-out period before assuming it is complete. See the Using Your Printer CD for more details.
- Nesting may be on and the printer is waiting for the specified nest wait time-out period before calculating the appropriate nests. In this case, the printer display shows the remaining time for the nesting time-out. See *How long does the printer wait for another file?*, on page 9.
- You may have "wait for preview" selected in your printer driver. This is a function you can use to check that the image is the one you want. You can check the preview in the WebAccess tool, then select "Start print".

Identifying a job in the queue

In Queueing & Nesting, you can scroll through the pages in the queue.

Each has an identifier, comprising:

<position in queue>: <image name>

Position in queue

The job currently being printed is in position 0. The next job to be printed is in position 1, the one after in position 2, etc.

The previous job printed is in position -1, the one before that in position -2, etc.

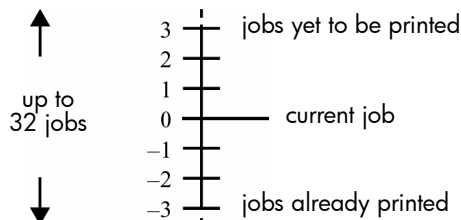

You can also check the queue in WebAccess where you will find more detailed information.

Viewing the size of a page in the queue

To view the size of any page in the queue, select it and choose Statistics.

Statistic	Comments
Width	The shorter side of the page, in millimeters.
Length	The longer side of the page, in millimeters.

Prioritizing a job in the queue

To make any job in the queue the next one to be printed, select it and choose *Move to top*.

If nesting is turned on, (see *What is nesting?*, on page 9) the prioritized job may still be nested with others. If you really want this job to be printed next, and on its own on the roll, then first turn nesting off and then use *Move to top* to move it the top of the queue.

Deleting a job from the queue

Under normal circumstances, there is no need to delete a job from the queue after printing it, as it will just “fall off the end” of the queue as more files are sent. However, if you have sent a file in error, and want to avoid any chance of it being reprinted, you can simply delete it, by selecting it and choosing *Delete*.

To remove a job that has not yet been printed, simply identify it by its position in the queue (see *Position in queue*, on page 7) and delete it, by

choosing Delete.

If the job is currently being printed (its queue position is 0), and you want both to cancel the job and to delete it, first press the **Cancel** key and then delete it from the queue.

Making copies of a job in the queue

Has the job already been printed?	Do you want one copy or several?	What to do
Yes	One	Use Move to top (see <i>Prioritizing a job in the queue, on page 7</i>).
	Several	Use Copies (see below) and then use Move to top (see <i>Prioritizing a job in the queue, on page 7</i>).
No	One	Use Copies (see below).
	Several	Use Copies (see below)

In all cases, the job must be still in the queue.

Having selected the job and chosen **Copies**, use the scrolling keys to specify the number of copies required, and press **Enter**. The number you enter is the actual number of pages to be printed; for example, choosing 2 for a page not yet printed means you will get the one original and one copy. The maximum is 99.

The setting you specify in this option overrides any value set by your software.

NOTE: If 'Rotate' was On when you sent the file, every copy will be rotated. See the 'Using Your Printer CD' for details on rotation.

Nesting pages

What is nesting?

Nesting means placing pages side-by-side on the paper (rather than one after the other), to avoid wasting paper.

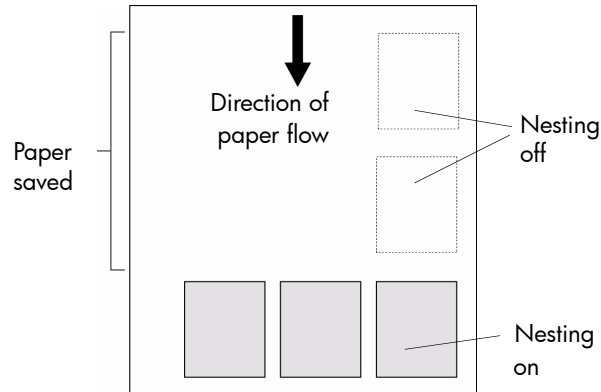

Refer to *Which pages qualify for nesting?*, on page 9.

When does the printer try to nest pages?

When all the following are true:

- The printer is loaded with roll paper not sheet paper.
- In the front-panel menus, Nest is ON.

Which pages qualify for nesting?

In order to be in the same nest, the individual pages must be compatible on the following criteria:

NOTE: Selecting Nesting On overrides the Start Printing settings.

- Color or grayscale. Either all are color or all are grayscale. Grayscale may include a color page rendered in gray scales; see the 'Using Your Printer CD' for more details.
- For HP-GL/2 only, margin sizes must be the same for all pages (normal, extended).
- The Mirror setting should be the same on all pages.
- The Rendering Intent must be the same.
- The Color Space must be the same.
- The Cutter setting must be the same.
- The Enhanced Resolution must be the same.

How long does the printer wait for another file?

So that the printer can make the best nest possible, it waits after a file has

been received to check whether a subsequent page will nest with it or with pages already in the queue. This waiting period is the nest wait time; the factory default nest wait time is two minutes. This means that the printer waits for up to two minutes after the last file is received before printing the final nest. You can change this waiting time using the front panel: Queuing & Nesting > Nest > In Order. The available range is 1 to 99 minutes.

While the printer is waiting for nesting to time out, it displays the remaining time in the front-panel display. You can print the nest (cancel the nest wait) by pressing the **Cancel** key.

Front-panel messages

5

Status code interpretation 5-2
 Consumable in warranty 5-2
 Status codes 5-2
Front-panel messages 5-3
Printhead status messages 5-10
Ink cartridge error messages 5-12
Printhead cleaner error messages 5-13
System error messages 5-13

Status code interpretation

The status code is a four-digit number that describes the status of the ink consumable.

After the status code there will be a brief action message. If this action message is performed the status should return to normal: that is, OK.



In the example shown here, one or more of the printheads have a replace message displayed. To find out which printhead has the error, select the printhead icon. You will see the status of all the printheads at once.

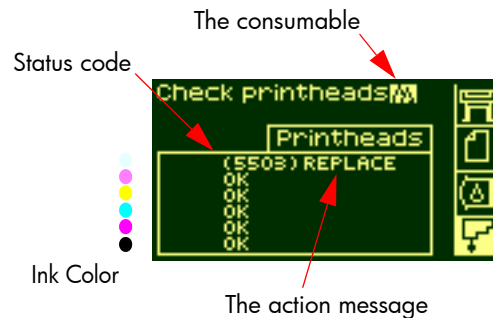

Consumable in warranty

If you have:

- performed the action specified in the message
- looked up the status codes, and performed the procedures described there

but the error has not been corrected, and your consumable is still IN WARRANTY, make a note of the whole status code and contact your support representative. To check whether it is in warranty refer to 71, in section *maintain the ink system* on the reverse of this guide.

For detailed warranty information, refer to the Legal Information document that came with your printer.

Status codes

The tables in *Printhead status messages*, on page 10, for example, show the status codes with messages such as 'replace' or 'reset' next to them. Perform the message action (replace, reset, etc.) first. If this does not solve the problem, refer to the status codes in the table and perform the relevant procedure(s).

Front-panel messages

Status	Description	Procedure
A factory media cannot be deleted.	You cannot delete this printing material because it is one of the standard materials that was added in the factory.	
Calibrate error	The calibration the printer was performing has failed.	Note down the calibration error code that comes with this message, and which calibration failed, and contact your support representative.
Calibration cancelled	The printer was performing a calibration and you pressed the CANCEL key on the front panel.	If the printer was performing a calibration to correct an internal error the correct functioning of the printer may be affected.
Calibration Error XXXX Press Enter to Continue	The printer was calibrating and failed to complete the calibration. The front panel shows an error code, represented here by XXXX.	Press Enter to continue. You can continue to print; but, if the printer was performing a calibration to correct an internal error, the correct functioning of the printer may be affected.
Cancelling firmware upgrade. Please wait.	You are downloading new firmware and the action has been canceled.	This may be because the firmware/software you are attempting to download is older than the version you already have, or the version is not compatible with your printer.
Delete media profile?	You are about to delete the profile that you have in the printer for a specific printing material.	
Edge not found. Reload media.	The internal sensor on the carriage cannot see the edge of the printing material. This may be because the material is 100% transparent or because the lens cover is dirty.	Try to load a different printing material. If the same message is displayed, replace the lens cover. See the "Using Your Printer" CD.
Full ink cartridges needed	The ink system startup must have full cartridges to enable the initialization of the complete ink system.	Remove the ink cartridges that are low on ink and replace with full ink cartridges.
Have ink tube replaced or risk printer damage Contact HP	The internal ink system tubes need replacing urgently.	The ink system tubes have reached the end of their useful life. Please replace them before they break and damage the printer.

Status	Description	Procedure
HP is not responsible for damage from use of non-HP ink Select YES to replace	Use genuine HP components for excellent image quality from your printer. If you choose to continue printing with this ink supply you may not have a properly functioning or reliable ink level indicator. The solid bar showing the ink level will be replaced by a patterned bar. You may not know when the ink supply is running low or empty. Printing with an empty ink supply may seriously damage your printhead, ink tubes, and printer. Any damage resulting from use of this supply or non-Hewlett-Packard ink is not covered under your printer warranty.	Select Yes to replace your cartridge with a genuine HP 705 cartridge, No to continue. See the "Using Your Printer CD".
Initializing printer Please wait. %	The printer needs about ten minutes to initialize the system completely.	You can put the printer into sleep mode, which will return to Ready status much quicker. See the 7, in section <i>use the front panel</i> on the reverse of this guide.
Ink drying, please wait	Printing has finished, but the ink still needs some time to dry.	To adjust the drying time settings, see the "Using Your Printer CD".
Ink tube maintenance advised	The internal ink system tubes need replacing.	The ink system tubes have reached the end of their useful life. Please replace them before they break and damage the printer.
Ink tube maintenance required now	The need to change the ink tubes may affect the performance of the printer.	The ink system tubes have reached the end of their useful life. Please replace them before they break and damage the printer.
Insert	There is no consumable installed.	Insert the correct printhead(s) into the carriage assembly. Check the interconnect to see if they need cleaning. See <i>carriage interconnect wiper</i> , on page 56.
Insert cleaner	The printhead cleaners are located on the right-hand side of the printer.	
Insert ink cartridges	This is an ink cartridge installation message.	See 67, in section <i>maintain the ink system</i> on the reverse of this guide.

Status	Description	Procedure
Insert printhead	This message is prompting you to insert a printhead into the carriage assembly.	See 77, in section <i>maintain the ink system</i> on the reverse of this guide.
Lift window to remove printheads	You have selected Replace Printhead and the front panel is guiding you through the procedure.	See 77, in section <i>maintain the ink system</i> on the reverse of this guide.
Lift window to replace SETUP printheads	The printer is prompting you to lift its window so that you can install 'normal' printheads. You must remove the setup printheads only after you have initialized the printer.	It is vital to the correct functioning of your printer that the setup procedure is performed correctly. Use the Setup Instructions that came with your printer to guide you through the steps.
Media loaded incorrectly. Remove media.	The printing material is mis-positioned or mis-aligned.	Before the printer can continue, you must remove the printing material and reload it correctly. See 34, in section <i>load and unload material</i> on the reverse of this guide.
Media misaligned. 1_ Lift lever 2_ Align Media with both edges of roll 3_ Lower lever	A roll has been loaded incorrectly.	See 34, in section <i>load and unload material</i> on the reverse of this guide. Remember to align the printing material coming out of the printer with the edge of the roll. Do not align it with the blue marks on the printer.
Media misaligned. 1_ Lift lever 2_ Align right edge with blue line 3_ Lower lever	A sheet has been loaded incorrectly.	See 54, in section <i>load and unload material</i> on the reverse of this guide.
Media mispositioned. 1_ Lift lever 2_ Correct position 3_ Lower lever	The roll is mis-positioned in the printer. This may mean it is too far to the left on the platen	For guidelines on loading rolls see 30, in section <i>load and unload material</i> on the reverse of this guide.
Media too small	The printing material you are attempting to load is too small for the printer to print the file.	In the case of an internal calibration, remember to use at least a D-sized printing material.

Status	Description	Procedure
Misalignment	This means that the printing material has not been fed into the printer straight.	Reload the printing material, making sure that the edges are parallel and that it is straight when you feed it in. Align the material coming out from the printer with the material going into the printer, see 34, in section <i>load and unload material</i> on the reverse of this guide.
Misposition	The printing material is not positioned correctly in the printer. It may be too far to the left or the right.	Check that you have loaded the printing material correctly as shown in the procedure 34, in section <i>load and unload material</i> on the reverse of this guide.
No media profile available.	The printer cannot find the internal media profile.	Unload any printing material in the printer and switch the printer off using the switch at the back. Switch on again. If the problem persists, call your support representative.
OK	The ink system is working correctly	
Preparing printheads	Your printer is servicing the printheads to maintain optimum print quality.	
Preventative maintenance advised	The printer has kept track of the number of cycles your printer has performed. This message means the printer needs maintenance to maintain its performance and to prevent printer down-time in the future.	Contact your support representative. Arrange a time that would be convenient for you and he will service the printer. See the "Using Your Printer" CD.
Printer temperature is out of the printer's operating range. Printer cannot function.	Under cold environmental conditions outside its operating range the printer will stop. It does this to protect the ink systems inside the printer.	Simply ensure the temperature is above 15 °C and turn the printer off and on again.
Printing Low memory	The printer previously compressed a print file while receiving it, and it is now expanding the file.	Printing will continue after expanding the data, but it will be slower than usual.
Processing	The printer has received a print file and is processing the information before starting to print.	

Status	Description	Procedure
Receiving	The printer is receiving a file.	If you have problems printing refer to the "Using Your Printer CD".
Receiving Low memory	While receiving a print file, the printer's memory has become low.	The printer will compress the file while it continues to receive the data.
XXXX Recover	There is a problem with one of the printheads you are using. To see which printhead has the problem, go to the printhead menu and press Enter .	See <i>printhead recovery procedure</i> , on page 38 for details.
Remove ink cartridge by pushing it in and up	This is an ink cartridge removal instruction.	See 67, in section <i>maintain the ink system</i> on the reverse of this guide.
Remove media weight Wind excess media using TUR button Press ENTER	When you are unloading a roll from the printer, you must remove the media weight from the take-up reel before you can complete the procedure.	If you do not want to use the take-up reel, you can turn off the setting by going to Utilities > TUR installed > No
XXXX Replace	A printhead needs to be replaced.	See <i>Printhead status messages</i> , on page 10.
Replace cleaner	The printer is designed so that when you replace a printhead you must also replace the printhead cleaner.	See 80, in section <i>maintain the ink system</i> on the reverse of this guide for details.
Replace ink cartridge	This is an ink cartridge removal instruction.	See 67, in section <i>maintain the ink system</i> on the reverse of this guide.
Reset Web Passwd	This is displayed when you are resetting your WebAccess password.	
Setup	The setup message is displayed when new tubes have been installed into the printer and you have installed the correct setup printheads	When the setting-up of the tube system is complete, the front panel will display a message asking you to remove the setup printheads and replace with 'normal' printheads.

Status	Description	Procedure
Sheet misaligned. Lift lever to align with blue line or to remove media.	This printing material has not been fed into the printer straight.	Reload the printing material making sure that the edges are parallel and that it is straight when you feed it in. Align the material coming out from the printer with the material going into the printer. See 34, in section <i>load and unload material</i> on the reverse of this guide.
Sheet required for calibration	The printer is prompting you to load printing material (at least D-sized) so that it can perform a calibration.	To see 54, in section <i>load and unload material</i> on the reverse of this guide.
Switch power off Check media path	There is a printing material jam in the printer.	Switch the printer off and clear the blockage. See 64, in section <i>printing material jam</i> on the reverse of this guide.
Switch power off Check printhead path	There is a printing material jam in the printer.	Switch the printer off and clear the blockage. See 64, in section <i>printing material jam</i> on the reverse of this guide.
Switch power off Restart printer startup with all ink cartridges	The ink system startup must have full cartridges installed to enable the initialization of the complete ink system.	Install the ink cartridges as shown in the Setup Instructions that came with your printer.
System error XXXXXX Switch off/on If problem persists contact HP support	The printer has experienced an unusual error; it may disappear if you switch off and then on again.	Switch off the printer using the power switch located at the rear. Then switch on again.
This media type supports Production PQ level. Press Enter to continue.	You may use the Production print mode with this printing material.	If you want to use the Production print mode, you can select it from your printer driver, from WebAccess, or from the front panel.
Waiting for nest	The printer is in the process of nesting.	See 136, in section <i>manage the prints</i> on the reverse of this guide for an explanation of nesting.
Warning! Ink cartridges are still functional. If you want to replace any, please select YES	The printer's ink cartridges are working correctly. You should remove them only if you are printing a large image unattended and there is insufficient ink remaining to finish the image.	For the cartridge removal procedure see 67, in section <i>maintain the ink system</i> on the reverse of this guide.

Status	Description	Procedure
<p>Warning ... supply ink level? (Error code 8x09) See user manual.</p>	<p>If you choose to continue printing with this ink supply you will not have an ink level indicator. You may not know when the ink supply is running low or empty. Printing with an empty ink supply may seriously damage your printhead, ink tubes, and printer. See below for a complete listing of features that will not be available with continued use of this ink supply. Any damage resulting from use of this supply or non-HP ink is not covered under your printer warranty.</p> <p>The following features will not be available as a result of using this supply.</p> <p>In the Ink Cartridge menu:</p> <ul style="list-style-type: none"> ■ Ink level indicator ■ Percentage of ink remaining <p>In WebAccess:</p> <ul style="list-style-type: none"> ■ Ink Cartridges status & Ink Level 	<p>Select Yes to replace it with a genuine HP 705 cartridge, No to continue.</p>
<p>Warning! Tubes System has reached its END OF LIFE. Contact HP Representative. Replace Tubes System.</p>	<p>The internal ink system inside your printer has reached the end of its life.</p>	<p>The ink system tubes have reached the end of their useful life. Please replace them before they break and damage the printer.</p>
<p>WARNING!!! You are going to reset the WebAccess Passwd.</p>	<p>You have a security setting for WebAccess. This is an optional setting. If you continue with the procedure, the password to gain access to WebAccess will be reset.</p>	<p>This setting is because you have forgotten, or do not know the password for entry into WebAccess. See the "Using Your Printer" CD for more details.</p>
<p>You need to cut this media manually</p>	<p>You have printing material loaded that is too thick or strong for the cutter to cut.</p>	<p>Use a knife or scissors to cut the printing material.</p>

Printhead status messages

See *Status code interpretation*, on page 2.

Status code XX ranges from 00 - 55	Printhead message description	Procedure
XX02 Reseat XX06 Reseat XX08 Reseat	The printhead may only be badly seated. This means there is a bad electrical connection between the printhead and the printer carriage.	Try these steps below. If the message returns to OK after performing the first step, do not continue. 1. Remove the printhead and insert the printhead again. 2. Remove the printhead and clean the interconnect, refer to <i>carriage interconnect wiper</i> , on page 56. 3. Replace the printhead.
XX10 Reseat	There is an electrical failure.	
XX03 Replace	Printhead smart chip failure.	Replace printhead.
XX04 Replace XX05 Replace	You have installed a new tubes system and the printer is priming them. The printer has detected that the setup printheads are still installed.	Remove the used setup printhead(s) and replace with normal ones.
XX09 Replace	There is an electrical failure.	Remove the printhead(s).
XX11 Replace	The printer has detected that you have installed an incorrect type of printhead.	Ensure that you have HP 705 printheads installed.
XX12 Replace	The printer detects that the printhead does not match the rest of the ink consumable items.	Ensure that all the ink consumable items are HP 705.

Status code XX ranges from 00 - 55	Printhead message description	Procedure
XX13 Replace	The smart chip inside the printhead contains incorrect information. The printer cannot print with this printhead.	Replace printhead(s).
XX14 Replace	The printhead has an internal electrical failure.	
XX15 Replace		
XX16 Replace	The printer was printing: Printhead temperature has reached an excessive level. It is possible to continue to print with this printhead, but it may void the printhead warranty if you continue for long periods.	
XX17 Replace		
XX18 Replace	The printhead smart chip detects an unsupported manufacturer.	
XX21 Replace	The printhead has reached a degradation level that prevents the printer producing acceptable image quality consistently.	<ol style="list-style-type: none"> 1. If the quality of your prints is fine, try a manual recovery and/or re-insertion. After this the printer may detect a recovery and will accept the printhead. 2. If after a recovery the message persists and the quality of your prints is unacceptable, replace the printhead(s) 3. To continue printing press Enter.
XX20 Recover	The printhead is losing its capability to produce the best image quality consistently. The printhead is still able to produce good image quality. However, this is the first symptom of an aging printhead.	If the image quality is acceptable, you will not need to take any action. Continue using the printhead until the "Replace" message is displayed. If the image quality is NOT acceptable, see <i>printhead recovery procedure</i> , on page 38.

Ink cartridge error messages

Status code XX ranges from 60 - 85	Ink cartridge message description	Procedure
XX02 Reseat	The ink cartridge may be badly seated. An electrical connection is faulty.	1. Remove the ink cartridge and re-insert. 2. Replace the ink cartridge.
XX03 Replace	The ink cartridge has an air leak that prevents the ink pumping to the printer.	1. Remove the ink cartridge and re-install. 2. Replace the ink cartridge
XX04 Replace	The smart chip inside the ink cartridge contains incorrect information. The error detected means that you cannot continue to use this ink cartridge.	
XX05 Replace	The printer has detected an incorrect ink cartridge	Ensure it is an HP 705 cartridge and that it is installed into the correct position.
XX06 Replace	The printer detects that the ink cartridge does not match the rest of the ink system already installed.	Ensure that the printheads and the ink cartridges are HP 705.
XX08 Unknown	Use genuine HP components for excellent image quality from your printer. If you choose to continue printing with this ink supply you may not have a properly functioning or reliable ink level indicator. The solid bar showing the ink level will be replaced by a patterned bar. You may not know when the ink supply is running low or empty. Printing with an empty ink supply may seriously damage your printhead, ink tubes, and printer. Any damage resulting from use of this supply or non-HP ink is not covered under your printer warranty.	Select Yes to replace your cartridge with a genuine HP 705 cartridge, No to continue.

Printhead cleaner error messages

Status code XX ranges from A0 - B5	Printhead cleaner message description	Procedure
XX03 Replace	The printhead cleaner installed is not recognized by the printer.	This may mean that the line sensor is dirty, so perform the lens replacement procedure. Ensure that you have replaced the printhead cleaner together with the printhead. Ensure that all the printhead cleaners installed are genuine HP 705.
XX05 Replace	The printhead detects that the printhead cleaner does not match the rest of the ink system already installed.	
XX06 Replace	The printer detects an incorrect printhead cleaner	

System error messages

What they mean

System errors are unusual printer malfunctions that may require an on-site visit from a support representative. There are two types of messages displayed.

Continuable

You can continue printing, but the printer is not functioning properly, and image quality may well be affected. It is strongly recommended that you contact your support representative and arrange an on-site visit; have the message and the system error code ready with you to quote.



Non-continuable

Turn the printer off and then on again, using the switch at the rear of the printer; the error may disappear. If the problem persists, contact your support representative and arrange an on-site visit; have the message and the system error code ready with you to quote.

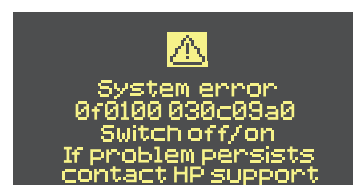



Troubleshooting image quality

6

- Correcting the configuration 6-2
- Using the image quality print 6-2
 - Printhead status check 6-2
 - Replacing 6-2
 - How to print the image quality print 6-3
 - How to use the image quality print 6-3
 - Analyzing the image quality print 6-3
 - No defects found in the image quality print 6-6
- Color accuracy 6-6
 - Configuration 6-6
 - Color consistency problems 6-7
 - Color accuracy configuration 6-7
- Printhead recovery procedure 6-8
- Accuracy calibration 6-8
 - To restore the factory's calibration 6-9
- Aligning the printheads 6-9
- Ink marks on the printing material 6-9
 - Warped lines 6-9
 - Blurred lines (ink bleeds from lines) 6-10
 - Marks and/or scratches on glossy paper 6-10
 - Smears or scratching on the image 6-10
 - Marks on the reverse of the printing material 6-10
- Automatic 6-11
- Manual 6-11
 - The printing material cannot be loaded successfully 6-12
- Other sources of information 6-13

Correcting the configuration

- 1 To achieve the best performance from your printer, only use **genuine** HP accessories and supplies, whose reliability and performance have been thoroughly tested to give trouble-free performance and best-quality prints. For details of HP printing materials, see the Using Your Printer CD. You can also look at the Web page <http://www.designjet.hp.com/> for the most up-to-date information.
- 2 Make sure that the **type of media** selected in the front panel is the same as the printing material loaded into the printer. To check this go to the Roll or Sheet menu in the front panel and press **Enter**.
- 3 Make sure that the **print mode** (Max Quality, Productivity, Production, Max Speed) is correct. Check that this is defined in the front panel and in the driver selection.
- 4 Select **Max Quality** print mode for maximum print quality.
- 5 For **Non-HP drivers**, set media settings to match the printing material loaded in the printer. See the documentation that came with your software for information.
- 6 If your image quality problem is related to **color accuracy**, go to *Color accuracy configuration, on page 7* for further configuration help.

Using the image quality print

The image quality print helps you determine whether you have an image quality problem, and if you do, what the cause of the problem is and how to resolve it. The print contains patterns designed to highlight any image quality problems.

Before printing and analyzing the Image Quality Print, it is recommended that you check the following:

Printhead status check

Check the printhead status in the front panel. Using the up and down keys, select the printhead icon; the front panel will then display the printhead status.

Replacing

If the printhead needs replacing, go to 73, in section *maintain the ink system* on the reverse of this guide and replace the printhead.

Recovering

If the printhead needs recovering, go to *Printhead recovery procedure, on*

page 8.

How to print the image quality print

Before you print the Image Quality Print you must ensure that you have A2- or C-size printing material (or larger) loaded into the printer.

To print the Image Quality Print use the front panel. Go to Utilities > Test Prints > Image Quality, select which of the four prints you want (see the following pages), and press the **Enter** key.

How to use the image quality print

- 1 Use the same printing material and image quality setting as you were using when you discovered the image quality problem.
- 2 Study each of the test patterns in the order that they are shown: 1 through 4.

Shown here is what the image quality print looks like:



Analyzing the image quality print

Plot 1: primary colors

The purpose of the particular part of the image Quality Print is to test the overall quality of the document with regard to dense colors.

The colored stripes are in the same order as they appear on the printer as if you are facing it: light cyan first and black last.

Each pair of colors is printed by only one printhead. So it's easy to find the root cause of the image quality problem.

This array of colored stripes is designed to check for certain defects in the

printer. It should not be used to check for color consistency or accuracy.

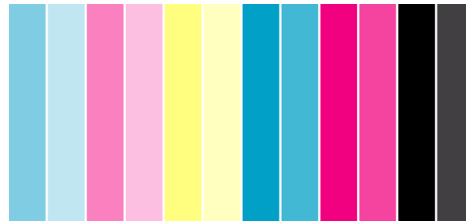

If your printer is functioning correctly this part of the print will have no problems. There is no banding in any of the colors.

However, if you do see problems with this print and the image quality is not acceptable, you will need to perform some corrective actions.

Banding

Banding has occurred when you see repetitive horizontal bands within the printed image. They can appear as light or dark bands.

Banding is caused by problems with:

- The printhead(s)
- Media advance

Problems with the printhead(s)

Banding caused by problems with the printhead(s) will be highlighted in the Image Quality Print because the banding is not in all of the colors: the colored strip that has banding was caused by the printhead of the same color. The colored stripes are in the same order as they appear on the printer as if you are facing it: light cyan first and black last.

For example, the image quality print shown below was printed with a printer that has a cyan printhead problem.

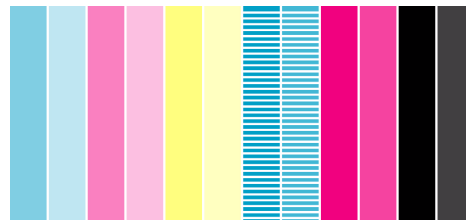

Corrective action

- 1** Perform the *Printhead recovery procedure*, on page 8 if you have not already done so
- 2** If there is no improvement in print quality, replace the problem printhead.

Problems with media advance

If the printer has media advance problems you will see banding in **all** the colors.

For example, the Image Quality Print shown below was printed with a

printer that has a media advance problem. **Note:** The bands appear light because the roller has advanced too much. The opposite could also be true, the bands could appear dark because the roller has not advanced sufficiently.



In high quality modes, due to the amount of ink used, media advance problems may not appear as lines of banding, they may appear grainy instead. The banding or graininess will appear in all the colors.

Corrective action

- 1 If the image is grainy, this could also be a symptom of problems with the bidirectional alignment. Refer to *Plot 3: bidirectional alignment, on page 5*. If this pattern is ok, go to step two.
- 2 Perform the *Accuracy calibration, on page 8* with the same printing material with which you were experiencing unacceptable image quality.
- 3 If there is no improvement in print quality, contact your support representative.

NOTE: It is also possible that this kind of banding was caused because you were using a printing material not supported by HP. Performance can be guaranteed only if you use supported HP materials.

Plot 2: color to color alignment

If the printer has color-to-color alignment problems then the Image Quality Print in plot 2 (shown below) has misaligned colors.



Corrective action

- 1 Perform the *Aligning the printheads, on page 9* with the same printing material with which you were experiencing unacceptable image quality.
- 2 If there is no improvement in print quality, contact your support representative.

Plot 3: bidirectional alignment

If a printer has bidirectional alignment problems, lines are fuzzy or not straight. The pattern seen below is designed to highlight this kind of problem. Check the lines on this test pattern; if they have any defects like the

ones described above, perform the corrective action.



Corrective action

- 1 Perform *Aligning the printheads*, on page 9 with the same printing material with which you were experiencing unacceptable image quality.
- 2 If there is no improvement in print quality, contact your support representative.

Plot 4: vertical line straightness

If a printer has vertical line straightness problems, lines are fuzzy or not straight. The pattern seen below is designed to highlight this kind of problem. Check the lines on this test pattern; if they have any defects like the ones described above, perform the corrective action.



Corrective action

- 1 Perform the *Aligning the printheads*, on page 9 with the same printing material with which you were experiencing unacceptable image quality.
- 2 If there is no improvement in print quality, contact your support representative.

No defects found in the image quality print

If the entire Image Quality Print contains no defects and you still experience image quality problems, listed below are some things to check:

- The print mode in the printer may be incorrect. See 8, in section *use the front panel* on the reverse of this guide.
- Check the driver you are using to print with, if it is a non-HP driver, go to <http://www.designjet.hp.com/> and download the correct HP driver.
- The settings in the non-HP RIP may be incorrect. Refer to the documentation that came with the RIP.
- The software applications you are using may have the wrong settings.

Color accuracy

These are two areas you should review when troubleshooting a color accuracy problem:

Configuration

Check the color emulation selected in the driver (or in the front panel if no driver is being used). Make sure the color information is adjusted for the

current color setup. See *Color accuracy configuration, on page 7*.

Color consistency problems

- Some printing materials may discolor or change with age. Check that your material is fresh and has been stored correctly.
- If the environmental conditions you are printing in change rapidly, you may see changes in the color consistency. By reducing the time the print stays in extreme environmental conditions after being printed (especially very high humidity) you can reduce the color consistency problems.

Long-term color bleeding (glossy papers)

If you see the colors are bleeding into the paper i.e. the color is soaking into the paper making the lines fuzzy and bleary. This is because of the humidity conditions that you are working under:

- Change the paper that you are printing with, or
- Remove the printer from the high humidity conditions.
- Do not cover or stack the printed images after printing.

Color accuracy configuration

The configurations of the printer, the driver, and the RIPs define how ink is applied to each type of printing material. Use the information in the following table to configure your printer and software for best color accuracy.

Location of Setting	Setting Description	Selection
Printer front-panel menu	Select media type	Set to match the printing material loaded in the printer.
	Ink emulation mode: RGB	Set the type of colors that your software generates.
Non-HP drivers (external software or hardware RIPs)	Paper type or equivalent	Set to match the printing material loaded in the printer. See the documentation that came with your software for information.
	Color correction or equivalent	Perform the color correction calibration if one is available.

Where to find additional information

The means of accurately managing the colors printed by your printer vary with the software application and driver being used. Refer to the following documentation:

- The *Software Application Notes* for your application, in the package shipped with your printer.
- The online documentation for the drivers shipped with your printer.

- Remember that your printer may be configured to use one of its internal pen palettes instead of your software's palette (which is the default). See the Using Your Printer CD.

Printhead recovery procedure

Recovering the printhead(s) means that the printer automatically cleans and tests the printhead(s).

To recover the printhead perform the following procedure:

- 1 Using the ↑ or ↓ keys select the printhead icon in the front panel.
- 2 Press **Enter**. The front panel displays:
- 3 Using the ↑ or ↓ keys select "Recover printheads".
- 4 Press **Enter**. The front panel displays:
- 5 Using the ↑ or ↓ keys select the printhead(s) that you need to recover or if you are not sure select "**All Printheads**"



Accuracy calibration

Your printer was calibrated at the factory to ensure that it operates with the greatest accuracy in normal environmental conditions. If you are operating under significantly different conditions, you should recalibrate the printer as explained here. The printer's environmental specifications are given in the Using Your Printer CD. You may also need to recalibrate the printer if you have image quality problems.

To recalibrate the printer:

- 1 Go to Utilities > Calibrations > Accuracy > Recalibrate.

- 2 Choose Create pattern. The front panel displays:
- 3 When the calibration print has finished printing the printer will cut the material.
- 4 Reload the image just printed into the printer with the arrows facing downwards, so that the black arrows emerge from the printer facing upwards.
- 5 Go to recalibrate again, and choose Measure pattern.

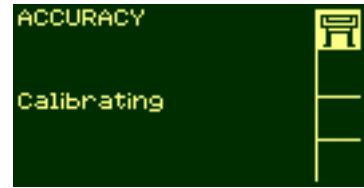

When the printer has finished measuring and has ejected the sheet, the recalibration procedure is finished. The front panel will confirm that the printer recalibrated successfully.

If there is an error with the calibration, the front panel will display an error message and an error code. Make a note of the error code and contact your support representative.

To restore the factory's calibration

If you notice after calibration that your image quality is worse than before, you can return to the original settings: choose Utilities > Calibrations > Accuracy > Restore Factory.

Aligning the printheads

The printhead alignment selection causes the printer to align the printheads immediately; or, if an image is being printed, as soon as the current print job is finished. The alignment procedure requires a minimum paper size of A1/D-size (24 inches).

To perform the printhead alignment procedure go to Utilities/ Calibrations/ Printhead Alignment. You can use this feature if the print quality print indicates an alignment error. Refer to *Using the image quality print, on page 2*.

The printer will automatically perform an alignment when printheads are replaced, unless you have turned off this behavior from the front panel: Internal RIP Setting > Align Calibration > Off.

Ink marks on the printing material

For detailed printing tips, troubleshooting, printing compatibility and new product information, visit our Web site at:

<http://www.designjet.hp.com/>

Warped lines

The printing material itself may be warped. This can happen if it has been

used or stored in an extreme environment. For all environmental specifications, see Environmental Specifications in the Using Your Printer CD.

Blurred lines (ink bleeds from lines)

Perhaps you have adjusted the drying time in the front-panel menu to speed up the printer output. Set "Drying time" to "Automatic".

For details of drying time adjustments, see the Using Your Printer CD.

Marks and/or scratches on glossy paper

Glossy paper may be extremely sensitive to the bin or anything with which it comes into contact directly after printing. This will depend on the amount of ink printed and the environmental conditions that are present at the time of printing. Avoid any contact with the paper and handle the print with care until some time has elapsed.

Smears or scratching on the image

This problem can appear on coated paper if a lot of ink was printed. The paper absorbs the ink quickly and expands. As the printheads move over the paper, the printheads and the paper come into contact with each other and the printed image is smeared.

- 1** Press the **Cancel** key on the front panel; if you continue to print, the paper may damage the printheads.
- 2** Cancel the print job from your computer application.

In order to obtain better results, try the following suggestions:

- Use HP-recommended paper. If the image you are printing has intense color, try using HP Heavyweight Coated Paper through the front panel.
- Use extended margins (see the Using Your Printer CD), or try to increase the print margins by relocating the image in the page from your software application.
- If you are using 'Media Saving Options' from the advanced section of the HP-GL/2 driver, try disabling one or both of the options 'auto rotate' and 'inked area'.
- Use the take-up reel if you have one installed.

If these suggestions fail to solve the problem of smears and scratching, consider changing to a non-paper-based material such as glossy film.

Marks on the reverse of the printing material

Marks underneath or at the edges of the printing material can be caused by accumulated ink deposits on the platen transferring to the printing material. The ink deposits can be seen mostly in the areas where the edge of your material rests on the platen. The printer routinely removes these ink deposits

every time you load a roll. However, depending on your printer usage, this is sometimes not sufficient. There are two procedures for cleaning the platen, Automatic and Manual.

Automatic

This setting enables you to remove the ink deposits from the platen using the printing material you have loaded. The printer moves a portion of the material backwards and forwards over the platen. To manually trigger the automatic cleaning process go to Utilities > Clean Platen > Automatic.

Manual

This section explains the manual platen cleaning process.

NOTE: Ensure that you have unloaded all printing material before performing these procedures.

- 1 Open the window.

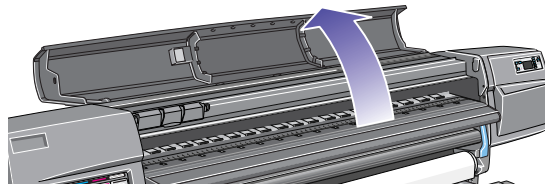

- 2 With a dry brush, remove the ink deposits from the cutter groove.

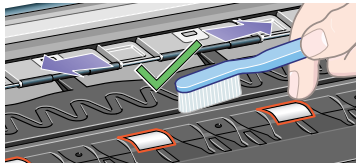

- 3 With the same dry brush, remove the ink deposits from the platen surface.

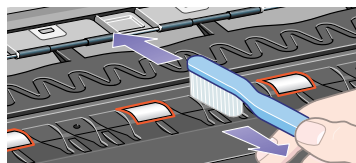

- 4 Use a clean, slightly damp, absorbent lint-free cloth to wipe off the loosened ink deposits from the platen. However, do not wipe the platen wheels with this cloth.

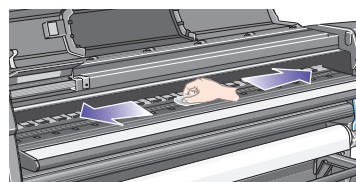

CAUTION Do not use commercial cleaners or abrasive cleaners. Do not wet the platen directly because you will leave too much moisture behind.

NOTE: Use isopropyl alcohol to dampen the cloth.

- 5 Clean the cutter ramp as shown below with the damp cloth.

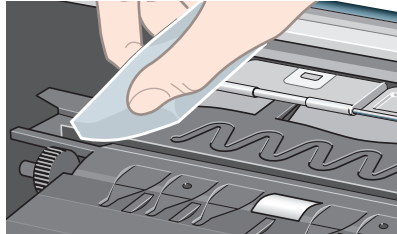

- 6 Clean the exposed part of the wheels as shown below with a slightly-damp absorbent lint-free cloth. It is important that the cloth is not too damp, otherwise you will leave too much moisture behind and the wheels will not work well.

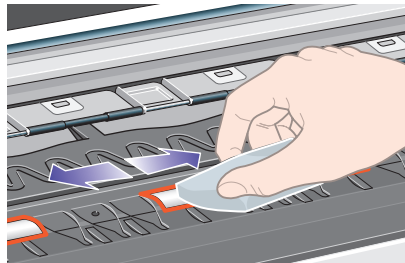

To turn the platen wheels and clean the whole circumference:

- 7 Close the printer's window.
- 8 Select the Printer Setup menu in the front panel.
- 9 Select Utilities > Clean Platen > Clean Now > Manual.
- 10 Open the printer window.
- 11 Use the ↓ & ↑ keys to move the wheels through a fifth of a turn.

WARNING Do not touch the rotating wheels directly with your hands.



- 12 Clean the exposed part of the wheels.
- 13 Repeat steps 11 and 12 three more times to clean the whole circumference of the wheels.
- 14 Close window to exit.

The printing material cannot be loaded successfully

Rolls

- The roll may be loaded the wrong way. The paper should load over the roll toward you.

- The roll may be crumpled or warped or may have irregular edges.
- The paper may be loaded at an angle. The right-hand edge must be aligned with the edges of the roll.
- Ensure that the paper is wound tightly on the roll.
- Check that the paper is correctly loaded onto the spindle.

Sheets

- It must be loaded with the right-hand edge against the blue perforated line on the printer.
- Align the sheet against the trailing edge coming out of the printer.
- The sheet may be crumpled or warped or may have irregular edges.
- If you are using a hand-cut sheet, the edges may not form a right angle or they may be rough. Do not use hand-cut sheets; use only purchased sheets.
- Refer to 30, in section *load and unload material* on the reverse of this guide.

Prints do not stack properly in the bin

- The printer may be too close to the end of the roll. The natural curl near the end of the roll can cause stacking problems. Load a new roll or remove prints manually as they are completed.
- If you are mixing prints or nesting sets of several different sizes, you may have stacking problems because of the different sizes of printing material in the bin.

Other sources of information

If you don't find the solution to the problem here, other sources of help are:

- The documentation supplied with the driver that you are using to manage the output from your software application to the printer.
For example, the online and printed documentation included in the HP-GL/2 drivers (for Windows NT 4.0/2000/XP) supplied with your printer.
- The HP-GL/2 driver documentation supplied with your application software.
- There is also documentation on the WebAccess tool. Refer to 128, in section *manage the prints* on the reverse of this guide.



Troubleshooting the ink supply

7

- Ink system error/status messages 7-2
 - (error code) Replace 7-2
 - (error code) Reseat 7-2
 - (error code) Recover 7-3
- Recovery procedure 7-3
- Solving ink supply problems 7-4
 - Problems re-seating the printhead 7-4
 - You cannot insert the ink cartridge into the printer 7-4
 - You cannot insert the printhead into the printer 7-4
 - Problems inserting the printhead cleaner 7-4
 - Carriage interconnect wiper 7-5

Ink system error/status messages

Your printheads are manufactured to last a long time. However, over time they will degrade and after a while they will need to be replaced. The error/status messages are designed to keep you informed of the status of your ink supplies.

The example below shows a printhead with an error.

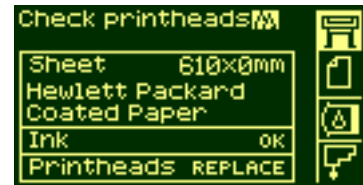

To find out exactly which printhead has the error, select the printhead icon as shown below.

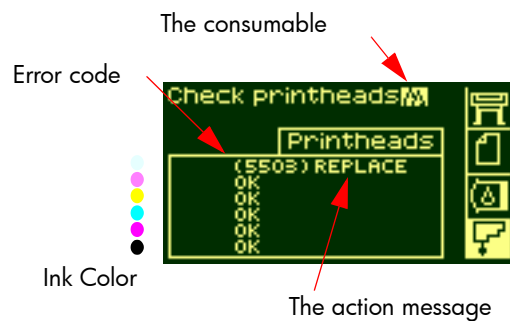

The front-panel display will change to show the current status of all the printheads.

The error/status message has two parts:

- The action message
- The error code

The action indicated by the message must be performed first to correct the error. If this is unsuccessful, use the error code to try to correct the problem. To interpret the error codes, refer to *status code interpretation, on page 2*.

There are three action messages:

(error code) Replace

The Replace message means that you must remove the consumable and replace it with a new one. Since the only action that you can do is to remove and replace with a new part or the correct part, the error code is given mainly for use by a support technician. For the removal procedure, see 73, in section *maintain the ink system* on the reverse of this guide.

(error code) Reset

The Reset message means that the electrical connection between the

printhead and the carriage assembly is not good.

- 1 The printhead needs to be removed and inserted again.
- 2 If this is unsuccessful, the printhead and/or carriage may need to be cleaned. See *Carriage interconnect wiper, on page 5*.
- 3 If this is also unsuccessful, replace the part.

(error code) Recover

The Recover message is shown on the printhead information screen. Recovery is an optional procedure that you can use if the image quality is unacceptable. If after this the image quality has not improved sufficiently, try another recovery. If this still doesn't work, replace the part. For details of how to perform this procedure, see *Recovery procedure, on page 3*.

Recovery procedure

Recovering the printhead(s) means that the printer automatically cleans and tests the printhead(s).

To recover the printhead perform the following procedure:

- 1 Using the ↑ or ↓ keys select the printhead icon in the front panel.
- 2 The front panel displays:
- 3 Press **Enter**. The front panel displays:
- 4 Using the ↑ or ↓ keys select "Recover printheads".

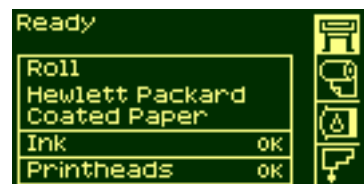

- 5 Press **Enter**. The front panel displays:
- 6 Using the \uparrow or \downarrow keys select the printhead(s) that you want to recover.



Solving ink supply problems

Most of the problems that you could encounter when working with the HP 705 supplies are solved with guidance from the front panel. A full list of front panel messages is supplied, see *status code interpretation*, on page 2.

Problems re-seating the printhead

If you have inserted the printhead into the printhead carriage assembly, and the printer does not “beep”, perform the following steps.

- Check that you have removed the protective tape from the printhead.
- Insert the printhead into the carriage assembly but this time close the cover using the latch.
- Clean the electrical contacts on both the printheads and the printhead carriage assembly using the carriage interconnect wiper procedure. See *Carriage interconnect wiper*, on page 5.
- Replace the printhead with a new one.

You cannot insert the ink cartridge into the printer

- 1 Ensure that you have the correct HP 705 ink cartridge.
- 2 Ensure that the cartridge is the correct color for that slot.
- 3 Ensure that the cartridge is correctly oriented, with the color-coded label at the top.

CAUTION Never clean inside the ink cartridge slots.

You cannot insert the printhead into the printer

- 1 Ensure that you have the correct HP 705 printhead.
- 2 Ensure that the printhead is the correct color for that slot.
- 3 Ensure that the printhead is correctly oriented.

See 77, in section *maintain the ink system* on the reverse of this guide for details.

Problems inserting the printhead cleaner

- 1 Ensure that you have the correct HP 705 printhead cleaner.
- 2 Ensure that the printhead cleaner is the correct color for that slot.
- 3 Ensure that the printhead cleaner is correctly oriented.

See 83, in section *maintain the ink system* on the reverse of this guide for details.

Carriage interconnect wiper

When you replace the printhead, check the empty slots to see whether they need cleaning. In some extreme cases it is possible that the printer will not recognize a printhead when it has been installed. This is due to the build-up of ink deposits on the electrical connections between the printhead and the printhead carriage.

Included with your printer is a carriage interconnect wiper. This should be used for cleaning the electrical interconnects of both the printhead carriage and the printhead.

This procedure should be performed every time you replace a printhead.

If the front panel persistently displays the message **“Reset”** next to the printhead, try performing the procedure shown here.

NOTE: After waiting a few moments to allow both connectors to dry, replace the printhead into the carriage assembly. Use the procedures in 73, in section *maintain the ink system* on the reverse of this guide.

NOTE: Do not touch, wipe, or attempt to clean the printhead nozzles. This can damage the printhead and reduce print quality.

- 1 To clean the carriage electrical interconnect, remove a new pre-moistened replacement sponge from its pouch. A supply of sponges is included in the box with the tool. If all sponges have been used, more can be obtained by contacting your customer service representative.

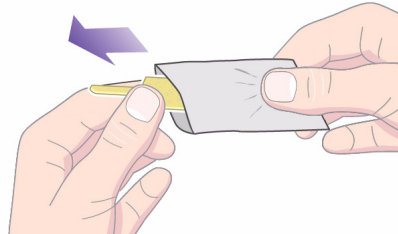

- 2 Open the carriage interconnect wiper.

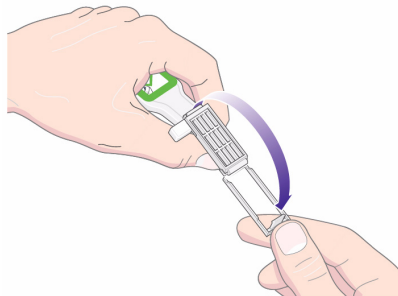

- 3** Load the sponge into the carriage interconnect wiper by positioning the sponge on the face of the carriage interconnect wiper with the shorter tab in the locating slot.

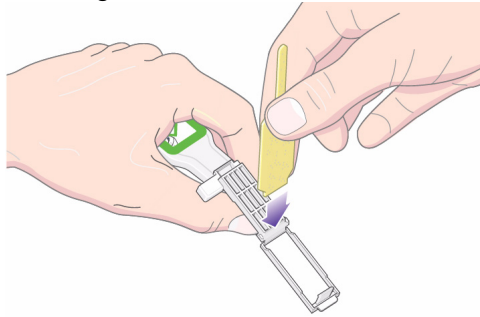

- 4** Close the carriage interconnect wiper trapping the sponge in place.

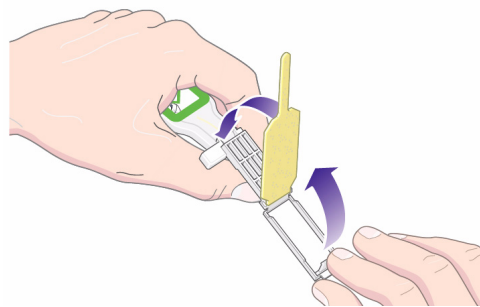

- 5** Open the printhead carriage latch and extract the printhead that has the problem, as indicated on the front panel. Use the procedures in 73, in section *maintain the ink system* on the reverse of this guide.
- 6** Insert the carriage interconnect wiper into the printhead slot at the back. Wipe the electrical contacts by inserting the tool between the electrical connections at the back of the slot and the steel spring with the sponge facing away from you, towards the electrical contacts.

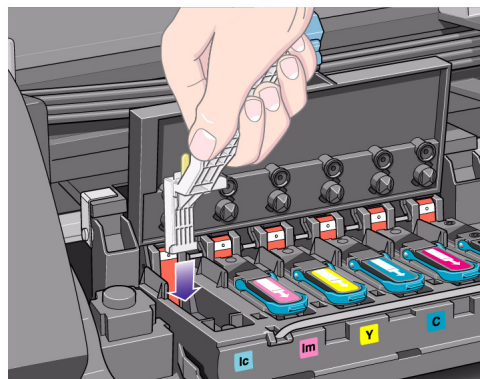

- 7** Rub the sponge against the contacts with a **light** force along the entire depth of the flex connector as allowed by the mechanical stop on the tool.

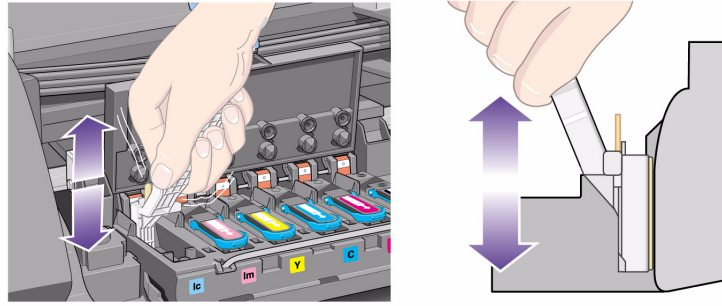

- 8** Take special care to clean all contacts thoroughly, including the ones at the lowest point of the connector.

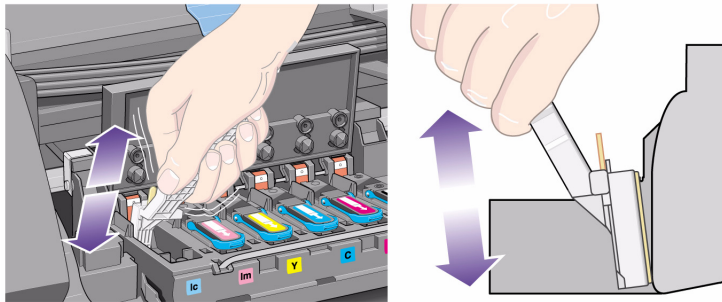

- 9** Using the same sponge, clean the electrical contacts on the printhead.

Do not clean here

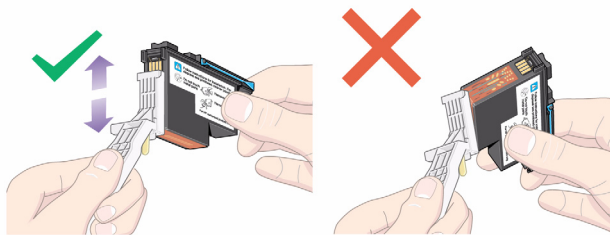

CAUTION

Do not touch the surface of the printhead containing the nozzles as it may damage them.

- 10** After waiting a few moments to allow both connectors to dry, replace the printhead into the printhead carriage as instructed by the *Printhead Installation* procedure.

NOTE: If the problem still persists, replace the printhead or call your support

representative.

- 11** On completion of the cleaning process, open the carriage interconnect wiper by pulling on the sponge tab.

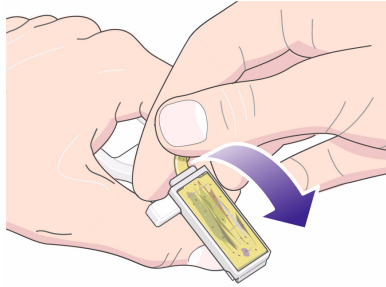

- 12** Remove the soiled sponge from the carriage interconnect wiper.

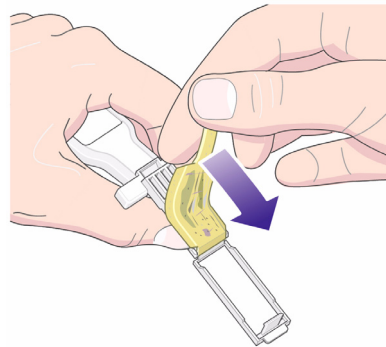

- 13** Dispose of the soiled sponge in a safe place to prevent the transfer of ink onto hands and clothing.

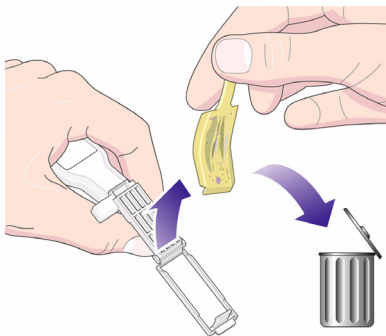



Troubleshooting print material jams



Clearing a printing material jam 8-2

Check printhead path 8-2

Check media path 8-3

Clearing a printing material jam

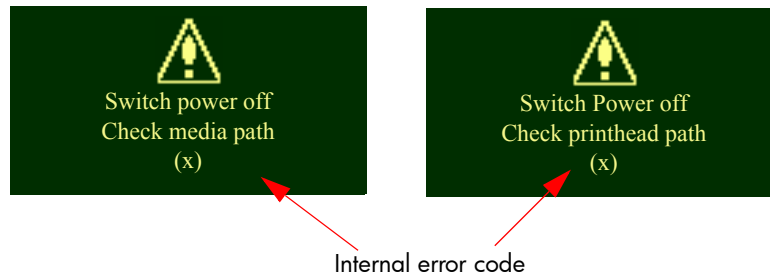

The “Switch Power Off” message is usually shown when there is a printing material jam.

The printer must be cleared before the printer can operate again. There are two types of printing material jams:

- A jam that prevents the carriage from moving from one side of the printer to the other. This is called Printhead Path jam. See *Check printhead path, on page 2*.
- A jam that prevents the material advancing into the printer correctly. This is called a Media Path jam. See *Check media path, on page 3*.

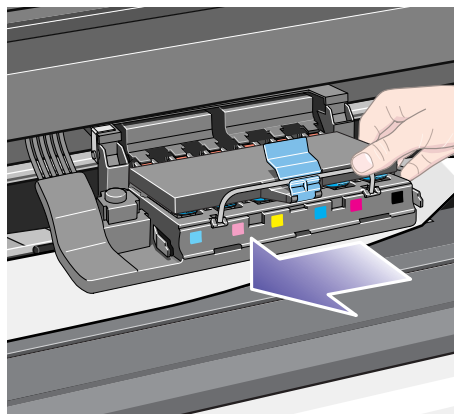

Check printhead path

- 1** Switch the printer off at the rear of the printer and open the window.
- 2** Look in the area where the printer was printing at the time of the jam, this is where the printing material is most likely to be jammed.
- 3** Lift the media load lever.
- 4** Carefully remove any of the jammed printing material that you can lift up and out from the top of the printer.
- 5** Carefully pull the rest of the roll or sheet down and out of the printer.
- 6** If you are using a roll, trim the printing material with a knife as shown in 34, in section *load and unload material* on the reverse of this guide.
- 7** Reload the roll; see 34, in section *load and unload material* on the reverse of this guide.

- 8 Switch the printer on.
- 9 If there is some printing material left behind in the media path, loading paper can become difficult. This can be cleared by loading a rigid paper type through the printer media path.
- 10 If you have image quality problems after a paper jam, this could indicate that the printheads have been moved from their correct position in the carriage. To correct this, perform *aligning the printheads*, on page 41.

Check media path

- 1 Switch the printer off at the rear of the printer.
- 2 Check that the roll has not almost finished and is stuck to the empty cardboard core.
- 3 Load a new roll

Contact your support representative

If after performing all of these procedures the front panel displays the "Switch Power Off" message again, make a note of the message with the error code and contact your support representative.



Legal and service information

9

- Customer Service Guide 9-2
- Hewlett-Packard limited warranty statement 9-5
- Regulatory Notices 9-7
- Sound 9-10
- Address 9-10
- Declaration of conformity 9-11
- Energy Star information 9-13

Customer Service Guide

Enjoy a world of dedicated services and resources to ensure you always get the best performance from your HP Designjet products and solutions.

Serving your business round the clock

HP Designjet Online, your large format printing community at www.hp.com/go/designjet, gives:

- downloads
- technical support
- forums
- warranty tracking
- news services
- technical documentation
- product information
- ink and media information

... and all customizable for the product you have purchased and your business.

HP Designjet Online is available in English, German, French, Italian, Spanish, Portuguese, Japanese, Traditional Chinese, Simplified Chinese and Korean.

HP Warranty Services - peace of mind

Your HP Designjet 12-month warranty gives you:

- 24-hour online Web support at HP Designjet Online
- professional telephone support (see back cover for your country phone number)
- repair services: next business day, at the customer site, or exchange, depending on the product and the country.

NOTE: The level of warranty service may vary according to local standards. Refer to your warranty statement document for the terms and conditions applicable. Please check the availability of these HP Designjet services in your country through the Support Options of HP Designjet Online, or contact your HP reseller or call HP directly.

The best option for printing support - HP Care Pack Services

HP Care Pack Services offer upgraded service levels to extend and expand your standard product warranty with easy-to-buy, easy-to-use support packages that help you make the most of your investments. You can choose the support levels that meet your business requirements, from installation to warranty coverage extension or 4-hour response. These services are

available by contacting your HP sales representative or HP reseller.

Register and win!

Register your product, and by giving HP some extra information, you will be able to participate in HP programs and receive great gifts. Register your product at:

www.register.designjet.hp.com

Customer care centers

You can contact HP directly by calling the HP Customer Care Center in your country. For the most current phone numbers, please go to <http://welcome.hp.com/country/us/eng/wwwcontact.html>.

Response time for our services may vary depending on local distance of your site from the nearest HP support office. Business day = Monday - Friday, excluding HP holidays.

The only warranties for HP products and services are set forth in the express warranty statements accompanying such products and services. Nothing herein should be construed as constituting an additional warranty. To the extent allowed by local law, HP shall not be liable for technical or editorial errors or omissions contained herein.

Algeria: 213 17 63 80
Argentina: 0 800 777 HP INVENT, local 5411 4778 8380
Australia: 13 10 47
Austria: 0810 00 10 00
Bahrain: 800 171
Belgium: (0) 78 600 600
Bolivia: 0 800 1110, local 54 11 4708 1600
Brazil: 0800 157 751, local 55 11 3747 7799
Canada: 1 800 HP INVENT
Caribbean: 1 800 711 2884
Central America: 1 800 711 2884
Chile: 800 HP INVENT, 123 800 360 999
China: 800 810 59 59, 10 6564 59 59
Colombia: 01 8000 51 HP INVENT, local 571 606 9191
Czech Rep: 420 261 307 310
Denmark: 70 11 77 00
Ecuador: 999 119, 1 800 225 528
Egypt: 202 532 5222
Finland: 0203 53232
France: 08 26 10 49 49
Germany: 0180 52 58 143
Greece: 210 6073603, 801 11 22 55 47
Guadalupe: 0800 99 00 11, 877 219 8791
Guatemala: 1 800 999 5105, 1 800 711 2884
Hong Kong: 852 3002 8555
Hungary: 06 1 382 1111
India: 1 600 112 267
Indonesia: 350 3408

Ireland: 1 890 946500
Israel: 09 830 4848
Italy: 02 3859 1212
Jamaica: 0 800 711 2884
Japan: Software 0120 014121, Hardware 0120 742594
Korea: 82 1588 3003
Luxemburg: 27 303 303
Malaysia: 1 800 80 5405
Martinica: 0 800 99 00, 877 219 8671
Mexico: 01 800 472 6684, local 5258 9922
Middel East: 4 366 2020
Morocco: 2240 4747
Netherlands: 0900 1170 000
New Zealand: 09 365 9805
Norway: 800 62 800
Paraguay: 00 811 800, 800 711 2884
Panama: 001 800 711 2884
Peru: 0 800 10111
Philippines: 632 888 6100
Poland: 22 566 6000
Portugal: 213 164 164
Puerto Rico: 1 800 652 6672
RSA: 27 11 258 9301, local 086 000 1030
Romania: 40 21 315 4442
Russia: 095 797 3520, 812 3467 997
Saudi Arabia: 6272 5300
Slovakia: 2 50222444
South Africa: 0800 001 030
Spain: 902 010 333
Sweden: 077 130 30 00
Switzerland: 0848 80 20 20
Taiwan: 886 2 872 28000
Thailand: 0 2353 9000
Tunisia: 71 89 12 22
Turkey: 216 444 71 71
UAE: 800 4520, 04 366 2020
Ukraine: 44 4903520
United Kingdom: 0870 842 2339
United States: 1 800 HP INVENT
Uruguay: 54 11 4708 1600
Venezuela: 0 800 HP INVENT, local 58 212 278 8000
Vietnam: 84 8 823 45 30
West Africa (French): 351 213 17 63 80

Hewlett-Packard limited warranty statement

HP Designjet 5100 Series

HP product	Duration of limited warranty
Printer and related HP hardware	1 year (from the date of purchase by the customer)
Software	90 days (from the date of purchase by the customer)
Printhead	Until the "end of warranty" date printed on the product is reached, or 700 cc of HP ink have been cycled through the printhead, whichever occurs first
Ink cartridge	Until the genuine HP ink is depleted as indicated by the printer, or the "end of warranty" date printed on the product is reached, whichever occurs first

A. Extent of limited warranty

- 1** Hewlett-Packard (HP) warrants to the end-user customer that the HP products specified above will be free from defects in materials and workmanship for the duration specified above. Customer is responsible for maintaining proof of date of purchase.
- 2** For software products, HP's limited warranty applies only to a failure to execute programming instructions. HP does not warrant that the operation of any product will be uninterrupted or error free.
- 3** HP's limited warranty covers only those defects which arise as a result of appropriate use of the product, and does not apply to any:
 - a** Improper or inadequate maintenance or modification;
 - b** Software, interfacing, media, parts, or supplies not provided or supported by HP; or
 - c** Operation outside the product's specifications.

Routine printer maintenance operations in the HP Designjet 5100, such as cleaning and preventive maintenance services (including parts contained in any preventive maintenance kit and HP service engineer visits), are not covered by HP's limited warranty, but in some countries may be covered under a separate support contract.

- 4** For HP printer products, the use of a refilled or non-original HP consumable product (ink, printhead or ink cartridge) does not affect either the warranty to the customer or any HP support contract with the customer. However, if printer failure or damage is attributable to the use of a non-HP or refilled ink cartridge, HP will charge its standard time and materials charges to service the printer for the particular failure or damage.

- 5 If HP receives, during the applicable warranty period, notice of a defect in any software, media, or consumable product which is covered by HP's warranty, HP shall deliver another product to customer to replace the defective one. If HP receives, during the applicable warranty period, notice of a defect in any hardware product which is covered by HP's warranty, HP shall either repair or replace the defective product, at HP's option. A replacement part, in return for a defective one and remote part installation assistance, if needed, may be provided to the customer, at HP's option. HP may, at its option, waive the requirement for the customer to return the defective part.
- 6 If HP is unable to repair or replace, as applicable, a defective product which is covered by HP's warranty, HP shall, within a reasonable time after being notified of the defect, refund the purchase price for the product.
- 7 HP shall have no obligation to repair, replace, or refund until the customer returns the defective product to HP.
- 8 Any replacement product may be either new or like-new, provided that it has functionality at least equal to that of the product being replaced.
- 9 HP products may contain remanufactured parts or components equivalent to new in performance or may have been subject to incidental use.
- 10 HP's limited warranty is valid in any country or locality where HP has a support presence for this product and where HP has marketed this product. The level of warranty service you receive may vary according to local standards. HP will not alter form, fit or function of the product to make it operate in a country for which it was never intended to function for legal or regulatory reasons.

Contracts for additional services may be available for any authorized HP service facility where the listed HP product is distributed by HP or an authorized importer.

B. Limitations of warranty

- 1 TO THE EXTENT ALLOWED BY LOCAL LAW, NEITHER HP NOR ITS THIRD PARTY SUPPLIERS MAKE ANY OTHER WARRANTY OR CONDITION OF ANY KIND, WHETHER EXPRESS OR IMPLIED, WITH RESPECT TO THE HP PRODUCTS, AND SPECIFICALLY DISCLAIM THE IMPLIED WARRANTIES OR CONDITIONS OF MERCHANTABILITY, SATISFACTORY QUALITY, AND FITNESS FOR A PARTICULAR PURPOSE.

C. Limitations of liability

- 1 To the extent allowed by local law, the remedies provided in this Warranty Statement are the customer's sole and exclusive remedies.
- 2 TO THE EXTENT ALLOWED BY LOCAL LAW, EXCEPT FOR THE OBLIGATIONS SPECIFICALLY SET FORTH IN THIS WARRANTY STATEMENT, IN NO EVENT SHALL HP OR ITS THIRD PARTY SUPPLIERS BE LIABLE FOR DIRECT, INDIRECT, SPECIAL, INCIDENTAL, OR CONSEQUENTIAL DAMAGES, WHETHER BASED ON CONTRACT, TORT, OR ANY OTHER LEGAL THEORY AND WHETHER ADVISED OF THE POSSIBILITY OF SUCH DAMAGES.

D. Local law

- 1** This Warranty Statement gives the customer specific legal rights. The customer may also have other rights which vary from state to state in the United States, from province to province in Canada, and from country to country elsewhere in the world.
- 2** To the extent that this Warranty Statement is inconsistent with local law, this Warranty Statement shall be deemed modified to be consistent with such local law. Under such local law, certain disclaimers and limitations of this Warranty Statement may not apply to the customer. For example, some states in the United States, as well as some governments outside the United States (including provinces in Canada), may:
 - a** Preclude the disclaimers and limitations in this Warranty Statement from limiting the statutory rights of a consumer (e.g. the United Kingdom);
 - b** Otherwise restrict the ability of a manufacturer to enforce such disclaimers or limitations; or
 - c** Grant the customer additional warranty rights, specify the duration of implied warranties which the manufacturer cannot disclaim, or not allow limitations on the duration of implied warranties.
- 3** FOR CONSUMER TRANSACTIONS IN AUSTRALIA AND NEW ZEALAND, THE TERMS IN THIS WARRANTY STATEMENT, EXCEPT TO THE EXTENT LAWFULLY PERMITTED, DO NOT EXCLUDE, RESTRICT, OR MODIFY, AND ARE IN ADDITION TO, THE MANDATORY STATUTORY RIGHTS APPLICABLE TO THE SALE OF HP PRODUCTS TO SUCH CUSTOMERS.

Revision: September 1st, 2002

Regulatory Notices

You can obtain current Material Safety Data Sheets for the ink systems used in the printer by mailing a request to this address: Hewlett-Packard Customer Information Center, 19310 Pruneridge Avenue, Dept. MSDS, Cupertino, CA 95014, U.S.A. There is also a Web page:

http://www.hp.com/hpinfo/community/environment/productinfo/psis_inkjet.htm

Regulatory Model Number

For regulatory identification purposes, your product is assigned a Regulatory Model Number. The Regulatory Model Number for your product is BCLAA-0604. This regulatory number should not be confused with the marketing name (such as HP Designjet printer) or product numbers (such as Z####X

where Z and X are any single letter and # is any number).

Regulatory statements

Electro-Magnetic Compatibility (EMC)

FCC statements (U.S.A.)

The U.S. Federal Communications Commission (in 47 cfr15.105) has specified that the following notices be brought to the attention of users of this product.

This device complies with part 15 of the FCC rules. Operation is subject to the following two conditions: (1) this device may not cause harmful interference, and (2) this device must accept any interference received, including interference that may cause undesired operation.

Shielded cables

Use of shielded data cables is required to comply with the Class B limits of Part 15 of the FCC Rules.

Caution: Pursuant to Part 15.21 of the FCC Rules, any changes or modifications to this equipment not expressly approved by the Hewlett-Packard Company may cause harmful interference and void the FCC authorization to operate this equipment.

Note: This equipment has been tested and found to comply with the limits for a Class B digital device, pursuant to part 15 of the FCC Rules. These limits are designed to provide reasonable protection against harmful interference in a residential installation. This equipment generates, uses and can radiate radio frequency energy and, if not installed and used in accordance with the instructions, may cause harmful interference to radio communications. However, there is no guarantee that interference will not occur in a particular installation. If this equipment does cause harmful interference to radio or television reception, which can be determined by turning the equipment off and on, the user is encouraged to try to correct the interference by one or more of the following measures:

- Reorient the receiving antenna.
- Increase the separation between the equipment and the receiver.
- Connect the equipment into an outlet on a circuit different from that to which the receiver is connected.
- Consult your dealer or an experienced radio/TV technician.

You may find useful the following booklet prepared by the FCC: "How to Identify and Resolve Radio-TV Interference Problems". This booklet is available from the US Government Printing Office, Washington, DC 20402, Stock No. 004-000-00345-4.

When connected to LAN cables using print server accessories:

This equipment has been tested and found to comply with the limits for a Class A digital device, pursuant to part 15 of the FCC Rules. These limits are designed to provide reasonable protection against harmful interference in a commercial environment. This equipment generates, uses, and can radiate radio frequency energy and, if not installed and used in accordance with the instructions, may cause harmful interference to radio communications. Operation of this equipment in a residential area is likely to cause harmful interference, in which case the user will be required to correct the interference at their own expense.

Normes de sécurité (Canada)

Le présent appareil numérique n'émet pas de bruits radioélectriques dépassant les limites applicables aux appareils numériques de Classe B prescrites dans le règlement sur le brouillage radioélectrique édicté par le Ministère des Communications du Canada.

Connecté à un réseau par des accessoires de serveur, l'appareil n'émet pas de bruits radioélectriques dépassant les limites applicables aux appareils numériques de Classe A prescrites dans le règlement sur le brouillage radioélectrique édicté par le Ministère des Communications du Canada.

DOC statement (Canada)

This digital apparatus does not exceed the Class B limits for radio noise emissions from digital apparatus set out in the Radio Interference Regulations of the Canadian Department of Communications.

When connected to LAN cables using print server accessories, this digital apparatus does not exceed the Class A limits for radio noise emissions from digital apparatus set out in the Radio Interference Regulations of the Canadian Department of Communications.

VCCI Class A and B (Japan)

Class B

この装置は、情報処理装置等電波障害自主規制協議会(VCCI)の基準に基づくクラスB情報技術装置です。この装置は、家庭環境で使用することを目的としていますが、この装置がラジオやテレビジョン受信機に近接して使用されると、受信障害を引き起こすことがあります。取り扱い説明書に従って正しい取り扱いをして下さい。

Class A for LAN cables connection using print server accessory

注意

プリントサーバのアクセサリを使ってLANケーブルに接続されている場合、この装置は、情報処理装置等電波障害自主規制協議会(VCCI)の基準に基づくクラスA情報技術装置です。この装置を家庭環境で使用すると電波妨害を引き起こすことがあります。この場合には使用者が適切な対策を講ずるよう要求されることがあります。

Safety power cord warning

製品には、同梱された電源コードをお使い下さい。
同梱された電源コードは、他の製品では使用出来ません。

Chinese EMI statement

Class B

本设备符合中国无线电干扰技术标准信息技术设备B级发射限值要求。

Class A for LAN cables connection using print server accessory

当使用打印服务器附件与LAN电缆相连时，则本设备符合中国无线电干扰技术标准信息技术设备A级发射限值要求。

Korean EMI statement

사용자 안내문 : A 급 기기

이 기기는 업무용으로 전자파적합등록을 받은 기기이오니, 판매자 또는 사용자는 이 점을 주의 하시기 바라며, 만약 잘못 구입 하셨을 때에는 구입한 곳에서 비업무용으로 교환 하시기 바랍니다.

Taiwanese EMI statement

警告使用者: 這是甲類的資訊產品, 在居住的環境中使用時, 可能會造成射頻干擾, 在這種情況下, 使用者會被要求採取某些適當的對策。

Sound

Geräuschemission (Germany)

LpA < 70 dB, am Arbeitsplatz, im Normalbetrieb, nach DIN 45635 T. 19.

Address

Hewlett-Packard Company
Manager of Corporate Product Regulations
3000 Hanover Street
Palo Alto, CA 94304
650/857-1501

Declaration of conformity

According to ISO/IEC Guide 22 and EN 45014

Manufacturer's name: Hewlett-Packard Española S.A.
Supplier's address: Inkjet Commercial Division
Avenida Graells, 501
08174 Sant Cugat del Vallès
Barcelona, Spain

declares that the product

Regulatory Model Number⁴⁾: BCLAA-0604

Product Family: HP Designjet 5100 Series Inkjet Printers
HP Designjet 5500 Series Inkjet Printers

Product accessories: All

conforms to the following product specifications

Safety: IEC 60950-1:2001 / EN 60950-1:2001

EMC: CISPR 22:2005 / EN 55022:2006 Class B^{1) 3)}
EN 55024:1998 +A1:2001 +A2:2003
EN 61000-3-2:2000+A2:2005/ IEC 61000-3-2:2000+A2:2004
EN 61000-3-3:1995+A1:2001/ IEC 61000-3-3/A1:200
FCC Title 47 CFR, Part 15 Class B²⁾

Additional information

The product herewith complies with the requirements of the Low Voltage Directive 2006/95/EC and the EMC Directive 2004/108/EC and carries the CE-marking accordingly. In addition it complies with the WEEE Directive 2002/96/EC and RoHS Directive 2002/95/EC.

- 1** The product was tested in a typical configuration with HP Personal Computer Systems and peripherals
- 2** This Device complies with Part 15 of the FCC Rules. Operation is subject to the following two Conditions: (1) this device may not cause harmful interference, and (2) this device must accept any interference received, including interference that may cause undesired operation.
- 3** The product exhibits class A operation when connected to LAN cables using print server accessories.
- 4** This product is assigned a Regulatory Model Number which stays with the regulatory aspects of the design. The Regulatory Model Number is the main product identifier in the regulatory documentation and test reports, this number should not be confused with the marketing name or the product numbers.

Vicenç Llorens
Product Regulations Manager
Sant Cugat del Vallès (Barcelona),
January 30th, 2008



Local contact for regulatory topics only

EMEA Contact: Hewlett-Packard GmbH, HQ-TRE, Herrenberger Strasse
140, 71034 Boeblingen, Germany

USA Contact: Hewlett-Packard Company, Corporate Product Regulations
Manager, 3000 Hanover St, Palo Alto, CA 94304, USA . Phone: (650) 857
1501.

Australia Contact: Hewlett-Packard Australia Ltd, Product regulations
Manger, 31-41 Joseph Street, Blackburn, Victoria,3130, Australia

Energy Star information

This document substitutes any information regarding the Energy Star US EPA's program mentioned in any of the user manuals provided along with this product.

To determine the ENERGY STAR® qualification status of this product, consult:

<http://www.hp.com/go/energystar>

ENERGY STAR and ENERGY STAR trademark are registered U.S. trademarks.

Disposal of waste equipment by users in private households in the European Union



This symbol on the product or on its packaging indicates that this product must not be disposed of with your other household waste. Instead, it is your responsibility to dispose of your waste equipment by handing it over to a designated collection point for the recycling of waste electrical and electronic equipment. The separate collection and recycling of your waste equipment at the time of disposal will help to conserve natural resources and ensure that it is recycled in a manner that protects human health and the environment. For more information about where you can drop off your waste equipment for recycling, please contact your local city office, your household waste disposal service or the shop where you purchased the product.

Attention California users

The battery supplied with this product may contain perchlorate material. Special handling may apply. See <http://www.dtsc.ca.gov/hazardouswaste/perchlorate/> for information.

Atención a los usuarios de California

La pila proporcionada con este producto puede contener perclorato. Podría requerir manipulación especial. Consulte <http://www.dtsc.ca.gov/hazardouswaste/perchlorate/> para obtener más información.



© 2007 Hewlett-Packard Development Company L.P.

Printed in Germany - Imprimé en Allemagne - Stampato in Germania

www.hp.com

