

HP xb4 Notebook Media Docking Station

Maintenance and Service Guide

Document Part Number: 463777-001

October 2008

This guide is a troubleshooting reference used for maintaining and servicing the docking station. It provides comprehensive information on identifying product features, components, and spare parts; troubleshooting docking station problems; and performing basic disassembly procedures.

© Copyright 2008 Hewlett-Packard Development Company, L.P.

Windows is a U.S. registered trademarks of Microsoft Corporation. SD Logo is a trademark of its proprietor.

The information contained herein is subject to change without notice. The only warranties for HP products and services are set forth in the express warranty statements accompanying such products and services. Nothing herein should be construed as constituting an additional warranty. HP shall not be liable for technical or editorial errors or omissions contained herein.

First Edition: October 2008

Document Part Number: 463777-001

Safety warning notice



WARNING: To reduce the possibility of heat-related injuries or of overheating the computer, do not place the computer directly on your lap or obstruct the computer air vents. Use the computer only on a hard, flat surface. Do not allow another hard surface, such as an adjoining optional printer, or a soft surface, such as pillows or rugs or clothing, to block airflow. Also, do not allow the AC adapter to contact the skin or a soft surface, such as pillows or rugs or clothing, during operation. The computer and the AC adapter comply with the user-accessible surface temperature limits defined by the International Standard for Safety of Information Technology Equipment (IEC 60950).

Contents

1 Product description

Compatibility	1-1
Features	1-2
Expansion port features	1-2
External components	1-3
Front components	1-3
Bottom components	1-4
Rear components	1-5
Right-side components	1-6
Left-side components	1-7
Wireless accessories	1-7
Design overview	1-8
Using the docking station	1-9
Adjusting the docking station	1-9
Connecting to AC power	1-10
Docking the computer	1-12

2 Troubleshooting

Troubleshooting checklist	2-1
Problems and solutions	2-1
General use and connection problems	2-2
Audio problems	2-2
Video problems	2-3
Getting more information	2-3

3 Illustrated parts catalog

Serial number location	3-1
Docking station	3-2
Wireless components	3-2
Hard drive adapter	3-3
Power cords (not illustrated)	3-3
Sequential part number listing	3-3

4 Removal and replacement procedures

Preliminary replacement requirements	4-1
Component replacement procedures	4-2
Serial number	4-2
Installing an optional hard drive	4-3
Installing an HP Pocket Media Drive and HP Pocket Media Drive Adapter	4-5

5 Specifications

6 Connector pin assignments

Audio-in (microphone)	6-1
Audio-out (headphone)	6-1
Cable docking connector	6-2
External monitor	6-3
RJ-45 (network)	6-4
Universal Serial Bus	6-4

7 Power cord set requirements

Requirements for all countries and regions	7-1
Requirements for specific countries and regions	7-2
3-Conductor power cord set requirements	7-2

Index

Product description

The HP xb4 Notebook Media Docking Station provides an efficient, less-cluttered work environment, improved cable management, and wireless peripherals. It eliminates the need to purchase a separate monitor, external speakers, USB hub, and a wireless keyboard and mouse kit.



The wireless keyboard and mouse kit are available in select countries and regions.



Compatibility

The docking station is compatible with all HP and Compaq notebooks having a USB 2.0 port.

Features

- Adjustable height
- Support for display panel sizes up to 43 cm (17 inches) wide
- Bottom-mounter sub-woofer speakers
- Wireless keyboard, mouse, receiver (select models only)
- Hard drive bay and power connector
- Infrared pass-through support
- Lights (power, good dock, mute)
- Volume control
- Allows use of iPod or MP3 player with its sound system
- Can control your home entertainment audio system
- Connectors:
 - Expansion cable
 - Audio-out (headphone) jack
 - Audio-in (microphone) jack
 - Universal Serial Bus (USB) 2.0 connectors (6)
 - Power connector
 - Component video jacks
 - S-Video-out jack
 - Composite video jack
 - S/PDIF (Sony/Philips Digital Interface) audio jack
 - External VGA monitor port
 - RJ-45/Ethernet port
 - Hard drive power connector

Expansion port features

- USB 2.0
- Gigabit Ethernet
- Consumer infrared (for optional remote control only)
- Power inputs (16 W to 90 W maximum)
- Headphone/speaker audio-out
- Microphone audio-in
- VGA
- Power button
- Volume control (up/down)
- Mute/unmute status

External components

Front components

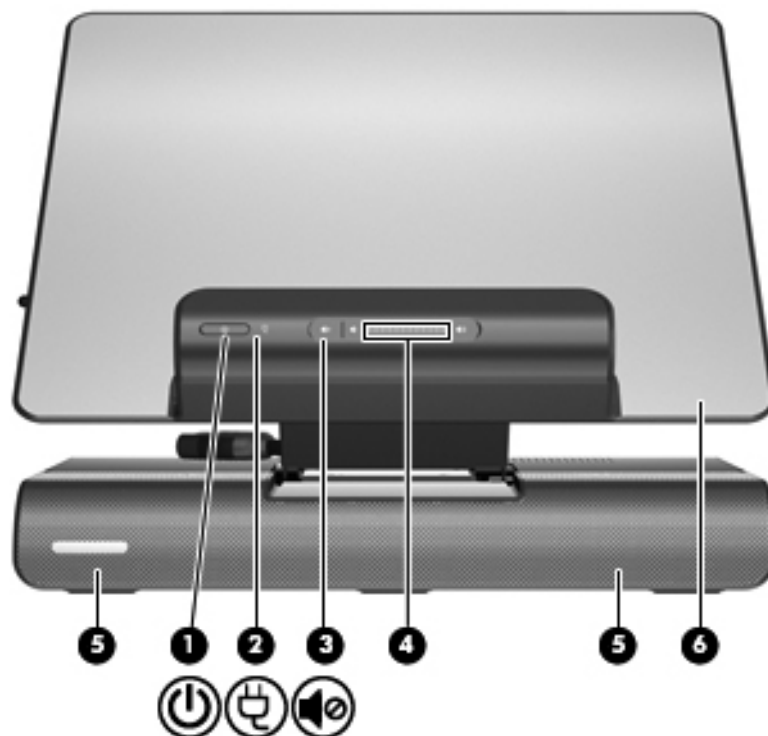

Item	Component	Function
❶	Power button	Turns on the docked computer, and initiates or exits Hibernation and Standby. After the computer is docked, the power button on the docking station acts like the computer power button, using the computer management settings.
❷	Power status light	On: The docking station is on.
❸	Volume mute button	Mutes and restores speaker sound.
❹	Volume scroll zone	Adjusts speaker volume. Slide your finger to the left to decrease volume and to the right to increase volume. You can also tap the minus sign on the scroll zone to decrease volume, or tap the plus sign on the scroll zone to increase volume.
❺	Speakers (2)	Produce stereo docking station sound.
❻	Upper panel	Holds the docked computer.

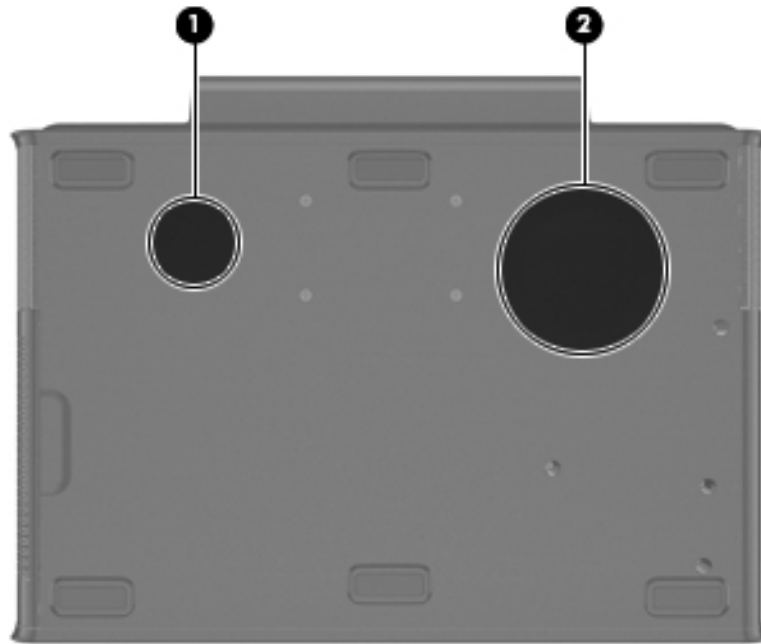

Bottom components



Item	Component	Function
❶	Vent	Enables airflow to cool internal components.
❷	Subwoofer	Produces low audio-frequency sound.

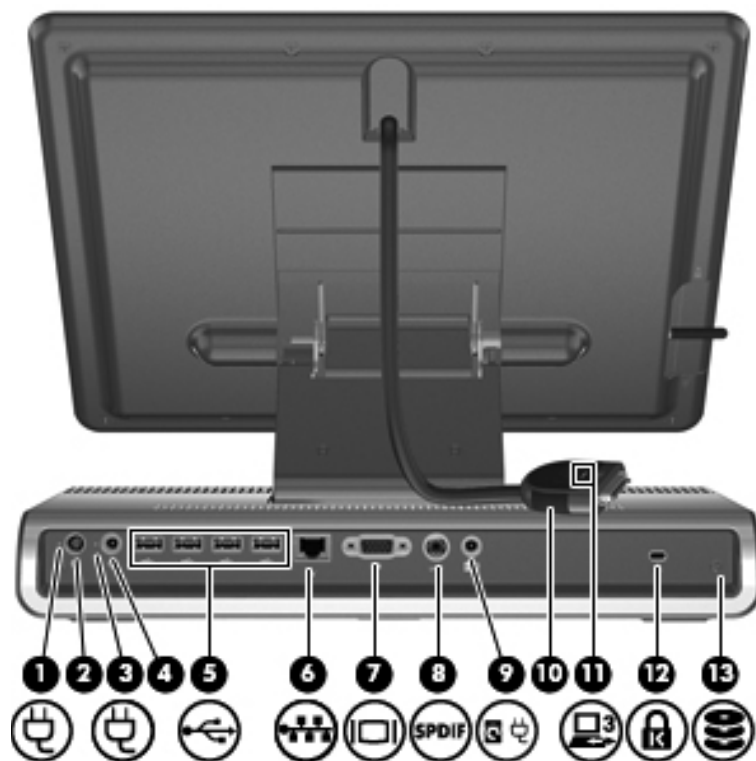



Rear components



Item	Component	Function
❶	Power connector 1 light	On: The docking station is connected to AC power.
❷	Power connector 1	Connects the docking station to a Smart AC adapter.
❸	Power connector 2 light	On: The docking station is connected to AC power.
❹	Power connector 2	Connects the docking station to a standard AC adapter.
❺	USB ports (4)	Connect optional USB device. Power is always on to all USB ports when the docking station is connected to AC power.  There are 2 additional USB ports on the right panel of the docking station.
❻	RJ-45 (network) jack	Connects an Ethernet network cable.
❼	External VGA monitor port	Connects an optional external VGA monitor or projector.
❽	S/PDIF (Sony/Philips Digital Interface) digital audio jack	Connects an optional compatible audio/video receiver through a digital control cable (purchased separately).
❾	Hard drive power connector	Connects an optional HP Personal Media Drive to dedicated external AC power.
❿	Expansion cable	Docks a computer.
⓫	Good dock connection light	On: The computer is correctly docked.
⓬	Security cable slot	Attaches an optional security cable to the docking station.  The security cable is designed to act as a deterrent, but it may not prevent the docking station from being mishandled or stolen.
⓭	Hard drive security screw	Secures the hard drive carrier for the optional internal hard drive.

Right-side components



Item	Component	Function
❶	PC port	<p>The (USB type B) PC port connects an optional secondary computer to the docking station.</p> <p> Do not use the PC port as a printer connection.</p>
❷	Auxilliary audio jack	<p>Connects an optional MP3 player or other audio device to docking station speakers.</p>
❸	Audio-out (headphone) jack	<p>Produces sound when connected to optional external powered stereo speakers, headphones, ear buds, a headset, or television audio.</p> <p> The speakers are muted when a device is connected to the telephone jack.</p>
❹	Audio-in (microphone) jack	<p>Connects an optional computer headset microphone, stereo array microphone, or monaural microphone.</p> <p>Connects the microphone to the audio-in (microphone) jack on the docking station when a computer is docked.</p> <p> The docked computer microphone settings may need to be changed before you connect a microphone to the audio-in (microphone) jack on the docking station. Refer to your Windows® operating system instructions for more information.</p> <p> For specific microphone usage information, refer to the microphone manufacturer's instructions.</p>
❺	USB ports (2)	<p>Connect optional USB devices.</p> <p>Power is always on to all USB ports when the docking station is connected to AC power.</p> <p> There are 4 additional USB ports on the rear panel of the docking station.</p>

Left-side components

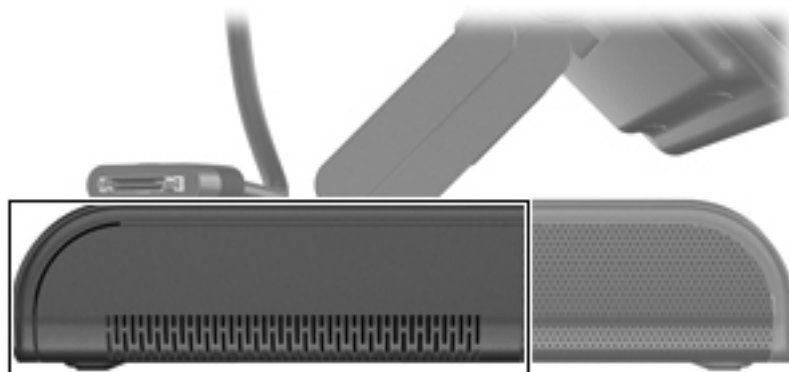

Component	Description
Hard drive bay	Holds an optional internal HP Personal Media Drive or HP Pocket Media Drive.

Wireless accessories



Item	Component	Description
①	Wireless keyboard	Connects to the docking station without a cable.
②	Wireless mouse (with receiver)	Connects to the docking station without a cable.

Design overview

This section presents a design overview of key parts and features of the docking station. To identify replacement parts, refer to “[Chapter 3, “Illustrated parts catalog.”](#)”

The docking station provides the following device connections:

- Expansion cable
- S/PDIF (Sony/Philips Digital Interface) audio jack
- Audio-out (headphone) jack
- Audio-in (microphone jack
- Auxiliary audio-in jack
- Hard drive power connector
- IR device
- PC port
- RJ-45 (network) jack
- USB 2.0 ports (6)
- External VGA monitor port

Using the docking station

Adjusting the docking station

The upper panel on the docking station must be raised before a computer can be docked. To raise the upper panel:

1. Lower the lever **1** located on the left side of the upper panel to the down position.
2. Grasp the upper panel **2** with both hands, and lift the panel toward you.
3. Lift the lever **3** to the up position to lock the upper panel position.



To lower the upper panel:

1. Lower the lever ❶ located on the left side of the upper panel to the down position.
2. Grasp the upper panel ❷ with both hands, and tilt the upper panel down.
3. Lift the lever ❸ to the up position to lock the upper panel position.

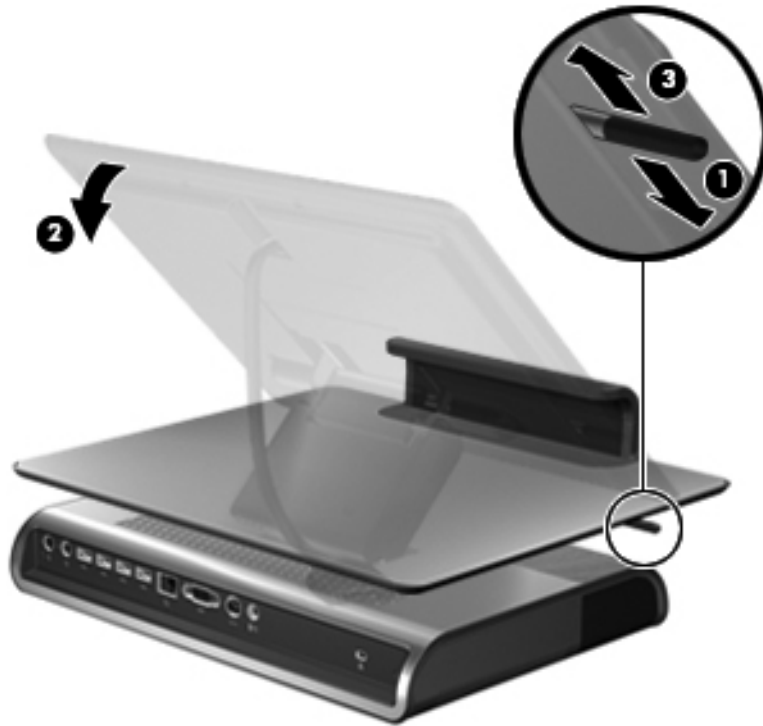

Connecting to AC power



WARNING: To reduce the risk of electric shock or damage to your equipment:

Plug the power cord into an AC outlet that is easily accessible at all times.

Disconnect power from the product by unplugging the power cord from the AC outlet.

If provided with a 3-pin attachment plug on the power cord, plug the cord into a grounded (earthed) 3-pin outlet. Do not disable the power cord grounding pin, for example, by attaching a 2-pin adapter. The grounding pin is an important safety feature. It is possible to receive an electric shock from a system that is not properly grounded.



Both a smart AC power connector and a standard AC power connector are provided. Choose the connector that corresponds to the computer AC power adapter being used.

Connect the docking station to an AC power source using the computer AC adapter and power cord.

1. Identify the correct power connector to the docking station.

 Power cords and AC outlets vary in appearance by region and country. The AC adapter is included with the computer or purchased separately.

2. Connect the computer AC adapter to the corresponding power connector on the docking station **1**.

Connect a smart AC adapter to the corresponding power connector **1**.

– or –

Connect a standard AC adapter to the corresponding power connector **1**.

3. Connect the AC power cord to the AC adapter **2**.

4. Connect the AC power cord to the AC outlet **3**.



Docking the computer

1. Open the computer.



2. Slide the computer into the docking station with the keyboard facing you.



The computer is held in place by a buffer pad, which prevents the computer from shifting out of position.

3. Move the expansion cable to either side of the docking station, depending on where the expansion port on your computer is located.





The location of the expansion port on your computer varies by computer series and model.



It is important to position the cable correctly, so that the cable can move freely.

4. Press and hold the buttons on the sides of the expansion cable connector ❶.
5. Connect the expansion cable to the expansion port on the computer ❷, matching the icon on the computer expansion port with the icon on the end of the expansion cable.

 **CAUTION:** To prevent damage to the expansion port, be sure that you correctly align the expansion cable with the expansion port on the computer.

 The expansion port may also be called *expansion port 3* in the computer documentation.



If the computer is already on, the good dock connection light on the expansion cable turns on.



- If the computer is off, press the power button on the docked computer or the power button on the docking station.



The power button location on the docked computer varies by computer series and model.



The power status light on the front of the docking station turns on.



After the computer is docked, the internal computer speakers are disabled and the docking station speakers are activated.

Troubleshooting



WARNING: Only authorized technicians trained by HP should repair this equipment. All troubleshooting and repair procedures are detailed to allow only subassembly-/module-level repair. Because of the complexity of the individual boards and subassemblies, do not attempt to make repairs at the component level or modifications to any printed wiring board. Improper repairs can create a safety hazard. Any indication of component replacement or printed wiring board modification may void any warranty or exchange allowances.

This chapter contains troubleshooting information for the docking station. Carefully match the symptoms of the malfunction against the problem description in the troubleshooting tables to avoid a misdiagnosis. Refer to [Chapter 4, “Removal and replacement procedures,”](#) for all removal and replacement procedures.

Follow these guidelines when troubleshooting:

- Complete the recommended actions in the order in which they are given.
- When the problem is resolved, do not complete the remaining troubleshooting steps.

Troubleshooting checklist

When troubleshooting a problem, check the following list for possible solutions before replacing parts:

- Be sure that cables are connected properly to the suspected defective part.
- Be sure that all required device drivers are installed.

Problems and solutions

The following tables list possible problems, the possible cause of each problem, and the recommended solution.

General use and connection problems

Problem	Possible cause	Solution
The connection indicator light is not on.	The computer is not powered on.	Turn on the computer.
	The docking station is not connected to AC power.	Connect the AC adapter to the docking station and to an AC outlet.
	The expansion cable on the docking station is not fully connected to the expansion port on the computer.	Disconnect the expansion cable from the computer, and then reconnect the cable to the expansion port on the computer.
The computer shuts down unexpectedly.	The computer is in Sleep, Standby, or Hibernation.	Exit Sleep, Standby, or Hibernation.
	The docking station is not connected to AC power, draining the computer battery.	Connect the AC adapter to the docking station and to an AC outlet.
The docked computer cannot access docking station USB devices.	A secondary computer is connected to the docking station PC port.	Disconnect the secondary computer.
The ports or jacks on the docking station are not working.	The docking station is not connected to AC power.	Connect the AC adapter to the docking station and to an AC outlet.
	The computer is not docked correctly.	Redock the computer.
The optional wireless keyboard or mouse does not work.	The wireless receiver is not connected to a USB port.	Connect the wireless receiver to a USB port.
	The wireless receiver and keyboard or mouse have not been synchronized.	Synchronize the devices by pressing the appropriate buttons.
	The wireless keyboard or mouse has no battery power.	Be sure that batteries are inserted correctly in the wireless keyboard or mouse and that the batteries are functional.

Audio problems

Problem	Possible cause	Solution
The docking station speakers have little or no volume.	The docking station speakers have been muted or the volume is set too low.	Adjust the volume using the volume scroll zone.
	The docking station is not connected to AC power.	Connect the AC adapter to the docking station and to an AC outlet.
	An audio device is connected to the headphone jack of the docking station or computer, muting the docking station speakers.	Unplug the audio device.
	The computer is not docked correctly.	Redock the computer.
The volume level does not increase or decrease.	The volume scroll zone is not being used correctly.	To increase volume, slide your finger from left to right on the volume scroll zone, or tap the plus sign. To decrease volume, slide your finger from right to left on the volume scroll zone, or tap the minus sign.
Media from the docked computer or docking station hard drive will not play.	There is an auxiliary audio device connected to the docking station.	Disconnect the auxiliary audio device.

(Continued)

Problem	Possible cause	Solution
An audio device connected to the docking station does not produce sound.	An audio device is connected to the headphone jack on the computer. Using the headphone jack on the computer mutes the docking station sound.	Disconnect the audio device from the headphone jack on the computer.
A microphone connected to the computer does not work.	A microphone is connected to the docking station.	Either use the microphone connected to the docking station or disconnect it.
A connected home entertainment system does not have audio.	Audio is not connected properly.	Be sure that the docking station is properly connected to the home entertainment system.
A connected home entertainment system does not experience surround sound.	The home entertainment system may not support digital audio.	Be sure that your home entertainment system is S/PDIF compatible.

Video problems

Problem	Possible cause	Solution
A connected home entertainment system does not have video.	The video cable is not connected correctly.	Disconnect and reconnect the video cable.
	The screen image is displaying on the computer.	Press fn-f4 on the computer to switch the image from the computer to the external display.
	The docking station is not connected to AC power.	Connect the AC adapter to the docking station and to an AC outlet.
	The computer is not docked correctly.	Redock the computer.

Getting more information

- For comprehensive information about your computer, as well as government agency and safety information about the use of your computer, access Help and Support by selecting **Start > Help and Support**.
- The HP Web site (<http://www.hp.com>) provides product news and software updates.

Serial number location

When ordering parts or requesting information, provide the docking station serial number and model number located on the bottom of the docking station.

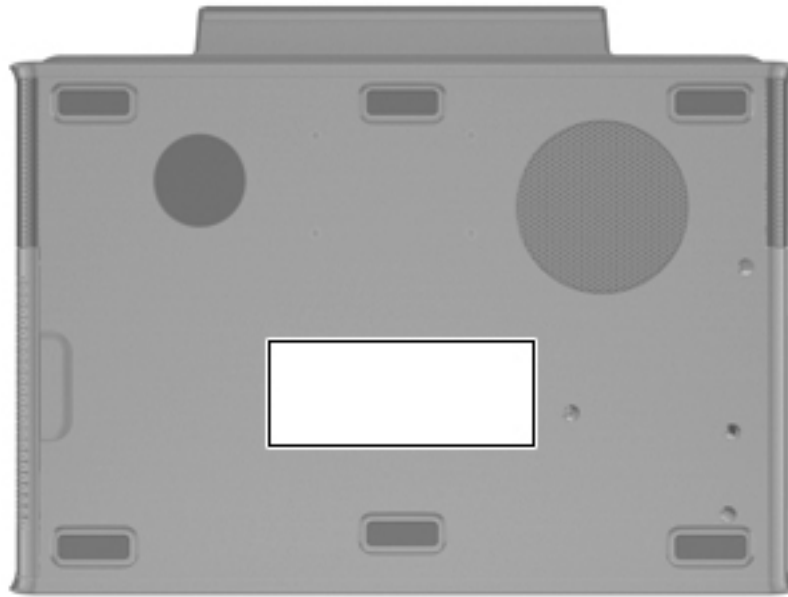

Docking station



Description	Spare Part Number
HP xb4 Docking Station (whole unit replacement)	481018-001

Wireless components



Item	Description	Spare part number
❶	Wireless USB keyboard (U.S.)	481019-001
	Wireless USB keyboard (Brazil)	481019-201
	Wireless USB keyboard (Latin America)	481019-161
	Wireless USB keyboard (South Korea)	481019-AD1
	Wireless USB keyboard (Asia/Pacific, English)	481019-009
❷	Wireless mouse (with receiver)	480975-001

Hard drive adapter



Description	Spare Part Number
Mini hard drive adapter	481562-001

Power cords (not illustrated)

Description	Spare Part Number
Refer to the spare parts list for your computer	

Sequential part number listing

Description	Spare Part Number
Wireless mouse (with receiver)	480975-001
HP xb4 Docking Station (whole unit replacement)	481018-001
Wireless USB keyboard (U.S.)	481019-001
Wireless USB keyboard (Asia/Pacific, English)	481019-009
Wireless USB keyboard (Latin America)	481019-161
Wireless USB keyboard (Brazil)	481019-201
Wireless USB keyboard (South Korea)	481019-AD1
Mini hard drive adapter	481562-001

Removal and replacement procedures

Preliminary replacement requirements

Plastic parts

Using excessive force during disassembly and reassembly can damage plastic parts. Use care when handling the plastic parts. Apply pressure only at the points designated in the maintenance instructions.

Cables and connectors



CAUTION: When servicing the docking station, be sure that cables are placed in their proper locations during the reassembly process. Improper cable placement can damage the docking station or the attached computer.

Cables must be handled with extreme care to avoid damage. Apply only the tension required to unseat or seat the cables during removal and insertion. Handle cables by the connector whenever possible. In all cases, avoid bending, twisting, or tearing cables. Be sure that cables are routed in such a way that they cannot be caught or snagged by parts being removed or replaced. Handle flex cables with extreme care; these cables tear easily.

Component replacement procedures

The docking station is whole unit replacement item and the only spare part that requires removal and installation is the mini hard disk drive adapter.

Serial number

Report the docking station serial number to HP when requesting information or ordering spare parts. The serial number is located on the bottom of the docking station. The table below identifies the key information that you need when contacting HP for replacement parts or for service-related questions. Each component identified appears on the label on the bottom of the unit.

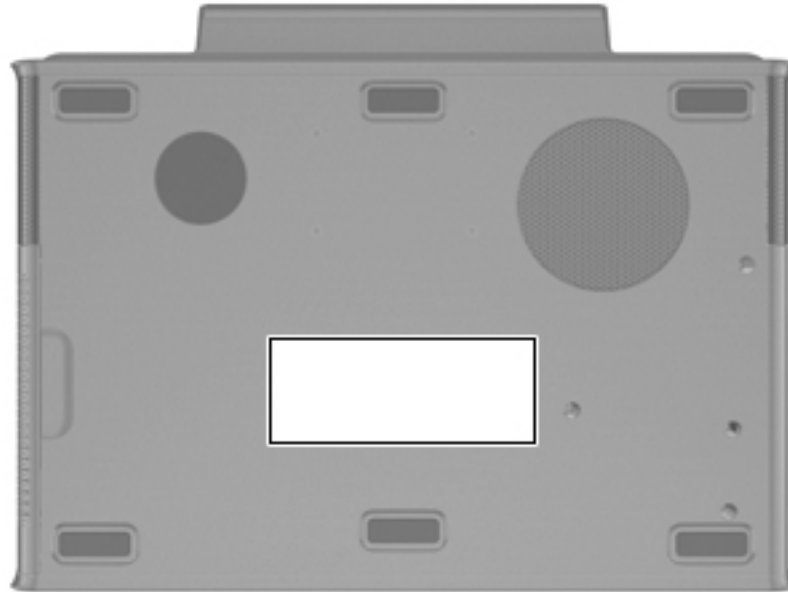

Component	Description
Product name	This is the product name affixed to the front of your computer.
Serial number (s/n)	This is an alphanumeric identifier that is unique to each product.
Part number/ product number (p/n)	This number provides specific information about the product's hardware components. The part number helps a service technician to determine what components and parts are needed.
Model description	This is the number you use to locate documents, drivers, and support for your docking station.
Warranty period	This number describes the duration (in years) of the warranty period for this computer.

Installing an optional hard drive

Installing an HP Personal Media Drive



You can insert a Personal Media Drive (PMD) into the docking station for extra storage capacity.

1. Remove the hard drive security screw ❶ on the rear panel of the docking station and remove the hard drive cover ❷ from the hard drive bay.



CAUTION: To reduce the possibility of damaging the hard drive cover, grasp the hard drive cover from the bottom to remove it.

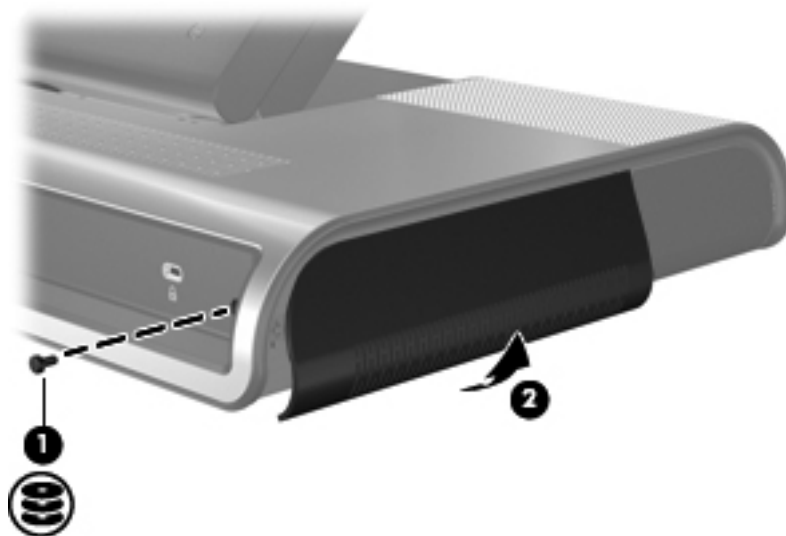

2. Insert the hard drive ❶ into the hard drive bay until the drive is fully seated.

 If the hard drive light ❷ does not turn on, reseal the hard drive.

3. Replace the hard drive security screw ❸.

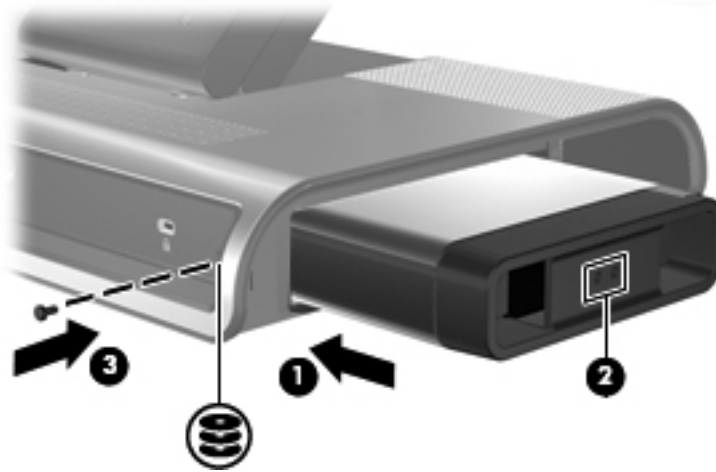

4. Connect the hard drive to dedicated external AC power.



WARNING: To reduce the risk of electric shock or damage to your equipment:

- Plug the power cord into an AC outlet that is easily accessible at all times.
- Disconnect power from the product by unplugging the power cord from the AC outlet.
- If provided with a 3-pin attachment plug on the power cord, plug the cord into a grounded (earthed) 3-pin outlet. Do not disable the power grounding pin, for example, by attaching a 2-pin adapter. The grounding pin is an important safety feature. It is possible to receive an electric shock from a system that is not properly grounded.

a. Connect the hard drive AC adapter to the hard drive power connector ❶ on the docking station.

b. Connect the power cord to the AC adapter ❷.

c. Connect the power cord to an AC outlet ❸.

 Power cords and AC outlets vary in appearance by region and country.

For more information on the hard drive, refer to the instructions that were included with the drive.

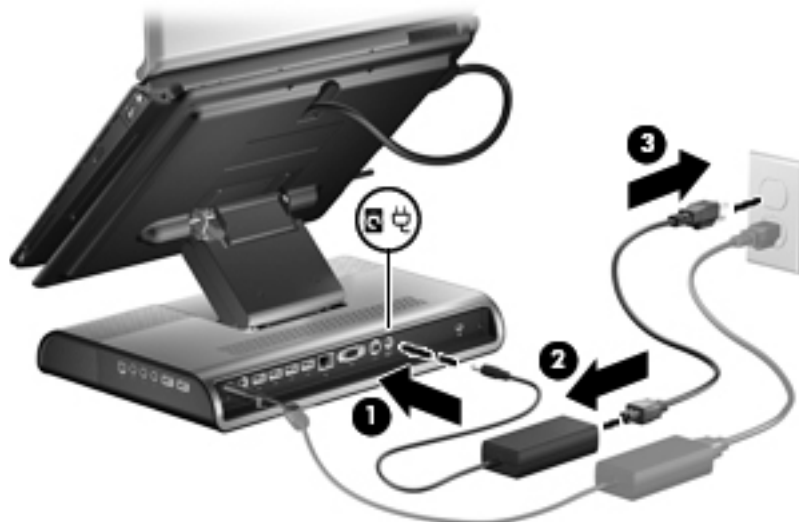

5. To remove the drive, reverse the installation procedure.

Installing an HP Pocket Media Drive and HP Pocket Media Drive Adapter



WARNING: To reduce the risk of electric shock or damage to your equipment:

- Plug the power cord into an AC outlet that is easily accessible at all times.
- Disconnect power from the product by unplugging the power cord from the AC outlet.
- If provided with a 3-pin attachment plug on the power cord, plug the cord into a grounded (earthed) 3-pin outlet. Do not disable the power grounding pin, for example, by attaching a 2-pin adapter. The grounding pin is an important safety feature. It is possible to receive an electric shock from a system that is not properly grounded.

1. Disconnect the docking station from AC power.
2. Remove the hard drive security screw ❶ on the rear panel of the docking station and remove the hard drive cover ❷ from the hard drive bay.



CAUTION: To reduce the possibility of damaging the hard drive, grasp the hard drive cover from the bottom to remove it.

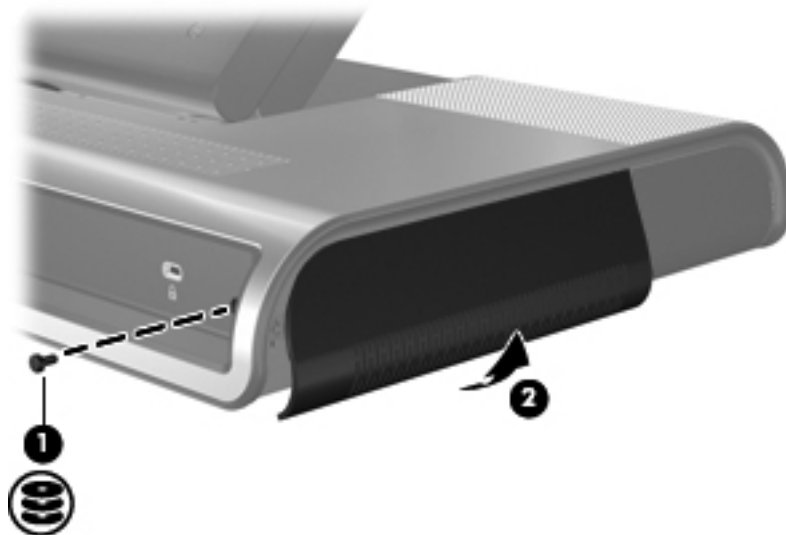

3. Insert the drive adapter ❶ into the hard drive bay until the adapter is fully seated.
4. Replace the hard drive security screw ❷.
5. Reconnect the docking station to AC power.

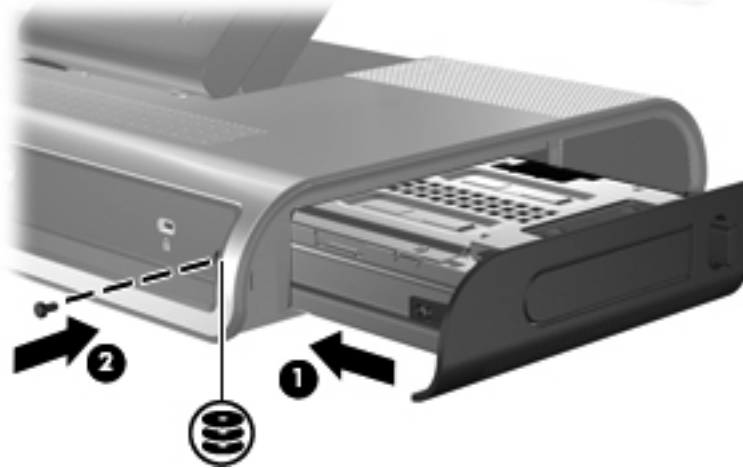

6. Insert the drive ❶ into the adapter until the drive is fully seated.

 If the hard drive light ❷ does not turn on, reseal the hard drive.

For more information on the PMD, refer to the instructions that were included with the kit.

7. To remove the drive, press the eject button ❸ on the front of the adapter.

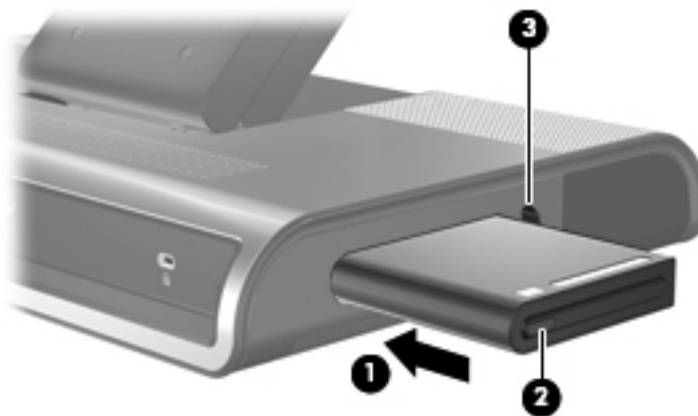

Specifications

This table provides physical and performance specifications for the docking station.

	Metric	U.S.
Dimensions		
Length	35.7 cm	14.1 in
Width	30.3 cm	11.9 in
Height	18.7 cm	7.4 in
Weight		
With 2.5" PMD	5.54 kg	12.2 lb
With 3.5" PMD	5.05 kg	11.1 lb
Temperature		
Operating	10°C to 35°C	50°F to 95°F
Nonoperating	-20°C to 60°C	-4°F to 140°F
 Applicable product safety standards specify thermal limits for plastic surfaces. The expansion base operates well within this range of temperatures.		
Relative humidity (noncondensing)		
Operating	10% to 90%	
Nonoperating	5% to 95%, 38.7°C (101.6°F) maximum wet bulb temperature	

This table provides physical and performance specifications for the hard drive.

Dimensions		Logical geometry	
Height	25.4 mm	Cylinders	16,383
Width	89 mm	Heads	16
Weight	499 g	Sectors	63
Interface type	AT 16 bit	Total logical sections	2,001,382
Data transfer rate		Disk rotational speed	
Disk to buffer	45 Mbytes/sec		7200 rpm
Interface with or with IORDY	16.6 Mbytes/sec		
Seek times (typical read, including setting)		Average latency	
			5.5 ms
Single track	3 ms	Spin-up time (maximum)	
Average	13 ms		7.0 s
Maximum	24 ms		
Physical geometry		Spin-down time (maximum)	
Cylinders	158,518		100 S
Heads	4		
Sectors	ID 528-710 OD 998-1216		
Operating temperature		5°C to 55°C (41°F to 131°F)	



Certain restrictions and exclusions apply. Consult Help and Support for details.

*Total storage capacity is 300 billion bytes (for hard drives, 1GB = 1 billion bytes); actual accessible capacity is less. Actual drive specifications may differ slightly.

Connector pin assignments

Audio-in (microphone)

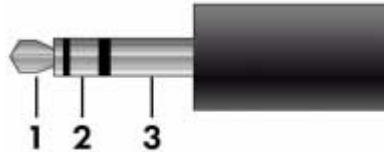

Pin	Signal
1	Audio signal in
2	Audio signal in
3	Ground

Audio-out (headphone)

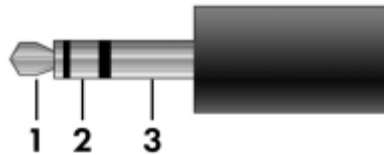

Pin	Signal
1	Audio out, left channel
2	Audio out, right channel
3	Ground

Cable docking connector

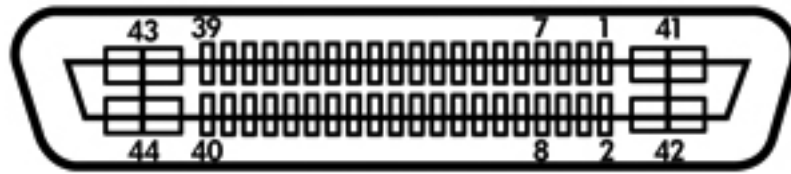

Pin	Signal	Pin	Signal
1	Dock present	23	Sleep Button
2	Battery out	24	Digital Ground
3	Microphone ground	25	Mute_LED
4	Battery out	26	Vsync
5	Microphone Left	27	PWR_ON
6	MDI0-	28	USB-
7	Microphone Right	29	CIR Input
8	MDI0+	30	DDC Clock
9	Left headphone	31	TV ground
10	MDI1-	32	Hsync
11	Right headphone	33	TV composite
12	MDI1+	34	CRT_Blue
13	Audio Output ground	35	TV chrome
14	MDI2-	36	DDC_DATA
15	S/PDIF	37	TV Luma
16	MDI2+	38	CRT_Red
17	Vol_down	39	Digital Ground
18	MDI3-	40	CRT_Green
19	Vol_UP	41	VSS-
20	MDI3+	42	VSS-
21	Jaco Detect	43	VDC+
22	USB+	44	VDC+

External monitor

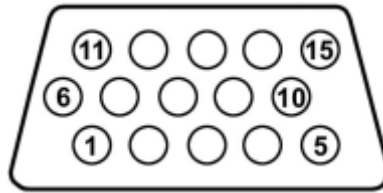

Pin	Signal
1	Red analog
2	Green analog
3	Blue analog
4	Not connected
5	Ground
6	Ground analog
7	Ground analog
8	Ground analog
9	+5 VDC
10	Ground
11	Monitor detect
12	DDC 2B data
13	Horizontal sync
14	Vertical sync
15	DDC 2B clock

RJ-45 (network)

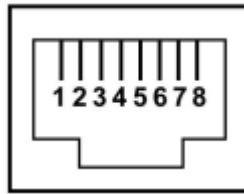

Pin	Signal
1	Transmit +
2	Transmit
3	Receive +
4	Unused
5	Unused
6	Receive -
7	Unused
8	Unused

Universal Serial Bus

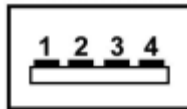

Pin	Signal
1	+5 VDC
2	Data -
3	Data +
4	Ground

Power cord set requirements

The wide range input feature of the computer permits it to operate from any line voltage from 100 to 120 volts AC or from 220 to 240 volts AC.

The 3-conductor power cord set included with the computer meets the requirements for use in the country or region where the equipment is purchased.

Power cord sets for use in other countries and regions must meet the requirements of the country or region where the computer is used.

Requirements for all countries and regions

The requirements listed below are applicable to all countries and regions:

- The length of the power cord set must be at least 1.5 m (5.0 ft) and no more than 2.0 m (6.5 ft).
- All power cord sets must be approved by an acceptable accredited agency responsible for evaluation in the country or region where the power cord set will be used.
- The power cord sets must have a minimum current capacity of 10 amps and a nominal voltage rating of 125 or 250 V AC, as required by the power system of each country or region.
- The appliance coupler must meet the mechanical configuration of an EN 60 320/IEC 320 Standard Sheet C13 connector for mating with the appliance inlet on the back of the computer.

Requirements for specific countries and regions

3-Conductor power cord set requirements

Country/region	Accredited agency	Applicable note number
Australia	EANSW	1
Austria	OVE	1
Belgium	CEBC	1
Canada	CSA	2
Denmark	DEMKO	1
Finland	FIMKO	1
France	UTE	1
Germany	VDE	1
Italy	IMQ	1
Japan	METI	3
The Netherlands	KEMA	1
Norway	NEMKO	1
The People's Republic of China	CCC	5
South Korea	EK	4
Sweden	SEMKO	1
Switzerland	SEV	1
Taiwan	BSMI	4
The United Kingdom	BSI	1
The United States	UL	2

1. The flexible cord must be Type HO5VV-F, 3-conductor, 1.0-mm² conductor size. Power cord set fittings (appliance coupler and wall plug) must bear the certification mark of the agency responsible for evaluation in the country or region where it will be used.
2. The flexible cord must be Type SPT-3 or equivalent, No. 18 AWG, 3-conductor. The wall plug must be a two-pole grounding type with a NEMA 5-15P (15 A, 125 V) or NEMA 6-15P (15 A, 250 V) configuration.
3. The appliance coupler, flexible cord, and wall plug must bear a "T" mark and registration number in accordance with the Japanese Dentori Law. The flexible cord must be Type VCT or VCTF, 3-conductor, 1.00-mm² conductor size. The wall plug must be a two-pole grounding type with a Japanese Industrial Standard C8303 (7 A, 125 V) configuration.
4. The flexible cord must be Type RVV, 3-conductor, 0.75-mm² conductor size. Power cord set fittings (appliance coupler and wall plug) must bear the certification mark of the agency responsible for evaluation in the country or region where it will be used.
5. The flexible cord must be Type VCTF, 3-conductor, 0.75-mm² conductor size. Power cord set fittings (appliance coupler and wall plug) must bear the certification mark of the agency responsible for evaluation in the country or region where it will be used.

A

- accessories, wireless 1–7
- audio
 - audio-in jack pin assignments 6–1, 6–3
 - audio-out jack pin assignments 6–1
 - auxilliary jack 1–6
 - S/DPIF jack 1–5
- audio problems 2–2
- auxilliary audio jack 1–6

B

- bottom components 1–4
- button
 - power 1–3
 - volume mute 1–3

C

- cable docking connector pin assignments 6–2
- cables, service considerations 4–1
- components
 - bottom 1–4
 - front 1–3
 - right-side 1–6
- components, left-side 1–7
- connection problems 2–2
- connectors, service considerations 4–1

D

- docking station part number 3–2, 3–3
- drive bay, hard drive 1–7

E

- expansion cable 1–5
- expansion port features 1–2
- external monitor port pin assignments 6–3

F

- features 1–2
- front components 1–3

G

- general use problems 2–2
- good dock connection light 1–5

H

- hard drive adapter, part number 3–3
- hard drive bay 1–7

- hard drive power connector 1–5
- hard drive security screw 1–5
- headphone jack pin assignments 6–1

L

- left-side components 1–7
- light
 - good dock connection 1–5
 - power connector 1 1–5
 - power connector 2 1–5
 - power status 1–3

M

- microphone jack pin assignments 6–1
- model name 4–2
- monitor port 1–5
- monitor port pin assignments 6–3

N

- network jack 1–5
- network jack pin assignments 6–4

P

- panel, upper 1–3
- part number
 - docking station 3–2, 3–3
 - hard drive adapter 3–3
 - pocket media drive 3–3
 - wireless keyboard 3–2
 - wireless mouse 3–2
- PC port 1–6
- Personal Media Drive installation 4–3
- pin assignments
 - audio-in 6–1
 - audio-out 6–1
 - cable docking connector 6–2
 - external monitor port 6–3
 - headphone 6–1
 - microphone 6–1
 - monitor port 6–3
 - network 6–4
 - RJ-45 6–4
 - USB port 6–4
- plastic parts 4–1

- pocket media drive
 - installation 4–5
 - part number 3–3
- power button 1–3
- power connector 1 1–5
- power connector 1 light 1–5
- power connector 2 1–5
- power connector 2 light 1–5
- power connector, hard drive 1–5
- power cord set requirements 7–1
- power status light 1–3

problems

- audio 2–2
- connection 2–2
- general use 2–2
- video 2–3

- product name 4–2

R

- rear components 1–5
- removal/replacement procedures 4–2
- right-side components 1–6
- RJ-45 jack
 - location 1–5
 - pin assignments 6–4

S

- S/PDIF jack 1–5
- scroll zone volume control 1–3
- security cable slot 1–5
- security screw 1–5
- serial number location 3–1, 4–2
- speaker location 1–3, 1–4
- specifications 5–1
- subwoofer location 1–4

U

- upper panel 1–3
- USB port 1–5
- USB port pin assignments 6–4

V

- vent location 1–4
- VGA monitor port 1–5
- video problems 2–3
- volume control
 - mute button 1–3
 - scroll zone 1–3

W

- warranty period 4–2
- wireless keyboard part number 3–2
- wireless mouse part number 3–2