

保固及支援手冊

**Limited Warranty and  
Support Guide**



# 保固及支援手冊

- 保固聲明
- 使用者授權合約
- 合格聲明
- 作業規格
- 法規及安全資訊
- 支援資訊

在洽詢「HP 顧客貼心服務」之前，請務必備妥下列資訊。

請花些時間填寫您電腦的產品資訊，以供日後參考。

您可以在電腦外部的貼紙上，找到清單上的前四個項目（型號、產品編號、序號和軟體組建編號）。

型號： \_\_\_\_\_

系統（產品）編號： \_\_\_\_\_

序號： \_\_\_\_\_

軟體組建編號： \_\_\_\_\_

作業系統： \_\_\_\_\_

購買日期： \_\_\_\_\_

## 硬體有限保固

HP 產品	持續時間
硬體	一 (1) 年有限保固*
電話協助 (讓您操作順暢)	三十 (30) 天

\*某些國家或地區的保固期限可能較長。請洽詢此產品的經銷商或 HP 網站：

<http://www.hp.com>

### 一般條款

本「HP 硬體有限保固」係由 Hewlett-Packard (製造商) 授與您 (顧客) 之明示有限保固權利。如需更多有關您的有限保固應得權益的說明, 請參閱 HP 的網站。此外, 在當地適用法律或與 HP 簽訂的特殊合約下, 您可能也擁有其他法定權利。

HP 不明示或默示其他保固或條件, 不論其為口頭或書面形式; 且 HP 明示否認非本「有限保固」內陳述的所有擔保和條件。當美國司法權以外的當地法律許可範圍下, HP 否認所有默示保固或條件, 包括購買及特定目的之適用性的任何默示保固。對於在美國境內發生的所有交易, 包括任何適售性默示保證或條件、品質滿意度或特定目的之適用性, 皆限於上述明示保固的期限。某些州或國家/地區不允許限制默示保固可持續的時間、或例外條款、或對消費者產品意外或衍生的損壞之限制。在這些州或國家/地區, 本「有限保固」的某些例外條款或限制可能不適用於您。

對於在澳洲和紐西蘭發生的消費者交易, 本聲明中包含之有限保固條款, 除法律允許之範圍外, 不得排除、禁止或修改適用於本產品交易的強制法定權利, 且是強制法定權利外的適用條件。

本聲明中包含之有限保固條款, 除法律允許之範圍外, 不得排除、禁止或修改適用於本產品交易的強制法定權利, 且是強制法定權利外的適用條件。

本「有限保固」適用於所有國家/地區, 而且可能會在 HP 或其授權服務供應商遵照本「有限保固」陳述的條款和條件提供相同產品型號的保固服務之任何國家/地區實行。

根據 HP「全球有限保固」(Global Limited Warranty) 方案，顧客可能會在一個國家/地區購買產品，然後將產品帶到 HP 或 HP 授權的服務供應商有提供相同產品型號之服務的國家/地區，而保固並不會因此作廢。保固條款、是否有提供服務和服務回應時間可能會依各國家/地區而有所不同。標準保固服務的回應時間會因當地的零件提供狀況而有所變動。詳情請洽您的 HP 授權服務供應商。

HP 不負責承擔在轉移產品時可能要支付的進出口關稅或特定稅款。產品的轉移可能會受到在美國或其他政府發佈的出口管制約束。

本「有限保固」僅適用於有提供本「有限保固」的 Hewlett-Packard 公司、其全球附屬公司、分公司、授權經銷商或國家/地區銷售商（在本「有限保固」中統稱為「HP」）所銷售或出租的 HP 廠牌與 Compaq 廠牌的硬體產品（在本「有限保固」中統稱為「HP 硬體產品」。「HP 硬體產品」一詞的定義僅限於硬體組件與所需的韌體。「HP 硬體產品」一詞「不」包括任何軟體應用程式或程式，亦不包括非 HP 產品或非 HP 廠牌的週邊設備。「HP 硬體產品」以外的所有非 HP 產品或非 HP 廠牌的週邊設備 — 例如：外接式儲存子系統、顯示器、印表機及其他週邊設備 — 係依「現況」提供，HP 概不做任何擔保。不過，非 HP 的製造商與供應商或發行商可能會直接為您提供其專屬的保固。

HP 保證，您向 HP 購買或租借的「HP 硬體產品」在「有限保固期」內如經正常的使用，並不會有材料或技術上的瑕疵。自您向 HP 購買或租借之日起，或者自 HP 完成安裝之日起，「有限保固期」即開始生效。標有產品購買或租借日期的銷售或送貨收據可做為購買或租借日期的證明。您可能需要提供購買或租借證明才能取得保固服務。如果您的「HP 硬體產品」在「有限保固期」內需要修理，您將可依據本文件的條款和條件享有硬體保固服務。

除非有另外聲明，且在當地法律許可的範圍下，新的「HP 硬體產品」可能會使用新材料，或者結合新材料與在效能和穩定性上等同全新的舊材料來製造。HP 可能會使用以下產品或零件來維修或更換「HP 硬體產品」：(a) 新產品，或在效能和穩定性上等同全新的舊產品或舊零件，或者 (b) 等同已停產之原廠產品的產品。更換的零件享有九十(90)天內在材料或製造上沒有瑕疵之保固，或者要更換或安裝的「HP 硬體產品」之「有限保固期」的剩餘期間（以較長的期間為準）。

HP 有權自行決定是否在「有限保固期」內維修或替換在材料或技術上產生瑕疵的組件或硬體產品。在「有限保固」範圍內拆卸的所有組件零件或硬體產品皆歸 HP 所有。雖然不容易發生，但如果您的「HP 硬體產品」重複發生故障，HP 可能會選擇提供您以下解決方案（由 HP 獨自決定）：(a) 由 HP 挑選的更換零件 – 完全相同或在效能上等同的「HP 硬體產品」，或者 (b) 根據您的購買價格或租借金額進行退費（不包括利息），而不提供更換品。這是對於您收到有瑕疵產品的唯一賠償。

### 例外條款

HP 不保證本產品的操作不會出現作業中斷現象或完全沒有錯誤。對於因未遵循「HP 硬體產品」的特定指示而產生的損壞，HP 概不負責。

本「有限保固」不適用於消耗組件或耗材、或任何無序號的產品，或因以下情況而有毀損或瑕疵的產品 (a) 由於意外、使用不當、濫用、污損、不當或不足的維護或校準、或其他外在因素；(b) 在本產品隨附的使用手冊內記載之使用範圍以外操作；(c) 透過非 HP 提供的軟體、介面、零件或供應品；(d) 不當的場地準備或維護；(e) 中毒；(f) 搬運時的遺失或損壞；(g) 經由非以下人員的修改或維修：(i) HP、(ii) HP 授權的服務供應商；(iii) 自行安裝一般用戶可更換的 HP 或 HP 認可的零件（如果在要進行維修的國家或地區可取得您產品的零件）。

您應該定期備份儲存在硬碟或其他儲存裝置中的資料，以防可能發生的故障、變更或資料遺失。在退還任何要維修的零件之前，請務必先備份資料並移除任何機密、獨有或個人資料。**HP** 不負責對任何程式、資料或抽取式儲存媒體造成的損害或損失。除了 **HP** 在製造產品時所安裝的軟體之外，**HP** 概不負責任何程式或資料的還原或重新安裝。接受維修的零件可能會刪除硬碟上的資料，而程式則會還原到原始狀態。

## 唯一賠償

在當地法律許可的範圍下，這些條款和條件為您與 HP 之間就您所購買或租借之「HP 硬體產品」所構成的完整且唯一的保固合約。這些條款與條件可取代任何先前的合約或陳述 — 包括 HP 銷售文獻中所提的陳述，或由 HP 或 HP 代理商或員工所提出的建議 — 可能與您購買或租借的「HP 硬體產品」有所關聯。除非變更是由 HP 授權代表以書面的形式制定與簽署，否則擅自變更本有限保固內的條件一概無效。

## 法律責任限制

如果您的「HP 硬體產品」無法如上述保證般運作，根據本「有限保固」，HP 的最大法律責任已明示限定為少於您購買本產品的金額，或者少於任何硬體組件在正常使用時發生故障所支付的維修或更換的費用。

除了上述列出的條款以外，對任何因產品造成或因產品故障導致無法作業所造成之損失，包括任何利潤或財產損失、或特殊、意外或衍生的損壞，HP 概不負責。對於任何由第三方提出的索賠，或由您為第三方提出的索賠，HP 概不負責。

本法律責任限制適用於是否有找到損壞，或者是否有根據本「有限保固」提出的索賠，或者作為侵權索賠（包括疏忽和嚴格的產品責任）、合約索賠或任何其他類型的索賠。任何人皆不得放棄或修改本法律責任限制。即使您已通知 HP 或 HP 授權代表任何此類損壞的可能性，本法律責任限制仍然有效。不過，本法律責任限制將不適用於對人身傷害的索賠。

本「有限保固」授與您特定的法定權利。您可能還有其他權利，可能會依各州或各個國家/地區而有所不同。建議您查詢適用的州或國家/地區之法律，以完整界定您的權利。

## 有限保固期

「HP 硬體產品」的「有限保固期」是自購買日起即生效的特定固定期限。銷售收據上的日期即為購買日，除非 HP 或您的經銷商另外以書面通知您。



## 保固服務類型

為了讓 HP 在「有限保固期」內能夠提供最佳的支援與服務，HP 可能會引導您檢查配置、載入最新韌體、安裝軟體增補程式、執行 HP 診斷測試或使用 HP 遠端支援解決方案（若可使用）。

HP 強烈鼓勵您使用或利用 HP 提供的可用支援技術。如果您選擇不要使用可用的遠端支援功能，您也許會因為增加所需的支援資源而必須支付額外的費用。以下列出您購買的「HP 硬體產品」可能適用的保固支援服務類型。

### 到府保固服務

「HP 有限保固」服務可能包含到府維修支援以修復您的硬體。HP 提供標準上班時間內的到府服務。一般的標準上班時間為 08:00 至 17:00（週一至週五），但可能會依當地營運制度而有所不同。如果您的所在地超出平常的服務區（通常為 50 公里），回應的時間可能就會久一些，或者可能需要向您收取額外的費用。若要尋找離您最近的 HP 授權服務供應商，請參閱 HP 網站上的資訊，網址為：

<http://www.hp.com/hk/support>

或

<http://www.hp.com.tw/support>

HP 可能會自行決定是否需要採到府維修保固服務。例如，在許多情況下，瑕疵都可以透過「客戶自行維修」(Customer Self Repair, CSR) 方案修復 — 您需要依照 HP 提供的指示和說明文件自行更換。您也需要配合 HP 透過電話嘗試解決問題。解決問題的方法可能包含執行例行診斷程序、安裝軟體更新或增補程式、移除協力廠商配件和/或取代配件。要得到到府支援，您必須：(a) HP 到府提供保固服務時，一名代表人須全程在場；(b) 通知 HP 產品使用的環境是否可能會危及 HP 工作人員或承包人員的健康或安全；(c) 在合理的安全要求下，提供經由 HP 判定為必要之所有設施、資訊和系統的充足、自由與安全的取得和使用，以適時提供即時支援；(d) 確認所有的製造商標籤（例如序號）都有貼好、容易找到且容易辨識；(e) 維持與產品規格和支援的配置一致的環境。

如果您需要 HP 代表來處理所有組件更換，請支付額外的費用取得支援升級合約。

## 回廠保固服務

根據回廠維修條款，您需要將「HP 硬體產品」送到授權的保固維修服務站。您必須預付產品在府上與維修站間來回運送時所需的運費、稅金或關稅。此外，您也必須負責投保任何運送或寄回授權維修站的產品，並承擔在運送過程中可能遺失的風險。

## 送修保固服務

「HP 有限保固」可能有包含送修保固服務。根據送修服務條款，您將需要把「HP 硬體產品」運送到授權的保固維修服務站。您必須預付產品在府上與維修站間來回運送時所需的運費、稅金或關稅。此外，您需負責您所運送的任何產品之保險，並承擔運送途中遺失的風險。HP 會將已維修的產品送回府上，並支付所有送回產品給您的物流和保險相關費用。

## 收回與送回保固服務

「HP 有限保固」可能包含收回與送回保固服務。根據收回與送回服務的條款，HP 將會到您的所在地收回有瑕疵的零件、修好之後再將它送回您的所在地。在此服務流程中，HP 將會支付所有維修、物流和保險費用。

## 客戶自行維修保固服務

在適用的國家/地區，「HP 有限保固」可能有包含客戶自行維修保固服務。如果有此服務，HP 將自行決定客戶自行維修是否為適當的保固服務方法。如果適當，HP 將會直接寄送認可的更換零件給您，以履行「HP 硬體產品」保固服務。這會節省您許多修理時間。在您連絡 HP 且故障診斷指出可以使用其中一個零件來修復此問題後，就會直接將更換的零件寄給您。收到零件後，請依據提供的指示和說明文件更換有瑕疵的零件。如果還需要額外的協助，請連絡「HP 技術支援中心」。技術人員將會透過電話提供您協助。如果必須將更換的零件送回 HP，您就必須在規定的期限（通常是十五 (15) 天）內將有瑕疵的零件寄回 HP。有瑕疵的零件必須和相關說明文件包在提供的運送材料中一同寄回。如果沒有寄回有瑕疵的產品，HP 可能會向您收取更換零件的費用。對於客戶自行維修方案，HP 將會支付所有運輸和零件寄回的費用，並決定要使用的快遞業者/運輸業者。如果您適用客戶自行維修方案，請參閱您特定的「HP 硬體產品」通知。您也可以到 HP 網站取得此保固服務的資訊，網址為：

<http://www.hp.com/hk/support>

或

<http://www.hp.com.tw/support>

## 服務升級

HP 針對您可在當地購買的產品包含一系列的額外支援與服務。不過，某些支援和相關產品可能無法在所有國家/地區取得。如需得知是否有提供服務升級以及服務升級費用的相關資訊，請參閱 HP 網站，網址為：

<http://www.hp.com/hk/support>

或

<http://www.hp.com.tw/support>

## 選購裝置與軟體有限保固

大部分 HP 廠牌選購裝置（「HP 選購裝置」）的「有限保固」條款和條件列示於「HP 選購裝置」適用的「有限保固」中，並包含在「HP 選購裝置」的產品包裝中。如果您的「HP 選購裝置」是安裝在「HP 硬體產品」，HP 可能會提供一段時間的保固服務，時間期限為隨附「HP 選購裝置」提供的保固文件（「HP 選購裝置有限保固期」）中所指定的時間，或者安裝「HP 選購裝置」的「HP 硬體產品」剩餘的保固時間，以時間較長者為主，但不得超過自您購買「HP 選購裝置」當天日期算起三 (3) 年。「HP 選購裝置有限保固期」從您向 HP 或 HP 授權經銷商購買日起生效。標有日期的銷售或送貨收據（顯示「HP 選購裝置」購買日期）即為保固開始日期。詳情請參閱「HP 選購裝置有限保固」。非 HP 的選購裝置係依「現況」提供。不過，非 HP 的製造商與供應商可能會直接為您提供保固。

除非適用的軟體使用者授權合約或程式授權合約中有提供，或是當地法律有另外提供，軟體產品 — 包括任何由 HP 預先安裝的任何軟體產品、免費軟體（如下述定義）或作業系統 — 係依「現況」和「連同本身具有之一切瑕疵」提供，而且 HP 特此否認所有其他保固和條件，無論是明示、默示或法定，包括但不限於標題和無侵權的保固、對於購買、特定目的之適用性，及完全沒有病毒的任何默示保固、責任或條件。某些國家 / 管轄地區不允許在暗示的保證期間內暗示性保證或限制除外責任，所以上述的拒絕聲明可能就不適用於您的地區。在適用法律許可的最大範圍下，HP 或其供應商對任何特殊、意外、間接或衍生的損壞等類（包括但不限於利益損失、機密或其他資料、營業中斷、人身傷害、由於或以任何關於使用或無法使用「軟體產品」的方式而喪失隱私）概不負責，即便您已通知 HP 或任何供應商此類損壞的可能性，且即便賠償失去其必需之目的亦是如此。某些國家 / 管轄地區不允許意外或損害賠償的除外責任或限制，所以上述的拒絕聲明可能就不適用於您的地區。

HP 對於以 HP 廠牌名稱由 HP 所分發的軟體，其唯一的保固責任列於與軟體一同提供之適用的使用者授權合約或程式授權合約。自購買日算起三十 (30) 天內，如果 HP 分發軟體的卸除式媒體經證明發現在材料或技術上有瑕疵，您可以將該卸除式媒體寄回 HP 進行更換。這是您唯一能夠獲得的賠償。若是空白磁帶卸除式媒體，請參閱以下網站：

<http://h20000.www2.hp.com/bizsupport/TechSupport/Document.jsp?objectID=lpg50101>

您有責任連絡非 HP 製造商或供應商以取得其保固支援。

## 軟體技術支援

HP 對您的「HP 軟體」、HP 預先安裝的協力廠商軟體以及您向 HP 購買的協力廠商軟體提供「軟體技術支援」，並可透過許多連絡方式（包括電子媒體和電話）取得（自購買日期起的三十 (30) 天內）。請參閱〈連絡 HP〉以得知線上資源和電話支援的資訊。對此的任何例外將會記載於「使用者授權合約」(EULA) 中。

「軟體技術支援」包括對以下事項的協助：

- 解答您的安裝問題（提供方法、開始步驟和先決條件）。
- 設定和配置軟體（方法和開始步驟）。不包括系統最佳化、自訂及網路配置。
- 解讀系統錯誤訊息。
- 區分問題是屬於系統問題或軟體使用問題。
- 取得支援服務套件 (support pack) 資訊或更新。

軟體技術支援「不」包括對以下事項的協助：

- 產生或診斷使用者產生的程式或原始碼。
- 安裝非 HP 的產品。

## 連絡 HP

如果您的產品在「有限保固期」內發生故障，而且產品說明文件中的建議也無法解決問題，您可以透過以下途徑取得支援：

- 透過「全球資訊網」找出離您最近的 HP 支援服務據點：

**<http://www.hp.com/hk/support>**

或

**<http://www.hp.com.tw/support>**

- 連絡 HP 授權經銷商或「授權服務供應商」。在致電 HP 之前，請務必備妥以下資訊：
  - 產品序號、型號名稱以及型號
  - 出現的錯誤訊息
  - 附加選購裝置
  - 作業系統
  - 協力廠商硬體或軟體
  - 問題細節

### 如何洽詢保固及支援權益？

請洽詢 **<http://www.hp.com/hk/support>** 或 **<http://www.hp.com.tw/support>** 獲得有關保固、維修與支援以及產品資訊更新的資訊。

# 最終使用者授權合約

請仔細閱讀本文件，再開始使用本設備：本最終使用者授權使用合約（「EULA」）是 (a) 您（個人或公司團體）和 (b) Hewlett-Packard 公司（「HP」）之間的合法合約，讓您有權使用由 HP 安裝或提供給 HP 產品（「HP 產品」）的任何軟體產品，而不用另外與 HP 或提供廠商另訂合約。其他軟體的 EULA 可能包含在其線上說明文件中。「軟體產品」一詞是指電腦軟體，也包含相關媒體、平面資料和「線上」或電子使用說明文件。本 EULA 的修正和追加條款可能會在購買 HP 產品時提供。

只有在您同意本 EULA 所有條款和條件的情況下，才能享有本軟體產品的權利。只要按下「我同意」按鈕，表示您同意接受本 EULA 所述的所有條款。如果您不同意，請按下代表不同意本 EULA 條款的按鈕，且不要安裝、複製、下載或以其他方式使用本軟體產品。您可以在購買後十四天內，將未使用的軟體產品及 HP 硬體退還到原購買地點，並取回當初支付的費用。

1. 授權範圍。HP 依照 EULA 所述的所有條款授予您下列權利：

a. 使用。您可以在一台電腦（「您的電腦」）上使用本軟體產品。如果本軟體產品透過國際網路提供，且原始授權給一或多部電腦使用，則您僅能在這些電腦上安裝並使用本軟體產品。您不能分割本產品並在超過一台的電腦上使用。您沒有散佈本軟體產品的權利。為了使用本軟體產品，您可以下載到電腦的暫存記憶體 (RAM) 裡。

b. 儲存。您可以將本軟體產品複製到本機記憶體或 HP 產品的儲存裝置。

c. 複製。您可以對軟體產品建檔或做檔案備分，所有副本都有原始軟體產品的版權聲明，只能在備份目的上。

d. 保留的權利。HP 與其供應商保留所有本 EULA 未明文授予的所有權利。

e. 免費軟體。除了本 EULA 的條款與條約，組成本軟體產品所有或部分由非 HP 專屬軟體，或在協力廠商公開授權條件下所提供的軟體（「免費軟體」），其授權使用必須符合此種免費軟體隨附之軟體授權合約規定條款，無論其合約型式是否為個別授權、拆封授權或是在下載時所接受的電子授權條款。您在使用免費軟體時將完全受到本授權書所有條款的約束。

f. 修復解決方案。所有 HP 產品所提供的軟體修復解決方案，無論是硬碟架構型式、外部媒體修復解決方案（例如，軟碟、CD 或 DVD）或是任何其他相同之解決方案，僅供 HP 產品在原始購買時所附修復解決方案規定用於復原 HP 產品硬碟。修復解決方案所包含之任何 Microsoft 作業系統軟體的使用，均受 Microsoft 授權合約的約束。

2. 升級。要使用升級版軟體產品，您必須先註冊 HP 提供的原始軟體產品，才能升級。升級後，您可能不會再用到升級前原始的軟體產品。

3. 補充軟體。本 EULA 允許對 HP 提供的原始軟體產品進行更新或取得補充軟體，除非 HP 在更新或補充軟體中有其他條款。若是條款之間發生衝突，則以其他條款為主。

4. 轉讓。

a. 協力廠商。本軟體產品最初的使用者能有一次轉讓軟體產品給其他使用者的機會。轉讓必須包括所有組成部分、媒體、平面資料、本 EULA 及鑑定證明（如果適用的話）。轉讓不能是像託賣這類間接的轉讓。轉讓之前，接受轉讓產品的使用者必須同意 EULA 的所有條款。轉讓軟體產品之後，您的授權使用會自動終止。

b. 限制。您不能租賃或借出本軟體產品，或者為了商務分攤時間或機關用途來使用本軟體產品。除非本 EULA 有明確指出，否則您不能轉授權、讓渡或轉移權利或軟體產品給他人。

5. 所有權。軟體產品與使用說明的智慧財產權是 HP 或其供應商所有，受法律保護，包括美國著作權法、商業機密法和商標法，及其他適用著作權法和國際協議條款。您不應移除軟體產品上的產品辨別資料、版權聲明或所有權限制。

6. 反向工程限制。您不可以對本軟體產品進行反向工程、反向編譯或反向組譯，但若依據適用法令或本 EULA 明文提供則不在此限。

7. 條款。本 EULA 未終止或被拒絕之前，均視為有效。本 EULA 根據合約中所提出的條件，或您不遵守合約的條款或條約時，也會終止。

8. 同意資料的使用。您同意 HP 和其相關公司能收集並使用您提供有關本軟體產品支援服務的技術資訊。HP 同意不將本資訊用在任何會指認出個人身分的事物上，除非有必要提供這類服務。

9. 拒絕保證。在法律允許最大範圍內，HP 與其供應商皆以「現況」及買方承擔一切責任提供本軟體產品，並且不負任何其他保固和條款責任，不論明示、暗示或法律規定，包括但不限於所有

權與無仿冒之保證、任何有關適售性與符合特定使用目的之默示保固，或是不含病毒等所有與本軟體產品相關的默示保固。某些國家 / 管轄地區不允許在暗示的保證期間內暗示性保證或限制除外責任，所以上述的拒絕聲明可能就不適用於您的地區。

10. 責任限制。無論您的損失如何，根據本 EULA 的條款，HP 和其供應商的所有責任以及您因上述情況所得到唯一的補償，不得超過您實際購買本軟體產品的金額或美金 5 元。在法律允許最大範圍內，在任何情況下，即使 HP 或任何供應商已被告知有下列損壞發生的可能性，HP 或其供應商對於您的購買或使用任何產品所造成任何特殊、意外、間接或連帶所產生的損害（包括但不限於）資產、信譽或其他資訊損失、商業中止、個人傷害，以及其他與本 EULA 相關的損失，概不負責。某些國家 / 管轄地區不允許意外或損害賠償的除外責任或限制，所以上述的拒絕聲明可能就不適用於您的地區。

11. 美國政府買方。符合 FAR 12.211 和 12.212，在 HP 標準的商業授權之下，將商業電腦軟體、電腦軟體說明文件，以及商業項目的技術資料授權給美國政府。

12. 遵守輸出品管制法。您應該遵守美國和其他國家 / 地區（「輸出品管制法」）的法律和規定，確保本軟體產品不會 (1) 在違反輸出品管制法的情況下，直接或間接出口；或 (2) 使

用在輸出品管制法禁止的用途上，包括（但不限於）擴展核武、化學武器或生化武器。

13. 訂約能力與權力。您表示已在您居住的所在地達到法定年齡，以及（如果適用的話）您的雇主正式授權您簽訂合約。

14. 適用法律。本 EULA 依據美國加州法律實施。

15. 完整合約。本 EULA（包括任何隨附於 HP 產品的增補條款）是您與 HP 之間對此軟體產品的完整合約，其效力超越或等同所有與本軟體產品有關的口語或書面通訊、提案與展示，或本授權合約所涵蓋的任何其他事項。針對任何 HP 用於支援服務的條款或計劃與本 EULA 條款發生衝突情形，本 EULA 條款具有控制權力。

© 2004 Hewlett-Packard Development Company, L.P. The information contained herein is subject to change without notice. All other product names mentioned herein may be trademarks of their respective companies. The only warranties for HP products and services are set forth in the express warranty statements accompanying such products and services . Nothing herein should be construed as constituting an additional warranty. HP shall not be liable for technical or editorial errors or omissions contained herein.

Rev. 06/04



## 合格聲明

依據 ISO/IEC 17050-1 和 EN 17050-1

供應商名稱： Hewlett-Packard Company  
供應商地址： Hewlett-Packard Company  
10955 Tantau Ave  
Cupertino, CA 95014

### 聲明下列產品

產品： 個人電腦  
型號： 800、900  
a000、a1000、a5000、a6000  
CQ2000、CQ5000  
d1000、d4000、dx2000、d5000  
e9000  
g2000、g3000  
m000、m1000、m5000、m7000、m8000、m9000  
p6000  
s0000、s3000、s5000、s7000  
SR1000、SR2000、SR5000、SA4000、SV2000、  
SV7000、SG2000、SG3000  
t000、t3000  
u6000  
v2000、v7000  
w1000、w5000  
x5000、z500、z6000 系列

產品選項：

數據機卡： RD01-D850、CX-9Z-NR0134、A40、C40  
藍芽： BM-GP-BR-51  
電視  
調諧器卡： 71xxx、74xxx、78xxx、26xxx、25xxx、  
JayHawk、Fennec、Twolf  
鍵盤： 51xx、5335U、KB-06xx、KB-09xx、  
KBPH-0806、KM713A、KG-0851、  
KU-0841、SK806A、SK29xx、I101-P01、  
PR11-01、PR1101U、RK713A、9131URF、  
5189URF、KBRF1921  
滑鼠： KM713A、RM713A、M389、M889、  
MG-0856、MOAFUO、MOBJKC、  
MOBJKO、MOBLUL、MODGUO、  
M-SBQ133、M-SBP133、M-SBF96、  
M-U0009-HP1、MSPO-0701、M60PB、  
N17RBP、N17ROPKYE、9131URF、  
5189URF、MORFB1UO、UAE96、  
MORFDIUO、N910U



符合下列產品規格：

<b>安全法規：</b>	IEC 60950-1: 2001 / EN60950-1: 2001 EN 60825-1: 1994 + A1: 2002 + A2: 2001, Class 1 (Laser/LED)
<b>EMC：</b>	CISPR 22: 1997 / EN 55022: 1998 +A1: 2000 +A2: 2003, Class B / EN 55022: 2006, Class B CISPR 24: 1997 / EN 55024: +1998 +A1: 2001 +A2: 2003 EN 55020: 1995/ EN 55020: 2002 +A1: 2002 + A2: 2005 EN 55013: 2001 +A1: 2003 EN 61000-3-2: 2006, Class D EN 61000-3-3: 1995 + A1: 2001+ A2: 2005 FCC Title 47 CFR, Part 15 Class B / ICES-003 AS/NZS CISPR 22: 2004/ AS/NZS CISPR 22: 2006
<b>Telecom：</b>	TBR 21: 1998 1998 EN 300328: V.1.7.1，無線電設備專用的技術要求。

**補充資訊：**

本產品符合 Low Voltage Directive 2006/95/EC、EMC Directive 2004/108/EEC 及 R&TTE Directive 99/5/EC 的要求，因此附有「CE 標誌」。

本裝置符合 FCC 規定的 Part 15。使用本裝置受到下列兩個條件的約束：(1) 本裝置不會導致有害的干擾；(2) 本裝置必須接受任何接收到的干擾，包括可能導致意外的操作干擾。

Cupertino, CA USA 2008 年 12 月 3 日

**如僅需法規遵循資訊，請連絡：**

澳洲連絡人：Product Regulations Manager, Hewlett-Packard Australia Pty Ltd.,  
31-41 Joseph Street, Blackburn, Victoria 3130

歐洲連絡人：Hewlett-Packard GmbH, HQ-TRE, Herrenberger Straße 140,  
71034 Böblingen, Germany

北美連絡人：Hardware Quality Eng. Manager, Hewlett-Packard, CPC,  
10955 Tantau Ave., Cupertino, CA 95014

# 作業規格

電氣額定值：	AC 輸入	100–127V $\sim$ ，3A 或 4A 或 6A* 200–240V $\sim$ ，2A 或 3A*
	50/60 Hz	
作業溫度：	攝氏 5 度到 35 度	
儲存溫度：	攝氏 -30 度到 65 度	
作業溼度：	攝氏 26 度下 15% 到 80%	
作業高度：	0 到 2000 公尺	
儲存高度：	0 到 4572 公尺	

\* 請見電腦背面的電腦額定值標籤，以得知正確的電器額定值。

## 法規及安全資訊



**警告：**此類文字代表如果無法遵照指示操作，可能會造成設備損壞、資料遺失、人身傷害或喪失生命。

- 內附已連接電源的零件與可活動零件。拆卸外殼前，請先中斷設備電源。
- 重新接上設備電源前，請先裝回並固定好外殼。
- 電腦很重，搬動電腦時，請使用符合人體工學的搬運方法。
- 在安裝及將電腦接上電源系統之前，請先閱讀本手冊稍後的〈其他安全資訊〉一節。

電池隨產品一起出貨。當電池的電力用完後，請不要將其丟棄，請將電池以小型化學廢棄物回收。

### 化學物質

HP 致力於在必要時提供客戶有關產品內的化學物質資訊，以符合法規要求，例如：REACH（歐洲議會與歐洲理事會法規 (EC) No 1907/2006）。您可以在以下網址獲得此產品的化學物質報告書：

<http://www.hp.com/go/reach>

## 關於 Energy Star 的重要資訊

標有 ENERGY STAR® 標誌的 HP 電腦符合美國環保署 (EPA) 的 ENERGY STAR 應用於電腦的規格。EPA ENERGY STAR 的標誌並非默示 EPA 對此產品的背書。Hewlett-Packard 公司為 ENERGY STAR 的夥伴，並確認包裝上標有 ENERGY STAR 標誌的產品，符合了應用於 ENERGY STAR 的節約能源方針。您可在符合 ENERGY STAR 方針的電腦上看到下列標誌：



EPA 所發起的 ENERGY STAR Computers Program 目的為推廣在家中、辦公室以及工廠裡使用比較節省能源的設備，以節約能源與減少空氣污染。這些產品節約能源的其中一個方法就是透過 Microsoft Windows® 「電源管理」功能，使產品在閒置時降低電源消耗。

「電源管理」功能可以使電腦在處於靜置狀態一段時間後，進入低電力或「睡眠」模式。使用符合 ENERGY STAR 標準的外接顯示器時，此功能仍會支援顯示器的電源管理功能。若要使用此節能功能，請執行以下操作：

- 將「電源管理」功能預設為在電腦進入閒置狀態 20 分鐘後關閉電腦。
- 將「電源管理」功能預設為在電腦進入閒置狀態 15 分鐘後關閉顯示器。

透過與任何一種電腦輸入裝置（例如：滑鼠、鍵盤等）進行使用者互動，就可將電腦和顯示器從「睡眠」模式中喚醒。如果啟用了 Wake On LAN (WOL)，您還可以透過網路訊號喚醒電腦。

有關「電源管理」功能節省能源和成本的更多訊息，請至 EPA 的 ENERGY STAR 電源管理網站：  
**[www.energystar.gov/powermanagement](http://www.energystar.gov/powermanagement)**

有關 ENERGY STAR 計畫以及環保效益的更多資訊，可在 EPA ENERGY STAR 網站取得，網址為：  
**[www.energystar.gov](http://www.energystar.gov)**



**警告事項：**在不符合 **ENERGY STAR** 標準的顯示器上使用「節能顯示器」功能可能會出現節能逾時，造成視訊扭曲。

## 音訊音量聲明

長時間以高音量聆聽音樂可能會對聽力造成損害。若要降低聽力損害的風險，您必須將音量降低到安全、舒適的程度，並減少以高音量聆聽的時間。

- 為了您的安全起見，在使用耳機麥克風或耳機之前，請務必重新設定音量。即使音量控制設定相同，某些耳機的音量仍會大於其他耳機。
- 變更預設音訊或等化器設定可能會導致較高的音量，進行設定時請多加留意。
- 如果 HP 產品編號包含電腦以及耳機麥克風或耳機，則該組合符合 EN 50332-1 的規定。
- 一般而言，音訊音源輸出介面並不適用於耳機麥克風或耳機。



**警告：**在使用本裝置時，請遵循下列安全防範措施以降低火災、觸電及人身傷害的風險：

- 請勿在近水之處使用本產品，如浴缸、洗手台、廚房洗碗槽、洗衣盆、潮濕的地下室或靠近游泳池的地方。
- 避免在雷電暴風雨中使用本產品，以降低遭受閃電攻擊的危險性。
- 請勿使用本產品在瓦斯漏氣附近通報瓦斯漏氣。
- 在打開此設備之內件或接觸未絕緣的數據機纜線、插孔或內部組件時，請務必先拔除數據機纜線。
- 若此產品未隨附提供電話線，請您僅使用 **No. 26 AWG** 或更大規格的電話線，以降低發生火災的風險。
- 請勿將數據機纜線或電話線插到網路介面卡 (**NIC**) 的插孔上。

請保存這些指示

---

## 其他安全資訊

本產品尚未進行與「IT」電源系統（按照 IEC 60950 標準，不直接接地的交流電配電系統）連接的評估。

### AC 電源安全警告



**警告：**請將電腦安裝在 **AC** 插座附近。**AC** 電源線是電腦主要的 **AC** 電源中斷裝置，故您必須可隨時操控 **AC** 電源線。基於安全考量，電腦隨附的電源線附有一個接地插頭。請務必將電源線插在牆上的接地插座，以避免觸電的危險。

電腦附有適用於 **115** 或 **230 V** 電源系統的電壓切換開關。此電壓切換開關已預先設定為正確的電壓值（適用於其最初銷售的國家/地區）。將電壓切換開關變更到錯誤的位置將會導致電腦受損，並使所有的明示保固條款無效。

為減少來自電話網路電擊的可能性，將電腦與電話線連接之前先將電腦插頭插入 **AC** 電源插座。此外，從 **AC** 電源插座拔出電腦插頭時應先中斷電話線連接。

安裝或移除電腦外殼之前，務必先中斷電話系統與數據機的連接。

請勿在外殼打開的時候操作電腦。

為了安全起見，進行任何維修程序之前，切記要切斷電腦與電源的連接，並切斷其與任何通信系統（如電話線路）、網路或數據機的連接。否則，將可能導致人身傷害或設備毀損。本產品的電源供應器和數據機內部都有危險電壓。

### 鋰電池警告事項



**警告：**本電腦使用 **CR2032** 型的鋰電池。如果更換錯誤的電池，可能會有爆炸的危險。更換電池時，僅使用生產廠商建議的相同或同等型號的電池。並按照生產廠商的指示處理用過的電池。

### 雷射安全聲明

#### Class 1 LED 產品

CD 和 DVD 光碟機包含一組雷射系統，根據 Radiation Control for Health and Safety Act of 1968，在美國 Department of Health and Human Services (DHHS) Radiation Performance 中已分類為「Class 1 雷射產品」。

如果本組件需要維修，請與授權的維修處連絡。



**警告：**除了在《升級與維護手冊》中指明的以外，其他的控制、調整或執行步驟可能導致嚴重的輻射危害。為了避免暴露在雷射光束下，請勿打開 **CD** 或 **DVD** 光碟機的外殼。

## 雷射產品標籤

下列的標籤或同等標籤位於雷射產品的表面：



本標籤表示此產品被歸類為「CLASS 1 雷射產品」。此標籤會黏貼在安裝至您產品中的雷射裝置上。

## 電視天線接頭保護

### 電視外部天線接地

如果您將外部天線或有線系統連接到本產品，應確保天線或有線系統接地以避免電壓突波和累積的靜電放電。Article 810 of the National Electrical Code, ANSI/NFPA 70 已提供下列相關資訊：天線杆和支撐結構的正確接地、饋入線到連接天線放電組件的接地、接地導體的大小、天線放電組件的位置、接地電極的連接以及接地電極的要求。

### 雷電保護

在出現雷電時，或者產品閒置一段較長時間時，為了加強保護，請從牆上插座拔下產品插頭並中斷天線或有線系統的連接。這將在雷電和電源線路發生突波時保護本產品。

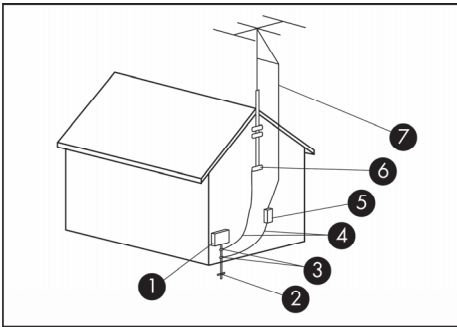

天線接地

天線接地

參考	接地組件
①	電氣服務設備
②	配電器接地電極系統 (NEC Art 250, Part H)
③	接地線箍
④	接地導體 (NEC Section 810-21)
⑤	天線放電組件 (NEC Section 810-20)
⑥	接地線箍
⑦	天線導入線

### 電源線路

嚴禁將外部天線系統置於高架電源線或其他電燈或電路附近，或者置於電源線或電路上方。



**警告：**安裝外部天線系統時，尤其要注意不要去接觸電源線或電路，否則會有生命危險。

# 支援資訊

別忘了註冊！

請造訪：<http://www.hp.com/hk/register>

## 如何取得協助

當您需要協助時，請依下列步驟處理：

- 1 查看安裝海報和產品手冊中關於設定及使用電腦的說明。
- 2 使用「說明及支援中心」取得硬體和軟體問題的說明。按一下 **[開始]**，然後再按 **[說明及支援]**。「說明及支援中心」提供有用的疑難排解資訊並包括下列：
  - 電子郵件支援。
  - 與合格的支援專員進行「HP 即時線上對談」。
  - 支援專線。
- 3 若您有關於硬體的問題，請在連絡「HP 顧客貼心服務」前，執行預先安裝在電腦的硬體診斷工具。按一下 **[開始]**、**[所有程式]**、**[PC 說明和工具]**，然後按一下 **[硬體診斷工具]**。
- 4 如需線上協助，請前往「HP 顧客貼心服務」網站，網址為：  
<http://www.hp.com/hk/support>  
或  
<http://www.hp.com.tw/support>  
以取得技術性資訊或軟體更新。
- 5 如果仍然無法解決問題，請與「HP 顧客貼心服務」連絡，電話號碼如下。  
香港特別行政區：**28024098**  
澳門特別行政區：**0800 366**  
服務時間：週一至週五：9:00 – 18:00，週六：9:00 – 13:00  
台灣：**0800 095 996**  
服務時間：週一至週六：8:30 – 21:00  
(專線服務時間如有變更，恕不另行通知)

## HP 支援網站

<http://www.hp.com/hk/support>

或

<http://www.hp.com.tw/support>

## 致尊貴的客戶

恭喜您決定購買桌上型電腦！在開發過程中，電腦必須通過全面的品質測試，以符合以品質及可靠度著稱的嚴格標準。

在出廠前，所有的電腦都會通過全面的品質測試，以確保電腦運作正常。此外，我們還在您的電腦上加貼安全封條，以表示電腦出廠後未受到任何的損害。

我們深知客戶最重視的權益是擴充和升級。擴充性及升級能力是我們的電腦讓人引以為傲、有別於其他產品之處。我們也了解您希望將電腦升級，以符合個人的特殊需求。

您應該在完成新電腦的安裝後，再進行任何硬體的升級。請參照系統隨附的安裝海報以協助您進行安裝。若您在安裝及啟動系統時遇到任何問題，請立刻打電話到《有限保固及支援手冊》中先前列出的「HP 顧客貼心服務」，HP 的客服代表會協助您解決所遭遇的問題。您必須在試圖升級您的系統前，完成此項動作。

撕開電腦背面安全封條的動作，代表您確認電腦在您試圖升級前的運作是正常的。安全封條撕開之後，您的電腦（在當地法律許可的範圍下）將會受到列於〈硬體有限保固〉一節的條款與條件之保障。

感謝您購買這台電腦。希望您能在探索這部電腦所有功能的過程中找到樂趣！

## 顧客支援

取得容易、輕鬆使用。曾獲獎項肯定的「HP 顧客貼心服務」是我們對您的具體承諾，並協助您充分利用您的電腦。無論是透過電腦上的工具、網路上的資訊、電話還是您當地的經銷商，您都可以得到滿意的結果。

## 有問題嗎？HP 會幫您解決

您新電腦已經準備就緒，將供您現在和未來的若干年使用。但它仍是一部複雜、功能強大的機器，有時也會發生故障。如果您的電腦發生故障，HP 會隨時提供協助。

## 快速入門

遵循安裝海報及《快速入門》指南中關於設定及使用電腦的說明。



## 了解您可以做的事

電腦中包含許多有用的資訊。首先看看在 Windows 桌面的【說明】（請按一下【開始】，然後按一下【說明及支援】即可找到）。此功能擁有更詳細的說明，並提供解決問題的建議。

在「說明及支援中心」之中，您可以從 HP 獲得與您電腦有關的最新消息。也請您務必查看 HP 不定期傳送至您桌面的更新消息。

接下來，不妨上網逛逛！HP 網站有更新的軟體、提示和技巧、一般問題解答以及其他資訊。請到本文件之前所列的〈支援網站〉搜尋您的電腦型號。

### 打電話到「HP 顧客貼心服務」

最後，如果這些步驟都沒有幫助，您可以打電話到當地的「HP 顧客貼心服務」，即可獲得專業的專人服務。自購買本電腦之日起三十 (30) 天內，您可免費獲得電話諮詢協助，使您順暢地操作電腦。超過三十 (30) 天後這項服務便須收費，但您仍可獲得其他令人滿意的服務。

### 如果需要：進行維修

如果您的電腦需要維修或更換零件，您有兩種選擇：

- 您可以輕鬆更換許多被視為可由客戶自行更換的電腦零件。這是最快的維修方式，因為通常我們在幾天內即可將零件直接送到您的家裏或公司。
- 如果需要維修，「HP 顧客貼心服務」將會安排維修電腦的相關事宜。

在保固期內這些服務都是免費的。

這項保固服務有幾點限制和例外（以及一些重要細節），將在〈硬體有限保固〉一節中說明。

## 了解硬碟空間

預先安裝 Microsoft Windows 作業系統的 Hewlett-Packard 和 Compaq 電腦，其硬碟可能比產品規格、說明文件或包裝箱上所陳述的規格還小。製造商所描述及宣稱的硬碟空間是以十進制 (base 10) 來計算的。Windows 與其他程式 (例如 FDISK) 是則採用二進位 (base 2) 計算系統。Microsoft Windows 與其他程式 (例如 FDISK) 是使用二進位 (base 2) 計算系統。

在十進位記數法中，1 個 Megabyte (MB) 等於 1,000,000 個位元組，而 1 個 Gigabyte (GB) 等於 1,000,000,000 個位元組。在二進位記數系統中，1 個 Megabyte 等於 1,048,576 個位元組，而 1 個 Gigabyte 等於 1,073,741,824 個位元組。因為記數系統不同，所以 Microsoft Windows 記錄的大小與製造商宣稱的不同。其實兩者所描述的硬碟儲存空間是相同的。

Microsoft Windows 在 [Windows 檔案總管] 工具與 [電腦] 視窗中報告的容量較小，因為它一次只顯示硬碟上一個分割區的資料。其中一個磁碟分割區會包含系統復原資訊。

### 系統記憶體設為 **4GB** 時的注意事項

如果您使用的是 32 位元作業系統的電腦，所有 3GB 以上的記憶體可能會因為系統資源需求的限制而無法使用。

HP 和 Compaq 系統並沒有上述的限制。超過 3GB 的記憶體將做為系統資源使用。

### 確認總記憶體

系統 BIOS 會顯示所有已安裝的 4GB 記憶體。

- 1 開啟電腦。
- 2 按下 F1 鍵。接著顯示 BIOS 功能表。確認總安裝記憶體。

手冊中所包含之資訊可隨時更改，恕不另行通知。

Copyright © 2008–2009 Hewlett-Packard Development Company, L.P.



# Limited Warranty and Support Guide

- Warranty Statement
- End-User License Agreement
- Declaration of Conformity
- Operating Specifications
- Regulatory and Safety Information
- Support Information

Before contacting the HP Customer Care Center, it's important to have the following information handy.

Please take a moment to write down your product information for future reference.

The first four items on the list (Model Number, Product Number, Serial Number, and Software Build Number) can be found on a sticker on the outside of your computer.

Model Number: \_\_\_\_\_

System (Product) Number: \_\_\_\_\_

Serial Number: \_\_\_\_\_

Software Build Number: \_\_\_\_\_

Operating System: \_\_\_\_\_

Purchase Date: \_\_\_\_\_

# Hardware Limited Warranty

## HP Product

Hardware

Phone assistance to get  
you up-and-running

## Duration

One (1) year limited warranty\*

Thirty (30) days

\*The warranty period may be longer in certain countries/regions. Please check with the seller of the product or consult the HP Web site at: <http://www.hp.com>

## General Terms

This HP Hardware Limited Warranty gives you, the customer, express limited warranty rights from Hewlett-Packard, the manufacturer. Please refer to HP's Web site for an extensive description of your limited warranty entitlements. In addition, you may also have other legal rights under applicable local law or special written agreement with HP.

HP MAKES NO OTHER EXPRESS WARRANTY OR CONDITION WHETHER WRITTEN OR ORAL AND HP EXPRESSLY DISCLAIMS ALL WARRANTIES AND CONDITIONS NOT STATED IN THIS LIMITED WARRANTY. TO THE EXTENT ALLOWED BY THE LOCAL LAW OF JURISDICTIONS OUTSIDE THE UNITED STATES, HP DISCLAIMS ALL IMPLIED WARRANTIES OR CONDITIONS, INCLUDING ANY IMPLIED WARRANTIES OF MERCHANTABILITY AND FITNESS FOR A PARTICULAR PURPOSE. FOR ALL TRANSACTIONS OCCURRING IN THE UNITED STATES, ANY IMPLIED WARRANTY OR CONDITION OF MERCHANTABILITY, SATISFACTORY QUALITY, OR FITNESS FOR A PARTICULAR PURPOSE IS LIMITED TO THE DURATION OF THE EXPRESS WARRANTY SET FORTH ABOVE. SOME STATES OR COUNTRIES/REGIONS DO NOT ALLOW A LIMITATION ON HOW LONG AN IMPLIED WARRANTY LASTS OR THE EXCLUSION OR LIMITATION OF INCIDENTAL OR CONSEQUENTIAL DAMAGES FOR CONSUMER PRODUCTS. IN SUCH STATES OR COUNTRIES/REGIONS, SOME EXCLUSIONS OR LIMITATIONS OF THIS LIMITED WARRANTY MAY NOT APPLY TO YOU.

FOR CONSUMER TRANSACTIONS IN AUSTRALIA AND NEW ZEALAND, THE LIMITED WARRANTY TERMS CONTAINED IN THIS STATEMENT, EXCEPT TO THE EXTENT LAWFULLY PERMITTED, DO NOT EXCLUDE, RESTRICT, OR MODIFY BUT ARE IN ADDITION TO THE MANDATORY STATUTORY RIGHTS APPLICABLE TO THE SALE OF THIS PRODUCT TO YOU.

THE LIMITED WARRANTY TERMS CONTAINED IN THIS STATEMENT, EXCEPT TO THE EXTENT LAWFULLY PERMITTED, DO NOT EXCLUDE, RESTRICT, OR MODIFY BUT ARE IN ADDITION TO THE MANDATORY STATUTORY RIGHTS APPLICABLE TO THE SALE OF THIS PRODUCT TO YOU.

This Limited Warranty is applicable in all countries/regions and may be enforced in any country/region where HP or its authorized service providers offer warranty service for the same product model number subject to the terms and conditions set forth in this Limited Warranty.

Under the HP Global Limited Warranty program, products purchased in one country/region may be transferred to another country/region, where HP or its authorized service providers offer warranty service for the same product model number, without voiding the warranty. Warranty terms, service availability, and service response times may vary from country/region to country/region. Standard warranty service response time is subject to change due to local parts availability. If so, your HP-authorized service provider can provide you with details.

HP is not responsible for any tariffs or duties that may be incurred in transferring the products. Transfer of the products may be covered by export controls issued by the United States or other governments.

This Limited Warranty applies only to HP-branded and Compaq-branded hardware products (collectively referred to in this Limited Warranty as "HP Hardware Products") sold by or leased from Hewlett-Packard Company, its worldwide subsidiaries, affiliates, authorized resellers, or country/region distributors (collectively referred to in this Limited Warranty as "HP") with this Limited Warranty. The term "HP Hardware Product" is limited to the hardware components and required firmware. The term "HP Hardware Product" DOES NOT include any software applications or programs; non-HP products or non-HP-branded peripherals. All non-HP products or non-HP-branded peripherals external to the HP Hardware Product — such as external storage subsystems, displays, printers, and other peripherals — are provided "AS IS" without HP warranty. However, non-HP manufacturers and suppliers, or publishers may provide their own warranties directly to you.

HP warrants that the HP Hardware Products that you have purchased or leased from HP are free from defects in materials or workmanship under normal use during the Limited Warranty Period. The Limited Warranty Period starts on the date of purchase or lease from HP, or from the date HP completes installation. Your dated sales or delivery receipt, showing the date of purchase or lease of the product, is your proof of the purchase or lease date. You may be required to provide proof of purchase or lease as a condition of receiving warranty service. You are entitled to hardware warranty service according to the terms and conditions of this document if a repair to your HP Hardware Product is required within the Limited Warranty Period.

Unless otherwise stated, and to the extent permitted by local law, new HP Hardware Products may be manufactured using new materials or new and used materials equivalent to new in performance and reliability. HP may repair or replace HP Hardware Products (a) with new or previously used products or parts equivalent to new in performance and reliability, or (b) with equivalent products to an original product that has been discontinued. Replacement parts are warranted to be free from defects in material or workmanship for ninety (90) days or, for the remainder of the Limited Warranty Period of the HP Hardware Product they are replacing or in which they are installed, whichever is longer.

HP will, at its discretion, repair or replace any component or hardware product that manifests a defect in materials or workmanship during the Limited Warranty Period. All component parts or hardware products removed under this Limited Warranty become the property of HP. In the unlikely event that your HP Hardware Product has recurring failures, HP, at its sole discretion, may elect to provide you with (a) a replacement unit of HP's choosing that is the same or equivalent to your HP Hardware Product in performance or (b) to give you a refund of your purchase price or lease payments (less interest) instead of a replacement. This is your exclusive remedy for defective products.

## **Exclusions**

HP DOES NOT WARRANT THAT THE OPERATION OF THIS PRODUCT WILL BE UNINTERRUPTED OR ERROR-FREE. HP IS NOT RESPONSIBLE FOR DAMAGE THAT OCCURS AS A RESULT OF YOUR FAILURE TO FOLLOW THE INSTRUCTIONS INTENDED FOR THE HP HARDWARE PRODUCT.

This Limited Warranty does not apply to expendable or consumable parts and does not extend to any product from which the serial number has been removed or that has been damaged or rendered defective (a) as a result of accident, misuse, abuse, contamination, improper or inadequate maintenance or calibration or other external causes; (b) by operation outside the usage parameters stated in the user documentation that shipped with the product; (c) by software, interfacing, parts or supplies not supplied by HP; (d) improper site preparation or maintenance; (e) virus infection; (f) loss or damage in transit; or (g) by modification or service by anyone other than (i) HP, (ii) an HP authorized service provider, or (iii) your own installation of end-user-replaceable HP or HP approved parts if available for your product in the servicing country/region.

**YOU SHOULD MAKE PERIODIC BACKUP COPIES OF THE DATA STORED ON YOUR HARD DRIVE OR OTHER STORAGE DEVICES AS A PRECAUTION AGAINST POSSIBLE FAILURES, ALTERATION, OR LOSS OF THE DATA. BEFORE RETURNING ANY UNIT FOR SERVICE, BE SURE TO BACK UP DATA AND REMOVE ANY CONFIDENTIAL, PROPRIETARY, OR PERSONAL INFORMATION. HP IS NOT RESPONSIBLE FOR DAMAGE TO OR LOSS OF ANY PROGRAMS, DATA, OR REMOVABLE STORAGE MEDIA. HP IS NOT RESPONSIBLE FOR THE RESTORATION OR REINSTALLATION OF ANY PROGRAMS OR DATA OTHER THAN SOFTWARE INSTALLED BY HP WHEN THE PRODUCT IS MANUFACTURED. UNITS SENT IN FOR SERVICE MAY HAVE THE DATA ERASED FROM THE HARD DRIVE AND THE PROGRAMS RESTORED TO THEIR ORIGINAL STATE.**



## **Exclusive Remedy**

TO THE EXTENT ALLOWED BY APPLICABLE LOCAL LAW, THESE TERMS AND CONDITIONS CONSTITUTE THE COMPLETE AND EXCLUSIVE WARRANTY AGREEMENT BETWEEN YOU AND HP REGARDING THE HP HARDWARE PRODUCT YOU HAVE PURCHASED OR LEASED. THESE TERMS AND CONDITIONS SUPERSEDE ANY PRIOR AGREEMENTS OR REPRESENTATIONS — INCLUDING REPRESENTATIONS MADE IN HP SALES LITERATURE OR ADVICE GIVEN TO YOU BY HP OR AN AGENT OR EMPLOYEE OF HP — THAT MAY HAVE BEEN MADE IN CONNECTION WITH YOUR PURCHASE OR LEASE OF THE HP HARDWARE PRODUCT. No change to the conditions of this limited warranty is valid unless it is made in writing and signed by an authorized representative of HP.

## **Limitation of Liability**

IF YOUR HP HARDWARE PRODUCT FAILS TO WORK AS WARRANTED ABOVE, HP'S MAXIMUM LIABILITY UNDER THIS LIMITED WARRANTY IS EXPRESSLY LIMITED TO THE LESSER OF THE PRICE YOU HAVE PAID FOR THE PRODUCT OR THE COST OF REPAIR OR REPLACEMENT OF ANY HARDWARE COMPONENTS THAT MALFUNCTION IN CONDITIONS OF NORMAL USE.

EXCEPT AS INDICATED ABOVE, IN NO EVENT WILL HP BE LIABLE FOR ANY DAMAGES CAUSED BY THE PRODUCT OR THE FAILURE OF THE PRODUCT TO PERFORM, INCLUDING ANY LOST PROFITS OR SAVINGS OR SPECIAL, INCIDENTAL, OR CONSEQUENTIAL DAMAGES. HP IS NOT LIABLE FOR ANY CLAIM MADE BY A THIRD PARTY OR MADE BY YOU FOR A THIRD PARTY.

THIS LIMITATION OF LIABILITY APPLIES WHETHER DAMAGES ARE SOUGHT, OR A CLAIM MADE, UNDER THIS LIMITED WARRANTY OR AS A TORT CLAIM (INCLUDING NEGLIGENCE AND STRICT PRODUCT LIABILITY), A CONTRACT CLAIM, OR ANY OTHER CLAIM. THIS LIMITATION OF LIABILITY CANNOT BE WAIVED OR AMENDED BY ANY PERSON. THIS LIMITATION OF LIABILITY WILL BE EFFECTIVE EVEN IF YOU HAVE ADVISED HP OR AN AUTHORIZED REPRESENTATIVE OF HP OF THE POSSIBILITY OF ANY SUCH DAMAGES. THIS LIMITATION OF LIABILITY, HOWEVER, WILL NOT APPLY TO CLAIMS FOR PERSONAL INJURY.

THIS LIMITED WARRANTY GIVES YOU SPECIFIC LEGAL RIGHTS. YOU MAY ALSO HAVE OTHER RIGHTS THAT MAY VARY FROM STATE TO STATE OR FROM COUNTRY/REGION TO COUNTRY/REGION. YOU ARE ADVISED TO CONSULT APPLICABLE STATE OR COUNTRY/REGION LAWS FOR A FULL DETERMINATION OF YOUR RIGHTS.

## **Limited Warranty Period**

The Limited Warranty Period for an HP Hardware Product is a specified, fixed period commencing on the date of purchase. The date on your sales receipt is the date of purchase unless HP or your reseller informs you otherwise in writing.

## **Types of Warranty Service**

To enable HP to provide the best possible support and service during the Limited Warranty Period, you may be directed by HP to verify configurations, load most recent firmware, install software patches, run HP diagnostics tests or use HP remote support solutions where applicable.

HP strongly encourages you to accept the use of or to employ available support technologies provided by HP. If you choose not to deploy available remote support capabilities, you may incur additional costs due to increased support resource requirements. Listed below are the types of warranty support service that may be applicable to the HP Hardware Product you have purchased.

### **On-Site Warranty Service**

Your HP Limited Warranty service may include on-site labor support to repair your hardware. HP provides on-site service during standard office hours. Standard office hours are typically 08.00 to 17.00, Monday through Friday, but may vary with local business practices. If your location is outside the customary service zone (typically 50km), response times may be longer or there may be additional charges. To locate the nearest HP authorized service provider refer to the HP Web site at:

**<http://www.hp.com/hk/support>**

*Or*

**<http://www.hp.com.tw/support>**

HP may, at its sole discretion, determine if on-site warranty service is required. For example, in many cases, the defect can be fixed by the use of a Customer Self Repair (CSR) part that you are required to replace yourself based on instructions and documentation provided by HP. You are also required to co-operate with HP in attempting to resolve the problem over the telephone. This may involve performing routine diagnostic procedures, installing software updates or patches, removing third-party options and/or substituting options. In order to receive onsite support, you must: (a) have a representative present when HP provides warranty services at your site; (b) notify HP if products are being used in an environment which poses a potential health or safety hazard to HP employees or subcontractors; (c) subject to its reasonable security requirements, provide HP with sufficient, free, and safe access to and use of all facilities, information and systems determined necessary by HP to provide timely support; (d) ensure that all manufacturer's labels (such as serial numbers) are in place, accessible, and legible; (e) maintain an environment consistent with product specifications and supported configurations.

If you require an HP representative to handle all component replacements, support uplift contracts are available at additional cost.

## **Carry-in Warranty Service**

Under the terms of carry-in service, you will be required to deliver your HP Hardware Product to an authorized service location for warranty repair. You must prepay any shipping charges, taxes, or duties associated with transportation of the product to and from the service location. In addition, you are responsible for insuring any product shipped or returned to an authorized service location and assume risk of loss during shipping.

## **Mail-in Warranty Service**

Your HP Limited Warranty may include a mail-in warranty service. Under the terms of mail-in service, you will be required to ship your HP Hardware Product to an authorized service location for warranty repair. You must prepay any shipping charges, taxes, or duties associated with transportation of the product to the repair location. In addition, you are responsible for insuring any product you ship and assume risk of loss during shipping. HP will return the repaired product to you and incur all logistics and insurance costs to return the product to you.

## **Pick Up and Return Warranty Service**

Your HP Limited Warranty may include a pick up and return warranty service. Under the terms of pick up and return service, HP will pick up the defective unit from your location, repair it and return it back to your location. HP will incur all repair, logistics, and insurance costs in this process.

## **Customer Self Repair Warranty Service**

In countries/regions where it is available, your HP Limited Warranty may include a customer self repair warranty service. If applicable, HP will determine in its sole discretion that customer self repair is the appropriate method of warranty service. If so, HP will ship approved replacement parts directly to you to fulfill your HP Hardware Product warranty service. This will save considerable repair time. After you contact HP and the fault diagnosis identifies that the problem can be fixed using one of these parts, a replaceable part can be sent directly to you. Once the part arrives, replace the defective part pursuant to the provided instructions and documentation. If further assistance is required, call the HP Technical Support Center and a technician will assist you over the phone. In cases where the replacement part must be returned to HP, you must ship the defective part back to HP within a defined period of time, normally fifteen (15) days. The defective part must be returned with the associated documentation in the provided shipping material. Failure to return the defective product may result in HP billing you for the replacement. With a customer self repair, HP will pay all shipping and part return costs and determine the courier/carrier to be used. If customer self repair applies to you, please refer to your specific HP Hardware Product announcement. You can also obtain information on this warranty service on the HP Web site at:

**<http://www.hp.com/hk/support>**

Or

**<http://www.hp.com.tw/support>**

## Service Upgrades

HP has a range of additional support and service coverage for your product that can be purchased locally. However, some support and related products may not be available in all countries/regions. For information on availability of service upgrades and the cost for these service upgrades, refer to the HP Web site at:

<http://www.hp.com/hk/support>

Or

<http://www.hp.com.tw/support>

## Options and Software Limited Warranties

The Limited Warranty terms and conditions for most HP-branded options (HP Options) are as set forth in the Limited Warranty applicable to the HP Option and are included in the HP Option product packaging. If your HP Option is installed in an HP Hardware Product, HP may provide warranty service for either the period specified in the warranty documents (HP Option Limited Warranty Period) that shipped with the HP Option or for the remaining warranty period of the HP Hardware Product in which the HP Option is being installed, whichever period is the longer, but not to exceed three (3) years from the date you purchased the HP Option. The HP Option Limited Warranty Period starts from the date of purchase from HP or an HP-authorized reseller. Your dated sales or delivery receipt, showing the date of purchase of the HP Option, is your warranty start date. See your HP Option Limited Warranty for more details. Non-HP options are provided "AS IS". However, non-HP manufacturers and suppliers may provide warranties directly to you.

EXCEPT AS PROVIDED IN THE APPLICABLE SOFTWARE END-USER LICENSE OR PROGRAM LICENSE AGREEMENT, OR IF OTHERWISE PROVIDED UNDER LOCAL LAW, SOFTWARE PRODUCTS, INCLUDING ANY SOFTWARE PRODUCTS, FREWARE (AS DEFINED BELOW) OR THE OPERATING SYSTEM PREINSTALLED BY HP ARE PROVIDED "AS IS" AND WITH ALL FAULTS, AND HP HEREBY DISCLAIMS ALL OTHER WARRANTIES AND CONDITIONS, EITHER EXPRESS, IMPLIED, OR STATUTORY, INCLUDING, BUT NOT LIMITED TO, WARRANTIES OF TITLE AND NON-INFRINGEMENT, ANY IMPLIED WARRANTIES, DUTIES OR CONDITIONS OF MERCHANTABILITY, OF FITNESS FOR A PARTICULAR PURPOSE, AND OF LACK OF VIRUSES. Some states/jurisdictions do not allow exclusion of implied warranties or limitations on the duration of implied warranties, so the above disclaimer may not apply to you in its entirety. TO THE MAXIMUM EXTENT PERMITTED BY APPLICABLE LAW, IN NO EVENT SHALL HP OR ITS SUPPLIERS BE LIABLE FOR ANY SPECIAL, INCIDENTAL, INDIRECT, OR CONSEQUENTIAL DAMAGES WHATSOEVER (INCLUDING, BUT NOT LIMITED TO, DAMAGES FOR LOSS OF PROFITS OR CONFIDENTIAL OR OTHER INFORMATION, FOR BUSINESS INTERRUPTION, FOR PERSONAL INJURY, FOR LOSS OF PRIVACY ARISING OUT OF OR IN ANY WAY RELATED TO THE USE OF OR INABILITY TO USE THE SOFTWARE PRODUCT), EVEN IF HP OR ANY SUPPLIER HAS BEEN ADVISED OF THE POSSIBILITY OF SUCH DAMAGES AND EVEN IF THE REMEDY FAILS OF ITS ESSENTIAL PURPOSE. Some states/jurisdictions do not allow the exclusion or limitation of incidental or consequential damages, so the above limitation or exclusion may not apply to you.

HP's only warranty obligations with respect to software distributed by HP under the HP brand name are set forth in the applicable end-user license or program license agreement provided with that software. If the removable media on which HP distributes the software proves to be defective in materials or workmanship within thirty (30) days of purchase, your sole remedy shall be to return the removable media to HP for replacement. For blank tape removable media please refer to the following Web site:

**<http://h20000.www2.hp.com/bizsupport/TechSupport/Document.jsp?objectID=lpg50101>**

It is your responsibility to contact non-HP manufacturers or suppliers for their warranty support.

## **Software Technical Support**

Software Technical Support for your HP Software, HP pre-installed third-party software and third-party software purchased from HP is available from HP via multiple contact methods, including electronic media and telephone, for thirty (30) days from date of purchase. See "Contacting HP" for online resources and telephone support. Any exceptions to this will be specified in your End User License Agreement (EULA).

Software Technical Support includes assistance with:

- Answering your installation questions (how-to, first steps, and prerequisites).
- Setting up and configuring the software (how-to and first steps). **Excludes** system optimization, customization and network configuration.
- Interpreting system error messages.
- Isolating system problems to software usage problems.
- Obtaining support pack information or updates.

Software technical support does NOT include assistance with:

- Generating or diagnosing user generated programs or source codes.
- Installation of non-HP products.

## Contacting HP

If your product fails during the Limited Warranty Period and the suggestions in the product documentation do not solve the problem, you can receive support by doing the following:

- Locate your nearest HP Support location via the World Wide Web at:

**<http://www.hp.com/hk/support>**

Or

**<http://www.hp.com.tw/support>**

- Contact your authorized HP dealer or Authorized Service Provider and be sure to have the following information available before you call HP:
  - Product serial number, model name, and model number
  - Applicable error messages
  - Add-on options
  - Operating system
  - Third-party hardware or software
  - Detailed questions

## How to Check Warranty and Support Entitlement

Please check **<http://www.hp.com/hk/support>** or **<http://www.hp.com.tw/support>** for warranty, service and support and product information updates.

## END-USER LICENSE AGREEMENT

PLEASE READ CAREFULLY BEFORE USING THIS EQUIPMENT: This End-User license Agreement ("EULA") is a legal agreement between (a) you (either an individual or a single entity) and (b) Hewlett-Packard Company ("HP") that governs your use of any Software Product, installed on or made available by HP for use with your HP product ("HP Product"), that is not otherwise subject to a separate license agreement between you and HP or its suppliers. Other software may contain a EULA in its online documentation. The term "Software Product" means computer software and may include associated media, printed materials and "online" or electronic documentation. An amendment or addendum to this EULA may accompany the HP Product.

RIGHTS IN THE SOFTWARE PRODUCT ARE OFFERED ONLY ON THE CONDITION THAT YOU AGREE TO ALL TERMS AND CONDITIONS OF THIS EULA. BY INSTALLING, COPYING, DOWNLOADING, OR OTHERWISE USING THE SOFTWARE PRODUCT, YOU AGREE TO BE BOUND BY THE TERMS OF THIS EULA. IF YOU DO NOT ACCEPT THESE LICENSE TERMS, YOUR SOLE REMEDY IS TO RETURN THE ENTIRE UNUSED PRODUCT (HARDWARE AND SOFTWARE) WITHIN 14 DAYS FOR A REFUND SUBJECT TO THE REFUND POLICY OF YOUR PLACE OF PURCHASE.

1. GRANT OF LICENSE. HP grants you the following rights provided you comply with all terms and conditions of this EULA:

a. Use. You may use the Software Product on a single computer ("Your Computer"). If the Software Product is provided to you via the internet and was originally licensed for use on more than one computer, you may install and use the Software Product only on those computers. You may not separate component parts of the Software Product for use on more than one computer. You do not have the right to distribute the Software Product. You may load the Software Product into Your Computer's temporary memory (RAM) for purposes of using the Software Product.

b. Storage. You may copy the Software Product into the local memory or storage device of the HP Product.

c. Copying. You may make archival or back-up copies of the Software Product, provided the copy contains all of the original Software Product's proprietary notices and that it is used only for back-up purposes.

d. Reservation of Rights. HP and its suppliers reserve all rights not expressly granted to you in this EULA.

e. Freeware. Notwithstanding the terms and conditions of this EULA, all or any portion of the Software Product which constitutes non-proprietary HP software or software provided under public license by third parties ("Freeware"), is licensed to you subject to the terms and conditions of the software license agreement accompanying such Freeware whether in the form of a discrete agreement, shrink wrap license or electronic license terms accepted at time of download. Use of the Freeware by you shall be governed entirely by the terms and conditions of such license.

f. Recovery Solution. Any software recovery solution provided with/for your HP Product, whether in the form of a hard disk drive-based solution, an external media-based recovery solution (e.g. floppy disk, CD or DVD) or an equivalent solution delivered in any other form, may only be used for restoring the hard disk of the HP Product with/for which the recovery solution was originally purchased. The use of any Microsoft operating system software contained in such recovery solution shall be governed by the Microsoft License Agreement.

2. UPGRADES. To use a Software Product identified as an upgrade, you must first be licensed for the original Software Product identified by HP as eligible for the upgrade. After upgrading, you may no longer use the original Software Product that formed the basis for your upgrade eligibility.

3. ADDITIONAL SOFTWARE. This EULA applies to updates or supplements to the original Software Product provided by HP unless HP provides other terms along with the update or supplement. In case of a conflict between such terms, the other terms will prevail.

4. TRANSFER.

a. Third Party. The initial user of the Software Product may make a one-time transfer of the Software Product to another end user. Any transfer must include all component parts, media, printed materials, this EULA, and if applicable, the Certificate of Authenticity. The transfer may not be an indirect transfer, such as a consignment. Prior to the transfer, the end user receiving the transferred product must agree to all the EULA terms. Upon transfer of the Software Product, your license is automatically terminated.

b. Restrictions. You may not rent, lease or lend the Software Product or use the Software Product for commercial timesharing or bureau use. You may not sublicense, assign or transfer the license or Software Product except as expressly provided in this EULA.

5. PROPRIETARY RIGHTS. All intellectual property rights in the Software Product and user documentation are owned by HP or its suppliers and are protected by law, including but not limited to United States copyright, trade secret, and trademark law, as well as other applicable laws and international treaty provisions. You shall not remove any product identification, copyright notices or proprietary restrictions from the Software Product.

6. LIMITATION ON REVERSE ENGINEERING. You may not reverse engineer, decompile, or disassemble the Software Product, except and only to the extent that the right to do so is mandated under applicable law notwithstanding this limitation or it is expressly provided for in this EULA.

7. TERM. This EULA is effective unless terminated or rejected. This EULA will also terminate upon conditions set forth elsewhere in this EULA or if you fail to comply with any term or condition of this EULA.

8. CONSENT TO USE OF DATA. You agree that HP and its affiliates may collect and use technical information you provide in relation to support services related to the Software Product. HP agrees not to use this information in a form that personally identifies you except to the extent necessary to provide such services.

9. DISCLAIMER OF WARRANTIES. TO THE MAXIMUM EXTENT PERMITTED BY APPLICABLE LAW, HP AND ITS SUPPLIERS PROVIDE THE SOFTWARE PRODUCT "AS IS" AND WITH ALL FAULTS, AND HEREBY DISCLAIM ALL OTHER WARRANTIES AND CONDITIONS, EITHER EXPRESS, IMPLIED, OR STATUTORY, INCLUDING, BUT NOT LIMITED TO, WARRANTIES OF TITLE AND NON-INFRINGEMENT, ANY IMPLIED WARRANTIES, DUTIES OR CONDITIONS OF MERCHANTABILITY, OF FITNESS FOR A PARTICULAR PURPOSE, AND OF LACK OF VIRUSES ALL WITH REGARD TO THE SOFTWARE PRODUCT. Some states/jurisdictions do not allow exclusion of implied warranties or limitations on the duration of implied warranties, so the above disclaimer may not apply to you in its entirety.

10. LIMITATION OF LIABILITY. Notwithstanding any damages that you might incur, the entire liability of HP and any of its suppliers under any provision of this EULA and your exclusive remedy for all of the foregoing shall be limited to the greater of the amount actually paid by you separately for the Software Product or U.S. \$5.00. TO THE MAXIMUM EXTENT PERMITTED BY APPLICABLE LAW, IN NO EVENT SHALL HP OR ITS SUPPLIERS BE LIABLE FOR ANY SPECIAL, INCIDENTAL, INDIRECT, OR CONSEQUENTIAL DAMAGES WHATSOEVER (INCLUDING, BUT NOT LIMITED TO, DAMAGES FOR LOSS OF PROFITS OR CONFIDENTIAL OR OTHER INFORMATION, FOR BUSINESS INTERRUPTION, FOR PERSONAL INJURY, FOR LOSS OF PRIVACY ARISING OUT OF OR IN ANY WAY RELATED TO THE USE OF OR INABILITY TO USE THE SOFTWARE PRODUCT, OR OTHERWISE IN CONNECTION WITH ANY PROVISION OF THIS EULA, EVEN IF HP OR ANY SUPPLIER HAS BEEN ADVISED OF THE POSSIBILITY OF SUCH DAMAGES AND EVEN IF THE REMEDY FAILS OF ITS ESSENTIAL PURPOSE. Some states/jurisdictions do not allow the exclusion or limitation of incidental or consequential damages, so the above limitation or exclusion may not apply to you.

11. U.S. GOVERNMENT CUSTOMERS. Consistent with FAR 12.211 and 12.212, Commercial Computer Software, Computer Software Documentation, and Technical Data for Commercial Items are licensed to the U.S. Government under HP's standard commercial license.



12. COMPLIANCE WITH EXPORT LAWS. You shall comply with all laws and regulations of the United States and other countries/regions ("Export Laws") to assure that the Software Product is not (1) exported, directly or indirectly, in violation of Export Laws, or (2) used for any purpose prohibited by Export Laws, including, without limitation, nuclear, chemical, or biological weapons proliferation.

13. CAPACITY AND AUTHORITY TO CONTRACT. You represent that you are of the legal age of majority in your state of residence and, if applicable, you are duly authorized by your employer to enter into this contract.

14. APPLICABLE LAW. This EULA is governed by the laws of the State of California, U.S.A.

15. ENTIRE AGREEMENT. This EULA (including any addendum or amendment to this EULA which is included with the HP Product) is the entire agreement between you and HP relating to the Software Product and it supersedes all prior or contemporaneous oral or written communications, proposals and representations with respect to the Software Product or any other subject matter covered by this EULA. To the extent the terms of any HP policies or programs for support services conflict with the terms of this EULA, the terms of this EULA shall control.

Rev. 10/03



# DECLARATION OF CONFORMITY

according to ISO/IEC 17050-1 and EN 17050-1

**Supplier's Name:** Hewlett-Packard Company

**Supplier's Address:** Hewlett-Packard Company  
10955 Tantau Ave  
Cupertino, CA 95014

**declares, that the product(s)**

**Product:** Personal computer

**Model Number(s):** 800, 900  
a000, a1000, a5000, a6000  
CQ2000, CQ5000  
d1000, d4000, dx2000, d5000  
e9000  
g2000, g3000  
m000, m1000, m5000, m7000, m8000, m9000  
p6000  
s0000, s3000, s5000, s7000  
SR1000, SR2000, SR5000, SA4000, SV2000, SV7000,  
SG2000, SG3000  
t000, t3000  
u6000  
v2000, v7000  
w1000, w5000  
x5000, z500, z6000 series

**Product Options:** Modem card: RD01-D850, CX-9Z-NR0134, A40, C40  
Bluetooth: BM-GP-BR-51  
TV Tuner  
card: 71xxx, 74xxx, 78xxx, 26xxx, 25xxx,  
JayHawk, Fennec, Twolf  
Keyboard: 51xx, 5335U, KB-06xx, KB-09xx,  
KBPH-0806, KM713A, KG-0851, KU-0841,  
SK806A, SK29xx, I101-P01, PR11-01,  
PR1101U, RK713A, 9131URF, 5189URF,  
KBRF1921  
Mouse: KM713A, RM713A, M389, M889,  
MG-0856, MOAFUO, MOBJKC, MOBJKO,  
MOBLUL, MODGUO, M-SBQ133,  
M-SBP133, M-SBF96, M-U0009-HP1,  
MSPO-0701, M60PB, N17RBP,  
N17ROPKYE, 9131URF, 5189URF,  
MORFB1UO, UAE96, MORFDIUO, N910U

**conforms to the following Product Specifications:**

<b>Safety:</b>	IEC 60950-1:2001 / EN60950-1: 2001 EN 60825-1: 1994 + A1: 2002 + A2: 2001, Class 1 (Laser/LED)
<b>EMC:</b>	CISPR 22: 1997 / EN 55022: 1998 +A1:2000 +A2:2003, Class B/ EN 55022:2006, Class B CISPR 24: 1997 / EN 55024:+1998 +A1:2001 +A2:2003 EN 55020:1995/ EN 55020:2002 +A1:2002 + A2:2005 EN 55013:2001 +A1:2003 EN 61000-3-2: 2006, Class D EN 61000-3-3: 1995 + A1: 2001+ A2:2005 FCC Title 47 CFR, Part 15 Class B / ICES-003 AS/NZS CISPR 22: 2004/ AS/NZS CISPR 22: 2006
<b>Telecom:</b>	TBR 21: 1998 EN 300328: V.1.7.1, Technical requirements for Radio equipment

**Supplementary Information:**

The product herewith complies with the requirements of the Low Voltage Directive 2006/95/EC, the EMC Directive 2004/108/EEC and the R&TTE Directive 99/5/EC and carries the "CE Marking" accordingly.

This device complies with Part 15 of FCC rules. Operation is subject to the following two conditions: (1) this device may not cause harmful interference, and (2) this device must accept any interference received, including interference that may cause undesired operation.

Cupertino, CA USA

December 3, 2008

**For regulatory compliance information only, contact:**

Australia Contact: Product Regulations Manager, Hewlett-Packard Australia Pty Ltd.,  
31-41 Joseph Street, Blackburn, Victoria 3130

European Contact: Hewlett-Packard GmbH, HQ-TRE, Herrenberger Straße 140,  
71034 Böblingen, Germany

North America Contact: Hardware Quality Eng. Manager, Hewlett-Packard, CPC,  
10955 Tantau Ave., Cupertino, CA 95014

# Operating Specifications

<b>Electrical ratings:</b>	AC INPUT	100–127V $\surd$ , 3A or 4A or 6A* 200–240V $\surd$ , 2A or 3A*
	50/60 Hz	
<b>Operating temperature:</b>	5° to 35° C	
<b>Storage temperature:</b>	–30° to 65° C	
<b>Operating humidity:</b>	15 to 80% @ 26° C	
<b>Operating altitude:</b>	0–2000 m	
<b>Storage altitude:</b>	0–4572 m	

\* Refer to your computer's ratings label located on the back of the computer to determine exact electrical rating.

## Regulatory and Safety Information



**WARNING:** Text set off in this manner indicates that failure to follow directions could result in damage to equipment, loss of information, bodily harm, or loss of life.

- **Energized and moving parts inside. Disconnect power to the equipment before removing the enclosure.**
- **Replace and secure the enclosure before re-energizing the equipment.**
- **The computer is heavy; be sure to use ergonomically correct lifting procedures when moving the computer.**
- **Please read the "Additional Safety Information" located later in this document before installing and connecting your computer to the electrical power system.**

Batteries are delivered with this product. When empty, do not throw them away but collect as small chemical waste.

### Chemical Substances

HP is committed to providing our customers with information about the chemical substances in our products as needed to comply with legal requirements such as REACH (*Regulation EC No 1907/2006 of the European Parliament and the Council*). A chemical information report for this product can be found at: <http://www.hp.com/go/reach>

## Important Information About ENERGY STAR

HP computers marked with the ENERGY STAR® Logo are compliant with the applicable U.S. Environmental Protection Agency (EPA) ENERGY STAR specifications for computers. The EPA ENERGY STAR Logo does not imply endorsement by the EPA. As an ENERGY STAR Partner, Hewlett-Packard Company has determined the products marked with the ENERGY STAR Logo are ENERGY STAR qualified as per the applicable ENERGY STAR guidelines for energy efficiency. The following logo will appear on all ENERGY STAR qualified computers:



The ENERGY STAR Computers Program was created by the EPA to promote energy efficiency and reduce air pollution through more energy-efficient equipment in homes, offices, and factories. One way products achieve this is by reducing power consumption when not being used through the Microsoft Windows® Power Management feature.

The Power Management feature allows the computer to enter into a low-power or “sleep” mode after a period of user inactivity. When used with an external ENERGY STAR compliant monitor, this feature will also support similar power management features of the monitor. To take advantage of this energy savings:

- The Power Management feature has been preset to power down the computer after 20 minutes of user inactivity.
- The Power Management feature has been preset to power down the monitor after 15 minutes of user inactivity.

Both the computer and monitor can be woken from “sleep” mode through user interaction with any of the computer’s input devices (ex: mouse, keyboard, etc). When configured with Wake On LAN (WOL) enabled, the computer can also be awoken by a network signal.

More information on the energy and financial savings potential of the Power Management Feature can be found at the EPA’s ENERGY STAR Power Management Web site:

**[www.energystar.gov/powermanagement](http://www.energystar.gov/powermanagement)**

More information on the ENERGY STAR program and its environmental benefits are available by visiting the EPA’s ENERGY STAR Web site address: **[www.energystar.gov](http://www.energystar.gov)**



**CAUTION: Using the Energy Save Monitor feature with non-ENERGY STAR compliant monitors may cause video distortion when the Energy Save timeout occurs.**

## Audio Volume Statement

Listening to music at high volume levels and for extended durations may damage one's hearing. In order to reduce the risk of damage to hearing, one should lower the volume to a safe, comfortable level, and reduce the amount of time listening at high levels.

- For your own safety, before using headsets or earphones, always reset the volume. Some headphones are louder than other headphones, even if the volume control setting is the same.
- Changing the default audio or equalizer settings might lead to higher volume and should only be done with caution.
- If one HP product number includes a computer along with a headset or earphone, this combination is in compliance with EN 50332-1.
- In general, audio line-out I/F is not intended to be used with a headset or earphone.



**WARNING: When using this device, basic safety precautions should always be followed to reduce the risk of fire, electric shock, and injury to persons, including the following:**

- **Do not use this product near water; for example, near a bathtub, wash bowl, kitchen sink, or laundry tub, in a wet basement, or near a swimming pool.**
- **Avoid using this product during an electrical storm. There may be a remote risk of electric shock from lightning.**
- **Do not use this product to report a gas leak in the vicinity of the leak.**
- **Always disconnect the modem cable before opening the equipment enclosure or touching an uninsulated modem cable, jack, or internal components.**
- **If this product was not provided with a telephone line cord, use only No. 26 AWG or larger telecommunication line cord in order to reduce the risk of fire.**
- **Do not plug a modem or telephone cable into the Network Interface Card (NIC) receptacle.**

**SAVE THESE INSTRUCTIONS**

---

## Additional Safety Information

This product has not been evaluated for connection to an “IT” power system (an AC distribution system with no direct connection to earth, according to IEC 60950).

### AC Power Safety Warning

---



**WARNING:** Install the computer near an AC outlet. The AC power cord is your computer’s main AC disconnecting device and must be easily accessible at all times. For your safety, the power cord provided with your computer has a grounded plug. Always use the power cord with a properly grounded wall outlet, to avoid the risk of electrical shock.

Your computer is provided with a voltage select switch for use in a 115 or 230 V<sub>~</sub> power system. The voltage select switch has been pre-set to the correct voltage setting for use in the particular country/region where it was initially sold. Changing the voltage select switch to the incorrect position can damage your computer and void any implied warranty.

To reduce the possibility of an electric shock from the telephone network, plug your computer into the AC outlet before connecting it to the telephone line. Also, disconnect the telephone line before unplugging your computer from the AC power outlet.

Always disconnect the modem cord from the telephone system before installing or removing your computer cover.

Do not operate the computer with the cover removed.

For your safety, always unplug the computer from its power source and from any telecommunications systems (such as telephone lines), networks, or modems before performing any service procedures. Failure to do so may result in personal injury or equipment damage. Hazardous voltage levels are inside the power supply and modem of this product.

---

### Lithium Battery Caution

---



**WARNING:** The computer uses a lithium battery, type CR2032. There is danger of an explosion if the battery is incorrectly replaced. Replace only with the same, or equivalent, type recommended by the manufacturer. Dispose of used batteries according to the manufacturer’s instructions.

---

## Laser Safety Statement

### Class 1 LED Product

The CD and DVD drives contain a laser system and are classified as a "Class 1 Laser Product" under a U.S. Department of Health and Human Services (DHHS) Radiation Performance standard according to the Radiation Control for Health and Safety Act of 1968.

Should the unit ever require maintenance, contact an authorized service location.



**WARNING: Use of controls, adjustments, or performance procedures other than those specified in the *Upgrading and Servicing Guide* may result in hazardous radiation exposure. To prevent direct exposure to laser beam, do not try to open the enclosure of the CD or DVD drives.**

---

### Laser Product Label

The following label or equivalent is located on the surface of laser products:



This label indicates that the product is classified as a CLASS 1 LASER PRODUCT. This label appears on a laser device installed in your product.

## TV Antenna Connectors Protection

### External Television Antenna Grounding

If an outside antenna or cable system is connected to the product, be sure the antenna or cable system is electrically grounded so as to provide some protection against voltage surges and built-up static charges. Article 810 of the National Electrical Code, ANSI/NFPA 70, provides information with regard to proper electrical grounding of the mast and supporting structure, grounding of the lead-in wire to an antenna-discharge unit, size of grounding conductors, location of antenna-discharge unit, connection to grounding electrodes, and requirements for the grounding electrode.



## Lightning Protection

For added protection of any product during a lightning storm, or when it is left unattended and unused for long periods of time, unplug the product from the wall outlet and disconnect the antenna or cable system. This will prevent damage to the product from lightning and power line surges.

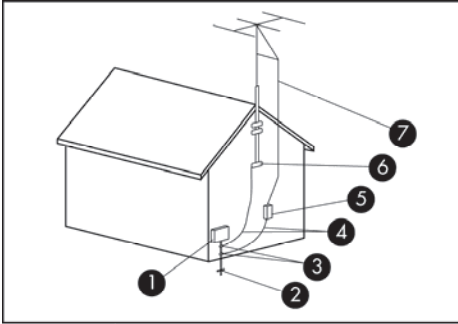

Antenna Grounding	
Reference	Grounding Component
1	Electric Service Equipment
2	Power Service Grounding Electrode System (NEC Art 250, Part H)
3	Ground Clamps
4	Grounding Conductors (NEC Section 810-21)
5	Antenna Discharge Unit (NEC Section 810-20)
6	Ground Clamp
7	Antenna Lead in Wire

Antenna Grounding

## Power Lines

An outside antenna system should not be located in the vicinity of overhead power lines or other electric light or power circuits, or where it can fall into such power lines or circuits.



**WARNING: When installing an outside antenna system, extreme care should be taken to keep from touching such power lines or circuits as contact with them could be fatal.**

# Support Information

## Don't Forget to Register!

Go to: <http://www.hp.com/apac/register>

## Where to Get Help

### Follow These Steps When You Need Help:

- 1 Check the setup poster and product documentation for help with setting up and using your computer.
- 2 Use the Help and Support Center for help with hardware and software questions. Click **Start**, and then click **Help and Support**. The Help and Support Center provides useful troubleshooting information and includes the following:
  - E-mail support.
  - HP Real Time Chat with qualified support specialists.
  - Support phone numbers.
- 3 If you think you have a hardware issue, before calling the Customer Care Center, run the hardware diagnostic tools that are preinstalled on your computer. Click **Start, All Programs, PC Help & Tools**, and then click **Hardware Diagnostic Tools**.
- 4 For help online, go to the HP Customer Care Center Web site at:  
<http://www.hp.com/hk/support>  
Or  
<http://www.hp.com.tw/support>  
for technical information or to get software updates.
- 5 If you have not solved the problem, call the HP Customer Care Center at the appropriate number below.  
**Hong Kong SAR: 2802 4098**  
**Macau SAR: 0800 366**  
Hours: Mon.–Fri. 9 a.m.–6 p.m., Sat. 9 a.m.–1 p.m.  
**Taiwan: 0800 095 996**  
Hours: Mon.–Sat. 8:30 a.m.–9 p.m.  
(Hours are subject to change without notice.)

### HP Support Web site

<http://www.hp.com/hk/support>

Or

<http://www.hp.com.tw/support>

## To Our Valued Customer

Congratulations on your decision to purchase a Desktop computer! During development, the computer must pass extensive quality tests to meet the rigorous standards that have made us famous for quality and reliability.

All of our computers go through a comprehensive quality test to ensure the computer is working correctly before it leaves our factory. In addition, we have placed a security seal on your computer to indicate that it has not been tampered with since it left our factory.

We know that expanding and upgrading are key benefits for all customers. We are proud to make this a key differentiator for our computers and understand that you may wish to upgrade your computer to meet your specific needs.

Any hardware upgrades that you intend to do should only be done after you have completely set up your new computer. Refer to the setup poster included with your system for help with setting up. If you have any problems setting up your system and turning it on, immediately contact the HP Customer Care Center listed earlier in this *Limited Warranty and Support Guide*, and a HP Customer Representative will assist you. This must be done first before attempting to upgrade your system.

By breaking the security seal on the back of the computer, you are confirming that the computer was working properly before you attempted to upgrade your system. Once the security seal has been broken, your computer is then, to the extent allowed by local law, covered under the terms and conditions listed in the "Hardware Limited Warranty" section.

Thank you for choosing this computer. We hope you enjoy discovering the exciting things you can do with it!

## Customer Support

Easy to reach. Easy to use. Award-winning HP Customer Support is our promise to help you get the most from your computer. Whether with tools located on your computer, from information on the Web, by phone, or through your local retailer, you'll find what you need.

## Problems? HP Will Help

Your new computer is built to work right now — and for many years to come. But it is a complex, powerful machine, and sometimes things go wrong. If that happens to your computer, HP is ready to help.

## Getting Started

Follow the setup poster and the *Getting Started* guide for help with setting up and using your computer.

## See What You Can Do

There's lots of helpful information included with your computer. First look at Help on your Windows desktop (to access it, click **Start**, then click **Help and Support**). It contains more detailed help and will give you suggestions on how to fix the problem.

Within the Help and Support Center, you can get the latest news from HP about your computer. Be sure to also check the updates from HP that are sent to your desktop from time to time.

Next, try a little surfing! The HP Web site has updated software, tips and tricks, answers for common problems, and other information. Go to the Support Web site listed earlier in this document and search for your computer model.

## Call HP Customer Care Center

Finally, if these steps don't help, you can reach a real, knowledgeable person by calling the HP Customer Care Center in your area. Phone assistance to get you up and running is covered for thirty (30) days from the time you purchased your computer. After thirty (30) days, there may be a charge, but the helpful support is still available.

## And, if Necessary: Get Repair

If your computer needs to be repaired or to have parts replaced, you have two choices:

- You can easily replace many of your computer parts that are considered consumer replaceable. This is the fastest method of repair, as many times we can send the part directly to your home or business in a few days.
- If a repair is necessary, the HP Customer Care Center will make arrangements to fix your computer.

These services are covered during the warranty period.

There are a few limitations and exclusions to this warranty (as well as some important details), which are described in the "Hardware Limited Warranty" section.

## Understanding Hard Disk Drive Space

The hard disk drive on the Hewlett-Packard and Compaq computers with the Microsoft Windows operating system preinstalled may appear to be smaller than what is stated in the product specifications, in the documentation, or on the box. Hard disk drives are described and advertised by manufacturers in terms of decimal (base 10) capacity. Microsoft Windows and other programs, such as FDISK, use the binary (base 2) numbering system.

In decimal notation, one megabyte (MB) is equal to 1,000,000 bytes, and one gigabyte (GB) is equal to 1,000,000,000 bytes. In the binary numbering system, one megabyte is equal to 1,048,576 bytes, and one gigabyte is equal to 1,073,741,824 bytes. Because of the different measuring systems, you may see a difference between the size reported by Microsoft Windows and the size advertised. The storage capacity of the hard disk drive is as advertised.

Microsoft Windows reports smaller capacity in the Windows Explorer tool and in the Computer window because it shows information about one partition on the hard disk drive at a time. One of the partitions contains the system recovery information.

## Note About Systems Configured with 4GB of Memory

For computers with a 32-bit operating system, all memory above 3GB may not be available because of system resource requirements.

This limitation is not limited to HP and Compaq systems. The memory above 3GB is used for system resources.

## Confirming Total Memory

The system BIOS displays the full 4GB of installed memory.

- 1 Turn on the PC.
- 2 Press the F1 key. The BIOS menu displays. Confirm the Total Installed Memory.

The information contained herein is subject to change without notice.

Copyright © 2008–2009 Hewlett-Packard Development Company, L.P.





Printed in

