



HP 2310mfa/2310mfd LCD Multifunction Monitor  
User Guide

© 2009, 2010 Hewlett-Packard Development Company, L.P.

Microsoft, Windows, and Windows Vista are either trademarks or registered trademarks of Microsoft Corporation in the United States and/or other countries.

The only warranties for HP products and services are set forth in the express warranty statements accompanying such products and services. Nothing herein should be construed as constituting an additional warranty. HP shall not be liable for technical or editorial errors or omissions contained herein.

This document contains proprietary information that is protected by copyright. No part of this document may be photocopied, reproduced, or translated to another language without the prior written consent of Hewlett-Packard Company.



Second Edition (March 2010)

Document Part Number: 588382-002

# TABLE OF CONTENT

FOR YOUR SAFETY .....	3
PRECAUTIONS AND REMINDERS .....	4
IMPORTANT SAFETY INSTRUCTIONS .....	5
PACKAGE CONTENTS.....	7
SETTING UP THE MFM .....	8
ATTACHING THE BASE .....	8
PREPARING THE MFM FOR WALL MOUNTING .....	8
SELECTING A GOOD LOCATION.....	9
INSTALLING THE MONITOR DRIVER .....	10
INSTALLING THE DRIVER.....	10
DOWNLOADING UPDATED DRIVERS FROM THE INTERNET .....	10
LOCATING THE MFM CONNECTORS AND CONTROLS .....	11
FRONT PANEL CONTROLS .....	13
USING THE REMOTE CONTROL.....	14
VIEWING MODE ILLUSTRATIONS.....	16
CONNECTING TO THE MFM.....	17
BACK CONNECTIONS.....	17
SIDE CONNECTIONS.....	19
CONNECTING AN HDMI OR A DVI DEVICE.....	20
CONNECTING AN HDMI DEVICE .....	20
CONNECTING A DVI DEVICE.....	21
CONNECTING A COMPUTER .....	21
SELECTING THE INPUT SOURCE.....	22
USING THE OSD MENUS.....	22
FOR ATV MODEL.....	22
• FEATURES MENU.....	24
• INSTALLATION .....	26
• PICTURE MENU .....	22
• SOUND MENU .....	23
FOR DTV MODEL .....	28
• FEATURES MENU.....	31
• PARENTAL MENU.....	31
• PICTURE MENU .....	28
• SOUND MENU.....	29
• TV MENU .....	30

LEGAL NOTICES.....	32
TECHNICAL SPECIFICATIONS.....	33
TROUBLESHOOTING.....	36
TIPS .....	37
GLOSSARY .....	37

SYMBOL	SYMBOL DEFINITION
 SA 1965	<b>DANGEROUS VOLTAGE:</b> The lightning flash with arrowhead symbol, within an equilateral triangle, is intended to alert the user to the presence of uninsulated “dangerous voltage” within the product’s enclosure that may be of sufficient magnitude to constitute a risk of electrical shock to persons.
 SA 1966	<b>INSTRUCTIONS:</b> The exclamation point within an equilateral triangle to alert the user to the presence of important operating and maintenance (servicing) instruction in the literature accompanying the appliance.

### Batteries installed warning

 **Warning** - Danger of explosion if battery is incorrectly replaced. Replace only with the same or equivalent type.

The batteries (battery pack or batteries installed) should not be exposed to excessive heat such as sunlight, fire or the like.

## FOR YOUR SAFETY

Before operating the HP multifunction monitor (MFM) please read this manual thoroughly. This manual should be retained for future reference.







### NOTICE

1. The changes or modifications not expressly approved by the party responsible for compliance could void the user's authority to operate the equipment.
2. Shielded interface cables and AC power cord, if any, must be used in order to comply with the emission limits.
3. The manufacturer is not responsible for any radio or TV interference caused by unauthorized modification to this equipment. It is the responsibilities of the user to correct such interference.

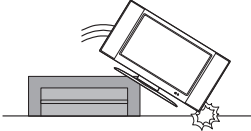
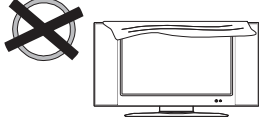
### **WARNING:**

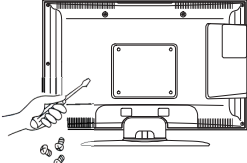
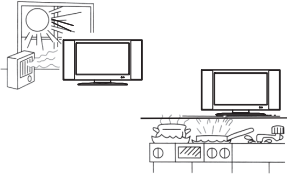
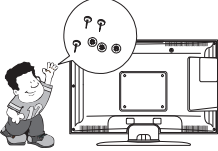
To prevent fire or shock hazard, do not expose the MFM to rain or moisture. Dangerously high voltages are present inside the MFM. Do not open the cabinet. Refer servicing to qualified personnel only.

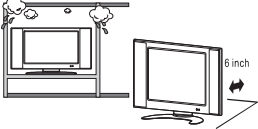
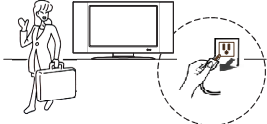
# PRECAUTIONS AND REMINDERS

<p>Place unit on even surfaces.</p> 	<p>Unplug immediately if other foreign materials are put inside MFM box or if the MFM fell down.</p> 	<p>Do not cover or block any vents and openings. Inadequate ventilation may shorten the life of the display unit and cause overheating.</p> 
<p>Unplug immediately if there is malfunction such as no picture, no video/audio, smoke and bad odor from MFM.</p> 	<p>Prohibit/Avoid opening MFM cabinet.</p> 	<p>Avoid direct sunlight, dusty, high humidity and smoky areas.</p> 
<p>Don't throw any object inside the MFM box like metals or other flammable materials.</p> 	<p>Remember to unplug the AC cord from the AC outlet before cleaning. Do not use liquid cleaners or aerosol cleaners to clean the display.</p> 	<p>Call service personnel to clean the internal part of the MFM once a year.</p> 
<p>Don't place the MFM in confined spaces or in a box when using it.</p> 	<p>Make sure to unplug the unit when not in use for a long period of time (days).</p> 	<p>Do not place the display near water, such as bathtub, washbasin, kitchen sink, laundry tub, swimming pool or in a damp basement.</p> 

## Notice for Remote Controller

<p>Avoid Dropping</p> 	<p>Avoid Liquids</p> 	<p>Avoid Aerosol Cleaners</p> 
---	--	---

# IMPORTANT SAFETY INSTRUCTIONS

## Read before operating equipment

1. Read these instructions.
2. Keep these instructions.
3. Heed all warnings.
4. Follow all instructions.
5. Do not use this apparatus near water.
6. Clean only with a dry cloth.
7. Do not block any of the ventilation openings. Install in accordance with the manufacturers instructions.
8. Do not install near any heat sources such as radiators, heat registers, stoves, or other apparatus (including amplifiers) that produce heat.
9. Do not defeat the safety purpose of the polarized or grounding type plug. A polarized plug has two blades with one wider than the other. A grounding type plug has two blades and third grounding prong. The wide blade or third prong is provided for your safety. When the provided plug does not fit into your outlet, consult an electrician for replacement of the obsolete outlet.
10. Protect the power cord from being walked on or pinched particularly at plugs, convenience receptacles, and the point where they exit from the apparatus.
11. Only use attachments/accessories specified by the manufacturer.
12. Use only with a cart, stand, tripod, bracket, or table specified by the manufacturer, or sold with the apparatus. When a cart is used, use caution when moving the cart/apparatus combination to avoid injury from tip-over.



13. The MFM should be operated only from the type of power source indicated on the label. If you are not sure of the type of power supplied to your home, consult your dealer or local power company.
14. Unplug this apparatus during lightning storms or when unused for long periods of time.
15. Refer all servicing to qualified service personnel. Servicing is required when the apparatus has been damaged in any way, such as power-supply cord or plug is damaged, liquid has been spilled or objects have fallen into apparatus, the apparatus has been exposed to rain or moisture, does not operate normally, or has been dropped.
16. The Class I apparatus shall be connected to a mains socket outlet with a protective earthing connection.
17. The mains plug or appliance coupler is used as the disconnect device, the disconnect device shall remain readily operable.
18. To reduce the risk of electric shock, do not perform any servicing other than that contained in the operating instructions unless you are qualified to do so.
19. For use only with a third party Listed Wall Mounting Bracket with minimum weight/load (see page 26).
20. Tilt/Stability – All televisions must comply with recommended international global safety standards for tilt and stability properties of its cabinets design.
  - Do not compromise these design standards by applying excessive pull force to the front, or top, of the cabinet, which could ultimately overturn the product.
  - Also, do not endanger yourself, or children, by placing electronic equipment/toys on the top of the cabinet. Such items could unsuspectingly fall from the top of the set and cause product damage and/or personal injury.

21. Wall or Ceiling Mounting – The appliance should be mounted to a wall or ceiling only as recommended by the manufacturer.
22. Power Lines – An outdoor antenna should be located away from power lines.
23. Outdoor Antenna Grounding – If an outside antenna is connected to the receiver, be sure the antenna system is grounded to provide some protection against voltage surges and built up static charges. Section 810 of the National Electric Code, ANSI/NFPA No. 70-1984, provides information with respect to proper grounding of the mats and supporting structure grounding of the lead-in wire to an antenna-discharge unit, size of grounding connectors, location of antenna discharge unit, connection to grounding electrodes and requirements for the grounding electrode. See Figure below.

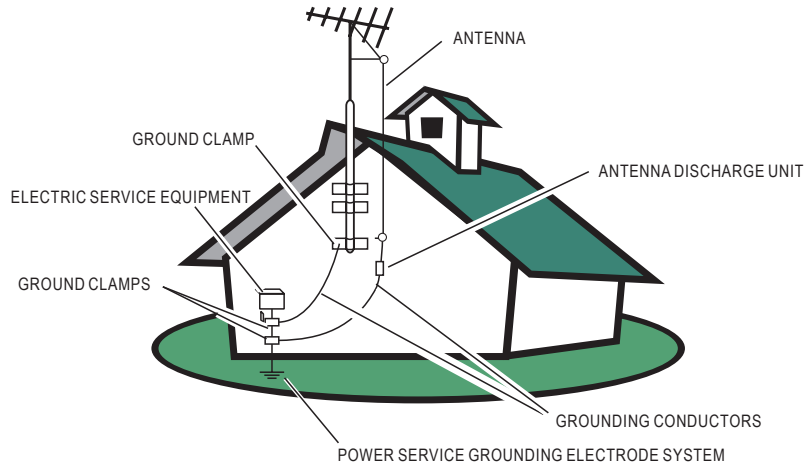

**EXAMPLE OF ANTENNA GROUNDING AS PER NATIONAL ELECTRICAL CODE** Note to the CATV system installer: This reminder is provided to call the CATV system installer's attention to Article 820-40 of the NEC that provides guidelines for proper grounding and, in particular, specifies that the cable ground shall be connected to the grounding system of the building, as close to the point of cable entry as practical. Please, make sure to connect the power plug to the wall outlet socket after connecting the MFM to the adapter!

24. Apparatus shall not be exposed to dripping or splashing and no objects filled with liquids, such as vases, shall be placed on the apparatus.
25. Excessive sound pressure from earphones and headphones can cause hearing loss. Adjustment of the equalizer to maximum increases the earphones and headphones output voltage and therefore the sound pressure level.

### △ CAUTION

These servicing instructions are for use by qualified service personnel only. To reduce the risks of electric shock do not perform any servicing other than that contained in the operating instructions unless you are qualified to do.





HDMI, the HDMI logo, and High-Definition Multimedia Interface are trademarks or registered trademarks of HDMI Licensing, LLC.

## **LCD panel**

The LCD panel used in this product is made of glass. Therefore, it can break when the product is dropped or impacted upon by other objects.

The LCD panel is a very high technology product, giving you finely detailed pictures. Occasionally, a few non-active pixels may appear on the screen as a fixed point of blue, green or red. This does not affect the performance of your product.

In order to ensure long performance of your set and reduce the risk of screen burning, please observe the following precautions.

- Do not display still images (still computer and video game images, logos, pictures, text and images displayed in 4:3) for extended periods of time.
- Use a screen saver when using a computer.

## **PACKAGE CONTENTS**

- Multifunction monitor (MFM) with Analogue (ATV) or Digital (DTV) operation, depending on regional requirements
- Remote Control
- Two (AAA) Batteries for the Remote Control
- Base
- Power Cord
- User Manual
- Quick Setup Guide
- Audio Line In Cable
- VGA Cable
- HDMI Cable
- Composite with RCA cable

## SETTING UP THE MFM

**IMPORTANT:** Do not apply pressure to the screen display area, which may compromise the integrity of the display. The manufacturer's warranty does not cover user abuse or improper installation.

### ATTACHING THE BASE

**IMPORTANT:** The Base of the MFM must be assembled prior to usage.

1. Place MFM unit face down on a soft and flat surface (blanket, foam, cloth, etc.) to prevent any damage to the MFM
2. Carefully align and insert the Base to the stand.
3. Gently push the Base towards the MFM until the locking mechanism locks into place.

#### ATV Interface

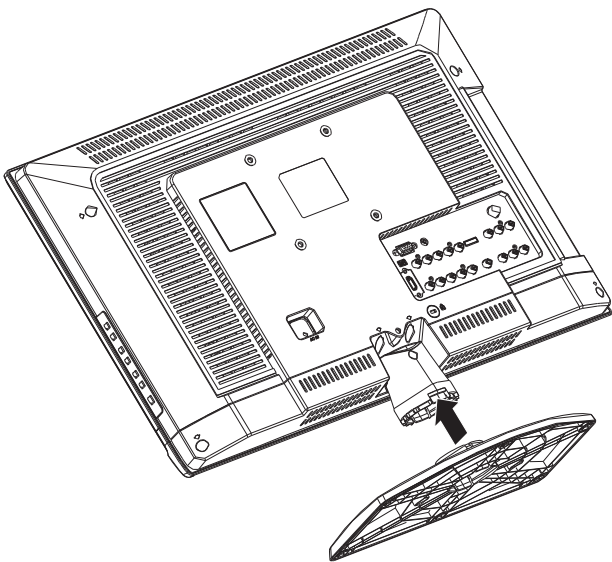

#### DTV Interface

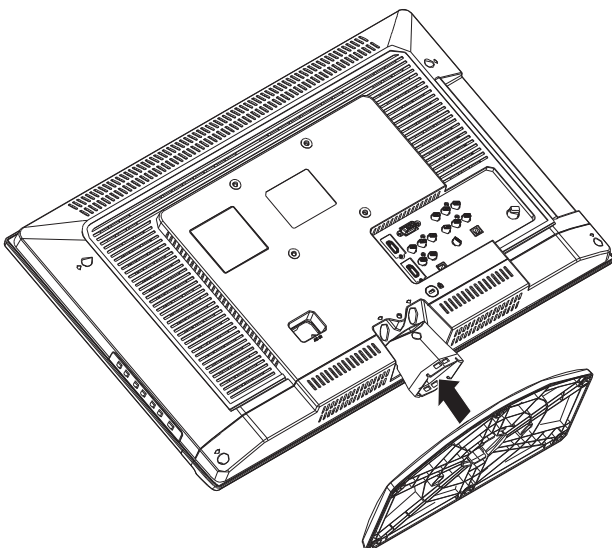

## PREPARING THE MFM FOR WALL MOUNTING

Place the MFM at least 2.36 inches (60 mm) from the wall to prevent cable interference.

Before mounting your MFM on the wall, you need to remove the base.

For your safety, please use listed wall mount bracket with minimum weight of the MFM without stand. (☞ page 26.)

To prepare the MFM to attach a wall mount bracket (sold separately):

1. Loosen the screws holding your MFM to the stand and remove the stand base from the MFM.
2. Secure the third party wall mount bracket to the back of your MFM using four screws, as indicated in the illustration.

#### ATV Interface

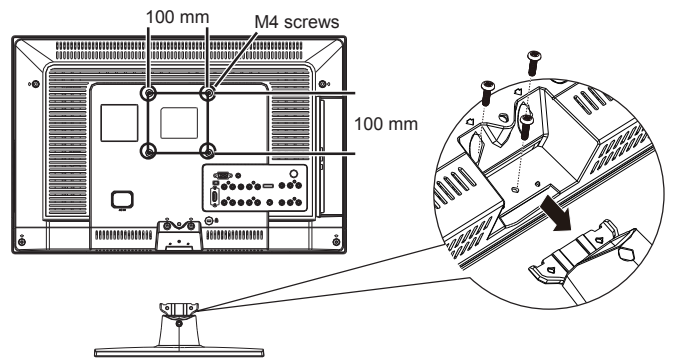

#### DTV Interface

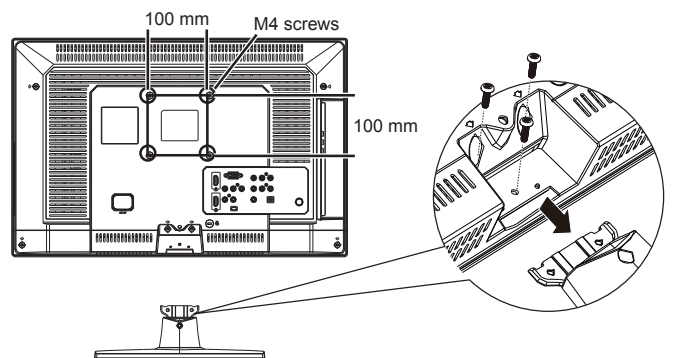

#### NOTE

- Wall mount bracket & screws are not included

## SELECTING A GOOD LOCATION

Please make sure to connect the power plug to the wall outlet socket after connecting the MFM to the power cord!

1. **Install the base stand; place the MFM on a solid surface.**

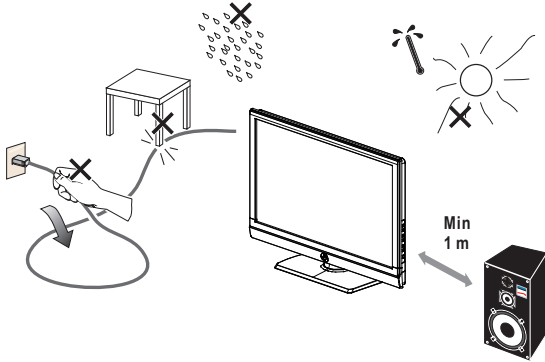

Ensure that the MFM is placed in a position to allow free flow of air. Do not cover the ventilation openings on the back cover.

To prevent any unsafe situations, flame sources, such as lighted candles, should not be placed on or in the vicinity.

Avoid heat, direct sunlight and exposure to rain or water. The equipment should not be exposed to dripping or splashing water.

2. Connect the antenna cable or CATV cable to the aerial socket **TV ANTENNA** at the back of the MFM.

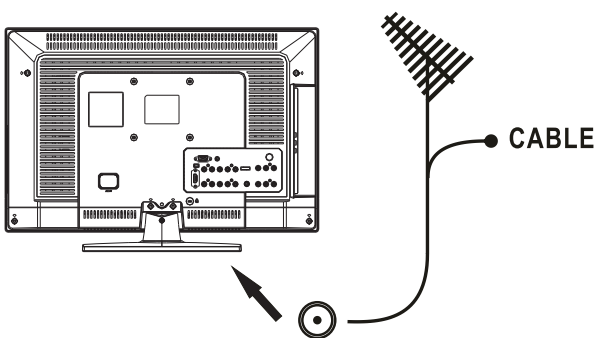

3. **Remote control:**

Remove the cover of the battery compartment. Insert the 2 batteries supplied (Type AAA 1.5V).

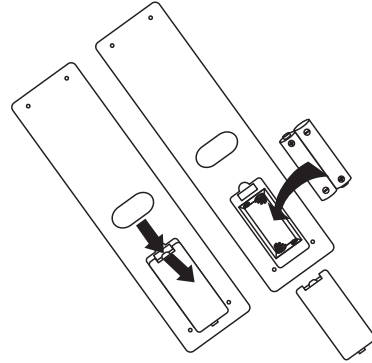

4. **Power:**

Insert the power cord in the wall socket with AC power supply. You can see LED states at the front panel. If the LED colour is Green, the MFM set power is on. If the LED colour is Red, the MFM set is in standby state.

5. **Turn on the MFM:**

Press the **POWER** key on the Remote control or the side panel control knobs on the monitor. The MFM will turn on in a minute with display on the screen.

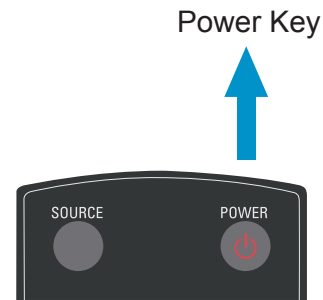

## INSTALLING THE MONITOR DRIVER

The CD that is included with the MFM contains the monitor driver that you can install on your computer.

### INSTALLING THE DRIVER

If you determine that you need to update the driver, you can install the monitor-driver INF and ICM files from the CD, or download them from the Internet.

To install the monitor -driver software from the CD:

1. Insert the CD in your computer CD drive. The CD menu appears.
2. Select the language.
3. Click **Install Monitor Driver Software**.
4. Follow the onscreen instructions.
5. Restart the computer.
6. Ensure that the proper resolutions and refresh rates appear in the Display Control Panel settings. Refer to the Windows® operating system documentation for more information.

#### **NOTE:**

- You might need to install the digitally signed monitor drivers (INF or ICM files) manually from the CD, in case of an installation error. Refer to the “Monitor Driver Software Readme” file on the CD for instructions (in English only).

## DOWNLOADING UPDATED DRIVERS FROM THE INTERNET

To download the latest version of drivers and software files from the HPSupport site:

1. Refer to: <http://www.hp.com/support>.
2. Select your country/region.
3. Select Download Drivers and Software.
4. Enter the model number of your monitor.
5. The software-download pages for your monitor are displayed.
6. Download and install the driver and software files by using the instructions in the download pages.
7. Ensure that your system meets the requirements.

# LOCATING THE MFM CONNECTORS AND CONTROLS

Before connecting any external equipment to the monitor, turn off all main power switches on the external equipment. If there is no switch, remove the main power plug from the wall socket.

Connect the power cord into the AC IN socket found at the back of the MFM.

## NOTE:

- Please use the power cord (included) with a grounded (earthed) pin and two flat current-carrying pins. Use only the power cord received with this monitor.

## ATV Connectors

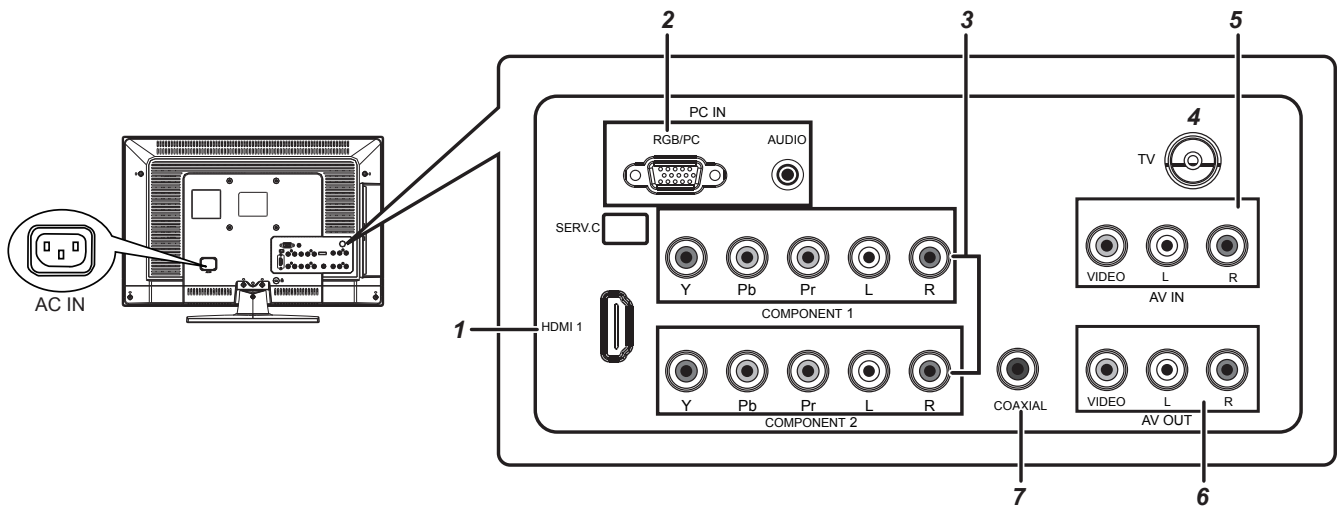

1. ⊕ **HDMI1 (input terminals)** — High-Definition Multimedia Interface input receives digital audio and uncompressed digital video from an HDMI device or uncompressed digital video from a DVI device ( ↗ page 16-17).
2. ⊕ **PC IN (VGA / Audio) input terminal** — For use when connecting a personal computer (PC) ( ↗ page 17).
3. ⊕ **Component (Video and L/R Audio) input terminal** — For use when connecting a high-definition component video device with standard audio output. ( ↗ page 14).
4. **TV (Antenna input terminal)** — Analogue TV antenna signal input ( ↗ page 8).
5. ⊕ **AV IN input terminals** — For use when connecting a composite video device.
6. ⊕ **AV output terminals** — For use when connecting a video recorder with standard video and standard audio input.
7. ⊕ **Digital Audio (coaxial) output terminals** — For use when connecting an amplifier with coaxial type digital audio input ( ↗ page 15).

## DTV Connectors

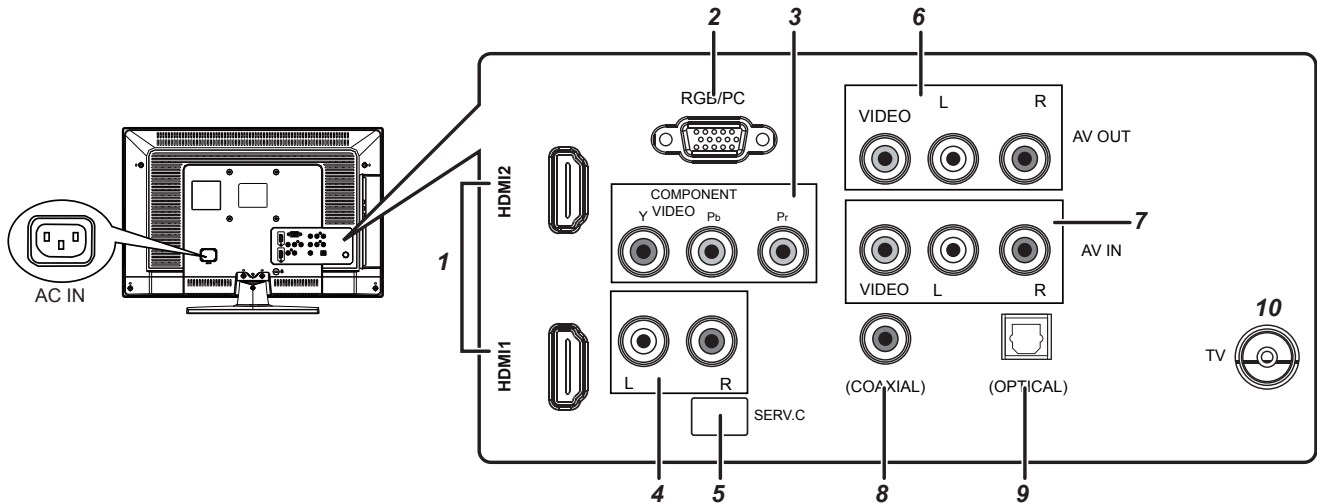

1. **HDMI1, 2 (input terminals)** — High-Definition Multimedia Interface input receives digital audio and uncompressed digital video from an HDMI device or uncompressed digital video from a DVI device ( [page 16-17](#)).
2. **PC input terminal** — For use when connecting a personal computer (PC) ( [page 17](#)).
3. **Component input terminal** — For use when connecting a high-definition component video device with standard audio output. ( [page 14](#)).
4. **Audio input terminal** — For use when PC, Component or DVI device with standard audio output.
5. **SERVICE** — Technician service use only.
6. **AV output terminals** — For use when connecting an ATV/DTV video recorder with standard video and standard audio input.
7. **Composite input terminals** — For use when connecting a composite video device.
8. **Digital Audio (coaxial) output terminals** — For use when connecting an amplifier with coaxial type digital audio input ( [page 15](#)).
9. **Digital Audio (optical) output terminals** — For use when connecting an amplifier with optical type digital audio input ( [page 15](#)).
10. **TV (Antenna input terminal)** — Analogue TV/Digital DVB-T antenna signal input ( [page 8](#)).

## FRONT PANEL CONTROLS

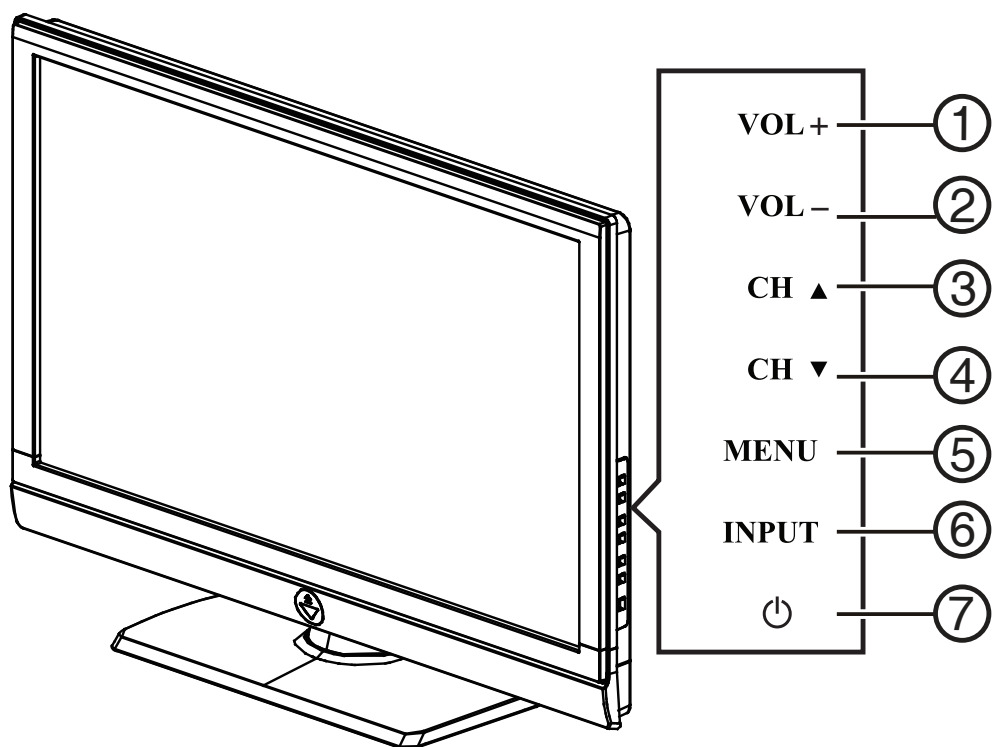

1	VOL +	<b>VOL +:</b> Press to increase the sound volume level.
2.	VOL -	<b>VOL - :</b> Press to decrease the sound volume level.
3.	CH ▲	<b>CH ▲:</b> Press to select the next higher Programme number.
4.	CH ▼	<b>CH ▼:</b> Press to select the next lower Programme number.
5.	MENU	<b>Menu Button:</b> Press to open or exit the OSD (on-screen display) menu.
6.	INPUT	<b>Input Button:</b> Press to select the input source.
7.	 POWER	<b>Power Button:</b> Press to turn on/off (standby) the MFM set. (Press to turn on the MFM after the power on status, LED changes to the Green colour and stops flashing.)

# USING THE REMOTE CONTROL

## POWER

Press to turn ON/OFF (standby) the MFM.

## SOURCE

Press repeatedly to choose the various input sources.

Number buttons

Press to enter TV channel number to select channel.

## EPG

Press to display the Electronic Programme Guide.

## PRE CH

Press to display the previous channel.

## HDMI

Press to choose HDMI source mode.

## VIDEO

Press to choose CV1, CV2, AV IN, AV2, or SVIDEO source mode.

## TV

Press to choose TV source mode.

## PC

Press to choose PC source mode.

## VOL+ / VOL-

Press + or - to adjust the volume.

## CH ^ / CH v

Press ^ or v to browse through the TV channels.

## MUTE

Switch the sound ON/OFF.

## ZOOM

Select the display aspect from Auto, Normal (4:3), Wide (16:9), subtitle, full screen, or 14:9 mode.



## DUAL

Press to select from mono, stereo, or TV channel.

## SOUND

Press to choose from Personal, Standard, News, or Movie.

## PICTURE

Press to choose the Smart Picture mode from Personal, Vivid, Standard, Movie, Game, or Eco.

## SLEEP

Press to set the preset time to switch the MFM to standby mode automatically.

## MENU/EXIT

Press to open or close menu.

## ▲, ▼, ◀, ▶, OK

Press to adjust or confirm the various function items on the menu.

## INFO

Press to display or close the information screen.

## Colour buttons

- In TV mode: Follow the directions in the OSD screen.
- In Text mode: Text control buttons.



**TELETEXT**

Press to display or close the Teletext.

**MIX**

Display the Teletext with TV.

**SIZE**

Press to change the font size: Full screen, Top half and Bottom half.

**SUBPAGE**

Display the sub page (when available).

**INDEX**

Press to return to page 100 or the index page.

**SUBTITLE**

- In TV mode: It works only for turning on the subtitle and change to the next page marked as subtitle.
- In Text mode: Select the next page marked as a subtitle page and request it as the display page.

**HOLD**

Press to stop the scrolling of pages. The text decoder stops receiving data.

**REVEAL**

Reveal hidden information such as answers to a quiz.

**FAV**

Display the Favourite Channel List.

**CH-LIST**

Display the Channel List.

**AD (Audio Description)**

No function.

**FREEZE**

Press to freeze the TV picture.

## VIEWING MODE ILLUSTRATIONS

### Normal Mode

The original content would be at the centre of the screen.

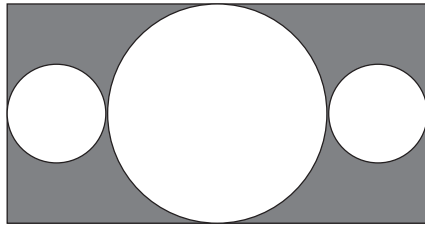

16:9 Content

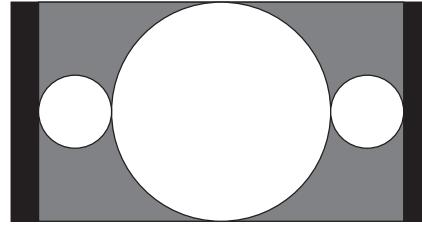

4:3 Content

### Wide Mode

The original content in this mode has to fill the entire screen of the display.

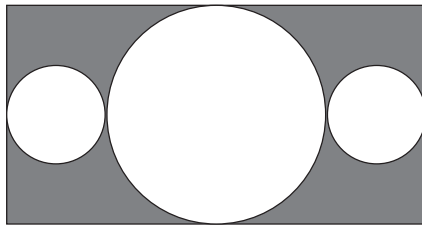

16:9 Content

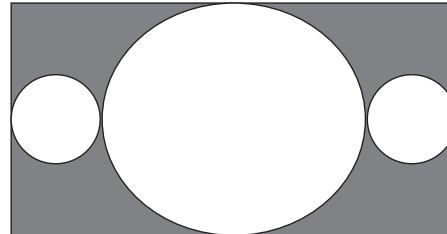

4:3 Content

### ZOOM Mode

For those wide format images which are originally programmed into 4:3 frames with black bars around, this mode would stretch the image in both width and height for full display with active data.

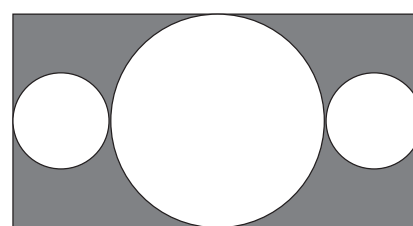
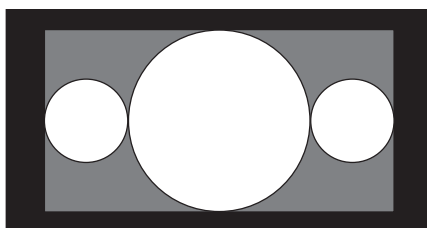

Same image in ZOOM mode

# CONNECTING TO THE MFM

## BACK CONNECTIONS

### ATV Connection example

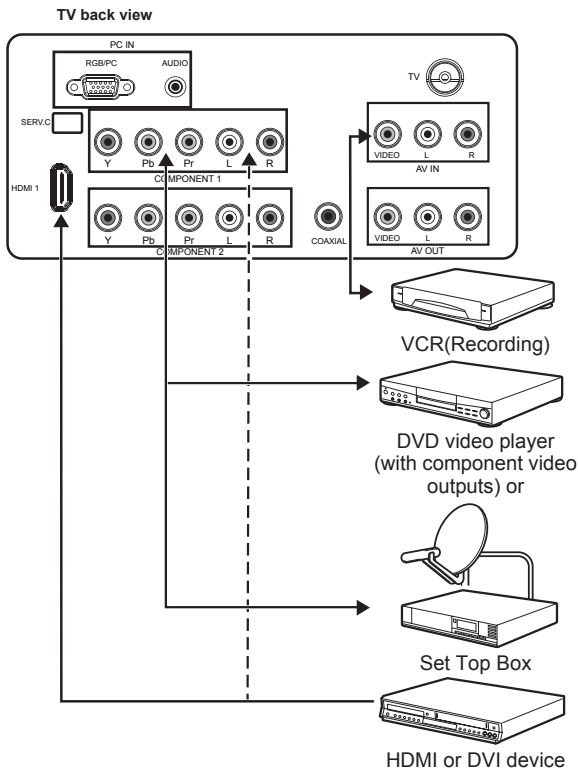

### DTV Connection example

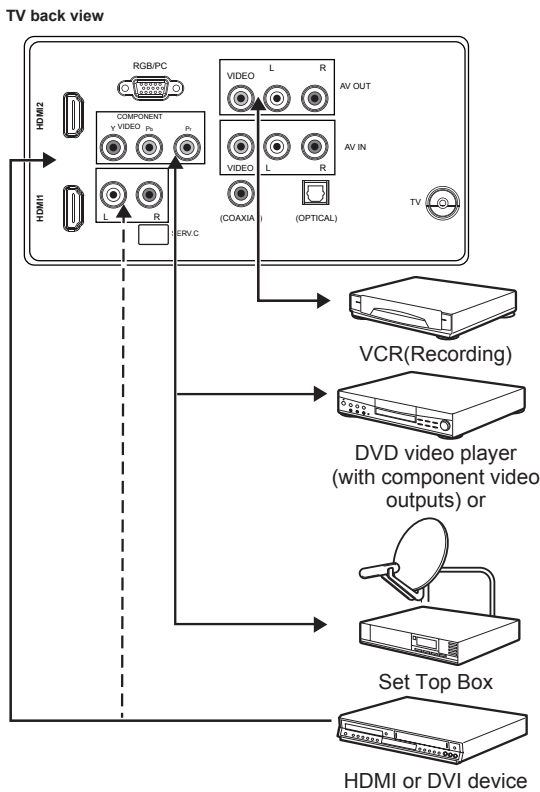

- Before connecting any external equipment, turn off all main power switches. If there is no switch, remove the main power plug from the wall socket.

- The unauthorized recording of television programmes, DVDs, video tapes and other materials may infringe upon the provisions of copyright law.
- The **COMPONENT VIDEO INPUT** consists of three component video signals (**Y, P<sub>b</sub>, P<sub>r</sub>**) and provides the best picture performance. These terminals can only be used with component video compatible equipment such as a DVD video player.
- Additional equipment and cables shown are not supplied with this monitor.
- **TV OUTPUT**  
Supports only ATV/DTV signal to display out or by VCR TV signal recording use.

### Connecting an audio system

You can enjoy high quality dynamic sound by connecting the monitor to an audio system.

#### ⚠ CAUTION:

- DO NOT connect the **DIGITAL AUDIO** output terminal to the AC-3 RF input of a Dolby Digital Receiver with a built-in Dolby Digital decoder.
- Connect the **DIGITAL AUDIO** output terminal to the **Coaxial** input of a Receiver or Processor.
- Refer to the owner's manual of the connected equipment as well.
- When you connect the monitor to other equipment, be sure to turn off the power and unplug all of the equipment from the wall outlet before making any connections.
- The output sound of the monitor has a wide dynamic range. Be sure to adjust the audio amplifier's volume to a moderate listening level before turning on the power. Otherwise, the speakers and your hearing may be damaged by a sudden high volume sound.
- Turn off the amplifier before you connect or disconnect the monitor's power cord. If you leave the amplifier power on, the speakers may be damaged.

#### ⚠ Warning:

When you are connecting (via the **DIGITAL AUDIO** output terminal) an AV decoder that does not have Dolby Digital or MPEG decoding function, be sure to set **PCM** in **SPDIF Type** under **SOUND** menu. Otherwise, the speakers and your hearing may be damaged by a sudden high volume sound.

## Connecting an amplifier equipped with a Dolby Digital decoder

### ATV Connection

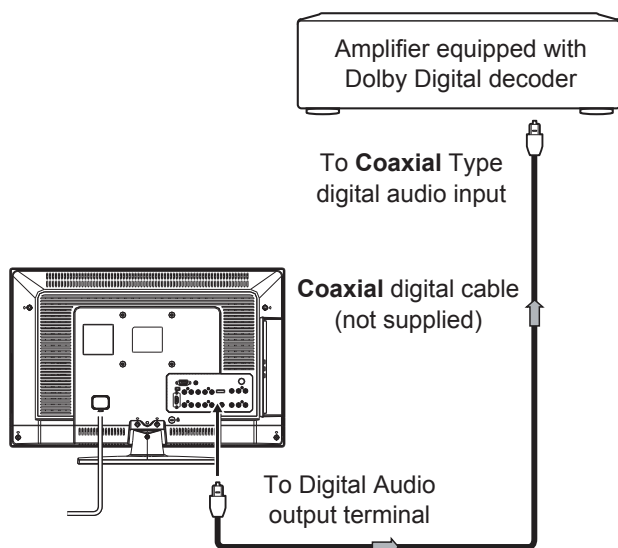

### DTV Connection

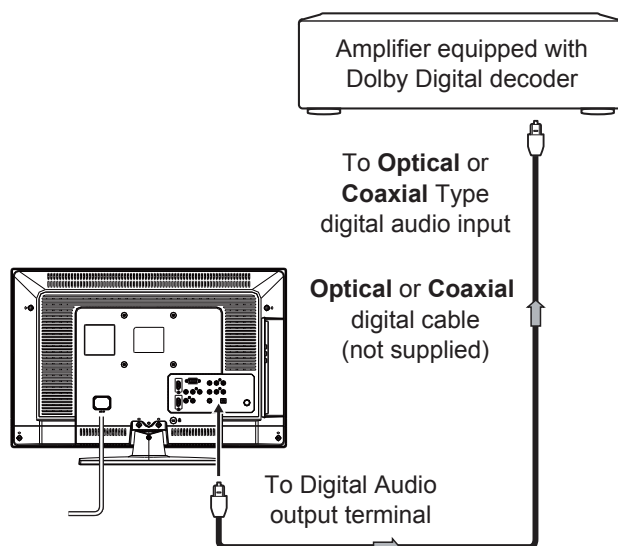

You can enjoy dynamic realistic sound by connecting the monitor to an amplifier equipped with a Dolby Digital decoder or Dolby Digital processor. When using this setup, select **Dolby Digital** in Audio Mode.

## Connecting an amplifier equipped with an MPEG decoder

### ATV Connection

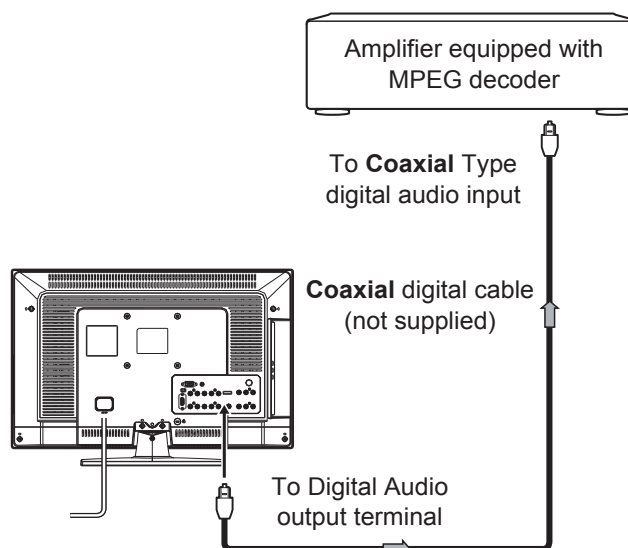

### DTV Connection

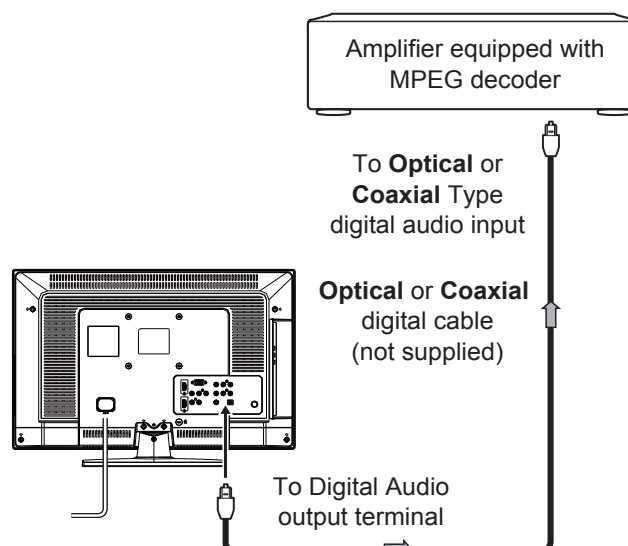

You can enjoy motion picture with dynamic realistic sound by connecting the monitor to an amplifier equipped with an MPEG audio decoder or MPEG audio processor. When using this setup, select **MPEG** in Audio Mode.

## Connecting an amplifier equipped with a digital audio (optical or coaxial) input

### ATV Connection

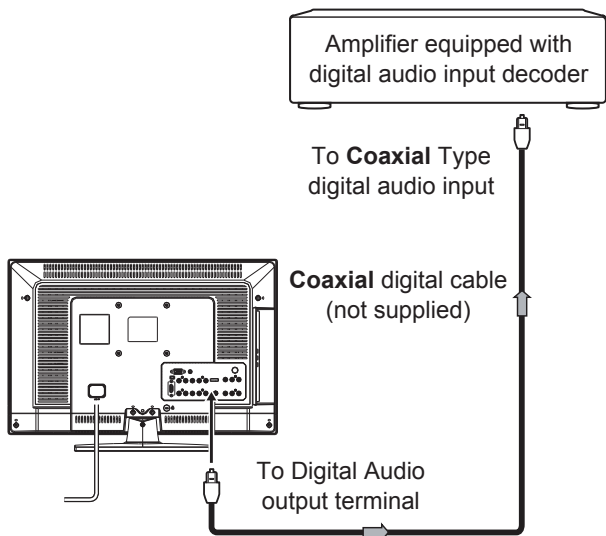

### DTV Connection

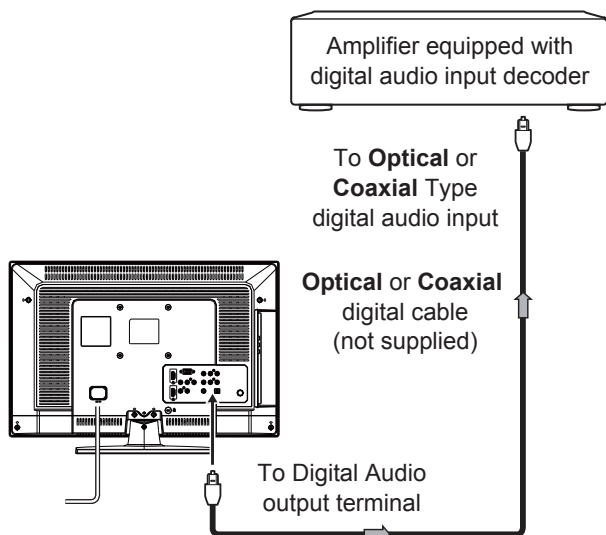

You can enjoy dynamic sound of 2-channel digital stereo by connecting the monitor to an amplifier equipped with a digital audio (optical or coaxial) input and speaker system (right and left front speakers). When using this setup, select **PCM** in SPDIF Type under SOUND menu.

## SIDE CONNECTIONS

### ATV Connection example

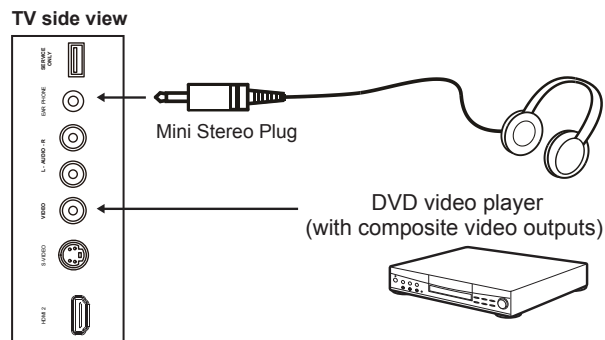

### DTV Connection example

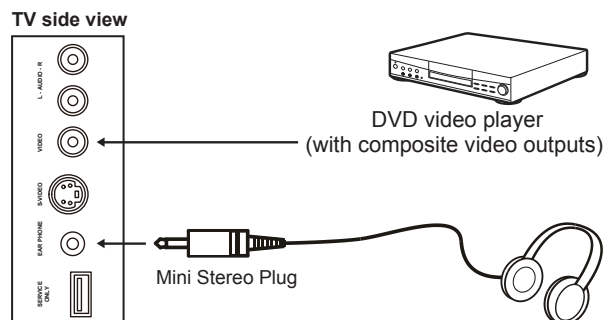

- The audio from the speaker will be muted when connecting the headphone to this terminal.
- The service port is for service only.

## CONNECTING AN HDMI OR A DVI DEVICE

### NOTE:

- When turning on your electronic components, turn on the MFM first, and then the HDMI or DVI device.
- When turning off your electronic components, turn off the HDMI or DVI device first, and then the MFM.
- This MFM may not be compatible with features and/or specifications that may be added in the future.
- Some early HDMI equipment may not work properly with your latest HDMI MFM, due to the adoption of a new standard.
- This MFM is only operable with L-PCM on 32/44.1/48 kHz and 16/20/24 bits.

The HDMI input on your MFM receives digital audio and uncompressed digital video from an HDMI device or uncompressed digital video from a DVI device.

This input is designed to accept HDCP programme material in digital from EIA/CEA-861/861B compliant consumer electronic devices (such as a set top box or DVD player with HDMI or DVI output).

**For acceptable video signal formats** (see page 25).

The HDMI input is designed for best performance with 1080i high-definition video signals, but will also accept and display VGA, SVGA, XGA, WXGA, SXGA, 480i, 480p, 576i, 576p, 720p, 1080i, and 1080p signals.

- **HDMI:** High-Definition Multimedia Interface
- **DVI:** Digital Video Interface
- **HDCP:** High-bandwidth Digital Content Protection
- EIA/CEA-861/861B compliance covers the transmission of uncompressed digital video with high-bandwidth digital content protection, which is being standardized for reception of high-definition video signals. Because this is an evolving technology, it is possible that some devices may not operate properly with the MFM.
- **E-EDID:** Enhanced-Extended Display Identification
- **L-PCM:** Linear-Pulse Code Modulation

## CONNECTING AN HDMI DEVICE

### One HDMI cable (type A connector)

#### ATV Connection

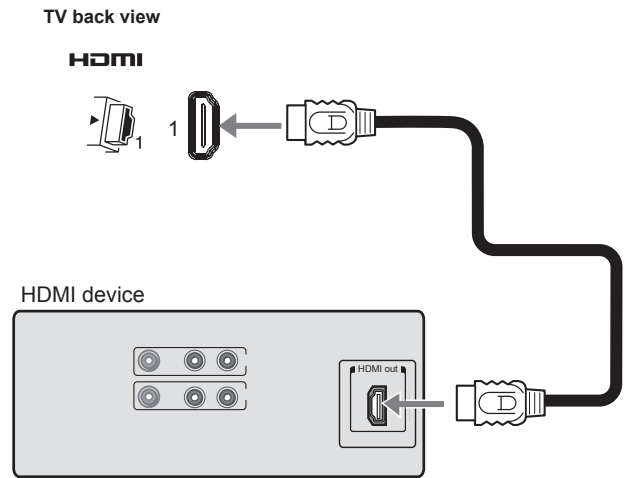

#### DTV Connection

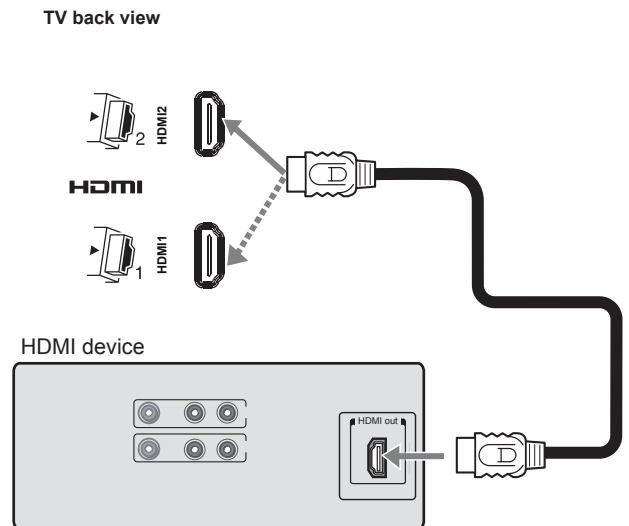

For proper operation, it is recommended that you use a short HDMI cable with the HDMI Logo (HDMI).

**HDMI** cable transfers both video and audio.

### NOTE:

- It is possible that some HDMI device may not operate properly with this MFM.

## CONNECTING A DVI DEVICE

### One HDMI (type A connector)-to-DVI adapter cable (not provided with MFM) and audio cables

#### ATV Connection

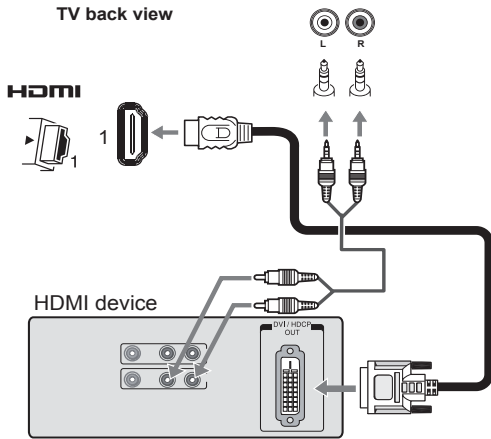

#### DTV Connection

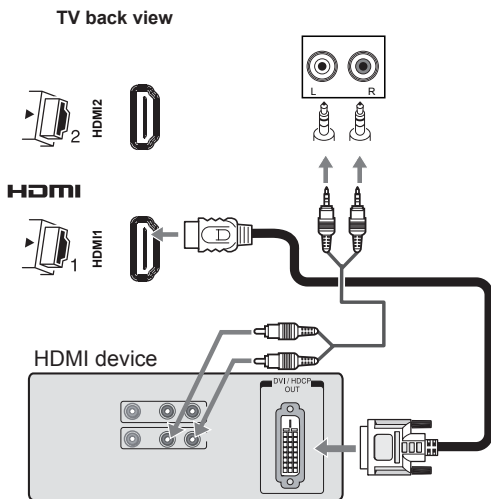

### HDMI (type A connector)-to-DVI adapter cable (not provided with MFM)

For proper operation, the length of an HDMI-to-DVI adapter cable should not exceed 3m. The recommended length is 2m.

### Standard analogue audio cables

An HDMI-to-DVI adapter cable (not provided with MFM) transfers only video. Separate analogue audio cables are required.

When connecting a DVI device, please connect to the HDMI 1 port only.

#### NOTE:

- HDMI, the HDMI logo, and High-Definition Multimedia Interface are trademarks or registered trademarks of HDMI Licensing, LLC.

## CONNECTING A COMPUTER

An analogue RGB (15 pin) computer cable can be connected.

#### ATV Connection

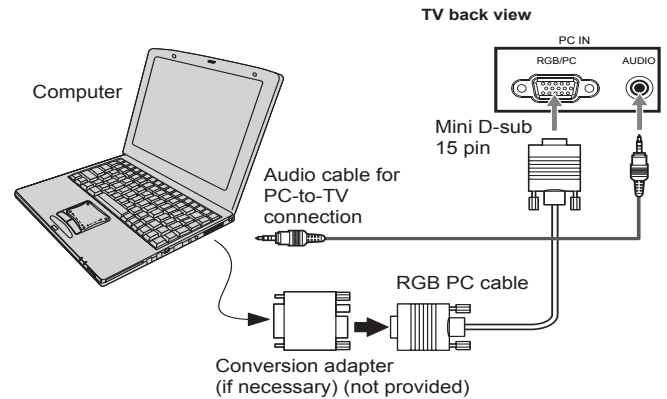

#### DTV Connection

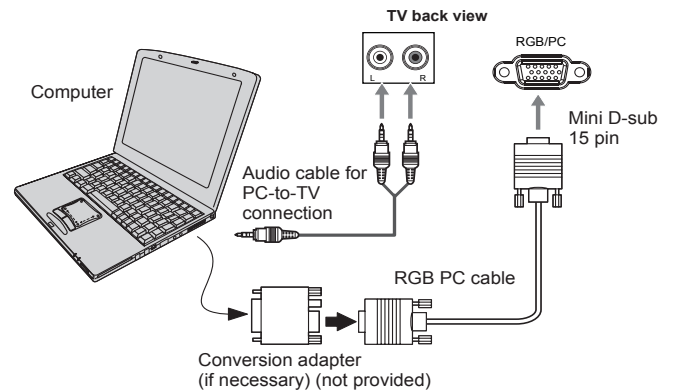

Connect a PC cable from the computer to the  $\oplus$  RGB/PC terminal on the back of the MFM.

**For acceptable PC signal formats** (page 25).

However, these signal formats are converted to match the number of pixels of the LCD panel.

Therefore, the MFM may not display small text properly.

If you connect this unit to your PC, the compressed image is displayed in S-XGA mode, therefore the picture quality may deteriorate and characters may not be read.

#### NOTE:

- Some PC models cannot be connected to this MFM.
- There is no need to use an adapter for computers with DOS/V compatible mini D-sub 15 pin terminal.

- A bar may appear in the upper, lower, right or left side of the screen, or parts of the picture may be obscured depending on some signals. This is not the malfunction.
- If the edges of the picture are stretched, readjust the picture position adjustments in the PC of PICTURE menu.
- Depending on the specification of the PC you are playing the DVD-Video on, and the DVD's title, some scenes may be skipped, or you may not be able to pause during multi-angle scenes.

## SELECTING THE INPUT SOURCE

- First press **SOURCE** on the remote control to display the video input source list, then press **▲** or **▼** and **OK** in order to select the PC input mode (▶ page 25).
- This function may not be available for some signal or if no signal is received.
- The optimum points of the clock phase and sampling clock adjustments may be incomprehensible according to the input signals.

### Adjusting the picture settings

1. Press **MENU/EXIT** and use **◀** or **▶** to select **PICTURE**.
2. Use **▲** and **▼** to select **PC** and press **▶** or **OK**.
3. Use **▲** or **▼** to select an option and press **◀** or **▶** to adjust the setting as required.

### Using the Auto Adjust

Adjust Horizontal Position, Vertical Position, Horizontal Clock, and Clock Phase automatically. Depending on the type of signal, there is a possibility that the display may not be adjusted in its optimum condition with this function. In that case, please adjust each item manually.

1. Press **MENU/EXIT** and use **▲** and **▼** to select **Features**.
2. Use **▶** and **▼** to select **Auto Adjust** and press **▶** or **OK**.
3. Use **▶** or **OK** to highlight **Yes** and press **OK**.

## USING THE OSD MENUS

### FOR ATV MODEL

1. Press the **MENU/EXIT** button to display or close the main menu.
2. Use the **Navigation Ring** to move around to select, adjust or confirm an item in the OSD (On Screen Display) menu.

Press the **MENU/EXIT** button to enter the main OSD. Adjust the items including **Picture**, **Sound**, **Features**, and **Installation**. However, some function items in the menus may only be enabled in the particular source modes.

### • PICTURE MENU

#### Use Smart Picture

1. Press **VIDEO**.  
↳ The **Smart picture** menu appears.
2. Press **▲** **▼** to select one of the following smart picture settings.
  - Personal
  - Vivid
  - Standard
  - Movie
  - Game
  - Eco
3. Press **OK** to confirm the choice.  
The selected smart picture setting is applied.

#### Adjust Picture Setting

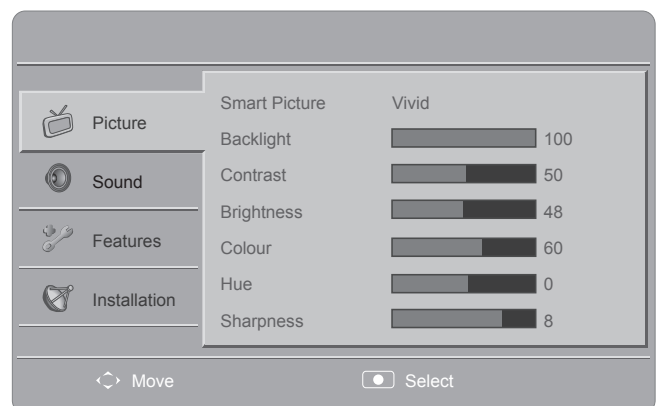

1. Press **MENU**.
2. Press **OK** to select **Picture**.  
↳ The **Picture** menu appears.



3. Press ▲ ▼ ◀ ▶ to select one of the following picture settings.

- **Smart picture:** Accesses pre-defined smart picture settings.
- **Backlight:** Adjusts the backlight brighter or darker.
- **Contrast:** Changes the level of bright parts in the picture keeping the dark parts unchanged.
- **Brightness:** Changes the level of light in the picture.
- **Colour:** Changes the level of saturation.
- **Hue:** Compensates colour variations in NTSC encoded transmissions.
- **Sharpness:** Changes the level of sharpness of fine details.
- **Noise reduction:** Filters and reduces the noise in the picture.
- **Colour temperature:** Sets the colour temperature to Cool (bluer), Normal (balanced), Warm (redder).
- **Adv. picture:** Digitally adjusts picture quality to optimal contrast, colour and sharpness.
  - **Dynamic contrast:** Automatically enhances contrast in an image. **Medium** setting is recommended.
  - **Dynamic backlight:** Adjusts the brightness of the TV backlight to match lighting conditions.
  - **MPEG artifact re.:** Smooths out transitions on digital pictures. You can switch this feature on or off.
  - **Colour enhancement:** Makes colours more vivid and improves the resolution of details in bright colours. You can switch this feature on or off.
- **PC mode:** Adjusts the picture when a PC is connected to the TV via HDMI/DVI.
- **Picture format:** Changes the picture format.
- **Horizontal shift:** Adjusts the picture horizontally for PC-VGA or YPbPr.
- **Vertical shift:** Adjusts the picture vertically for PC-VGA or YPbPr.

## • SOUND MENU

### Use smart sound

Use smart sound to apply pre-defined sound settings.

1. Press **SOUND**.
  - ↳ The **Smart sound** menu appears.
2. Press ▲ ▼ to select one of the following smart sound settings.
  - **Standard:** Adjusts sound settings to suit standard environments and types of audio.
  - **News:** Adjusts sound settings to ideally suit spoken audio, such as the news.
  - **Movie:** Adjusts sound settings to ideally suit movies.
  - **Personal:** Applies the settings that were customised in the sound settings.
3. Press **OK** to confirm your choice. The selected smart sound setting is applied.

### Adjust sound settings

1. Press **MENU**.
2. Press ▲ ▼ ◀ ▶ to select **Sound**.
  - ↳ The **Sound** menu appears.

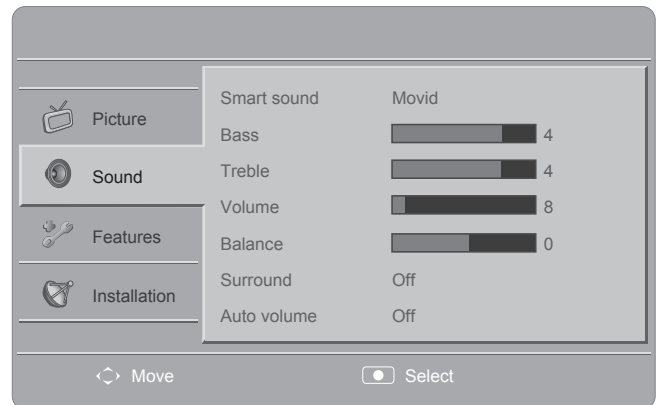

3. Press ▲ ▼ ◀ ▶ to select one of the following sound settings.
  - **Smart sound:** Accesses pre-defined smart sound settings.
  - **Bass:** Adjusts the bass value to fit your best.
  - **Treble:** Adjusts the treble value to fit your best listening.
  - **Volume:** Adjusts the volume.
  - **Balance:** Sets the balance of the left and right speakers to best fit your listening.
  - **Dual I-II:** Selects between audio languages if dual sound is broadcast.
  - **Mono/Stereo:** Selects between mono or stereo if stereo is broadcast.
  - **Surround:** Enables spatial sound.
  - **Auto volume:** Automatically reduces sudden volume changes, for example, when switching channels. When enabled, this produces a more consistent audio volume.
  - **Delta volume:** Levels out volume differences between channels or connected devices. Switch to the connected device before you change the delta volume.

## • FEATURES MENU

### Set the TV clock

You can display a clock on the TV screen.

1. Press **MENU**.
2. Select **Features ▶ Clock**.  
↳ The **Clock** menu appears.
3. Press ▲ ▼ ◀ ▶ or **Numeric buttons** to enter time.
4. Press **Done to confirm**.
5. Press **MENU to exit**.

### User timers

You can set timers to switch the TV on or switch to standby at a specified time.

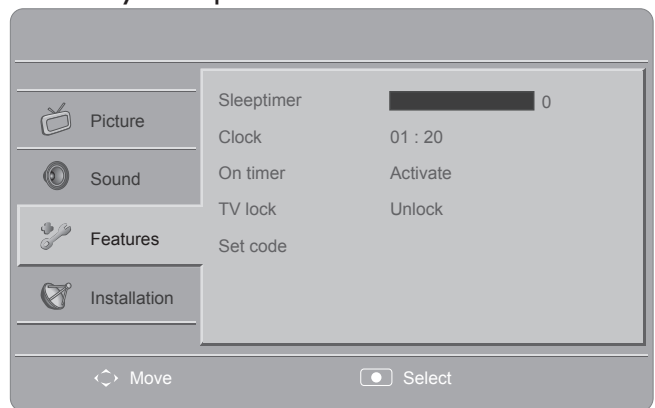

### Automatically switch the TV to standby (Sleeptimer)

Sleeptimer switches the TV to standby after a defined period of time.

1. Press **MENU**.
2. Select **Feature ▶ Sleeptimer**.  
↳ The **Sleeptimer** menu appears.
3. Press ◀ ▶ to set the sleep time.  
The Sleeptimer can be up to 180 minutes in steps of five minutes. If set to zero minutes, the Sleeptimer is switched off.
4. Press **OK** to activate the Sleeptimer.  
The TV switches to standby after the pre-defined period of time.

### NOTE

- You can always switch off your TV earlier or reset Sleeptimer during the countdown.
- When you press any button on the remote control with less than one minute left in the countdown, Sleeptimer will be automatically canceled.

## Automatically switch the TV on (On timer)

On timer switches the TV to a specified channel at a specified time from standby.

1. Press **MENU**.
2. Select **Features ▶ On timer**.
3. Press **▶** to enter the **On timer** menu.
4. Press **▲ ▼ ◀ ▶** to select **Activate** and set a frequency Daily, Once, or Off .
5. Press **OK** to confirm.
6. Press **▲ ▼ ◀ ▶** to select Time and set the starting time.
7. Press **Done** to confirm.
8. Press **▲ ▼ ◀ ▶** to select **Programme no.** and external source to set the channel.
9. Press **OK** to confirm.
10. Press **MENU** to exit.

### NOTE

- Select **On timer ▶ Activate ▶ Off** to disable **On timer**.
- When **On timer** is **Off**, only **Activate** can be selected.
- Set the **TV clock** before activating **On timer** feature.

## Use TV Lock

You can prevent your children from watching certain programmes or certain channels by locking the TV controls.

### Set / change code

1. Press **MENU**.
2. Press **▲ ▼ ◀ ▶** to select **Features ▶ Set code**.
3. Press **▶** to enter the **code** setup.
4. Enter your code using the **Numeric buttons**.
5. Re-enter the same code in the new dialogue box for confirmation.  
If the code is set successfully, the dialogue box will disappear. However, if the code cannot be set, a new dialogue box will prompt you to re-enter the code.
6. If you want to change the code, select **Features ▶ Change code**.

7. Enter your current code using the **Numeric buttons**.

If the code is validated, a new dialogue box will prompt you to enter your new code.

8. Enter the new code using the **Numeric buttons**.

A message appears prompting you to enter the new code again for confirmation.

### NOTE

- If you forget your code, enter '8888' to override any existing codes.

### Lock or unlock all channels and connected devices.

1. Press **MENU**.
2. Press **▲ ▼ ◀ ▶** to select **Features ▶ TV lock**.
3. Press **▶** to enter the **TV Lock**.  
↳ A screen appears prompting you to enter a code.
4. Enter your code using **Numeric buttons**.
5. Press **▲ ▼** to select **Lock** or **Unlock**.
6. Press **OK**.  
All channels and connected devices are locked or unlocked.
7. Press **MENU** to exit.

### NOTE

- If you select **Lock**, you have to enter your code every time you turn on your TV.
- Once you set the code, step 3 and 4 won't appear before turn off the TV.

### Lock or unlock one or more channels

1. When watching TV, press **CH LIST** to display the channel list.
2. Press **▲ ▼ ◀ ▶** to select a channel to lock or unlock.
3. Press **▶**.
4. Press **▲ ▼** select **Lock channel/Unlock channel**.
5. For each selection, press **OK** to lock or unlock the channel.

## • INSTALLATION

### Install channels

The first time you set up your TV, you are prompted to select a menu language and to install TV.

This chapter provides instructions on how to reinstall and fine tune channels.

### Automatically install channels

This section describes how to search and store channels automatically.

#### Step 1 Select your menu language

##### NOTE

- Skip this step if your language settings are correct.
1. Press **MENU**.
  2. Select **Installation ► Menu language**.
  3. Press **▲ ▼** to select a language setting.

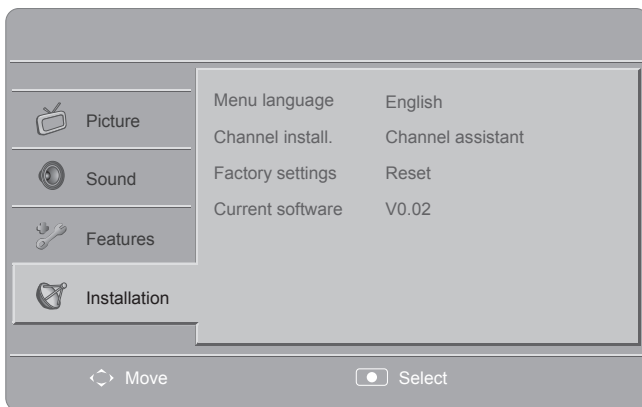

4. Press **OK** to confirm.
5. Press **MENU** to exit.

#### Step 2 Install Channels

Select your country for proper channel installation.

1. Press **MENU**.
2. Select **Installation ► Channel install ► Channel assistant**.

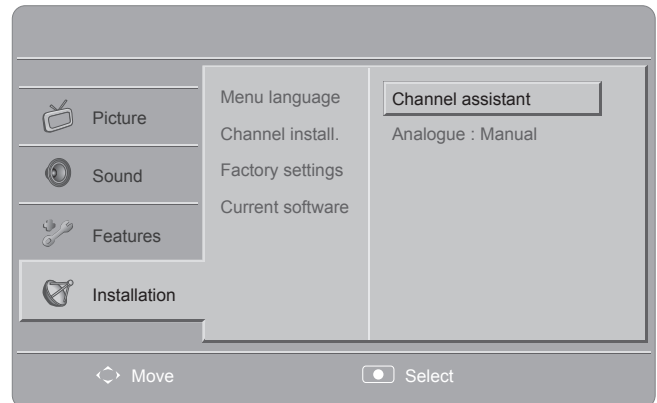

3. Press **◀ ▶** to select **Start** or **Cancel**.
4. Press **OK** to confirm your choice.
5. Press **▶** to next step.
6. Select **Start** and press **OK** to re-install channels.

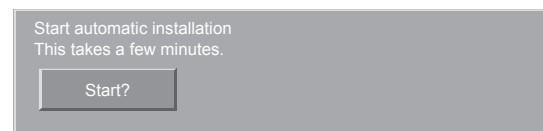

7. If you want to stop searching, select **Stop** and press **OK**.  
↳ A dialogue box appears asking you if you really want to **Stop** or **Continue** with the process.
8. Press **◀ ▶** to select **Stop** or **Continue**.
9. Press **OK** to confirm your choice.
10. When done, press **MENU** to exit.

## Manually install channels

This section describes how to search and store analogue TV channels manually.

1. Press **MENU**.
2. Select **Installation ► Channel install ► Analogue: Manual**.  
↳ The **Analogue: Manual** menu appears.
3. Press **▲ ▼** to select the item you want to adjust.
  - Colour system
  - Sound system
  - Search
  - Fine-tune
  - Store cur. chan.
  - Store new channel
  - Skip channel

### Step 1 Select your system

#### NOTE

- Skip this step if your system settings are correct.
1. Press **MENU**.
  2. Select **Installation ► Channel install ► Analogue: Manual**.  
↳ The **Analogue: Manual** menu appears.
  3. Press **▲ ▼ ◀ ▶** to select and enter **System**.
  4. Press **▲ ▼** to select your country or region.
  5. Press **OK** to confirm.
  6. Press **MENU** to exit.

### Step 2 Search and store new TV channels

1. Press **MENU**.
2. Select **Installation ► Channel install ► Analogue: Manual**.  
↳ The **Analogue: Manual** menu appears.
3. Press **▲ ▼ ◀ ▶** to select and enter **Search**.
4. Press **▲ ▼** or use **Numeric buttons** to manually enter the three digit frequency.
5. Press **OK** to begin search.
6. Press **◀** when the new channel is found.
7. Press **▲ ▼** to select **Store new channel** under a new channel number.
8. Press **▶** to enter **Store new channel**.

9. Press **◀ ▶** to select **Yes** and press **OK** to store the new channel.
10. Press **MENU** to exit.

### Fine tune analogue channels

You can manually fine tune analogue channels when reception is poor.

1. Press **MENU**.
2. Select **Installation ► Channel install ► Analogue: Manual**.  
↳ The **Analogue: Manual** menu appears.
3. Press **▲ ▼ ◀ ▶** to select and enter **Fine-tune**.
4. Press **▲ ▼** to adjust frequency.
5. Press **OK** when done.
6. Press **▲ ▼** to select **Store cur. chan.** to store channel number.
7. Press **▶** to enter **Store cur.chan..**
8. Press **◀ ▶** to select **Yes** and press **OK** to store the current channel.
9. Press **MENU** to exit.

### Skip channels

1. Press **MENU**.
2. Select **Installation ► Channel install ► Analogue: Manual**.  
↳ The **Analogue: Manual** menu appears.
3. Press **▲ ▼** to select and enter **Skip channel**.
4. Press **◀ ▶** to select **Yes** and press **OK** to skip the channel you are currently watching.  
↳ The selected channel is skipped when you press **CH ^ / v** on your remote control or view the channel list.
5. Press **MENU** to exit.

#### NOTE

- You can restore a skipped channel to your channel listing (see 'Step 2 Search and store new TV channels').

## Rename channels

Channels can be renamed so that a name of your choice appears whenever the channel is selected.

1. When watching TV, press **CH LIST** to display the channel list.
2. Select the channel you want to rename.
3. Press **►**.  
↳ The channel options menu appears.
4. Press **▲ ▼ ◀ ▶** to select and enter **Rename chan..**  
↳ A text input box appears.
5. Press **▲ ▼ ◀ ▶** to select characters.
6. Press **OK** to confirm each of the characters.

### NOTE

- Rename channels- the length of the name is limited to six characters.
- Use **Aa** to change upper-case letter to lower-case letter and vice versa.

## Rearrange channels

After you install channels, you can rearrange the order in which they appear.

1. When watching TV, press **CH LIST** to display the channel list.
2. Press **►**.  
↳ The channel options menu appears.
3. Press **▲ ▼ ◀ ▶** to select and enter **Reorder.**
4. Press **▲ ▼ ◀ ▶** to select the new position.
5. Press **OK** to confirm the new position.
6. Press **►**.  
↳ **Done reordering** appears.
7. Press **OK** to finish reordering.

## Reset the TV to factory settings

You can restore the default picture and sound settings of your TV. Channel installation settings remain the same.

1. Press **MENU**.
2. Select **Installation ► Factory settings**.
3. **Reset** is highlighted.
4. Press **OK** to reset to factory settings.
5. Press **MENU** to exit.

## FOR DTV MODEL

1. Press the **MENU/EXIT** button to display or close the main menu.
2. Use the **Navigation Ring** to move around to select, adjust or confirm an item in the OSD (On Screen Display) menu.

Press the **MENU/EXIT** button to enter the main OSD. Adjust the items including **Picture, Sound, TV, Features,** and **Parental.** However, some function items in the menus may only be enabled in the particular source modes.

### • PICTURE MENU

The Picture menu shown below in most source modes, provides several video adjustment items for fine tuning the video display.

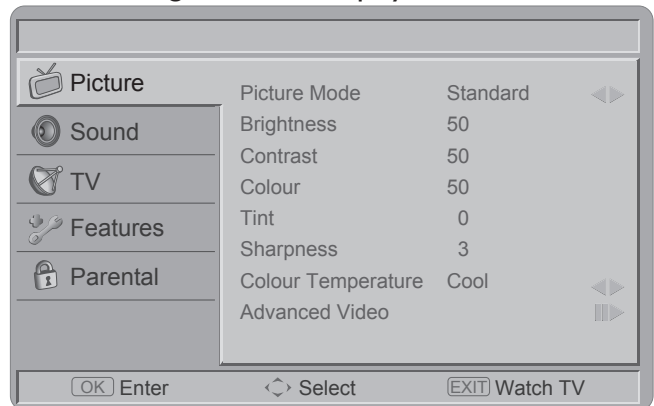

1. **Picture Mode:** To set the best picture appearance to a predefined picture setting from Standard, Vivid, Movie, Eco, or Personal.
2. **Brightness:** To brighten the dark parts of the picture.
3. **Contrast:** To sharpen the picture quality.
4. **Colour:** To add or reduce colour.
5. **Tint:** To adjust the picture tint.
6. **Sharpness:** To improve detail.
7. **Colour Temperature:** To choose between Normal (neutral), Warm (redder), and Cool (bluer).

## 8. Advanced Video:

- **DNR** - To filter out and reduces the image noise and improve picture quality. Select the effect degrees from Off, Low, Middle, High, or Auto.
- **Flash Tone** - To adjust the skin colour to be more natural.
- **Back Light** - To make the background colour brighter or darker.
- **DCR** - Dynamic Contrast Ratio (DCR) auto adjusts the brightness of the screen to show more depths in the darker areas.
- **HDMI Mode** - (HDMI only) User can select Auto/graphic/Video mode. Description as following:
  - Auto: Automatic to get device information, device will indicate sending timing is video timing or graphic timing (PC timing).
  - Graphic: Force video timing shows as graphic timing, for example: 720p shows 1280x720@60Hz; 1080i shows 1920x1080@60Hz. This mode optimises for PC input.
  - Video: Force graphic timing shows as video timing, for example: 1280x720@60Hz shows 720p; 1920x1080@60Hz shows 1080i. This mode optimises for DVD player, camcorder, and other video appliances inputs.

## • SOUND MENU

The Sound menu provides audio adjustment to modify the audio setting.

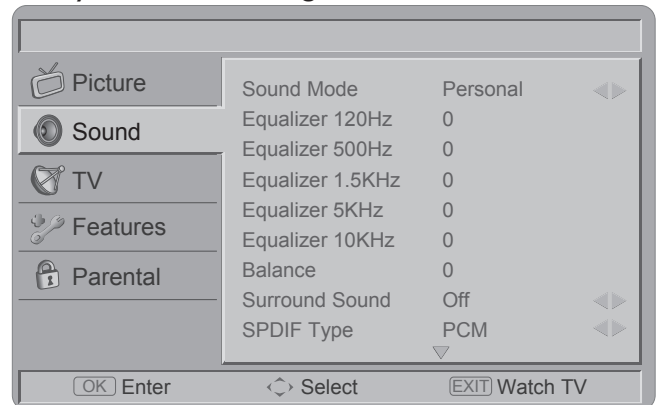

1. **Sound Mode:** To set the MFM to a predefined sound setting from Personal, Music, or Speech.
2. **Balance:** To adjust the balance between left and right channels.
3. **Surround Sound:** To add greater depth and dimension to the MFM sound.
4. **SPDIF Type:** To select the Digital Audio Out from PCM, Off, or Dolby Digital (Digital TV model only).
5. **SPDIF Delay:** SPDIF Delay function will affect Line out audio also delay at that time. The NorDig HD IRD supports the possibility to adjust the audio-delay on the SPDIF output (if available) up to 250 ms and it should be adjustable in 10ms steps, as the IRD may have several different user set-ups, resulting in different a/v delays; e.g. the IRD may be connected to several types of external audio-amplifiers and the STB may be connected to several types of external screens.
6. **Stable Sound:** Choose On or Off to adjust volume to be consistent across programmes and channels automatically.

## • TV MENU

The TV menu provides channel selection features.

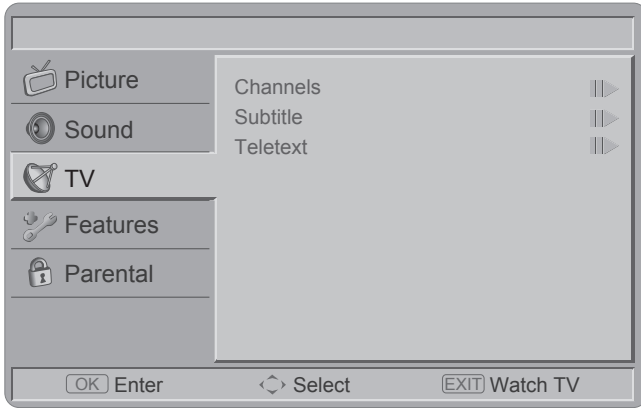

1. **Country:** To select the relevant country. This is the country you are in, or the country's channels you want to receive if you live near its borders.
2. **Channels:** Enter the channels submenu, and choose from Channel Scan, Update Scan, Single RF Scan, Analogue Manual Scan, Channel Skip, Channel Sort, Channel Edit, Decoder, and Analogue CH Fine Tune.
  - **Channel scan** - Channel Scan will re-tune the television automatically. It is recommended to run the Channel Scan periodically to ensure that all new services are added.
  - **Update scan** - Search the new channels automatically that are not in the channel list.
  - **Single RF Scan (Digital TV model only)** - Enter the Single RF Scan in the Channels submenu to scan digital channels.
  - **Analogue Manual Scan** - The television can be tuned-in manually using Analogue Manual Scan. Use the number keys to enter the Start Frequency to scan up or scan down.
  - **Channel skip** - To prevent certain programmes from being viewed by pressing CH + / - buttons on the remote control, the programme position can be skipped.

### Tip:

- The skipped programme may not be found by pressing CH + / - buttons but can be access by pressing number buttons directly.

- **Channel sort** - Changes the order of the Channel List.
- **Channel Edit** - Enters the Channel Edit in the channels submenu to edit the channel number and channel name by using the number buttons 0~9.

### Note:

- The following RC number-mapping table will not be shown on the MFM screen.

RC	Available characters
①	0 . @ 0
②	1 _ - 1
③	2 A B C a b c 2
④	3 D E F d e f 3
⑤	4 G H I g H i 4
⑥	5 J K L j k l 5
⑦	6 M N O m n o 6
⑧	7 P Q R S p q r s 7
⑨	8 T U V t u v 8
⑩	9 W X Y Z w x y z 9

- **Decoder (Analogue TV Model only)** - Channel Decode supports paid television channel; however, the channel also broadcast some un-encrypted programmes. These programmes without encryption can be viewed free of charge.
  - **Analogue Channel Fine Tune** - Selects Analogue Channel Fine Tune in the Channels submenu to adjust the frequency.
3. **Subtitle:**
    - **Analogue Subtitle** - To display the transmitted subtitle on the screen. Either this text can be permanently displayed (assuming that the service is available in the broadcast) or only when mute is active.
    - **1st and 2nd Subtitle** - Use the Digital Subtitle function when two or more subtitle languages are broadcasted. If subtitle data in a selected language is not broadcasted, the default language subtitle will be displayed.
  4. **Teletext:**
    - **Digital Teletext** - To select the teletext language.
    - **Decode Page Language** - To set the teletext language to the regional location.



## • FEATURES MENU

The Features menu in TV mode, shown below, gives the most flexibility for general demands. The various requirements in different source modes, allow some features to be hidden (disable) on the menu.

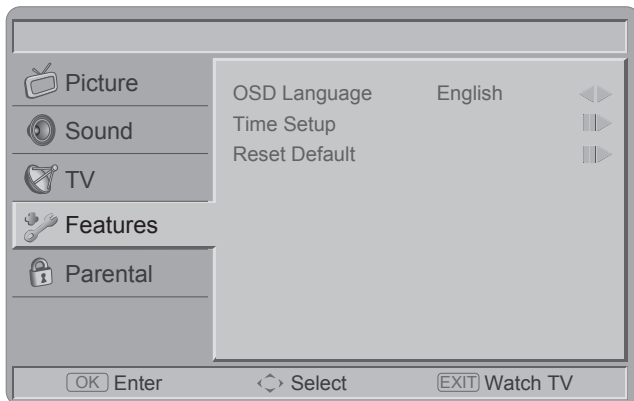

1. **OSD Language:** To select the on-screen display menu language.
2. **Time Setup:**
  - **Time Zone** - To select the time zone you are in.
  - **Time** - To set the time and date or select auto synchronization.

**Tip:**

  - Before you want to set the time and date manually make sure Auto synchronization is Off.
  - **Sleep Timer** - To set the MFM to turn itself off within a certain time.
3. **Reset Default:** To reset all MFM settings to the original factory values.

## • PARENTAL MENU

The Parental Menu enables and defines parental controls for the MFM.

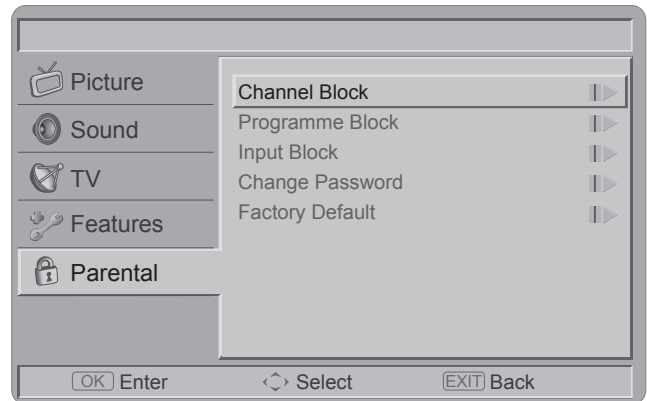

1. **Channel Block:** To block certain MFM channels.
2. **Programme Block:** To control access programmes based on age ratings. All settings apply to digital channels.
 

**Note:**

  - This function operates according to information from the broadcasting station. Therefore if the signal has no information, this function does not operate.
3. **Input Block:** To disable the specific external input signals.
4. **Change Password:** To set or change your password, follow the on-screen instructions to set it your password in. All number combinations from 0000 to 9999 are valid.
 

**Tip:**

  - Remember that 5351 is the default Change Password code. If your access code has been changed or you have forgotten the code, you can always get in by inputting the default code.
5. **Factory Default:** To clear all the settings in the parental submenu.

## LEGAL NOTICES

### Regulatory Notices – Federal Communications Commission Notice

This equipment has been tested and found to comply with the limits for a Class B digital device, pursuant to part 15 of the FCC Rules. These limits are designed to provide reasonable protection against harmful interference in a residential installation. This equipment generates, uses, and can radiate radio frequency energy and, if not installed and used in accordance with the instructions, may cause harmful interference to radio communications. However, there is no guarantee that interference will not occur in a particular installation. If this equipment does cause harmful interference to radio or television reception, which can be determined by turning the equipment off and on, the user is encouraged to try to correct the interference by one or more of the following measures:

- Reorient or relocate the receiving antenna.
- Increase the separation between the equipment and the TV.
- Connect the equipment into wall power outlet on a circuit different from that to which the receiver is connected.
- Consult the dealer or an experienced radio or television technician for help.

### Modifications

The FCC requires the user to be notified that any changes or modifications made to this device that are not expressly approved by our company may void the user's authority to operate the equipment.

### Cables

Connections to this device must be made with shielded cables with metallic RF/EMI connector hoods to maintain compliance with FCC Rules and Regulations.

### Canadian notice

This Class B digital apparatus meets all requirements of the Canadian Interference-Causing Equipment Regulations.

### Avis Canadian

Cet appareil numérique de la classe B respecte toutes les exigences du règlement sur le matériel brouilleur du Canada.

### Power Cord Set Requirements

The MFM power supply is provided with Automatic Line Switching (ALS). This feature allows the MFM to operate on input voltages between 100–120V or 200–240V.

The power cord set (flexible cord or wall plug) received with the MFM meets the requirements for use in the country where you purchased the equipment.

If you need to obtain a power cord for a different country, you should purchase a power cord that is approved for use in that country.

The power cord must be rated for the product and for the voltage and current marked on the product's electrical ratings label. The voltage and current rating of the cord should be greater than the voltage and current rating marked on the product. In addition, the cross-sectional area of the wire must be a minimum of 0.75 mm<sup>2</sup> or 18 AWG, and the length of the cord must be between 6 feet (1.8 m) and 12 feet (3.6 m). If you have questions about the type of power cord to use, contact an authorized HP service provider.

A power cord should be routed so that it is not likely to be walked on or pinched by items placed upon it or against it. Particular attention should be paid to the plug, electrical outlet, and the point where the cord exits from the product.

# TECHNICAL SPECIFICATIONS

## Acceptable Video signals through HDMI terminals

Format	Resolution	V. Frequency	H. Frequency	Pixel Clock Frequency
480i	720 x 480i	60.000Hz	15.734kHz	27.000MHz
480p	720 x 480p	60.000Hz	31.500kHz	27.000MHz /27.030MHz
576i	720 x 576i	50.000Hz	15.625kHz	27.000MHz
576p	720 x 576p	50.000Hz	31.250kHz	54.000MHz
720p	1280 x 720p	50.000Hz	37.500kHz	74.250MHz
720p	1280 x 720p	59.940 Hz / 60.000Hz	44.960kHz / 45.000kHz	74.170MHz /74.250MHz
1080i	1920 x 1080i	59.940 Hz / 60.000Hz	33.720kHz / 33.750kHz	74.170MHz /74.250MHz
1080i	1920 x 1080i	50.000Hz	28.125kHz	74.250MHz
1080p	1920 x 1080p	50.000Hz	56.250kHz	148.500MHz
1080p	1920 x 1080p	59.940 Hz / 60.000Hz	67.430kHz / 67.500kHz	148.350MHz /148.500MHz

## Acceptable PC signals through HDMI/D-SUB terminals

Format	Resolution	V. Frequency	H. Frequency	Pixel Clock Frequency
VGA	640x480	59.940Hz	31.469kHz	25.175MHz
VGA	640x480	72.809Hz	37.861kHz	31.500MHz
VGA	640x480	75.000Hz	37.500kHz	31.500MHz
VGA	720x400	70.087Hz	31.469kHz	28.322MHz
SVGA	800x600	56.250Hz	35.156kHz	36.000MHz
SVGA	800x600	60.317Hz	37.879kHz	40.000MHz
SVGA	800x600	72.188Hz	48.077kHz	50.000MHz
SVGA	800x600	75.000Hz	46.875kHz	49.500MHz
XGA	1024x768	60.004Hz	48.363kHz	65.000MHz
XGA	1024x768	70.069Hz	56.476kHz	75.000MHz
XGA	1024x768	75.029Hz	60.023kHz	78.750MHz
WXGA	1280x720	59.855Hz	44.772kHz	74.250MHz
SXGA	1280x1024	60.020Hz	63.981kHz	108.000MHz
WXGA	1440x900	60.000Hz	55.940kHz	106.500MHz
WSXGA	1680x1050	60.000Hz	65.290kHz	146.250MHz
FHD	1920x1080	60.000Hz	67.500kHz	148.500MHz

HDMI, the HDMI logo, and High-Definition Multimedia Interface are trademarks or registered trademarks of HDMI Licensing, LLC.

### NOTE:

- For PC input, for only supported PC signal can show the correct resolution on TV display.

## Signal names for mini D-sub 15 pin connector

Pin assignment for RGB/PC terminal

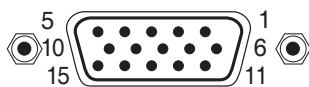

Pin No.	Signal name	Pin No.	Signal name
1	R	9	VGA-5V
2	G	10	Ground
3	B	11	NC (not connected)
4	NC (not connected)	12	VGA-SDA
5	NC (not connected)	13	H-sync
6	Ground	14	V-sync
7	Ground	15	VGA-SCL
8	Ground		

## Analogue TV Model Specifications

### Model

2310TV

### Power source

220V-240V AC, 50 Hz

### Power consumption

2310TV: 65W

### Standby (approx.)

0.5W

### Dimensions

560.3cm(W) 399.3cm(H) 175.4cm(D)

### Mass (Weight)

5.15 kg

### Net (Weight without stand)

5.13 kg

### Analogue TV system (Antenna input)

Channel coverage:  
PAL B/G DK, I  
NTSC M/N

### COMPONENT VIDEO INPUT terminals (the signal format)

480i, 480p, 576i, 576p, 720p (50/60 Hz), 1080i, 1080p (50/60 Hz) (These signal formats are converted to match the number of pixels of the LCD panel.)

### Composite Colour system (analogue TV system)

PAL, SECAM, NTSC 3.58/4.43

### Aspect ratio

16 : 9

### Visible size (diagonal)

477.41x268.41mm

### Number of pixels

1,920 (H) dots x 1,080 (V) dots

### Sound output (at 10 % distortion)

3W + 3W

### Headphone socket

R3.5mm stereo.

## Input/Output terminals

⊖ (1)	Input RCA Component Video RCA Composite Video Audio : RCA	Y, PB/CB, PR/CR CVBS L/Mono+R (shared between Component and Composite)
⊖ (2)	Input RCA/Mini-Din(4 pin) Composite Video(CVBS) +S-video Audio : RCA	L/Mono+R (shared between S-Video and Composite)
⊕ TV	Output RCA video output Audio out RCA(L+R)	
⊖ RGB/PC	Input Mini D-sub 15 pin Analogue RGB	
⊖ PC/HDMI1 / Component	Input RCA	Audio L+R
⊖ HDMI1	Input(type A) 19 pin	A/V Digital
⊖ HDMI2	Input(type A) 19 pin	A/V Digital
⊕ Digital Audio (coaxil)	Output Bitstream/PCM	
	Headphone jack 3.5 mm (Diameter) stereo	

### Operating condition

Temperature 5 °C - 35 °C

Humidity 20 % - 80 % (No moisture condensation)

- Design and specifications are subject to change without notice.
- Never service or remodel the TV by yourself. It may expose you to a fire hazard or dangerous voltages.

## Digital TV Model Specifications

### Model

2310TV

### Power source

220V-240V AC, 50 Hz

### Power consumption

2310TV: 65W

### Standby (approx.)

0.5W

### Dimensions

560.3cm(W) 399.3cm(H) 175.4cm(D)

### Mass (Weight)

5.15 kg

### Net (Weight without stand)

5.13 kg

### Analogue TV system (Antenna input)

Channel coverage:

PAL B/G	(CCIR)	VHF	0 - 12
		UHF	27 - 69
		CATV	C2, C10, C31
			S2 - S44

### Digital TV System

Compliant Standard DVB-T  
 Video Decoding MP @ ML & MP @ HL  
 Audio Decoding Dolby® Digital, MPEG (I & II)  
 Audio Sampling Rate 32, 44.1, 48 kHz

### Digital TV Terrestrial Tuner / Demodulator

Frequency 51~858 MHz  
 Loop Through 51~858 MHz  
 Bandwidth 7 MHz  
 Demodulator COFDM  
 FFT Mode 8 K  
 Constellation QPSK, 64 QAM  
 Guard Interval 1/8, 1/16  
 Inner Coding Rate 2/3, 3/4

### COMPONENT VIDEO INPUT terminals (the signal format)

480i, 480p, 576i, 576p, 720p (50/60 Hz), 1080i, 1080p (50/60 Hz) (These signal formats are converted to match the number of pixels of the LCD panel.)

### Composite Colour system (analogue TV system)

PAL, SECAM, NTSC 3.58/4.43

### Aspect ratio

16 : 9

### Visible size (diagonal)

477.41x268.41mm

### Number of pixels

1,920 (H) dots x 1,080 (V) dots

### Sound output (at 10 % distortion)

3W + 3W

### Headphone socket

R3.5mm stereo.

### Input/Output terminals

⊖ (1)	Input RCA Component Video RCA Composite Video Audio : RCA	Y, PB/CB, PR/CR CVBS L/Mono+R (shared between Component and Composite)
⊖ (2)	Input RCA/Mini-Din(4 pin) Composite Video(CVBS) +S-video Audio : RCA	L/Mono+R (shared between S-Video and Composite)
⊕ TV	Output RCA video output Audio out RCA(L+R)	
⊖ RGB/PC	Input Mini D-sub 15 pin Analogue RGB	
⊖ PC/HDMI1 / Component	Input RCA	Audio L+R
⊖ HDMI1	Input(type A) 19 pin	A/V Digital
⊖ HDMI2	Input(type A) 19 pin	A/V Digital
⊕ Digital Audio (optical + coaxial)	Output Bitstream/PCM	
	Headphone jack 3.5 mm (Diameter) stereo	

### Operating condition

Temperature 5 °C - 35 °C

Humidity 20 % - 80 % (No moisture condensation)

- Design and specifications are subject to change without notice.
- Never service or remodel the TV by yourself. It may expose you to a fire hazard or dangerous voltages.

## TROUBLESHOOTING

Please make these simple checks before calling service. These tips may save you time and money since charges for receiver installation and adjustments of customer controls are not covered under your warranty.

Symptoms	Items to Check and Actions to follow
“Ghost ” or double image	<ul style="list-style-type: none"> <li>This may be caused by obstruction to the antenna due to high rise buildings or hills. Using a highly directional antenna may improve the picture.</li> </ul>
No power	<ul style="list-style-type: none"> <li>Check if the TV's AC power cord is plugged into the mains socket.</li> <li>Unplug the TV, wait for 60 seconds. Then reinsert plug into the mains socket and turn on the TV again.</li> </ul>
No picture	<ul style="list-style-type: none"> <li>Check antenna connections at the rear of the TV to see if it is properly connected to the TV.</li> <li>Possible broadcast station trouble. Try another channel.</li> <li>Adjust the contrast and brightness settings.</li> <li>Check the Closed Captions control. Some TEXT modes could block the screen.</li> </ul>
Good picture but no sound	<ul style="list-style-type: none"> <li>Increase the VOLUME.</li> <li>Check if the TV is muted; press the MUTE button on the remote control.</li> <li>For PC operation, if a DVI to HDMI cable is used, make sure a separate audio cable is connected between the PC and MFM.</li> </ul>
Good sound but poor colour	<ul style="list-style-type: none"> <li>Adjust the contrast, colour and brightness settings.</li> </ul>
Poor picture	<ul style="list-style-type: none"> <li>Poor picture quality may occur when an activated S-VHS camera or camcorder is connected to your TV and the other peripheral at the same time. Switch off one of the peripherals.</li> </ul>
Snowy picture and noise	<ul style="list-style-type: none"> <li>Check the antenna connection.</li> </ul>
Horizontal dotted line	<ul style="list-style-type: none"> <li>This may be caused by electrical interference (e.g. hairdryer, nearby neon lights, etc.)</li> <li>Turn off the equipment.</li> </ul>
Television not responding to remote control	<ul style="list-style-type: none"> <li>Check whether the batteries are working. Replace if necessary.</li> <li>Clean the remote control sensor lens on the TV.</li> <li>You can still use the buttons at the front of your TV.</li> <li>Select the TV mode to ensure your remote control is set in the TV mode.</li> </ul>

## Online Technical Support

For the online access to technical support information, self-solve tools, online assistance, community forums of IT experts, broad multivendor knowledge base, monitoring and diagnostic tools, go to <http://www.hp.com/support>.

## Preparing to Call Technical Support

If you cannot solve a problem using the trouble shooting tips in this section, you may need to call technical support. Have the following information available when you call:

- MFM unit model number
- Serial number for the MFM unit
- Purchase date on invoice
- Conditions under which the problem occurred
- Error messages received
- Hardware configuration
- Hardware and software you are using

## TIPS

### Care of the screen

Do not rub or strike the screen with anything hard as this may scratch, mar, or damage the screen permanently.

Unplug the power cord before cleaning the screen. Dust the MFM by wiping the screen and the cabinet with a soft, clean cloth. If the screen requires additional cleaning, use a clean, damp cloth. Do not use liquid cleaners or aerosol cleaners.

### Mobile telephone warning

To avoid disturbances in picture and sound, malfunctioning of your MFM or even damage to the MFM, keep your mobile telephone away from the MFM.

### HP Recycling Program

HP encourages customers to recycle used electronic hardware, HP original print cartridges, and rechargeable batteries. For more information about recycling programs, go to <http://www.hp.com/recycle>.

## GLOSSARY

### HDTV

HDTV displays are technically defined as being capable of displaying a minimum of 720p or 1080i/p active scan lines.

### HDMI Inputs

High-Definition Multimedia Interface

### Audio / Video Inputs

Located on the rear of the receiver, these connectors (RCA phono type plug) are used for the input of audio and video signals. Designed for use with VCRs (or other accessories) in order to receive higher picture resolution and offer sound connection options.

### Menu

An on-screen listing of features shown on the TV screen is made available for user adjustments.

### RF

Radio Frequency or modulated signal design used as the carrier for television broadcasts.

### Sleep Timer

You can set a time period for which the TV will be turn off automatically.

