

HP Photosmart D110 series



Windows Help

HP Photosmart D110 series



Contents

1	HP Photosmart D110 series Help	3
2	Get to know the HP Photosmart	
	Printer parts	5
	Control panel features	6
	TouchSmart Web	6
3	How do I?	7
4	Print	
	Tips for print success	12
5	Copy and scan	
	Copy text or mixed documents	13
	Scan to a computer	15
	Tips for copy and scan success	16
6	Work with cartridges	
	Replace the cartridges	19
	Cartridge warranty information	21
	Order ink supplies	21
	Ink-backup mode	22
	Check the estimated ink levels	22
	Tips for working with print cartridges	23
7	Connectivity	
	Add the HP Photosmart to a network	25
	Tips for setting up and using a networked printer	30
9	HP support	
	Phone support period	35
	Placing a call	35
	Additional warranty options	35
	Clear the paper jam from the rear access door	35
10	Technical information	
	Notice	37
	Specifications	37
	Environmental product stewardship program	38
	Regulatory notices	42
	Regulatory wireless statements	45
	Index	49

1 HP Photosmart D110 series Help

For information about the HP Photosmart, see:

- [“How do I?”](#) on page 7
- [“Get to know the HP Photosmart”](#) on page 5
- [“Print”](#) on page 9
- [“Copy and scan”](#) on page 13
- [“Work with cartridges”](#) on page 19
- [“Connectivity”](#) on page 25
- [“Technical information”](#) on page 37

2 Get to know the HP Photosmart

- [Printer parts](#)
- [Control panel features](#)
- [TouchSmart Web](#)

Printer parts

Figure 2-1 Printer parts

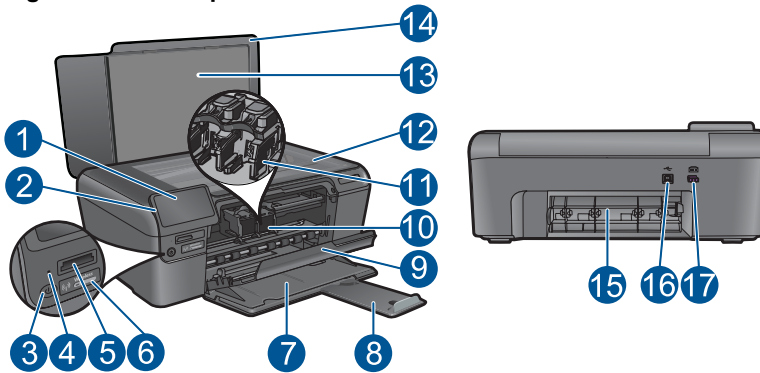

1	Color graphics display (also referred to as the display)
2	Control panel
3	On button
4	Photo light
5	Memory card slots for Memory Stick DUO and Secure Digital (SD-MMC) cards
6	Wireless button: Launches the wireless menu. Pushing and holding the wireless button launches Wi-Fi Protected Setup (WPS).
7	Paper tray
8	Paper tray extender (also referred to as the tray extender)
9	Cartridge door
10	Cartridge access area
11	Print carriage
12	Glass
13	Lid-backing
14	Lid
15	Rear door
16	Rear USB port
17	Power connection (Use only with the power adapter supplied by HP.)

Control panel features

Figure 2-2 Control panel features

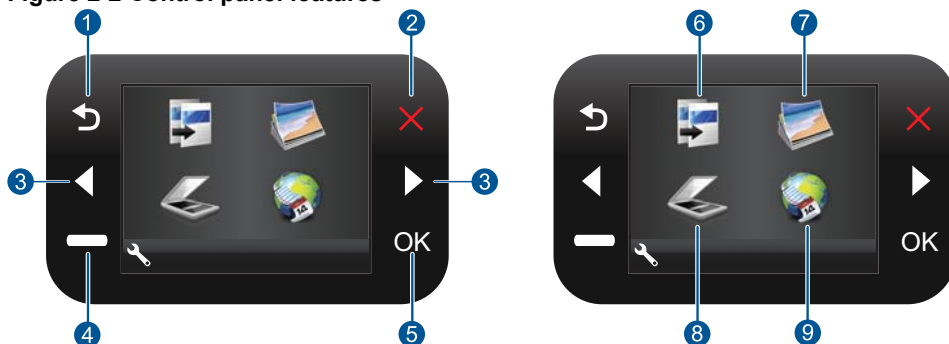

1	Back: Returns to the previous screen.
2	Cancel: Stops the current operation, restores default settings, and clears the current photo selection.
3	Directional keys: Allow you to navigate through photos and menu options.
4	Setup: Opens the Setup menu where you can change product settings and perform maintenance functions.
5	OK: Selects a menu setting, value, or photo.
6	Copy: Opens the Copy menu where you can select a copy type or change the copy settings.
7	Photo: Opens the Photo Menu.
8	Scan: Opens the Scan Destination Menu menu where you can select a destination for your scan.
9	Apps: TouchSmart Web provides a quick and easy way to access and print information from the Web, such as coupons, coloring pages, and puzzles.

TouchSmart Web

The **TouchSmart Web** Manager can be used to add new **Apps** or to remove **Apps**.

Manage Apps

- ▲ Add new **Apps**.
 - a. Press the directional keys to scroll to the Web menu option. Press **OK**.
 - b. Press the directional keys to scroll to the More menu option. Press **OK**. Check desired **Apps**. Press **OK**. Follow prompts.

3 How do I?

This section contains links to commonly performed tasks, such as printing photos, scanning, and making copies.

["TouchSmart Web"](#) on page 6

["Replace the cartridges"](#) on page 19

["Load media"](#) on page 31

["Scan to a computer"](#) on page 15

["Copy text or mixed documents"](#) on page 13

["Clear the paper jam from the rear access door"](#) on page 35

4 Print



[“Print documents”](#) on page 9



[“Print photos”](#) on page 10



[“Print envelopes”](#) on page 11

Related topics

- [“Load media”](#) on page 31
- [“Tips for print success”](#) on page 12

Print documents

Most print settings are automatically handled by the software application. You need to change the settings manually only when you change print quality, print on specific types of paper or transparency film, or use special features.

To print from a software application

1. Make sure you have paper loaded in the paper tray.
2. On the **File** menu in your software application, click **Print**.
3. Make sure the product is the selected printer.
4. If you need to change settings, click the button that opens the **Properties** dialog box. Depending on your software application, this button might be called **Properties**, **Options**, **Printer Setup**, **Printer**, or **Preferences**.



NOTE: When printing a photo, you must select options for the specific photo paper and photo enhancement.

5. Select the appropriate options for your print job by using the features available in the **Advanced**, **Printing Shortcuts**, **Features**, and **Color** tabs.



TIP: You can easily select the appropriate options for your print job by choosing one of the predefined print tasks on the **Printing Shortcuts** tab. Click a type of print task in the **Printing Shortcuts** list. The default settings for that type of print task are set and summarized on the **Printing Shortcuts** tab. If necessary, you can adjust the settings here and save your custom settings as a new printing shortcut. To save a custom printing shortcut, select the shortcut and click **Save As**. To delete a shortcut, select the shortcut and click **Delete**.

6. Click **OK** to close the **Properties** dialog box.
7. Click **Print** or **OK** to begin printing.

Related topics

- [“Load media”](#) on page 31
- [“Tips for print success”](#) on page 12

Print photos

[“Print photos saved on your computer”](#) on page 10

Print photos saved on your computer

To print a photo on photo paper

1. Remove all paper from the paper tray.
2. Place the photo paper print side down on the right side of the paper tray.

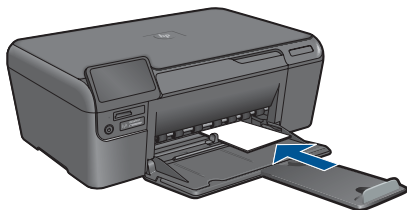

3. Slide the paper-width guide inward until it stops at the edge of the paper.
4. On the **File** menu in your software application, click **Print**.
5. Make sure the product is the selected printer.
6. Click the button that opens the **Properties** dialog box. Depending on your software application, this button might be called **Properties**, **Options**, **Printer Setup**, **Printer**, or **Preferences**.
7. Click the **Features** tab.
8. In the **Basic Options** area, from the **Paper Type** drop-down list, select **More**. Then, select the appropriate photo paper type.
9. In the **Resizing Options** area, from the **Size** drop-down list, select **More**. Then, select the appropriate paper size. If the paper size and paper type are not compatible, the printer software displays an alert and allows you to select a different type or size.
10. (Optional) Select the **Borderless printing** check box if it is not already checked. If the borderless paper size and paper type are not compatible, the product software displays an alert and allows you to select a different type or size.

11. In the **Basic Options** area, select a high print quality, such as **Best**, from the **Print Quality** drop-down list.



NOTE: To achieve the highest dpi resolution, you can use the **Maximum dpi** setting with supported types of photo paper. If **Maximum dpi** is not listed in the Print quality drop-down list, you can enable it from the **Advanced** tab.

12. In the **HP Real Life Technologies** area, click the **Photo fix** drop-down list and select from the following options:
 - **Off:** applies no **HP Real Life Technologies** to the image.
 - **Basic:** enhances low-resolution images; moderately adjusts image sharpness.
13. Click **OK** to return to the **Properties** dialog box.
14. Click **OK**, and then click **Print** or **OK** in the **Print** dialog box.



NOTE: Do not leave unused photo paper in the paper tray. The paper might start to curl, which could reduce the quality of your printout. For best results, do not allow printed photos to stack up in the paper tray.

Related topics

- [“Load media” on page 31](#)
- [“Tips for print success” on page 12](#)

Print envelopes

With the HP Photosmart, you can print on a single envelope, a group of envelopes, or label sheets designed for inkjet printers.

To print a group of addresses on labels or envelopes

1. Print a test page on plain paper first.
2. Place the test page on top of the label sheet or envelope, and hold both up to the light. Check the spacing for each block of text. Make adjustments as needed.
3. Load the labels or envelopes into the paper tray.



CAUTION: Do not use envelopes with clasps or windows. They can get stuck in the rollers and cause paper jams.

4. Slide the paper-width guide inward against the stack of labels or envelopes until the guide stops.
5. If you are printing on envelopes, do the following:
 - a. Display the print settings, and click the **Features** tab.
 - b. In the **Resizing Options** area, click the appropriate envelope size in the **Size** list.
6. Click **OK**, and then click **Print** or **OK** in the **Print** dialog box.

Related topics

- [“Load media” on page 31](#)
- [“Tips for print success” on page 12](#)

Tips for print success

Use the following tips to print successfully.

Print tips

- Use genuine HP cartridges. Genuine HP cartridges are designed for and tested with HP printers to help you produce great results, time after time.
- Make sure the cartridges have sufficient ink. To check the estimated ink levels, follow the instruction in the **Tools** menu on the display. Alternatively, you can check the ink levels in **Printer Toolbox** from the software.
- Load a stack of paper, not just one page. Use clean and flat paper of the same size. Make sure only one type of paper is loaded at a time.
- Adjust the paper-width guide in the input tray to fit snugly against all paper. Make sure the paper-width guide does not bend the paper in the input tray.
- Set the print quality and paper size settings according to the type and size of paper loaded in the input tray.
- Use print preview to check margins. Do not let the margin settings for the document exceed the printable area of the printer.
- Learn how to share your photos online and order prints. [Click here to go online for more information.](#)
- Learn about **TouchSmart Web** Manager for printing recipes, coupons, and other content from the web, simply and easily. [Click here to go online for more information.](#)

5 Copy and scan

- [Copy text or mixed documents](#)
- [Scan to a computer](#)
- [Tips for copy and scan success](#)

Copy text or mixed documents

Copy text or mixed documents

1. Do one of the following:

Make a black and white copy

- a. Load paper.
 - Load full-size paper in paper tray.

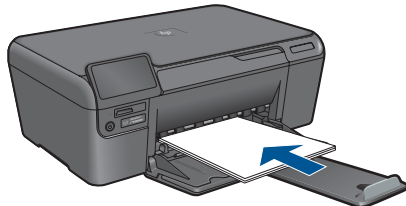

- b. Load original.
 - Lift lid on product.

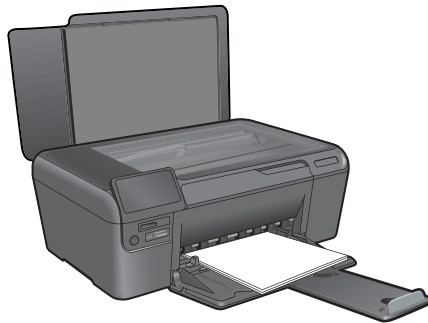

 **TIP:** To make copies of thick originals, such as books, you can remove the lid.

- Load original print side down on right front corner of glass.

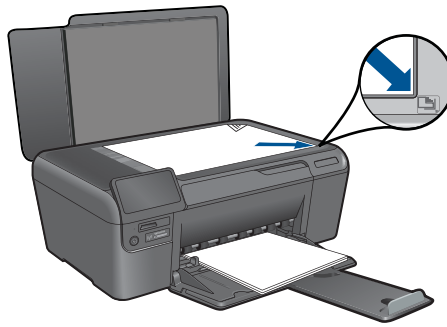

- Close lid.
- c. Select **Copy**.
 - On the Home screen, highlight **Copy**, and then press **OK**.
 - Highlight **Black Copy**, and then press **OK**.
 - Press the **Settings** button to change the copy size.
 - Press **Directional keys** to change the number of copies.
- d. Start copy.
 - Press **OK**.

Make a color copy

- a. Load paper.
 - Load full-size paper in paper tray.

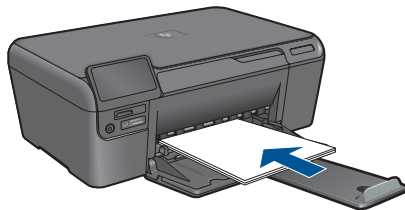

- b. Load original.
 - Lift lid on product.

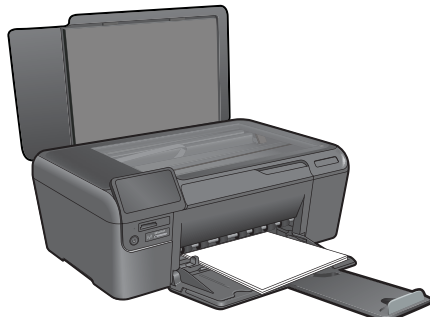

 **TIP:** To make copies of thick originals, such as books, you can remove the lid.

- Load original print side down on right front corner of glass.

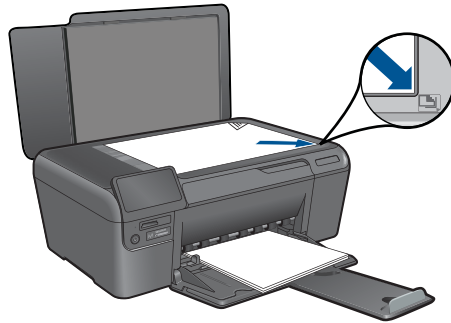

- Close lid.
- c. Select **Copy**.**
- On the Home screen, highlight **Copy**, and then press **OK**.
 - Highlight **Color Copy**, and then press **OK**.
 - Press the **Settings** button to change the copy size.
 - Press **Directional keys** to change the number of copies.
- d. Start copy.**
- Press **OK**.
- 2.** View the animation for this topic.

Related topics

[“Tips for copy and scan success” on page 16](#)

Scan to a computer

To scan to a computer

- 1.** Load original.
 - a.** Lift lid on product.

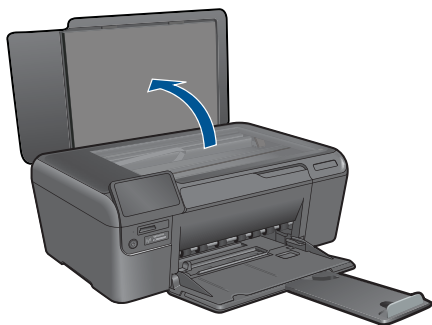

- b. Load original print side down on right front corner of glass.

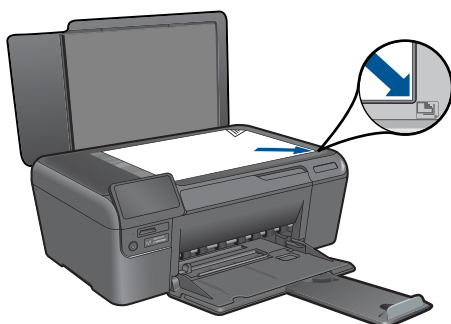

- c. Close lid.
2. Start scan.
 - a. On the Home screen, highlight **Scan**, and then press **OK**.
 - b. Highlight **Scan to PC**, and then press **OK**.
If product is network-connected, a list of available computers appears. Select computer to which you want to transfer to start the scan.
 3. View the animation for this topic.

Related topics

[“Tips for copy and scan success” on page 16](#)

Tips for copy and scan success

Use the following tips to copy and scan successfully:

- Keep the glass and the back of the lid clean. The scanner interprets anything it detects on the glass as part of the image.
- Load your original, print side down, on the right front corner of the glass.
- To copy or scan a book or other thick originals, remove the lid.
- To make a large copy of a small original, scan the original into the computer, resize the image in the scanning software, and then print a copy of the enlarged image.

- To avoid incorrect or missing scanned text, make sure the brightness is set appropriately in the software.
- If the document to be scanned has a complex layout, select framed text as the scan document setting in the software. With this setting, the text layout and formatting are retained.
- If the scanned image is incorrectly cropped, turn off the autocropping feature in the software and crop the scanned image manually.

6 Work with cartridges

- [Replace the cartridges](#)
- [Cartridge warranty information](#)
- [Order ink supplies](#)
- [Ink-backup mode](#)
- [Check the estimated ink levels](#)
- [Tips for working with print cartridges](#)

Replace the cartridges

To replace the cartridges

1. Check that power is on.
2. Remove cartridge.
 - a. Open cartridge access door.

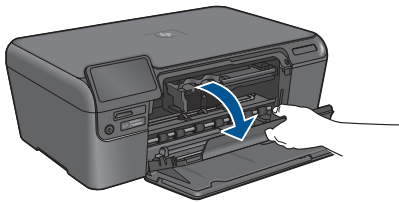

Wait for print carriage to move to center of the product.

- b. Lightly press down on the cartridge to release it, then remove it from slot.

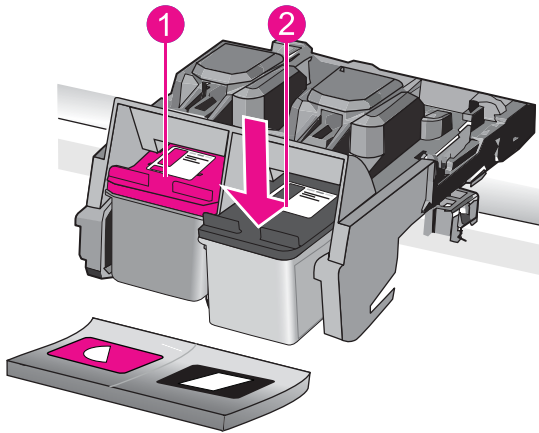

1	Cartridge slot for tri-color cartridge
2	Cartridge slot for black cartridge

- 3. Insert new cartridge.
 - a. Remove cartridge from packaging.
 - b. Remove plastic tape by using the pink pull tab.

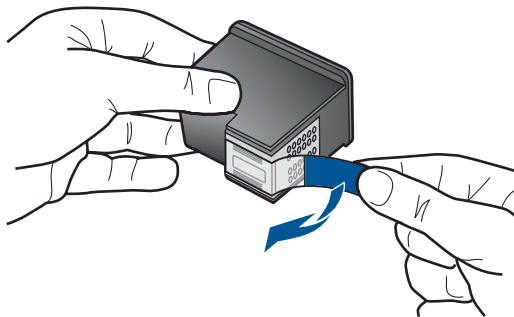

- c. Line up colored shaped icons, then slide cartridge into slot until it clicks into place.

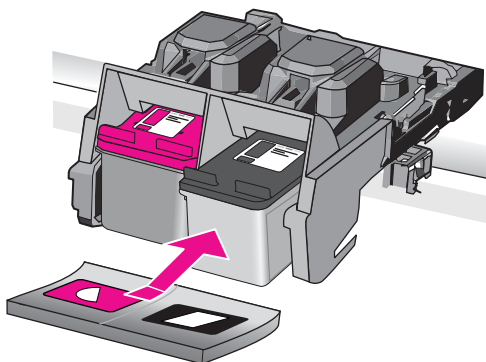

- d. Close cartridge door.

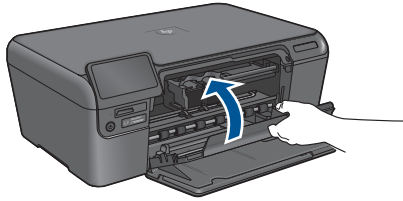

4. Align cartridges.
 - a. When prompted, press **OK** to print a cartridge alignment page.
 - b. Load page print side down on right front corner of glass, and then press **OK** to scan page.
 - c. Remove alignment page and recycle or discard it.
5. View the animation for this topic.

Related topics

- [“Order ink supplies”](#) on page 21
- [“Ink-backup mode”](#) on page 22

Cartridge warranty information

The HP cartridge warranty is applicable when the product is used in its designated HP printing device. This warranty does not cover HP ink products that have been refilled, remanufactured, refurbished, misused, or tampered with.

During the warranty period the product is covered as long as the HP ink is not depleted and the end of warranty date has not been reached. The end of warranty date, in YYYY/MM/DD format, may be found on the product as indicated:

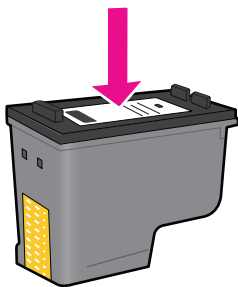

For a copy of the HP Limited Warranty Statement, see the printed documentation that came with the product.

Order ink supplies

To learn which HP supplies work with your product, order supplies online, or create a printable shopping list, open HP Solution Center, and select the online shopping feature.

Cartridge information and links to online shopping also appear on ink alert messages. In addition, you can find cartridge information and order online by visiting www.hp.com/buy/supplies.

 **NOTE:** Ordering cartridges online is not supported in all countries/regions. If it is not supported in your country/region, contact a local HP reseller for information about purchasing cartridges.

Ink-backup mode

Use the ink-backup mode to operate the HP Photosmart with only one print cartridge. The ink-backup mode is initiated when a print cartridge is removed from the print cartridge carriage. During ink-backup mode, the product can only print jobs from the computer.

 **NOTE:** When the HP Photosmart operates in ink-backup mode, a message is displayed on screen. If the message is displayed and two print cartridges are installed in the product, verify that the protective piece of plastic tape has been removed from each print cartridge. When plastic tape covers the print cartridge contacts, the product cannot detect that the print cartridge is installed.

For more information about ink-backup mode, see the following topics:

- [“Ink-backup mode output” on page 22](#)
- [“Exit ink-backup mode” on page 22](#)

Ink-backup mode output

Printing in ink-backup mode slows the printer and affects the quality of printouts.

Installed print cartridge	Result
Black print cartridge	Colors print as grayscale.
Tri-color print cartridge	Colors print but black is grayed and is not a true black.

Exit ink-backup mode

Install two print cartridges in the HP Photosmart to exit ink-backup mode.

Related topics

[“Replace the cartridges” on page 19](#)

Check the estimated ink levels

You can easily check the ink supply level to determine how soon you might need to replace a cartridge. The ink supply level shows an estimate of the amount of ink remaining in the cartridges.



NOTE: If you have installed a refilled or remanufactured cartridge, or a cartridge that has been used in another printer, the ink level indicator might be inaccurate or unavailable.

NOTE: Ink level warnings and indicators provide estimates for planning purposes only. When you receive a low-ink warning message, consider having a replacement cartridge available to avoid possible printing delays. You do not have to replace the cartridges until the print quality is unacceptable.

NOTE: Ink from the cartridges is used in the printing process in a number of different ways, including in the initialization process, which prepares the product and cartridges for printing, and in printhead servicing, which keeps print nozzles clear and ink flowing smoothly. In addition, some residual ink is left in the cartridge after it is used. For more information, see www.hp.com/go/inkusage.

To check the ink levels from the HP Photosmart Software

1. In the HP Solution Center, click **Settings**, point to **Print Settings**, and then click **Printer Toolbox**.



NOTE: You can also open the **Printer Toolbox** from the **Print Properties** dialog box. In the **Print Properties** dialog box, click the **Features** tab, and then click the **Printer Services** button.

The **Printer Toolbox** appears.

2. Click the **Estimated Ink Level** tab.
The estimated ink levels for the print cartridges appear.

Related topics

[“Order ink supplies” on page 21](#)

Tips for working with print cartridges

Use the following tips to work with print cartridges:

- Use the correct print cartridges for your printer. For a list of compatible print cartridges, see the printed documentation that came with the printer. Alternatively, look in **Printer Toolbox** in the software.
- To install print cartridges, verify that the protective piece of plastic tape has been removed from each print cartridge. When plastic tape covers the print cartridge contacts, the printer cannot detect that the print cartridge is installed.
- Insert the print cartridges into the correct slots. Match the color and icon of each cartridge to the color and icon for each slot. Make sure both cartridges snap down into place.
- Use genuine HP print cartridges. Genuine HP print cartridges are designed for and tested with HP printers to help you produce great results, time after time.
- Use the ink-backup mode to operate the printer by using only one print cartridge. The ink-backup mode is initiated when a print cartridge is removed from the print cartridge carriage. During ink-backup mode, the printer can only print jobs from the computer.

- Consider getting replacement print cartridges when you receive a low-ink warning message. This avoids possible printing delays. You do not need to replace the print cartridges until print quality becomes unacceptable.
- Make sure the printhead is clean. Follow the instructions from **Tools** menu on the printer display. Alternatively, look in **Printer Toolbox** in the software.
- After you insert new print cartridges, align the printer for best print quality. Follow the instructions from **Tools** menu on the printer display. Alternatively, look in **Printer Toolbox** in the software.

7 Connectivity

Add the HP Photosmart to a network

- [WiFi Protected Setup \(WPS\)](#)
- [Wireless with a router \(infrastructure network\)](#)
- [Wireless without a router \(ad hoc connection\)](#)
- [Install the software for a network connection](#)

WiFi Protected Setup (WPS)

To connect the HP Photosmart to a wireless network using WiFi Protected Setup (WPS), you will need the following:

- A wireless 802.11 network that includes a WPS-enabled wireless router or access point.
- A desktop computer or laptop with either wireless networking support, or a network interface card (NIC). The computer must be connected to the wireless network that you intend to install the HP Photosmart on.

To connect the HP Photosmart using WiFi Protected Setup (WPS)

1. Do one of the following:

Use Push Button (PBC) method

- a. Set up wireless connection.
 - Press and hold the Wireless button.
 - Press corresponding button on WPS-enabled router or other networking device.
 - Press **OK**.
- b. Install software.

 **NOTE:** The product begins a timer for approximately two minutes in which the corresponding button on the networking device needs to be pressed.

Use PIN method

- a. Set up wireless connection.
 - Press the Wireless button.
 - Highlight Wireless Settings. Press **OK**.
 - Highlight WiFi Protected Setup. Press **OK**.
 - Highlight PIN. Press **OK**.
The device displays a PIN.
 - Enter the PIN on WPS-enabled router or other networking device.
 - Press **OK**.
- b. Install software.



NOTE: The product begins a timer for approximately two minutes in which the PIN needs to be entered on the networking device.

2. View the animation for this topic.

Related topics

- [“Install the software for a network connection” on page 29](#)
- [“Tips for setting up and using a networked printer” on page 30](#)

Wireless with a router (infrastructure network)

To connect the HP Photosmart to an integrated wireless WLAN 802.11 network, you will need the following:

- A wireless 802.11 network that includes a wireless router or access point.
- A desktop computer or laptop with either wireless networking support, or a network interface card (NIC). The computer must be connected to the wireless network that you intend to install the HP Photosmart on.
- Broadband Internet access (recommended) such as cable or DSL.
If you connect the HP Photosmart on a wireless network that has Internet access, HP recommends that you use a wireless router (access point or base station) that uses Dynamic Host Configuration Protocol (DHCP).
- Network name (SSID).
- WEP key or WPA Passphrase (if needed).

To connect the product with the Wireless Setup Wizard

1. Write down your network name (SSID) and WEP key or WPA passphrase.
2. Turn on wireless radio.
 - a. Unplug the network cable.
 - b. Touch **Setup**.
 - c. Touch **Network**.
 - d. Touch **Wireless Radio**, and then touch **On**.
3. Start Wireless Setup Wizard.
 - ▲ Touch Network Setup Wizard.
4. Connect to wireless network.
 - ▲ Select your network from the list of detected networks.
5. Follow prompts.
6. Install software.
7. View the animation for this topic.

Related topics

- [“Install the software for a network connection” on page 29](#)
- [“Tips for setting up and using a networked printer” on page 30](#)

Wireless without a router (ad hoc connection)

Use this section if you want to connect the HP Photosmart to a wireless-capable computer without using a wireless router or access point.

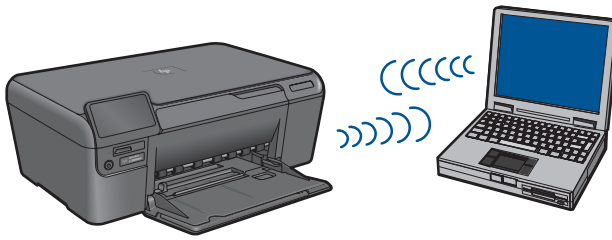

There are two methods you can use to connect the HP Photosmart to your computer using an ad hoc wireless network connection. Once connected, you can install the HP Photosmart software.

Turn on the wireless radio for the HP Photosmart and the wireless radio on your computer. On your computer, connect to the network name (SSID) **hp (product model).(6-digit unique identifier)**, which is the default ad hoc network created by the HP Photosmart. The 6-digit identifier is unique to each printer.

OR

Use an ad hoc network profile on your computer to connect to the product. If your computer is not currently configured with an ad hoc network profile, consult the Help file for your computer Operating System for the proper method to create an ad hoc profile on your computer. Once the ad hoc network profile has been created, insert the installation CD that came with the product and install the software. Connect to the ad hoc network profile you created on your computer.

 **NOTE:** An ad hoc connection can be used if you do not have a wireless router or access point but do have a wireless radio on your computer. However, an ad hoc connection may result in a lower level of network security and possibly reduced performance when compared to an infrastructure network connection using a wireless router or access point.

To connect the HP Photosmart to a Windows computer with an ad hoc connection, the computer must have a wireless network adapter and an ad hoc profile. Create a network profile for a Windows Vista or Windows XP computer using the directions below.

 **NOTE:** The product comes configured with a network profile with **hp (product model).(6-digit unique identifier)** as the network name (SSID). However, for security and privacy HP recommends you create a new network profile on your computer as described here.

To create a network profile (Windows Vista)

 **NOTE:** The product comes configured with a network profile with **hp (product model).(6-digit unique identifier)** as the network name (SSID). However, for security and privacy HP recommends you create a new network profile on your computer as described here.

1. In the **Control Panel**, double-click **Network and Internet**, then **Network and Sharing Center**.
2. In the **Network and Sharing Center** (under **Tasks** on the left), select **Set up a connection or network**.
3. Choose the connection option **Set up a wireless ad hoc (computer-to-computer) network**, then click **Next**. Read the description and warnings about ad hoc networks, then click **Next>**.
4. Enter details, including **Network name** (the SSID for your ad hoc connection), **Security type**, and **SecurityPassphrase**. If you are going to save this network connection, check **Save this network**. Make a note of the SSID and the Security key/Passphrase for future reference. Click **Next**.
5. Continue to follow the prompts to complete setup of the ad hoc network connection.

To create a network profile (Windows XP)

 **NOTE:** The product comes configured with a network profile with **hp (product model).(6-digit unique identifier)** as the network name (SSID). However, for security and privacy HP recommends you create a new network profile on your computer as described here.

1. In the **Control Panel**, double-click **Network Connections**.
2. On the **Network Connections** window, right-click the **Wireless Network Connection**. If you see **Enable** on the pop-up menu, select it. Otherwise, if you see **Disable** on the menu, the wireless connection is already enabled.
3. Right-click the **Wireless Network Connection** icon, and then click **Properties**.
4. Click the **Wireless Networks** tab.
5. Select the **Use Windows to configure my wireless network settings** check box.
6. Click **Add**, and then do the following:
 - a. In **Network name (SSID)** box, type in a unique network name of your choice.

 **NOTE:** The network name is case sensitive, so it is important to remember any uppercase (capital) and lowercase (small) letters.

- b. If there is a **Network Authentication** list, select **Open**. Otherwise, go to the next step.
- c. In the **Data encryption** list, select **WEP**.
- d. Make sure that the check box is **not** selected next to **The key is provided for me automatically**. If it is selected, click the check box to clear it.
- e. In the **Network key** box, type a WEP key that has **exactly 5** or **exactly 13** alphanumeric (ASCII) characters. For example, if you enter 5 characters, you might enter **ABCDE** or **12345**. Or, if you enter 13 characters, you might enter **ABCDEF1234567**. (12345 and ABCDE are examples only. Select a combination of your choosing.)

Alternatively, you can use HEX (hexadecimal) characters for the WEP key. A HEX WEP key must be 10 characters for 40 bit encryption, or 26 characters for 128 bit encryption.

- f. In the **Confirm network key** box, type the same WEP key you typed in the previous step.

 **NOTE:** You must remember the exact uppercase (capital) and lowercase (small) letters. If you enter your WEP key incorrectly on the product, the wireless connection will fail.

- g. Write down the WEP key exactly as you typed it, including uppercase and lowercase letters.
- h. Select the check box for **This is a computer-to-computer (ad hoc) network; wireless access points are not used.**
- i. Click **OK** to close the **Wireless network properties** window, and then click **OK** again.
- j. Click **OK** again to close the **Wireless Network Properties Connection** window.

Related topics

- [“Install the software for a network connection” on page 29](#)
- [“Tips for setting up and using a networked printer” on page 30](#)

Install the software for a network connection

Use this section to install the HP Photosmart software on a computer connected to a network. Before you install the software, make sure you have connected the HP Photosmart to a network. If the HP Photosmart has not been connected to a network, follow the onscreen instructions during the software installation to connect the product to the network.

 **NOTE:** If your computer is configured to connect to a series of network drives, make sure that your computer is currently connected to these drives before installing the software. Otherwise, the HP Photosmart software installer might try to use one of the reserved drive letters and you will not be able to access that network drive on your computer.

NOTE: Installation time can range from 20 to 45 minutes depending on your operating system, the amount of available space, and the processor speed of your computer.

To install the Windows HP Photosmart Software on a networked computer

1. Quit all applications running on your computer.
2. Insert the Windows CD that came with the product into the CD-ROM drive on your computer and follow the onscreen instructions.
3. If a dialog box about firewalls appears, follow the instructions. If you see firewall pop-up messages, you must always accept or allow the pop-up messages.
4. On the **Connection Type** screen, select an appropriate option, and then click **Next**. The **Searching** screen appears as the Setup program searches for the product on the network.
5. On the **Printer Found** screen, verify that the printer description is correct. If more than one printer is found on the network, the **Printers Found** screen appears. Select the product you want to connect.

6. Follow the prompts to install the software.
When you have finished installing the software, the product is ready for use.
7. To test your network connection, go to your computer and print a self-test report to the product.

Tips for setting up and using a networked printer

Use the following tips to set up and use a networked printer:

- When setting up the wireless networked printer, make sure your wireless router or access point is powered on. The printer searches for wireless routers, then lists the detected network names on the display.
- When entering the WEP or WPA key, use the button next to **Change Mode** on the lower left to switch among Alpha Keypad, Numeric Keypad, and Symbol Keypad.
- To verify the wireless connection, check the wireless radio light in the **Wireless Settings** menu on the display. If the light is off, select **Enable Wireless** to enable the wireless connection. It also displays the IP address of the printer.
- If your computer is connected to a Virtual Private Network (VPN), you need to disconnect from the VPN before you can access any other device on your network., including the printer.
- Learn how to find your network security settings. [Click here to go online for more information.](#)
- Learn about the Network Diagnostic Utility and other troubleshooting tips. [Click here to go online for more information.](#)
- Learn how to change from a USB to wireless connection. [Click here to go online for more information.](#)
- Learn how to work with your firewall and anti-virus programs during printer setup. [Click here to go online for more information.](#)

8 Paper basics

Load media

1. Do one of the following:

Load small-size paper

- a. Lower paper tray.
 - Slide paper-width guide outwards.

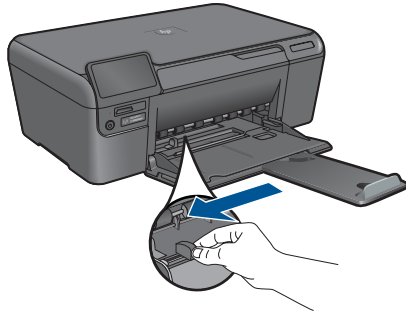

- b. Load paper.
 - Insert stack of photo paper into paper tray with short edge forward and print side down.

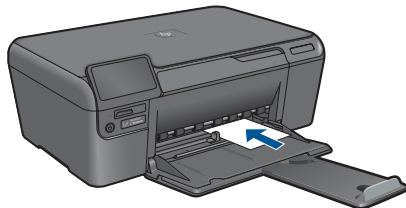

- Slide stack of paper forward until it stops.

 **NOTE:** If the photo paper you are using has perforated tabs, load photo paper so that tabs are closest to you.

- Slide paper-width guide inward until it stops at edge of paper.

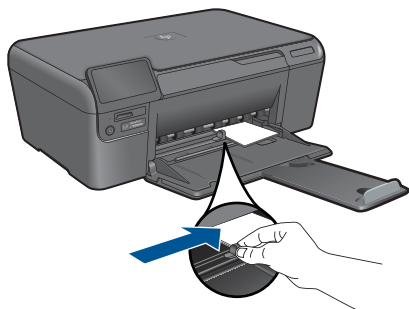
**Load full-size paper**

- a. Lower paper tray.
 - Slide paper-width guide outwards.

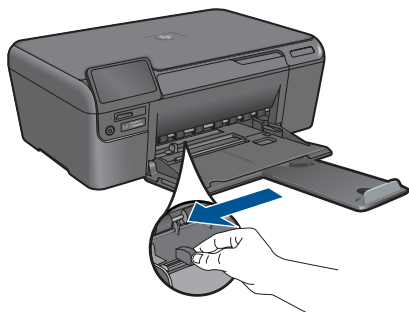

- b. Load paper.
 - Insert stack of paper into paper tray with short edge forward and print side down.

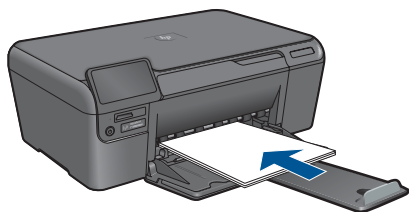

- Slide stack of paper forward until it stops.
- Slide paper-width guide inward until it stops at edge of paper.

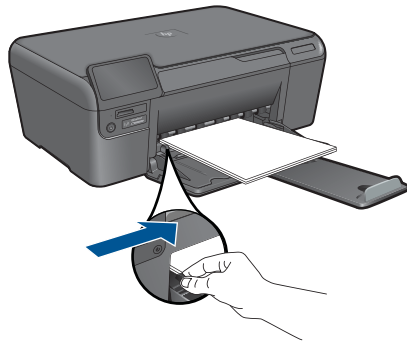

2. View the animation for this topic.

9 HP support

- [Phone support period](#)
- [Placing a call](#)
- [Additional warranty options](#)
- [Clear the paper jam from the rear access door](#)

Phone support period

One year of phone support is available in North America, Asia Pacific, and Latin America (including Mexico). To determine the duration of phone support in Europe, the Middle East, and Africa, go to HP.com/support. Standard phone company charges apply.

Placing a call

Call HP support while you are in front of the computer and the product. Be prepared to provide the following information:

- Product name (HP Photosmart D110 series)
- Serial number (located on the back or bottom of the product)
- Messages that appear when the situation occurs
- Answers to these questions:
 - Has this situation happened before?
 - Can you re-create it?
 - Did you add any new hardware or software to your computer at about the time that this situation began?
 - Did anything else occur prior to this situation (such as a thunderstorm, product was moved, etc.)?

For the list of support phone numbers, visit HP.com/support.

Additional warranty options

Extended service plans are available for the HP Photosmart at additional costs. Go to HP.com/support, select your country/region and language, then explore the services and warranty area for information about the extended service plans.

Clear the paper jam from the rear access door

To clear a paper jam from the rear access door

1. Turn product off.
2. Remove rear door.



- 3. Remove jammed paper.
- 4. Replace rear door.

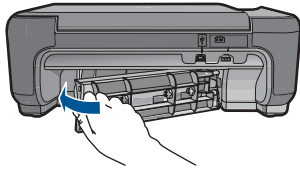

- 5. Turn on product.
- 6. Try printing again.

10 Technical information

The technical specifications and international regulatory information for the HP Photosmart are provided in this section.

For additional specifications, see the printed documentation that came with the HP Photosmart.

This section contains the following topics:

- [Notice](#)
- [Specifications](#)
- [Environmental product stewardship program](#)
- [Regulatory notices](#)
- [Regulatory wireless statements](#)

Notice

Hewlett-Packard Company notices

The information contained in this document is subject to change without notice.

All rights reserved. Reproduction, adaptation, or translation of this material is prohibited without prior written permission of Hewlett-Packard, except as allowed under copyright laws. The only warranties for HP products and services are set forth in the express warranty statements accompanying such products and services. Nothing herein should be construed as constituting an additional warranty. HP shall not be liable for technical or editorial errors or omissions contained herein.

© 2009 Hewlett-Packard Development Company, L.P.

Microsoft, Windows, Windows XP, and Windows Vista are U.S. registered trademarks of Microsoft Corporation.

Windows 7 is either a registered trademark or trademark of Microsoft Corporation in the United States and/or other countries.

Intel and Pentium are trademarks or registered trademarks of Intel Corporation or its subsidiaries in the United States and other countries.

Specifications

Technical specifications for the HP Photosmart are provided in this section. For complete product specifications, see the Product Data Sheet at HP.com/support.

System requirements

Software and system requirements are located in the Readme file.

For information about future operating system releases and support, visit the HP online support Web site at HP.com/support.

Environmental specifications

- Recommended operating temperature range: 15 °C to 32 °C (59 °F to 90 °F)
- Allowable operating temperature range: 5 °C to 40 °C (41 °F to 104 °F)
- Humidity: 20% to 80% RH non-condensing (recommended); 28 °C maximum dewpoint
- Non-operating (Storage) temperature range: -25 °C to 60 °C (13 °F to 140 °F)
- In the presence of high electromagnetic fields, it is possible the output from the HP Photosmart may be slightly distorted
- HP recommends using a USB cable less than or equal to 3 m (10 feet) in length to minimize injected noise due to potential high electromagnetic fields

Paper specifications

Type	Paper weight	Paper tray
Plain paper	20 to 24 lb. (75 to 90 gsm)	Up to 80 (20 lb. paper)

Type	Paper weight	Paper tray*
Legal paper	20 to 24 lb. (75 to 90 gsm)	Up to 80 (20 lb. paper)
Index cards	110 lb. index max (200 gsm)	Up to 30
Hagaki cards	110 lb. index max (200 gsm)	Up to 40
Envelopes	20 to 24 lb. (75 to 90 gsm)	Up to 10
5 x 7 inch (13 x 18 cm) Photo paper	145 lb. (236 gsm)	Up to 30
4 x 6 inch (10 x 15 cm) Photo paper	145 lb. (236 gsm)	Up to 30
8.5 x 11 inch (216 x 279 mm) Photo paper	145 lb. (236 gsm)	Up to 30

* Maximum capacity.



NOTE: For a complete list of supported media sizes, see the printer driver.

Print specifications

- Print speeds vary according to the complexity of the document
- Panorama-size printing
- Method: drop-on-demand thermal inkjet
- Language: PCL3 GUI

Scan specifications

- Image editor included
- Twain-compliant software interface
- Resolution: up to 1200 x 2400 ppi optical; 19200 ppi enhanced (software)
For more information about ppi resolution, see the scanner software.
- Color: 48-bit color, 8-bit grayscale (256 levels of gray)
- Maximum scan size from glass: 21.6 x 29.7 cm (8.5 x 11.7 inches)

Copy specifications

- Digital image processing
- Maximum number of copies varies by model
- Copy speeds vary according to the complexity of the document and model

Print resolution

To find out about the printer resolution, see the printer software.

Cartridge yield

Visit www.hp.com/go/learnaboutsupplies for more information on estimated cartridge yields.

Environmental product stewardship program

Hewlett-Packard is committed to providing quality products in an environmentally sound manner. Design for recycling has been incorporated into this product. The number of materials has been kept to a minimum while ensuring proper functionality and reliability. Dissimilar materials have been designed to separate easily. Fasteners and other connections are easy to locate, access, and remove using common tools. High priority parts have been designed to access quickly for efficient disassembly and repair.

For more information, visit HP's Commitment to the Environment Web site at:

www.hp.com/hpinfo/globalcitizenship/environment/index.html

This section contains the following topics:

- [Eco-Tips](#)
- [Paper use](#)
- [Plastics](#)
- [Material safety data sheets](#)
- [Recycling program](#)
- [Power consumption](#)
- [HP inkjet supplies recycling program](#)
- [Power consumption](#)
- [Disposal of waste equipment by users in private households in the European Union](#)
- [Chemical Substances](#)

Eco-Tips

HP is committed to helping customers reduce their environmental footprint. HP has provided the Eco-Tips below to help you focus on ways to assess and reduce the impact of your printing choices. In addition to specific features in this product, please visit the HP Eco Solutions web site for more information on HP's environmental initiatives.

www.hp.com/hpinfo/globalcitizenship/environment/

Your product's Eco features

- **Smart Web printing:** The HP Smart Web Printing interface includes a **Clip Book** and **Edit Clips** window where you can store, organize, or print clips you have gathered from the Web.
- **Energy Savings information:** To determine the ENERGY STAR® qualification status for this product, see "[Power consumption](#)" on page 40.
- **Recycled Materials:** For more information regarding recycling of HP products, please visit: www.hp.com/hpinfo/globalcitizenship/environment/recycle/

Paper use

This product is suited for the use of recycled paper according to DIN 19309 and EN 12281:2002.

Plastics

Plastic parts over 25 grams are marked according to international standards that enhance the ability to identify plastics for recycling purposes at the end of product life.

Material safety data sheets

Material safety data sheets (MSDS) can be obtained from the HP Web site at:

www.hp.com/go/msds

Recycling program

HP offers an increasing number of product return and recycling programs in many countries/regions, and partners with some of the largest electronic recycling centers throughout the world. HP conserves resources by reselling some of its most popular products. For more information regarding recycling of HP products, please visit:

www.hp.com/hpinfo/globalcitizenship/environment/recycle/

Power consumption

Hewlett-Packard printing and imaging equipment marked with the ENERGY STAR® logo is qualified to the U.S. Environmental Protection Agency's ENERGY STAR specifications for imaging equipment. The following mark will appear on ENERGY STAR qualified imaging products:



Additional ENERGY STAR qualified imaging product model information is listed at: www.hp.com/go/energystar

HP inkjet supplies recycling program

HP is committed to protecting the environment. The HP Inkjet Supplies Recycling Program is available in many countries/regions, and lets you recycle used print cartridges and ink cartridges free of charge. For more information, go to the following Web site:

www.hp.com/hpinfo/globalcitizenship/environment/recycle/

Power consumption

Power usage drops significantly while in Sleep mode, which saves natural resources and saves money without affecting the high performance of this product. To determine the ENERGY STAR® qualification status for this product see the Product Data Sheet or Specifications Sheet. Qualified products are also listed at www.hp.com/go/energystar.

Disposal of waste equipment by users in private households in the European Union



Disposal of Waste Equipment by Users in Private Households in the European Union

This symbol on the product or on its packaging indicates that this product must not be disposed of with your other household waste. Instead, it is your responsibility to dispose of your waste equipment by handing it over to a designated collection point for the recycling of waste electrical and electronic equipment. The separate collection and recycling of your waste equipment at the time of disposal will help to conserve natural resources and ensure that it is recycled in a manner that protects human health and the environment. For more information about where you can drop off your waste equipment for recycling, please contact your local city office, your household waste disposal service or the shop where you purchased the product.

Evacuación de los equipos eléctricos y electrónicos por parte de los usuarios domésticos en la Unión Europea

La presencia de este símbolo en el producto o en su embalaje indica que este producto no puede ser desechado con los residuos domésticos. En su lugar, es su responsabilidad eliminar los residuos de su equipo eléctrico y electrónico. La recogida separada de este tipo de residuos ayudará a conservar los recursos naturales y a garantizar que se reciclen de una manera que proteja la salud humana y el medio ambiente. Para obtener más información sobre dónde puede dejar estos residuos para su reciclado, póngase en contacto con las autoridades locales de su ciudad, con el servicio de gestión de residuos domésticos o con la tienda donde adquirió el producto.

Entsorgung von Elektrogeräten durch Benutzer in privaten Haushalten in der EU

Dieses Symbol auf dem Produkt oder dessen Verpackung zeigt an, dass das Produkt nicht zusammen mit dem Restmüll entsorgt werden darf. Es obliegt daher Ihrer Verantwortung, das Gerät an einer entsprechenden Stelle für die Entsorgung oder Wiederverwertung von Elektrogeräten oder Alt-Alt abzugeben (z.B. an Wertstoffhof). Eine separate Sammlung und das Recycling Ihrer alten Elektrogeräte zum Zeitpunkt ihrer Entsorgung trägt zum Schutz der Umwelt bei und gewährleistet, dass sie auf eine Art und Weise recycelt werden, die keine Gefährdung für die Gesundheit des Menschen und der Umwelt darstellt. Weitere Informationen darüber, wo Sie alte Elektrogeräte zum Recyceln abgeben können, erhalten Sie bei den örtlichen Behörden, Wertstoffhöfen oder dort, wo Sie das Gerät erworben haben.

Smaltimento di apparecchiature da rottamare da parte di privati nell'Unione Europea

Questo simbolo che appare sul prodotto o sulla confezione indica che il prodotto non deve essere smaltito assieme agli altri rifiuti domestici. Gli utenti devono provvedere allo smaltimento delle apparecchiature da rottamare in fase di smaltimento favorendo la conservazione delle risorse naturali e garantendo che tali apparecchiature vengano rottamate nel rispetto dell'ambiente e della tutela della salute. Per ulteriori informazioni sui punti di raccolta delle apparecchiature da rottamare, contattare il proprio comune di residenza, il servizio di smaltimento dei rifiuti locali o il negoziante presso il quale è stato acquistato il prodotto.

Eliminación de residuos de aparatos eléctricos y electrónicos por parte de usuarios domésticos en la Unión Europea

Este símbolo en el producto o en el embalaje indica que el producto junto con los residuos domésticos. Por el contrario, si debe eliminar este tipo de residuos, es responsable de llevarlos entregando en un punto de recogida designado de residuos de aparatos eléctricos y electrónicos. El reciclaje y la recogida por separado de estos residuos en el momento de la eliminación ayudará a preservar recursos naturales y a garantizar que el reciclaje proteja la salud y el medio ambiente. Si desea información adicional sobre los lugares donde puede dejar estos residuos para su reciclado, póngase en contacto con las autoridades locales de su ciudad, con el servicio de gestión de residuos domésticos o con la tienda donde adquirió el producto.

Likvidace vyloučeného zařízení uživateli v domácnosti v zemích EU

Tato značka na produktu nebo na jeho obalu označuje, že tento produkt nesmí být likvidován společně s ostatními domácími odpady. Odpovědností za to, že vyloučené zařízení bude odstraněno způsobem, který chrání životní prostředí, je recyklace vyloučeného zařízení. Likvidace vyloučeného zařízení samostatným způsobem přispívá k ochraně přírodních zdrojů a zajišťuje, že recyklace proběhne způsobem chránícím lidské zdraví a životní prostředí. Další informace o tom, kam můžete vyloučené zařízení předat k recyklaci, můžete získat od místních samospráv, od společnosti provádějící vvoz a likvidaci domovního odpadu nebo v obchodě, kde jste produkt zakoupili.

Bortskaffelse af affaldsudstyr for brugere i private husholdninger i EU

Dette symbol på produktet eller på dets emballage indikerer, at produktet ikke må bortskaffes sammen med andet husholdningsaffald. I stedet er det din ansvar for bortskaffelse af affaldsudyret ved at afleverer det til et særligt opsamlingspunkt for elektrisk og elektronisk affald. Den separate indsamling og genbrug af affaldsudyret på tidspunktet for bortskaffelse er med til at bevare naturlige ressourcer og sikrer, at genbrug finder sted på en måde, der beskytter menneskers helbreds samt miljøet. Hvis du vil vide mere om, hvor du kan aflevere dit affaldsudyret til genbrug, kan du kontakte lokale myndigheder eller den forretning, hvor du købte produktet.

Afoer van afgedankte apparatuur door gebruikers in particuliere huishoudens in de Europese Unie

Dit symbool op het product of de verpakking geeft aan dat dit product niet mag worden afgevoerd met het huishoudelijk afval. Het is uw verantwoordelijkheid uw afgedankte apparatuur of de leverer op een aangewezen inzamelpunt voor de recycling van afgedankte elektrische en elektronische apparatuur. De gescheiden inzameling en verwerking van afgedankte apparatuur draagt bij tot het sparen van natuurlijke bronnen en het behoud van de volkgezondheid en het milieu. Voor meer informatie over waar u uw afgedankte apparatuur kunt inleveren voor recycling kunt u contact opnemen met het gemeentebureau in uw woonplaats, de reinigingsdienst of de winkel waar u het product hebt aangekocht.

Errompammadistes kasutuse lõpetamisel kõrvaldada seadmed käitlemise Euroopa Liidus

Täna kaetud sümbol toetab teie tootmis- ja pakendamise tegevust, mis näitab, et see toode ei saa hävitada tavajäätmete hulka. Teie lohus on viia tarbeks muundatud seadme selleks ettenahuld elektrilise ja elektroonikaseadmete üliiseseisustamiseks. Üliiseseisustamine seadmete eraldi kogumine ja käitlemine aitab säästa loodusvarasid ning tagada, et käitlemine toimib inimtervise ja keskkonnale ohult. Lisateave selle kohta, kuhu saate üliiseseisustada seadmed käitlemiseks või, saate saada kohalikul omavalitsusel, ettenahuld üliiseseisustuspunkti või kauplusele, kust te seadme ostsite.

Hävitettävien laitteiden käsittely kotitalouksissa Euroopan unionin alueella

Tämä kaetun symbolin tarkoitus on tukea valmistajien ja pakkaajien toimia, jotka osoittavat, että tuote ei saa hävitettävien tavajätteen joukkoon. Käyttäjien velvollisuus on huolehtia siitä, että hävitettävät laitteet käsitellään erikseen sähkö- ja elektronikalaitteiden keräilykeskuksissa. Hävitettävien laitteiden erillinen keräily ja käsittely säästää luonnonvaroja. Näin toimimalla varmistetaan myös, että hävitettävien laitteiden käsittely on ihmisten terveydelle ja ympäristölle turvallista. Lisätietoja siitä, missä voit tuoda hävitettävät laitteet, saat paikalliselta viranomaiselta, jonnekin erikseen osoitetusta keräilykeskuksesta, kaupasta tai muusta toimipisteestä.

Απορριψη άχρηστων συσκευών στην Ευρωπαϊκή Ένωση

Το παρόν σύμβολο στον εξοπλισμό ή στη συσκευασία του υποδηλώνει ότι ο προϊόν αυτό δεν πρέπει να απορριφθεί με άλλα οικιακά απορρίμματα. Αντιθέτως, εφόσον απο είναι να απορριφθεί η άχρηστη συσκευή σε ένα καθορισμένο σημείο συλλογής απορριμμάτων για την ανακύκλωση ηλεκτρικών ή ηλεκτρονικών εξοπλισμών. Η χωριστή συλλογή και ανακύκλωση των άχρηστων συσκευών θα συμβάλει στη διατήρηση των φυσικών πόρων και στη διασφάλιση ότι τα ανακυκλωμένα υλικά είναι πιο καθαρά, ώστε να προστατευτεί η υγεία των ανθρώπων και το περιβάλλον. Για περισσότερες πληροφορίες σχετικά με το πού μπορεί να απορριφθεί η άχρηστη συσκευή για ανακύκλωση, επικοινωνήστε με το κατάστημα αγοράς, αρχίζ ή με το κοινοτικό ή το οποίο αγοράσθηκε το προϊόν.

A hulludeklaratsioonid käsitlemise kohta Euroopa Liidus

Et a sümbol, mis toetab teie tootmis- ja pakendamise tegevust, mis näitab, et see toode ei saa hävitada tavajätmete hulka. Teie lohus on viia tarbeks muundatud seadme selleks ettenahuld elektrilise ja elektroonikaseadmete üliiseseisustamiseks. Üliiseseisustamine seadmete eraldi kogumine ja käitlemine aitab säästa loodusvarasid ning tagada, et käitlemine toimib inimtervise ja keskkonnale ohult. Lisateave selle kohta, kuhu saate üliiseseisustada seadmed käitlemiseks või, saate saada kohalikul omavalitsusel, ettenahuld üliiseseisustuspunkti või kauplusele, kust te seadme ostsite.

Liettuvi atvirkavimas non nederigam lertam Eiropas Savienības privātos mājās

Šis simbols uz ierīci vai tās iepakojuma norāda, ka šis produkts nedrīkst tikt likvidēts kopā ar citiem mājokļa atkritumiem. Jūs esat atbildīgs par atvirkavimas non nederigam, to nododot norādītajā savienības vietā, lai liktu vietā nederīgā elektriskā un elektroniskā aparātu. Speciāla nederīgā ierīču savienāšana un atvirkavimas prātrāde palīdz tādā veidā resursus un nodrošina tūdu atvirkavimas, kas sargā cilvēku veselību un apkārtni vidi. Lai iegūtu papildu informāciju par to, kur atvirkavimas prātrādi var nodot nederīgā ierīču, lūdz, sazināties ar vietējo pašvaldību, mājasapkalpošanas pakalpojuma uzdevinātāju vai ar veikali.

Europas Savienības vartotāji ir privāti namu ūķu atliekomas ierogus iemetimas

Šis simbols ar produktu arba jo pakojuma etiķetē, kas norāda, ka šis produkts nedrīkst tikt likts kopā ar citiem mājokļa atkritumiem. Jūs esat atbildīgs par atvirkavimas non nederigam, to nododot norādītajā savienības vietā, lai liktu vietā nederīgā elektriskā un elektroniskā aparātu. Speciāla nederīgā ierīču savienāšana un atvirkavimas prātrāde palīdz tādā veidā resursus un nodrošina tūdu atvirkavimas, kas sargā cilvēku veselību un apkārtni vidi. Lai iegūtu papildu informāciju par to, kur atvirkavimas prātrādi var nodot nederīgā ierīču, lūdz, sazināties ar vietējo pašvaldību, mājasapkalpošanas pakalpojuma uzdevinātāju vai ar veikali.

Uytizovtā zūtēgo spērtē pztēz utytkovkōm domovoh v Unii Europeiskij

Simbol na uzvieszēgo na produkcije lub opakovanju označuje, že tego produktu nie należy wyrzucać razem z innymi odpadkami domowymi. Użytkownik jest odpowiedzialny za dostarczenie zużytego sprzętu do wyznaczonego punktu gromadzenia zużytych urządzeń elektrycznych i elektronicznych. Oddzielne zgromadzenie i recykling tego typu odpadów przyczynia się do oszczędności zasobów naturalnych i gwarantuje, że recykling jest bezpieczny dla zdrowia i środowiska naturalnego. Więcej informacji na temat sposobu utylizacji zużytych urządzeń można uzyskać u odpowiednich władz lokalnych, w przedsiębiorstwach zajmujących się usuwaniem odpadów lub w miejscu zakupu produktu.

Descarte de equipamentos por usuários em residências da União Europeia

Este símbolo no produto ou no embalagem indica que o produto não pode ser descartado junto com o lixo doméstico. No entanto, é sua responsabilidade levar os equipamentos a serem descartados a um ponto de coleta designado para o reciclagem de equipamentos eletro-eletrônicos. A coleta separada e o reciclagem dos equipamentos no momento do descarte ajudam na conservação dos recursos naturais e garantem que os equipamentos serão reciclados de forma a proteger a saúde das pessoas e o meio ambiente. Para obter mais informações sobre onde descartar equipamentos para reciclagem, entre em contato com o escritório local de sua cidade, o serviço de limpeza pública de seu bairro ou o loja em que adquiriu o produto.

Postup používateľov v krajínach Európskej únie pri vyhazovaní zariadenia v domácom používaní do odpadu

Toto znamo na produkte alebo na jeho obale označuje, že zariadenie by nelyhoto s ostatnými domáckimi odpadmi. Namiesto toho máte povinnos odvážda toto zariadenie na zbernom mieste, kde sa zabezpečuje recyklácia elektrických a elektronických zariadení. Separovány zber a recyklácia zariadenia urchéno na odpad pomáha chráni životné zrodie a zabezpečuje taký spôsob recyklácie, ktorý bude chráni ľudské zdravie a životné prostredie. Ďalšie informácie o separovaní zberu a recyklácii získate na miestnom obecnom úrade, vo firme zabezpečujúcej zber vášho komunálneho odpadu alebo v predajni, kde ste produkt kúpili.

Ravnene z odpadno opremo v gospodinjstvih znotraj Evropske unije

Ta značka na izdelku ali embalaži označuje, da ta izdelek ne smete z drugimi gospodinjstvenimi odpadki. Odgovorno je odstraniti ta izdelki na določenem zbirnem mestu za recikliranje odpadne električne in elektronske opreme. Z ločenim zbiranjem in recikliranjem odpadne opreme ob odložitvi boste pomagali ohraniti naravno vire in zagotovili, da bo odpadno opremo reciklirano tako, da se varuje zdravje ljudi in okolje. Več informacij o mestih, kjer lahko oddate odpadno opremo za recikliranje, lahko dobite na občini, v komunalnem podjetju ali trgovini, kjer ste izdelek kupili.

Kassering av förbrukningsmaterial, för hem- och privatvårdare i EU

Produkt eller förbrukningsmaterial med den här symbolen får inte kasseras med vanlig hushållsavfall. I stället har du ansvar för att produkten kasseras till ett inbörtnings- eller återvinningstjänststation för hantering av el och elektronisk utrustning. Genom att kassera produkterna till återvinning hjälper du till att bevara våra gemensamma naturresurser. Dessutom skyddas både människor och miljön när produkter återvinns på rätt sätt. Kontakta myndigheter, sophanteringsföretag eller butikken där varan köptes kan ge mer information om var du lämnar kasserade produkter för återvinning.

Chemical Substances

HP is committed to providing our customers with information about the chemical substances in our products as needed to comply with legal requirements such as REACH (*Regulation EC No 1907/2006 of the European Parliament and the Council*). A chemical information report for this product can be found at: www.hp.com/go/reach.

Technical information

Regulatory notices

The HP Photosmart meets product requirements from regulatory agencies in your country/region.

This section contains the following topics:

- [Regulatory model identification number](#)
- [FCC statement](#)
- [VCCI \(Class B\) compliance statement for users in Japan](#)
- [Notice to users in Japan about the power cord](#)
- [Notice to users in Korea](#)
- [HP Photosmart D110 series declaration of conformity](#)

Regulatory model identification number

For regulatory identification purposes, your product is assigned a Regulatory Model Number. The Regulatory Model Number for your product is SNPRH-0901. This regulatory number should not be confused with the marketing name (HP Photosmart D110 series, etc.) or product numbers (Q8380A, etc.).

FCC statement

FCC statement

The United States Federal Communications Commission (in 47 CFR 15.105) has specified that the following notice be brought to the attention of users of this product.

This equipment has been tested and found to comply with the limits for a Class B digital device, pursuant to Part 15 of the FCC Rules. These limits are designed to provide reasonable protection against harmful interference in a residential installation. This equipment generates, uses and can radiate radio frequency energy and, if not installed and used in accordance with the instructions, may cause harmful interference to radio communications. However, there is no guarantee that interference will not occur in a particular installation. If this equipment does cause harmful interference to radio or television reception, which can be determined by turning the equipment off and on, the user is encouraged to try to correct the interference by one or more of the following measures:

- Reorient the receiving antenna.
- Increase the separation between the equipment and the receiver.
- Connect the equipment into an outlet on a circuit different from that to which the receiver is connected.
- Consult the dealer or an experienced radio/TV technician for help.

For further information, contact:

Manager of Corporate Product Regulations
Hewlett-Packard Company
3000 Hanover Street
Palo Alto, Ca 94304
(650) 857-1501

Modifications (part 15.21)

The FCC requires the user to be notified that any changes or modifications made to this device that are not expressly approved by HP may void the user's authority to operate the equipment.

This device complies with Part 15 of the FCC Rules. Operation is subject to the following two conditions: (1) this device may not cause harmful interference, and (2) this device must accept any interference received, including interference that may cause undesired operation.

VCCI (Class B) compliance statement for users in Japan

この装置は、クラスB情報技術装置です。この装置は、家庭環境で使用することを目的としていますが、この装置がラジオやテレビジョン受信機に近接して使用されると、受信障害を引き起こすことがあります。取扱説明書に従って正しい取り扱いをして下さい。

VCCI-B

Notice to users in Japan about the power cord

製品には、同梱された電源コードをお使い下さい。
同梱された電源コードは、他の製品では使用出来ません。

Notice to users in Korea

B 급 기기 (가정용 방송통신기기)	이 기기는 가정용(B급)으로 전자파적합등록을 한 기기로서 주로 가정에서 사용하는 것을 목적으로 하며, 모든 지역에서 사용할 수 있습니다.
------------------------	--

HP Photosmart D110 series declaration of conformity



DECLARATION OF CONFORMITY

according to ISO/IEC 17050-1 and EN 17050-1

DoC #: SNPRH-0901 Rev A

Supplier's Name: Hewlett-Packard Company
Supplier's Address: 20, Jia Feng Road Waigaoqiao Free Trade Zone Pudong, Shanghai
, PRC 200131
declares, that the product

Product Name and Model: HP Photosmart D110 series
Regulatory Model Number: ¹⁾ SNPRH-0901
Radio Module: SDGOB-0892
Power Adapter: 0957-2269
Product Options: All

conforms to the following Product Specifications and Regulations:**EMC:**

FCC CFR 47 Part 15 Class B / ICES-003, Issue 4 Class B

Safety:EN 60950-1:2001+A11:2004 / IEC 60950-1:2001
EN 60825-1 1994+A1:2002+A2:2001
IEC 62311:2007 / EN 62311:2008**Telecom:**EN 300 328 V1.7.1:2006
EN 301 489-1 V1.8.1:2008 / EN 301 489-17 V1.3.2:2008

This device complies with part 15 of the FCC Rules. Operation is subject to the following two conditions:
(1) This device may not cause harmful interference, and (2) this device must accept any interference received,
including interference that may cause undesired operation.

Additional Information:

- 1) This product is assigned a Regulatory Model Number which stays with the regulatory aspects of the design. The Regulatory Model Number is the main product identifier in the regulatory documentation and test reports, this number should not be confused with the marketing name or the product numbers.

18th Sep 2009

Hu Jintao

ICS Product Hardware Quality Engineering Manager

Local contact for regulatory topics only:

EMEA: Hewlett-Packard GmbH, HQ-TRE, Herrenberger Strasse 140, 71034 Boeblingen, Germany
U.S.: Hewlett-Packard, 3000 Hanover St., Palo Alto 94304, U.S.A. 650-857-1501

www.hp.com/go/certificates

Regulatory wireless statements

This section contains the following regulatory information pertaining to wireless products:

- [Exposure to radio frequency radiation](#)
- [Notice to users in Brazil](#)
- [Notice to users in Canada](#)
- [Notice to users in Taiwan](#)
- [European Union regulatory notice](#)

Exposure to radio frequency radiation

Exposure to radio frequency radiation



Caution The radiated output power of this device is far below the FCC radio frequency exposure limits. Nevertheless, the device shall be used in such a manner that the potential for human contact during normal operation is minimized. This product and any attached external antenna, if supported, shall be placed in such a manner to minimize the potential for human contact during normal operation. In order to avoid the possibility of exceeding the FCC radio frequency exposure limits, human proximity to the antenna shall not be less than 20 cm (8 inches) during normal operation.

Notice to users in Brazil

Aviso aos usuários no Brasil

Este equipamento opera em caráter secundário, isto é, não tem direito à proteção contra interferência prejudicial, mesmo de estações do mesmo tipo, e não pode causar interferência a sistemas operando em caráter primário. (Res. ANATEL 282/2001).

Notice to users in Canada

Notice to users in Canada/Note à l'attention des utilisateurs canadiens

For Indoor Use. This digital apparatus does not exceed the Class B limits for radio noise emissions from the digital apparatus set out in the Radio Interference Regulations of the Canadian Department of Communications. The internal wireless radio complies with RSS 210 and RSS GEN of Industry Canada.

Utiliser à l'intérieur. Le présent appareil numérique n'émet pas de bruit radioélectrique dépassant les limites applicables aux appareils numériques de la classe B prescrites dans le Règlement sur le brouillage radioélectrique édicté par le ministère des Communications du Canada. Le composant RF interne est conforme à la norme RSS-210 and RSS GEN d'Industrie Canada.

Notice to users in Taiwan

低功率電波輻射性電機管理辦法

第十二條

經型式認證合格之低功率射頻電機，非經許可，公司、商號或使用者均不得擅自變更頻率、加大功率或變更設計之特性及功能。

第十四條

低功率射頻電機之使用不得影響飛航安全及干擾合法通信；經發現有干擾現象時，應立即停用，並改善至無干擾時方得繼續使用。

前項合法通信，指依電信法規定作業之無線電通信。低功率射頻電機須忍受合法通信或工業、科學及醫藥用電波輻射性電機設備之干擾。

European Union Regulatory Notice

Products bearing the CE marking comply with the following EU Directives:

- Low Voltage Directive 2006/95/EC
- EMC Directive 2004/108/EC

CE compliance of this product is valid only if powered with the correct CE-marked AC adapter provided by HP.

If this product has telecommunications functionality, it also complies with the essential requirements of the following EU Directive:

- R&TTE Directive 1999/5/EC

Compliance with these directives implies conformity to harmonized European standards (European Norms) that are listed in the EU Declaration of Conformity issued by HP for this product or product family. This compliance is indicated by the following conformity marking placed on the product.



The wireless telecommunications functionality of this product may be used in the following EU and EFTA countries:

Austria, Belgium, Bulgaria, Cyprus, Czech Republic, Denmark, Estonia, Finland, France, Germany, Greece, Hungary, Iceland, Ireland, Italy, Latvia, Liechtenstein, Lithuania, Luxembourg, Malta, Netherlands, Norway, Poland, Portugal, Romania, Slovak Republic, Slovenia, Spain, Sweden, Switzerland and United Kingdom.

Products with 2.4-GHz wireless LAN devices

France

For 2.4 GHz Wireless LAN operation of this product certain restrictions apply: This product may be used indoor for the entire 2400-2483.5 MHz frequency band (channels 1-13). For outdoor use, only 2400-2454 MHz frequency band (channels 1-9) may be used. For the latest requirements, see <http://www.art-telecom.fr>.

Italy

License required for use. Verify with your dealer or directly with the General Direction for Frequency Planning and Management (Direzione Generale Pianificazione e Gestione Frequenze).

Index

Symbols/Numerics

10 x 15 cm photo paper
specifications 37

B

buttons, control panel 6

C

control panel
 buttons 6
 features 6
copy
 specifications 38
customer support
 warranty 35

E

encryption
 WEP key 28
envelopes
 specifications 37
environment
 Environmental product
 stewardship program 38
 environmental
 specifications 37

I

ink-backup mode 22
interface card 25, 26

L

labels
 specifications 37
legal paper
 specifications 37
letter paper
 specifications 37

N

network
 interface card 25, 26
 security 28

P

paper
 specifications 37
phone support period
 period for support 35
photo paper
 specifications 37
print
 specifications 38
printer found screen,
 Windows 29
printing
 with one ink cartridge 22

R

recycle
 ink cartridges 40
regulatory notices
 regulatory model
 identification number 42
 wireless statements 45

S

scan
 scan specifications 38
security
 network, WEP key 28, 29
 troubleshoot 28
system requirements 37

T

technical information
 copy specifications 38
 environmental
 specifications 37
 paper specifications 37
 print specifications 38
 scan specifications 38
 system requirements 37
transparencies
 specifications 37

W

warranty 35
WEP key, setup 28