

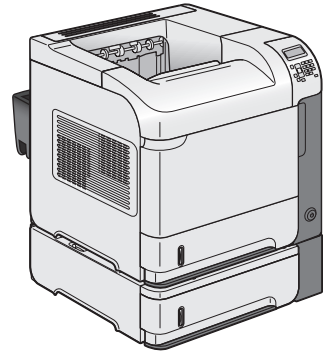

LASERJET ENTERPRISE M601, M602, M603

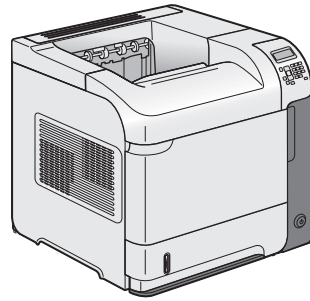
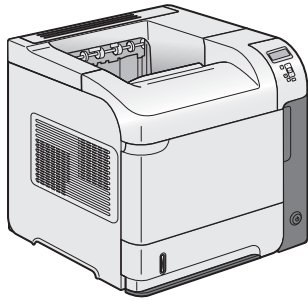

- EN Installation Guide
- ZHCN 安装指南
- ID Panduan Pemasangan
- JA 装着ガイド
- KO 설치 설명서
- TH คู่มือการติดตั้ง
- ZHTW 安裝指南
- VI Hướng dẫn cài đặt

1

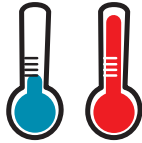

10° - 32.5°C
(50° - 91°F)



EN Select a sturdy, well-ventilated, dust-free area, away from direct sunlight to position the product.

ZHCN 选择一个稳固、通风良好、无尘且远离直射日光的区域放置产品。

ID Untuk meletakkan produk, pilih tempat yang kokoh, berventilasi baik, bebas debu, dan jauh dari sinar matahari langsung.

JA 製品の設置場所には、直射日光を避けて、通気がよく埃の少ない、しっかりした場所を選びます。

KO 직사광선을 피하여 바닥이 단단하고 환기가 잘 되며 먼지가 없는 장소를 선택하여 제품을 내려 놓습니다.

TH เลือกวางเครื่องพิมพ์ในบริเวณที่แข็งแรง อากาศถ่ายเทสะดวก และไม่ถูกแสงแดดโดยตรง

ZHTW 請選擇一個平整穩固、通風良好且沒有灰塵的區域放置本產品，並避免陽光直射。

VI Chọn nơi vững chắc, được thông hơi tốt, không có bụi bặm, không tiếp xúc trực tiếp với ánh sáng mặt trời để đặt sản phẩm.

2

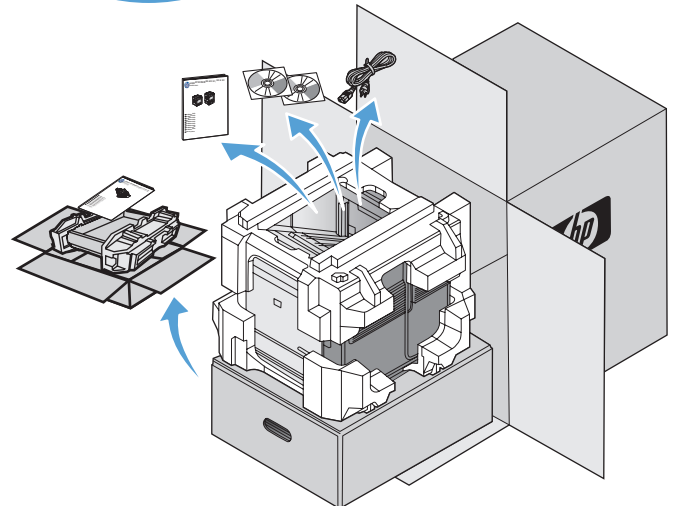
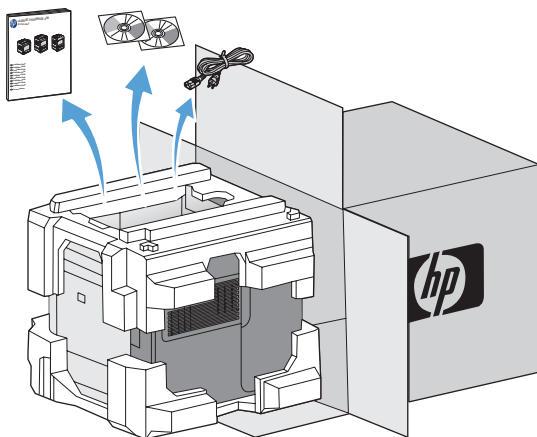
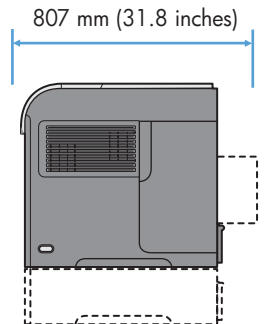
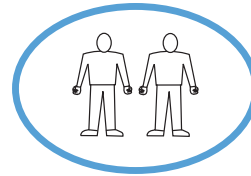
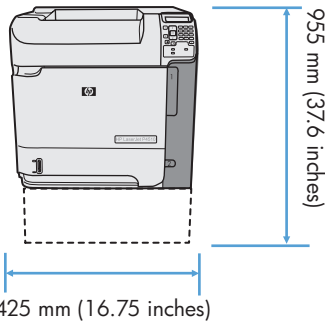
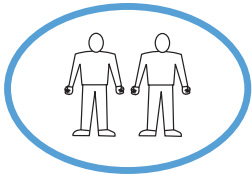

3

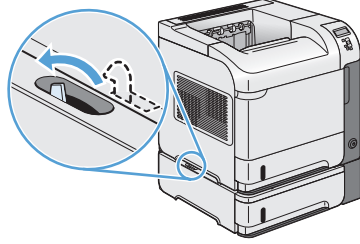
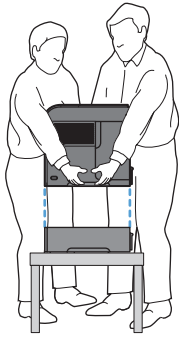

4

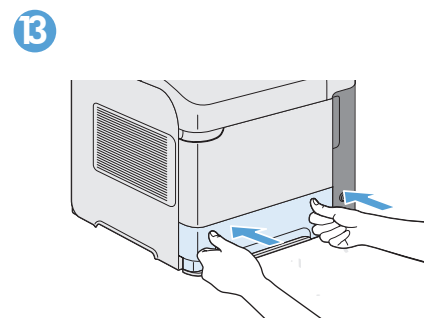
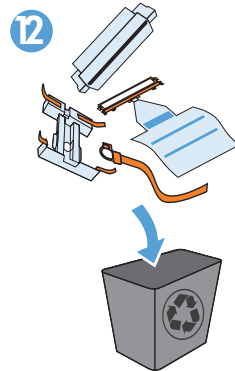
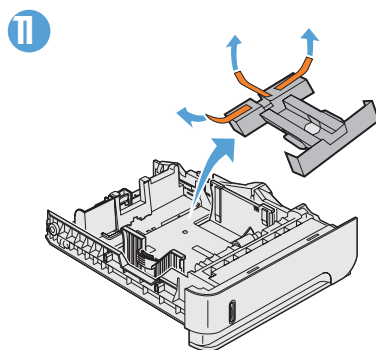
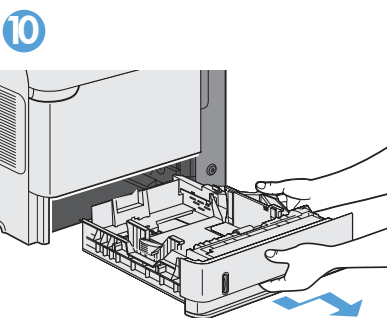
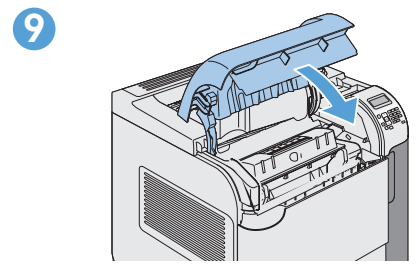
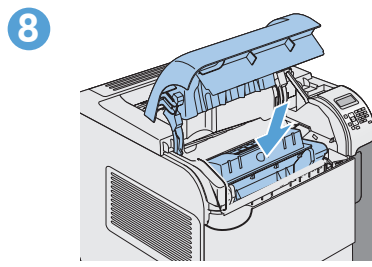
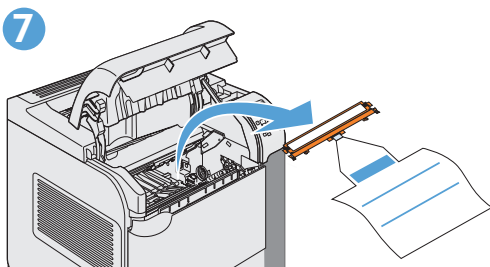
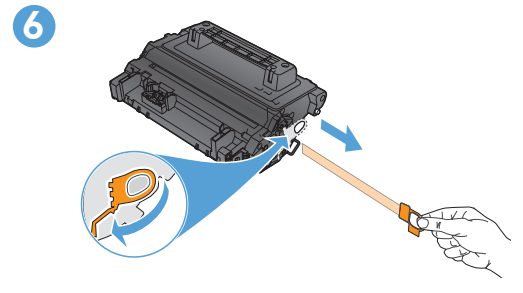
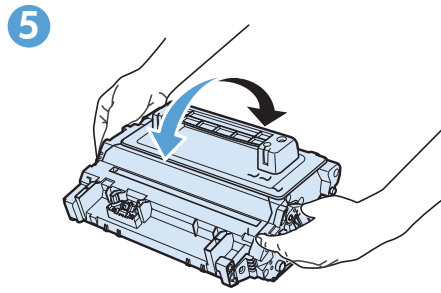
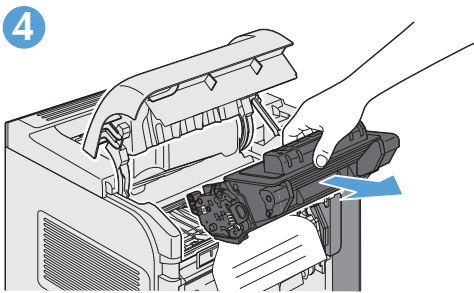
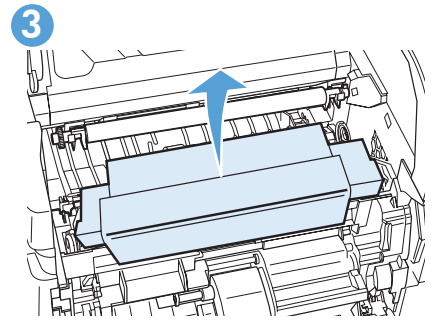
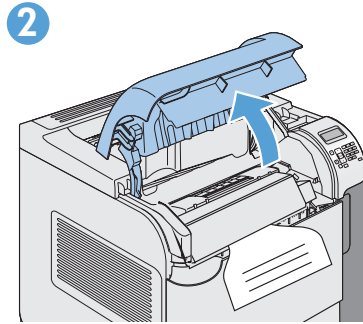
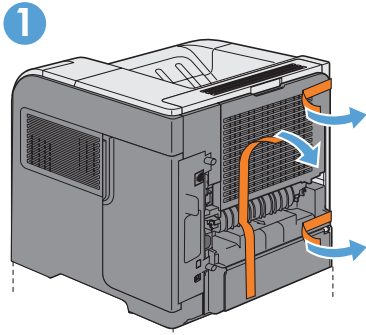

5 USB

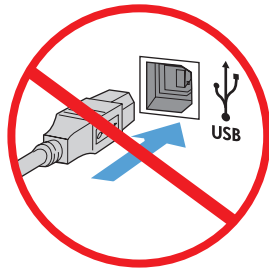

EN **Caution!** Do not connect the USB cable until prompted during software installation (CD).

ZHCN **注意!** 在软件安装 (CD) 期间出现提示后再连接 USB 电缆。

ID **Perhatian!** Jangan sambungkan kabel USB hingga diminta saat penginstalan perangkat lunak (CD) berlangsung.

JA **注意!** ソフトウェアのインストール (CD) 中は、画面に指示が表示されるまで USB ケーブルを接続しないでください。

KO **주의!** 소프트웨어를 설치(CD)하는 동안 메시지가 나타날 때까지 USB 케이블을 연결하지 마십시오.

TH **โปรดระวัง** อย่าต่อสาย USB จนกว่าจะมีข้อความแจ้งในระหว่างการติดตั้งซอฟต์แวร์ (CD)

ZHTW **注意!** 在軟體安裝 (CD) 期間，請等到出現提示後，再連接 USB 纜線。

VI **Cẩn thận!** Không cắm cáp USB cho tới khi được nhắc trong khi cài đặt phần mềm (CD).

6

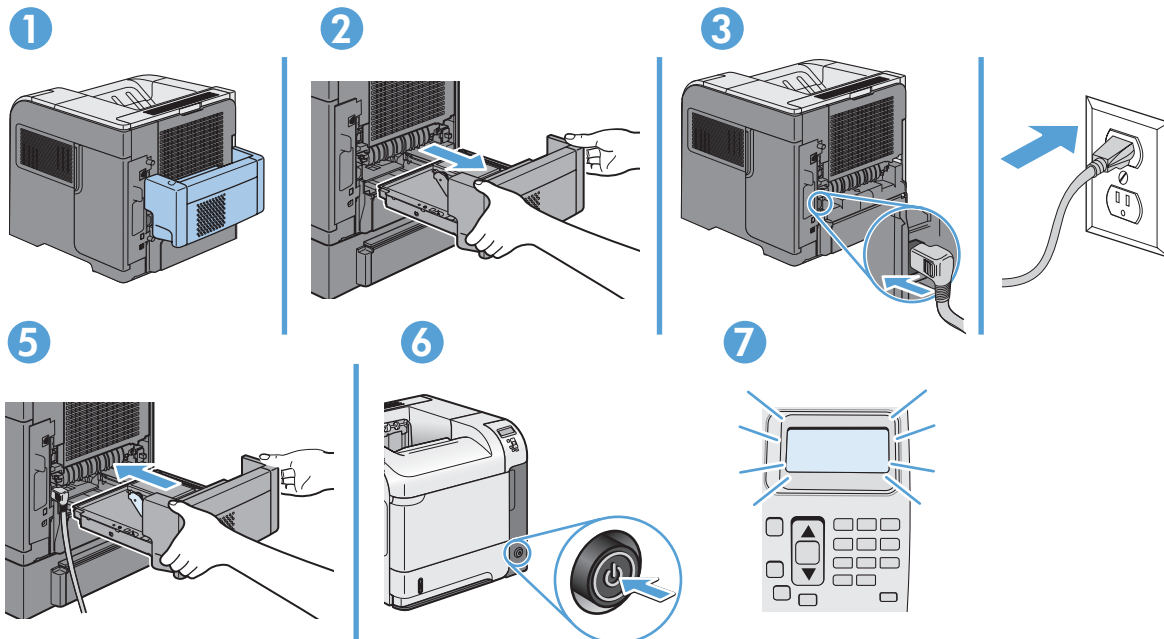
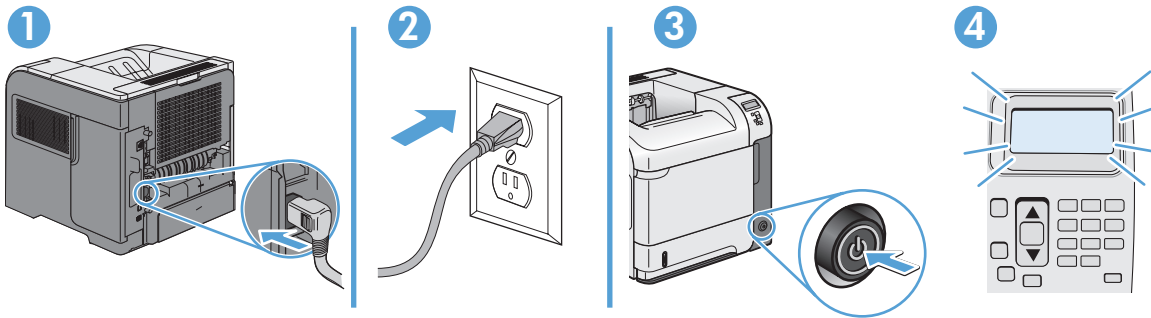

EN Connect the power cord between the product and a grounded ac outlet. Turn on the product. On the control panel, set the language and the date/time.
Caution: Make sure your power source is adequate for the product voltage rating. The voltage rating is on the product label. The product uses either 100-127 Vac or 220-240 Vac and 50/60 Hz. To prevent damage to the product, use only the power cord that is provided with the product.

ZHCN 使用电源线将产品连接到接地交流电源插座上。打开产品电源。在控制面板上设置语言和日期/时间。
注意：确保电源符合产品的额定电压要求。产品标签上注明了额定电压。本产品使用 100-127 伏（交流）或 220-240 伏（交流），50/60 赫兹的电压。为防止损坏产品，请仅使用产品附带的电源线。

ID Sambungkan kabel daya antara produk dan stopkontak AC yang diarde. Hidupkan produk. Pada panel kontrol, tetapkan bahasa dan tanggal/waktu.
Perhatian: Pastikan catu daya Anda memadai untuk tingkat tegangan produk. Tingkat tegangan tercantum pada label produk. Produk ini menggunakan 100-127 Vac atau 220-240 Vac dan 50/60 Hz. Untuk mencegah kerusakan produk, gunakan hanya kabel daya yang disertakan bersama produk.

JA 電源コードで、プリンタをアース付 AC コンセントに接続します。プリンタの電源を入れます。コントロール パネルで、言語および日時を設定します。
注意：使用する電源が、プリンタの定格電圧に適しているか確認してください。定格電圧は製品ラベルに記載されています。プリンタで使用する電圧は 100 ~ 127 VAC または 220 ~ 240 VAC、周波数は 50/60 Hz です。プリンタの損傷を防ぐため、プリンタに付属の電源コード以外は使用しないでください。

KO 전원 코드를 제품과 접지된 AC 콘센트 사이에 연결합니다. 제품을 켭니다. 제어판에서 언어 및 날짜/시간을 설정합니다.
주의: 콘센트의 전압이 제품 전압에 맞는지 확인합니다. 전압은 제품 레이블에 나와 있습니다. 제품은 100-127V 또는 220-240V 및 50/60Hz를 사용합니다. 제품의 손상을 방지하려면 제품과 함께 제공된 전원 코드만 사용하십시오.

TH ต่อสายไฟจากเครื่องพิมพ์เข้ากับเต้าเสียบที่ใช้ไฟฟ้ากระแสสลับและมีการต่อสายดิน เปิดเครื่องพิมพ์ ตั้งภาษาและวันที่และเวลาบนแผงควบคุม
ข้อควรระวัง: ตรวจสอบให้แน่ใจว่าแหล่งจ่ายไฟของคุณเพียงพอกับแรงดันไฟฟ้าของเครื่องพิมพ์ แรงดันไฟฟ้าอยู่บนฉลากของเครื่องพิมพ์ เครื่องพิมพ์อาจใช้ 100-127 Vac หรือ 220-240 Vac และ 50/60 Hz เพื่อป้องกันไม่ให้เครื่องพิมพ์เสียหาย โปรดใช้สายไฟที่มาพร้อมกับเครื่องพิมพ์เท่านั้น

ZHTW 使用電源線連接產品及接地的 AC 插座。開啟本產品電源。在控制面板上設定語言與日期/時間。
注意：確定電源符合產品的額定電壓。額定電壓標示在產品標籤上。產品使用 100-127 Vac 或 220-240 Vac 其中之一，50/60 Hz。為了避免產品損壞，請僅使用產品隨附的電源線。

VI Kết nối dây nguồn giữa sản phẩm và ổ điện ac có tiếp đất. Bật sản phẩm. Trên bảng điều khiển, đặt ngôn ngữ và ngày/giờ.
Cẩn thận: Đảm bảo rằng nguồn điện của bạn thích hợp với định mức điện áp của sản phẩm. Định mức điện áp được ghi trên nhãn sản phẩm. Sản phẩm sử dụng điện áp 100-127 Vac hoặc 220-240 Vac và 50/60 Hz. Để tránh làm hỏng sản phẩm, chỉ sử dụng dây điện được cung cấp cùng sản phẩm.

7

1

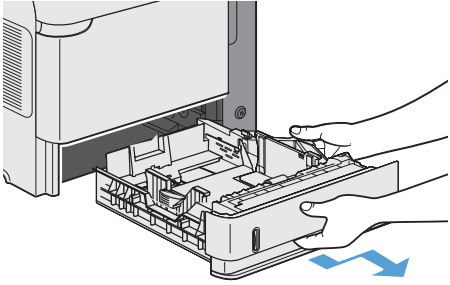

2

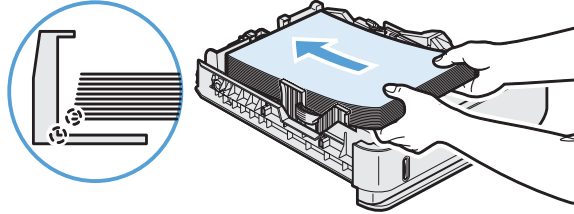

3

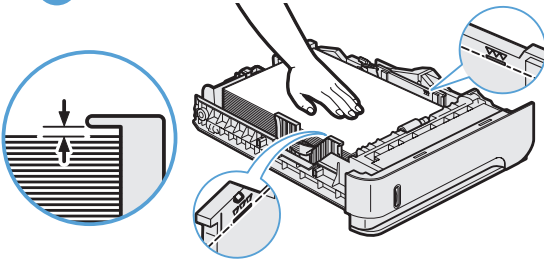

4

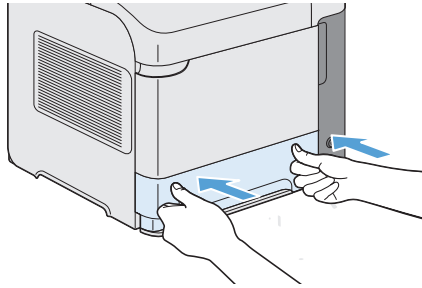

5

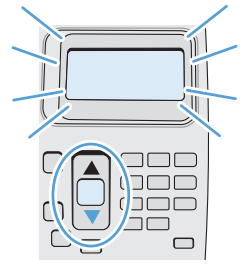

8

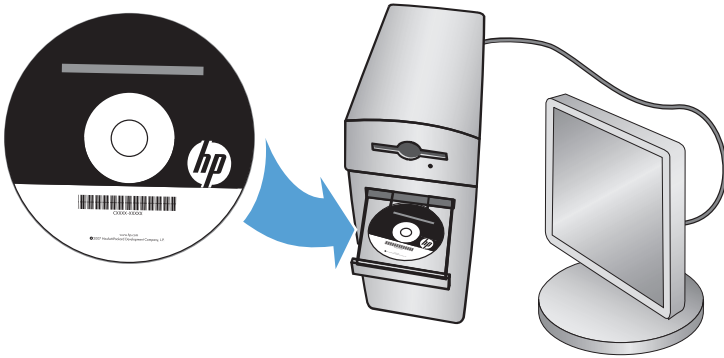

- EN** For more product and problem-solving information go to the User Guide or www.hp.com/support/lj600QSeries
- ZHCN** 有关产品及问题解决方面的更多信息，请参阅《用户指南》或者访问 www.hp.com/support/lj600QSeries
- ID** Untuk informasi produk dan cara mengatasi masalah lainnya, lihat Panduan Pengguna atau kunjungi www.hp.com/support/lj600QSeries
- JA** 製品および問題の解決についての詳細は、ユーザーガイドまたは以下を参照してください。
www.hp.com/support/lj600QSeries
- KO** 제품 및 문제 해결에 대한 자세한 내용은 사용 설명서 또는 다음을 참조하십시오.
www.hp.com/support/lj600QSeries
- TH** สำหรับข้อมูลเพิ่มเติมของเครื่องพิมพ์และการแก้ไขปัญหาโปรดดูคู่มือผู้ใช้ หรือ www.hp.com/support/lj600QSeries
- ZHTW** 如需有關產品與問題解決的詳細資訊，請參閱《使用指南》或造訪 www.hp.com/support/lj600QSeries
- VI** Để biết thêm thông tin về sản phẩm và cách khắc phục sự cố, hãy truy cập Hướng dẫn sử dụng hoặc www.hp.com/support/lj600QSeries



© 2011 Copyright Hewlett-Packard Development Company, L.P.

Reproduction, adaptation or translation without prior written permission is prohibited, except as allowed under the copyright laws.

The information contained herein is subject to change without notice.

The only warranties for HP products and services are set forth in the express warranty statements accompanying such products and services. Nothing herein should be construed as constituting an additional warranty. HP shall not be liable for technical or editorial errors or omissions contained herein.

Part number: CE988-90961

Edition 1, 9/2011

FCC Regulations

This equipment has been tested and found to comply with the limits for a Class B digital device, pursuant to Part 15 of the FCC rules. These limits are designed to provide reasonable protection against harmful interference in a residential installation. This equipment generates, uses, and can radiate radio-frequency energy. If this equipment is not installed and used in accordance with the instructions, it may cause harmful interference to radio communications. However, there is no guarantee that interference will not occur in a particular installation. If this equipment does cause harmful interference to radio or television reception, which can be determined by turning the equipment off and on, correct the interference by one or more of the following measures:

- Reorient or relocate the receiving antenna.
- Increase separation between equipment and receiver.
- Connect equipment to an outlet on a circuit different from that to which the receiver is located.
- Consult your dealer or an experienced radio/TV technician.

Any changes or modifications to the product that are not expressly approved by HP could void the user's authority to operate this equipment. Use of a shielded interface cable is required to comply with the Class B limits of Part 15 of FCC rules. For more regulatory information, see the electronic user guide. Hewlett-Packard shall not be liable for any direct, indirect, incidental, consequential, or other damage alleged in connection with the furnishing or use of this information.

Trademark Credits

Windows® is a U.S. registered trademark of Microsoft Corporation.

© 2011 Copyright Hewlett-Packard Development Company, L.P.

未经事先书面许可，严禁进行任何形式的复制、改编或翻译，除非版权法另有规定。

本文档中包含的信息如有更改，恕不另行通知。

随 HP 产品和服务附带的明确保修声明中阐明了此类产品和服务的全部保修情况。此处内容不代表任何额外保修。HP 公司对此处任何技术性编辑性的错误或遗漏概不负责。

部件号：CE988-90961

2011 年 9 月第 1 版

FCC 规则

本设备已经过测试，确认符合 FCC 规则第 15 部分有关 B 类数字设备的限制规定。在住宅区安装时，这些限制为防止有害干扰提供了合理保护。本设备可以产生、利用并发射无线射频能量。如果不按说明中的要求安装和使用本设备，有可能对无线电通信产生有害干扰。但也不能保证在特定的安装中不会产生干扰。如果本设备确实对无线电或电视接收造成干扰（可以通过开关设备来确定），可以通过以下一种或多种措施排除干扰：

- 重新调整接收天线的方向或位置。
- 增加设备和接收器之间的距离。
- 将本设备电源插座与接收器电源的插座设在不同的电路上。
- 咨询代理商或经验丰富的无线电 / 电视技术人员。

未经 HP 书面批准而对产品进行任何更改或修改都将导致用户不能操作此设备。使用屏蔽的接口电缆时必须遵循 FCC 规则第 15 部分中的 B 类限制。有关更多管制信息，请参阅电子版《用户指南》。对于由本信息的提供或使用所引起的任何直接、间接、偶然、继发性或其它损失，Hewlett-Packard 概不负责。

商标说明

Windows® 是 Microsoft Corporation 在美国的注册商标。



CE988-90961

