



HP Z210 Workstation Series

User Guide

Copyright Information

First Edition: February 2011

Part number: 634377-001

Warranty

Hewlett-Packard Company shall not be liable for technical or editorial errors or omissions contained herein or for incidental or consequential damages in connection with the furnishing, performance, or use of this material. The information in this document is provided "as is" without warranty of any kind, including, but not limited to, the implied warranties of merchantability and fitness for a particular purpose, and is subject to change without notice. The warranties for HP products are set forth in the express limited warranty statements accompanying such products.

Nothing herein should be construed as constituting an additional warranty.

This document contains proprietary information that is protected by copyright. No part of this document may be photocopied, reproduced, or translated to another language without the prior written consent of Hewlett-Packard Company.

Trademark Credits

The HP Invent logo is a trademark of Hewlett-Packard Company in the U.S. and other countries.

Microsoft and Windows are U.S. registered trademarks of Microsoft Corporation.

Intel is a trademark of Intel Corporation in the U.S. and other countries and are used under license.

Acrobat is a trademark of Adobe Systems Incorporated.

ENERGY STAR is a U.S. registered mark of the United States Environmental Protection Agency.

About this guide

This guide provides setup and troubleshooting information for HP Z210 Workstations. It includes these topics:

Guide topics

[Locating HP resources on page 1](#)

[Workstation components on page 7](#)

[Setting up the workstation on page 14](#)

[Setting up the operating system on page 25](#)

[Restoring the operating system on page 31](#)

[Preparing for component installation on page 34](#)

[Installing memory on page 38](#)

[Installing PCI/PCIe devices on page 41](#)

[Installing hard disk drives on page 44](#)

[Installing optical disk drives on page 53](#)

 **TIP:** If you do not find what you are looking for in this guide for your HP Z210 workstation, refer to the workstation *Maintenance and Service Guide* on the Web at http://www.hp.com/support/workstation_manuals/, or see <http://www.hp.com/go/workstations> for additional information about your workstation.

Table of contents

1	Locating HP resources	1
	Product information	2
	Product support	3
	Product documentation	4
	Product diagnostics	5
	Product updates	6
2	Workstation components	7
	HP Z210 CMT Workstation components	7
	HP Z210 CMT Workstation chassis components	8
	HP Z210 CMT Workstation front panel components	9
	HP Z210 CMT Workstation rear panel components	10
	HP Z210 SFF Workstation components	11
	HP Z210 SFF Workstation chassis components	11
	HP Z210 SFF Workstation front panel components	12
	HP Z210 SFF Workstation rear panel components	13
3	Setting up the workstation	14
	Ensuring proper ventilation	14
	Setup procedures	15
	Converting to desktop configuration	17
	Adding monitors	19
	Using workstation integrated graphics	19
	Planning for additional monitors	19
	Finding supported graphics cards	21
	Matching graphics cards to monitor connectors	21
	Identifying monitor connection requirements	22
	Connecting the monitors	23
	Configuring the monitors using Microsoft® operating systems	23
	Using a third-party graphics configuration utility	24
	Customizing the monitor display (Microsoft operating systems only)	24
	Accessibility	24
	Security	24
	Product recycling	24
4	Setting up the operating system	25
	Setting up the Microsoft operating system	26
	Installing or upgrading device drivers	26

Transferring files and settings to your Windows workstation	26
Setting up Red Hat Enterprise Linux	27
Verifying hardware compatibility	27
Installing from RHEL optical media	27
Installing with the HP driver CD	27
Setting up Novell SLED	28
Setting up SLED on preloaded systems	28
Installing from SLED optical media	28
Installing with the HP driver CD	28
Updating the workstation	29
Updating the workstation after first boot	29
Upgrading the BIOS	29
Determining current BIOS	29
Upgrading BIOS	30
Upgrading device drivers	30
5 Restoring the operating system	31
Restore method	31
Ordering backup software	32
Restoring Windows 7	32
Ordering the HP Recovery Manager media	32
Restoring the operating system	32
Restoring Novell SLED	33
Creating restore media	33
6 Preparing for component installation	34
Disassembly and installation preparation	34
Preparing the workstation for component installation	34
7 Installing memory	38
Supported memory configurations	38
Installing a DIMM	39
8 Installing PCI/PCIe devices	41
Expansion card slot identification	41
Power limitations for graphics cards	42
Installing an expansion card	42
9 Installing hard disk drives	44
HDD configuration	44
Installing a hard disk drive	45
Installing an HDD in an HP Z210 CMT Workstation	45

Installing an HDD in an HP Z210 SFF Workstation	47
Installing a secondary HDD or media card reader into a Z210 SFF	51
10 Installing optical disk drives	53
Installing an optical drive in an HP Z210 CMT Workstation	53
Installing an optical drive (mini-tower configuration)	53
Installing an optical drive (desktop configuration)	55
Installing an optical drive in an HP Z210 SFF Workstation	56
Notice for Blu-ray optical drives	59
Blu-ray movie playback	59
Blu-ray movie playback compatibility and update	59
Index	60

1 Locating HP resources

This section provides information on the following HP resources for your workstation:

Topics

[Product information on page 2](#)

- Product data sheets
- HP Cool Tools
- Regulatory information
- Accessories
- System board
- Serial number and Certificate of Authenticity labels

[Product support on page 3](#)

- Additional information
- Technical support
- HP Support Assistant
- Business Support Center
- IT Resource Center
- HP Service Center
- HP Business and IT Services
- Warranty information

[Product documentation on page 4](#)

- User and third-party documentation, and white papers
- Product notifications
- QuickSpecs
- Customer Advisories, Security Bulletins, Notices

[Product diagnostics on page 5](#)

- Diagnostics tools
- Audible beeps and LED code definitions
- Web-based support tools

[Product updates on page 6](#)

- Driver and BIOS updates
 - Operating systems
-

Product information

Table 1-1 Product information

Topic	Location
Product data sheets	See www.hp.com/go/quickspecs .
HP Cool Tools	<p>Most HP Microsoft Windows workstations are preloaded with additional software that is not automatically installed during first boot. Additionally, a number of valuable tools on your workstation are preinstalled that may enhance system performance. To access or learn more about these applications, choose one of the following options:</p> <ul style="list-style-type: none">• Click the HP Cool Tools icon on the desktop, or• Open the HP Cool Tools folder by selecting Start > All Programs > HP Cool Tools. <p>To learn more about these applications, click HP Cool Tools—Learn More.</p> <p>To install or launch the applications, click the appropriate application icon.</p>
Regulatory information	Refer to the <i>Safety & Regulatory Information</i> guide for product Class information. You can also refer to the label on the workstation chassis.
Accessories	For complete and current information on supported accessories and components, see http://www.hp.com/go/workstations .
System board	A diagram of the system board is located on the inside of the side access panel. Also, additional information is located in the <i>Maintenance and Service Guide</i> on the Web at http://www.hp.com/support/workstation_manuals/ .
Serial number and Certificate of Authenticity (COA) labels (if applicable)	Serial number labels are on the top panel, or on the side of the unit at the rear, depending on the workstation model. The COA label is generally located on the top or side panel near the serial number label. Some workstations have this label on the bottom of the unit.
Linux	For information on running Linux on HP workstations, see http://www.hp.com/linux/ .

Product support

Table 1-2 Product support

Topic	Location
Additional information	<p>For online access to technical support information and tools, see http://www.hp.com/go/workstationsupport.</p> <p>Support resources include Web-based troubleshooting tools, technical knowledge databases, driver and patch downloads, online communities, and proactive notification services.</p> <p>The following communication and diagnostic tools are also available:</p> <ul style="list-style-type: none">• Instant Chat• Instant Support• Diagnose Problem <p>Refer to the workstation <i>Maintenance and Service Guide</i> for more information on how to receive support.</p>
Technical support	<p>Before you call technical support, refer to the workstation <i>Maintenance and Service Guide</i> for a listing of information you need to have available before you call.</p> <p>For a listing of all worldwide technical support phone numbers, see http://www.hp.com/support/, select your region, and click Contact HP in the upper-left corner.</p>
HP Support Assistant	<p>HP Support Assistant is an HP application that helps you maintain the performance of your workstation and resolve problems through automated updates and tune-ups, built-in diagnostics, and guided assistance.</p> <p>To access HP Support Assistant, double-click the HP Support Assistant icon on your desktop.</p> <p>NOTE: HP Support Assistant is pre-installed on all HP workstations with Microsoft Windows 7 operating systems. HP Support Assistant is not available on workstations running Linux.</p>
Business Support Center (BSC)	<p>For software/driver downloads, warranty information, single-topic documents, user manuals, or service manuals, see http://www.hp.com/go/bizsupport.</p>
IT Resource Center (ITRC)	<p>See http://www.itrc.hp.com/ for a searchable knowledge base for IT professionals.</p>
HP Business and IT Services.	<p>For business and IT information, see http://www.hp.com/hps/.</p>

Table 1-2 Product support (continued)

Topic	Location
HP Hardware Support Services	For hardware service information, see http://h20219.www2.hp.com/services/us/en/always-on/hardware-support-supporting-information.html?jumpid=reg_R1002_USEN .
Warranty information	<p>To locate base warranty information, see http://www.hp.com/support/warranty-lookuptool.</p> <p>To locate an existing Care Pack, see http://www.hp.com/go/lookuptool.</p> <p>To extend a standard product warranty, see http://h20219.www2.hp.com/services/us/en/warranty/carepack-overview.html?jumpid=hpr_R1002_USEN. HP Care Pack Services offer upgraded service levels to extend and expand a standard product warranty.</p>

Product documentation

Table 1-3 Product documentation

Topic	Location
HP user documentation, white papers, and third-party documentation	For the latest online documentation, see http://www.hp.com/support/workstation_manuals . These include this User Guide and the <i>Maintenance and Service Guide</i> .
Product notifications	<p>Subscriber's Choice is an HP program that allows you to sign up to receive driver and software alerts, proactive change notifications (PCNs), the HP newsletter, customer advisories, and more. Sign up at www.hp.com/united-states/subscribe/gateway/?jumpid=go/subscribe-gate1.</p> <p>Customer advisories and product change notifications are also available on http://www.hp.com/go/bizsupport/.</p>
Workstation technical overview and specifications	The Product Bulletin contains QuickSpecs for HP Workstations. QuickSpecs provide an overall specification review of your product. It includes information about its features including the operating system, power supply, memory, CPU, and many other components of the system. To access the QuickSpecs, see http://www.hp.com/go/productbulletin/ .
Customer Advisories, Security Bulletins, and Notices	<p>To find advisories, bulletins, and notices:</p> <ol style="list-style-type: none"> 1. See http://www.hp.com/go/workstationsupport. 2. Select the desired product. 3. From the Resources section, select See more... 4. Use the scroll bar to select Customer Advisories, Customer Bulletins, or Customer Notices.

Product diagnostics

Table 1-4 Product diagnostics

Topic	Location
Diagnostics tools	The HP Vision Diagnostics utility can be found as a burnable ISO image on the workstation hard disk (under C:\VisionDiagnostics), or can be downloaded from the HP web site. For details on using this utility, refer to the section that covers HP Vision Diagnostics in the workstation <i>Maintenance and Service Guide</i> .
Audible beep and LED code definitions	Refer to the appropriate section of the workstation <i>Maintenance and Service Guide</i> for detailed information about beep and Light Emitting Diode (LED) codes applicable to the workstation.

Product updates

Table 1-5 Product updates

Topic	Location
Driver and BIOS updates	<p>See http://www.hp.com/go/workstation_swdrivers to verify that you have the latest drivers for the workstation.</p> <p>To determine the current workstation BIOS on your workstation, follow these steps during system power up:</p> <ol style="list-style-type: none">1. Power on the workstation, and wait for F10=setup to appear on the lower right corner of the screen.2. Press F10 to enter the F10 Setup utility. The F10 Setup utility displays the computer BIOS version under File > System Information.3. Note the computer BIOS version so that you can compare it with the BIOS versions that appear on the HP website.
Operating systems	<p>For information on operating systems supported on HP workstations, see http://www.hp.com/go/wsos.</p> <p>For information on Windows operating systems, see http://www.microsoft.com/support.</p> <p>For information on Linux operating systems, see http://www.hp.com/linux.</p>

2 Workstation components

This chapter describes workstation components. It includes these topics:

Topics

[HP Z210 CMT Workstation components
on page 7](#)

[HP Z210 SFF Workstation components
on page 11](#)

HP Z210 CMT Workstation components

This section describes the HP Z210 Convertible Mini Tower (CMT) Workstation components, including front and rear panel connectors.

For complete and current information on supported accessories and components for the computer, see <http://partsurfer.hp.com>.

HP Z210 CMT Workstation chassis components

The following figure shows the chassis components of a typical HP Z210 CMT Workstation layout. Drive configurations can vary.

Figure 2-1 HP Z210 CMT Workstation chassis components



Table 2-1 HP Z210 CMT Workstation component descriptions

Item	Description	Item	Description
1	Power supply	8	Memory module (DIMM)
2	Side access panel	9	PCIe card
3	Rear system fan	10	PCI card
4	Optical drive	11	Speaker
5	Processor heatsink	12	Hard disk drive
6	Processor (CPU)	13	Front bezel
7	System board	14	Chassis

HP Z210 CMT Workstation front panel components

The following figure shows the front panel of an HP Z210 CMT Workstation. Drive configurations can vary.

Figure 2-2 HP Z210 Workstation front panel

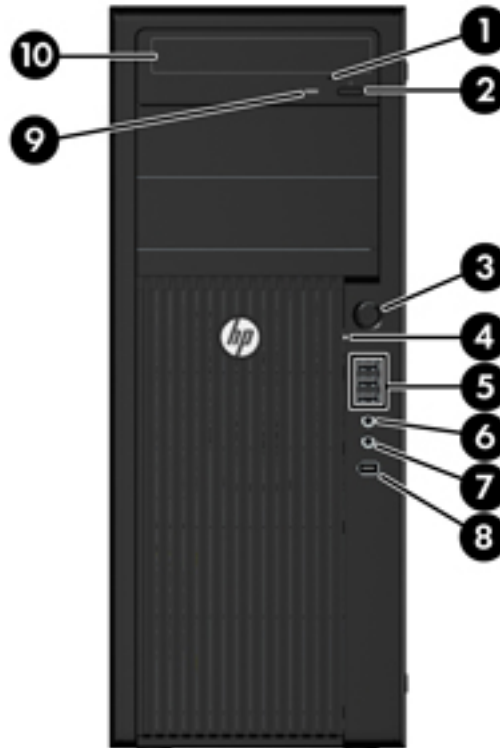







Table 2-2 HP Z210 CMT Workstation front panel connectors

Item	Symbol	Description	Item	Symbol	Description
1		Optical drive manual eject	6		Headphone connector
2		Optical drive eject button	7		Microphone connector
3		Power button	8		1394a connector (optional and plugged unless configured)
4		Hard drive activity light	9		Optical drive activity light
5		USB 2.0 ports (3)	10		Optical drive

HP Z210 CMT Workstation rear panel components





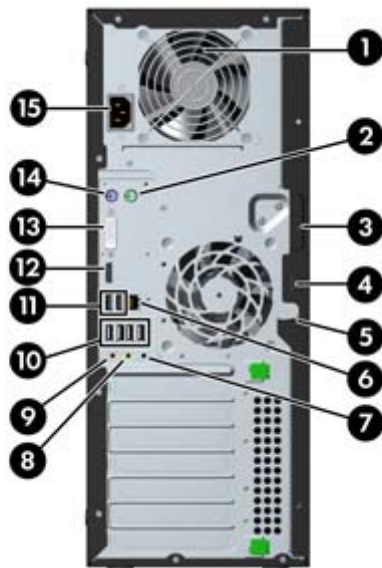





The following figure shows the rear panel of a typical HP Z210 CMT Workstation.

Figure 2-3 HP Z210 CMT Workstation rear panel



NOTE: The labels for the rear panel connectors use industry-standard icons and colors.

Table 2-3 Rear panel components

Item	Symbol	Description	Item	Symbol	Description
1		Power supply fan	8		Audio line-out connector (green)
2		PS/2 mouse connector (green)	9		Microphone connector (pink)
3		Universal chassis clamp opening	10		USB 2.0 ports (4)
4		Cable lock slot	11		USB 2.0 ports (2)
5		Padlock loop	12		Display Port (DP) connector
6		RJ-45 network connector	13		DVI-I connector
7		Audio line-in connector (blue)	14		PS/2 keyboard connector (purple)
			15		Power cord connector

HP Z210 SFF Workstation components

This section describes HP Z210 Small Form Factor (SFF) Workstation components, including front and rear panel connectors.

For complete and current information on supported accessories and components for the computer, see <http://partsurfer.hp.com>.

HP Z210 SFF Workstation chassis components

The following figure shows the chassis components of a typical HP Z210 SFF Workstation layout. Drive configurations can vary.

Figure 2-4 HP Z210 SFF Workstation chassis components

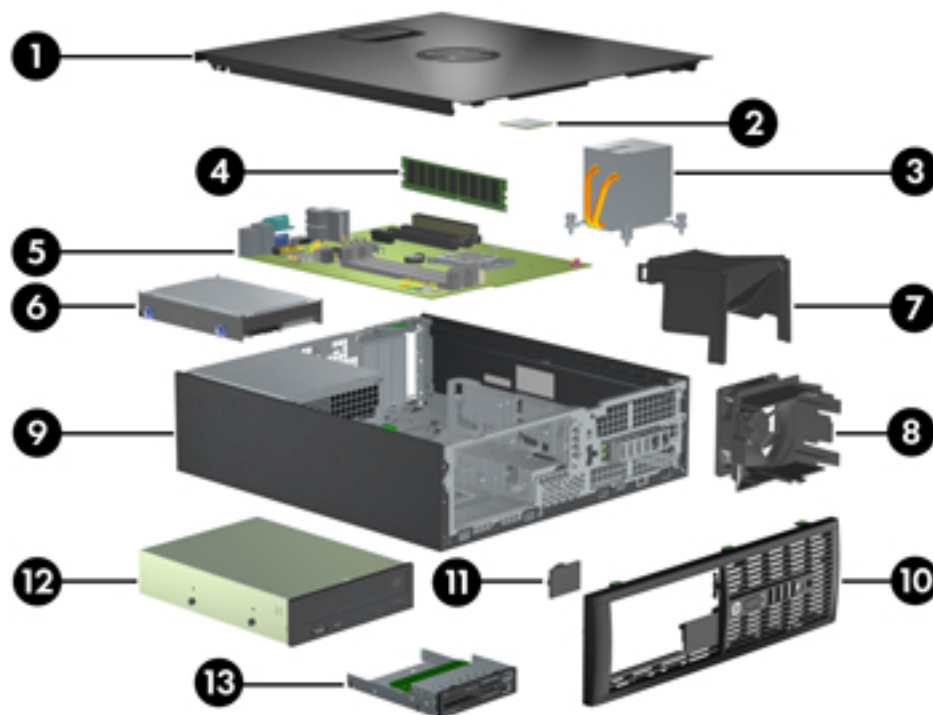

Table 2-4 Workstation component descriptions

Item	Description	Item	Description
1	Access panel	8	System fan
2	Processor (CPU)	9	Chassis
3	Heatsink	10	Front bezel
4	Memory module (DIMM)	11	Speaker
5	System board	12	Optical drive
6	Hard disk drive	13	Optional media reader or second hard disk drive
7	Airflow guide	14	

HP Z210 SFF Workstation front panel components

The following figure shows the front panel of an HP Z210 SFF Workstation. Drive configurations can vary.

Figure 2-5 HP Z210 Workstation front panel

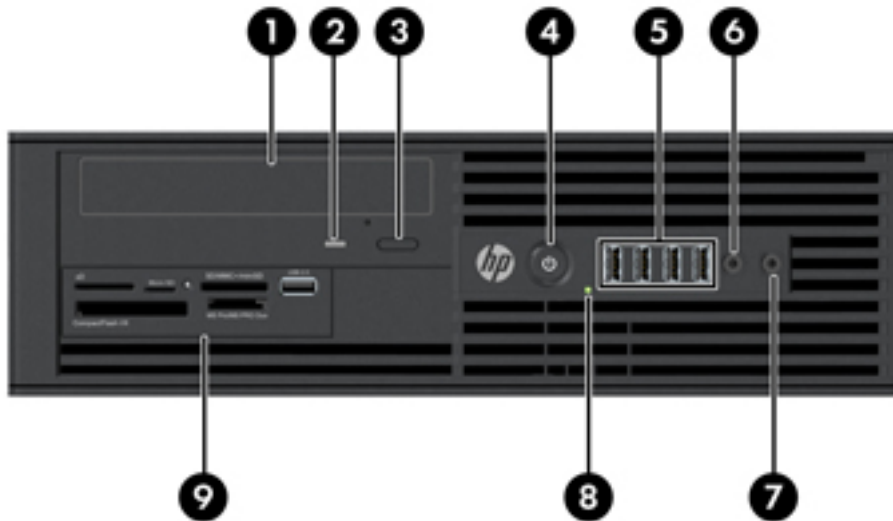







Table 2-5 Front panel components

Item	Symbol	Description	Item	Symbol	Description
1		Optical drive	6		Microphone or headphones connector (software selectable, default mode is microphone)
2		Optical drive activity light	7		Headphones connector
3		Optical drive eject button	8		Hard drive activity light
4		Power button	9		Optional media card reader or second hard disk drive
5		USB 2.0 ports (4)			

HP Z210 SFF Workstation rear panel components





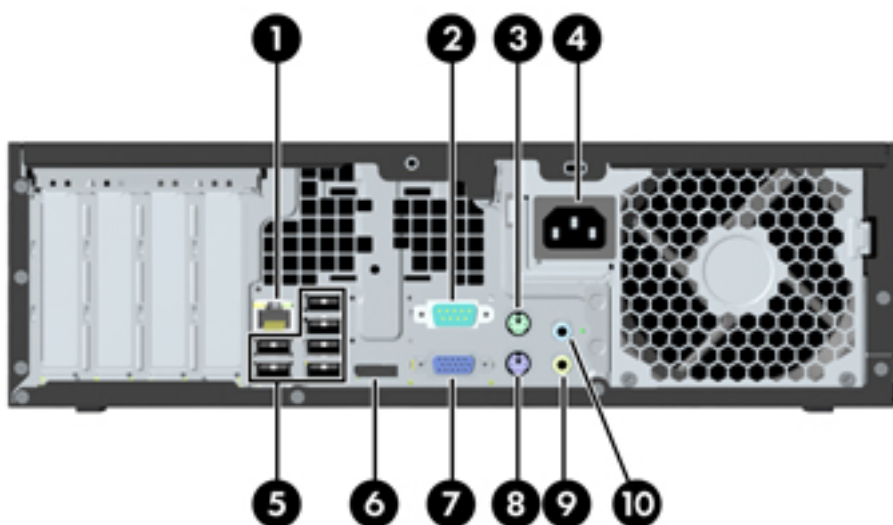



The following figure shows the rear panel of a typical HP Z210 SFF Workstation.

Figure 2-6 HP Z210 SFF Workstation rear panel



NOTE: The labels for the rear panel connectors use industry-standard icons and colors.

Table 2-6 Rear panel components

Item	Symbol	Description	Item	Symbol	Description
1		RJ-45 network connector	6		Display Port (DP)
2		Serial port	7		VGA monitor output
3		PS/2 mouse connector (green)	8		PS/2 keyboard connector (purple)
4		Power cord connector	9		Audio line-out connector (lime green)
5		USB 2.0 ports (6)	10		Audio line-in connector (blue)

3 Setting up the workstation

This chapter describes how to set up the workstation, and includes these topics:

Topics
Ensuring proper ventilation on page 14
Setup procedures on page 15
Converting to desktop configuration on page 17
Adding monitors on page 19
Accessibility on page 24
Security on page 24
Product recycling on page 24

Ensuring proper ventilation

Proper ventilation for the system is important for workstation operation. Follow these guidelines to ensure adequate ventilation:

- Operate the workstation on a sturdy, level surface.
- Place the workstation in an area with adequate ventilation. Provide at least 15.24 cm (6 inches) of clearance at the front and back of the workstation as shown in the following figure.

Your workstation might look different than the one shown.

Figure 3-1 Proper workstation ventilation



- Ensure that the ambient air temperature surrounding the workstation falls within the published limit.

 **NOTE:** The ambient upper limit of 35 C is only good up to 1524 m (5000 ft) elevation. There is a 1 C per 304.8 m (1000 Fft) derating above 1524 m (5000 ft). So, at 3,048 m (10,000 ft), the upper ambient air temperature limit is 30 C.

- For cabinet installation, ensure adequate cabinet ventilation and ensure that the ambient temperature within the cabinet does not exceed published limits.
- Never restrict the incoming or outgoing airflow of the workstation by blocking any vents or air intakes as shown in the following figure.

Figure 3-2 Proper workstation placement

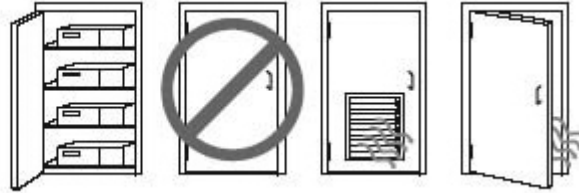

Setup procedures

 **WARNING!** To reduce the risk of electric shock or damage to your equipment:

- Do not disable the power cord grounding plug. The grounding plug is an important safety feature.
 - Plug the power cord in a grounded (earthed) outlet that is easily accessible.
-

To set up the workstation:

1. After unpacking your workstation, find workspace with the proper ventilation to set up the system.
2. Connect the mouse and keyboard to the workstation.

For connector location information, see the rear panel connector section for the workstation in this document.

3. Connect the power cord:

Figure 3-3 Connecting the power cord



⚠ WARNING! To reduce the risk of electric shock or damage to your equipment, observe these practices:

- Plug the power cord into an AC outlet that is easily accessible.
- Disconnect power from the computer by unplugging the power cord from the AC outlet (not by unplugging the power cord from the computer).
- If provided with a three-pin attachment plug on your power cord, plug the cord into a grounded (earthed) three-pin outlet. Do not disable the power cord grounding pin, for example, by attaching a two-pin adapter. The grounding pin is an important safety feature.

📝 NOTE: After setting up the workstation hardware, connect other peripheral components (such as a printer) according to the instructions included with the device.

Converting to desktop configuration

The Z210 Convertible Mini Tower (CMT) Workstation can be operated in the mini-tower or the desktop configuration. Follow these steps to convert to desktop configuration operation:

 **NOTE:** See the workstation *Maintenance and Service Guide* for installation details for the following steps.

1. Prepare the workstation for component installation (see [Preparing the workstation for component installation on page 34](#)).
2. Remove the front bezel from the workstation.
3. Press gently on the edges of the optical drive bay filler panel, and remove it from the front bezel as shown in the following figure.

Figure 3-4 Removing the ODD bay filler panel

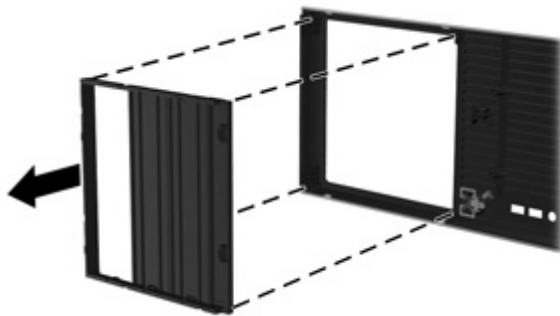

4. Rotate the filler panel 90 degrees to a horizontal position.
5. Align the slots in the filler panel frame with the tabs in the front bezel. Press the optical drive filler panel back into the front bezel until it snaps into place as shown in the following figure.

Figure 3-5 Installing the ODD bay filler panel

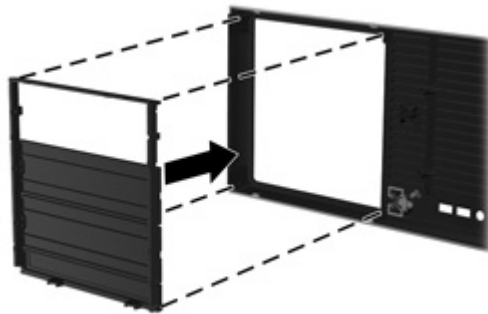

6. On the back of the front bezel, squeeze the HP logo mounting tabs (1) and press the logo outward (2) as shown in the following figure.

Figure 3-6 Rotating the HP logo

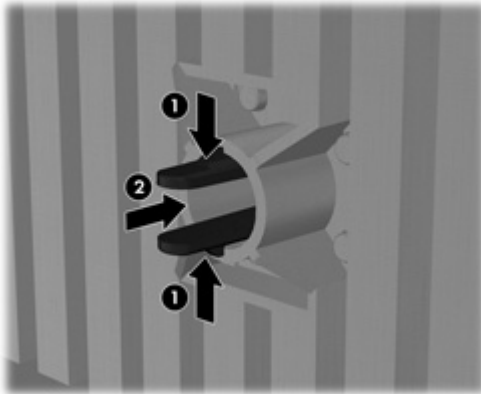

Rotate the HP logo 90 degrees counterclockwise, and then release the logo and press it back into place in the front bezel.

7. Remove the EMI filler panels and remove the optical disk drive from the chassis.
8. Rotate the EMI filler panels and the optical drive 90 degrees as shown in the figure below, and then reinstall them (see [Installing an optical drive \(desktop configuration\) on page 55](#)).

Figure 3-7 Reinstalling the optical drive



9. Replace the front bezel and the side access panel when finished.

Adding monitors

This section describes how to connect monitors to the workstation.

Using workstation integrated graphics

Depending on CPU configuration, some HP Z210 CMT and SFF workstations support Intel® HD Graphics (integrated graphics) with simultaneous output to two monitors. Refer to the workstation *Maintenance and Service Guide on the Web* at http://www.hp.com/support/workstation_manuals/, or see <http://www.hp.com/go/workstations> for additional information about your workstation.

 **NOTE:** If a PCIe or PCI graphics card is installed, Intel HD Graphics are disabled.

The HP Z210 CMT workstation provides rear-panel connectors for DisplayPort and DVI-I. (See [HP Z210 CMT Workstation rear panel components on page 10.](#))

The HP Z210 SFF workstation provides rear-panel connectors for DisplayPort and VGA. (See [HP Z210 SFF Workstation rear panel components on page 13.](#))

Planning for additional monitors

All graphics cards provided with HP Z Workstations support two simultaneous display monitors (see [Connecting the monitors on page 23](#)). Other cards that support more than two monitors are available. The process for adding monitors depends on your graphics card(s) and the type and number of monitors you want to add.

Use this process to plan for adding more monitors:

1. Assess your monitor needs:

- Determine how many monitors you require.
- Determine the kind of graphics performance that you want.
- Note the type of graphics connector used by each monitor. HP provides graphics cards with DisplayPort (DP) and DVI interfaces, but you can use adapters and third-party cards to interface to other graphics formats, including DVI-I, HDMI, or VGA.

 **TIP:** Some adapters for older legacy hardware may cost more than others. You may want to compare the cost of acquiring adapters versus the cost of getting a newer monitor that doesn't need adapters.

2. Determine if you need additional graphics cards:

- Consult the graphics card documentation to determine how many monitors you can connect to the card.
 - You may need to acquire adapters to match the card output to the monitor connector. (See [Matching graphics cards to monitor connectors on page 21.](#))

 **NOTE:** Monitors with resolutions above 1920 x 1200 pixels at 60Hz require a graphics card with either Dual Link DVI or Display Port output. To get native resolution with DVI, however, you must use a DL-DVI cable, not standard DVI-I or DVI-D cables.

- If necessary, plan to acquire a new graphics card to drive additional monitors.

 **NOTE:** HP Z Workstations do not support all graphics cards. Make sure a new graphics card is supported before purchasing it. To find out how to list supported graphics cards and get other information, see [Finding supported graphics cards on page 21](#).

- The maximum number of monitors that a graphics card supports depends on the card. Most cards provide outputs for two monitors, some graphics cards provide three or four outputs.

 **NOTE:** Many graphics cards provide more than two monitor outputs but limit you to using only two at a time. Consult the graphics card documentation or look up information on the card according to the procedure in [Finding supported graphics cards on page 21](#).

 **NOTE:** Some graphics cards support multiple monitors by multiplexing the monitor signal across multiple outputs. This may reduce graphics performance. Consult the graphics card documentation or look up information on the card according to the procedure in [Finding supported graphics cards on page 21](#).

- Make sure the card outputs match the input required by the monitors. (See [Identifying monitor connection requirements on page 22](#).)
- The different models of HP Z Workstations have different limits on the mechanical size, data speed, and power available for additional graphics cards. In addition, the usual practical limit for graphics cards is two per computer. Refer to the [Expansion card slot identification on page 41](#) section to make sure a new graphics card will work for your computer.

3. If you find that you must add a new graphics card or cards:

- a.** Determine which HP-supported graphics card will best fit your needs in terms of number of monitors, compatibility with the monitors you plan to use, and performance. To find out more about supported graphics cards, see [Finding supported graphics cards on page 21](#).
- b.** Make sure you have the correct drivers for the graphics card.
- c.** Install the first graphics card as per the instructions in this manual. (See [Installing PCI/PCIe devices on page 41](#).)
- d.** Configure the monitor in Windows (see [Configuring the monitors using Microsoft® operating systems on page 23](#)) or with a third-party configuration tool (see [Using a third-party graphics configuration utility on page 24](#)).

 **TIP:** To simplify troubleshooting of possible problems, enable the monitors one at a time, i.e., enable the first monitor and then make sure the card, connections, and monitor all work properly before enabling the next monitor.





Finding supported graphics cards

To find out more information about graphics cards supported for your workstation:

1. Go to: <http://www.hp.com/go/quickspecs>
2. In the left hand navigation frame, under **Quickspecs**, click on your region (for example, **Worldwide**).
3. After the page reloads, click on **Workstations** in the left hand navigation frame. This displays an overview page for HP workstations.
4. Click on your workstation model, for example **HP Z210 Workstation**, choosing either HTML or PDF.
5. In the document that is displayed, click on **Technical Specifications-Graphics**. This displays expanded technical information for the graphics cards supported for your workstation.

Matching graphics cards to monitor connectors

The following table describes monitor configuration scenarios.

Graphics card interface connector	Monitor connector		
	VGA	DVI	DISPLAYPORT (DP)
DISPLAYPORT 	DisplayPort to VGA adapter (sold separately)	DP to DVI adapter	No adapter required
DVI 	DVI to VGA adapter	No adapter required	N/A
VGA (ON LEFT)/DVI 	No adapter required	No adapter required	N/A
DMS-59* 	DMS-59 to VGA (sold separately)	DMS-59 to DVI	DMS-59 to DisplayPort

* This interface is a dual-monitor graphics interface card that supports two VGA, two DVI or two DisplayPort monitors.

 **NOTE:** HP graphics cards include monitor cable adapters unless otherwise indicated.

 **NOTE:** VGA graphics cards have the lowest performance while DisplayPort cards have the highest.

Identifying monitor connection requirements

The following are various scenarios for connecting monitors. (See [Matching graphics cards to monitor connectors on page 21](#) for more information about the different graphic cards):

- **Graphics card with DisplayPort output** — If the workstation has a graphics card with four DisplayPort output receptacles, you can connect a monitor to each receptacle. Use the proper adapters if required.
- **Graphics card with DVI output** — If the workstation has a PCIe graphics card with two DVI output receptacles, you can connect a monitor to each DVI receptacle. Use the proper adapters if required.

 **NOTE:** Some HP Z workstations have only one DVI port. However, such workstations will always have a second graphics output option (Display Port or VGA). Note also that many graphics cards provide more than two monitor outputs but limit you to using only two at a time. Consult the graphics card documentation or look up information on the card according to the procedure in [Finding supported graphics cards on page 21](#).

 **NOTE:** Port number 1 on a system with two DVI connections provides the primary display, which is where the POST and BIOS screens appear after a system restart. Usually, this is the lower of the two outputs. (This can be changed in the BIOS settings.)

- **Graphics card with DMS-59 output** — If the workstation has a PCIe graphics card with a DMS-59 output receptacle, use the appropriate adapter to connect your monitors.

Adapters are available to connect the DMS-59 output to two DVI, two VGA, or two DisplayPort monitors.

Connecting the monitors

 **NOTE:** HP-supported graphics cards typically support at least two monitors, as shown in this section; some supported cards support more monitors. Refer to the graphics card documentation for details.

1. Connect the monitor cable adapters (1) (if required) to the workstation, then connect the appropriate monitor cables to the adapters (2) or directly to the graphics card, as shown in the following figure.

Figure 3-8 Connecting the cables to the workstation



2. Connect the other ends of the graphics cables to the monitors as shown below.

Figure 3-9 Connecting cables to the monitors

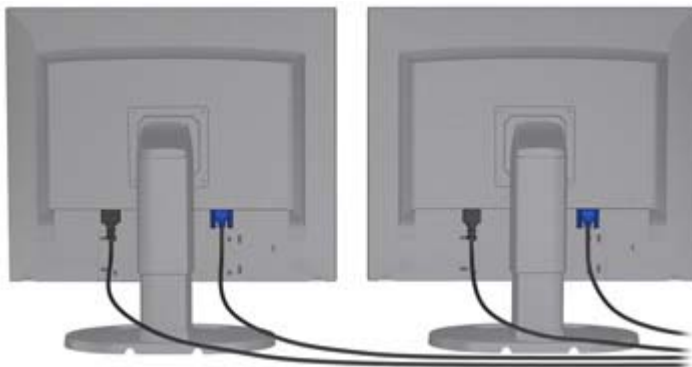

3. Connect one end of the monitor power cord to the monitor and the other end to a grounded power outlet.

Configuring the monitors using Microsoft® operating systems

Refer to Microsoft Help information or the Microsoft Web site for details about monitor configuration procedures.

Using a third-party graphics configuration utility

Third-party graphics cards may include a monitor configuration utility. Upon installation, this utility is integrated into Windows. You can select the utility and use it to configure multiple monitors with your workstation.

Refer to your graphics card documentation for instructions on using the monitor configuration utility.

 **NOTE:** Some third-party configuration utilities require that you enable the monitors in Windows before using the configuration tool. Refer to your graphics card documentation for more information.

 **NOTE:** Monitor configuration utilities are also often available on the HP support Web site.

Refer to the *Linux User Guide* for instructions about using Linux to configure monitors with your workstation.

Customizing the monitor display (Microsoft operating systems only)

You can manually select or change the monitor model, refresh rates, screen resolution, color settings, font sizes, and power management settings.

To change display settings, right-click on the Windows Desktop, then click **Screen resolution** in Microsoft® Windows® 7 Professional/Ultimate.

For more information about customizing your monitor display, see these resources:

- Online documentation provided with the graphics controller utility
- Documentation included with your monitor

Accessibility

HP is committed to developing products, services, and information that is easier to access for all customers, including customers with disabilities and age-related limitations. HP products with Microsoft® Windows preinstalled are designed for accessibility, and these products are tested with industry-leading Assistive Technology products. See <http://www.hp.com/accessibility> for more information.

Security

Some HP workstations have a lock on the side access panel. The key for this lock is shipped attached to the back panel of the workstation chassis.

The workstation includes several security features to reduce the risk of theft and to warn of chassis intrusion. Refer to the *Maintenance and Service Guide* for information about additional hardware and software security features available for your system.

Product recycling

HP encourages customers to recycle used electronic hardware, HP original print cartridges, and rechargeable batteries.

For information about recycling HP components or products, see <http://www.hp.com/go/recycle>.

4 Setting up the operating system

This chapter provides setup and update information for the workstation operating system. It includes these topics:

Topics

[Setting up the Microsoft operating system on page 26](#)

[Setting up Red Hat Enterprise Linux on page 27](#)

[Setting up Novell SLED on page 28](#)

[Updating the workstation on page 29](#)

This chapter also includes information on how to determine that you have the latest BIOS, drivers, and software updates installed on the workstation.

-
- △ **CAUTION:** Do not add optional hardware or third-party devices to the HP workstation until the operating system is successfully installed. Adding hardware might cause errors and prevent the operating system from installing correctly.
-

Setting up the Microsoft operating system

When you first apply power to the workstation, the operating system is installed. This process takes approximately 5 to 10 minutes. Carefully follow the instructions on the screen to complete the installation.

△ **CAUTION:** After installation has started, do *not* turn off the workstation until the process is complete. Turning off the workstation during installation can damage the installation and operation of the software.

For complete operating system installation and configuration instructions, see the operating system documentation that was provided with the workstation. Additional information is available in the online help tool after you successfully install the operating system.

Installing or upgrading device drivers

To install hardware devices after the operating system is installed, you must install the appropriate device drivers before you install the devices. Follow the installation instructions that came with the device. In addition, for optimum performance, your operating system must have the most recent updates, patches, and software fixes. For additional driver and software update information, refer to [Upgrading device drivers on page 30](#).

Transferring files and settings to your Windows workstation

The Microsoft Windows operating system offers data migration tools that helps you choose and transfer files and data from another Windows computer to your Windows operating system workstation.

For instructions on how to use these tools, see the documents at <http://www.microsoft.com>.

Setting up Red Hat Enterprise Linux

HP offers an HP Installer Kit for Linux (HPIKL) to supplement Red Hat box sets and help HP Linux customers customize their system image. The HPIKL contains the HP driver CD and device drivers to successfully setup up the Red Hat Enterprise Linux (RHEL) operating system. The HP Installer Kit for Linux CDs are currently available for download at http://www.hp.com/support/workstation_swdrivers.

To use the drivers in the HP Installer kit for Linux other than RHEL, you must manually extract the drivers from the HP Driver CD and install them. HP does not test the installation of these drivers on other Linux distributions nor does HP support this operation.

Verifying hardware compatibility

To see which Linux versions have been qualified to work on HP Workstations visit http://www.hp.com/support/linux_hardware_matrix.

Installing from RHEL optical media

When installing RHEL on your workstation, follow this procedure prior to booting and installing from the RHEL box set media:

1. With the RHEL install media in the DVD drive, restart the workstation and press the **F9** key within three seconds to display the boot menu. If you miss the boot menu, press **Ctrl-Alt-Del** to restart and wait slightly more or less before pressing **F9**.
2. From the list of available boot sources, under **Legacy boot sources**, pick the optical drive that contains the RHEL install media.

 **NOTE:** Be sure to pick from the list labeled **Legacy boot sources** when selecting the optical drive from which to boot. Do not select from **UEFI boot sources**. Doing so may result in the OS installation being unable to complete.

3. Press **Enter** to continue with system boot and the OS installation process.

Installing with the HP driver CD

To install the HP driver CD, see “Installing with the HP Installer Kit for Linux” in the *HP Workstations for Linux* manual at http://www.hp.com/support/workstation_manuals.

Setting up Novell SLED

HP offers an HP Installer Kit for Linux (HPIKL) to help HP Linux customers customize their system image. The HPIKL contains the HP driver CD and device drivers to successfully setup up the SUSE Linux Enterprise Desktop (SLED) operating system. The HP Installer Kit for Linux CDs are currently available for download at http://www.hp.com/support/workstation_swdrivers.

Setting up SLED on preloaded systems

To set up the SUSE Linux Enterprise Desktop (SLED) on systems preloaded with the operating system:

1. Boot the workstation.
2. Start the Installation Settings and enter the password, network, graphics, time, keyboard settings, and Novell Customer Center Configuration for the workstation.

 **NOTE:** During Installation Settings after the first time after booting the system the Novell subscription can be activated from the Novell Customer Center Configuration screen. Visit the full Novell Customer Center documentation at <http://www.novell.com/documentation/ncc/>.

Installing from SLED optical media

To install SLED on your workstation, follow this boot procedure prior to installing from the SLED media:

1. With the SLED install media in the DVD drive, restart the workstation and press the **F9** key within three seconds to display the boot menu. If you miss the boot menu, press **Ctrl-Alt-Del** to restart and wait slightly more or less before pressing **F9**.
2. From the list of available boot sources, under **Legacy boot sources**, pick the optical drive that contains the SLED install media.

 **NOTE:** Be sure to pick from the list labeled **Legacy boot sources** when selecting the optical drive from which to boot. Do not select from **UEFI boot sources**. Doing so may result in the OS installation being unable to complete.

3. Press **Enter** to continue with system boot and the OS installation process.

Installing with the HP driver CD

To install the HP driver CD, see “Installing with the HP Installer Kit for Linux” in the *HP Workstations for Linux* manual at http://www.hp.com/support/workstation_manuals.

Updating the workstation

HP is constantly working on improving your total workstation experience. To ensure that the workstation leverages the latest enhancements, HP recommends that you install the latest BIOS, driver, and software updates on a regular basis.

Updating the workstation after first boot

After successfully booting the workstation for the first time, you should follow these guidelines to ensure that the workstation is up-to-date:

- Ensure that you have the latest system BIOS loaded. See [Upgrading the BIOS on page 29](#) for instructions.
- Ensure that you have the latest drivers for your system. See [Upgrading device drivers on page 30](#) for instructions.
- Become familiar with your available HP resources.
- Consider a subscription to Driver Alerts at <http://www.hp.com/go/subscriberschoice>.

Upgrading the BIOS

For optimum performance, determine the BIOS revision on the workstation, and upgrade it if necessary.

Determining current BIOS

To determine the current BIOS of the workstation during system power up:

1. Wait for F10=setup to appear on the lower right corner of the screen.
2. Press **F10** to enter the F10 Setup utility.

The F10 Setup utility displays the workstation BIOS version under **File > System Information**.

3. Note the workstation BIOS version so that you can compare it with the BIOS versions that appear on the HP website.

Upgrading BIOS

To find and download the latest available BIOS, which includes the latest enhancements:

1. Go to <http://www.hp.com/go/workstationsupport>.
2. Select **Download Drivers and Software** from the left menu column under Tasks.
3. Follow the instructions to locate the latest BIOS available for the workstation.
4. If the BIOS on the Web site is the same as the version on your system, no further action is required.
5. If the BIOS on the Web site is a version later than the one on your system, download the appropriate version for the workstation. Follow the instructions in the release notes to complete the installation.

Upgrading device drivers

If you install a peripheral device (such as a printer, display adapter, or network adapter), confirm you have the latest device drivers loaded. If you purchased your device through HP, visit the HP Web site to download the latest drivers for your device. These drivers have been tested to ensure the best compatibility between your device and your HP workstation.

If you did not purchase your device from HP, HP recommends visiting the HP Web site first to see if your device and its drivers have been tested for HP workstation compatibility. If no driver is available, visit the device manufacturer's Web site to download the latest drivers.

To upgrade device drivers:

1. Go to <http://www.hp.com/go/workstationsupport>.
2. Select **Download Drivers and Software** from the left menu column under Tasks.
3. Follow the instructions to find the latest drivers available for the workstation.

If a needed driver is not found, see the Web site of the manufacturer of the peripheral device.

5 Restoring the operating system

This chapter describes how to restore the Windows or Linux operating system. It includes these topics:

Topics

[Restore method on page 31](#)

[Ordering backup software on page 32](#)

[Restoring Windows 7 on page 32](#)

[Restoring Novell SLED on page 33](#)

Restore method

The Windows 7 operating system can be reinstalled using the HP Recovery Manager

HP Recovery Manager reinstalls the Windows operating system and device drivers (for devices included with the system) to a near-factory state. The process does not back up or recover data on the hard drive. Some application software might not be restored using this process and must be installed from the appropriate application CD.

△ **CAUTION:** This method restores the operating system, but not data. Data must be backed up regularly to avoid loss.

Ordering backup software

You can order a recovery disk set from the HP support center. To obtain the support center telephone number for your region see <http://www.hp.com/support/contactHP>. Request the Windows 7 32-bit or 64-bit system recovery media kit.

Restoring Windows 7

This section describes how to restore Windows 7.

Ordering the HP Recovery Manager media

If you ordered restore media with your workstation, the media is included with your workstation components.

If you did not order restore media, call HP Support and request the Windows 7 32-bit or 64-bit system recovery media kit. For worldwide technical support phone numbers, see <http://www.hp.com/support>.

Restoring the operating system

 **NOTE:** Windows 7 provides a backup and restore application as well. To learn more about this application, see the Microsoft Web site.

 **CAUTION:** Before you restore the operating system, back up your data.

When you run HP Recovery Manager from media, the process deletes all information on the primary hard drive, including all partitions.

To restore Windows 7:

1. Boot from the first disk in the HP Recovery Manager DVD set to start the system recovery process.
2. Follow the prompts to restore your operating system.

Some application software might not be restored using this process. If software is not restored, install it from the appropriate application DVD.

Restoring Novell SLED

The SLED restore media is required to restore the Linux operating system.

Creating restore media

The SUSE Linux Enterprise Desktop preload includes a SUSE ISO icon on the desktop. You can click this icon to go to the `/iso` directory. The `/iso` directory contains all iso images used to preload your workstation. To recover or restore the original image, follow the instructions in the readme file in the `/iso` directory to copy the ISO image file onto CDs.

 **NOTE:** Make copies of the ISO recovery images on CD as backup files in case your workstation experiences a hard drive failure.

6 Preparing for component installation

To facilitate the installation of components, several steps can be taken to prepare the workstation. This section describes how to prepare your workstation for component installation.

Disassembly and installation preparation

Use the following table to determine the order of workstation disassembly required before installing components. (Your workstation components may be different than those listed.)

Table 6-1 Workstation component installation

To install...	Remove...	Then remove...	Then...	Then...
Memory	Chassis locks*	Side access panel		
Expansion card (PCI/PCIe)	Chassis locks	Side access panel		
Hard drive	Chassis locks	Side access panel	Rotate front drive cage to upward position (Z210 SFF)	Rotate power supply to upright position (Z210 SFF)
Optical drive	Chassis locks	Side access panel	Remove front bezel	



* See the workstation *Maintenance and Service Guide* for chassis lock locations and operation instructions.

Preparing the workstation for component installation



To prepare the workstation:

 **NOTE:** The workstation contains green plastic touch points at locations where you must manipulate a button or lever. Green touch points on some components indicate tool-less removal of those components.

1. Disconnect power from the system.
2. Unlock the side access panel or remove any chassis locks.
3. Remove the side access panel as shown in the following illustrations.

Z210 CMT	Z210 SFF
<p>Pull up on the handle (1), slide the cover 1.27 cm (0.5 inches) toward the rear of the system (2), then rotate the cover off the chassis (3).</p> 	<p>Lift the side access panel handle (1), and remove the side access panel (2).</p> 

4. Raise the expansion card retention clamp and remove the expansion card slot cover as shown in the following illustrations, if applicable.

Z210 CMT	Z210 SFF
<p>Open the card retention clamp by pressing down at the green touch points (1), and then lift the slot cover from the chassis (2).</p> 	<p>Lift the card retention clamp at the green touch point to open it, then lift the slot cover from the chassis.</p> 

5. (HP Z210 CMT only) Remove the front bezel as shown in the following illustration. Lift the release tabs (1), and then rotate the front bezel off the chassis (2).

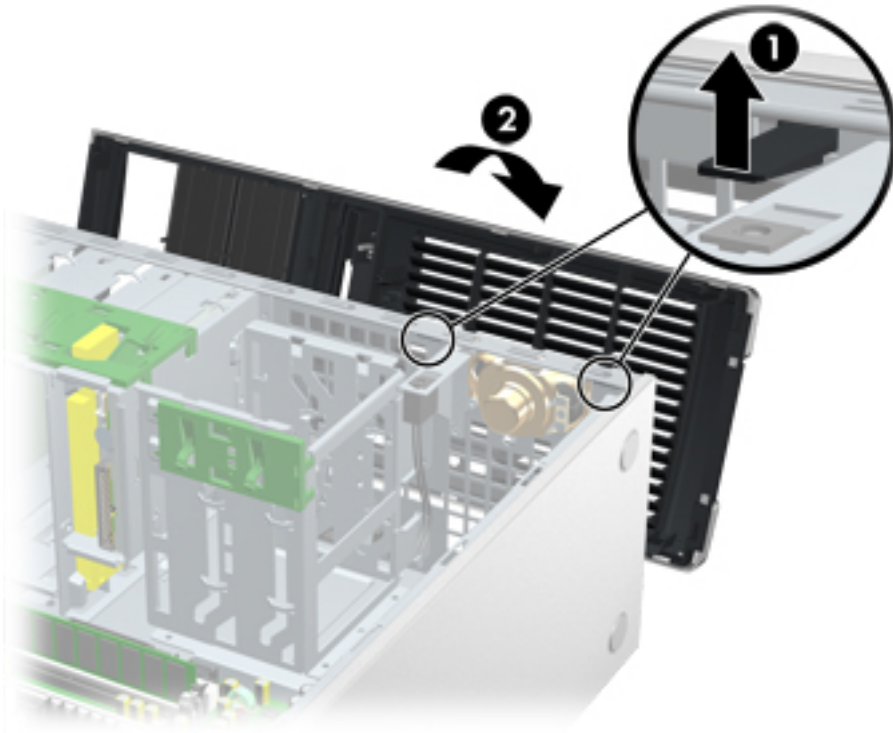

6. (HP Z210 SFF only) Rotate the front drive cage to the upright position.

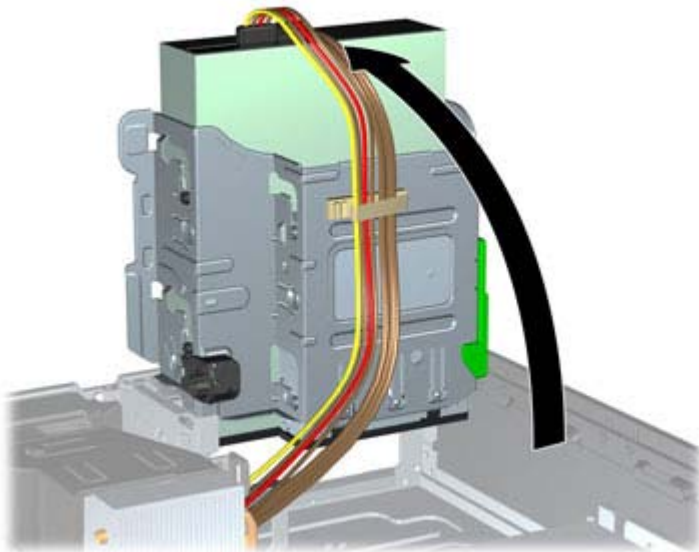

7. (HP Z210 SFF only) Rotate the power supply to its upright position.

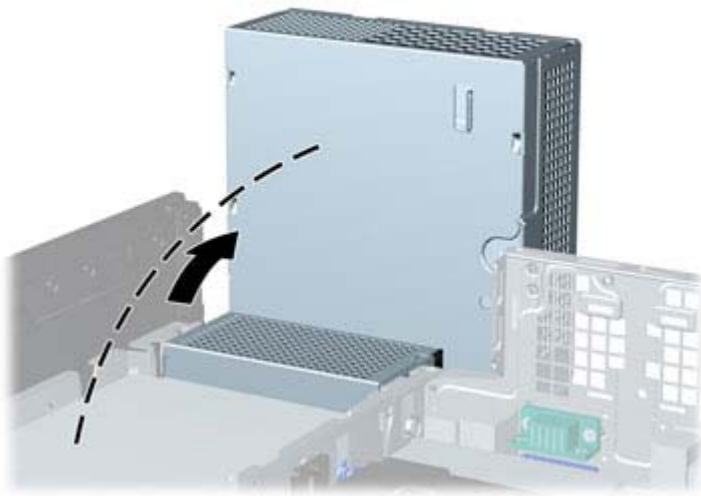

The workstation is now prepared for the component installation procedures described in the chapters that follow.

7 Installing memory

This section describes how to add memory to your workstation.

Supported memory configurations

Refer to the quick specs at <http://www.hp.com/go/productbulletin> for specific DIMM compatibility information for HP workstations.

 **NOTE:**

- Install only HP-approved, unbuffered DDR3 DIMMs.
- HP Z210 CMT and SFF Workstations support Error Checking and Correcting (ECC) and non-ECC DIMM memory modules.
- Do not intermix ECC and non-ECC memory. The system will not boot and will produce a memory error.
- For maximum performance, install DIMM memory modules in pairs of the same size.
- Install DIMM memory modules in the order shown below.

The following table describes the memory configurations supported by the HP Z210 Workstations.

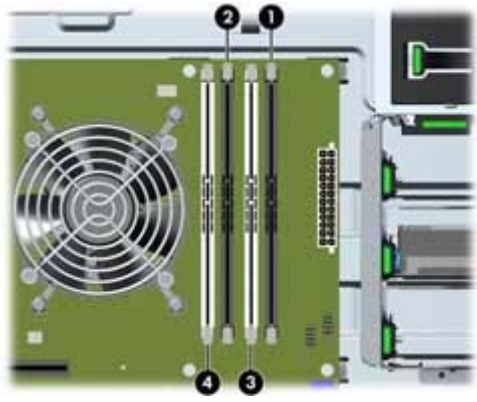
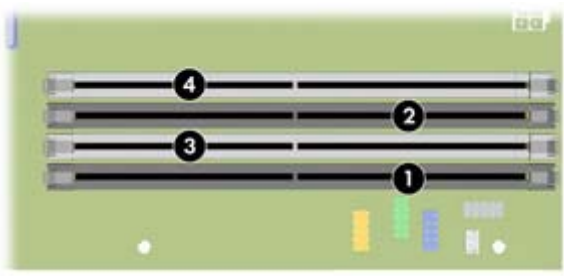
Z210 CMT	Z210 SFF
Supported configurations <ul style="list-style-type: none">• Four DIMM slots• Memory configuration from 1 GB to 32 GB	Supported configurations <ul style="list-style-type: none">• Four DIMM slots• Memory configuration from 1 GB to 32 GB
DIMM installation order 	DIMM installation order 

Installing a DIMM

To install a DIMM:

1. Follow the procedures described in [Preparing for component installation on page 34](#) to prepare the workstation for component installation.
2. Push gently outward on the DIMM socket levers as shown in the following illustration.

Figure 7-1 Opening DIMM socket levers

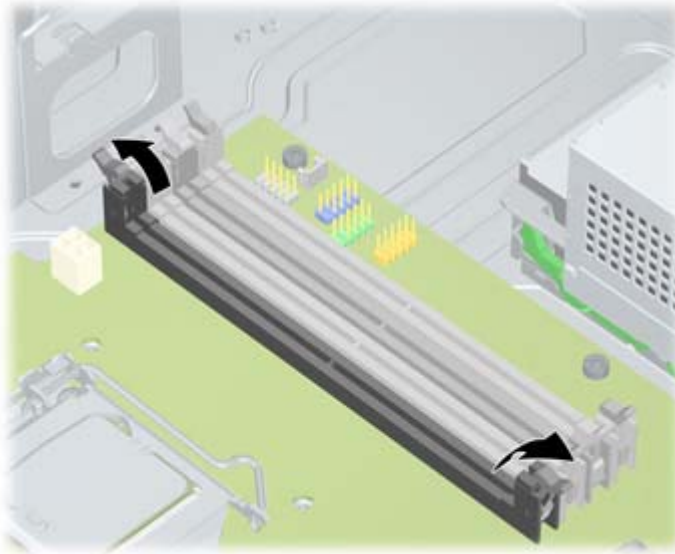

3. Align the DIMM connector key with the DIMM socket key, and then seat the DIMM firmly in the socket (1) as shown in the following illustration.

△ **CAUTION:** DIMMs and their sockets are keyed for proper installation. To prevent socket or DIMM damage, align these guides properly when installing DIMMs.

Figure 7-2 Seating the DIMM

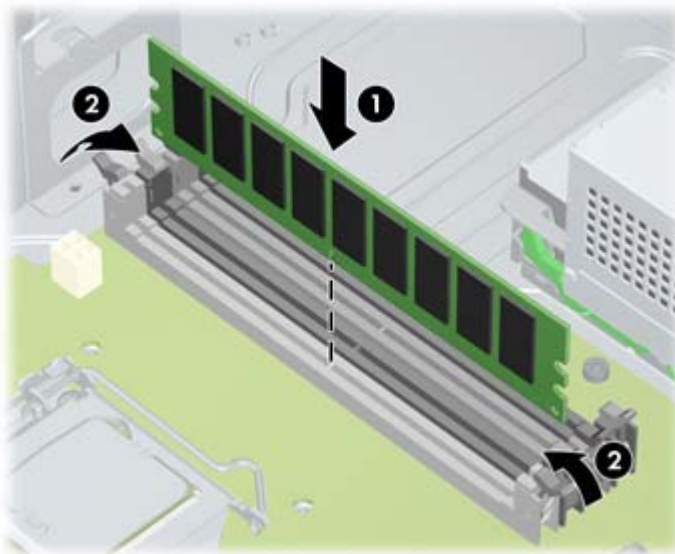

4. Secure the socket levers (2).
5. Replace all components that were removed in preparation for component installation.

8 Installing PCI/PCIe devices

This section describes how to install a PCI or PCIe card in the workstation. To increase the performance and functionality of your system, PCI/PCIe devices such as graphics cards or audio cards can be installed in the expansion card slots on the workstation.

Expansion card slot identification

The following tables describe the expansion card slots in the HP Z210 Workstations.

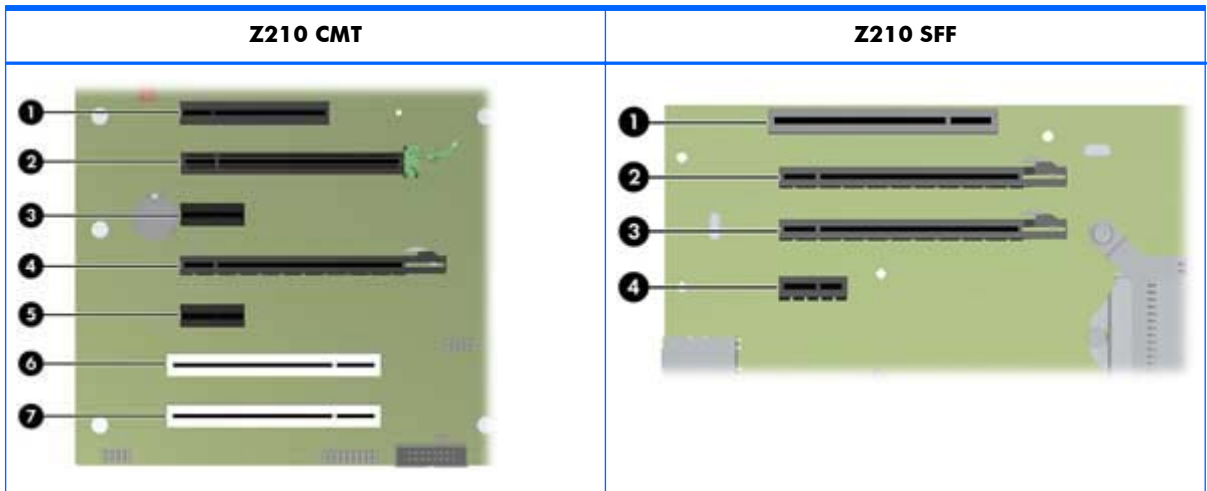

Slot description	Slot power	Slot description	Slot power
1-PCIe2 - x8(4)	25W	1-PCI 32b/33Mhz	25W
2-PCIe2 - x16	75W	2-PCIe2 - x16	45W
3-PCIe2 - x1	10W	3-PCIe2 - x16 (4)	25W
4-PCIe2 - x16(4)	25W	4-PCIe2 - x1	10W
5-PCIe2 - x1	10W		
6-PCI 32b/33Mhz	25W		
7-PCI 32b/33Mhz	25W		

NOTE: The x1, x4, x8, and x16 designators describe the mechanical (physical) length of the slot. The number in parentheses lists the number of electrical PCIe lanes routed to the expansion slot. For example, x8(4) means that the expansion slot is mechanically a x8 length connector, with four PCIe lanes connected.

Power limitations for graphics cards

△ **CAUTION:** To prevent damage, the overall power consumption of the workstation (including I/O cards, CPU, and memory) must not exceed the maximum rating of the workstation power supply.

When planning, purchasing, and installing graphics cards in your workstation, observe the following power limitations:

- **Z210 CMT**

- Maximum allowable graphics card power for Slot 2 is 150W. Note that 75W is available from the system board and an additional 75W directly from the PSU (using the 6-pin power connector from the power supply). If a second graphics card is installed in Slot 4, the combined power consumption of both cards must not exceed 150W.

 **NOTE:** If you use a graphics card with greater than 75 watts of power, leave the adjacent slot empty for thermal cooling considerations.

- Slot 4 is mechanically x16 with four PCIe lanes connected; it supplies 25W of power. Do not exceed this power limitation when installing a second graphics card in this slot.

- **Z210 SFF**

- Maximum allowable graphics card power for Slot 2 is 45W. If a second graphics card is installed in Slot 3, the combined power consumption of both cards must not exceed 45W.
- Overall power capacity of Slots 1 through 4 is 80W.

Installing an expansion card

 **NOTE:** The following procedure describes how to install an expansion card in a typical HP Z workstation. Your workstation may look different.

To install a PCI or PCIe expansion card:

1. Follow the procedures described in [Preparing for component installation on page 34](#) to prepare the workstation for component installation.

2. Align the card keyway with the slot key, and then firmly seat the card in the slot as shown in the following illustration (1).

Figure 8-1 Installing an expansion card (Z210 CMT shown)

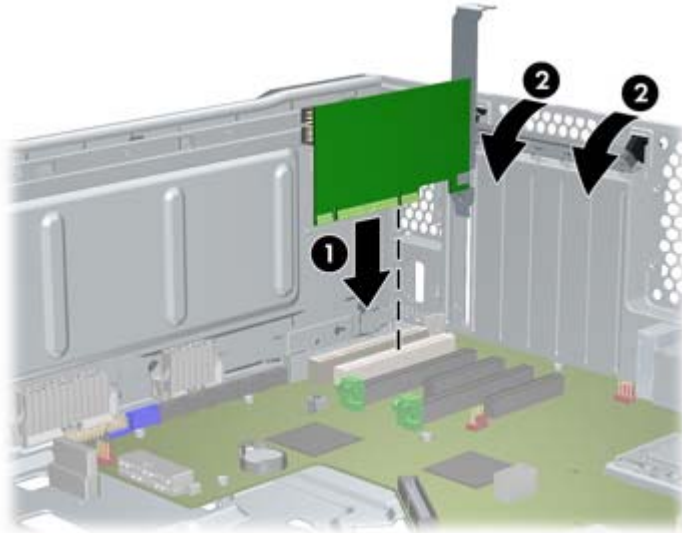

3. Close the retention clamp by rotating it downward (2) as shown in the illustration above.

 **NOTE:** For the Z210 SFF Workstation, close the expansion slot retention clamp making sure all cards are seated.

Figure 8-2 Closing the expansion card retention clamp (Z210 SFF)



4. Connect all necessary power and interface cables to the card (follow instructions that came with the expansion card).
5. Replace all components removed in preparation for component installation.

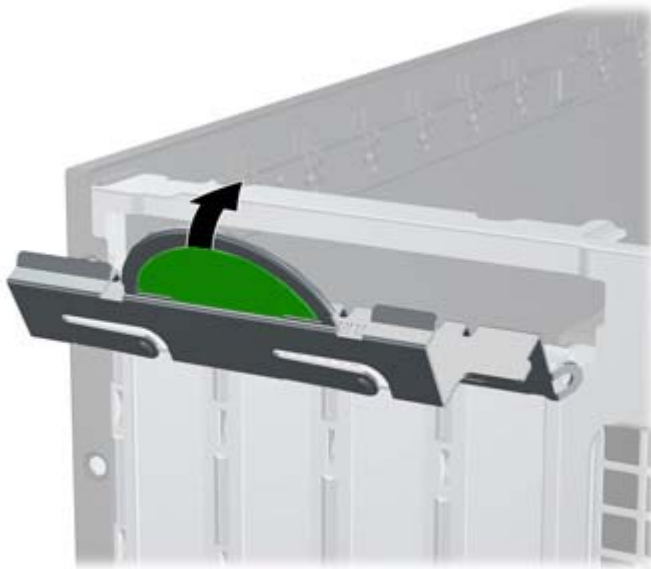

9 Installing hard disk drives

This section describes how to install a hard disk drive (HDD) in the workstation.

HDD configuration

The following table contains hard disk drive installation configuration information.

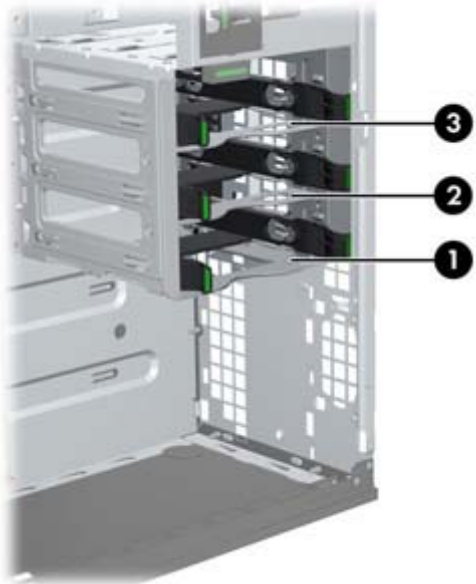
Z210 CMT	Z210 SFF
<p>HDD bays are designed to permit easy installation. Data cables are pre-connected in the workstation based on the factory configuration delivered.</p> <p>The workstation typically ships with an HDD, but additional drives can be added to expand data storage:</p> <ul style="list-style-type: none">• Refer to the service label on the side access panel of your workstation to determine the location of the SATA Gen 3 (6 Gbit/sec) and Gen 2 (3 Gbit/sec) ports.• Additional HDDs must be added in a specific sequence, depending on the type of workstation.• Once installed, the HDDs are assigned drive letters, with C:\ being the typical boot disk. Drive letters are assigned using the Computer Setup (F10) Utility.• With additional HDDs installed, the workstation boot sequence can be modified so that the workstation boots from one of the additional drives. Boot sequence is specified using the Computer Setup (F10) Utility. <p>With additional HDDs installed, you have hard disk space for additional programs, data files, and backup.</p> <p>Refer to the workstation <i>Maintenance and Service Guide</i> at http://www.hp.com/support/workstation_manuals to learn how many HDDs the workstation can accommodate, drive installation order, and boot sequencing procedures.</p>	

Z210 CMT	Z210 SFF
<p>Drive and cable configuration</p> <p>HDD bays are numbered 4 through 6 on the chassis. Each HDD bay contains a mounting sled, allowing tool-less installation and removal of hard disk drives.</p> <p>The cables plug into the system board connectors in the following manner:</p> <ul style="list-style-type: none"> • SATA HDD cables plug into SATA ports starting at SATA port zero. • Blue SATA ports (labeled zero and one) support SATA Gen 3 (6 Gbit/sec). For best performance, use SATA Gen 3 data cables to connect primary (SATA Gen 3) hard disk drives to SATA ports zero and one. 	<p>Drive and cable configuration</p> <p>The HDD bays are not labeled on the chassis.</p> <p>The cables plug into the system board connectors in the following manner:</p> <ul style="list-style-type: none"> • SATA HDD cables plug into SATA ports starting at SATA port zero. • Blue SATA ports (labeled zero and one) support SATA Gen 3 (6 Gbit/sec). For best performance, use SATA Gen 3 data cables to connect primary (SATA Gen 3) hard disk drives to SATA ports zero and one.
<p>HDD installation order</p> 	<p>HDD installation order</p> 

Installing a hard disk drive

This section describes how to install a hard disk drive in the workstation.

Installing an HDD in an HP Z210 CMT Workstation

To install an HDD:

1. Follow the procedures described in [Preparing for component installation on page 34](#) to prepare the workstation for component installation.

2. Select a drive bay in which to install the hard disk drive and remove its mounting sled.

Figure 9-1 Removing the mounting sled

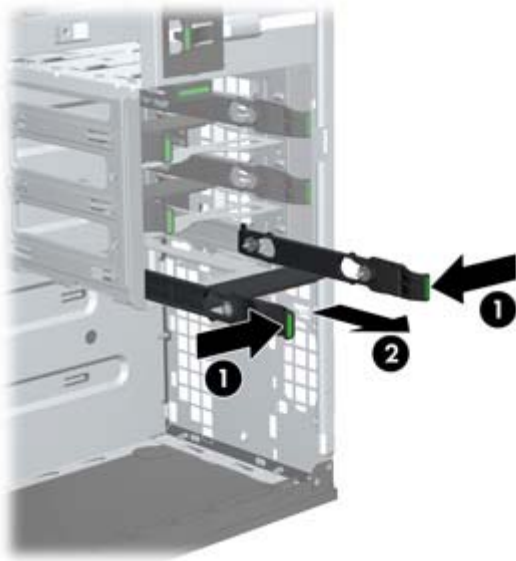

3. Install the HDD into the mounting sled as shown in the following figure.

Figure 9-2 Installing the HDD in the mounting sled

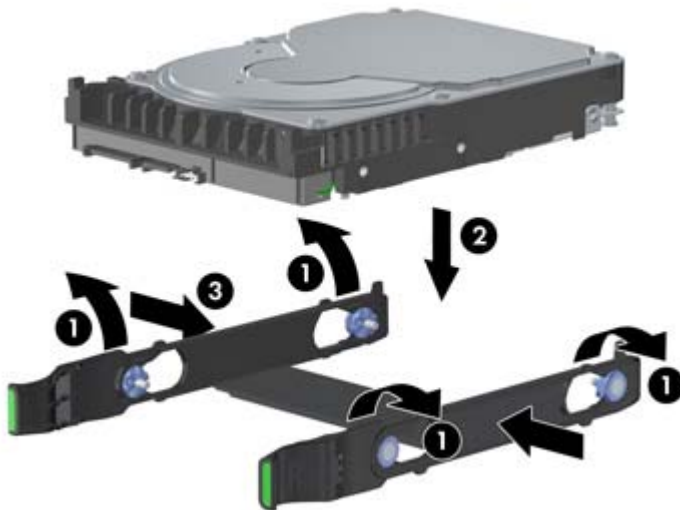

4. Push the sled containing the HDD into the selected bay until it snaps into place (1) as shown in the following figure.

Figure 9-3 Installing the HDD drive

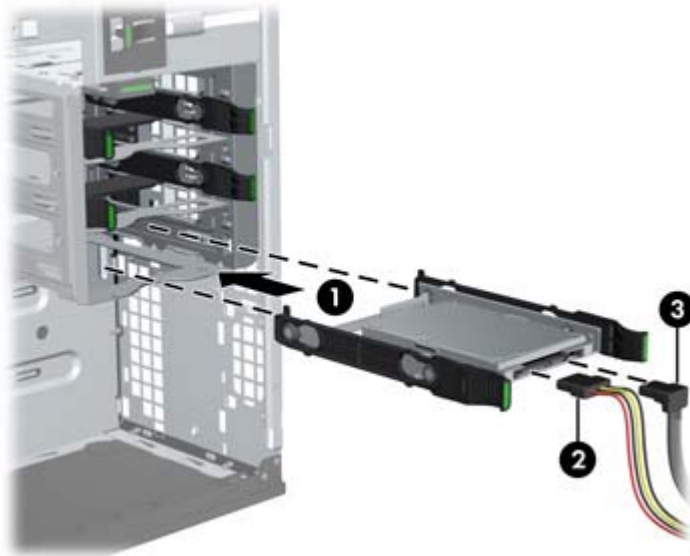

5. Attach a power cable (2), and a data cable (3), to the hard disk drive.

△ **CAUTION:** To avoid crushing or pinching the data cable when you replace the access panel, use the HP-supplied data cable with right-angle connectors.

📝 **NOTE:** Connect data cables to lower-numbered drive connectors first on the system board. To identify hard disk drive ports, refer to the workstation service label on the side access panel.

NOTE: Blue SATA ports (numbered zero and one) support SATA Gen 3 (6 Gbit/sec).

6. Replace all components that were removed in preparation for component installation.

Installing an HDD in an HP Z210 SFF Workstation

To install an HDD:

1. Follow the procedures described in [Preparing for component installation on page 34](#) to prepare the workstation for component installation.

2. Rotate the drive cage to its upright position.

Figure 9-4 Rotating the Drive Cage Up

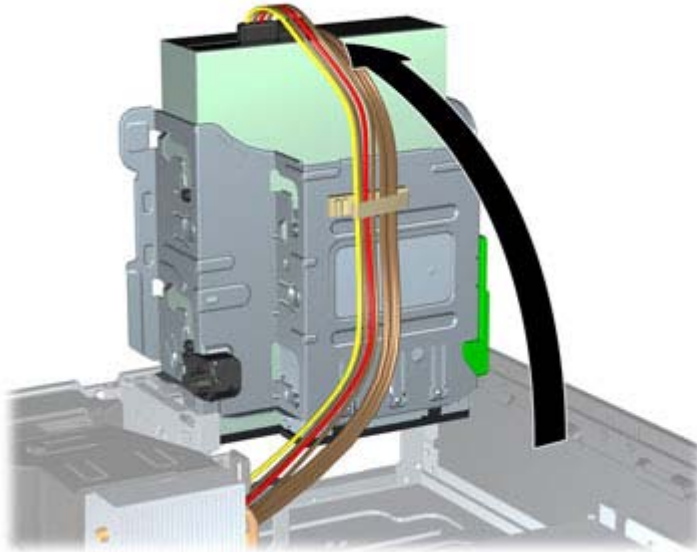

3. Rotate the power supply to its upright position. The hard drive is located beneath the power supply.

Figure 9-5 Rotating the power supply up

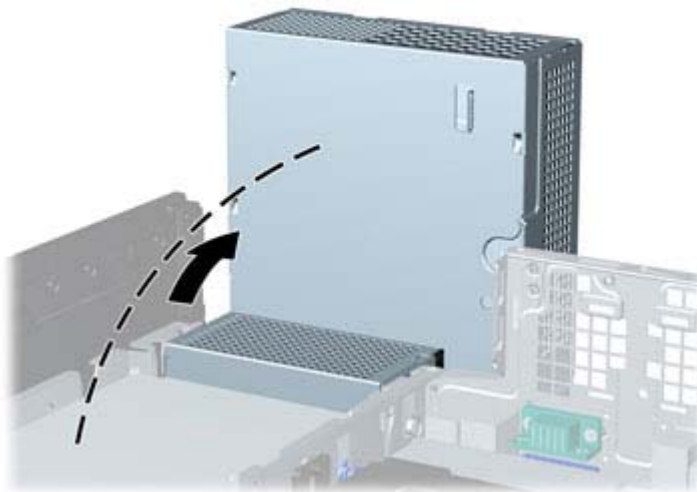

4. Disconnect the power cable (1) and data cable (2) from the hard drive.

Figure 9-6 Disconnecting power and data cables from the primary HDD

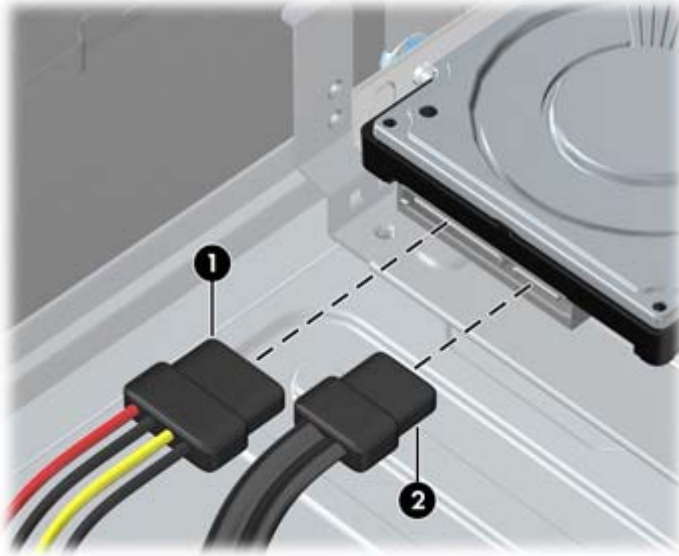

5. Press down on the green release latch next to the hard drive (1). While holding the latch down, slide the drive forward until it stops, then lift the drive up and out of the bay (2).

Figure 9-7 Removing the primary hard drive

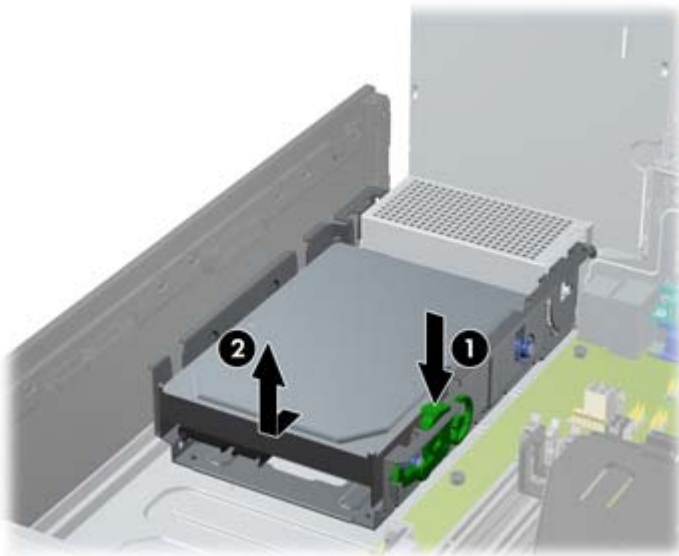

6. To install a new hard drive, move the silver and blue isolation mounting guide screws from the old hard drive to the new hard drive.

Figure 9-8 Installing the hard drive guide screws



You can also install a 6.4 cm (2.5 in.) small form factor hard drive in the primary drive bay:

- a. Transfer the silver and blue isolation mounting guide screws from the old hard drive to a drive carrier.
- b. Use the black M3 screws from the front of the chassis to mount the small form factor drive to the carrier (2).

Figure 9-9 Attaching the drive to a carrier

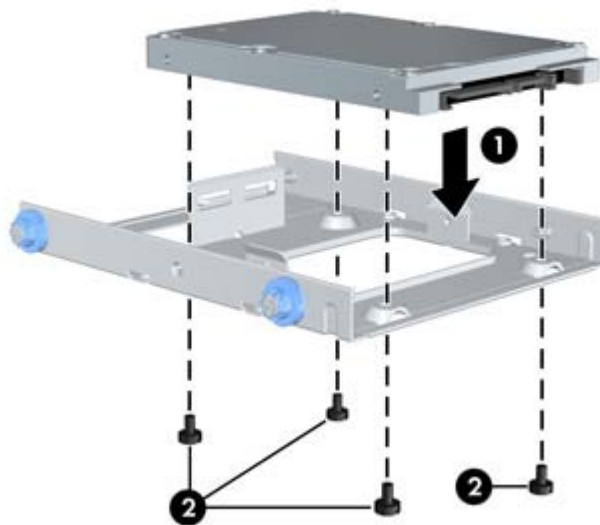

7. Align the guide screws with the slots on the chassis drive cage, press the hard drive down into the bay, then slide it back until it stops and locks in place.

Figure 9-10 Installing the hard drive (drive carrier shown)

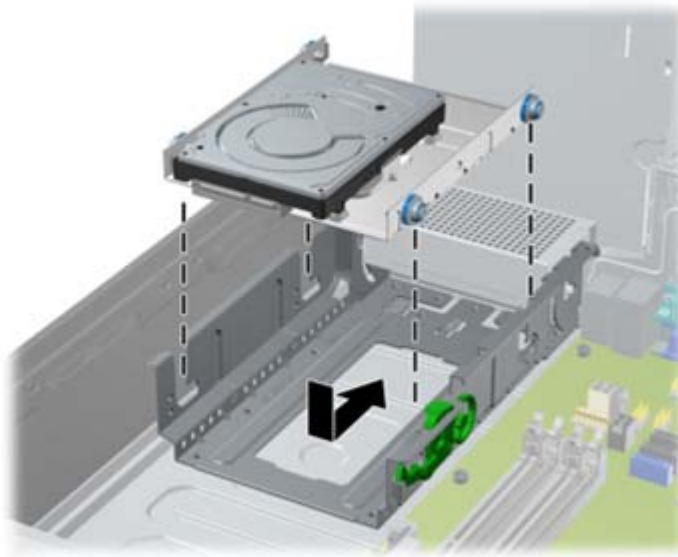

8. Rotate the drive cage and the power supply down to their normal positions.
9. Replace all components that were removed in preparation for component installation.

Installing a secondary HDD or media card reader into a Z210 SFF

You can install an 8.89 cm (3.5 in) hard drive underneath the 13.3 cm (5.25 in) optical drive. A media card reader can also be installed at this location. If an optical drive is present, you must remove it to install the hard drive.

To install a hard drive or media card in the drive cage:

1. Follow the procedures described in [Preparing for component installation on page 34](#) to prepare the workstation for component installation.
2. Remove the front bezel.
3. Remove the optical disk drive if it is present. (See [Installing an optical drive in an HP Z210 SFF Workstation on page 56.](#))

4. Place the drive's guide screws into the J-slots in the drive bay. Then slide the drive toward the front of the computer until it locks into place.

 **TIP:** Angle the drive toward one side of the chassis to line up the guide screws with the slots.

Figure 9-11 Installing a drive into the drive cage (media card reader shown)



5. Connect the drive cables:
 - a. If installing a second hard drive, connect the power and data cables to the rear of the drive and connect the other end of the data cable to the next available (unpopulated) SATA connector on the system board by following the numbered sequence of the connectors. To identify hard disk drive ports, refer to the workstation service label on the side access panel.
 - b. If installing a media card reader, connect the USB cable from the media card reader to the USB connector on the system board labeled MEDIA. If the media card reader includes a 1394 port, connect the 1394 cable to the 1394 PCI card.
6. Replace the optical drive. (See [Installing an optical drive in an HP Z210 SFF Workstation on page 56.](#))
7. Replace the front bezel.
8. Replace the access panel.
9. Replace all components that were removed in preparation for component installation.

10 Installing optical disk drives

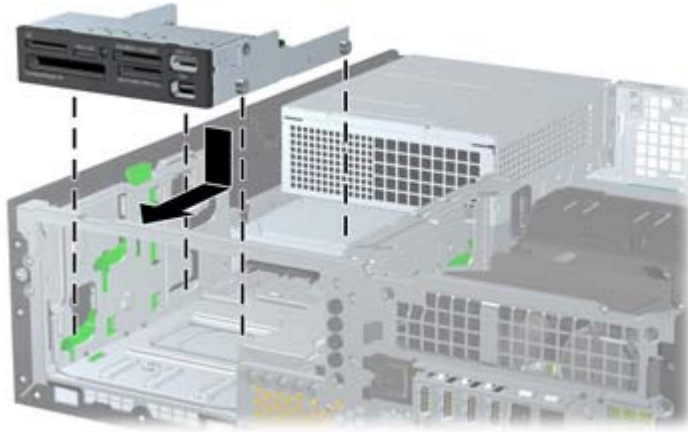
This section describes how to install an optical disk drive (ODD) in the workstation.

Installing an optical drive in an HP Z210 CMT Workstation

This section describes how to install an optical disk drive in the HP Z210 CMT Workstation in the mini-tower and desktop configurations.

Installing an optical drive (mini-tower configuration)

1. Follow the procedures described in [Preparing for component installation on page 34](#) to prepare the workstation for component installation.
2. If necessary, remove the EMI filler from the front of the optical bay.
3. Install four black metric M3 guide screws into the drive. Spare metric M3 screws are stored on the side of the drive bays.

Figure 10-1 Installing the guide screws



4. Align the screws with the grooves in the drive bay and gently slide the drive into the casing. Slide the drive completely in until it snaps into place.

△ **CAUTION:** Verify that the optical disk drive is secure in the workstation chassis by pulling on the drive to see if it can be easily disengaged. Failure to properly secure the drive can damage the drive when moving the workstation.

Figure 10-2 Inserting the ODD into the casing



5. Connect the power and data cables to the optical disk drive and system board as shown in the following figure. Refer to the side access panel service label for the location of the SATA connectors. Connect the data cable in the next available connector.

Figure 10-3 Connecting ODD power and data cables



6. Replace all components that were removed in preparation for component installation.

Installing an optical drive (desktop configuration)

1. Follow the procedures described in [Preparing for component installation on page 34](#) to prepare the workstation for component installation.
2. If necessary, remove the EMI filler from the front of the optical bay.
3. Install four black metric M3 guide screws into the drive (1). Spare metric M3 screws are stored on the side of the optical bay.

Figure 10-4 Installing the optical drive



4. Align the screws with the grooves in the drive bay and gently slide the drive into the bay until it snaps into place (2).
-
- △ **CAUTION:** Ensure that the optical drive is secure in the workstation chassis by pulling the drive to see if it can become disengaged. Failure to properly secure the drive can cause damage to the drive when moving the workstation.
-
5. Connect the power and drive cables to the drive and system board.

Figure 10-5 Connecting the power and data cables

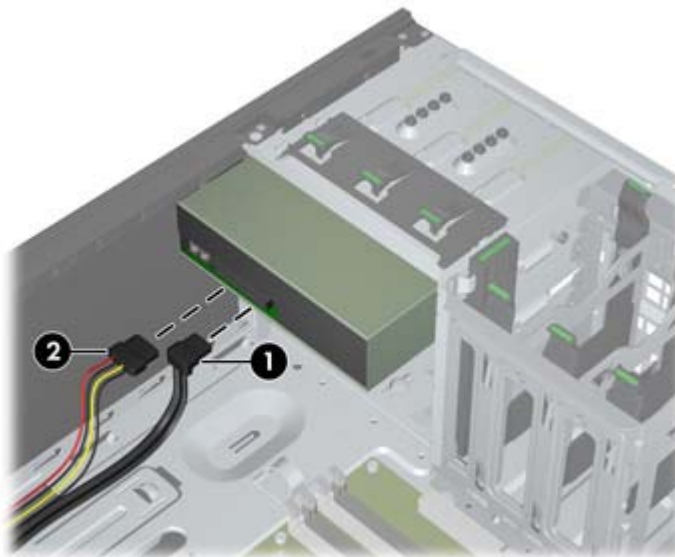

Installing an optical drive in an HP Z210 SFF Workstation

To install or re-install an optical drive in an HP Z210 SFF Workstation:

1. Follow the procedures described in [Preparing for component installation on page 34](#) to prepare the workstation for component installation.
2. Remove the front bezel.
3. If necessary remove the bezel blank.
4. Install four M3 metric guide screws in the lower holes on each side of the drive. Either re-use the screws used by your previous optical drive or use the extra HP-provided guide screws mounted on the front of the chassis.

△ **CAUTION:** Use only 5-mm long screws as guide screws. Longer screws can damage the internal components of the drive.

Figure 10-6 Installing Guide Screws in the Optical Drive



5. Position the guide screws on the drive into the J-slots in the drive bay. Then slide the drive toward the front of the computer until it locks into place.

Figure 10-7 Installing the Optical Drive

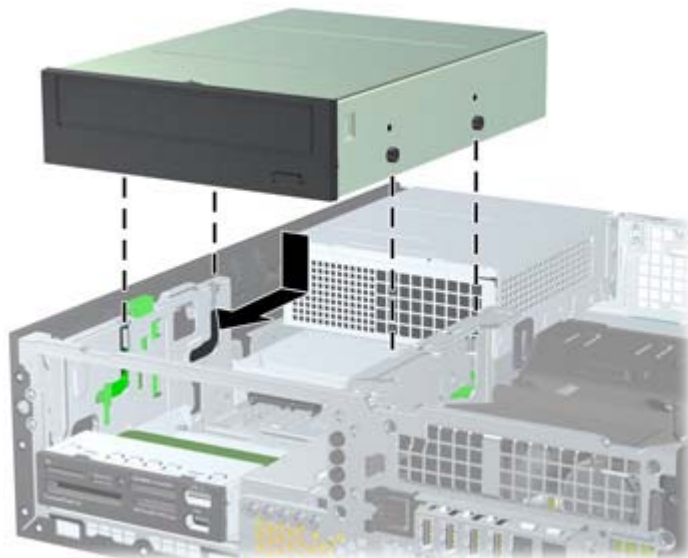

6. Rotate the drive cage to its upright position.

Figure 10-8 Rotating the Drive Cage Up

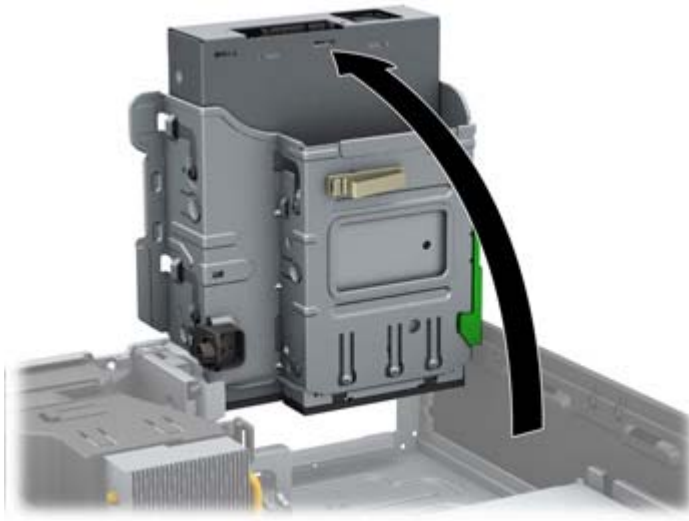

7. If a cable is not already present and connected, connect the SATA data cable to the system board connector labeled SATA1.

Route the data cable through the cable guides. Two cable guides keep the data cable from being pinched by the drive cage when raising or lowering it. One is located on the bottom side of the drive cage. The other is part of the chassis frame under the drive cage. Ensure that the data cable is routed through these guides before connecting it to the optical drive.

Figure 10-9 Routing the drive cable

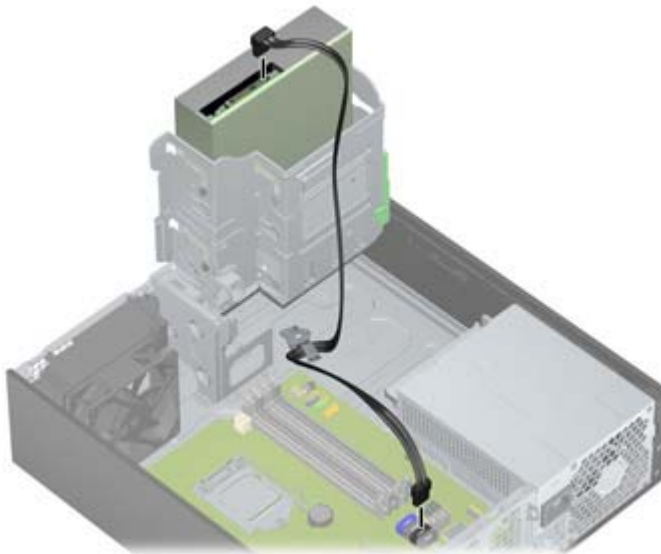

8. Connect the power cable (1) and data cable (2) to the rear of the optical drive.

Figure 10-10 Connecting the power and data cables

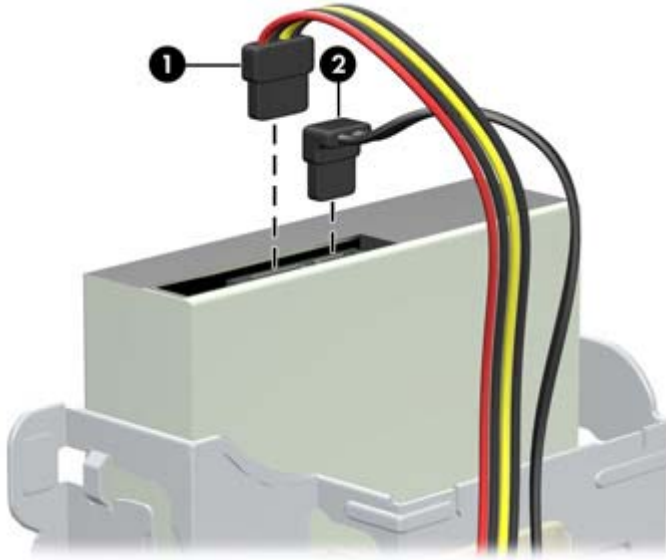

9. Carefully rotate the drive cage back down to its normal position.

△ **CAUTION:** Be careful not to pinch any cables or wires when rotating the drive cage down.

10. Replace the front bezel with any bezel blanks removed as applicable.
11. Replace all components that were removed in preparation for component installation.

Notice for Blu-ray optical drives

If you installed a Blu-ray optical drive, note the following:

Blu-ray movie playback

As Blu-ray is a new format containing new technologies, certain disc, digital connection, compatibility and/or performance issues may arise, and do not constitute defects in the product. Flawless playback on all systems is not guaranteed. In order for some Blu-ray titles to play, they may require a DVI, HDMI, or DisplayPort digital connection and your display may require HDCP support. HD-DVD movies cannot be played on this workstation.

Blu-ray movie playback compatibility and update

Playing back Blu-ray HDCP (High-bandwidth Digital Content Protection) content such as commercially distributed Blu-ray HD movies requires a fully HDCP compliant path on your computer. The HDCP technology checks compliance of each component in the path from the content on the Blu-ray disc all the way to the display monitor, including but not limited to graphic cards and monitor adapters.

HP Z Workstations have been designed with this in mind; nearly all configurations with currently available HP Professional Displays are compliant. Older HP xw4600 and xw9400 Workstation configurations may not have fully compliant paths based on the installed graphics card and display monitor; HP recommends confirming separately that you have a fully compliant system if commercial content playback is a requirement for your use. HDCP compatibility of your graphics card and monitor can be determined by checking the *QuickSpecs* at <http://www.hp.com/go/productbulletin>.

For the best HDCP performance, HP recommends that you install the latest updates:

1. Blu-ray player firmware
2. Playback application patches
3. Graphics firmware and drivers (note that the Intel HD graphics family does not support Blu-ray movie playback on Windows XP nor on Linux.)

Updates are located on the support web site for your specific product at <http://www.hp.com/support/workstations>.

Index

- B**
 - BIOS
 - Determining version 29
 - Updating 30
- D**
 - Drivers
 - Installing 26
 - Updating 26, 30
- E**
 - Expansion card
 - Installing 41
 - Slot identification 41
 - Expansion card support
 - Removing 34
 - Expansion slot cover
 - Removing 34
- F**
 - Front bezel
 - Removing 34
- G**
 - Graphics cards
 - Types 21
- H**
 - Hard drive
 - Configuration 44
 - Installing 44
 - Hardware
 - Disassembly 34
 - HP Recovery Manager 32
 - HP resources
 - Locating 1
 - Product diagnostics 5
 - Product documentation 4
 - Product information 2
 - Product support 3
 - Product updates 6
 - Web links 4
- I**
 - Installing
 - Expansion cards 41
 - Hard drive 44
 - hardware 34
 - Memory 39
 - Optical drive 53
 - PCI/PCIe cards 41
 - Installing memory 38
- M**
 - Memory
 - Installation 39
 - Memory fan
 - Removing 34
 - Microsoft Windows
 - Setting up 26
 - Transferring files 26
 - Monitors
 - Adjusting display 24
 - Configuring 23
 - Connecting 23
 - Graphics cards 21
- N**
 - Novell SLED
 - Restoring 33
 - Setting up 28
- O**
 - Operating system setup
 - Microsoft Windows 26
 - Red Hat Linux 27
 - Operating system setup; Novell SLED 28
 - Optical drive
 - Installing 53
- P**
 - Product features
 - Computer components 7, 11
 - Front panel components 9, 12
 - Rear panel components 10, 13
- R**
 - Red Hat Linux
 - Setting up 27
 - Restoring the operating system
 - Restore method 31
- S**
 - Side access panel
 - Removing 34
 - Software
 - Ordering 32
 - Support
 - Locating HP resources 1
 - System fan
 - Removing 34
- U**
 - Updating the workstation
 - First boot update 29
 - Updating drivers 30
 - Updating the BIOS 30
- W**
 - Windows Vista
 - Setting up 26
 - Windows XP
 - Setting up 26
 - Workstation
 - Preparing for component installation 34
 - Workstation components 7
 - Workstation setup
 - Accessibility 24
 - Connecting monitors 19
 - Customizing the display 24
 - Ensuring proper ventilation 14
 - Security 24
 - Setup procedures 15