



Latex 850 & 820  
SCITEX LX850 & LX820 Printers

Site preparation guide

© 2013 Hewlett-Packard Development  
Company, L.P.

1st edition

### **Legal notices**

The information contained herein is subject  
to change without notice.

The only warranties for HP Products and  
services are set forth in the express warranty  
statement accompanying such products and  
services. Nothing herein should be  
construed as constituting an additional  
warranty. HP shall not be liable for technical  
or editorial errors or omissions contained  
herein.

---

# Table of contents

<b>1 Introduction .....</b>	<b>1</b>
System configuration .....	1
Documentation .....	1
Site preparation overview .....	1
Customer responsibility .....	2
<b>2 Site preparation .....</b>	<b>5</b>
Planning for printer installation .....	5
Installation time schedule .....	5
System operation requirements .....	6
Air supply requirements (pneumatic spindle) .....	10
Room and spacial requirements .....	11
Designing the Print Production Area .....	13
Computer and networking requirements .....	15
<b>3 Shipment arrival preparation .....</b>	<b>19</b>
Unloading area .....	19
Route from unloading site to installation site .....	19
Shipment items .....	20
Tools and manpower required for installation .....	20
Moving equipment .....	20
Waste disposal .....	24



# 1 Introduction

## System configuration

Your printer is supplied almost fully assembled and ready for the simple installation procedures described in detail in the *Installation Guide*. It comes complete with printheads and a printhead cleaner roll.

## Documentation

The following manuals are provided with your printer, and can also be downloaded from <http://www.hp.com/go/LX820/manuals/> or <http://www.hp.com/go/LX850/manuals/>.

- *Site preparation guide*
- *Site preparation checklist*
- *User's guide*
- *Maintenance and troubleshooting guide*
- *Legal information*

## Site preparation overview

This guide should assist in the following planning considerations:

- Modifications to the installation area
- Site accessibility
- Emergency exits
- Planning the print production area
- Mechanical, electrical and environmental specifications
- Computer and network connectivity
- Contracting a specialist mover with a forklift and/or suitable moving equipment
- Contracting an electrician

All information in this guide is provided on the assumption that installation planners and personnel are familiar with:

- Architectural and planning requirements
- Applicable laws, regulations and standards

 **NOTE:** It is important to read the information provided in this guide thoroughly and ensure complete compliance with all installation and operation prerequisites, safety procedures, warnings, cautions, as well as local regulations.

## Customer responsibility

### Planning the site and printer environment

You are responsible for all preparations of the physical site, and you must complete the following tasks:

- Prepare the site for unloading. See [Unloading area on page 19](#).
- Make sure the route from the unloading site to the installation site meets specifications. See [Route from unloading site to installation site on page 19](#).
- Make sure you have the necessary equipment to handle the printer, as well as a specialist mover who is familiar with your site and the information provided in this guide. See [Moving equipment on page 20](#).
- Meet the requirements for second floor installations (if necessary). See [Above ground floor installation on page 22](#).
- Configure the building's electrical system used to power the printer to meet the printer's requirements and the Electrical Code requirements of the local jurisdiction of the country where the equipment is installed. A qualified electrician is required to power up the printer on the day of installation. See [Electrical configuration on page 6](#).
- Provide an adequate air supply for the pneumatic spindles. See [Air supply requirements \(pneumatic spindle\) on page 10](#).
- Meet temperature and humidity requirements and ensure proper ventilation for the printer. See [Ventilation and air conditioning on page 11](#) and [Temperature and humidity on page 11](#).
- Supply all necessary emergency equipment. See [Safety installations on page 13](#).

### RIP installation

If you have bought HP RIP software for your printer:

- You must ensure that a computer is available on which to install the RIP.
- For full functionality, you are recommended to ensure that the computer is connected to the Internet.
- You must ensure that the HP RIP software has arrived by the agreed date of printer installation.

If you have bought non-HP RIP software for your printer:

 **NOTE:** This guide does not provide information about your RIP solution.

- You must install the RIP on a suitable computer and ensure that it is fully functional by the agreed date of printer installation.
- For full functionality, you are recommended to ensure that the computer is connected to the Internet.
- You must ensure that a RIP specialist and a network specialist are present on the agreed date of printer installation.

## Networking

You are responsible for all networking requirements, and you must complete the following tasks:

 **NOTE:** In order to perform remote support, the printer must have access to the internet using the LAN connection.

- Have an adequate network ready for the day of installation. See [Computer and networking requirements on page 15](#).
- Provide a CAT-6 LAN cable to connect the printer to your LAN on the day of installation.

## Printing supplies for testing and training

You are responsible for providing the following printing supplies:

- Six ink cartridges, one for each color (no cartridges are supplied with the printer)

 **NOTE:** In addition, you are recommended to have a second set of six ink cartridges, three printheads and one maintenance kit, in case any replacements are needed.

- Compressed air supply for the pneumatic spindle. See [Air pressure supply on page 10](#).
- Some rolls of substrate for printing; preferably the substrate type that you plan to use most in future
- To test the ink collector kit (LX850 only), a roll of flexible substrate (mesh or thin textile, without liner)
- To test dual-roll printing (LX850, or LX820 with Dual Roll Kit), two rolls of 1524 mm (60 in).

## Return the site preparation checklist

The checklist must be completed and returned to your reseller or service representative a minimum of two weeks before the day of installation.

 **NOTE:** Any delays during installation that are caused by an unprepared site will be charged to the customer. Take care that your site is properly prepared to ensure a smooth and easy installation.

## Recycle the disposable ink bag and maintenance kit (printhead cleaning roller and aerosol filters)

These items require disposal according to local regulations. For further information, please refer to the MSDS document about your printer's ink, available from [http://www.hp.com/hpinfo/community/environment/productinfo/psis\\_inkjet.htm](http://www.hp.com/hpinfo/community/environment/productinfo/psis_inkjet.htm).

## Recycle the printheads

The printheads require disposal according to local regulations. For further information, please refer to the MSDS document about your printer's ink, available from [http://www.hp.com/hpinfo/community/environment/productinfo/psis\\_inkjet.htm](http://www.hp.com/hpinfo/community/environment/productinfo/psis_inkjet.htm). Within some countries covered by the 'HP Planet Partners Returns', HP is offering a recycling program. For full details of this program, please visit <http://www.hp.com/recycle/>.



## 2 Site preparation

### Planning for printer installation

This chapter covers the main topics related to efficient planning and preparation of the site. Take into consideration any structural modifications required and the time required for submission and approval of plans to the relevant local authorities. Secure temporary storage for the shipping crate prior to equipment installation may also be necessary.

**⚠ CAUTION:** All cables connected to the printer should be contained within suitable conduits; these may be overhead or channeled into the floor, as appropriate. Tripping over loose wires or cables can cause personal injury and/or damage to the equipment.

### Installation time schedule

The best method to ensure a smooth and trouble-free installation process is proper site preparation. The following time schedule estimate is based on the assumption that all system components have been delivered in proper working order and all site preparation and planning requirements have been met and completed, in accordance with the specifications provided in this guide. The installation process is divided into two phases:

**Table 2-1 Installation time schedule**

	Time to completion (LX820)	Time to completion (LX850)
Installation and System Configuration	1 full working day	1.5 full working days
Operation and Maintenance Training	2 full working days	2.5 full working days

Although the optimal time schedule requires approximately 3 or 4 full working days, it may be necessary to schedule additional time for Installation and System Configuration or Operation and Maintenance Training. Please plan ahead for any special circumstances that may occur during the installation process, and do not plan for production during installation and training.

If the RIP software is bought from HP, the training will cover the normal use of the RIP. The following aspects of RIP usage will be covered:

#### HP Scitex Onyx RIP

- Queue manager
- Configure Printer (Quickset, Device Output, Media, Page size, Properties)
- Main items of the Preflight (Printer and Media Selection, Preview and Size, Tiling Setup, Color Correction, Print)

The Media Manager will not be covered.

## HP Scitex Caldera RIP

- Server Administration (Server, Configure, connection)
- GrandRip+ (Main, Tool, settings)
- Spooler
- Image Work Directory (Image Positioning and scale setting on the page, and so on)

Profile creation will not be covered.

# System operation requirements

## Electrical configuration

**NOTE:** An electrician is required for the setup and configuration of the building electrical system used to power the printer and also for printer installation. Make sure that your electrician is appropriately certified according to local regulations and supplied with all the information regarding the electrical configuration.

Your printer requires the following electrical components to be supplied and installed by the customer, according to the Electrical Code requirements of the local jurisdiction of the country where the equipment is installed.

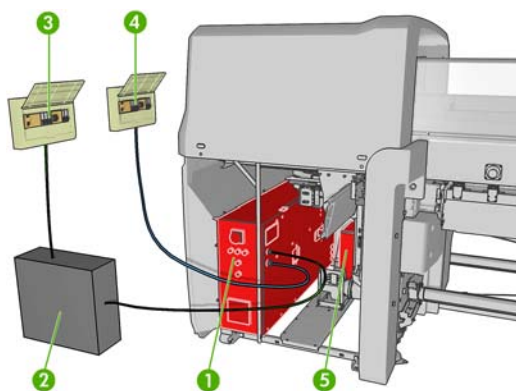

1. Printer electrical cabinet
2. Uninterruptible Power Supply (UPS) for single-phase line (recommended)
3. Power Distribution Unit (PDU) including single-phase branch circuit breaker
4. Power Distribution Unit (PDU) including three-phase branch circuit breaker
5. HP Internal Print Server computer

**NOTE:** Remember that you are required to follow the local laws, regulations, and standards that pertain to the electrical installation of your printer.

**NOTE:** The LX820 or LX850 are not supplied with a three-phase cable.

## Power distribution unit (PDU)

 **NOTE:** The PDU must be rated to meet the power requirements of the printer, and should be in accordance with the Electrical Code requirements of the local jurisdiction of the country where the equipment is installed.

The drying and curing components are powered with a three-phase line that requires a building power distribution unit (PDU).

The PDU must meet the requirements of the printer.

## Printer's three-phase line specifications

The printer electrical specifications for the three-phase line are included in the following table for both high and low voltage supplies. Use the printer electrical specifications for high or low voltage supplies according to your site.

**Table 2-2 LX820 & LX820three-phase line specifications**

	High-voltage systems	Low-voltage systems
Input voltage (line to line)	3 × 380–415 V~ (-10%+6%)	3 × 200–220 V~ (±10%)
Input frequency	50 Hz	60 Hz <sup>1</sup>
Power consumption	15 kW	15 kW
Maximum load current (per phase)	30 A	50 A

<sup>1</sup> Japan may have input frequencies of 50 Hz or 60 Hz

 **CAUTION:** Ensure that input voltage is within the printer's rated voltage range.

The printer requires three-phase power. Three-phase power provides a more efficient means of supplying large electrical loads than single-phase power, which is common in offices and homes. If only single-phase power is supplied to your facility, purchase a converter to adapt your building's single-phase power to three-phase power and have it installed by a qualified electrician prior to the printer's installation date. Ensure that converter's output specifications meets the printer's three-phase line requirements as shown in the table above (three-phase line specifications).

## Printer's single-phase line specifications

The printer electrical specifications for the single-phase line are included in the following table for both high- and low-voltage supplies. Use the printer electrical specifications for high- or low-voltage supplies according to your site.

**Table 2-3 Printer's single-phase line specifications**

	High-voltage systems	Low-voltage systems
Input voltage (line to neutral)	200–240 V~ (-10%+6%)	115–127 V~ (±10%) (Japan 200 V~)
Input frequency	50 Hz	60 Hz <sup>1</sup>
Power consumption	1 kW	1 kW
Maximum load current (per phase)	10 A	10 A

<sup>1</sup> Japan may have input frequencies of 50 Hz or 60 Hz

## Uninterruptible power supply (UPS) for single-phase line (optional)

 **NOTE:** The UPS must be rated to meet the power requirements of the printer, and should be in accordance with the wiring standards of the country of installation.

The electronic control components and HP Internal Print Server are powered with a single-phase line that can be used with an Uninterruptible Power Supply (UPS). HP highly recommends that you use a UPS.

## Circuit breakers (required)

 **NOTE:** The circuit breakers must meet the requirements of the printer and should be in accordance with the Electrical Code requirements of the local jurisdiction of the country where the equipment is installed.

The LX800 printer requires two branch circuit breakers: one for the single-phase line and one for the three-phase line.

**Table 2-4 LX820 & LX850 three-phase circuit breaker specifications**

	High-voltage systems	Low-voltage systems
Input voltage (line to line)	3 × 380–415 V~ (-10%+6%)	3 × 200–220 V~ (±10%)
Input frequency	50 Hz	60 Hz
Three-phase branch circuit breaker	3 poles, 40 A	3 poles, 63 A

**Table 2-5 LX820 & LX850 single-phase circuit breaker specifications**

	High-voltage systems	Low-voltage systems
Input voltage (line to line)	200–240 V~ (-10%+6%)	115–127 V~ (±10%) (Japan 200 V~)
Input frequency	50 Hz	60 Hz
Single-phase branch circuit breaker	2 poles, 16/20 A	2 poles, 16/20 A

 **WARNING!** Ensure that the printer's built-in three-phase circuit breaker or ground fault circuit interrupter operates in the case of a current leakage fault to the product chassis, even when an isolation device (such as an isolating transformer) will be used to supply power to the printer.

**WARNING!** Ensure that mains fault current is adequate for proper operation of the supplementary circuit breakers incorporated in the printer (10 kA rated interrupting capacity).

## Power cables

A three-phase power cable is not provided with the printer. The cables that you use must meet the following minimum specifications.

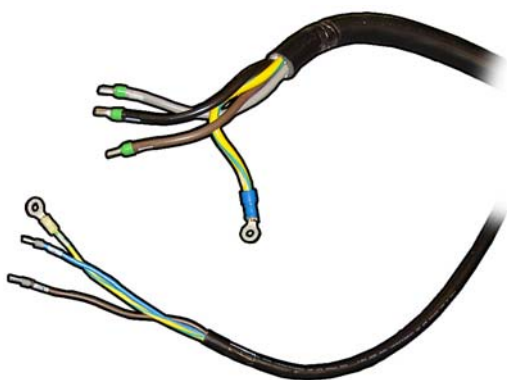

**Table 2-6 Cable specifications**

	Three-phase line	Single-phase line
Configuration	4 wires, L1/L2/L3/PE	3 wires, L/N/PE
Wire	Strained Cu, AWG6, 13 mm <sup>2</sup>	Strained Cu, AWG12, 4 mm <sup>2</sup>
Maximum external diameter	30 mm (1.18 in)	–

PE connections should be made through an M6 stub.

The power cable can be routed from above the right of the top cover; it can be routed from the ceiling.

## Powerline disturbances

Reliable operation of your printer depends on the availability of relatively noise-free AC power.

- In order to ensure optimum performance and reliability, your printer should be protected from variations in line voltage, which are common to production printing environments. Lighting, line faults, or the power switching commonly found in machinery in factory environments can generate line transients that far exceed the peak value of the applied voltage. If not reduced, these micro-second pulses can disrupt system operation.
- If the power line supplying the installation site is a public low voltage line shared with other users, the power line impedance at 50 Hz must be less than 34 mΩ, to comply with European regulations. If other users on the same power line report any flickering of incandescent light bulbs, contact your electricity supplier to verify that the power network has an impedance lower than the one specified above.
- It is recommended to include overvoltage (OVP) and transient protection on the power supply to the printer.
- All electrical noise generating equipment, like fans, fluorescent lighting, and air-conditioning systems, should be kept separate from the power source used for your printer.
- The heating and curing lamps are powered by the three-phase AC lines. For optimal printer operation, the three-phase system must have a maximum variation equal to or lower than 3% voltage unbalance, and 5% voltage sag. If the maximum variation is not within this range, print quality and printer operation may be affected. Contact your electricity supplier to remedy any voltage unbalance or sag.

To avoid certain specific system errors in some cases, such as 15.8:10 or 16.8:10, you are recommended to have no more than 10 V variation in the three-phase line (line to line).

## Grounding

The printer must be connected to a good quality, dedicated ground line in order to avoid electrical risk. Please note your obligation to comply with the National Electrotechnical Code (NEC) in the county of installation.

The following grounding tasks must be fulfilled to meet the site preparation requirements:

- Grounding wires should be insulated and at least equal in size to the phase conductors.
- Ground impedance must be less than 0.5  $\Omega$ .
- The installation of a single point and dedicated ground.
- Power stabilizer equipment that is supplied by three uninterrupted phase wires and one uninterrupted copper ground wire from the main building service panel. These should run in the same conduit and should be at least equal in size to the phase wires.

## Air supply requirements (pneumatic spindle)

### Air pressure supply

The pneumatic spindle requires an air compressor or pressurized air line that must be provided by the customer.

 **TIP:** HP recommends that you use an air compressor with a pressure gauge that measures in bars.

**Table 2-7 Air supply specifications**

	Specification
Air pressure	5.5 bar (80 psi) (required)
Minimum airflow	30 liters/minute (1.06 cubic feet/minute)
Lubricator (not required)	Not recommended
Air filter (recommended)	Recommendation: 5 $\mu\text{m}$ , auto-drain, 99.97% coalescing efficiency
Regulator (required)	Regulator with pressure gauge

### Pneumatic connector

The printer comes with an air gun that you must attach to your air supply. In order to connect your air supply to the air gun, you must meet the following requirements:

- 6.35 mm (0.25 in) female connector, BSP or NPT thread
- PTFE tape to secure the connection and prevent air leaks

# Room and spacial requirements

## Temperature and humidity

The temperature, humidity, and temperature gradient during operation and during storage must be kept within the standard ranges to ensure the correct operation of the printer. Failure to keep these environmental conditions within the standard ranges may cause image quality problems or damage sensitive electronic components.

**Table 2-8 Printer environmental specifications**

	Temperature range	Humidity range	Temperature gradient
Operating for optimal print quality	20 to 25°C (68 to 77°F)	40 to 60% Relative Humidity	10°C/h (50°F/h) or less
Operating for standard printing	15 to 30°C (59 to 86°F)	20 to 70% Relative Humidity	10°C/h (50°F/h) or less
Not operating (in transport or storage), ink in tubes	5 to 55°C (41 to 131°F)	90% Relative Humidity at 55°C (131°F)	10°C/h (50°F/h) or less
Not operating (in transport or storage), no ink in tubes	-25 to 55°C (-13 to 131°F)	90% Relative Humidity at 55°C (131°F)	10°C/h (50°F/h) or less

Maximum operating altitude: 3000 m (10000 ft)

In addition to controlling the temperature, humidity, and temperature gradient, there are other environmental conditions that must be met during site preparation.

- Do not install the printer where it will be exposed to direct sunlight or a strong light source.
- Do not install the printer in a dusty environment. Remove any accumulated dust before moving the printer into the area.

## Ventilation and air conditioning

As with all equipment installations, to maintain ambient comfort levels, air conditioning or ventilation in the work area should take into account that the printer produces heat. Specifically, the printer's power dissipation is 15 KW (51 KBTU/h).

Air conditioning and ventilation should meet with local environmental, health and safety (EHS) guidelines and regulations. Consult your usual air conditioning or EHS specialist for advice on the appropriate measures for your location.

For a more prescriptive approach to adequate ventilation, you could refer to the ANSI/ASHRAE (American Society of Heating, Refrigerating and Air-Conditioning Engineers) 62.1-2007 *Ventilation for Acceptable Indoor Air Quality*. As an example, a minimum exhaust rate of 2.5 L/s.m<sup>2</sup> (0.5 cfm/ft<sup>2</sup>) of fresh make up air for "copy, printing rooms" is specified.

 **NOTE:** The ventilation and air conditioning units should not blow air directly onto the printer.

**NOTE:** You are recommended to maintain a positive airflow in the print production room to help prevent dust from entering the room.

## Printing on porous substrates—visible vapor

Under some conditions of ambient temperature and relative humidity, visible vapors may be produced when printing with water-based HP Latex inks, especially when printing on porous substrates.

In high-production environments, it is recommended that supplementary ventilation be considered to maintain comfort levels and prevent condensation, especially when printing in a confined area on porous substrates.

Special ventilation is not required to meet US OSHA requirements on occupational exposure to VOCs from HP Latex inks. Special ventilation-equipment installation is at the discretion of the customer—no specific HP recommendation is intended for special ventilation. Customers should consult state and local requirements and regulations.

## Load bearing

The load-bearing characteristics of the floor in the print production area must be sufficient to withstand the weight of your printer. To calculate the load bearing characteristics of the print production floor, you must consult a structural engineer.

<b>LX820 &amp; LX850</b>	
Printer weight without substrate	1100 kg (2425 lb)
Load on each foot	367 kg (809 lb)

Your printer has four wheels used to move the printer and three feet that must be lowered to touch the ground and support the printer. The following diagram shows where the feet and wheels touch the ground, in case you need extra reinforcements.

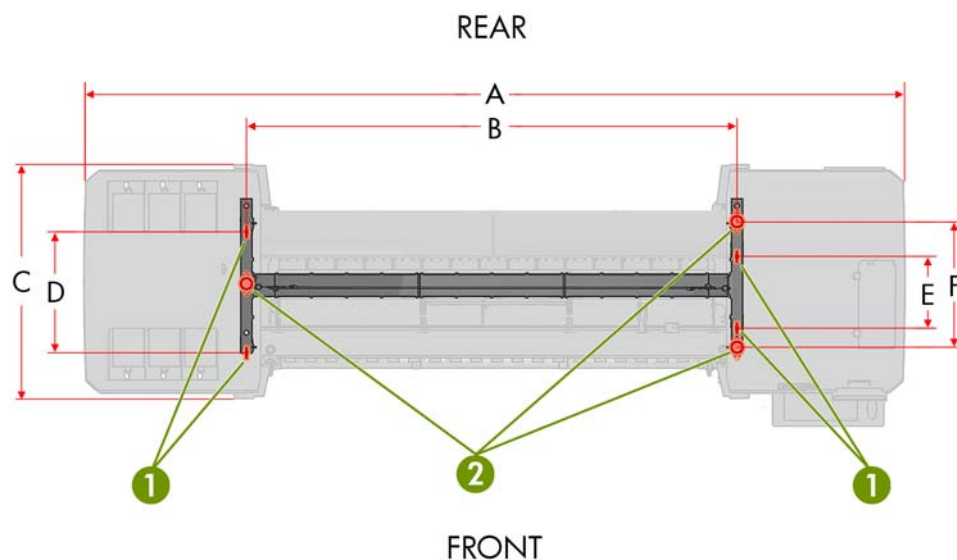

In the table below, the number or letter in the left column corresponds to the diagram above.

<b>LX820 &amp; LX850</b>	
1	Wheels
2	Feet



LX820 & LX850	
A	5.718 m (225.11 in)
B	3.650 m (143.69 in)
C	1.485 m (58.46 in)
D	762 mm (30 in)
E	451 mm (17.75 in)
F	782 mm (30.79 in)

## Floor surface

The floor surface should have the following characteristics:

- Solid, smooth, and level
- No holes or indentations
- Static-free surface (no carpet)
- Easy to clean
- Durable
- Free from strong vibrations

## Lighting

Whenever your printer is in operation, the print production area should be well lit to provide the operator with optimal conditions for checking the color and alignment during print production. If there is not enough natural light, artificial lighting will be required.

# Designing the Print Production Area

## Safety installations

### Fire fighting equipment

You must provide two fire extinguishers for the site. Make sure the extinguishers are placed where they are easily accessible in case of fire.

- A fire extinguisher certified for electrical fires must be in the print production area.
- A fire extinguisher must be placed in the substrate storage area, due to the large amount of solid combustibles (substrates).

Emergency exits and first aid stations should also be considered.

## Optimal room layout

Your printer requires enough space to perform the following tasks:

- Print
- Use the HP Internal Print Server
- Replace a substrate roll
- Service the printer or replace printer components
- Ensure the printer is well ventilated

Your printer has the following dimensions:

**Table 2-9 LX820 & LX850 physical specifications**

	Doors closed <sup>1</sup>	Doors open <sup>2</sup>
Width	5.74 m (226.07 in)	6.26 m (246.53 in)
Depth	1.66 m (65.34 in)	1.80 m (71.18 in)
Height	1.65 m (65.08 in)	2.03 m (80.08 in)

<sup>1</sup> Includes all accessories installed, including the HP Internal Print Server and keyboard platform

<sup>2</sup> Front door open, printhead access door open, printhead cleaning assembly pulled out, substrate loaded

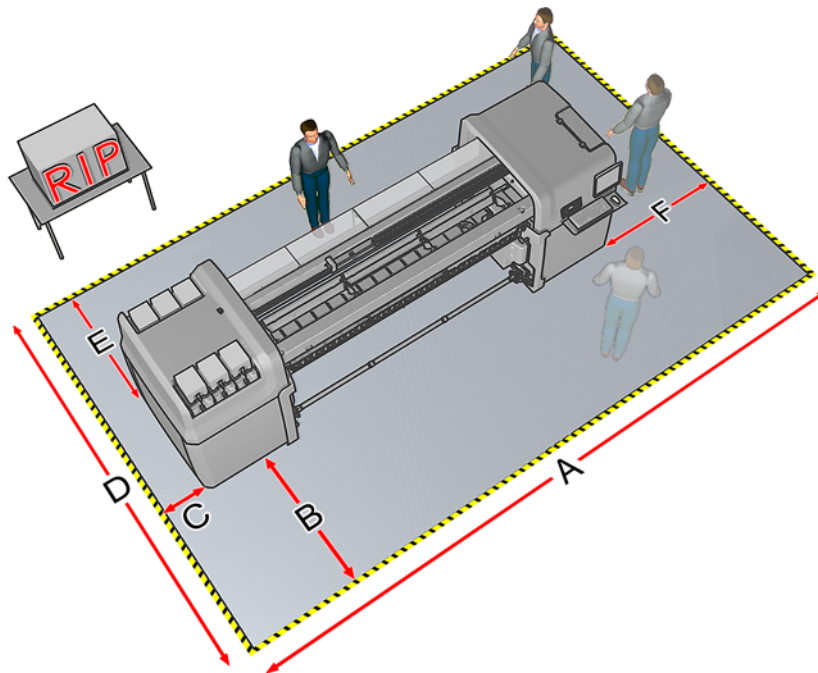

In the table below, the number in the left column corresponds to the room layout illustration above.

Measurement	
A	8 m (26 ft 3 in)
B	1.5 m (5 ft)
C	0.6 m (2 ft) minimum
D	4 m (13 ft 2 in)

Measurement	
E	1.5 m (5 ft)
F	1.5 m (5 ft)

The ceiling of the room should be at a minimum height of 2.5 m (8 ft 3 in) above the floor.

**⚠ WARNING!** The zone surrounding the printer should be considered a restricted access area and signaled accordingly. Only trained personnel should be operating within this area.

## Storage area for materials

When planning a storage area for materials used with the printer, thought should not only be given to safety and convenience, but also to the fact that if inks and substrates are not stored in the appropriate temperature and humidity conditions, print results may be adversely affected.

The storage area should be of sufficient size to accommodate adequate stocks of substrate rolls and inks. The storage area should be located near the print production area to minimize the lifting and maneuvering of heavy materials.

The storage area should have a covered roof. It should be dry, well ventilated and able to provide protection from direct light. It is important that temperature and humidity are maintained within values specified for each paper type.

## Storage conditions for substrate rolls

Keep substrate rolls in their sealed wrapping material while they are placed in storage.

Store substrate rolls vertically to avoid the migration of plasticizers in some materials.

Move substrates from the storage area to the print production area at least 24 hours before use, so that they can reach the required moistness and operating temperature.

**📝 NOTE:** HP substrate rolls have a 12 month warranty when the substrate rolls are stored under optimal conditions. The warranty term varies depending upon the material and the manufacturer.

# Computer and networking requirements

## LAN and switch requirements

To use CallMe@HP for remote support, you need one of the following:

- A direct, open Internet connection
- An Internet connection over a network allowing open traffic on ports 80 or 443
- An Internet connection over a network allowing traffic on ports 80 or 443 through a proxy

HP provides the following LAN and switch related system components:

## HP provided LAN/switch components

- 1-Gigabit Ethernet switch (must be set to autosense) and power cord
- HP Internal Print Server
  - CPU and power cord
  - Monitor and power cord
  - Keyboard
  - Mouse
  - Windows Vista
  - HP Internal Print Server software
- Two 1-Gb Ethernet cables

## Customer provided LAN/switch components

- Ethernet LAN (minimum 100Mb/s, optimum 1Gb/s)
- RIP station and software
- CAT-6 LAN cable long enough to connect the printer to the network



**NOTE:** The port of the hub or switch to which the printer is connected must be configured as **autosense**. If it is set to any other protocol (such as half-duplex), there will be no communication.

## RIP requirements

There are two RIPs offered by HP that may be used with the printer:

- HP Scitex Onyx RIP (Production House): product number CQ756A
- HP Scitex Caldera RIP (GrandRIP+): product number CQ755A

The software and hardware requirements of these RIPs are as follows.

### HP Scitex Onyx X10 RIP (minimum configuration)

- Processor:
  - Intel Core 2 Duo, Pentium IV 3GHz
  - AMD Phenom, Athlon X2, Athlon 64 / Opteron 2GHz (with multiple RIPs, use a dual-core CPU or two single-core CPUs)
- Memory: 2GB RAM per CPU
- Hard disk drives: Two 80GB drives (SATA recommended)
- Monitor: 1280 × 1024 pixels, 16-bit color
- USB port for security key

- DVD-ROM drive
- Operating system:
  - Windows XP Pro 32-bit or 64-bit with the latest service pack
  - Windows Vista Business or Enterprise 32-bit and 64-bit with the latest service pack
  - Windows 7 Business or Enterprise 32-bit and 64-bit with the latest service pack

### HP Scitex Onyx X10 RIP (optimal configuration)

- Processor: Intel Core i7 3.2GHz processor
- Memory: 6GB DDR3 (3 × 2GB) 1066MHz fully-buffered ECC RAM
- Hard disk drives: Four 74GB, 10,000 RPM SATA drives

 **NOTE:** One for OS and application, one for temporary data processing (Bandhome), one for output device 1, one for output device 2. Add additional drives for additional output devices.

- Monitor: 1280 × 1024 pixels, 16-bit color
- USB port for security key
- DVD-ROM drive
- Operating system:
  - Windows XP Pro 64-bit with the latest service pack
  - Windows Vista Business or Enterprise 64-bit with the latest service pack
  - Windows 7 Business or Enterprise 32-bit and 64-bit with the latest service pack

For further details of Onyx configuration, see <http://www.onyxgfx.com/index.php?area=viewinfo&action=kbase&id=50170000000OmCAAA0>.

### HP Scitex Caldera 8.0.1 RIP (minimum configuration)

- Processor: Single- or dual-core 2GHz
- Memory: Minimum 1GB, recommended 2 or 4GB
- Hard disk drive: 250GB
- Monitor: 1280 × 1024 pixels
- Operating system: Mac OS X 10.4.11, 10.5 or 10.6; or a Linux operating system

For further details of Caldera configuration, see:

- [http://www.caldera.eu/en/support.php?page=operating\\_system](http://www.caldera.eu/en/support.php?page=operating_system)
- [http://www.caldera.eu/docs/Datasheet\\_GrandRIP+\\_UK.pdf](http://www.caldera.eu/docs/Datasheet_GrandRIP+_UK.pdf)

## External color profiling

In order to build color profiles for your printer, an external color sensor is needed. Make sure to choose an external color sensor that is compatible with your RIP.

During the installation training, it is the customer's responsibility to have a RIP specialist available to create color profiles.

# 3 Shipment arrival preparation

## Unloading area

A suitable unloading area will need to be designated that will be easily accessible to the delivery truck. This will require sufficient space to unload the large crate in which your printer is shipped. When planning this area, consider the following:

- Height and width of entrance to unloading area
- Ramps used to access the unloading area
- Height and size of unloading dock (if applicable)

## Route from unloading site to installation site

The route between the unloading area of the printer and the installation site, including any corridors and doorways through which the printer must be transported, is important to proper site preparation and must be planned before the arrival of the printer. This pathway must be clear when the printer arrives. Regarding ground floor room access, transport of the bulky printer components requires:

**Table 3-1 Doorway, ceiling and corridor specifications**

	Printer	Crate
Minimum doorway width	1.85 m (72.9 in)	2 m (78.8 in)
Minimum ceiling height	2 m (78.8 in)	2.5 m (98.5 in)
Minimum corridor width	1.85 m (72.9 in)	2 m (78.8 in)
Minimum corridor width for a 90° turn	3.2 m (126 in)	3.65 m (144 in)

**⚠ WARNING!** After being removed from the crate, the printer cannot be moved up or down a ramp. If you need to move the printer up or down a ramp, you can do it only when the printer is still attached to the crate.

**💡 TIP:** Decide when you will remove the printer from the crate. It is recommended that the shipping crate be unpacked as close as possible to the printer's final destination. Usually, the printer is removed from the crate before moving it to the installation site.

Disassembling the crate requires an electric screwdriver that must be plugged into a power outlet, so make sure that a power outlet is available near the site where you plan to disassemble the crate.

# Shipment items

All printer components will arrive in a single crate. The dimensions and weight of the crate and printer are as follows:

**Table 3-2 LX850/LX820 printer and crate physical specifications**

	Length	Width	Height	Weight
Crate	5.86 m (230.7 in)	1.73 m (68.11 in)	2.16 m (85.04 in)	1900 kg (4189 lb)
Printer	5.718 m (225.11 in)	1.6440 m (64.72 in)	1.6592 m (65.32 in)	1100 kg (2425 lb)

## Tools and manpower required for installation

The installation process requires two capable persons, usually the installer and the operator.

Check with the installation specialist before delivery to make sure you do not have to supply any tools.

## Moving equipment

### Ground floor installation

**CAUTION:** Unloading and moving the printer and all system components is the customer's responsibility and not HP's. Failure to provide the required moving and lifting apparatus could result in personal injury or damage the printer during installation.

The use of specialist moving and lifting equipment is required during the unloading, unpacking and installation of your printer.

Advanced booking for the services of a machinery moving contractor/rigger must be made. It is important to confirm that the hired moving specialist and moving equipment will be available when the printer is delivered.

The following equipment is recommended:

- Wide, heavy-duty forklift (required)

**Table 3-3 Forklift specifications**

	Weight	Fork length	Distance between forks
Forklift for LX820 & LX850	3500 kg (7716 lb)	2 m (78.74 in)	800 mm (31.5 in)



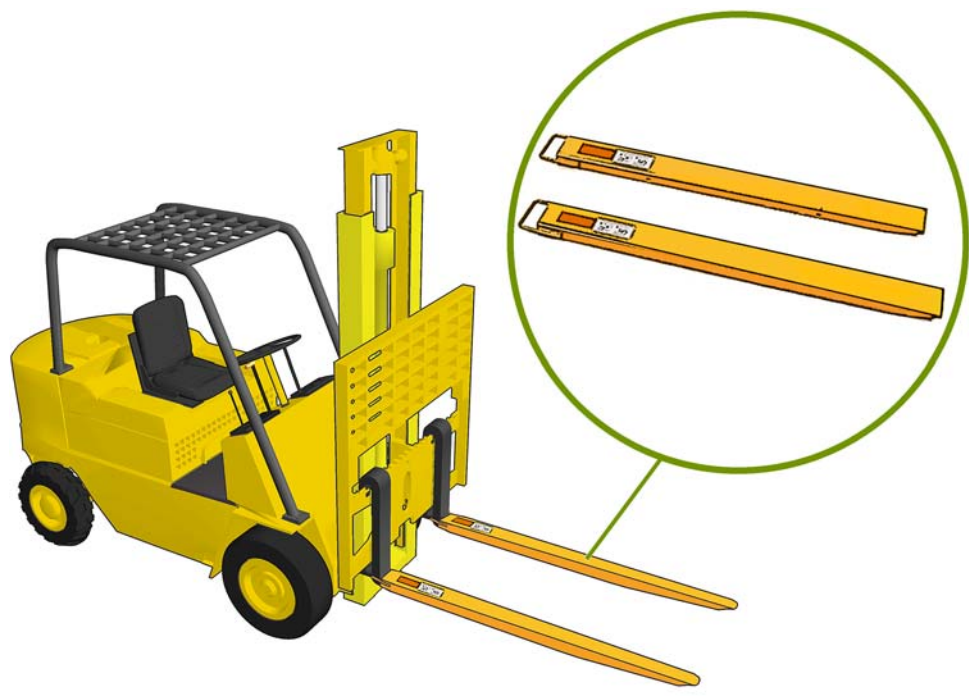

- Two skates to move the crate (optional)

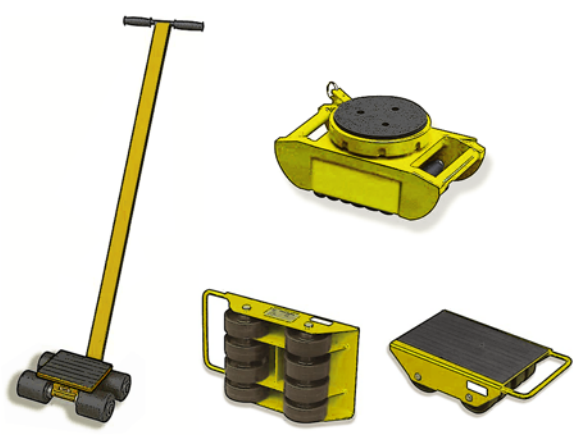

- Electric pallet jack (optional)

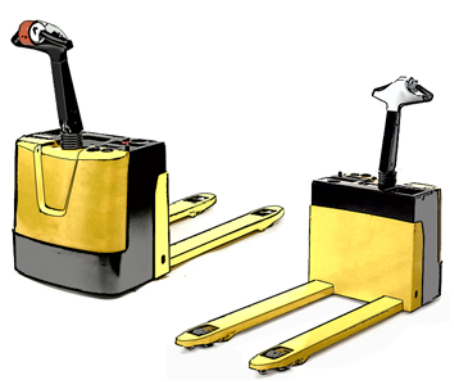

- Manual pallet jack (optional)

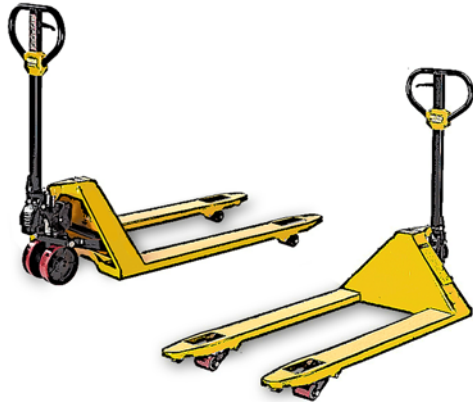

## Above ground floor installation

**CAUTION:** Unloading and moving the printer and all system components is the responsibility of the customer and not HP. Failure to provide the required moving and lifting equipment could result in personal injury or damage the printer during installation.

Above ground floor installation requires a crane and special lifting gear in addition to the standard moving equipment. At some installation sites, it may be necessary to remove the crate packaging before lifting the printer with the crane. The following section describes the equipment and configurations needed to lift the printer with a crane.

### Crane attachment to lift the printer (without a spreader beam)

The printer is lifted using the same guides used to lift the printer with a forklift. Two lifting bars are inserted into the forklift guides and connected with lifting cables to the crane.

**CAUTION:** When lifting the printer with a crane, extra caution should be taken to ensure that the cables do not apply pressure to the scan beam or any other printer component.

**CAUTION:** This attachment is used if you are removing the crate packaging before lifting the printer and must meet the following specifications. Failure to meet the following specifications could damage the printer.

**Table 3-4 Crane specifications (without a spreader beam)**

	Maximum width of the two lifting bars	Maximum height of the two lifting bars	Minimum length of the two lifting bars	Minimum length of the lifting cables
Crane attachment (option 1)	195 mm (7.7 in)	80 mm (3.1 in)	1.5 m (59.1 in)	6.5 m (255.9 in)
Crane attachment (option 2)	195 mm (7.7 in)	80 mm (3.1 in)	2 m (78.74 in)	6 m (236.2 in)

The following graphic illustrates the dimensions of the lifting bars and cables.

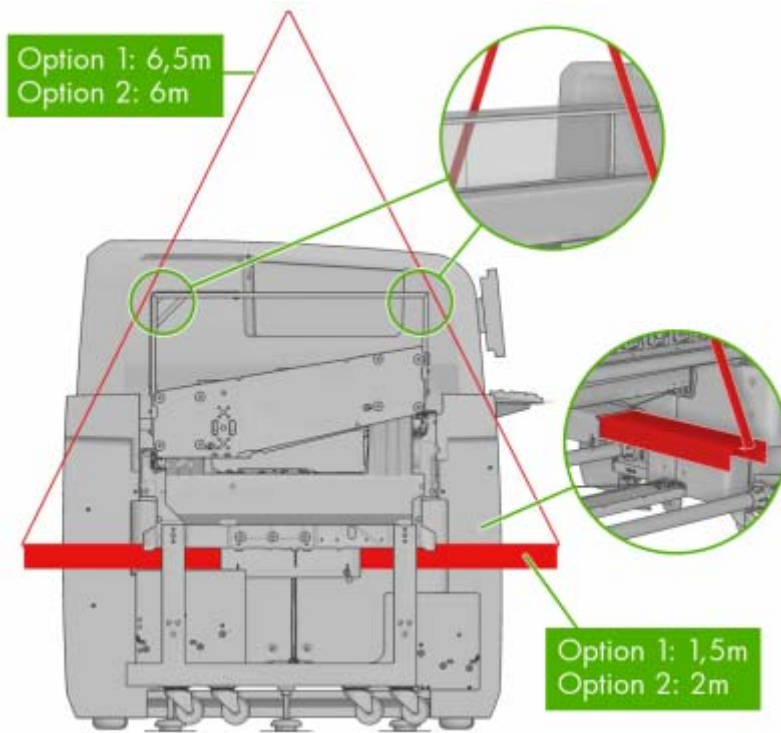

The following graphic illustrates how to lift the printer with a crane (without a spreader beam).

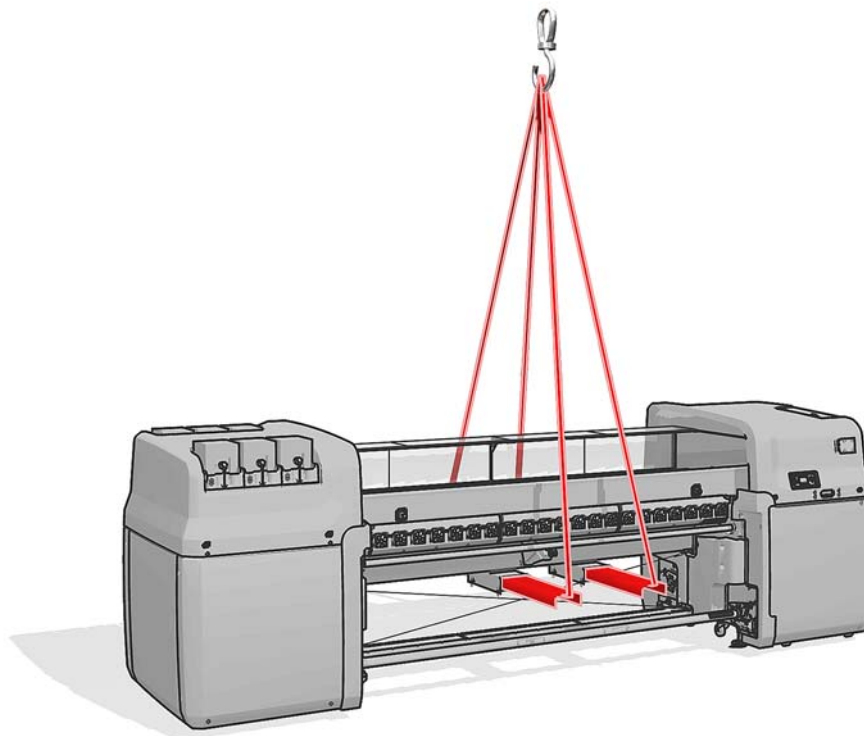

### Crane attachment to lift the printer with a spreader beam

When you lift the printer with a spreader beam, the lifting bars and spreader beam must be long enough so that the lift cables do not touch the printer. The following graphic illustrates how to lift the printer with a spreader beam.

**CAUTION:** When lifting the printer with a crane, extra caution should be taken to ensure that the cables do not apply pressure to the scan beam or any other printer component.

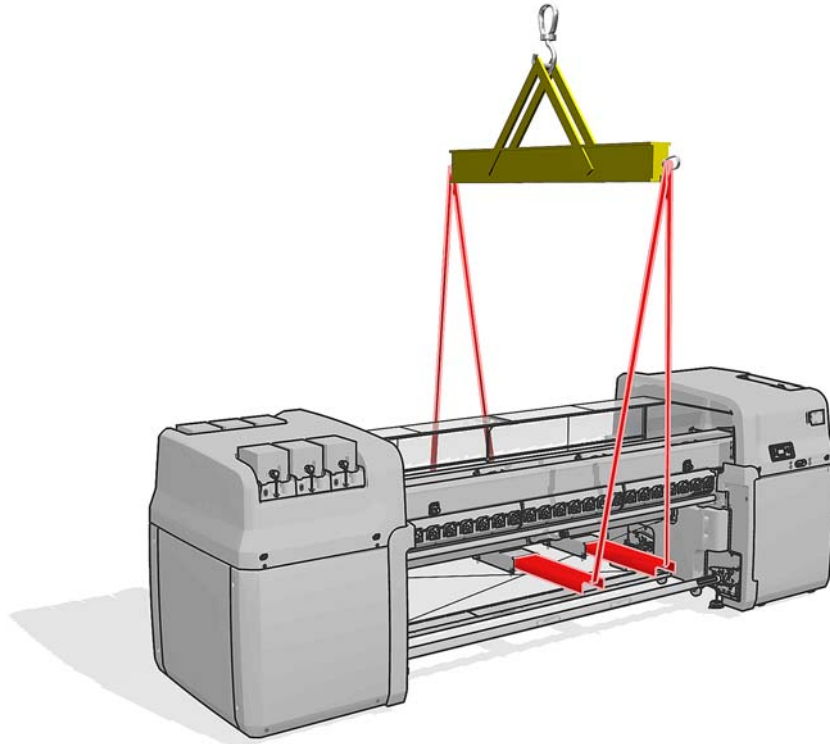

## Waste disposal

You must dispose of the crate and packaging material that comes with the printer. Most of the waste will be wood materials.