



ENVY¹⁷

GETTING STARTED

HP ENVY¹⁷ Getting Started

© Copyright 2011 Hewlett-Packard
Development Company, L.P.

AMD is a trademark of Advanced Micro
Devices, Inc. Microsoft and Windows are U.S.
registered trademarks of Microsoft Corporation.
Bluetooth is a trademark owned by its proprietor
and used by Hewlett-Packard Company under
license. Intel is a trademark of Intel Corporation
in the U.S. and other countries. SD Logo is a
trademark of its proprietor.

The information contained herein is subject to
change without notice. The only warranties for
HP products and services are set forth in the
express warranty statements accompanying
such products and services. Nothing herein
should be construed as constituting an
additional warranty. HP shall not be liable for
technical or editorial errors or omissions
contained herein.

First Edition: May 2011

Document Part Number: 651673-001

Product notice

This guide describes features that are common
to most models. Some features may not be
available on your computer.

Software terms

By installing, copying, downloading, or otherwise using any software product preinstalled on this computer, you agree to be bound by the terms of the HP End User License Agreement (EULA). If you do not accept these license terms, your sole remedy is to return the entire unused product (hardware and software) within 14 days for a refund subject to the refund policy of your place of purchase.

For any further information or for requesting a full refund of the computer, please contact your local point of sale (the seller).

User Guides

HP is committed to reducing the environmental impact of our products. As part of this effort, we provide user guides and learning centers on your computer hard drive in Help and Support. Additional support and updates to the user guides are available on the Web.

Safety warning notice

 **WARNING!** To reduce the possibility of heat-related injuries or of overheating the computer, do not place the computer directly on your lap or obstruct the computer air vents. Use the computer only on a hard, flat surface. Do not allow another hard surface, such as an adjoining optional printer, or a soft surface, such as pillows or rugs or clothing, to block airflow. Also, do not allow the AC adapter to contact the skin or a soft surface, such as pillows or rugs or clothing, during operation. The computer and the AC adapter comply with the user-accessible surface temperature limits defined by the International Standard for Safety of Information Technology Equipment (IEC 60950).

Table of contents

1 Welcome	1
What's new	2
HP CoolSense	2
Intel Wireless Display	2
Switching between graphics modes	2
Beats Audio	3
AMD Eyefinity Multi-Display technology	4
Example display configuration for single large surface (SLS)	4
Switching the screen image	4
Using the AMD Catalyst Control Center	5
Finding information	5
2 Getting to know your computer	8
Top	8
TouchPad	8
Lights	9
Button	10
Keys	11
Front	12
Right-side	13
Left-side	15
Display	17
Bottom	19
3 Networking	21
Using an Internet service provider (ISP)	21
Connecting to a wireless network	22
Connecting to an existing WLAN	22
Setting up a new WLAN network	22
Configuring a wireless router	23

Protecting your WLAN	23
4 Keyboard and pointing devices	24
Using the keyboard	24
Using the action keys	24
Using the hotkeys	26
Using the keypad	27
Using the integrated numeric keypad	27
Using pointing devices	27
Setting pointing device preferences	27
Using the TouchPad	27
Turning the TouchPad off and on	28
Navigating	29
Selecting	29
Using TouchPad gestures	30
Scrolling	31
Pinching/Zooming	31
Rotating	32
Flicking	33
5 Maintenance	34
Removing or inserting the battery	34
Removing the battery	34
Inserting the battery	35
Replacing or upgrading the hard drive	36
Removing the hard drive	36
Installing a hard drive	38
Adding or replacing memory modules	40
Cleaning your computer	47
Cleaning the display	47
Cleaning the TouchPad and keyboard	47
Updating programs and drivers	47

6 Backup and recovery	48
Restore	48
Creating restore media	48
Performing a system restore	49
Restoring using the dedicated recovery partition (select models only)	50
Restoring using the restore media	50
Changing the computer boot order	51
Backing up and recovering your information	51
Using Windows Backup and Restore	53
Using Windows system restore points	53
When to create restore points	53
Create a system restore point	54
Restore to a previous date and time	54
7 Customer support	55
Contacting customer support	55
Labels	55
8 Specifications	57
Input power	57
DC plug of external HP power supply	57
Operating environment	58
Appendix A RAID 0 (select models only)	59
Disabling RAID 0	59
Index	61

1 Welcome

After you set up and register the computer, it is important to take the following steps:

- **Connect to the Internet**—Set up your wired or wireless network so that you can connect to the Internet. For more information, refer to [Networking on page 21](#).
- **Update your antivirus software**—Protect your computer from damage caused by viruses. The software is preinstalled on the computer and includes a limited subscription for free updates. For more information, refer to the *HP Notebook Reference Guide*.
- **Get to know your computer**—Learn about your computer features. Refer to [Getting to know your computer on page 8](#) and [Keyboard and pointing devices on page 24](#) for additional information.
- **Create recovery discs or a recovery flash drive**—Recover the operating system and software to factory settings in case of system instability or failure. For instructions, refer to [Backup and recovery on page 48](#).
- **Find installed software**—Access a list of the software preinstalled on the computer. Select **Start > All Programs**. For details about using the software included with the computer, refer to the software manufacturer's instructions, which may be provided with the software or on the manufacturer's Web site.

What's new

HP CoolSense

HP CoolSense  gives you more control over your computer's thermal settings through the use of predefined modes that emphasize computer performance, temperature, and fan speed and noise.

- **On**—Configures the thermal settings to avoid temperature increases and makes the computer feel cooler to the touch.
- **Off**—With CoolSense turned off, your computer will operate at peak performance, but this setting may result in higher temperatures than in On mode.
- **Auto** (default setting)—Automatically detects whether the computer is stationary or mobile, and optimizes the thermal settings to match your usage environment. When the computer is stationary, HP CoolSense prioritizes performance and is set to Off mode. When the computer is mobile, HP CoolSense prioritizes temperature and is set to On mode.

To change the cooling preferences, follow these steps:

1. Select **Start > All Programs > HP > HP CoolSense**.
2. Select a cooling mode.

Intel Wireless Display

Intel® Wireless Display allows you to share your computer content wirelessly on your TV. To experience wireless display, a wireless third-party TV adapter (purchased separately) is required. Content that asserts output protection, such as Blu-ray discs, will not play on Intel Wireless Display. For details about using the wireless adapter, refer to the device manufacturer's instructions.



NOTE: Be sure that wireless is enabled on your computer before using the wireless display.

Switching between graphics modes

The computer is equipped with switchable graphics and has two modes for processing graphics. When you switch from AC power to battery power, the computer can switch from using the high-performance mode to using the power-saving mode to conserve battery life. Similarly, when you switch from battery power to AC power, the computer can switch back to the high-performance mode.



NOTE: In some instances, in order to optimize performance of the computer, the system does not allow you to switch modes, or it may prompt you to switch. It may also be necessary to close all programs before switching.

When you switch between AC and battery power, you are notified that the computer is about to switch graphics modes. If you prefer, you can choose to

continue using the same graphics mode. While the computer switches modes, the screen goes blank for a few seconds. When the switch is complete, a notification appears in the notification area, and the screen image reappears.

Beats Audio



Beats™ Audio is an enhanced audio profile that provides a deep, controlled bass while maintaining a clear sound. Beats Audio is enabled by default.

- ▲ To increase or decrease the Beats Audio bass settings, press **fn+b**.



NOTE: You can also view and control the bass settings through the Windows® operating system. Select **Start > Control Panel > Hardware and Sound > Beats Audio Control Panel** to view and control the bass properties.

The following table shows and describes the Beats Audio icons.

Icon	Description
	Indicates that Beats Audio is enabled.
	Indicates that Beats Audio is disabled.

AMD Eyefinity Multi-Display technology

Your computer supports the new AMD™ Eyefinity Multi-Display technology that provides the following features:

- You can now have up to 3 external displays, as long as one of the displays is connected to the Mini DisplayPort on the computer.
- Provides a new display configuration by spanning the image across a group of external displays into a massive single large surface (SLS).

Example display configuration for single large surface (SLS)

When you use 3 external displays and span the image across them as an SLS, the computer display is turned off. The 3 external displays are connected to the computer using the external monitor port (VGA), the Mini DisplayPort, and the HDMI port.



NOTE: Identical resolution is required among all displays to form the SLS mode. Displays with different native resolutions can still form an SLS mode by using non-native resolutions.



NOTE: Windows 7 only supports 2 external displays. To configure 3 external displays in Windows 7, refer to [Using the AMD Catalyst Control Center on page 5](#).

Switching the screen image

Press the [switch screen image](#) action key to open a dialog box that shows the 4 configuration choices, independent of the number of connected display devices.

- Computer only mode—Turns off the external display and displays the image only on the computer display.
- Duplicate mode—Clones the computer display onto an external display that is connected to the external monitor port (VGA) on the computer.
- Extend mode—Extends the desktop to all connected external displays along with the computer display.
- Projector only mode—Turns off the computer display and sets all connected external displays to extended desktop.



NOTE: You can manage the video output and default output devices using the AMD Catalyst Control Center.

Using the AMD Catalyst Control Center

To configure desktops and displays and to manage AMD Eyefinity, you must use the AMD Catalyst™ Control Center.

To access the AMD Catalyst Control Center:

1. Select **Start > All Programs > Catalyst Control Center > CCC**.
2. Select **Desktops and Displays**.



NOTE: For additional information on using the AMD Catalyst Control Center, refer to the software Help.

Finding information

The computer comes with several resources to help you perform various tasks.

Resources	For information about
<i>Quick Setup</i> poster	<ul style="list-style-type: none">• How to set up the computer• Help to identify computer components
<i>Getting Started</i> To access this guide: Select Start > Help and Support > User Guides . – or – Select Start > All Programs > HP > HP Documentation .	<ul style="list-style-type: none">• Computer features• How to connect to a wireless network• How to use the keyboard and pointing devices• How to replace or upgrade the hard drive and memory modules• How to perform a backup and recovery• How to contact customer support• Computer specifications
<i>HP Notebook Reference Guide</i> To access this guide: Select Start > Help and Support > User Guides . – or – Select Start > All Programs > HP > HP Documentation .	<ul style="list-style-type: none">• Power management features• How to maximize battery life• How to use the multimedia features of the computer• How to protect the computer• How to care for the computer• How to update the software

Resources	For information about
<p>Help and Support</p> <p>To access Help and Support, select Start > Help and Support.</p> <p>NOTE: For country- or region-specific support, go to http://www.hp.com/support, select your country or region, and follow the on-screen instructions.</p>	<ul style="list-style-type: none"> • Operating system information • Software, driver, and BIOS updates • Troubleshooting tools • How to access technical support
<p><i>Regulatory, Safety and Environmental Notices</i></p> <p>To access this guide:</p> <p>Select Start > Help and Support > User Guides.</p> <p>– or –</p> <p>Select Start > All Programs > HP > HP Documentation.</p>	<ul style="list-style-type: none"> • Regulatory and safety information • Battery disposal information
<p><i>Safety & Comfort Guide</i></p> <p>To access this guide:</p> <p>Select Start > Help and Support > User Guides.</p> <p>– or –</p> <p>Select Start > All Programs > HP > HP Documentation.</p> <p>– or –</p> <p>Go to http://www.hp.com/ergo.</p>	<ul style="list-style-type: none"> • Proper workstation setup, posture, health, and work habits • Electrical and mechanical safety information
<p><i>Worldwide Telephone Numbers</i> booklet</p> <p>This booklet is provided with your computer.</p>	<p>HP support telephone numbers</p>
<p>HP Web site</p> <p>To access this Web site, go to http://www.hp.com/support.</p>	<ul style="list-style-type: none"> • Support information • Ordering parts and finding additional help • Software, driver, and BIOS updates • Accessories available for the device

Resources**For information about**

*Limited Warranty**

Warranty information

To access the warranty:

Select **Start > Help and Support > User Guides > View Warranty Information**.

– or –

Select **Start > All Programs > HP > HP Documentation > View Warranty Information**.

– or –

Go to <http://www.hp.com/go/orderdocuments>.

*You may find the expressly provided HP Limited Warranty applicable to your product located with the electronic guides on your computer and/or on the CD/DVD provided in the box. Some countries/regions may provide a printed HP Limited Warranty in the box. In countries/regions where the warranty is not provided in printed format, you may request a printed copy at <http://www.hp.com/go/orderdocuments> or write to:

- **North America:** Hewlett-Packard, MS POD, 11311 Chinden Blvd, Boise, ID 83714, USA
- **Europe, Middle East, Africa:** Hewlett-Packard, POD, Via G. Di Vittorio, 9, 20063, Cernusco s/ Naviglio (MI), Italy
- **Asia Pacific:** Hewlett-Packard, POD, P.O. Box 200, Alexandra Post Office, Singapore 911507

Please include your product number, warranty period (found on your serial number label), name, and postal address.

2 Getting to know your computer

Top



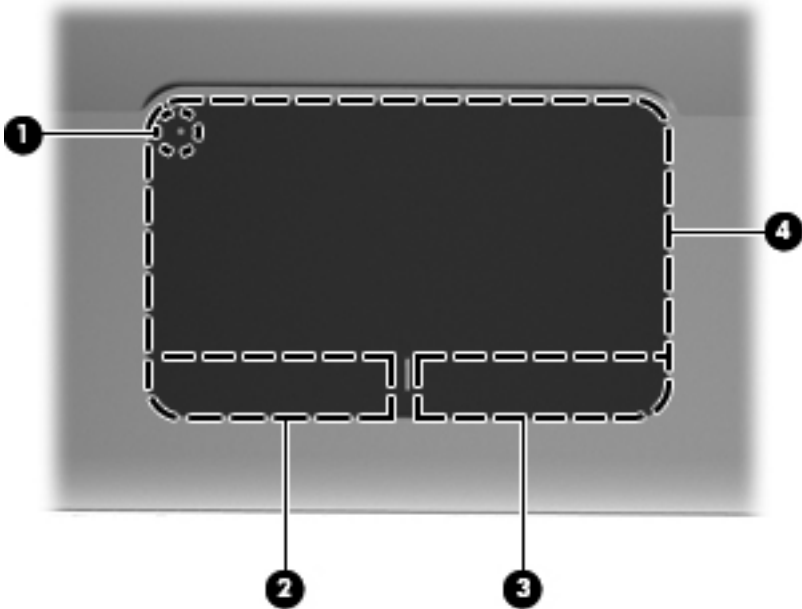

TouchPad

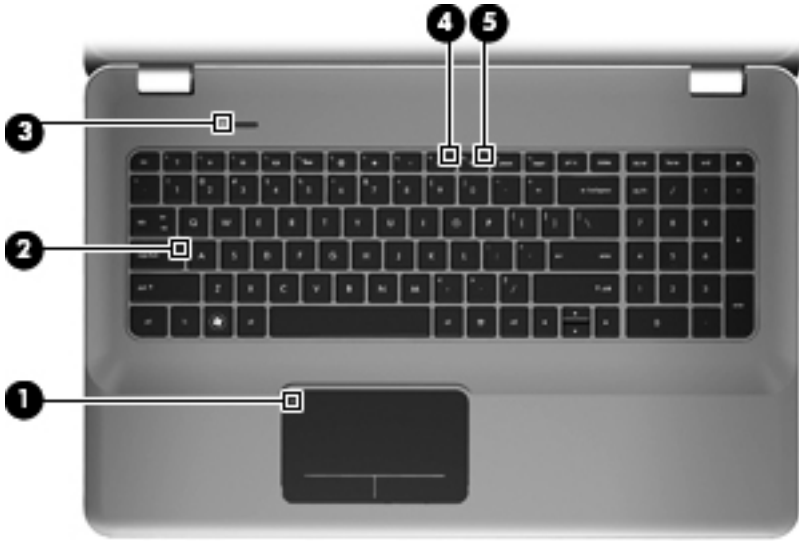

Component	Description
(1)  TouchPad light	Turns the TouchPad on and off. Quickly double-tap the TouchPad light to turn the TouchPad on and off.
(2) Left TouchPad button	Functions like the left button on an external mouse.
(3) Right TouchPad button	Functions like the right button on an external mouse.
(4) TouchPad zone	Moves the pointer and selects or activates items on the screen.

Lights



Component	Description
(1)  TouchPad light	<ul style="list-style-type: none">• Amber: The TouchPad is off.• Off: The TouchPad is on.
(2) Caps lock light	<ul style="list-style-type: none">• White: Caps lock is on.• Off: Caps lock is off.
(3)  Power light	<ul style="list-style-type: none">• White: The computer is on.• Blinking white: The computer is in the Sleep state.• Off: The computer is off or in Hibernation.
(4)  Mute light	<ul style="list-style-type: none">• Amber: Computer sound is off.• Off: Computer sound is on.
(5)  Wireless light	<ul style="list-style-type: none">• White: An integrated wireless device, such as a wireless local area network (WLAN) device, is on. NOTE: Wireless devices are enabled at the factory.• Amber: All wireless devices are off.







Button

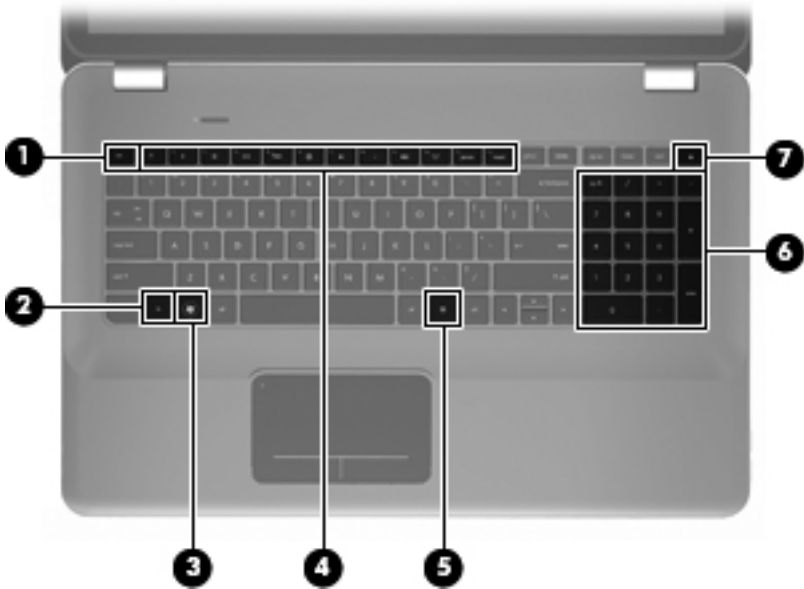

Component	Description
 Power button	<ul style="list-style-type: none">• When the computer is off, press the button to turn on the computer.• When the computer is on, press the button briefly to initiate Sleep.• When the computer is in the Sleep state, press the button briefly to exit Sleep.• When the computer is in Hibernation, press the button briefly to exit Hibernation. <p>If the computer has stopped responding and Windows shutdown procedures are ineffective, press and hold the power button for at least 5 seconds to turn off the computer.</p> <p>To learn more about your power settings, select Start > Control Panel > System and Security > Power Options, or refer to the <i>HP Notebook Reference Guide</i>.</p>

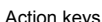

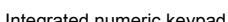
Keys



Component	Description
(1)  esc key	Displays system information when pressed in combination with the fn key.
(2)  fn key	Executes frequently used system functions when pressed in combination with the b key or the esc key.
(3)  Windows logo key	Displays the Windows Start menu.
(4)  Action keys	Execute frequently used system functions.
(5)  Windows applications key	Displays a shortcut menu for items beneath the pointer.
(6)  Integrated numeric keypad	Can be used like an external numeric keypad.
(7)  Optical drive eject key	Ejects the optical disc from the optical drive.

Front





Component	Description
(1)  Power light	<ul style="list-style-type: none">• White: The computer is on.• Blinking white: The computer is in the Sleep state.• Off: The computer is off or in Hibernation.
(2)  Hard drive light	<ul style="list-style-type: none">• Blinking white: The hard drive is being accessed.• Amber: HP ProtectSmart Hard Drive Protection has temporarily parked the hard drive. <p>NOTE: For information on HP ProtectSmart Hard Drive Protection, refer to the <i>HP Notebook Reference Guide</i>.</p>
(3) Speakers (2)	Produce sound.

Right-side









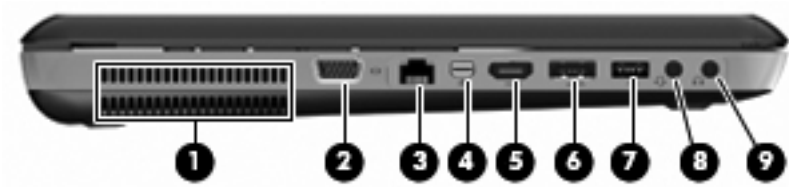

Component	Description
(1)  USB ports (2)	Connect optional USB devices.
(2) Digital Media Slot	Supports the following digital card formats: <ul style="list-style-type: none">• Memory Stick• Memory Stick Pro• MultiMediaCard• Secure Digital (SD) Memory Card• Secure Digital High Capacity Memory Card• xD-Picture Card
(3) Optical drive	Reads and writes to an optical disc. CAUTION: Do not insert 8-cm optical discs into the optical drive. This can cause damage to the computer.
(4) Battery light	<ul style="list-style-type: none">• White: The computer is connected to external power and the battery is fully charged.• Amber: A battery is charging.• Blinking amber: The battery has reached a low battery level, a critical battery level, or there is a battery error.• Off: The computer is running on battery power.

Component	Description
(5)  Power connector	Connects an AC adapter.
(6)  Security cable slot	Attaches an optional security cable to the computer. NOTE: The security cable is designed to act as a deterrent, but it may not prevent the computer from being mishandled or stolen.

Left-side



Component	Description
(1) Vent	Enables airflow to cool internal components. NOTE: The computer fan starts up automatically to cool internal components and prevent overheating. It is normal for the internal fan to cycle on and off during routine operation.
(2)  External monitor port	Connects an external VGA monitor or projector.
(3)  RJ-45 (network) jack	Connects a network cable.
(4)  Mini DisplayPort	Connects an optional digital display device, such as a high-performance monitor or projector.
(5)  HDMI port	Connects an optional video or audio device, such as a high-definition television, or any compatible digital or audio component.
(6)  eSATA/USB port	Connects a high-performance eSATA component, such as an eSATA external hard drive, or connects an optional USB 2.0 device.
(7)  SuperSpeed USB port	Connects an optional USB 3.0 device and provides enhanced USB power performance. NOTE: The SuperSpeed USB port is also compatible with USB 1.0 and 2.0 devices.

Component	Description
<p>(8)  Audio-out (headphone) jack/Audio-in (microphone) jack</p>	<p>Produces sound when connected to optional powered stereo speakers, headphones, earbuds, a headset, or television audio. Also connects an optional headset microphone.</p> <p>WARNING! To reduce the risk of personal injury, adjust the volume before putting on headphones, earbuds, or a headset. For additional safety information, refer to the <i>Regulatory, Safety, and Environmental Notices</i>.</p> <p>NOTE: When a device is connected to the jack, the computer speakers are disabled.</p>
<p>(9)  Audio-out (headphone) jack</p>	<p>Produces sound when connected to optional powered stereo speakers, headphones, earbuds, a headset, or television audio.</p> <p>WARNING! To reduce the risk of personal injury, adjust the volume before putting on headphones, earbuds, or a headset. For additional safety information, refer to the <i>Regulatory, Safety, and Environmental Notices</i>.</p> <p>NOTE: When a device is connected to the jack, the computer speakers are disabled.</p>

Display

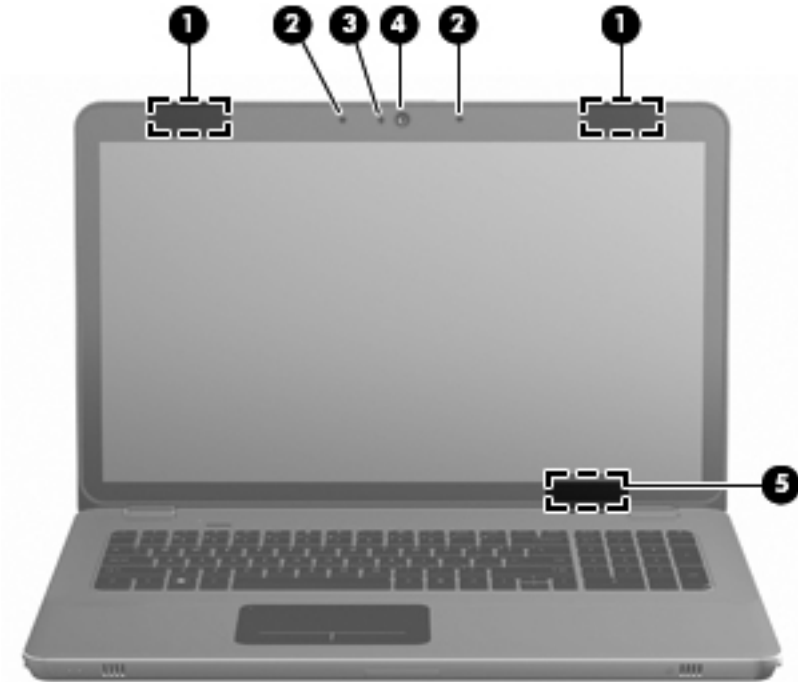



Component	Description
(1) WLAN antennas (2)*	Send and receive wireless signals to communicate with wireless local area networks (WLAN).
(2) Internal microphones (2)	Record sound.
(3) Webcam light	On: The webcam is in use.
(4) Webcam	Records video and captures still photographs. To access the webcam, select Start > All Programs > CyberLink YouCam .

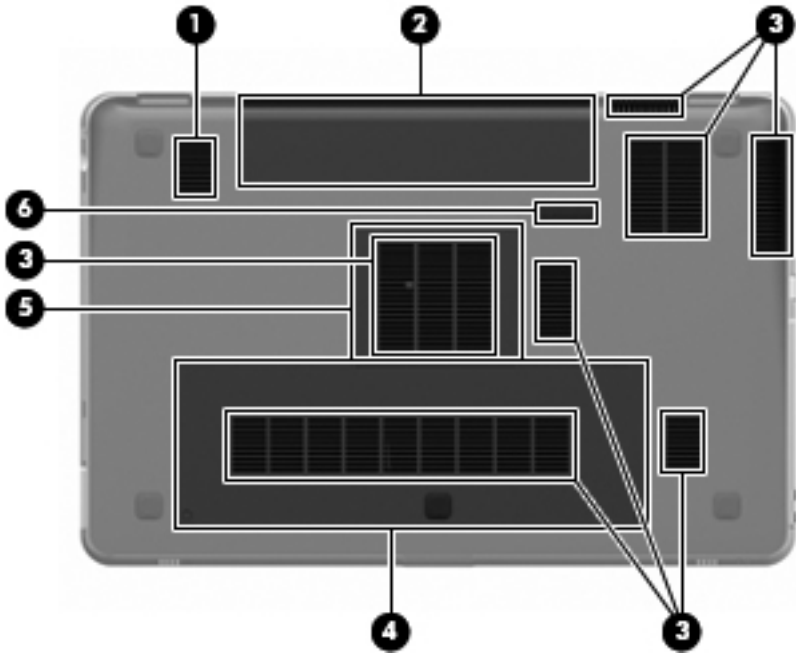

Component	Description
(5) Internal display switch	Turns off the display and initiates Sleep if the display is closed while the power is on. NOTE: The internal display switch is not visible from the outside of the computer.

*The antennas are not visible from the outside of the computer. For optimal transmission, keep the areas immediately around the antennas free from obstructions. To see wireless regulatory notices, refer to the section of the *Regulatory, Safety, and Environmental Notices* that applies to your country or region. These notices are located in Help and Support.

Bottom



Component	Description
(1) Subwoofer	Provides superior bass sound.
(2) Battery bay	Holds the battery. NOTE: The battery is preinstalled in the battery bay at the factory.
(3) Vents (7)	Enable airflow to cool internal components. NOTE: The computer fan starts up automatically to cool internal components and prevent overheating. It is normal for the internal fan to cycle on and off during routine operation.
(4)  Hard drive bay	Holds the hard drive.

Component	Description
(5)  Memory module compartment	Holds the memory modules.
(6)  Battery release latch	Releases the battery from the battery bay.

3 Networking

- [Using an Internet service provider \(ISP\)](#)
- [Connecting to a wireless network](#)



NOTE: Internet hardware and software features vary depending on computer model and your location.

Your computer may support one or both of the following types of Internet access:

- **Wireless**—For mobile Internet access, you can use a wireless connection. Refer to [Connecting to an existing WLAN on page 22](#) or [Setting up a new WLAN network on page 22](#).
- **Wired**—You can access the Internet by connecting to a wired network. For information on connecting to a wired network, refer to the *HP Notebook Reference Guide*.

Using an Internet service provider (ISP)

Before you can connect to the Internet, you must establish an ISP account. Contact a local ISP to purchase Internet service and a modem. The ISP will help set up the modem, install a network cable to connect your wireless computer to the modem, and test the Internet service.



NOTE: Your ISP will give you a user ID and password to access the Internet. Record this information and store it in a safe place.

The following features will help you set up a new Internet account or configure the computer to use an existing account:

- **Internet Services & Offers (available in some locations)**—This utility assists with signing up for a new Internet account and configuring the computer to use an existing account. To access this utility, select **Start > All Programs > Online Services > Get Online**.
- **ISP-provided icons (available in some locations)**—These icons may be displayed either individually on the Windows desktop or grouped in a desktop folder named Online Services. To set up a new Internet account or configure the computer to use an existing account, double-click an icon, and then follow the on-screen instructions.
- **Windows Connect to the Internet Wizard**—You can use the Windows Connect to the Internet Wizard to connect to the Internet in any of these situations:

- You already have an account with an ISP.
- You do not have an Internet account and want to select an ISP from the list provided within the wizard. (The list of ISP providers is not available in all regions.)
- You have selected an unlisted ISP, and the ISP has provided you with information such as a specific IP address and POP3 and SMTP settings.

To access the Windows Connect to the Internet Wizard and instructions for using it, select **Start > Control Panel > Network and Internet > Network and Sharing Center**.



NOTE: If you are prompted within the wizard to choose between enabling or disabling Windows Firewall, choose to enable the firewall.

Connecting to a wireless network

Wireless technology transfers data across radio waves instead of wires. Your computer may be equipped with one or more of the following wireless devices:

- Wireless local area network (WLAN) device
- HP Mobile Broadband Module, a wireless wide area network (WWAN) device
- Bluetooth® device

For more information on wireless technology and connecting to a wireless network, refer to the *HP Notebook Reference Guide* and information and Web site links provided in Help and Support.

Connecting to an existing WLAN

1. Turn on the computer.
2. Be sure that the WLAN device is on.
3. Click the network icon in the notification area, at the far right of the taskbar.
4. Select a network to connect to.
5. Click **Connect**.
6. If required, enter the security key.

Setting up a new WLAN network

Required equipment:

- A broadband modem (either DSL or cable) **(1)** and high-speed Internet service purchased from an Internet service provider (ISP)
- A wireless router (purchased separately) **(2)**
- Your new wireless computer **(3)**



NOTE: Some modems have a built-in wireless router. Check with your ISP to determine what type of modem you have.

The illustration shows an example of a completed WLAN network installation that is connected to the Internet. As your network grows, additional wireless and wired computers can be connected to the network to access the Internet.

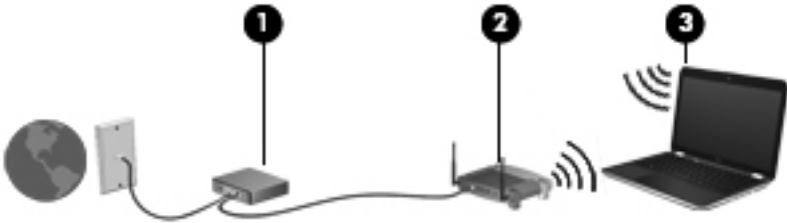

Configuring a wireless router

For help in setting up a WLAN, refer to the information provided by your router manufacturer or your ISP.

The Windows operating system also provides tools to help you set up a new wireless network. To use the Windows tools to set up your network, select **Start > Control Panel > Network and Internet > Network and Sharing Center > Set up a new connection or network > Set up a new network**. Then follow the on-screen instructions.



NOTE: It is recommended that you initially connect your new wireless computer to the router by using the network cable provided with the router. When the computer successfully connects to the Internet, you can disconnect the cable, and then access the Internet through your wireless network.

Protecting your WLAN

When you set up a WLAN or access an existing WLAN, always turn on security features to protect your network from unauthorized access.

For information on protecting your WLAN, refer to the *HP Notebook Reference Guide*.

4 Keyboard and pointing devices

Using the keyboard

Using the action keys

Action keys are used for performing customized actions that are assigned to specific keys at the top of the keyboard.

The icons on the **f1** through **f10** keys represent the action key functions. To use an action key, press and hold this key to activate the assigned function.



NOTE: The action key feature is enabled at the factory. You can disable this feature in Setup Utility (BIOS) and revert back to standard settings by pressing the **fn** key and one of the function keys to activate the assigned function. Refer to the “Setup Utility (BIOS) and System Diagnostics” chapter in the HP Notebook Reference Guide for instructions.



CAUTION: Use extreme care when making changes in Setup Utility. Errors can prevent the computer from operating properly.



Icon	Key	Description
------	-----	-------------



f1

Opens Help and Support, which provides information about your Windows operating system and computer, answers to questions and tutorials, and updates to your computer.

Help and Support also provides automated troubleshooting and links to support specialists.









f2

Decreases the screen brightness level when you hold down this key.



f3

Increases the screen brightness level when you hold down this key.

Icon	Key	Description
	f4	<p>Switches the screen image among display devices connected to the system. For example, if a monitor is connected to the computer, pressing this key alternates the screen image from computer display to monitor display to simultaneous display on both the computer and the monitor.</p> <p>Most external monitors receive video information from the computer using the external VGA video standard. The switch screen image key can also alternate images among other devices that are receiving video information from the computer.</p> <p>The computer also supports multiple display outputs. When you press the switch screen image key, you can select from four different video outputs:</p> <ul style="list-style-type: none"> • Computer only mode • Duplicate mode • Extend mode • Projector only mode
	f5	<p>Turns the keyboard backlight on and off.</p> <p>NOTE: The keyboard backlight is turned on at the factory. To extend battery power, turn off the keyboard backlight.</p>
	f6	<p>Opens a Web browser.</p> <p>NOTE: Until you set up your Internet or network services, this key opens the Internet Connection Wizard.</p>
	f7	Decreases speaker volume incrementally when you hold down this key.
	f8	Increases speaker volume incrementally when you hold down this key.
	f9	Mutes or restores speaker sound.
	f10	<p>Turns the wireless feature on or off.</p> <p>NOTE: This key does not establish a wireless connection. To establish a wireless connection, a wireless network must be set up.</p>

Using the hotkeys

A hotkey is a combination of the **fn** key (1) and either the **esc** key (2) or the **b** key (3).

To use a hotkey:

- ▲ Briefly press the **fn** key, and then briefly press the second key of the hotkey combination.

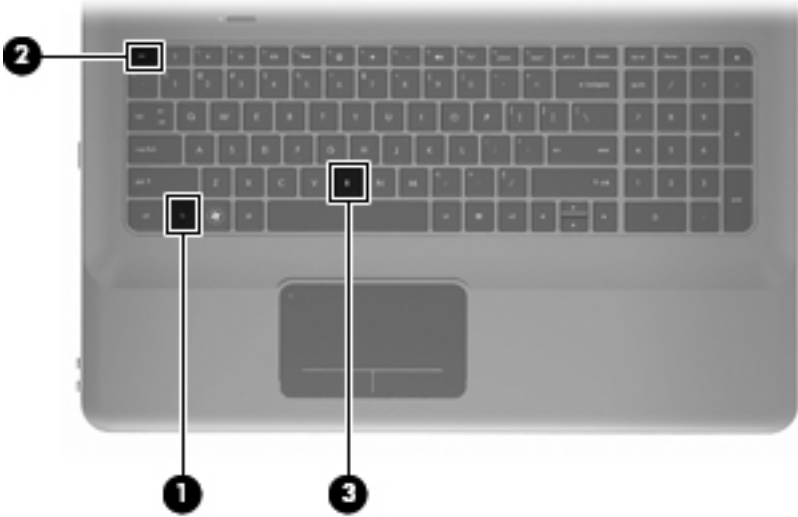

Function	Hotkey	Description
Display system information.	fn+esc	Displays information about system hardware components and the system BIOS version number.
Control the bass settings.	fn+b	<p>Increases or decreases the Beats Audio bass settings.</p> <p>Beats Audio is an enhanced audio profile that provides a deep, controlled bass while maintaining a clear sound. Beats Audio is enabled by default.</p> <p>You can also view and control the bass settings through the Windows operating system. Select Start > Control Panel > Hardware and Sound > Beats Audio Control Panel to view and control the bass properties.</p>

Using the keypad

Using the integrated numeric keypad



Component	Description
Integrated numeric keypad	Can be used like an external numeric keypad. NOTE: The computer does not have a num lock key.

Using pointing devices

 **NOTE:** In addition to the pointing devices included with your computer, you can use an external USB mouse (purchased separately) by connecting it to one of the USB ports on the computer.

Setting pointing device preferences

Use Mouse Properties in Windows to customize settings for pointing devices, such as button configuration, click speed, and pointer options.

To access Mouse Properties, select **Start > Devices and Printers**. Then right-click the device representing your computer, and select **Mouse settings**.

Using the TouchPad

To move the pointer, slide one finger across the TouchPad in the direction you want the pointer to go. Use the left and right TouchPad buttons like the corresponding buttons on an external mouse.

Turning the TouchPad off and on

To turn the TouchPad off and on, quickly double-tap the TouchPad light.



NOTE: The TouchPad light is off when the TouchPad is on.

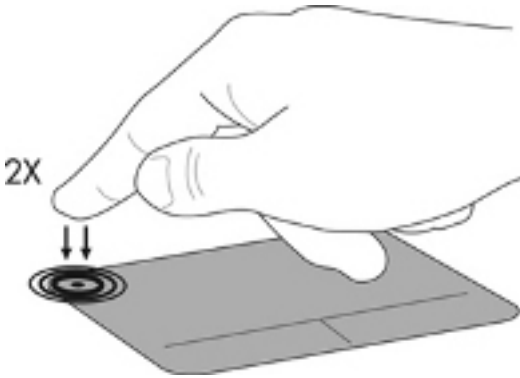

Navigating

To move the pointer, slide one finger across the TouchPad in the direction you want the pointer to go.

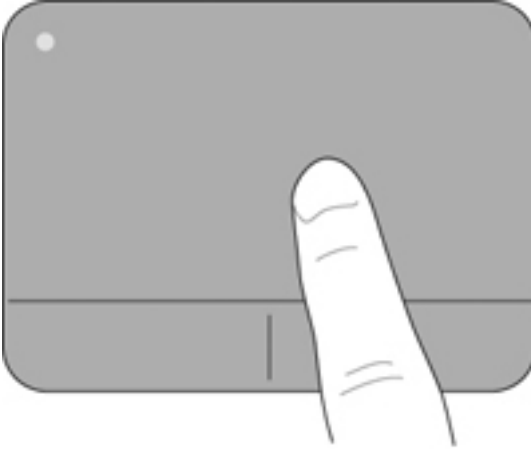

Selecting

Use the left and right TouchPad buttons like the corresponding buttons on an external mouse.

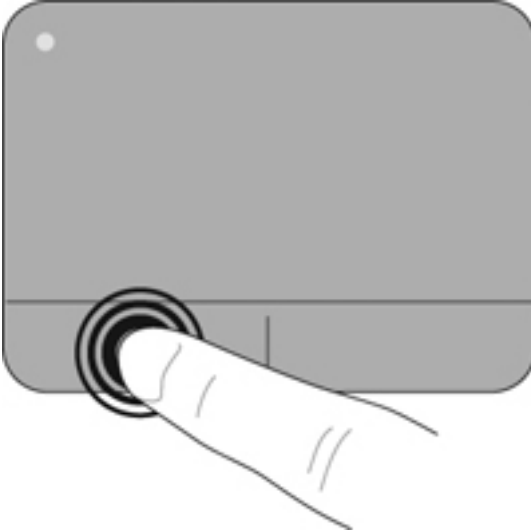

Using TouchPad gestures

The TouchPad supports a variety of gestures. To use TouchPad gestures, place two fingers on the TouchPad at the same time.



NOTE: TouchPad gestures are not supported in all computer programs.

To view the demonstration of a gesture:

1. Click the **Show hidden icons** icon in the notification area, at the far right of the taskbar.
2. Right-click the **Synaptics Pointing Device** icon , and then click **TouchPad Properties**.
3. Click a gesture to activate the demonstration.

To turn the gestures on and off:

1. Click the **Show hidden icons** icon in the notification area, at the far right of the taskbar.
2. Right-click the **Synaptics Pointing Device** icon , and then click **TouchPad Properties**.
3. Select the check box next to the gesture that you want to turn on or off.
4. Click **Apply**, and then click **OK**.

Scrolling

Scrolling is useful for moving up, down, or sideways on a page or image. To scroll, place two fingers slightly apart on the TouchPad, and then drag them across the TouchPad in an up, down, left, or right motion.

 **NOTE:** Scrolling speed is controlled by finger speed.

 **NOTE:** Two-finger scrolling is enabled at the factory.

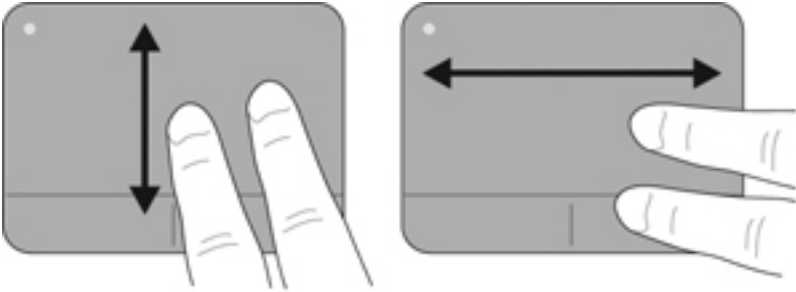

Pinching/Zooming

Pinching allows you to zoom in or out on images or text.

- Zoom in by placing two fingers together on the TouchPad, and then moving them apart.
- Zoom out by placing two fingers apart on the TouchPad, and then moving them together.

 **NOTE:** Pinching/zooming is enabled at the factory.

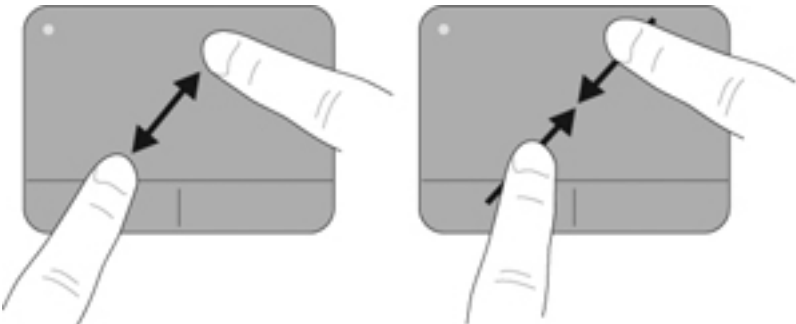

Rotating

Rotating allows you to rotate items such as photos. To rotate, anchor your left forefinger in the TouchPad zone. Move the right forefinger around the anchored finger in a sweeping motion, moving from 12 o'clock to 3 o'clock. To reverse the rotation, move your right forefinger from 3 o'clock to 12 o'clock.



NOTE: Rotating is disabled at the factory.

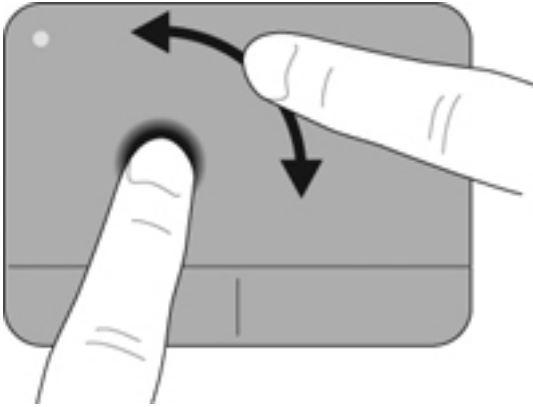

Flicking

Flicking allows you to navigate through screens or quickly scroll through documents. To flick, use three fingers to touch the TouchPad zone in a light, quick flicking motion up, down, left, or right.



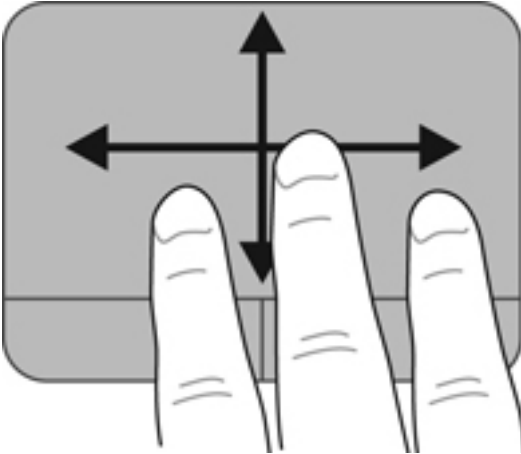

NOTE: Three-finger flicking is disabled at the factory.



5 Maintenance

Removing or inserting the battery

 **NOTE:** The battery is preinstalled in the battery bay at the factory.

 **NOTE:** For additional information on using the battery, refer to the *HP Notebook Reference Guide*.

Removing the battery

 **CAUTION:** Removing a battery that is the sole power source for the computer can cause loss of information. To prevent loss of information, save your work and initiate Hibernation or shut down the computer through Windows before removing the battery.

1. Slide the battery release latch (1) to release the battery.
2. Pivot the battery (2) upward and remove it from the computer (3).

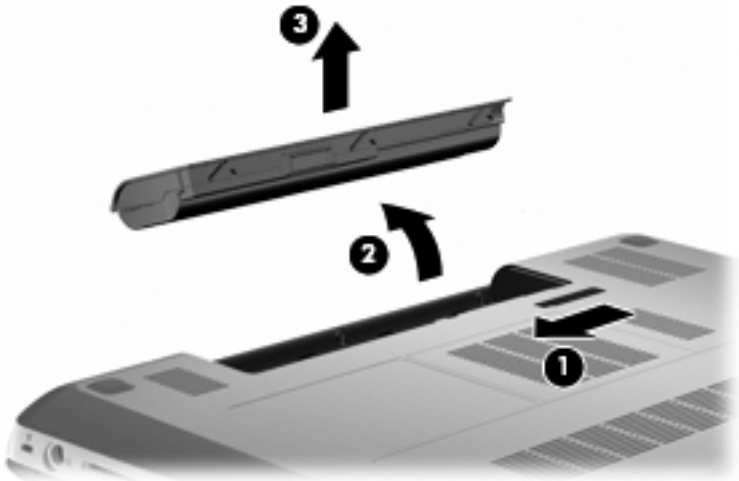

Inserting the battery

- ▲ Align the tabs on the battery (1) with the notches on the outer edge of the battery bay, and rotate the battery (2) into the battery bay until it is seated. The battery release latch (3) automatically locks the battery into place.

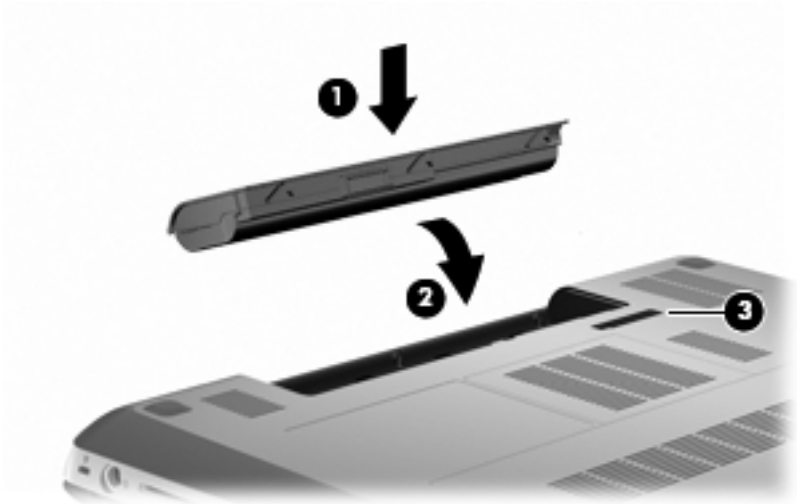

Replacing or upgrading the hard drive

CAUTION: To prevent information loss or an unresponsive system:
Shut down the computer before removing the hard drive from the hard drive bay. Do not remove the hard drive while the computer is on, in the Sleep state, or in Hibernation.

If you are not sure whether the computer is off or in Hibernation, turn the computer on by pressing the power button. Then shut down the computer through the operating system.

NOTE: Select computer models can support up to two drives. To view the drives installed on the computer, select **Start > Computer**.

Removing the hard drive

1. Save your work and shut down the computer.
2. Disconnect all external devices connected to the computer.
3. Remove external power from the AC outlet and remove the battery.
4. Loosen the 2 hard drive cover screws (1).
5. Remove the hard drive cover (2).

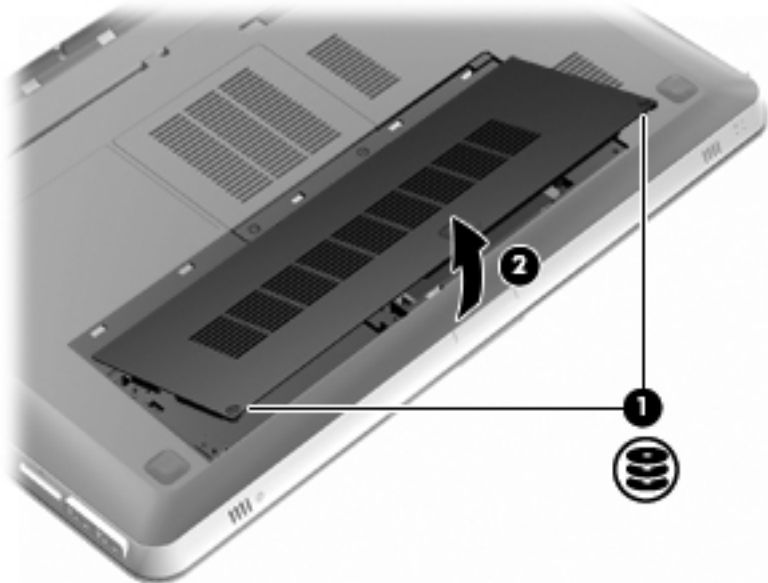

6. Disconnect the hard drive cable (1) from the computer, and then lift the hard drive (2) out of the hard drive bay.

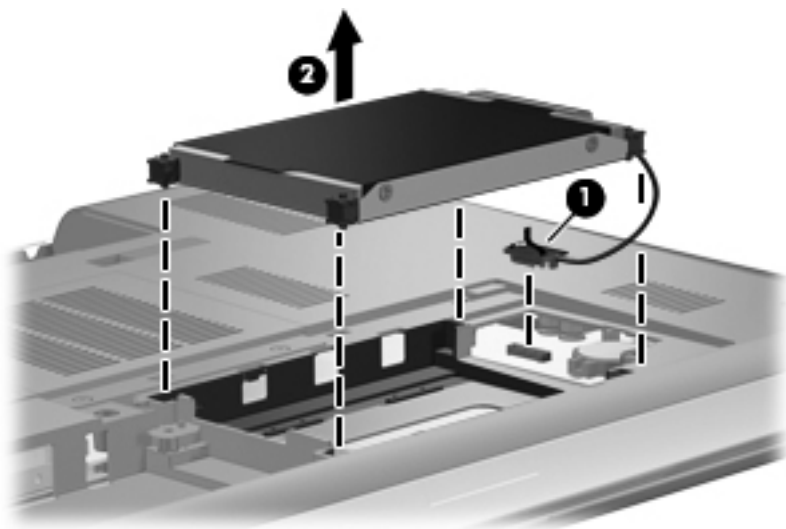

7. Disconnect the hard drive cable from the hard drive.

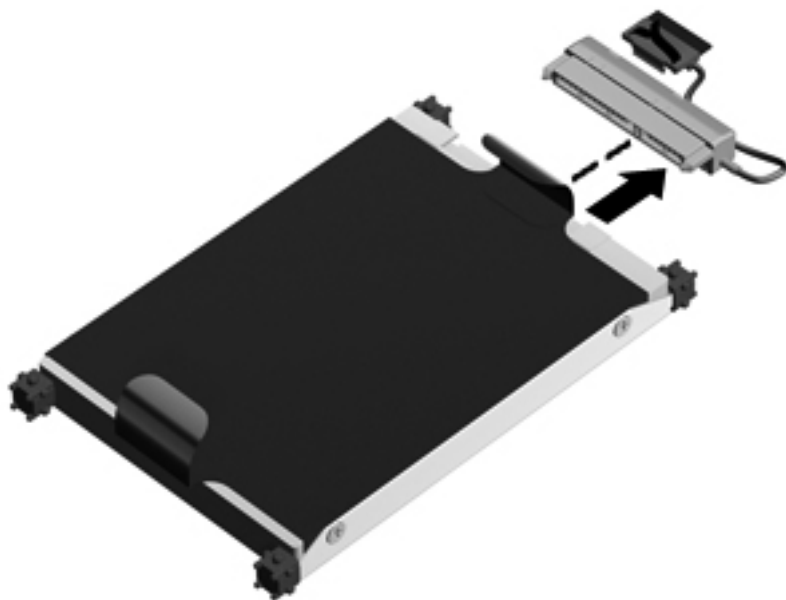

Installing a hard drive

1. Connect the hard drive cable to the hard drive.

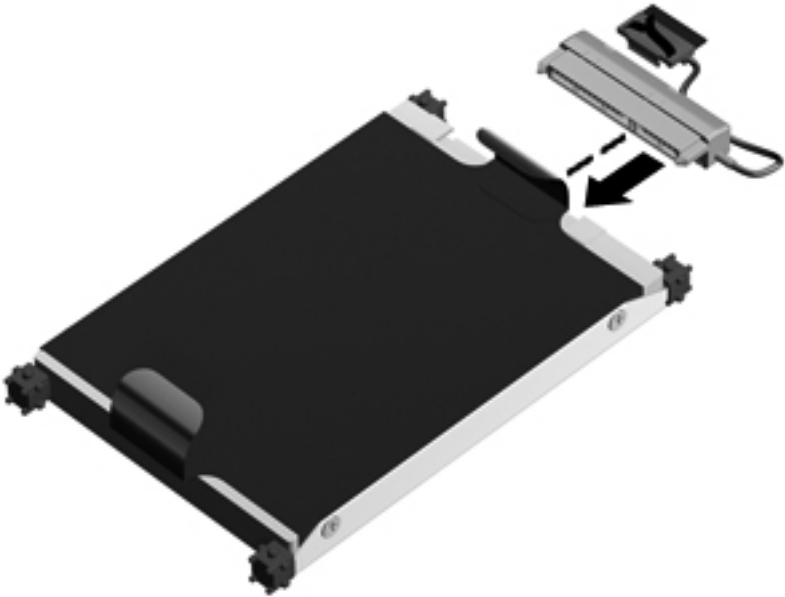

2. Insert the hard drive (1) into the hard drive bay, and then connect the hard drive cable (2) to the computer.

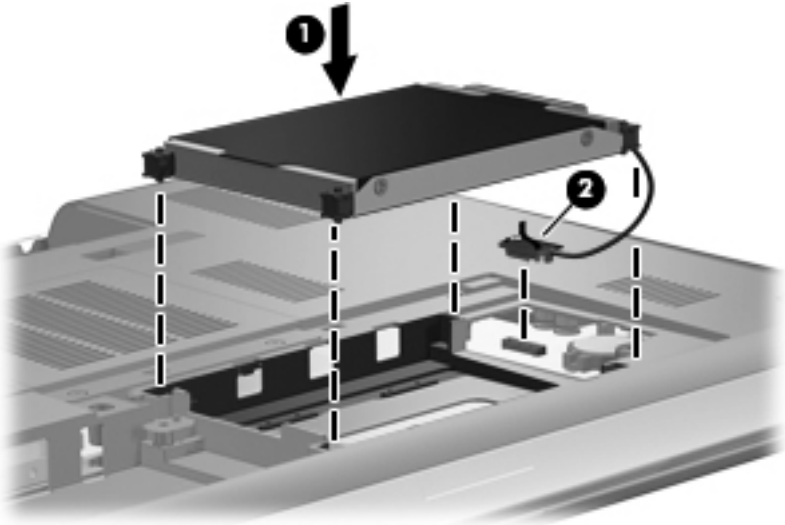

3. Align the tabs **(1)** on the hard drive cover with the notches on the computer.
4. Close the cover **(2)**.
5. Tighten the hard drive cover screws **(3)**.

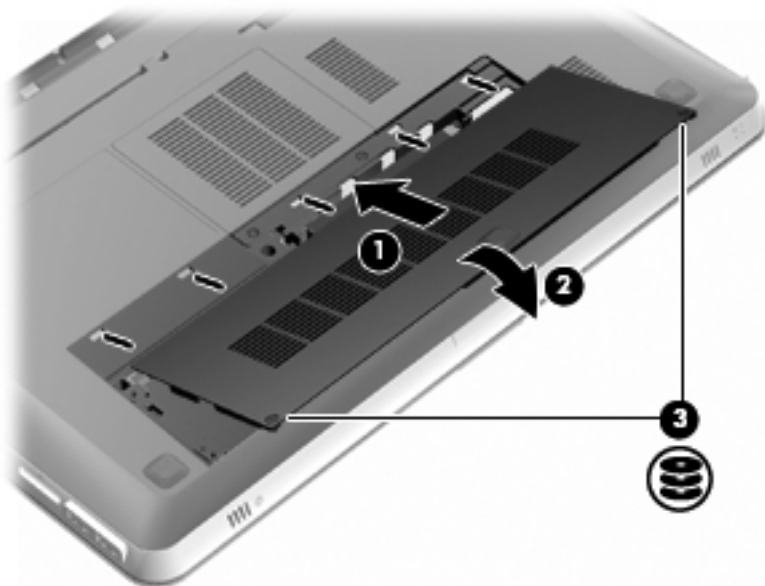



6. Replace the battery.
7. Reconnect external power and external devices.
8. Turn on the computer.

Adding or replacing memory modules

The computer has two memory module slots. The memory module slots are located on the bottom of the computer under the hard drive cover. The memory capacity of the computer can be upgraded by adding a memory module or replacing the existing memory module in one of the memory module slots.

 **WARNING!** To reduce the risk of electric shock and damage to the equipment, unplug the power cord and remove all batteries before installing a memory module.

 **CAUTION:** Electrostatic discharge (ESD) can damage electronic components. Before beginning any procedure, ensure that you are discharged of static electricity by touching a grounded metal object.

 **NOTE:** To use a dual-channel configuration when adding a second memory module, be sure that both memory modules are the same capacity.

To add or replace a memory module:

 **CAUTION:** To prevent information loss or an unresponsive system: Shut down the computer before removing a memory module from the computer. Do not remove a memory module while the computer is on, in the Sleep state, or in Hibernation.

If you are not sure whether the computer is off or in Hibernation, turn the computer on by pressing the power button. Then shut down the computer through the operating system.

1. Save your work and shut down the computer.
2. Disconnect all external devices connected to the computer.
3. Remove external power from the AC outlet and remove the battery.
4. Remove the hard drive cover.
 - a. Loosen the 2 hard drive cover screws **(1)**.

- - b.** Remove the hard drive cover (**2**).

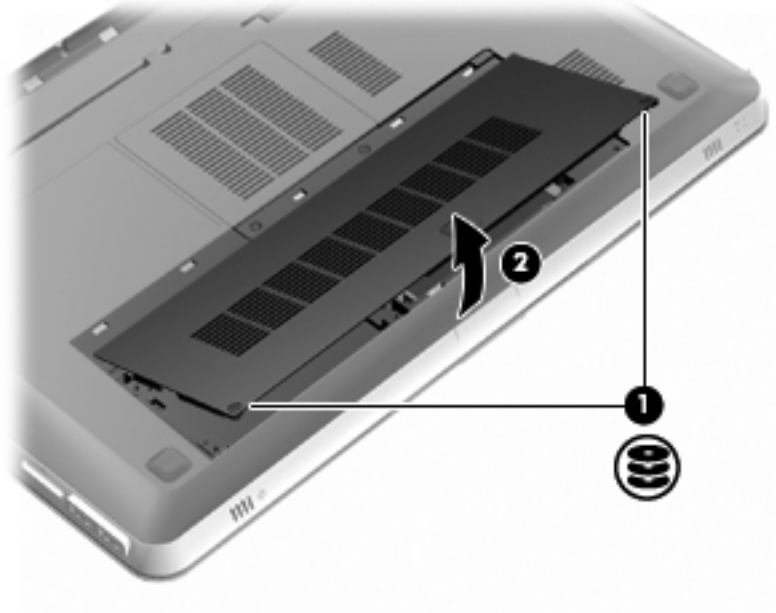

- 5.** Remove the memory module compartment cover.
 - a.** Loosen the 2 memory module compartment cover screws (**1**).

- b. Remove the memory module compartment cover (2).

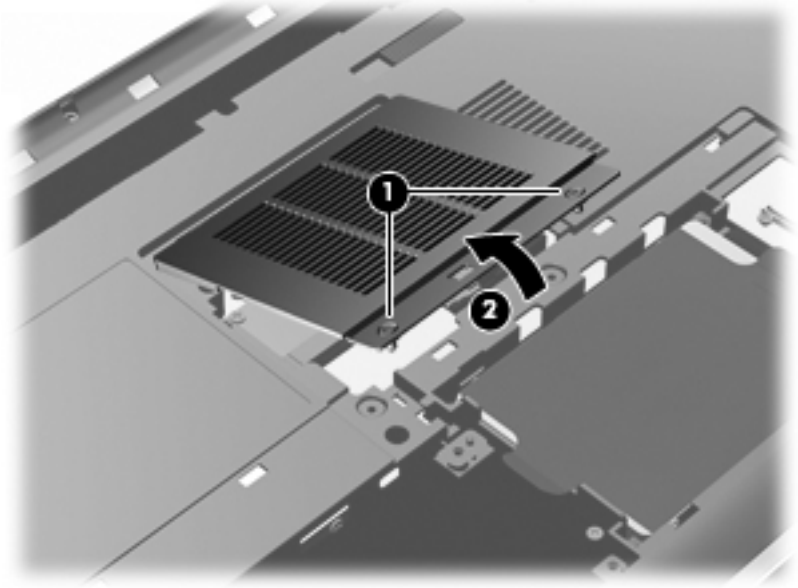

6. If you are replacing a memory module, remove the existing memory module:
 - a. Pull away the retention clips (1) on each side of the memory module. The memory module tilts up.

- b. Grasp the edge of the memory module (2), and then gently pull the module out of the memory module slot.

CAUTION: To prevent damage to the memory module, hold the memory module by the edges only. Do not touch the components on the memory module. To protect a memory module after removal, place it in an electrostatic-safe container.

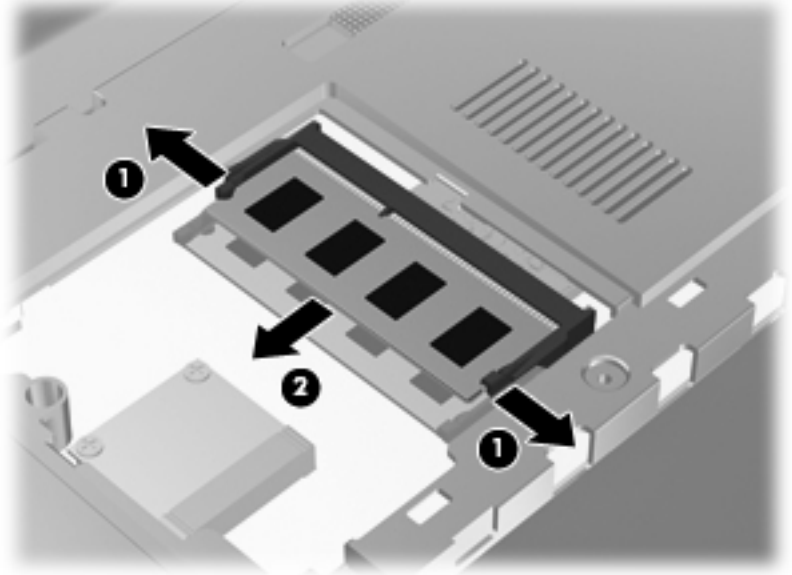

7. Insert a new memory module:

CAUTION: To prevent damage to the memory module, hold the memory module by the edges only. Do not touch the components on the memory module, and do not bend the memory module.

- a. Align the notched edge (1) of the memory module with the tab in the memory module slot.
- b. With the memory module at a 45-degree angle from the surface of the memory module compartment, press the module (2) into the memory module slot until it is seated.

- c. Gently press the memory module **(3)** down, applying pressure to both the left and right edges of the memory module, until the retention clips snap into place.

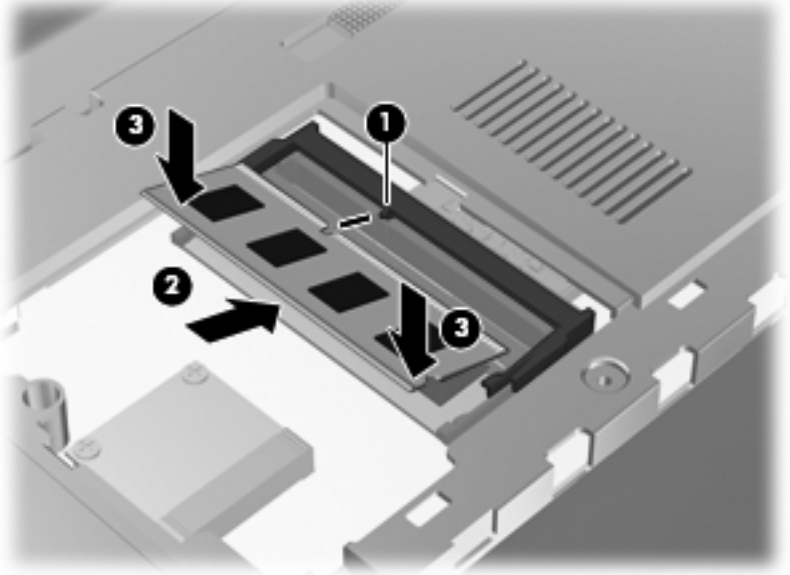

8. Replace the memory module compartment cover.
 - a. Align the tabs **(1)** on the memory module compartment cover with the notches on the computer.
 - b. Close the cover **(2)**.

- c. Tighten the 2 memory module compartment cover screws (3).

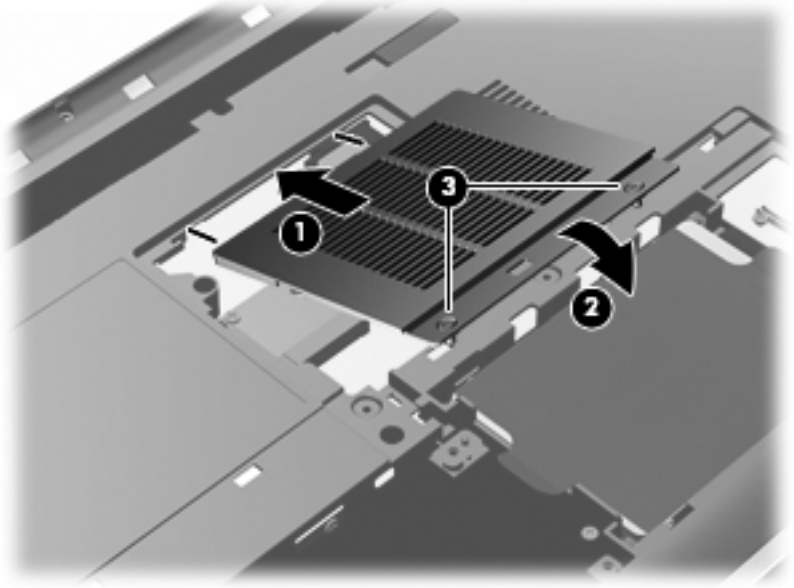

9. Replace the hard drive cover.
 - a. Align the tabs (1) on the hard drive cover with the notches on the computer.
 - b. Close the cover (2).

- c. Tighten the 2 hard drive cover screws (3).

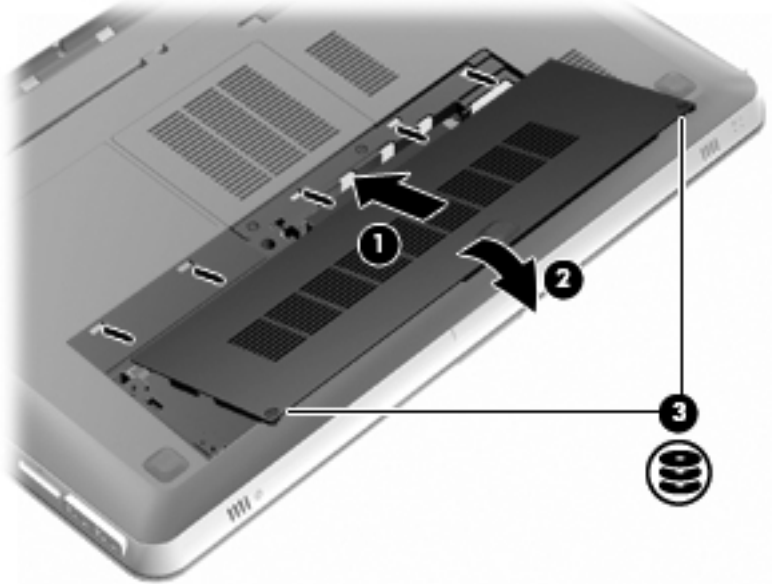

10. Replace the battery.
11. Reconnect external power and external devices.
12. Turn on the computer.

Cleaning your computer

Cleaning the display

 **CAUTION:** To prevent permanent damage to the computer, never spray water, cleaning fluids, or chemicals on the display.

To remove smudges and lint, frequently clean the display with a soft damp, lint-free cloth. If the screen requires additional cleaning, use premoistened antistatic wipes or an antistatic screen cleaner.

Cleaning the TouchPad and keyboard

Dirt and grease on the TouchPad can cause the pointer to jump around on the screen. To avoid this, clean the TouchPad with a damp cloth, and wash your hands frequently when using the computer.

 **WARNING!** To reduce the risk of electric shock or damage to internal components, do not use a vacuum cleaner attachment to clean the keyboard. A vacuum cleaner can deposit household debris on the keyboard surface.

Clean the keyboard regularly to prevent keys from sticking, and to remove dust, lint, and particles that can become trapped beneath the keys. A can of compressed air with a straw extension can be used to blow air around and under the keys to loosen and remove debris.

Updating programs and drivers

HP recommends that you update your programs and drivers on a regular basis with the latest versions. Go to <http://www.hp.com/support> to download the latest versions. You can also register to receive automatic update notifications when they become available.

6 Backup and recovery

- [Restore](#)
- [Creating restore media](#)
- [Performing a system restore](#)
- [Backing up and recovering your information](#)

Your computer includes tools provided by the operating system and HP to help you safeguard your information and restore it if ever needed.

This chapter provides information on the following topics:

- Creating a set of recovery discs or a recovery flash drive (HP Recovery Manager software feature)
- Performing a system restore (from the partition, recovery discs, or a recovery flash drive)
- Backing up your information
- Recovering a program or driver

Restore

In the event of hard drive failure, to restore your system to its factory image you will need a set of recovery discs or a recovery flash drive that you can create using HP Recovery Manager. HP recommends that you use this software to create either a set of recovery discs or a recovery flash drive immediately after software setup.

If for some other reason you need to restore your system, this can be achieved using the HP Recovery partition (select models only), without the need for recovery discs or a recovery flash drive. To check for the presence of a recovery partition, click **Start**, right-click **Computer**, click **Manage**, and then click **Disk Management**. If the recovery partition is present, a Recovery drive is listed in the window.



CAUTION: HP Recovery Manager (partition or discs/flash drive) restores only software that was preinstalled at the factory. Software not provided with this computer must be reinstalled manually.



NOTE: Recovery discs have been included if your computer does not have a recovery partition.

Creating restore media

HP recommends that you create either a set of recovery discs or a recovery flash drive to be sure that you can restore your computer to its original factory state if the hard drive fails, or if for any reason you cannot restore using the recovery partition tools. Create these discs or the flash drive after setting up the computer for the first time.

 **NOTE:** HP Recovery Manager allows the creation of only one set of recovery discs or one recovery flash drive. Handle these discs or the flash drive carefully and keep them in a safe place.

 **NOTE:** If your computer does not include an integrated optical drive, you can use an optional external optical drive (purchased separately) to create recovery discs, or you can purchase recovery discs for your computer from the HP Web site. If you use an external optical drive, it must be connected directly to a USB port on the computer, not to a USB port on an external device, such as a USB hub.

Guidelines:

- Purchase high-quality DVD-R, DVD+R, DVD-R DL, or DVD+R DL discs.

 **NOTE:** Read-write discs, such as CD-RW, DVD±RW, double-layer DVD ±RW, and BD-RE (rewritable Blu-ray) discs, are not compatible with the HP Recovery Manager software.

- The computer must be connected to AC power during this process.
- Only one set of recovery discs or one recovery flash drive can be created per computer.

 **NOTE:** If you are creating recovery discs, number each disc before inserting it into the optical drive.

- If necessary, you can exit the program before you have finished creating the recovery discs or recovery flash drive. The next time you open HP Recovery Manager, you will be prompted to continue the backup creation process.

To create a set of recovery discs or a recovery flash drive:

1. Select **Start > All Programs > HP > HP Recovery Manager > HP Recovery Media Creation**.
2. Follow the on-screen instructions.

Performing a system restore

HP Recovery Manager software allows you to repair or restore the computer to its original factory state. HP Recovery Manager works from recovery discs or a recovery flash drive, or from a dedicated recovery partition (select models only) on the hard drive.

 **NOTE:** A system restore needs to be performed if the computer hard drive has failed or if all attempts to correct any functional computer issues fail. A system restore should be used as a final attempt to correct computer issues.

Note the following when performing a system restore:

- You can restore only the system that you have previously backed up. HP recommends that you use Recovery Manager to create either a set of recovery discs or a recovery flash drive as soon as you set up the computer.
- Windows has its own built-in repair features, such as System Restore. If you have not already tried these features, try them before using HP Recovery Manager.
- HP Recovery Manager restores only software that was preinstalled at the factory. Software not provided with this computer must be downloaded from the manufacturer's Web site or reinstalled from the disc provided by the manufacturer.

Restoring using the dedicated recovery partition (select models only)

When using the dedicated recovery partition, there is an option to back up pictures, music and other audio, videos and movies, recorded TV shows, documents, spreadsheets and presentations, e-mails, and Internet favorites and settings during this process.

To restore the computer from the recovery partition, follow these steps:

1. Access HP Recovery Manager in either of the following ways:
 - Select **Start > All Programs > HP > HP Recovery Manager > HP Recovery Manager**.
 - or –
 - Turn on or restart the computer, and then press **esc** while the “Press the ESC key for Startup Menu” message is displayed at the bottom of the screen. Then, press **f11** while the “F11 (System Recovery)” message is displayed on the screen.
2. Click **System Recovery** in the HP Recovery Manager window.
3. Follow the on-screen instructions.

Restoring using the restore media

1. If possible, back up all personal files.
2. Insert the first recovery disc into the optical drive on your computer or an optional external optical drive, and then restart the computer.
 - or –
 - Insert the recovery flash drive into a USB port on your computer, and then restart the computer.



NOTE: If the computer does not automatically restart in HP Recovery Manager, the computer boot order needs to be changed.

3. Press **f9** at system bootup.

4. Select the optical drive or the flash drive.
5. Follow the on-screen instructions.

Changing the computer boot order

To change the boot order for recovery discs:

1. Restart the computer.
2. Press **esc** while the computer is restarting, and then press **f9** for boot options.
3. Select **Internal CD/DVD ROM Drive** from the boot options window.

To change the boot order for a recovery flash drive:

1. Insert the flash drive into a USB port.
2. Restart the computer.
3. Press **esc** while the computer is restarting, and then press **f9** for boot options.
4. Select the flash drive from the boot options window.

Backing up and recovering your information

It is very important to back up your files and keep any new software in a safe place. As you add new software and data files, continue to create backups on a regular basis.

How completely you are able to recover your system depends on how recent your backup is.



NOTE: A recovery from your most recent backup needs to be performed if the computer has a virus attack or if any major system components fail. In order to correct computer issues, a recovery should first be attempted before a system restore is attempted.

You can back up your information to an optional external hard drive, a network drive, or discs. Back up your system at the following times:

- At regularly scheduled times



TIP: Set reminders to back up your information periodically.

- Before the computer is repaired or restored
- Before you add or modify hardware or software

Guidelines:

- Create system restore points using the Windows® System Restore feature, and periodically copy them to an optical disc or an external hard drive. For more information on using system restore points, refer to [Using Windows system restore points on page 53](#).
- Store personal files in the Documents library and back up this folder periodically.
- Save customized settings in a window, toolbar, or menu bar by taking a screen shot of your settings. The screen shot can be a time-saver if you have to re-enter your preferences.

To create a screen shot:

1. Display the screen you want to save.
2. Copy the screen image:
To copy only the active window, press [alt+prt sc](#).
To copy the entire screen, press [prt sc](#).
3. Open a word-processing document, and then select **Edit > Paste**. The screen image is added to the document.
4. Save and print the document.

Using Windows Backup and Restore

Guidelines:

- Be sure that the computer is connected to AC power before you start the backup process.
- Allow enough time to complete the backup process. Depending on file sizes, it may take over an hour.

To create a backup:

1. Select **Start > Control Panel > System and Security > Backup and Restore**.
2. Follow the on-screen instructions to schedule and create a backup.



NOTE: Windows® includes the User Account Control feature to improve the security of the computer. You may be prompted for your permission or password for tasks such as installing software, running utilities, or changing Windows settings. Refer to Help and Support for more information.

Using Windows system restore points

A system restore point allows you to save and name a snapshot of your hard drive at a specific point in time. You can then recover back to that point if you want to reverse subsequent changes.



NOTE: Recovering to an earlier restore point does not affect data files saved or e-mails created since the last restore point.

You also can create additional restore points to provide increased protection for your files and settings.

When to create restore points

- Before you add or modify software or hardware
- Periodically, whenever the computer is functioning optimally



NOTE: If you revert to a restore point and then change your mind, you can reverse the restoration.

Create a system restore point

1. Select **Start > Control Panel > System and Security > System**.
2. In the left pane, click **System Protection**.
3. Click the **System Protection** tab.
4. Follow the on-screen instructions.

Restore to a previous date and time

To revert to a restore point (created at a previous date and time), when the computer was functioning optimally, follow these steps:

1. Select **Start > Control Panel > System and Security > System**.
2. In the left pane, click **System Protection**.
3. Click the **System Protection** tab.
4. Click **System Restore**.
5. Follow the on-screen instructions.

7 Customer support

Contacting customer support

If the information provided in this user guide, in the *HP Notebook Reference Guide*, or in Help and Support does not address your questions, you can contact HP Customer Support at:

<http://www.hp.com/go/contactHP>



NOTE: For worldwide support, click **Contact HP worldwide** on the left side of the page, or go to http://welcome.hp.com/country/us/en/wwcontact_us.html.

Here you can:

- Chat online with an HP technician.



NOTE: When technical support chat is not available in a particular language, it is available in English.

- E-mail HP Customer Support.
- Find HP Customer Support worldwide telephone numbers.
- Locate an HP service center.

Labels

The labels affixed to the computer provide information you may need when you troubleshoot system problems or travel internationally with the computer:

- Serial number label—Provides important information, including the following:

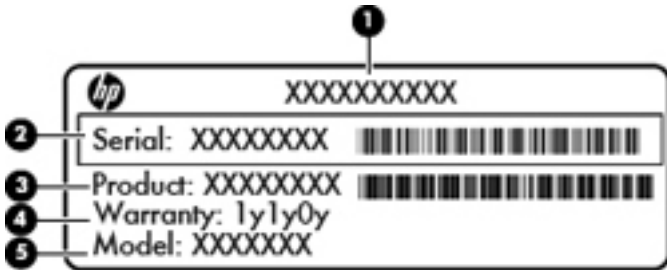

Component

-
- | | |
|-----|----------------------------------|
| (1) | Product name |
| (2) | Serial number (s/n) |
| (3) | Part number/Product number (p/n) |
-

(4) Warranty period

(5) Model description

Have this information available when you contact technical support. The serial number label is affixed inside the battery bay.

- Microsoft® Certificate of Authenticity—Contains the Windows Product Key. You may need the Product Key to update or troubleshoot the operating system. The Microsoft Certificate of Authenticity is located on the bottom of the computer.
- Regulatory label—Provides regulatory information about the computer. The regulatory label is affixed inside the battery bay.
- Wireless certification label or labels (select models only)—Provide information about optional wireless devices and the approval markings of some of the countries or regions in which the devices have been approved for use. If your computer model includes one or more wireless devices, one or more certification labels are included with your computer. You may need this information when traveling internationally. Wireless certification labels are affixed inside the battery bay.

8 Specifications

- [Input power](#)
- [Operating environment](#)

Input power

The power information in this section may be helpful if you plan to travel internationally with the computer.

The computer operates on DC power, which can be supplied by an AC or a DC power source. The AC power source must be rated at 100–240 V, 50–60 Hz. Although the computer can be powered from a standalone DC power source, it should be powered only with an AC adapter or a DC power source supplied and approved by HP for use with this computer.

The computer can operate on DC power within the following specifications.

Input power	Rating
Operating voltage and current	19.5 V dc @ 6.5 A - 120 W

DC plug of external HP power supply



 **NOTE:** This product is designed for IT power systems in Norway with phase-to-phase voltage not exceeding 240 V rms.

 **NOTE:** The computer operating voltage and current can be found on the system regulatory label.

Operating environment

Factor	Metric	U.S.
Temperature		
Operating (writing to optical disc)	5°C to 35°C	41°F to 95°F
Nonoperating	-20°C to 60°C	-4°F to 140°F
Relative humidity (noncondensing)		
Operating	10% to 90%	10% to 90%
Nonoperating	5% to 95%	5% to 95%
Maximum altitude (unpressurized)		
Operating	-15 m to 3,048 m	-50 ft to 10,000 ft
Nonoperating	-15 m to 12,192 m	-50 ft to 40,000 ft

A RAID 0 (select models only)

Select computer models with two hard drives ship in a RAID 0 configuration. RAID benefits users who frequently work with large files and want to improve the storage performance of their computer. With RAID 0, data is distributed across both drives. This allows data, especially large files, to be read faster, because data is read simultaneously from both drives. However, RAID 0 offers no fault tolerance, which means that the entire array fails if one drive fails.

To enhance the write performance of RAID 0, Intel® Rapid Storage Technology has implemented a volume write-back cache. The volume write-back cache allows writes to be buffered and improves coalescing. The cache is enabled by default and can be disabled or reenabled in Intel Rapid Storage Technology. An Uninterrupted Power Supply (UPS) is recommended for use if the cache is enabled.

Disabling RAID 0

 **CAUTION:** Disabling RAID 0 completely erases hard drive contents and reformats the hard drive. All files you have created and any software installed on the computer are permanently removed. Before you disable RAID 0, be sure to back up your information and create a set of recovery discs. Refer to [Backup and recovery on page 48](#) for additional information.

To disable RAID 0:

1. Create a set of recovery discs. The hard drive contents will be completely erased after disabling RAID 0. Refer to [Backup and recovery on page 48](#) for more information.

For a full image recovery, be sure that you have the service recovery discs. For a minimized factory image recovery, be sure that you have the set of recovery discs you created with Recovery Manager.



NOTE: Make sure that you back up all personal files. Software not provided with this computer must be downloaded from the manufacturer's Web site or reinstalled from the disc provided by the manufacturer.

2. Turn on or restart the computer. While the "Press the ESC key for Startup Menu" message is displayed in the lower-left corner of the screen, press **esc**. When the Startup Menu is displayed, press **f10**.
3. Use the arrow keys to select **System Configuration**, and then change **RAID OROM UI** to **enable**.
4. Use the arrow keys to select **Exit > Exit Saving Changes**, and then click **Yes** to save your change and restart the computer.
5. When the POST screen opens, press **ctrl+I** to enter the configuration utility.
6. In the **Main** menu, use the up or down arrow key to select **3. Reset Disks to Non-RAID**, and then press **enter**. The Reset RAID Data window is displayed.
7. Press the spacebar to select the first hard drive, and then press the down arrow key and the spacebar to select the second hard drive.

8. Press **enter**, and then press **Y** to confirm the selection.



CAUTION: Once you confirm the selection, your hard drive contents are completely erased and the hard drive is reformatted.

9. Use the down arrow key to select **5. Exit**.
10. Press **enter**, and then press **Y**. You will see the "No bootable device" message displayed on the screen.
11. Insert the first service recovery disc or the first recovery disc you created, and then reboot the computer.
12. Press **F9** for the boot option menu, and then select Internal CD/DVD ROM Drive as the boot device.
13. If you used the set of service recovery discs, follow the on-screen instructions to complete the recovery.

-or-

If you used the set of recovery discs you created, select Minimized System Recovery, and then follow the on-screen instructions to complete the recovery.

Index

A

- action keys
 - adjusting volume 25
 - Help and Support 24
 - identifying 11
 - keyboard backlight 25
 - muting speaker sound 25
 - screen brightness down 24
 - screen brightness up 24
 - switching screen image 25
 - using 24
 - wireless 25
- AMD Catalyst Control Center 5
- AMD Eyefinity 4
- audio-in (microphone) jack, identifying 16
- audio-out (headphone) jack, identifying 16

B

- backing up
 - customized window, toolbar, and menu bar settings 52
 - personal files 52
- bass settings hotkey 26
- battery bay 56
- battery bay, identifying 19
- battery light 13
- battery release latch 20
- battery, replacing 34
- bays
 - battery 19, 56
 - hard drive 20
- Beats Audio 3, 26
- Bluetooth label 56
- buttons 10
 - left TouchPad 8
 - right TouchPad 8

C

- caps lock light, identifying 9
- Certificate of Authenticity label 56
- components
 - bottom 19
 - display 17
 - front 12
 - left-side 15
 - right-side 13
 - top 8
- connector, power 14

D

- DC plug of external HP power supply 57
- Digital Media Slot, identifying 13
- display image, switching 25
- drives, hard 38

E

- eSATA port, identifying 15
- esc key, identifying 11
- external monitor port, identifying 15
- Eyefinity 4

F

- f11 50
- flicking TouchPad gesture 33
- fn key, identifying 11, 26

G

- graphics modes, switching 2

H

- hard drive
 - installing 38
 - removing 36
- hard drive bay, identifying 20
- hard drive light 12
- HDMI port, identifying 15
- headphone (audio-out) jack 16
- Help and Support key 24
- hotkeys
 - bass settings 26
 - description 26
 - display system information 26
 - using 26
- HP Recovery Manager 49

I

- input power 57
- integrated numeric keypad, identifying 11, 27
- integrated webcam light, identifying 17
- internal display switch, identifying 18
- internal microphones, identifying 17
- Internet connection setup 22
- ISP, using 21

J

- jacks
 - audio-in (microphone) 16

- audio-out (headphone) 16
- RJ-45 (network) 15

K

- keyboard backlight action key 25
- keyboard hotkeys, identifying 26
- keypad, integrated 11, 27
- keys
 - action 11
 - esc 11
 - fn 11
 - optical drive eject 11
 - Windows applications 11
 - Windows logo 11

L

- labels
 - Bluetooth 56
 - Microsoft Certificate of Authenticity 56
 - regulatory 56
 - serial number 55
 - wireless certification 56
 - WLAN 56
- latch, battery release 20
- lights
 - battery 13
 - caps lock 9
 - hard drive 12
 - mute 9
 - power 9, 12
 - TouchPad 8, 9
 - webcam 17
 - wireless 9

M

- memory module
 - inserting 43
 - removing 42
 - replacing 40
- memory module compartment cover
 - removing 42
 - replacing 44
- memory module compartment, identifying 19
- microphone (audio-in) jack, identifying 16
- Microsoft Certificate of Authenticity label 56
- Mini DisplayPort, identifying 15
- mouse, external
 - setting preferences 27
- mute key, identifying 25
- mute light, identifying 9

N

- network jack, identifying 15

O

- operating environment 58
- operating system
 - Microsoft Certificate of Authenticity label 56
 - Product Key 56
- optical drive eject key, identifying 11
- optical drive, identifying 13

P

- pinching TouchPad gesture 31
- pointing devices, setting preferences 27
- ports
 - eSATA 15
 - external monitor 15
 - HDMI 15
 - SuperSpeed USB 15
 - USB 13
- power button, identifying 10
- power connector, identifying 14
- power lights, identifying 9, 12
- Product Key 56
- product name and number, computer 55

R

- RAID 0 59
- recovering from the dedicated recovery partition 50
- recovering from the recovery discs 50
- recovery discs 48
- recovery, system 49
- regulatory information
 - regulatory label 56
 - wireless certification labels 56
- restore points 53
- RJ-45 (network) jack, identifying 15
- rotating TouchPad gesture 32

S

- screen brightness keys 24
- screen image, switching 25
- scrolling TouchPad gesture 31
- security cable slot, identifying 14
- serial number label 55
- serial number, computer 55
- setup of WLAN 22
- single large surface 4
- slots
 - Digital Media 13
 - security cable 14
- speakers, identifying 12
- subwoofer, identifying 19
- SuperSpeed USB port, identifying 15
- supported discs 49
- switchable graphics 2

- system information hotkey 26
- system recovery 49
- system restore points 53

T

- TouchPad
 - buttons 8
 - using 27
- TouchPad gestures
 - flicking 33
 - pinching 31
 - rotating 32
 - scrolling 31
 - zooming 31
- TouchPad light 8, 9
- TouchPad zone, identifying 8
- traveling with the computer 56

U

- USB ports, identifying 13
- using system restore 53

V

- vents, identifying 15, 19
- volume keys, identifying 25

W

- webcam light, identifying 17
- webcam, identifying 17
- Windows applications key, identifying 11
- Windows logo key, identifying 11
- wireless certification label 56
- wireless key, identifying 25
- wireless light 9
- wireless network (WLAN), equipment needed 22
- wireless network, connecting 22
- wireless router, configuring 23
- wireless setup 22
- WLAN
 - connecting 22
 - protecting 23
- WLAN antennas, identifying 17
- WLAN device 56
- WLAN label 56

Z

- zooming TouchPad gesture 31

