



# HP Retail Mobile POS Case Quick Start Guide



© Copyright 2011 Hewlett-Packard Development Company, L.P.  
Printed in

First Edition: November 2011



676673-001

## Before You Begin

Before assembling the HP Retail Mobile POS Case, consult the readme documentation included with the MSR and barcode scanner drivers. Drivers may be included on a CD that came with the case or they can be downloaded from [www.hp.com](http://www.hp.com).

1. Go to [www.hp.com](http://www.hp.com).
2. Click the **SUPPORT & DRIVERS** link.
3. Click the **Drivers & Software** link.
4. In the **SEARCH** box, enter HP Slate 2 Tablet PC and click the **SEARCH** button.
5. Follow the on-screen instructions.

Before assembling the HP Retail Mobile POS Case be sure to power off the computer.

## Installing the Case

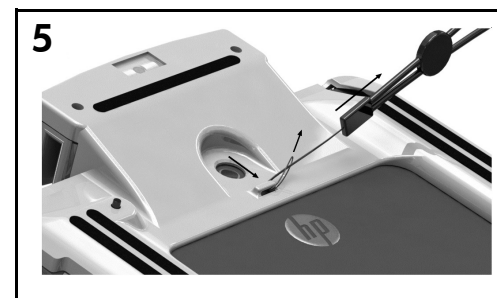
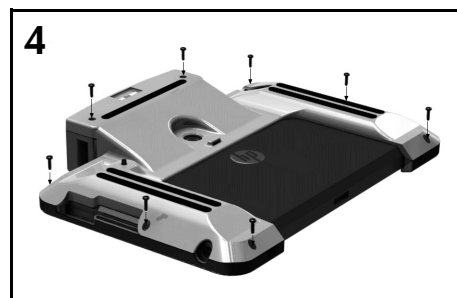
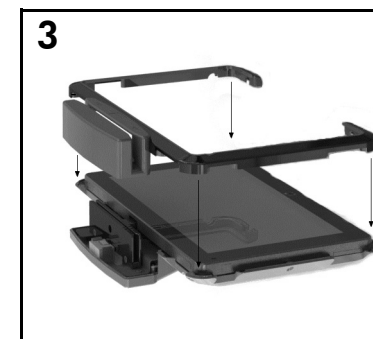
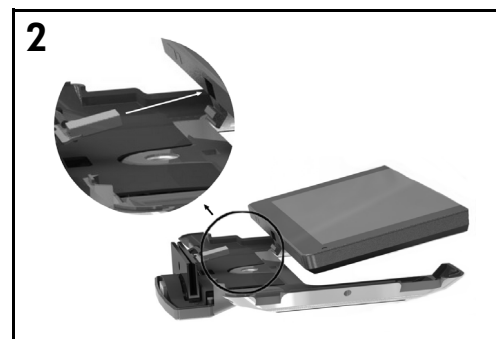
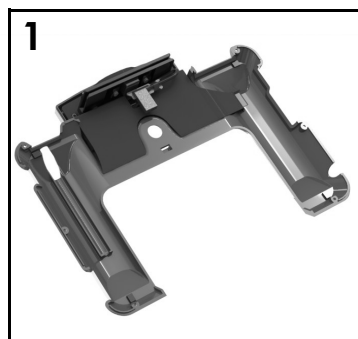

## Removing the Case

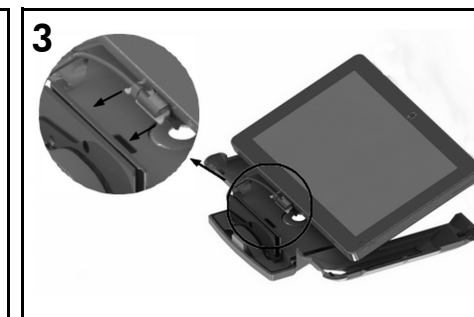
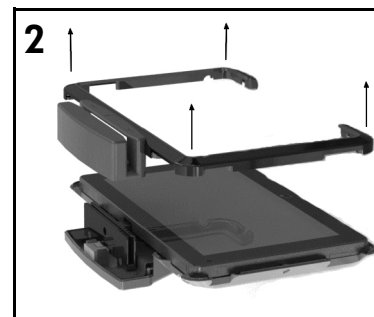
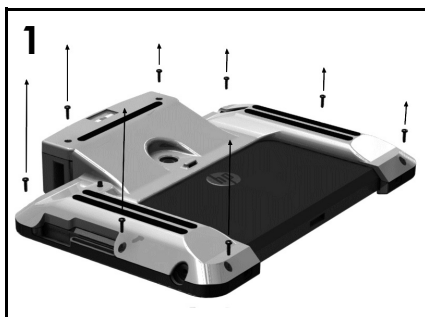

## Using the Scanner

Press the button on the underside of the case to scan.

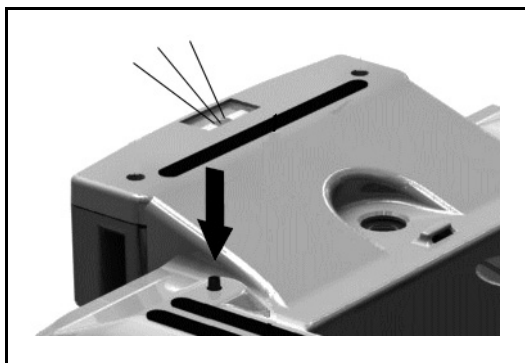

## Online Technical Support

For the online access to technical support information, self-solve tools, online assistance, community forums or IT experts, broad multivendor knowledge base, monitoring and diagnostic tools, go to <http://www.hp.com/support>.

## Federal Communications Commission Notice

This equipment has been tested and found to comply with the limits for a Class B digital device, pursuant to Part 15 of the FCC Rules. These limits are designed to provide reasonable protection against harmful interference in a residential installation. This equipment generates, uses, and can radiate radio frequency energy and, if not installed and used in accordance with the instructions, may cause harmful interference to radio communications. However, there is no guarantee that interference will not occur in a particular installation. If this equipment does cause harmful interference to radio or television reception, which can be determined by turning the equipment off and on, the user is encouraged to try to correct the interference by one or more of the following measures:

- Reorient or relocate the receiving antenna.
- Increase the separation between the equipment and the receiver.
- Connect the equipment into an outlet on a circuit different from that to which the receiver is connected.
- Consult the dealer or an experienced radio or television technician for help.

## Modifications

The FCC requires the user to be notified that any changes or modifications made to this device that are not expressly approved by Hewlett-Packard Company may void the user's authority to operate the equipment.

## Cables

Connections to this device must be made with shielded cables with metallic RFI/EMI connector hoods in order to maintain compliance with FCC Rules and Regulations.

## Declaration of Conformity for Products Marked with the FCC Logo (United States Only)

This device complies with Part 15 of the FCC Rules. Operation is subject to the following two conditions:

1. This device may not cause harmful interference.
2. This device must accept any interference received, including interference that may cause undesired operation.

For questions regarding the product, contact:

Hewlett Packard Company  
P. O. Box 692000, Mail Stop 530113  
Houston, Texas 77269-2000  
Or, call 1-800-HP-INVENT (1-800 474-6836)

For questions regarding this FCC declaration, contact:

Hewlett Packard Company  
P. O. Box 692000, Mail Stop 510101  
Houston, Texas 77269-2000  
Or, call (281) 514-3333

To identify this product, refer to the Part, Series, or Model number found on the product.

## Canadian Notice

This Class B digital apparatus complies with Canadian ICES-003.

## Avis Canadien

Cet appareil numérique de la classe B est conforme à la norme NMB-003 du Canada.