



UPGRADING AND SERVICING GUIDE



Copyright © 2011 Hewlett-Packard Development Company, L.P.

The information contained herein is subject to change without notice.

Part Number: 655123-003

Version: 1.0

Upgrading and Servicing Guide

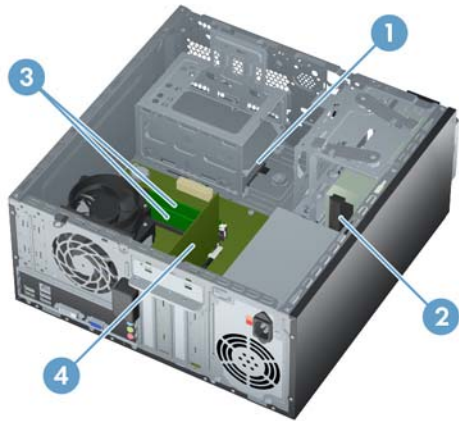

Computer features may vary by model.

- [Removing and Replacing a Hard Disk Drive on page 2](#)
- [Removing and Replacing a CD/DVD Drive on page 9](#)
- [Upgrading and Replacing Memory on page 15](#)
- [Removing and Replacing an Add-in Card on page 19](#)
- [Removing and Replacing a Power Supply on page 24](#)

Removing and Replacing a Hard Disk Drive

Computer features may vary by model.



15 - 20 minutes

Before you begin

Observe the following requirements before removing and replacing the hard disk drive.

⚠ WARNING! Never open the cover with the power applied. You might damage your computer or be injured by the spinning the fan blades.

⚠ WARNING! Avoid touching sharp edges inside the computer.

⚠ WARNING! Keep your hands away from the moving fan.

⚠ WARNING! Keep fingers and tools clear of the fan when the power is applied.

⚠ CAUTION: Static electricity can damage the electronic components inside the computer. Discharge static electricity by touching the metal cage of the computer before touching any internal parts or electronic components.

🔧 IMPORTANT: A hard disk drive is extremely sensitive to shock impact. Do not bang or drop it. Do not touch the circuit board. Static electricity can damage the drive.

Tools Needed

- Flathead/T15 Torx screwdriver

Small screws are easily lost. Remove screws over a surface that enables you to retrieve them if they fall.

Removing the hard disk drive

1. Remove any media or storage devices such as CDs, DVDs, and USB.
2. Close all programs, and then shut down your operating system.
3. Unplug the computer by disconnecting the power cord and all attached cables from the back of the computer.



4. Using a flathead or Torx screwdriver, loosen the screw on the back panel that secures the panel to the computer.



5. Slide the side panel toward the back of the computer.



6. Pull the side panel away from the computer.



7. Release the three tabs on the front bezel by lifting them away from the computer.



8. Open the front bezel.



9. Remove the bezel from the computer.

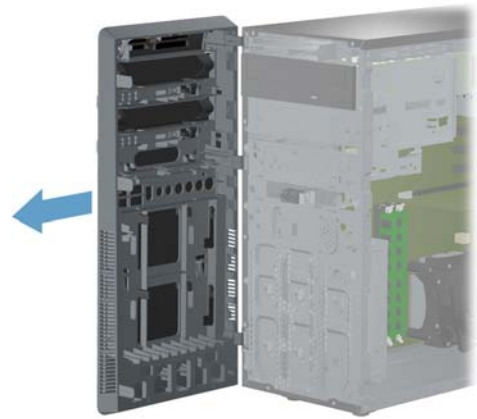

10. Locate hard disk drive in the computer.



11. Lay the computer on a flat surface.



12. Remove the two screws that secure the hard disk drive cage to the computer.

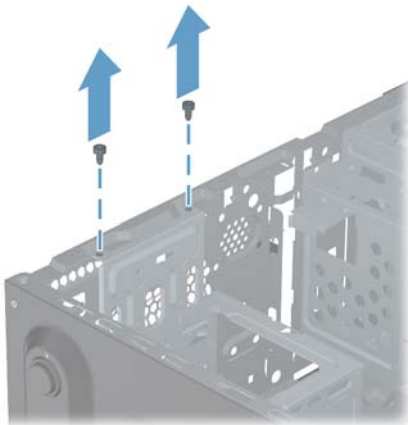

13. Using a screwdriver, push the lever marked "1" on the base on the right side of the hard disk drive cage by the motherboard.

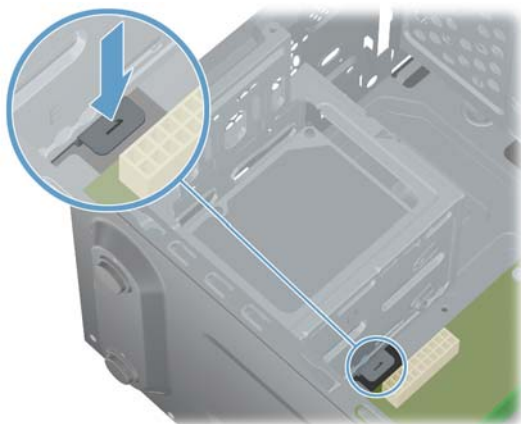

14. Grasp the hard drive cage and slide the cage toward the CD/DVD drive, and then lift the cage out of the computer.

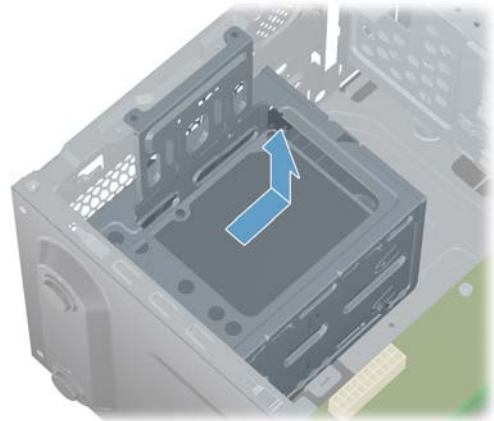

15. Disconnect the two cables from the end of the hard disk drive. The cables may have a latch that is pressed to release the cable.

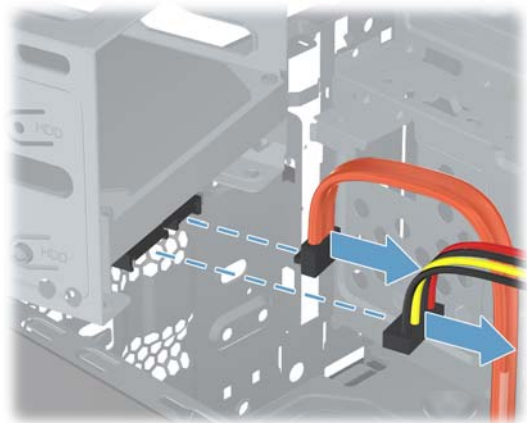

- 16.** The cage may contain one or two hard disk drives. Each drive has two screws on each side of the cage.

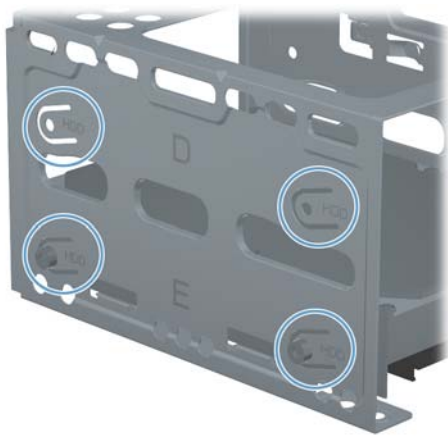
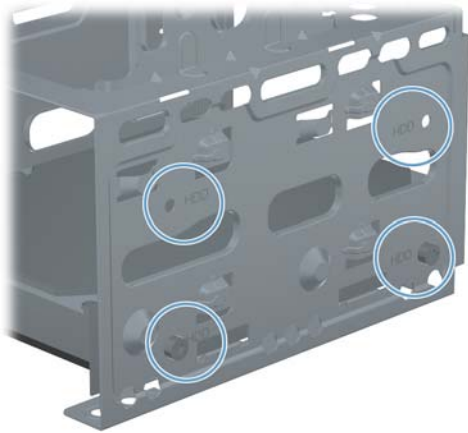

- 17.** Remove the four screws that secure the hard disk drive to the cage.

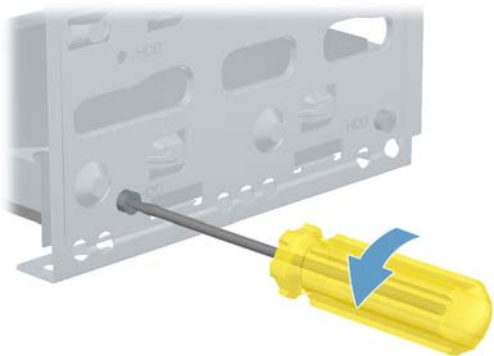

- 18.** Slide the hard disk drive out of the cage.

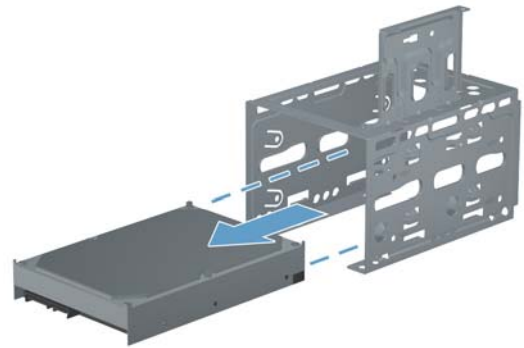

 **NOTE:** Keep the four screws available as they will be used in the new hard drive.

Installing a new hard disk drive

 **NOTE:** The replacement part may look different than the original part because of manufacturer or model differences; however, the replacement part meets or exceeds the specifications of the original part.

- 1.** Insert the new hard drive into the hard drive cage, making sure the connectors on the hard drive are on the same end of the cage as the handle. The hard drive will rest on the metal tabs located inside the cage.

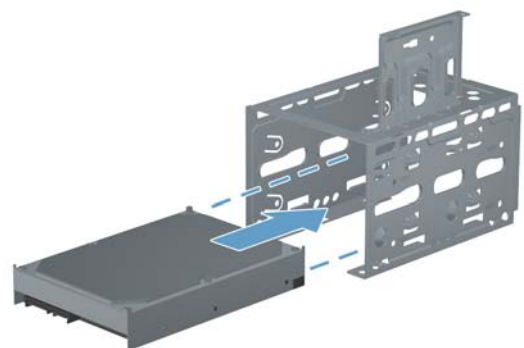

- 2.** Align the screw holes on the hard disk drive with the screw holes on the cage.

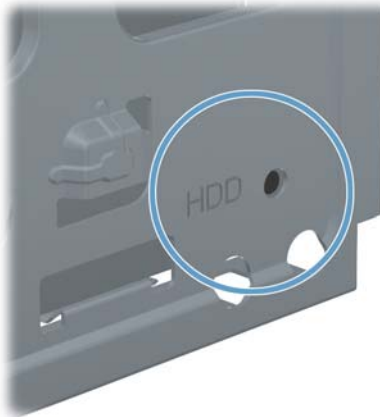

- 3.** Replace the four screws, two on each side of the cage, to secure the hard disk drive in the cage.

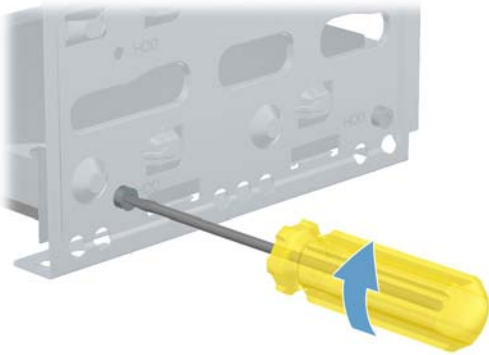

- 4.** Reattach the cables to the end of the hard disk drive.

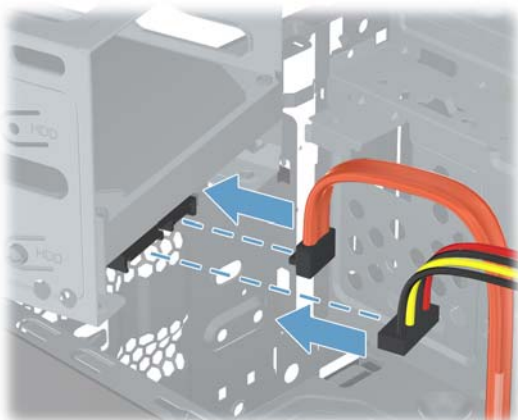

- 5.** Set the hard drive cage down into the bay, aligning the tabs on the bottom of the cage with the tabs on the chassis.

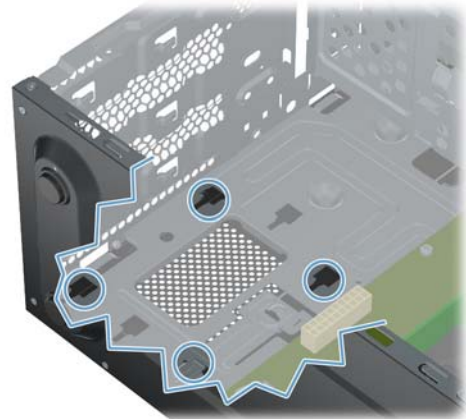

- 6.** Press down and slide the cage to lock it in place.

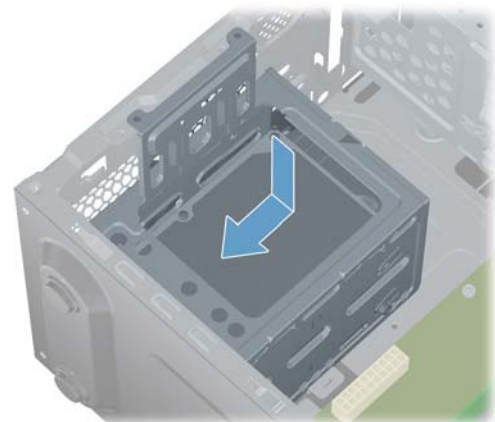

- 7.** Insert the two screws to secure the cage to the computer.

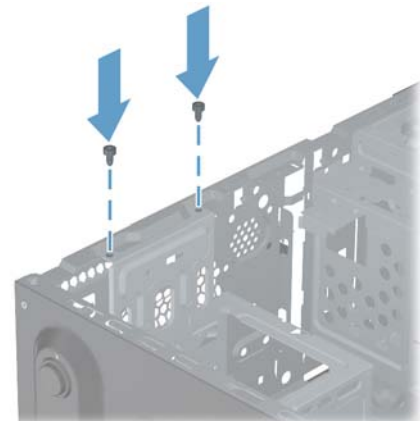

8. Place the computer in an upright position.
9. Reattach the front bezel by inserting the three tabs into the slots on the computer.



10. Close the bezel door until it locks in place.



11. Install the side panel on the side of the computer, and then slide it toward the front of the computer.



NOTE: Make sure the panel is flush with the computer. Failure to do so might cause the panel to bend slightly outward and not close securely.

12. Tighten the screw, securing the side panel to the back of the computer.

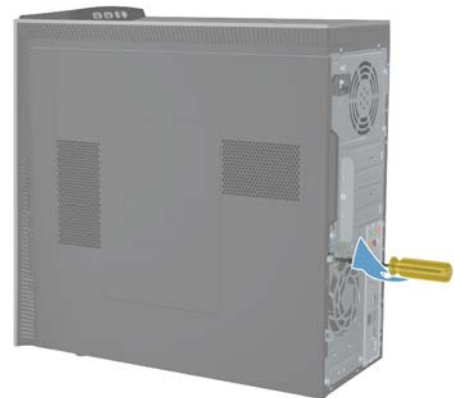

- 13.** Plug the power cord and any additional cables into the back of the computer.



- 14.** Press the power button to turn on the computer.



 **NOTE:** If your hard disk drive was shipped without an operating system installed, you will need to reinstall it using the system recovery discs.

To install the operating system, refer to the instructions included with your system recovery discs, or available from the HP support site (www.hp.com/support).

After the operating system has been installed, you will need to reinstall any applications and restore any data you backed up.

TASK COMPLETED

Printed in:

Removing and Replacing a CD/DVD Drive

Computer features may vary by model.



10 – 15 minutes

Before you begin

Observe the following requirements before removing and replacing the CD/DVD drive.

WARNING! Never open the cover with the power applied. You might damage your computer or be injured by the spinning the fan blades.

WARNING! Avoid touching sharp edges inside the computer.

WARNING! Keep your hands away from the moving fan.

WARNING! Keep fingers and tools clear of the fan when the power is applied.

CAUTION: Static electricity can damage the electronic components inside the computer. Discharge static electricity by touching the metal cage of the computer before touching any internal parts or electronic components.

IMPORTANT: A CD/DVD drive is extremely sensitive to shock impact. Do not bang or drop it.

Tools Needed

- Flathead/T15 Torx screwdriver

Small screws are easily lost. Remove screws over a surface that enables you to retrieve them if they fall.

Removing the CD/DVD drive

1. Remove any media or storage devices such as CDs, DVDs, and USB.
2. Close all programs, and then shut down your operating system.
3. Unplug the computer by disconnecting the power cord and all attached cables from the back of the computer.



4. Using a flathead or Torx screwdriver, loosen the screw on the back panel that secures the panel to the computer.



5. Slide the side panel toward the back of the computer.



6. Pull the side panel away from the computer.



7. Release the three tabs on the front bezel by lifting them away from the computer.



8. Open the front bezel.



9. Remove the bezel from the computer.

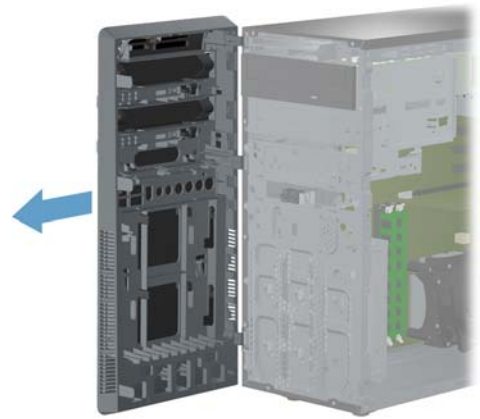

10. Locate the CD/DVD drives on the computer.

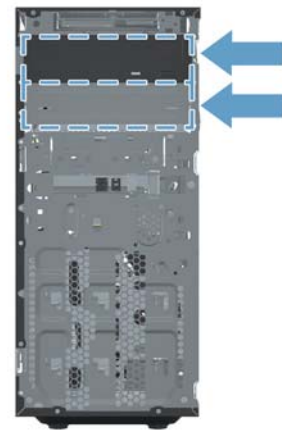

- 11.** To unlock the CD/DVD drive, pull "Lever A" slightly out and to the left, and then release the lever in the center position. Numbers "1" and "2" will both be exposed.



If you have more than one CD/DVD drive to remove, repeat this step. However, instead of moving "Lever A", move "Lever B."

- 12.** Push the CD/DVD drive slightly forward.

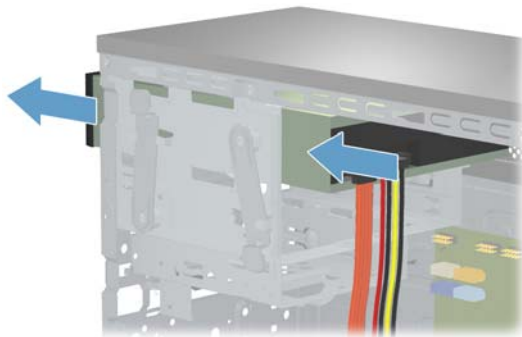

- 13.** Disconnect the two cables from the back of the CD/DVD drive. The cables may have a latch that is pressed to release the cable.

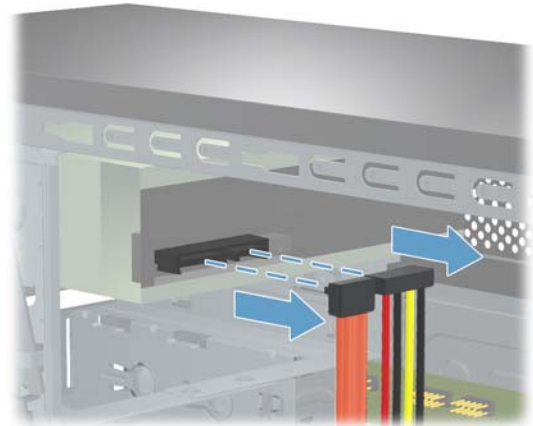

- 14.** Pull the CD/DVD drive out from the front of the computer.

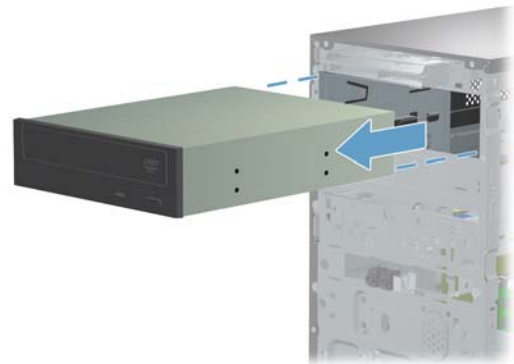

Installing a CD/DVD drive

NOTE: The replacement part may look different than the original part because of manufacturer or model differences; however, the replacement part meets or exceeds the specifications of the original part.

1. Locate where the CD/DVD drive is to be inserted.

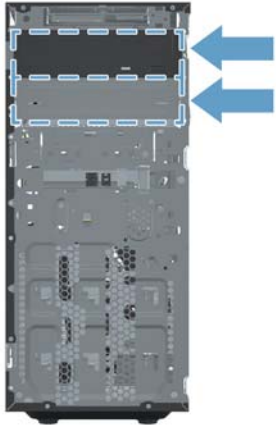

2. Insert the new CD/DVD drive into the slot and slide it back partially into the computer.

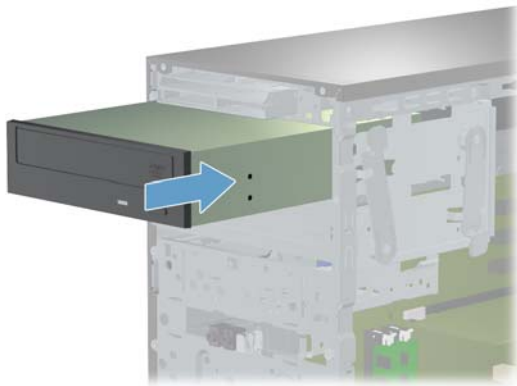

3. Slide the CD/DVD drive back all the way into the slot.



4. To lock the CD/DVD drive into place, move "Lever A" to the number "2" position. Slide the CD/DVD drive out slightly until "Lever A" latches into position to secure the drive.



If you have more than one CD/DVD drive to install, repeat this step. However, instead of moving "Lever A", move "Lever B."

5. Connect the cables to the back of the CD/DVD drive.

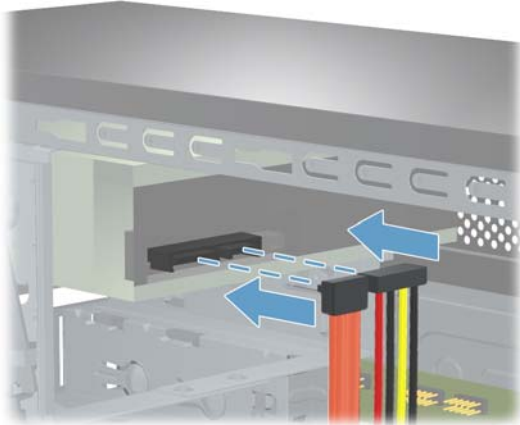

6. Reattach the front bezel by inserting the three tabs into the slots on the computer.



7. Close the bezel door until it locks in place.



8. Install the side panel on the side of the computer, and then slide it toward the front of the computer.



NOTE: Make sure the panel is flush with the computer. Failure to do so might cause the panel to bend slightly outward and not close securely.

9. Tighten the screw, securing the side panel to the back of the computer.

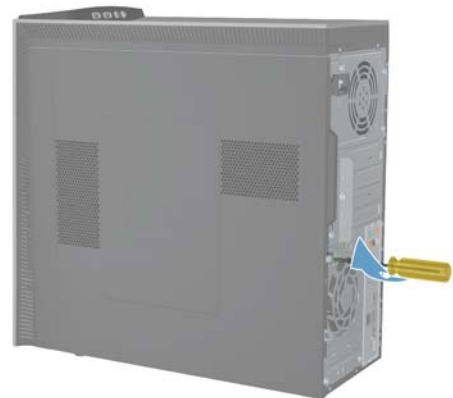

- 10.** Plug the power cord and any additional cables into the back of the computer.

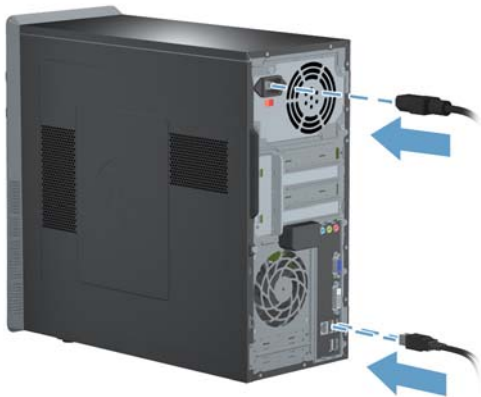

- 11.** Press the power button to turn on the computer.



TASK COMPLETED

Printed in:

Upgrading and Replacing Memory

Computer features may vary by model.

The memory performance may vary due to different system configurations.



10 – 15 minutes

Before you begin

Observe the following requirements before removing and replacing memory.

WARNING! Never open the cover with the power applied. You might damage your computer or be injured by the spinning the fan blades.

WARNING! Avoid touching sharp edges inside the computer.

WARNING! Keep your hands away from the moving fan.

WARNING! Keep fingers and tools clear of the fan when the power is applied.

CAUTION: Static electricity can damage the electronic components inside the computer. Discharge static electricity by touching the metal cage of the computer before touching any internal parts or electronic components.

IMPORTANT: A memory card is extremely sensitive to shock impact. Do not bang or drop it. Static electricity can damage the card.

Tools Needed

- Flathead/T15 Torx screwdriver

Small screws are easily lost. Remove screws over a surface that enables you to retrieve them if they fall.

Memory Compatibility

Verify that the memory installed is compatible with this computer. SO-DIMMs are small outline dual inline memory modules. They are smaller and thinner than most other DIMMs, so that they take less space in the case. SO-DIMM modules must meet the following requirements:

- 240-pin DDR3-DIMM
- PC3-10600 (1333 MHz) DDR3-SDRAM
- Unbuffered, non-ECC (64-bit) DIMMs
- 1.5 V memory only
- 16.0 GB maximum installable memory using 4GB Modules. Actual available memory that can be used in Windows will be less.

Because the memory uses dual channels, you should use the same DIMM type for both sockets.

NOTE: The actual memory transfer speed can vary based on the CPU used in your computer.

Removing the memory

- Remove any media or storage devices such as CDs, DVDs, and USB.
- Close all programs, and then shut down your operating system.
- Unplug the computer by disconnecting the power cord and all attached cables from the back of the computer.



- 4.** Using a flathead or Torx screwdriver, loosen the screw on the back panel that secures the panel to the computer.



- 5.** Slide the side panel toward the back of the computer.



- 6.** Pull the side panel away from the computer.



- 7.** Lay the computer on a flat surface.



- 8.** Locate the memory in the computer.

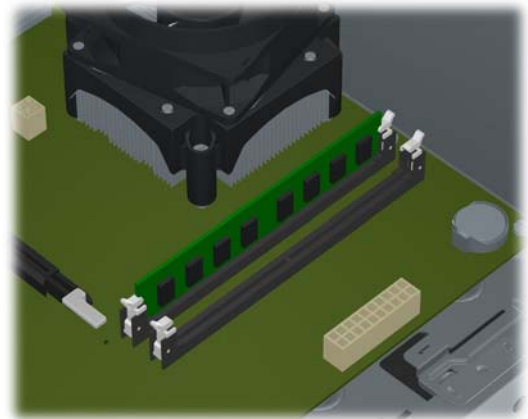

- 9.** To release the memory card, press outwards on the retaining clips on the left and right sides of the memory card.

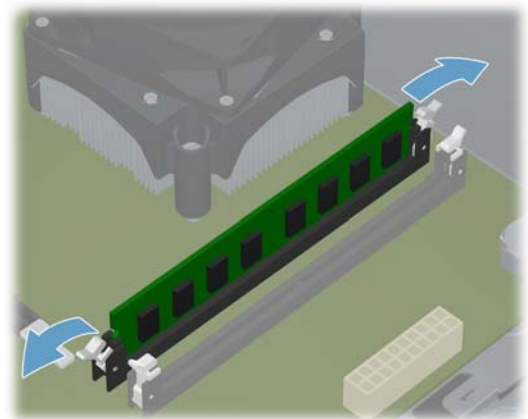

10. Holding the memory card by the edges, gently remove it from the slot.

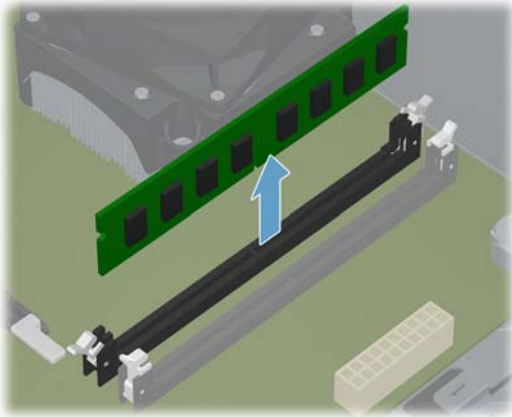

11. To remove additional memory cards, repeat steps 9 and 10.

Installing a memory card

NOTE: The replacement part may look different than the original part because of manufacturer or model differences; however, the replacement part meets or exceeds the specifications of the original part.

1. Orient the new memory card so that the notch in the memory card aligns with the tab in the socket.



2. Holding the memory card by the edges, press the card into the socket. Make sure the memory card is pressed completely into the socket, and then gently push down on the card until the retaining clips snap into place.

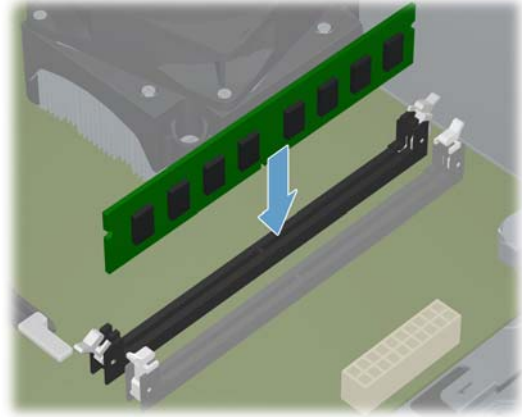

3. If you are replacing more than one memory card, repeat step 2 for the second memory card.
4. Place the computer in an upright position.
5. Install the side panel on the side of the computer, and then slide it toward the front of the computer.



NOTE: Make sure the panel is flush with the computer. Failure to do so might cause the panel to bend slightly outward and not close securely.

6. Tighten the screw, securing the side panel to the back of the computer.



7. Plug the power cord and any additional cables into the back of the computer.



8. Press the power button to turn on the computer.



Troubleshooting

If the computer displays a memory error after you have turned it back on:

1. Turn the computer off and unplug the power cord.
2. Open up the memory compartment and make sure the memory card is firmly seated.
3. To install the memory card correctly, make sure it is inserted all the way into the compartment and then push down on it to snap it into place.

Printed in:

Removing and Replacing an Add-in Card

Computer features may vary by model.



10 – 15 minutes

Before you begin

Observe the following requirements before removing and replacing the add-in card.

- WARNING!** Never open the cover with the power applied. You might damage your computer or be injured by the spinning the fan blades.
- WARNING!** Avoid touching sharp edges inside the computer.
- WARNING!** Keep your hands away from the moving fan.
- WARNING!** Keep fingers and tools clear of the fan when the power is applied.
- CAUTION:** Static electricity can damage the electronic components inside the computer. Discharge static electricity by touching the metal cage of the computer before touching any internal parts or electronic components.
- IMPORTANT:** An add-in card is extremely sensitive to shock impact. Do not bang or drop it. Static electricity can damage the card.

Tools Needed

- Flathead/T15 Torx screwdriver

Small screws are easily lost. Remove screws over a surface that enables you to retrieve them if they fall.

Removing the add-in card

1. Remove any media or storage devices such as CDs, DVDs, and USB.
2. Close all programs, and then shut down your operating system.
3. Unplug the computer by disconnecting the power cord and all attached cables from the back of the computer.



4. Using a flathead or Torx screwdriver, loosen the screw on the back panel that secures the panel to the computer.



5. Slide the side panel toward the back of the computer.



6. Pull the side panel away from the computer.



7. Lay the computer on a flat surface.



8. Locate the add-in cards on the computer.

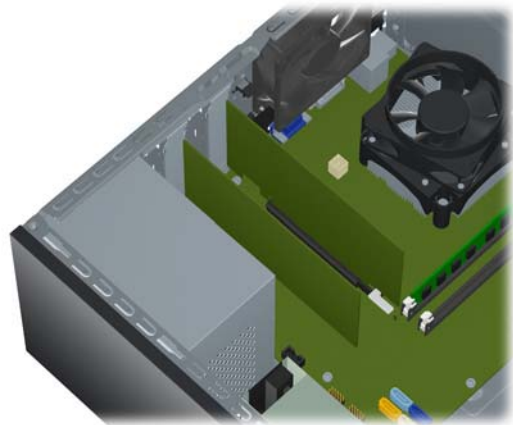

9. On the back of the computer, remove the screw holding the add-in card bracket in place.

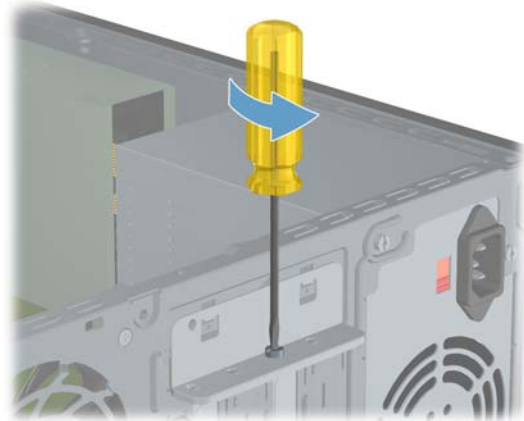

10. Remove the bracket from the back of the computer.

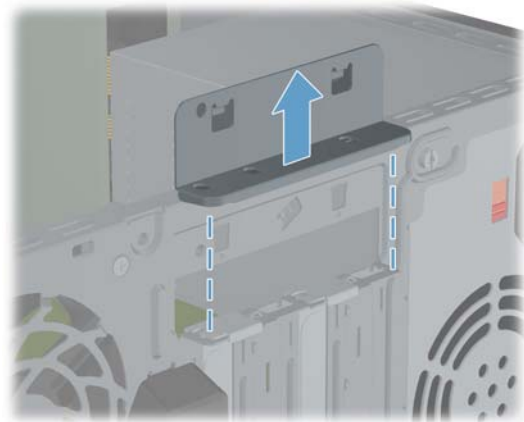

11. To make it easier to access the add-in cards, disconnect the auxiliary power cable from the motherboard.

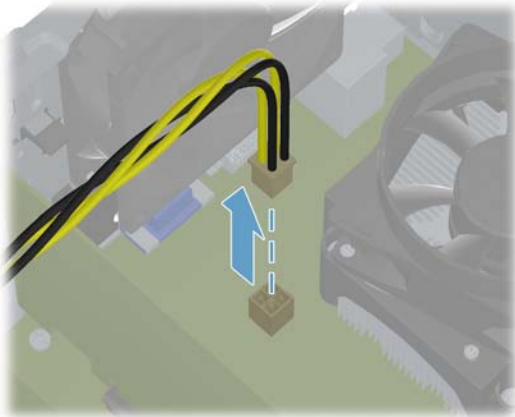

12. If the add-in card is in the large slot (graphics card), press the latch to release the card.

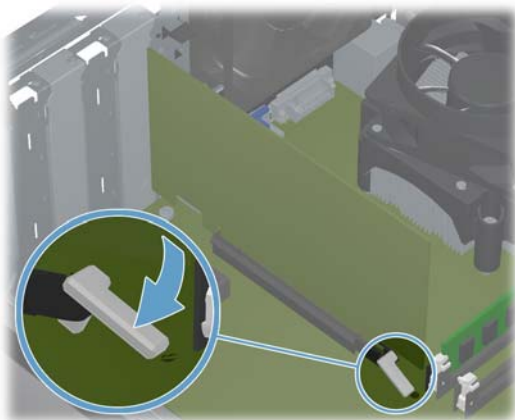

Carefully lift the card out of the slot.

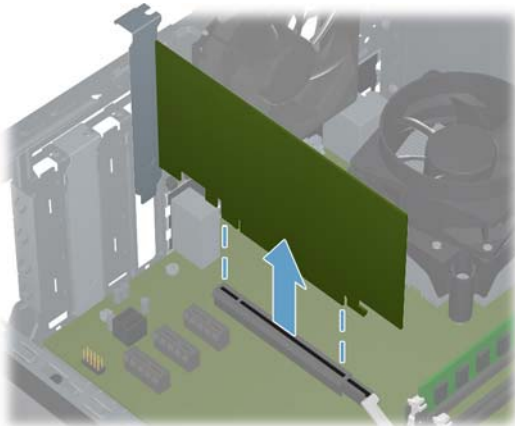

13. If the add-in card is in one of the smaller slots (TV tuner card), gently lift the card out to remove it. If there are connectors attached to the card, remove them.

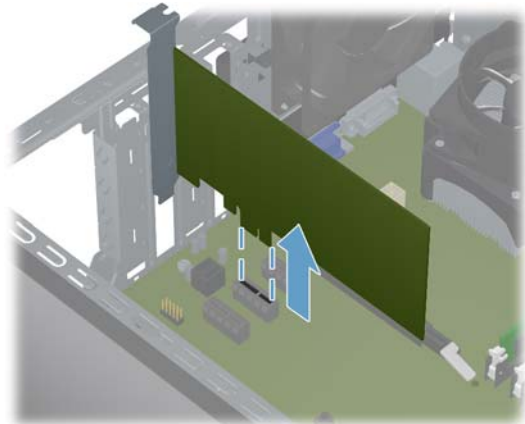

14. If there are additional add-in cards to be removed, repeat step 13 for each card.

Installing a new add-in card

 **NOTE:** The replacement part may look different than the original part because of manufacturer or model differences; however, the replacement part meets or exceeds the specifications of the original part.

1. Locate where the card will be seated inside the computer.

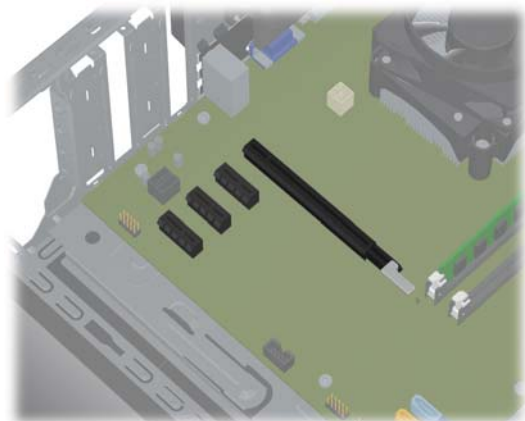

- 2.** Insert the add-in card into the slot on the motherboard, making sure it is firmly seated in place.

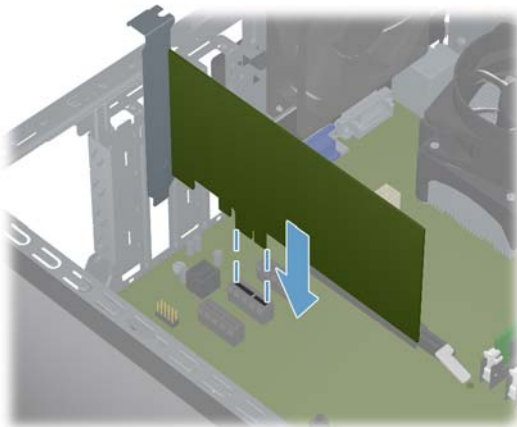
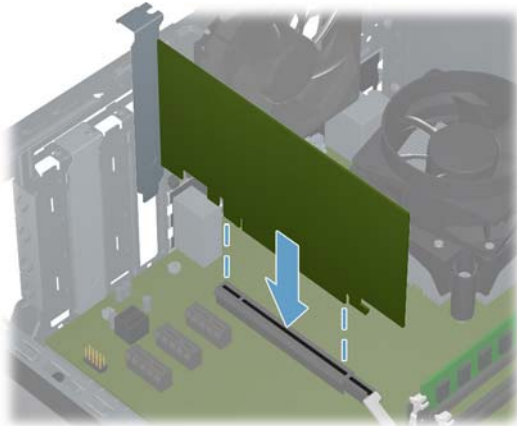

- 3.** Reconnect the auxiliary power cable to the motherboard.

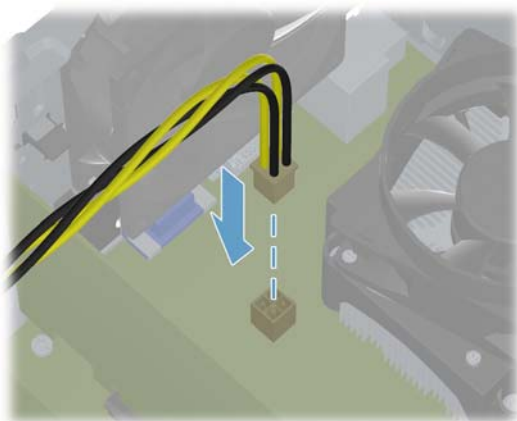

- 4.** To secure the add-in card in place, install the bracket on the back of the computer.

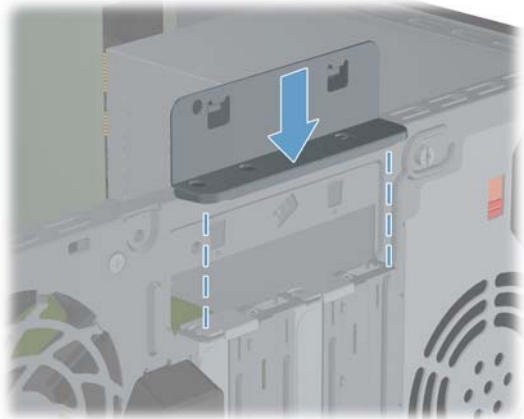

- 5.** Replace the screw that secures the bracket to the computer.

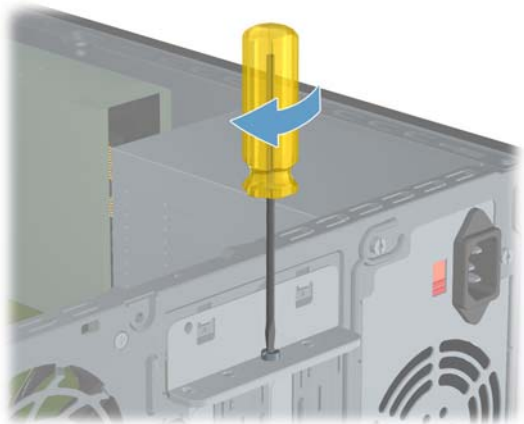

- 6.** Place the computer in an upright position.

7. Install the side panel on the side of the computer, and then slide it toward the front of the computer.



NOTE: Make sure the panel is flush with the computer. Failure to do so might cause the panel to bend slightly outward and not close securely.

8. Tighten the screw, securing the side panel to the back of the computer.

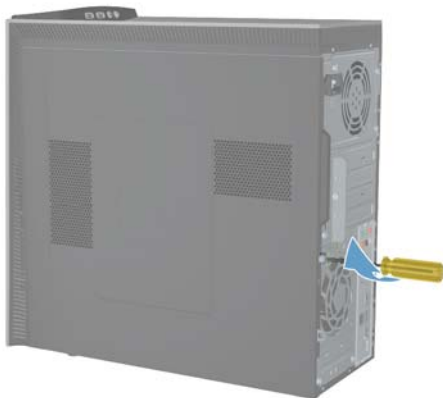

9. Plug the power cord and any additional cables into the back of the computer.



10. Press the power button to turn on the computer.



TASK COMPLETED

Printed in:

Removing and Replacing a Power Supply

Computer features may vary by model.



15 - 20 minutes

Before you begin

Observe the following requirements before removing and replacing the power supply.

- ⚠ WARNING!** Never open the cover with the power applied. You might damage your computer or be injured by the spinning the fan blades.
- ⚠ WARNING!** Avoid touching sharp edges inside the computer.
- ⚠ WARNING!** Keep your hands away from the moving fan.
- ⚠ WARNING!** Keep fingers and tools clear of the fan when the power is applied.
- ⚠ CAUTION:** Static electricity can damage the electronic components inside the computer. Discharge static electricity by touching the metal cage of the computer before touching any internal parts or electronic components.

Tools Needed

- Flathead/T15 Torx screwdriver

Small screws are easily lost. Remove screws over a surface that enables you to retrieve them if they fall.

Removing a power supply

1. Remove any media or storage devices such as CDs, DVDs, and USB.
2. Close all programs, and then shut down your operating system.

3. Unplug the computer by disconnecting the power cord and all attached cables from the back of the computer.



4. Using a flathead or Torx screwdriver, loosen the screw on the back panel that secures the panel to the computer.



5. Slide the side panel toward the back of the computer.



6. Pull the side panel away from the computer.



7. Lay the computer on a flat surface.



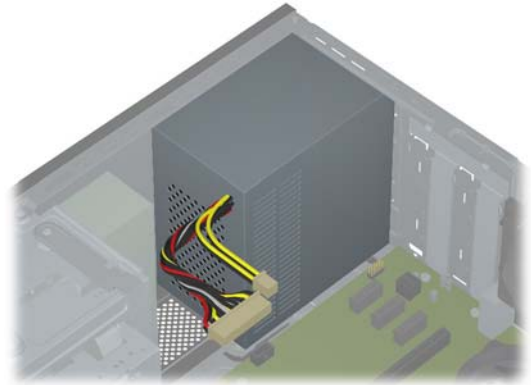

8. Locate the power supply in the computer.

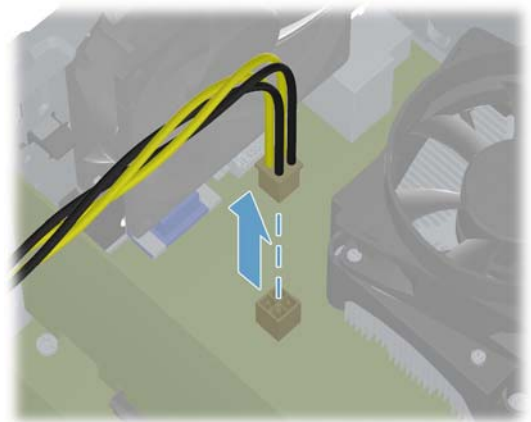

 **NOTE:** Before removing the power supply carefully note its orientation in the computer. The replacement power supply will need to be placed in the same position.

9. Press the latch on the power supply connector to disconnect it from the motherboard. This connector is located between the processor and the chassis fan.



 **NOTE:** The cables inside the unit might be held together by a tie-wrap. If so, carefully cut the tie-wrap so the power supply can be removed at the end of the procedure.

- 10.** Press the latch on the power supply connector close to the hard disk drive to disconnect it from the motherboard.

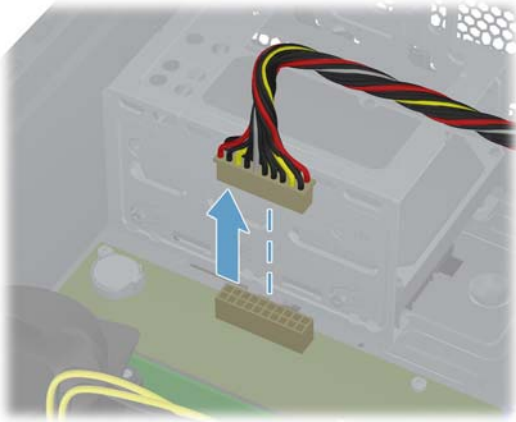

- 12.** Disconnect the power cable from the hard disk drive. The cable may have a latch that is pressed to remove the cable.

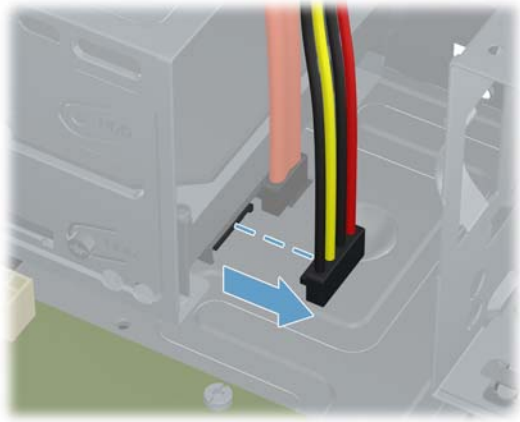

- 11.** Disconnect the power cable from the CD/DVD drive. The cable may have a latch that is pressed to remove the cable.

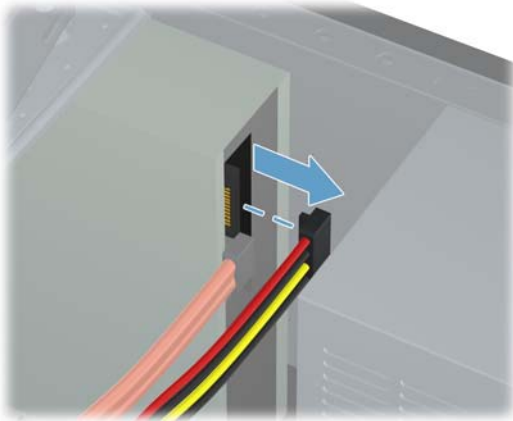

- 13.** Remove the four screws that secure the power supply, from the back of the computer.

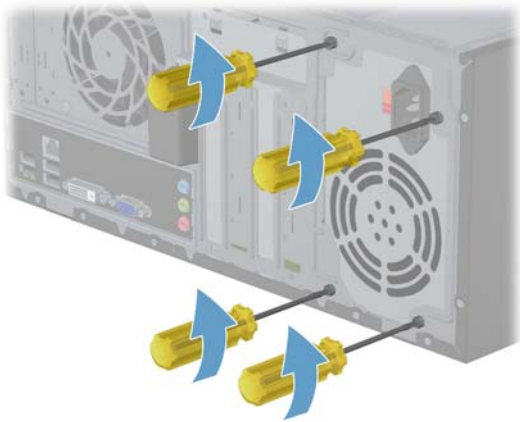

- 14.** With a screwdriver, push down on the latch to unlock the power supply.

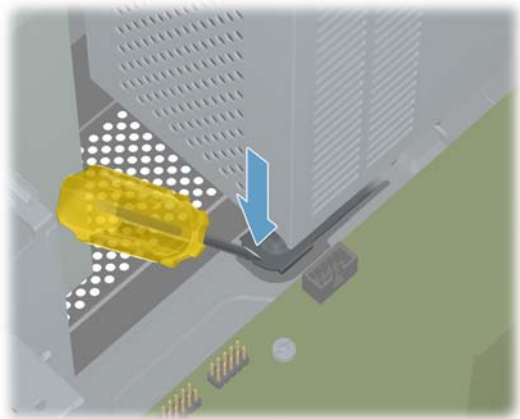

15. Move the power supply toward the front of the computer, and then tilt it out of the computer.

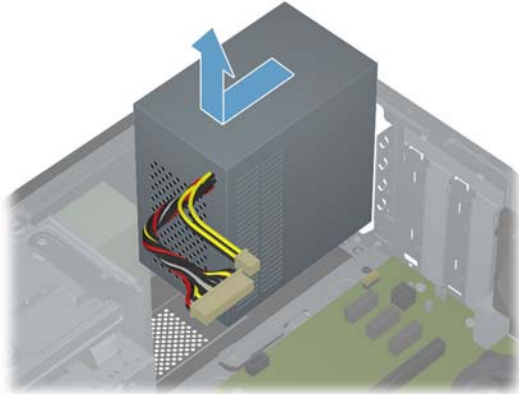

Replacing a power supply

 **NOTE:** The replacement part may look different than the original part because of manufacturer or model differences; however, the replacement part meets or exceeds the specifications of the original part.

 **NOTE:** Always replace the entire power supply. Never attempt to work within the power supply unit.

1. Make sure the replacement power supply is oriented the same way as the original power supply.
2. Carefully tilt the power supply into the computer, and then slide it toward the back of the computer until it locks into place.

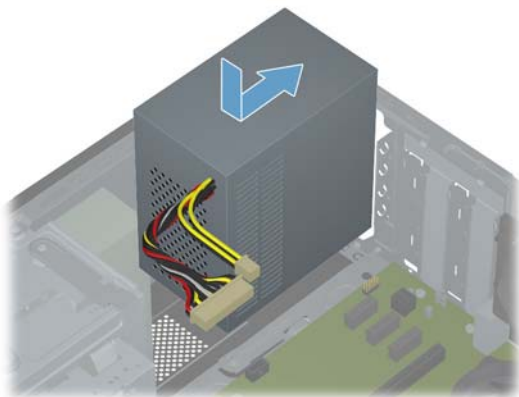

3. Install the four screws that secure the power supply to the computer.

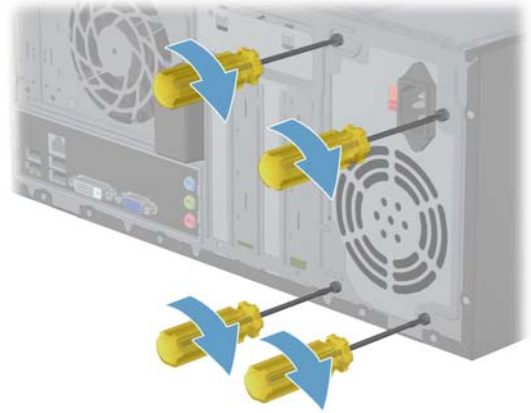

4. Insert the power supply connector into the motherboard until it locks into place. Make sure the cable does not interfere with the processor fan.

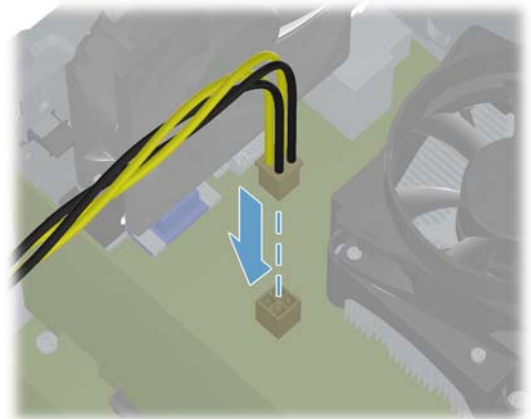

5. Reattach the power supply connector, that is close to the hard disk drive, into the motherboard. Make sure the cable does not interfere with the processor fan.

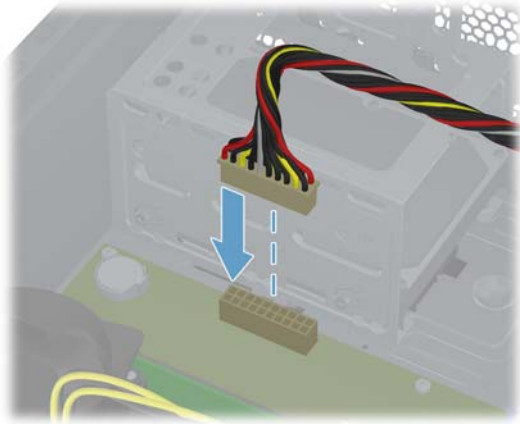

6. Reattach the power cable to the CD/DVD drive. Make sure the cable does not interfere with the processor fan.

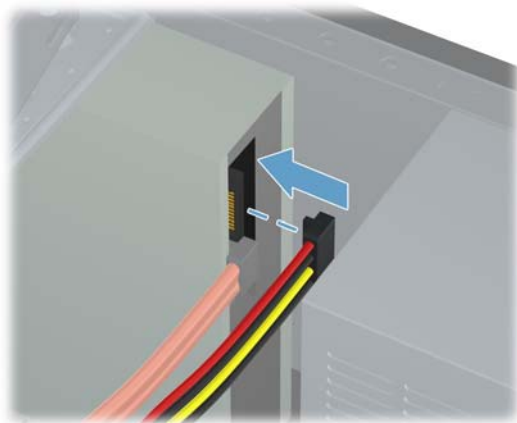

7. Reattach the power cable to the hard disk drive. Make sure the cable does not interfere with the processor fan.

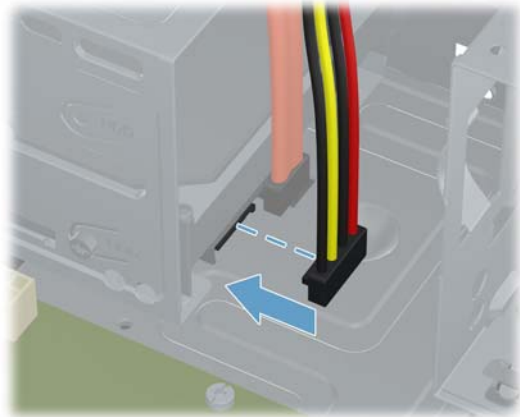

8. Place the computer in an upright position.
9. Install the side panel on the side of the computer, and then slide it toward the front of the computer.



NOTE: Make sure the panel is flush with the computer. Failure to do so might cause the panel to bend slightly outward and not close securely.

- 10.** Tighten the screw, securing the side panel to the back of the computer.



TASK COMPLETED

Printed in:

- 11.** Plug the power cord and any additional cables into the back of the computer.



- 12.** Press the power button to turn on the computer.

