



HP ENVY 15 Notebook PC and HP ENVY TouchSmart 15 Notebook PC

Maintenance and Service Guide

© Copyright 2013 Hewlett-Packard
Development Company, L.P.

AMD, the AMD Arrow logo, and combinations thereof, are trademarks of Advanced Micro Devices, Inc. Bluetooth is a trademark owned by its proprietor and used by Hewlett-Packard Company under license. Intel and Core are trademarks of Intel Corporation in the U.S. and other countries. Microsoft and Windows are U.S. registered trademarks of Microsoft Corporation. SD Logo is a trademark of its proprietor.

The information contained herein is subject to change without notice. The only warranties for HP products and services are set forth in the express warranty statements accompanying such products and services. Nothing herein should be construed as constituting an additional warranty. HP shall not be liable for technical or editorial errors or omissions contained herein.

First Edition: April 2013

Document Part Number: 716681-001

Safety warning notice

⚠ WARNING! To reduce the possibility of heat-related injuries or of overheating the device, do not place the device directly on your lap or obstruct the device air vents. Use the device only on a hard, flat surface. Do not allow another hard surface, such as an adjoining optional printer, or a soft surface, such as pillows or rugs or clothing, to block airflow. Also, do not allow the AC adapter to contact the skin or a soft surface, such as pillows or rugs or clothing, during operation. The device and the AC adapter comply with the user-accessible surface temperature limits defined by the International Standard for Safety of Information Technology Equipment (IEC 60950).

Table of contents

1 Product description	1
2 External component identification	9
Finding your hardware and software information	9
Locating hardware	9
Locating software	9
Display	10
Buttons and speakers	11
Keys	12
Lights	13
TouchPad	14
Left side	15
Right side	17
Bottom	18
3 Illustrated parts catalog	19
Service tag	19
Computer major components	21
Display assembly subcomponents	27
Mass storage devices	28
Miscellaneous parts	29
Sequential part number listing	30
4 Removal and replacement procedures preliminary requirements	37
Tools required	37
Service considerations	37
Plastic parts	37
Cables and connectors	38
Drive handling	38
Grounding guidelines	39
Electrostatic discharge damage	39

Packaging and transporting guidelines	40
Workstation guidelines	40
5 Removal and replacement procedures for Customer Self-Repair parts	42
Component replacement procedures	42
Battery	43
Solid-state drive	44
WLAN module	45
Hard drive	47
Memory module	49
6 Removal and replacement procedures for Authorized Service Provider parts	52
Component replacement procedures	52
RTC battery	52
Base enclosure	55
Display assembly	57
Fan	65
System board	66
Heat sink	72
Processor	77
Connector board	80
Power connector cable	82
Subwoofer	83
Rear speakers	85
Fingerprint reader board	87
Front speakers	88
TouchPad assembly	90
Power button board	93
Keyboard	95
7 Using Setup Utility (BIOS) and System Diagnostics	99
Starting Setup Utility (BIOS)	99
Updating the BIOS	99
Determining the BIOS version	99
Downloading a BIOS update	100
Using System Diagnostics	101
8 Specifications	102
Computer specifications	102
15.6-inch display specifications	103

Hard drive specifications	104
9 Backing up, restoring, and recovering	105
Creating recovery media and backups	106
Creating HP Recovery media	107
Restore and recovery	108
Using Windows Refresh for quick and easy recovery	109
Remove everything and reinstall Windows	109
Recovering using HP Recovery Manager	110
What you need to know	110
Using the HP Recovery partition to recover a minimized image (select models only)	111
Using HP Recovery media to recover	111
Changing the computer boot order	111
Removing the HP Recovery partition	112
10 Power cord set requirements	113
Requirements for all countries	113
Requirements for specific countries and regions	114
11 Recycling	115
Index	116

1 Product description

Category	Description	Computer models equipped with an AMD processor	Computer models equipped with an Intel processor
Product Name	HP ENVY 15 Notebook PC	√	√
	HP ENVY TouchSmart 15 Notebook PC		
Processors	<ul style="list-style-type: none">• AMD® A10-5750M 2.50-GHz processor (turbo up to 3.50-GHz; 1600-MHz FSB, 4.0-MB L2 cache, DDR3, quad core, 35 W)• AMD A8-5550M 2.10-GHz processor (turbo up to 3.10-GHz; 1600-MHz FSB, 4.0-MB L2 cache, DDR3, quad core, 35 W)• AMD A6-5350M 2.90-GHz processor (turbo up to 3.50-GHz; 1600-MHz FSB, 1.0-MB L2 cache, DDR3, dual core, 35 W)• AMD A4-5150M 2.70-GHz processor (turbo up to 3.30-GHz; 1600-MHz FSB, 1.0-MB L2 cache, DDR3, dual core, 35 W)	√	

Category	Description	Computer models equipped with an AMD processor	Computer models equipped with an Intel processor
Processors <i>(continued)</i>	<ul style="list-style-type: none"> <li data-bbox="576 275 986 401">• Intel® Quad Core® i7-4900MQ 2.80-GHz processor (SC turbo up to 3.80-GHz; 1600-MHz FSB, 8.0-MB L3 cache, 47 W) <li data-bbox="576 422 986 548">• Intel Quad Core i7-4800MQ 2.70-GHz processor (SC turbo up to 3.70-GHz; 1600-MHz FSB, 6.0-MB L3 cache, 47 W) <li data-bbox="576 569 986 695">• Intel Quad Core i7-4702MQ 2.20-GHz processor (SC turbo up to 3.20-GHz; 1600-MHz FSB, 6.0-MB L3 cache, 37 W) <li data-bbox="576 716 986 842">• Intel Quad Core i7-4700MQ 2.40-GHz processor (SC turbo up to 3.40-GHz; 1600-MHz FSB, 6.0-MB L3 cache, 47 W) <li data-bbox="576 863 986 989">• Intel Dual Core i5-3380M 2.90-GHz processor (SC turbo up to 3.60-GHz; 1600-MHz FSB; 3.0-MB L3 cache, 35 W) <li data-bbox="576 1010 986 1136">• Intel Dual Core i5-3230M 2.60-GHz processor (SC turbo up to 3.20-GHz; 1600-MHz FSB, 3.0-MB L3 cache, 35 W) <li data-bbox="576 1157 986 1283">• Intel Dual Core i3-3130M 2.60-GHz processor (1600-MHz FSB, 3.0-MB L3 cache, 35 W) <li data-bbox="576 1304 986 1339">• Intel Dual Core i5-3120M 2.40-GHz processor (1600-MHz FSB, 3.0-MB L3 cache, 35 W) 		√
Chipset	AMD A76M fusion controller hub	√	
	Intel HM87 Express Chipset		√
	Intel HM77 Express Chipset		

Category	Description	Computer models equipped with an AMD processor	Computer models equipped with an Intel processor
Graphics	<p data-bbox="603 285 799 312">Internal graphics:</p> <ul data-bbox="603 338 991 787" style="list-style-type: none"> <li data-bbox="603 338 991 451">• AMD Radeon™ HD 8650G graphics (only on computer models equipped with an AMD A10 processor) <li data-bbox="603 476 991 569">• AMD Radeon HD 8550G graphics (only on computer models equipped with an AMD A8 processor) <li data-bbox="603 594 991 686">• AMD Radeon HD 8450G graphics (only on computer models equipped with an AMD A6 processor) <li data-bbox="603 711 991 787">• AMD Radeon HD 8350G graphics (only on computer models equipped with an AMD A4 processor) <p data-bbox="603 812 836 840">Switchable graphics:</p> <ul data-bbox="603 865 991 1518" style="list-style-type: none"> <li data-bbox="603 865 991 1010">• AMD Radeon HD 8750M with 2048-GB of dedicated video memory (128-MB×16 DDR3 900-MHz×8PCs, DDR3 1-GHz downgrade to DDR3 900MHz) <li data-bbox="603 1035 991 1180">• AMD Radeon HD 8750M + HD 8650G dual graphics with AMD discrete graphics (only on computer models equipped with an AMD A10 processor) <li data-bbox="603 1205 991 1350">• AMD Radeon HD 8750M + HD 8550G dual graphics with AMD discrete graphics (only on computer models equipped with an AMD A8 processor) <li data-bbox="603 1375 991 1518">• AMD Radeon HD 8750M + HD 8450G dual graphics with AMD discrete graphics (only on computer models equipped with an AMD A6 processor) <p data-bbox="603 1543 991 1570">Support for HD decode, DX11, and HDMI</p> <p data-bbox="603 1596 767 1623">Support for PX5.5</p>	√	

Category	Description	Computer models equipped with an AMD processor	Computer models equipped with an Intel processor
Graphics <i>(continued)</i>	<p>Internal graphics:</p> <ul style="list-style-type: none"> • Intel HD Graphics 4600 on computer models equipped with a Quad Core processor • Intel HD Graphics 4000 on computer models equipped with a Dual Core processor <p>Switchable Discrete Graphics:</p> <ul style="list-style-type: none"> • nVidia N14P-GT GeForce 750M with 2048-GB of dedicated video memory (128-MB×16 DDR3 1-GHz×8PCs) • nVidia N14P-GV2 GeForce 740M with 2048-GB of dedicated video memory (128-MB×16 DDR3 1-GHz×8PCs) <p>Support for HD decode, DX11, and HDMI</p> <p>Support for GPU performance scaling</p> <p>Support for Optimus</p>		√
Panel	<p>Support for the following display assemblies:</p> <ul style="list-style-type: none"> • 15.6-in, full high-definition (FHD), white light-emitting diode (WLED), BrightView (1920×1080), slim (3.2-mm), UWVA (IPS), color gamut 72%, typical brightness 300 nits, 16:9 aspect ratio • 15.6-in, full high-definition (FHD), white light-emitting diode (WLED), BrightView (1920×1080), slim (3.2-mm), SVA, color gamut 60%, typical brightness 300 nits, 16:9 aspect ratio • 15.6-in, high-definition (HD), white light-emitting diode (WLED), BrightView (1366×768), flat (3.8-mm), SVA, color gamut 45%, typical brightness 200 nits, 16:9 aspect ratio <p>Support for low-voltage differential signalling LVDS, co-layout with eDP1.3+PSR)</p> <p>Touchscreen and MultiTouch enabled</p>	√	√

Category	Description	Computer models equipped with an AMD processor	Computer models equipped with an Intel processor
Memory	<p>Two customer-accessible/upgradable memory module slots</p> <p>Support for DDR3L (1600-MHz) dual channel</p> <p>Support for 16834-MB of system RAM in the following configurations:</p> <ul style="list-style-type: none"> • 16834-MB (8192-MB×2) • 12288-MB (8192-MB+4096-MB) • 8192-MB (8192-MB×1, 4096-MB×2) • 6144-MB (4096-MB+2048-MB) • 4096-MB (4096-MB×1, 2048-MB×2) 	√	√
Hard drive	<p>Support for 6.35-cm (2.5-in) hard drives in 7.0-mm (.28-in) and 9.5-mm (.37-in) thickness</p> <p>Support for Serial ATA // Support for mSATA</p> <p>Support Intel Smart Response Technology</p> <p>Support for Accelerometer hard drive protection</p> <p>Support for the following hard drives:</p> <ul style="list-style-type: none"> • 1-TB, 5400-rpm, 9.5-mm • 750-GB, 5400-rpm, 9.5-mm • 500-GB, 5400-rpm, 9.5- and 7.0-mm 	√	√
Solid-state drive	<p>Support for 24-GB mSATA solid-state drive (not available on computer models equipped with 16834-MB or 12288-MB system memory)</p>		√

Category	Description	Computer models equipped with an AMD processor	Computer models equipped with an Intel processor
Audio and video	<p>Quad speakers</p> <p>Subwoofer</p> <p>Dual array digital microphones with appropriate beam-forming, echo-cancellation, noise-suppression software</p> <p>HD Audio</p> <p>Beats Audio</p> <p>Integrated HP TrueVision HD webcam (fixed [no tilt], activity LED, 1280×720 by 30 frames per second)</p>	√	√
Ethernet	Integrated 10/100/1000 network interface card (NIC)	√	√
Wireless	<p>Integrated wireless local area network (WLAN) options by way of wireless module</p> <p>Two WLAN antennas built into display assembly</p> <p>Support for the following WLAN formats:</p> <ul style="list-style-type: none"> • Atheros AR9485 802.11b/g/n WiFi Adapter • Mediatek MT7630E 802.11bgn Wi-Fi Adapter and Mediatek Bluetooth 4.0 Adapter • Ralink RT3290LE 802.11b/g/n 1×1 WiFi and Bluetooth 4.0 Combo Adapter • Realtek RTL8188EE 802.11bgn Wi-Fi Adapter 	√	√
	<ul style="list-style-type: none"> • Intel Centrino Wireless-N 2230 Combo Adapter 		√
External media cards	HP 2-in-1 multifunction Digital Media Reader Slot with push-push technology (uses the Realtek RTS5239-GR card reader controller). Reads data from and writes data to digital memory cards such as Secure Digital (SD).	√	√

Category	Description	Computer models equipped with an AMD processor	Computer models equipped with an Intel processor
Ports	<ul style="list-style-type: none"> AC adapter, HP Smart Audio-in (mono microphone)/audio-out (stereo headphone) combo jack HDMI v1.4 supporting up to 1920×1080 @ 60Hz RJ-45 (Ethernet) USB: four USB 3.0 ports, one USB 2.0 port 	√	√
Keyboard/pointing devices	<p>Full-size, backlit, island-style keyboard with numeric keypad and DuraCoat, Clickpad with image sensor</p> <p>Gesture support: MultiTouch gestures enabled, two-finger scrolling, and pinch-zoom as default</p> <p>Taps enabled by default</p> <p>Support for Windows 8 modern trackpad</p>	√	√
Power requirements	<p>Support for the following AC adapters:</p> <ul style="list-style-type: none"> 90-W HP Smart AC adapter (PFC, 4.5-mm) 65-W HP Smart AC adapter (non-PFC, 4.5-mm) 	√	√
	<ul style="list-style-type: none"> 120-W HP Slim AC adapter (PFC, EM, 4.5-mm) 90-W HP Smart AC adapter (PFC EM, 4.5-mm) 65-W HP Smart AC adapter (non-PFC, EM, 4.5-mm) 		√
Power requirements <i>(continued)</i>	<p>Support for the following batteries</p> <ul style="list-style-type: none"> 6-cell, 62-Wh, 2.80-Ah, Li-ion battery 6-cell, 47-Wh, 2.20-Ah, Li-ion battery 	√	√

Category	Description	Computer models equipped with an AMD processor	Computer models equipped with an Intel processor
Security	Support for the following: <ul style="list-style-type: none"> • Security cable lock • Fingerprint reader with Digital Persona software • HP SimplePass (only available on computer models equipped with a fingerprint ready) 	√	
	Support for the following: <ul style="list-style-type: none"> • Security cable lock • Fingerprint reader with Digital Persona software • HP SimplePass (only available on computer models equipped with a fingerprint ready) • Intel AT-p Ready 		√
Operating system	Preinstalled: Windows 8	√	√
Serviceability	End user replaceable parts: <ul style="list-style-type: none"> • AC adapter • Battery (system) • Hard drive • Memory modules (expansion and primary) • WLAN module 	√	√
	<ul style="list-style-type: none"> • Solid-state drive 		√

2 External component identification

Finding your hardware and software information

Locating hardware

To find out what hardware is installed on your computer:

1. From the Start screen, type **c**, and then select **Control Panel**.
2. Select **System and Security**, and then in the **System** area, select **Device Manager**.

A list reveals all the devices installed in your computer.

Locating software

- ▲ To find out what software is installed on your computer, from the Start screen, right-click using the mouse or swipe from the top of the TouchPad to reveal the apps and then select the **All apps** icon.

Display

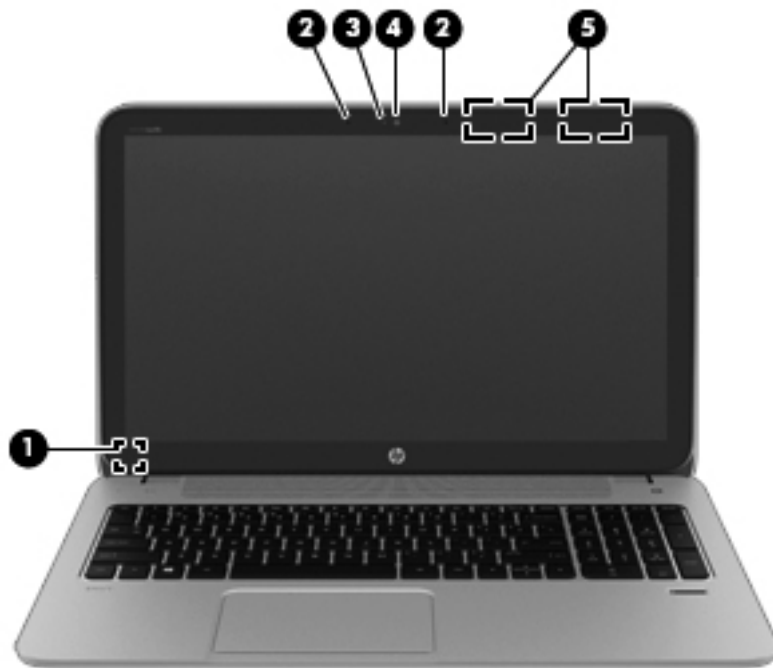

Item	Component	Description
(1)	Internal display switch	Turns off the display and initiates Sleep if the display is closed while the power is on. NOTE: The internal display switch is not visible from the outside of the computer.
(2)	Internal microphones (2)	Record sound.
(3)	Webcam light	On: The webcam is in use.
(4)	HP TrueVision HD Webcam	Records video and takes still photographs. Swipe from the right edge of the TouchPad or touch screen (select models only) to display the charms, tap Search , and then tap the search box. Type <i>c</i> , and then select CyberLink YouCam from the list of applications. – or – From the Start screen, type <i>c</i> , and then select CyberLink YouCam from the list of applications.
(5)	WLAN antennas (2)*	Send and receive wireless signals to communicate with WLANs.

*The antennas are not visible from the outside of the computer. For optimal transmission, keep the areas immediately around the antennas free from obstructions. For wireless regulatory notices, see the section of the *Regulatory, Safety, and Environmental Notices* that applies to your country or region. To access this guide, from the Start screen, type *support*, select the **HP Support Assistant app**, select **My computer**, and then select **User guides**.

Buttons and speakers

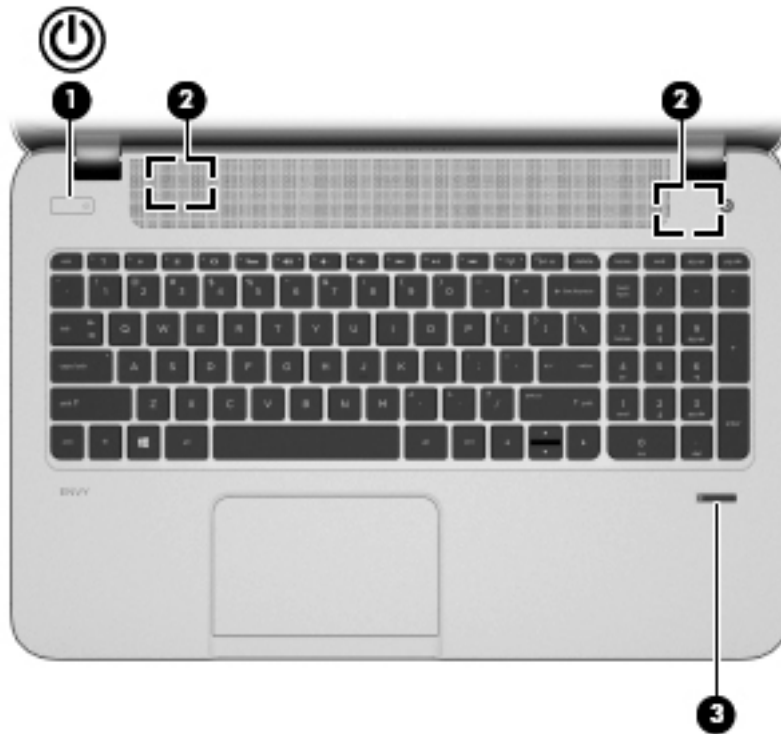

Item	Component	Description
(1)	Power button	<ul style="list-style-type: none">• When the computer is off, press the button to turn on the computer.• When the computer is on, press the button briefly to initiate Sleep.• When the computer is in the Sleep state, press the button briefly to exit Sleep. <p>CAUTION: Pressing and holding down the power button will result in the loss of unsaved information.</p> <p>If the computer has stopped responding and Microsoft Windows shutdown procedures are ineffective, press and hold the power button down for at least 5 seconds to turn off the computer.</p> <p>Swipe from the right edge of the TouchPad or touch screen (select models only) to display the charms, tap Search, and then tap the search box. In the search box, type <code>power</code>, select Settings, and then select Power options.</p> <p>– or –</p> <p>To learn more about your power settings, from Start screen, type <code>p</code>. In the search box, type <code>power</code>, select Settings, and then select Power options.</p>

Item	Component	Description
(2)	Speakers (2)	Produce sound.
(3)	Fingerprint reader (select models only)	Allows a fingerprint logon to Windows, instead of a password logon.

Keys

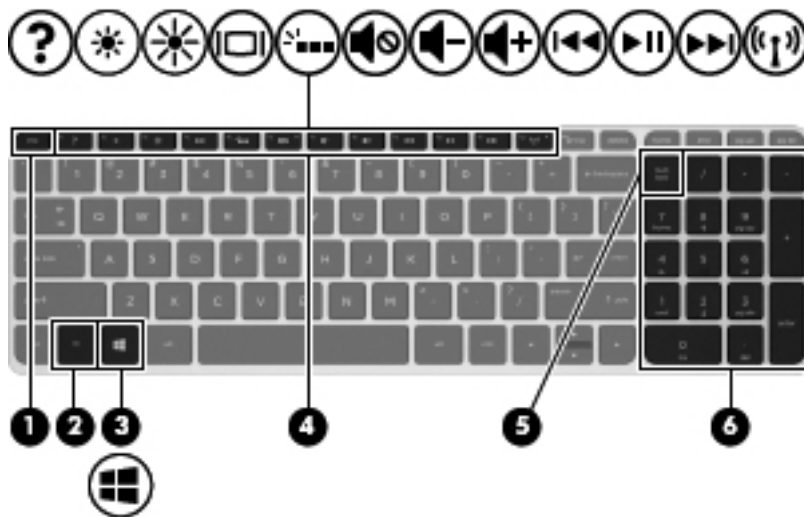

Item	Component	Description
(1)	esc key	Reveals system information when pressed in combination with the fn key.
(2)	fn key	Executes frequently used system functions when pressed in combination with the b key, the spacebar , or the esc key.
(3)	Windows key	Returns you to the Start screen from an open app or the Windows desktop. NOTE: Pressing the Windows logo key again will return you to the previous screen.
(4)	Action keys	Execute frequently used system functions. NOTE: On select models, the f5 action key turns the radiance backlight keyboard feature off or on.
(5)	num lk key	Alternates between the navigational and numeric functions on the integrated numeric keypad.
(6)	Integrated numeric keypad	When num lk has been enabled, it can be used like an external numeric keypad.

Lights

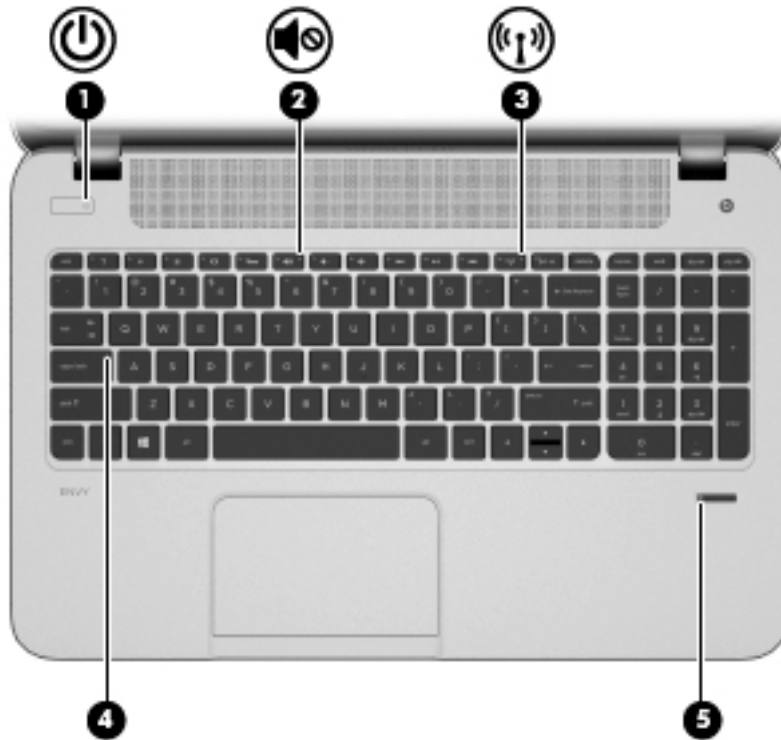

Item	Component	Description
(1)	Power light	<ul style="list-style-type: none"> White: The computer is on. Blinking white: The computer is in the Sleep state, which is an energy-saving mode. The computer shuts off power to the display and other unneeded components. Off: The computer is off or in Hibernation. Hibernation is an energy-saving mode that uses the least amount of power. <p>NOTE: For select models, the Intel Rapid Start Technology feature is enabled at the factory. Rapid Start Technology allows your computer to resume quickly from inactivity.</p>
(2)	Mute light	<ul style="list-style-type: none"> Amber: Computer sound is off. Off: Computer sound is on.
(3)	Wireless light	<p>On: An integrated wireless device, such as a WLAN device and/or a Bluetooth device, is on.</p> <p>NOTE: On some models, the wireless light is amber when all wireless devices are off.</p>

Item	Component	Description
(4)	Caps lock light	On: Caps lock is on, which switches the keys to all capital letters.
(5)	Fingerprint reader light	<ul style="list-style-type: none"> White: The fingerprint authentication was successful. Amber: The fingerprint authentication failed.

TouchPad

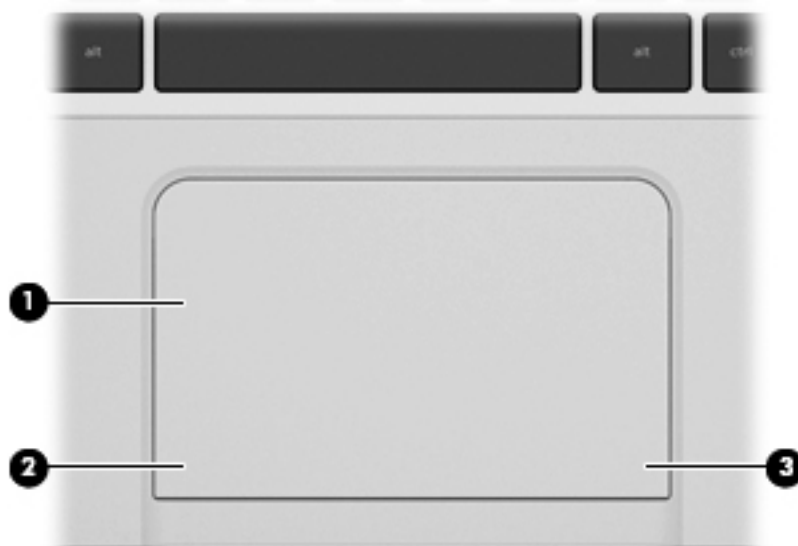

Item	Component	Description
(1)	TouchPad zone	<p>Moves the on-screen pointer and selects or activates items on the screen.</p> <p>NOTE: The TouchPad also supports edge-swipe gestures.</p>
(2)	Left TouchPad button	Functions like the left button on an external mouse.
(3)	Right TouchPad button	Functions like the right button on an external mouse.

Left side

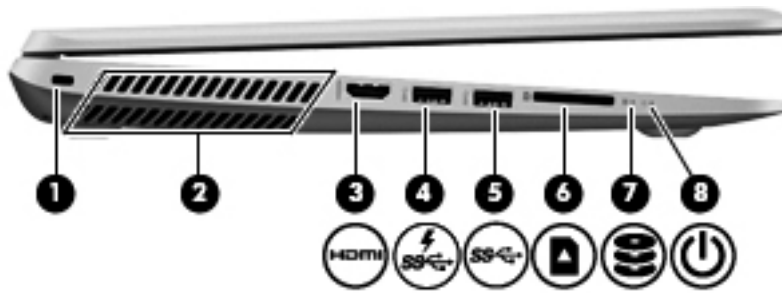

Item	Component	Description
(1)	Security cable slot	Attaches an optional security cable to the computer. NOTE: The security cable is designed to act as a deterrent, but it may not prevent the computer from being mishandled or stolen.
(2)	Vents (2)	Enables airflow to cool internal components. NOTE: The computer fan starts up automatically to cool internal components and prevent overheating. It is normal for the internal fan to cycle on and off during routine operation.
(3)	HDMI port	Connects an optional video or audio device, such as a high-definition television, any compatible digital or audio component, or a high-speed HDMI device.
(4)	USB 3.0 charging port	Connects an optional USB device. The USB 3.0 charging port can also charge select models of cell phones and MP3 players, even when the computer is off. NOTE: A USB charging port (also referred to as a USB powered port) allows you to charge connected USB devices. Standard USB ports will not charge all USB devices or will charge using a low current. Some USB devices require power and require you to use a powered port.
(5)	USB 3.0 port	Connects optional USB 3.0 devices and provide enhanced USB power performance.
(6)	Digital Media Card Reader	Reads data from and writes data to digital memory cards such as Secure Digital (SD).

Item	Component	Description
(7)	Hard drive light	<ul style="list-style-type: none"> Blinking white: The hard drive is being accessed. Amber: HP 3D DriveGuard has temporarily parked the hard drive.
(8)	Power light	<ul style="list-style-type: none"> White: The computer is on. Blinking white: The computer is in the Sleep state, which is an energy-saving mode. The computer shuts off power to the display and other unneeded components. Off: The computer is off or in Hibernation. Hibernation is an energy-saving mode that uses the least amount of power. <p>NOTE: For select models, the Intel Rapid Start Technology feature is enabled at the factory. Rapid Start Technology allows your computer to resume quickly from inactivity.</p>

Right side

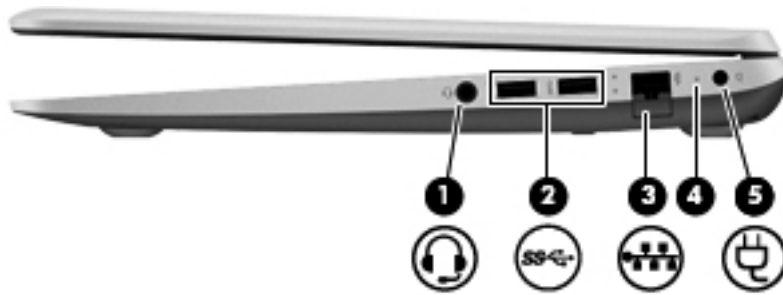

Item	Component	Description
(1)	Audio-out (headphone) jack/Audio-in (microphone) jack	<p>Connects optional powered stereo speakers, headphones, earbuds, a headset, or a television audio cable. Also connects an optional headset microphone. This jack does not support optional microphone-only devices.</p> <p>WARNING! To reduce the risk of personal injury, adjust the volume before putting on headphones, earbuds, or a headset. For additional safety information, refer to the Regulatory, Safety, and Environmental Notices. To access this guide, from the Start screen, type <code>support</code>, select the HP Support Assistant app, select My computer, and then select User guides.</p> <p>NOTE: When a device is connected to the jack, the computer speakers are disabled.</p> <p>NOTE: Be sure that the device cable has a 4-conductor connector that supports both audio-out (headphone) and audio-in (microphone).</p>
(2)	USB 3.0 ports (2)	Connect optional USB 3.0 devices and provide enhanced USB power performance.
(3)	RJ-45 (network) jack	Connects a network cable.
(4)	RJ-45 (network) jack status light	<ul style="list-style-type: none"> • White: The network is connected. • Amber: Activity is occurring on the network.
(5)	AC adapter light	<ul style="list-style-type: none"> • White: The AC adapter is connected and the battery is charged. • Amber: The AC adapter is connected and the battery is charging. • Off: The computer is using DC power.
(6)	Power connector	Connects an AC adapter.

Bottom

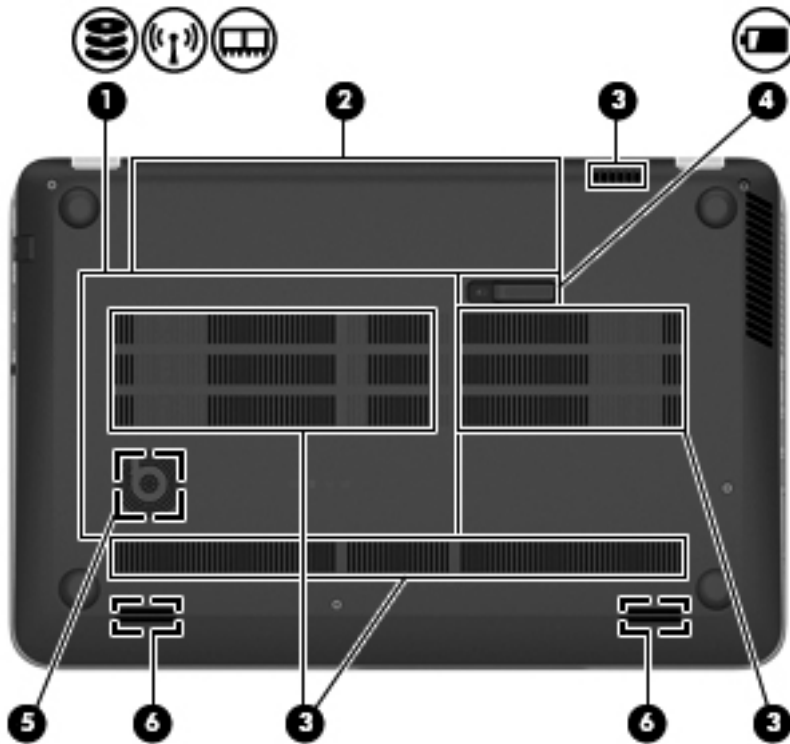

Item	Component	Description
(1)	Service cover	Provides access to the hard drive bay, the WLAN module slot, and the memory module slots. CAUTION: To prevent an unresponsive system, replace the wireless module only with a wireless module authorized for use in the computer by the governmental agency that regulates wireless devices in your country or region. If you replace the module and then receive a warning message, remove the module to restore computer functionality, and then contact support through Help and Support. From the Start screen, type h, and then select Help and Support .
(2)	Battery bay	Holds the battery.
(3)	Vents (3)	Enables airflow to cool internal components. NOTE: The computer fan starts up automatically to cool internal components and prevent overheating. It is normal for the internal fan to cycle on and off during routine operation.
(4)	Battery release latch	Releases the battery from the battery bay.
(5)	HP Triple Bass Reflex Subwoofer	Provides superior bass sound.
(6)	Speakers (2)	Produce sound.

3 Illustrated parts catalog

Service tag

When ordering parts or requesting information, provide the computer serial number and model number provided on the service tag.

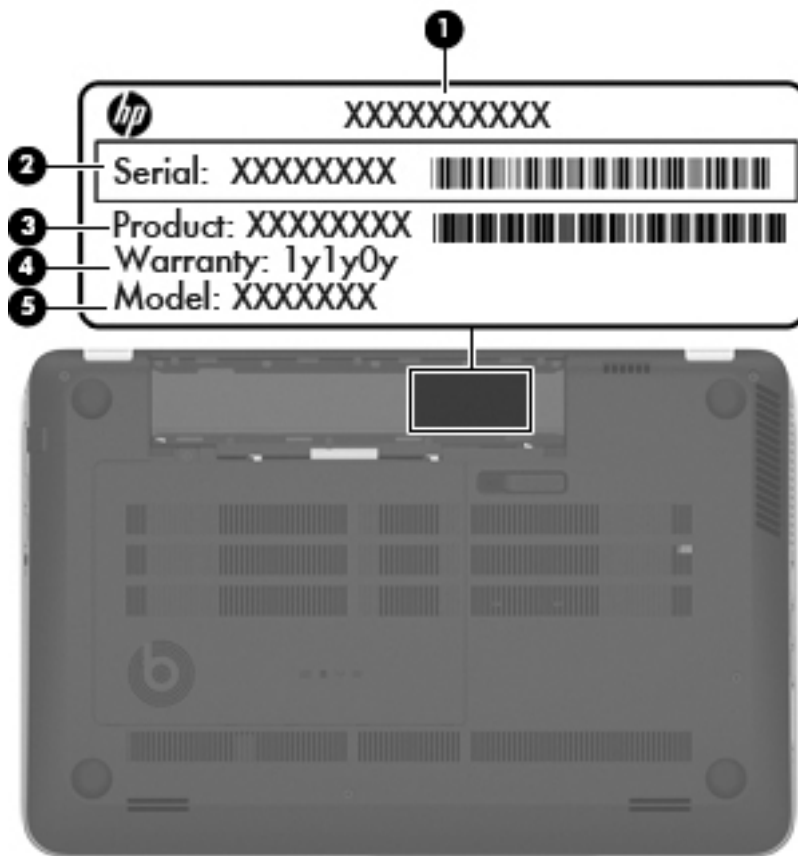

Item	Description	Function
(1)	Product name	This is the product name affixed to the front of the computer.
(2)	Serial number (s/n)	This is an alphanumeric identifier that is unique to each product.

Item	Description	Function
(3)	Part number/Product number (p/n)	This number provides specific information about the product's hardware components. The part number helps a service technician to determine what components and parts are needed.
(4)	Warranty period	This number describes the duration of the warranty period for the computer.
(5)	Model description	This is the alphanumeric identifier used to locate documents, drivers, and support for the computer.

Computer major components

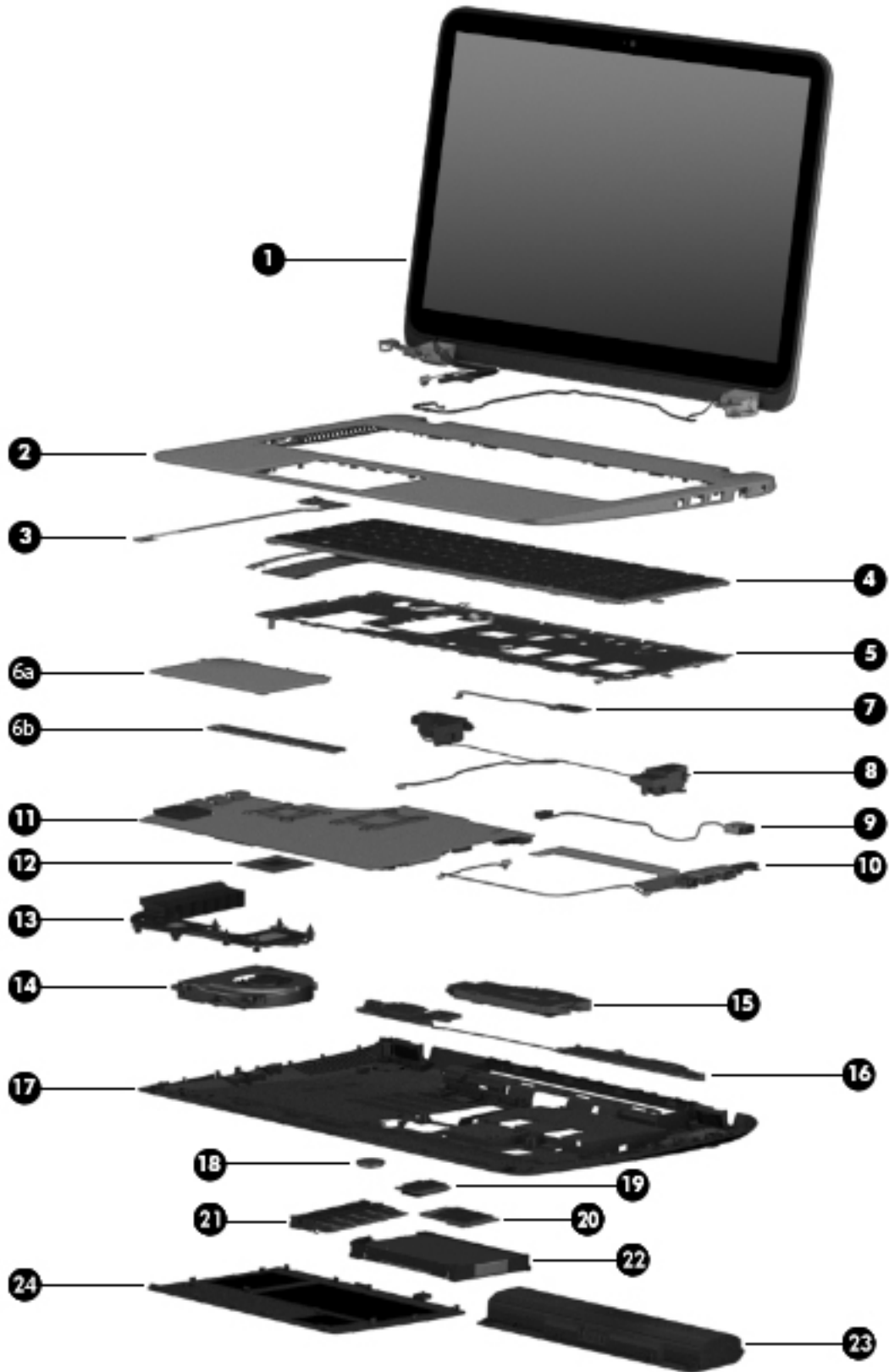

Item	Component	Spare part number
(1)	Display assembly (includes webcamera/microphone module and wireless antenna cables):	
	15.6-in, BrightView, FHD, LED, TouchScreen display assembly	720550-001
	15.6-in, BrightView, HD, LED, TouchScreen display assembly	720549-001
	15.6-in, BrightView, FHD, LED, non-TouchScreen display assembly	720552-001
	15.6-in, BrightView, HD, LED, non-TouchScreen display assembly	720551-001
	The subcomponents for the non-TouchScreen display assembly are also available as spare part kits. For more display assembly spare part information, see Display assembly subcomponents on page 27 .	
(2)	Top cover	720570-001
(3)	Power button board (includes cable)	720553-001
(4)	Keyboard (includes keyboard cable):	
	Keyboard with backlight (includes backlight cable):	
	For use only on computer models equipped with an Intel processor in Belgium	720244-A41
	For use on all computer models in Canada	720244-DB1
	For use only on computer models equipped with an Intel processor in the Czech Republic and Slovakia	720244-FL1
	For use only on computer models equipped with an Intel processor in Denmark, Finland, and Norway	720244-DH1
	For use only on computer models equipped with an Intel processor in France	720244-051
	For use only on computer models equipped with an Intel processor in Germany	720244-041
	For use only on computer models equipped with an Intel processor in Greece	720244-151
	For use only on computer models equipped with an Intel processor in Italy	720244-061
	For use on all computer models in Japan	720244-291
	For use on all computer models in Latin America	720244-161
	For use only on computer models equipped with an Intel processor in the Netherlands	720244-B31
	For use only on computer models equipped with an Intel processor in Portugal	720244-131
	For use only on computer models equipped with an Intel processor in Russia	720244-251
	For use only on computer models equipped with an Intel processor in Saudi Arabia	720244-171
	For use only on computer models equipped with an Intel processor in South Korea	720244-AD1
	For use only on computer models equipped with an Intel processor in Spain	720244-071
	For use only on computer models equipped with an Intel processor in Switzerland	720244-BG1
	For use only on computer models equipped with an Intel processor in Taiwan	720244-AB1
	For use only on computer models equipped with an Intel processor in Thailand	720244-281
	For use only on computer models equipped with an Intel processor in Turkey	720244-141

Item	Component	Spare part number
	For use only on computer models equipped with an Intel processor in the United Kingdom and Singapore	720244-031
	For use on all computer models in the United States	720244-001
	Keyboard with pointing stick for use on all computer models in the United States (includes pointing stick cable)	720242-001
(5)	Keyboard shield	720544-001
(6a)	TouchPad assembly (includes TouchPad bracket (6b) , TouchPad button board, TouchPad, and cables)	722972-001
(7)	Fingerprint reader board (includes bracket and cable)	720543-001
(8)	Rear speakers (include left and right rear speakers, 2 cables, and 4 isolators)	720561-001
(9)	Power connector cable:	
	For use on all computer models equipped with a graphics subsystem with UMA memory	720537-001
	For use only on computer models equipped with an Intel processor and a graphics subsystem with discrete memory	720538-001
(10)	Connector board (includes 2 cables):	
	For use only on computer models equipped with an AMD processor	720579-001
	For use only on computer models equipped with an Intel processor and a graphics subsystem with discrete memory	723372-001
	For use only on computer models equipped with an Intel processor and a graphics subsystem with UMA memory	720554-001
(11)	System board (includes replacement thermal material):	
	For use only on computer models equipped with an AMD processor, a graphics subsystem with discrete memory, and the Windows 8 Professional operating system	720578-601
	For use only on computer models equipped with an AMD processor, a graphics subsystem with discrete memory, and the Windows 8 Standard operating system	720578-501
	For use only on computer models equipped with an AMD processor, a graphics subsystem with discrete memory, and the Linux operating system	720578-001
	For use only on computer models equipped with an AMD processor, a graphics subsystem with UMA memory, and the Windows 8 Professional operating system	720577-601
	For use only on computer models equipped with an AMD processor, a graphics subsystem with UMA memory, and the Windows 8 Standard operating system	720577-501
	For use only on computer models equipped with an AMD processor, a graphics subsystem with UMA memory, and the Linux operating system	720577-001
	For use only on computer models equipped with the Intel HM87 chipset, the GeForce 750M graphics subsystem, and the Windows 8 Professional operating system	720569-601
	For use only on computer models equipped with the Intel HM87 chipset, the GeForce 750M graphics subsystem, and the Windows 8 Standard operating system	720569-501

Item	Component	Spare part number
	For use only on computer models equipped with the Intel HM87 chipset, the GeForce 750M graphics subsystem, and the Linux operating system	720569-001
	For use only on computer models equipped with the Intel HM87 chipset, the GeForce 740M graphics subsystem, and the Windows 8 Professional operating system	720566-601
	For use only on computer models equipped with the Intel HM87 chipset, the GeForce 740M graphics subsystem, and the Windows 8 Standard operating system	720566-501
	For use only on computer models equipped with the Intel HM87 chipset, the GeForce 740M graphics subsystem, and the Linux operating system	720566-001
	For use only on computer models equipped with the Intel HM87 chipset, a graphics subsystem with UMA memory, and the Windows 8 Professional operating system	720565-601
	For use only on computer models equipped with the Intel HM87 chipset, a graphics subsystem with UMA memory, and the Windows 8 Standard operating system	720565-501
	For use only on computer models equipped with the Intel HM87 chipset, a graphics subsystem with UMA memory, and the Linux operating system	720565-001
	For use only on computer models equipped with the Intel HM77 chipset, the GeForce 740M graphics subsystem, and the Windows 8 Professional operating system	720567-601
	For use only on computer models equipped with the Intel HM77 chipset, the GeForce 740M graphics subsystem, and the Windows 8 Standard operating system	720567-501
	For use only on computer models equipped with the Intel HM77 chipset, the GeForce 740M graphics subsystem, and the Linux operating system	720567-001
	For use only on computer models equipped with the Intel HM77 chipset, a graphics subsystem with UMA memory, and the Windows 8 Professional operating system	720568-601
	For use only on computer models equipped with the Intel HM77 chipset, a graphics subsystem with UMA memory, and the Windows 8 Standard operating system	720568-501
	For use only on computer models equipped with the Intel HM77 chipset, a graphics subsystem with UMA memory, and the Linux operating system	720568-001
(12)	Processor (includes replacement thermal material):	
	AMD A10-5750M 2.50-GHz processor (turbo up to 3.50-GHz; 1600-MHz FSB, 4.0-MB L2 cache, DDR3, quad core, 35 W)	713548-001
	AMD A8-5550M 2.10-GHz processor (turbo up to 3.10-GHz; 1600-MHz FSB, 4.0-MB L2 cache, DDR3, quad core, 35 W)	713551-001
	AMD A6-5350M 2.90-GHz processor (turbo up to 3.50-GHz; 1600-MHz FSB, 1.0-MB L2 cache, DDR3, dual core, 35 W)	713550-001
	AMD A4-5150M 2.70-GHz processor (turbo up to 3.30-GHz; 1600-MHz FSB, 1.0-MB L2 cache, DDR3, dual core, 35 W)	713549-001
	Intel Quad Core i7-4900MQ 2.80-GHz processor (SC turbo up to 3.80-GHz; 1600-MHz FSB, 8.0-MB L3 cache, 47 W)	723523-001
	Intel Quad Core i7-4800MQ 2.70-GHz processor (SC turbo up to 3.70-GHz; 1600-MHz FSB, 6.0-MB L3 cache, 47 W)	723524-001
	Intel Quad Core i7-4702MQ 2.20-GHz processor (SC turbo up to 3.20-GHz; 1600-MHz FSB, 6.0-MB L3 cache, 37 W)	723522-001

Item	Component	Spare part number
	Intel Quad Core i7-4700MQ 2.40-GHz processor (SC turbo up to 3.40-GHz; 1600-MHz FSB, 6.0-MB L3 cache, 47 W)	723521-001
	Intel Dual Core i5-3380M 2.90-GHz processor (SC turbo up to 3.60-GHz; 1600-MHz FSB; 3.0-MB L3 cache, 35 W)	708762-001
	Intel Dual Core i5-3230M 2.60-GHz processor (SC turbo up to 3.20-GHz; 1600-MHz FSB, 3.0-MB L3 cache, 35 W)	711903-001
	Intel Dual Core i3-3130M 2.60-GHz processor (1600-MHz FSB, 3.0-MB L3 cache, 35 W)	713163-001
	Intel Dual Core i5-3120M 2.40-GHz processor (1600-MHz FSB, 3.0-MB L3 cache, 35 W)	700627-001
(13)	Heat sink (includes replacement thermal material):	
	For use only on computer models equipped with an AMD processor	720576-001
	For use only on computer models equipped with the Intel HM87 chipset and a GeForce 750M graphics subsystem	720542-001
	For use only on computer models equipped with the Intel HM87 chipset and a GeForce 740M graphics subsystem	722389-001
	For use only on computer models equipped with the Intel HM87 chipset and a graphics subsystem with UMA memory	720541-001
	For use only on computer models equipped with the Intel HM77 chipset and a graphics subsystem with discrete memory	720540-001
	For use only on computer models equipped with the Intel HM77 chipset and a graphics subsystem with UMA memory	720539-001
(14)	Fan (includes cable)	720235-001
(15)	Subwoofer (includes cable and 3 isolators)	720563-001
(16)	Front speakers (include left and right front speakers, 2 cables, and 4 isolators)	720562-001
(17)	Base enclosure (includes 4 rubber feet, battery lock latch, battery release latch, and RJ-45 cover)	720534-001
	Rubber Kit (not illustrated, includes front and rear rubber feet and display bezel rubber screw covers)	720559-001
(18)	RTC battery:	
	For use only on computer models equipped with an AMD processor	651948-001
	For use only on computer models equipped with an Intel processor	718440-001
(19)	WLAN module:	
	Atheros AR9485 802.11b/g/n WiFi Adapter for use on all computer models	675794-001
	Mediatek MT7630E 802.11bgn Wi-Fi Adapter and Mediatek Bluetooth 4.0 Adapter for use on all computer models	710418-001
	Ralink RT3290LE 802.11b/g/n 1×1 WiFi and Bluetooth 4.0 Combo Adapter for use on all computer models	690020-001

Item	Component	Spare part number
	Realtek RTL8188EE 802.11bgn Wi-Fi Adapter for use on all computer models	709848-001
	Intel Centrino Wireless-N 2230 Combo Adapter for use only on computer models equipped with an Intel processor	670290-001
(20)	24-GB solid-state drive (for use only on computer models equipped with an Intel processor)	720564-001
(21)	Memory module (PC3L, 12800, 1600-MHz):	
	8-GB	693374-001
	4-GB	691740-001
	2-GB	691739-001
(22)	Hard drive (does not include hard drive bracket or hard drive connector cable):	
	1-TB, 5400-rpm, 9.5-mm	676521-001
	750-GB, 5400-rpm, 9.5-mm	634250-001
	500-GB, 5400-rpm, 9.5- and 7.0-mm	683802-001
	Hard Drive Hardware Kit (not illustrated, includes hard drive bracket and hard drive connector cable)	720545-001
(23)	Battery:	
	6-cell, 62-Wh, 2.80-Ah, Li-ion battery	710417-001
	6-cell, 47-Wh, 2.20-Ah, Li-ion battery	710416-001
(24)	Service cover	720555-001

Display assembly subcomponents

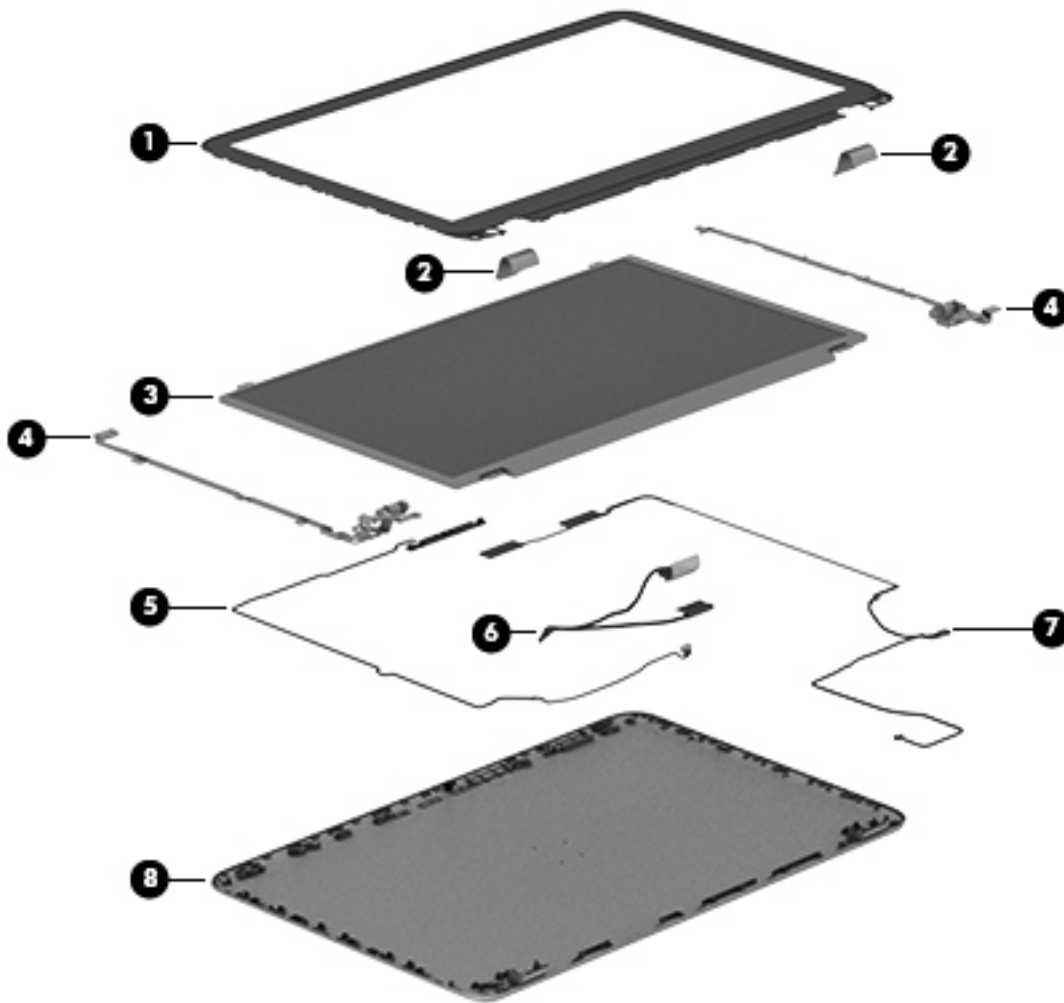

Item	Component	Spare part number
(1)	Display bezel	720535-001
(2)	Display hinges (includes left and right hinges, left and right hinge covers, and left and right hinge brackets)	720548-001
(3)	Webcam/microphone module (includes webcam/microphone module cable and double-sided adhesive)	720273-001
(4)	Display panel:	
	15.6-in, BrightView, FHD, LED, non-TouchScreen display panel	720557-001
	15.6-in, BrightView, HD, LED, non-TouchScreen display panel	720556-001
(5)	Display panel cable	720536-001
(6)	Antenna Kit (includes left and right wireless antenna cables and transceivers)	720532-001
(7)	Display enclosure	720533-001

Mass storage devices

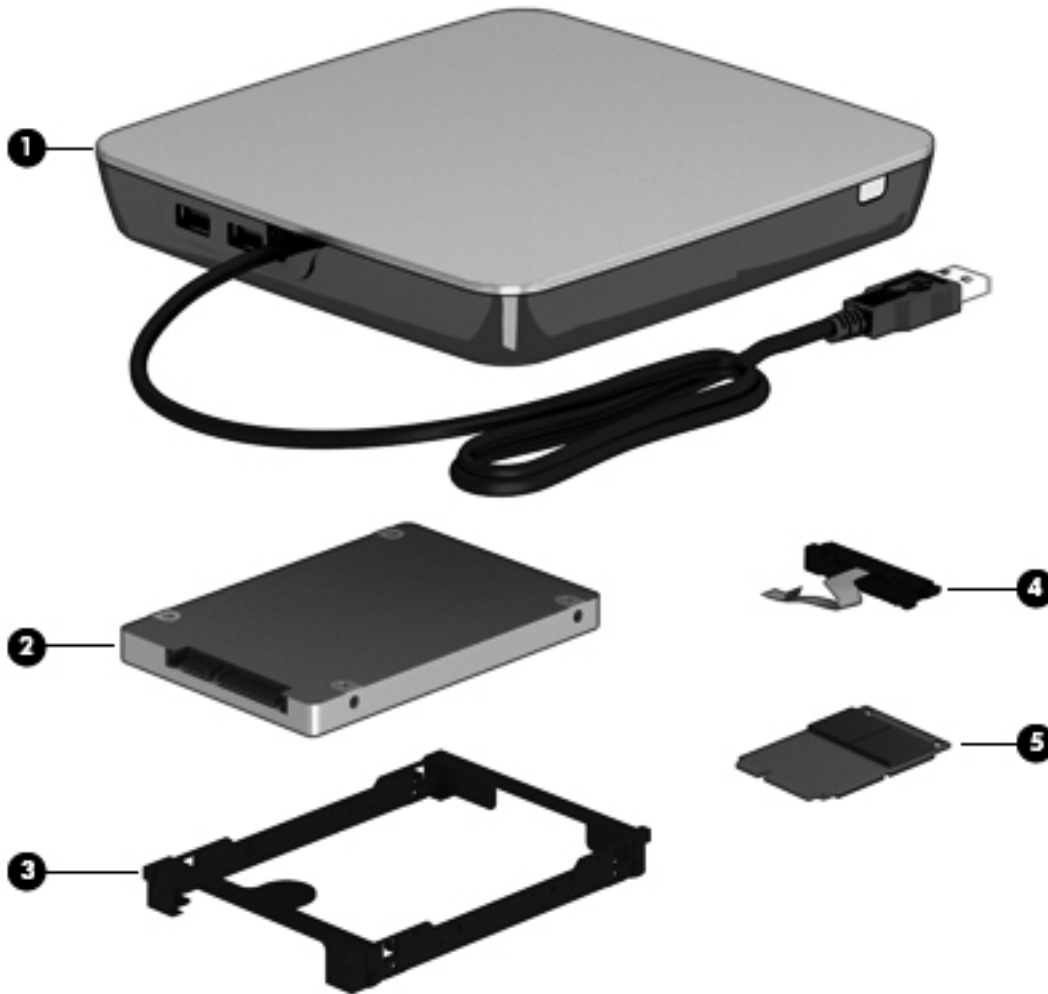

Item	Component	Spare part number
(1)	External DVD±RW Double-Layer with SuperMulti Drive	659940-001
(2)	Hard drive (does not include hard drive bracket or hard drive connector cable):	
	1-TB, 5400-rpm, 9.5-mm	676521-001
	750-GB, 5400-rpm, 9.5-mm	634250-001
	500-GB, 5400-rpm, 9.5- and 7.0-mm	683802-001
	Hard Drive Hardware Kit , includes:	720545-001
(3)	Hard drive bracket	
(4)	Hard drive connector cable	
(5)	24-GB solid-state drive (for use only on computer models equipped with an Intel processor)	720564-001

Miscellaneous parts

Component	Spare part number
AC adapter:	
120-W HP Slim AC adapter (PFC, EM, 4.5-mm) for use only on computer models equipped with an Intel processor	710415-001
65-W HP Smart AC adapter (non-PFC, 4.5-mm) for use on all computer models	710412-001
65-W HP Smart AC adapter (non-PFC, EM, 4.5-mm) for use only on computer models equipped with an Intel processor	714657-001
90-W HP Smart AC adapter (PFC, 4.5-mm) for use on all computer models	710413-001
90-W HP Smart AC adapter (PFC EM, 4.5-mm) for use only on computer models equipped with an Intel processor	710414-001
HDMI-to-VGA adapter	701943-001
Power cord (3-pin, black, 1.83-m):	
For use only on computer models equipped with an AMD processor in Argentina	490371-D01
For use on all computer models in Australia	490371-011
For use on all computer models in Denmark	490371-081
For use on all computer models in Europe	490371-021
For use only on computer models equipped with an Intel processor in India	490371-D61
For use only on computer models equipped with an Intel processor in Italy	490371-061
For use on all computer models in Japan	490371-291
For use on all computer models in North America	490371-001
For use only on computer models equipped with an Intel processor in Northwest Africa	490371-AR1
For use only on computer models equipped with an Intel processor in the People's Republic of China	490371-AA1
For use only on computer models equipped with an Intel processor in South Korea	490371-AD1
For use on all computer models in Switzerland	490371-111
For use only on computer models equipped with an Intel processor in Taiwan	490371-AB1
For use only on computer models equipped with an Intel processor in Thailand	490371-201
For use only on computer models equipped with an Intel processor in the United Kingdom and Singapore	490371-031
Screw Kit	720560-001

Sequential part number listing

Spare part number	Description
490371-001	Power cord for use on all computer models in North America (3-pin, black, 1.83-m)
490371-011	Power cord for use on all computer models in Australia (3-pin, black, 1.83-m)
490371-021	Power cord for use on all computer models in Europe (3-pin, black, 1.83-m)
490371-031	Power cord for use only on computer models equipped with an Intel processor in the United Kingdom and Singapore (3-pin, black, 1.83-m)
490371-061	Power cord for use only on computer models equipped with an Intel processor in Italy (3-pin, black, 1.83-m)
490371-081	Power cord for use on all computer models in Denmark (3-pin, black, 1.83-m)
490371-111	Power cord for use on all computer models in Switzerland (3-pin, black, 1.83-m)
490371-201	Power cord for use only on computer models equipped with an Intel processor in Thailand (3-pin, black, 1.83-m)
490371-291	Power cord for use on all computer models in Japan (3-pin, black, 1.83-m)
490371-AA1	Power cord for use only on computer models equipped with an Intel processor in the People's Republic of China (3-pin, black, 1.83-m)
490371-AB1	Power cord for use only on computer models equipped with an Intel processor in Taiwan (3-pin, black, 1.83-m)
490371-AD1	Power cord for use only on computer models equipped with an Intel processor in South Korea (3-pin, black, 1.83-m)
490371-AR1	Power cord for use only on computer models equipped with an Intel processor in Northwest Africa (3-pin, black, 1.83-m)
490371-D01	Power cord for use only on computer models equipped with an AMD processor in Argentina (3-pin, black, 1.83-m)
490371-D61	Power cord for use only on computer models equipped with an Intel processor in India (3-pin, black, 1.83-m)
634250-001	750-GB, 5400-rpm, SATA, 9.5-mm hard drive (does not include hard drive bracket or hard drive connector cable) NOTE: The hard drive bracket and screws are included in the Hard Drive Hardware Kit, spare part number HDHK-001.
651948-001	RTC battery for use only on computer models equipped with an AMD processor
659940-001	External DVD±RW Double-Layer with SuperMulti Drive
670290-001	Intel Centrino Wireless-N 2230 Combo Adapter
675794-001	Atheros AR9485 802.11b/g/n WiFi Adapter for use on all computer models
676521-001	1-TB, 5400-rpm, SATA, 9.5-mm hard drive (does not include hard drive bracket or hard drive connector cable) NOTE: The hard drive bracket and screws are included in the Hard Drive Hardware Kit, spare part number 718432-001.

Spare part number	Description
683802-001	500-GB, 5400-rpm, SATA, 9.5- and 7.0-mm hard drive (does not include hard drive bracket or hard drive connector cable) NOTE: The hard drive bracket and screws are included in the Hard Drive Hardware Kit, spare part number 718432-001.
690020-001	Ralink RT3290LE 802.11b/g/n 1x1 WiFi and Bluetooth 4.0 Combo Adapter
691739-001	2-GB memory module (PC3L, 12800, 1600-MHz)
691740-001	4-GB memory module (PC3L, 12800, 1600-MHz)
693374-001	8-GB memory module (PC3L, 12800, 1600-MHz)
700627-001	Intel Dual Core i5-3120M 2.40-GHz processor (1600-MHz FSB, 3.0-MB L3 cache, 35 W; includes replacement thermal material)
701943-001	HDMI-to-VGA adapter
708762-001	Intel Dual Core i5-3380M 2.90-GHz processor (SC turbo up to 3.60-GHz; 1600-MHz FSB; 3.0-MB L3 cache, 35 W; includes replacement thermal material)
709848-001	Realtek RTL8188EE 802.11bgn Wi-Fi Adapter for use on all computer models
710412-001	65-W HP Smart AC adapter (non-PFC, 4.5-mm) for use on all computer models
710413-001	90-W HP Smart AC adapter (PFC, 4.5-mm) for use on all computer models
710414-001	90-W HP Smart AC adapter (PFC EM, 4.5-mm) for use only on computer models equipped with an Intel processor
710415-001	120-W HP Slim AC adapter (PFC, EM, 4.5-mm) for use only on computer models equipped with an Intel processor
710416-001	6-cell, 47-Wh, 2.20-Ah, Li-ion battery
710417-001	6-cell, 62-Wh, 2.80-Ah, Li-ion battery
710418-001	Mediatek MT7630E 802.11bgn Wi-Fi Adapter and Mediatek Bluetooth 4.0 Adapter
711903-001	Intel Dual Core i5-3230M 2.60-GHz processor (SC turbo up to 3.20-GHz; 1600-MHz FSB, 3.0-MB L3 cache, 35 W; includes replacement thermal material)
713163-001	Intel Dual Core i3-3130M 2.60-GHz processor (1600-MHz FSB, 3.0-MB L3 cache, 35 W; includes replacement thermal material)
713548-001	AMD A10-5750M 2.50-GHz processor (turbo up to 3.50-GHz; 1600-MHz FSB, 4.0- MB L2 cache, DDR3, quad core, 35 W)
713549-001	AMD A4-5150M 2.70-GHz processor (turbo up to 3.30-GHz; 1600-MHz FSB, 1.0- MB L2 cache, DDR3, dual core, 35 W)
713550-001	AMD A6-5350M 2.90-GHz processor (turbo up to 3.50-GHz; 1600-MHz FSB, 1.0- MB L2 cache, DDR3, dual core, 35 W)
713551-001	AMD A8-5550M 2.10-GHz processor (turbo up to 3.10-GHz; 1600-MHz FSB, 4.0- MB L2 cache, DDR3, quad core, 35 W)
714657-001	65-W HP Smart AC adapter (non-PFC, EM, 4.5-mm) for use only on computer models equipped with an Intel processor
718440-001	RTC battery for use only on computer models equipped with an Intel processor

Spare part number	Description
720235-001	Fan (includes cable)
720242-001	Keyboard with pointing stick for use on all computer models in the United States (includes keyboard cable and pointing stick cable)
720244-001	Keyboard with backlight for use on all computer models in the United States (includes backlight cable and keyboard cable)
720244-031	Keyboard with backlight for use only on computer models equipped with an Intel processor in the United Kingdom in Singapore (includes backlight cable and keyboard cable)
720244-041	Keyboard with backlight for use only on computer models equipped with an Intel processor in France (includes backlight cable and keyboard cable)
720244-051	Keyboard with backlight for use only on computer models equipped with an Intel processor in Germany (includes backlight cable and keyboard cable)
720244-061	Keyboard with backlight for use only on computer models equipped with an Intel processor in Italy (includes backlight cable and keyboard cable)
720244-071	Keyboard with backlight for use only on computer models equipped with an Intel processor in Spain (includes backlight cable and keyboard cable)
720244-131	Keyboard with backlight for use only on computer models equipped with an Intel processor in Portugal (includes backlight cable and keyboard cable)
720244-141	Keyboard with backlight for use only on computer models equipped with an Intel processor in Turkey (includes backlight cable and keyboard cable)
720244-151	Keyboard with backlight for use only on computer models equipped with an Intel processor in Greece (includes backlight cable and keyboard cable)
720244-161	Keyboard with backlight for use on all computer models in Latin America (includes backlight cable and keyboard cable)
720244-171	Keyboard with backlight for use only on computer models equipped with an Intel processor in Saudi Arabia (includes backlight cable and keyboard cable)
720244-251	Keyboard with backlight for use only on computer models equipped with an Intel processor in Russia (includes backlight cable and keyboard cable)
720244-281	Keyboard with backlight for use only on computer models equipped with an Intel processor in Thailand (includes backlight cable and keyboard cable)
720244-291	Keyboard with backlight for use on all computer models in Japan (includes backlight cable and keyboard cable)
720244-A41	Keyboard with backlight for use only on computer models equipped with an Intel processor in Belgium (includes backlight cable and keyboard cable)
720244-AB1	Keyboard with backlight for use only on computer models equipped with an Intel processor in Taiwan (includes backlight cable and keyboard cable)
720244-AD1	Keyboard with backlight for use only on computer models equipped with an Intel processor in South Korea (includes backlight cable and keyboard cable)
720244-B31	Keyboard with backlight for use only on computer models equipped with an Intel processor in the Netherlands (includes backlight cable and keyboard cable)
720244-BG1	Keyboard with backlight for use only on computer models equipped with an Intel processor in Switzerland (includes backlight cable and keyboard cable)

Spare part number	Description
720244-DB1	Keyboard with backlight for use on all computer models in Canada (includes backlight cable and keyboard cable)
720244-DH1	Keyboard with backlight for use only on computer models equipped with an Intel processor in Denmark, Finland, and Norway (includes backlight cable and keyboard cable)
720244-FL1	Keyboard with backlight for use only on computer models equipped with an Intel processor in the Czech Republic and Slovakia (includes backlight cable and keyboard cable)
720273-001	Webcam/microphone module (includes webcam/microphone module cable and double-sided adhesive)
720532-001	Antenna Kit (includes left and right wireless antenna cables and transceivers)
720533-001	Display enclosure
720534-001	Base enclosure (includes 4 rubber feet, battery lock latch, battery release latch, and RJ-45 cover)
720535-001	Display bezel
720536-001	Display panel cable (includes webcam/microphone module cable)
720537-001	Power connector cable for use on all computer models equipped with a graphics subsystem with UMA memory
720538-001	Power connector cable for use only on computer models equipped with an Intel processor and a graphics subsystem with discrete memory
720539-001	Heat sink for use only on computer models equipped with the Intel HM77 chipset and a graphics subsystem with UMA memory (includes replacement material)
720540-001	Heat sink for use only on computer models equipped with the Intel HM77 chipset and a graphics subsystem with discrete memory (includes replacement material)
720541-001	Heat sink for use only on computer models equipped with the Intel HM87 chipset and a graphics subsystem with UMA memory (includes replacement material)
720542-001	Heat sink for use only on computer models equipped with the Intel HM87 chipset and a GeForce 750M graphics subsystem (includes replacement material)
720543-001	Fingerprint reader board (includes bracket and cable)
720544-001	Keyboard shield
720545-001	Hard Drive Hardware Kit (includes hard drive bracket and hard drive connector cable)
720547-001	Counterbalance weight
720548-001	Display hinge (includes left and right hinges, left and right hinge covers, and left and right hinge brackets)
720549-001	15.6-in, BrightView, HD, LED, TouchScreen display assembly (includes webcamera/microphone module and wireless antenna cables)
720550-001	15.6-in, BrightView, FHD, LED, TouchScreen display assembly (includes webcamera/microphone module and wireless antenna cables)
720551-001	15.6-in, BrightView, HD, LED, non-TouchScreen display assembly (includes webcamera/microphone module and wireless antenna cables)
720552-001	15.6-in, BrightView, FHD, LED, non-TouchScreen display assembly (includes webcamera/microphone module and wireless antenna cables)

Spare part number	Description
720553-001	Power button board (includes cable)
720554-001	Connector board for use only on computer models equipped with an Intel processor and a graphics subsystem with UMA memory (includes 2 cables)
720555-001	Service cover
720556-001	15.6-in, BrightView, HD, LED, non-TouchScreen display panel
720557-001	15.6-in, BrightView, FHD, LED, non-TouchScreen display panel
720559-001	Rubber Kit (includes front and rear rubber feet and display bezel rubber screw covers)
720560-001	Screw Kit
720561-001	Rear speakers (includes cables and 4 rubber isolators)
720562-001	Front speakers (includes cables and 4 rubber isolators)
720563-001	Subwoofer (includes cable and 3 rubber isolators)
720564-001	24-GB solid-state drive (for use only on computer models equipped with an Intel processor)
720565-001	System board for use only on computer models equipped with the Intel HM87 chipset, a graphics subsystem with UMA memory, and the Linux operating system (includes replacement material)
720565-501	System board for use only on computer models equipped with the Intel HM87 chipset, a graphics subsystem with UMA memory, and the Windows 8 Standard operating system (includes replacement material)
720565-601	System board for use only on computer models equipped with the Intel HM87 chipset, a graphics subsystem with UMA memory, and the Windows 8 Professional operating system (includes replacement material)
720566-001	System board for use only on computer models equipped with the Intel HM87 chipset, the GeForce 740M graphics subsystem, and the Linux operating system (includes replacement material)
720566-501	System board for use only on computer models equipped with the Intel HM87 chipset, the GeForce 740M graphics subsystem, and the Windows 8 Standard operating system (includes replacement material)
720566-601	System board for use only on computer models equipped with the Intel HM87 chipset, the GeForce 740M graphics subsystem, and the Windows 8 Professional operating system (includes replacement material)
720567-001	System board for use only on computer models equipped with the Intel HM77 chipset, the GeForce 740M graphics subsystem, and the Linux operating system (includes replacement material)
720567-501	System board for use only on computer models equipped with the Intel HM77 chipset, the GeForce 740M graphics subsystem, and the Windows 8 Standard operating system (includes replacement material)
720567-601	System board for use only on computer models equipped with the Intel HM77 chipset, the GeForce 740M graphics subsystem, and the Windows 8 Professional operating system (includes replacement material)
720568-001	System board for use only on computer models equipped with the Intel HM77 chipset, a graphics subsystem with UMA memory, and the Linux operating system (includes replacement material)
720568-501	System board for use only on computer models equipped with the Intel HM77 chipset, a graphics subsystem with UMA memory, and the Windows 8 Standard operating system (includes replacement material)

Spare part number	Description
720568-601	System board for use only on computer models equipped with the Intel HM77 chipset, a graphics subsystem with UMA memory, and the Windows 8 Professional operating system (includes replacement material)
720569-001	System board for use only on computer models equipped with the Intel HM87 chipset, the GeForce 750M graphics subsystem, and the Linux operating system (includes replacement material)
720569-501	System board for use only on computer models equipped with the Intel HM87 chipset, the GeForce 750M graphics subsystem, and the Windows 8 Standard operating system (includes replacement material)
720569-601	System board for use only on computer models equipped with the Intel HM87 chipset, the GeForce 750M graphics subsystem, and the Windows 8 Professional operating system (includes replacement material)
720570-001	Top cover
720576-001	Heat sink for use only on computer models equipped with an AMD processor (includes replacement material)
720577-001	System board for use only on computer models equipped with an AMD processor, a graphics subsystem with UMA memory, and the Linux operating system (includes replacement thermal material)
720577-501	System board for use only on computer models equipped with an AMD processor, a graphics subsystem with UMA memory, and the Windows 8 Standard operating system (includes replacement thermal material)
720577-601	System board for use only on computer models equipped with an AMD processor, a graphics subsystem with UMA memory, and the Windows 8 Professional operating system (includes replacement thermal material)
720578-001	System board for use only on computer models equipped with an AMD processor, a graphics subsystem with discrete memory, and the Linux operating system (includes replacement thermal material)
720578-501	System board for use only on computer models equipped with an AMD processor, a graphics subsystem with discrete memory, and the Windows 8 Standard operating system (includes replacement thermal material)
720578-601	System board for use only on computer models equipped with an AMD processor, a graphics subsystem with discrete memory, and the Windows 8 Professional operating system (includes replacement thermal material)
720579-001	Connector board for use only on computer models equipped with an AMD processor (includes 2 cables)
722389-001	Heat sink for use only on computer models equipped with the Intel HM87 chipset and a GeForce 740M graphics subsystem (includes replacement material)
722972-001	TouchPad assembly (includes TouchPad bracket, TouchPad button board, TouchPad, and cables)
723372-001	Connector board for use only on computer models equipped with an Intel processor and a graphics subsystem with discrete memory (includes 2 cables)
723521-001	Intel Quad Core i7-4700MQ 2.40-GHz processor (SC turbo up to 3.40-GHz; 1600-MHz FSB, 6.0-MB L3 cache, 47 W; includes replacement thermal material)
723522-001	Intel Quad Core i7-4702MQ 2.20-GHz processor (SC turbo up to 3.20-GHz; 1600-MHz FSB, 6.0-MB L3 cache, 37 W; includes replacement thermal material)

Spare part number	Description
723523-001	Intel Quad Core i7-4900MQ 2.80-GHz processor (SC turbo up to 3.80-GHz; 1600-MHz FSB, 8.0-MB L3 cache, 47 W; includes replacement thermal material)
723524-001	Intel Quad Core i7-4800MQ 2.70-GHz processor (SC turbo up to 3.70-GHz; 1600-MHz FSB, 6.0-MB L3 cache, 47 W; includes replacement thermal material)

4 Removal and replacement procedures preliminary requirements

Tools required

You will need the following tools to complete the removal and replacement procedures:

- Flat-bladed screw driver
- Magnetic screw driver
- Phillips P0 and P1 screw drivers

Service considerations

The following sections include some of the considerations that you must keep in mind during disassembly and assembly procedures.

 **NOTE:** As you remove each subassembly from the computer, place the subassembly (and all accompanying screws) away from the work area to prevent damage.

Plastic parts

 **CAUTION:** Using excessive force during disassembly and reassembly can damage plastic parts. Use care when handling the plastic parts. Apply pressure only at the points designated in the maintenance instructions.

Cables and connectors

⚠ CAUTION: When servicing the computer, be sure that cables are placed in their proper locations during the reassembly process. Improper cable placement can damage the computer.

Cables must be handled with extreme care to avoid damage. Apply only the tension required to unseat or seat the cables during removal and insertion. Handle cables by the connector whenever possible. In all cases, avoid bending, twisting, or tearing cables. Be sure that cables are routed in such a way that they cannot be caught or snagged by parts being removed or replaced. Handle flex cables with extreme care; these cables tear easily.

Drive handling

⚠ CAUTION: Drives are fragile components that must be handled with care. To prevent damage to the computer, damage to a drive, or loss of information, observe these precautions:

Before removing or inserting a hard drive, shut down the computer. If you are unsure whether the computer is off or in Hibernation, turn the computer on, and then shut it down through the operating system.

Before handling a drive, be sure that you are discharged of static electricity. While handling a drive, avoid touching the connector.

Before removing a diskette drive or optical drive, be sure that a diskette or disc is not in the drive and be sure that the optical drive tray is closed.

Handle drives on surfaces covered with at least one inch of shock-proof foam.

Avoid dropping drives from any height onto any surface.

After removing a hard drive, an optical drive, or a diskette drive, place it in a static-proof bag.

Avoid exposing an internal hard drive to products that have magnetic fields, such as monitors or speakers.

Avoid exposing a drive to temperature extremes or liquids.

If a drive must be mailed, place the drive in a bubble pack mailer or other suitable form of protective packaging and label the package "FRAGILE."

Grounding guidelines

Electrostatic discharge damage

Electronic components are sensitive to electrostatic discharge (ESD). Circuitry design and structure determine the degree of sensitivity. Networks built into many integrated circuits provide some protection, but in many cases, ESD contains enough power to alter device parameters or melt silicon junctions.

A discharge of static electricity from a finger or other conductor can destroy static-sensitive devices or microcircuitry. Even if the spark is neither felt nor heard, damage may have occurred.

An electronic device exposed to ESD may not be affected at all and can work perfectly throughout a normal cycle. Or the device may function normally for a while, then degrade in the internal layers, reducing its life expectancy.

⚠ CAUTION: To prevent damage to the computer when you are removing or installing internal components, observe these precautions:

Keep components in their electrostatic-safe containers until you are ready to install them.

Before touching an electronic component, discharge static electricity by using the guidelines described in this section.

Avoid touching pins, leads, and circuitry. Handle electronic components as little as possible.

If you remove a component, place it in an electrostatic-safe container.

The following table shows how humidity affects the electrostatic voltage levels generated by different activities.

⚠ CAUTION: A product can be degraded by as little as 700 V.

Typical electrostatic voltage levels			
Event	Relative humidity		
	10%	40%	55%
Walking across carpet	35,000 V	15,000 V	7,500 V
Walking across vinyl floor	12,000 V	5,000 V	3,000 V
Motions of bench worker	6,000 V	800 V	400 V
Removing DIPS from plastic tube	2,000 V	700 V	400 V
Removing DIPS from vinyl tray	11,500 V	4,000 V	2,000 V
Removing DIPS from Styrofoam	14,500 V	5,000 V	3,500 V
Removing bubble pack from PCB	26,500 V	20,000 V	7,000 V
Packing PCBs in foam-lined box	21,000 V	11,000 V	5,000 V

Packaging and transporting guidelines

Follow these grounding guidelines when packaging and transporting equipment:

- To avoid hand contact, transport products in static-safe tubes, bags, or boxes.
- Protect ESD-sensitive parts and assemblies with conductive or approved containers or packaging.
- Keep ESD-sensitive parts in their containers until the parts arrive at static-free workstations.
- Place items on a grounded surface before removing items from their containers.
- Always be properly grounded when touching a component or assembly.
- Store reusable ESD-sensitive parts from assemblies in protective packaging or nonconductive foam.
- Use transporters and conveyors made of antistatic belts and roller bushings. Be sure that mechanized equipment used for moving materials is wired to ground and that proper materials are selected to avoid static charging. When grounding is not possible, use an ionizer to dissipate electric charges.

Workstation guidelines

Follow these grounding workstation guidelines:

- Cover the workstation with approved static-shielding material.
- Use a wrist strap connected to a properly grounded work surface and use properly grounded tools and equipment.
- Use conductive field service tools, such as cutters, screw drivers, and vacuums.
- When fixtures must directly contact dissipative surfaces, use fixtures made only of static-safe materials.
- Keep the work area free of nonconductive materials, such as ordinary plastic assembly aids and Styrofoam.
- Handle ESD-sensitive components, parts, and assemblies by the case or PCM laminate. Handle these items only at static-free workstations.
- Avoid contact with pins, leads, or circuitry.
- Turn off power and input signals before inserting or removing connectors or test equipment.

Equipment guidelines

Grounding equipment must include either a wrist strap or a foot strap at a grounded workstation.

- When seated, wear a wrist strap connected to a grounded system. Wrist straps are flexible straps with a minimum of one megohm $\pm 10\%$ resistance in the ground cords. To provide proper ground, wear a strap snugly against the skin at all times. On grounded mats with banana-plug connectors, use alligator clips to connect a wrist strap.
- When standing, use foot straps and a grounded floor mat. Foot straps (heel, toe, or boot straps) can be used at standing workstations and are compatible with most types of shoes or boots. On conductive floors or dissipative floor mats, use foot straps on both feet with a minimum of one megohm resistance between the operator and ground. To be effective, the conductive must be worn in contact with the skin.

The following grounding equipment is recommended to prevent electrostatic damage:

- Antistatic tape
- Antistatic smocks, aprons, and sleeve protectors
- Conductive bins and other assembly or soldering aids
- Nonconductive foam
- Conductive tabletop workstations with ground cords of one megohm resistance
- Static-dissipative tables or floor mats with hard ties to the ground
- Field service kits
- Static awareness labels
- Material-handling packages
- Nonconductive plastic bags, tubes, or boxes
- Metal tote boxes
- Electrostatic voltage levels and protective materials

The following table lists the shielding protection provided by antistatic bags and floor mats.

Material	Use	Voltage protection level
Antistatic plastics	Bags	1,500 V
Carbon-loaded plastic	Floor mats	7,500 V
Metallized laminate	Floor mats	5,000 V

5 Removal and replacement procedures for Customer Self-Repair parts

 **NOTE:** The Customer Self-Repair program is not available in all locations. Installing a part not supported by the Customer Self-Repair program may void your warranty. Check your warranty to determine if Customer Self-Repair is supported in your location.

Component replacement procedures

 **NOTE:** Please read and follow the procedures described here to access and replace Customer Self-Repair parts successfully.

 **NOTE:** Details about your computer, including model, serial number, product key, and length of warranty, are on the service tag at the bottom of your computer. See Service tag on page 16 for details.

This chapter provides removal and replacement procedures for Customer Self-Repair parts.

There are as many as 4 screws that must be removed, replaced, and/or loosened when servicing Customer Self-Repair parts. Make special note of each screw size and location during removal and replacement.

Battery

Description	Spare part number
6-cell, 62-Wh, 2.80-Ah, Li-ion battery	710417-001
6-cell, 47-Wh, 2.20-Ah, Li-ion battery	710416-001

Before removing the battery, follow these steps:

1. Turn off the computer. If you are unsure whether the computer is off or in Hibernation, turn the computer on, and then shut it down through the operating system.
2. Disconnect the power from the computer by unplugging the power cord from the computer.
3. Disconnect all external devices from the computer.

Remove the battery:

⚠ WARNING! To reduce potential safety issues, use only the user-replaceable battery provided with the computer, a replacement battery provided by HP, or a compatible battery purchased from HP.

⚠ CAUTION: Removing a user-replaceable battery that is the sole power source for the computer can cause loss of information. To prevent loss of information, save your work or shut down the computer through Windows before removing the battery.

1. Turn the computer upside down on a flat surface.
2. Slide the battery release latch **(1)** to release the battery.

📝 NOTE: The battery release latch automatically returns to its original position.

3. Pivot the battery **(2)** upward.
4. Remove the battery **(3)** from the computer.

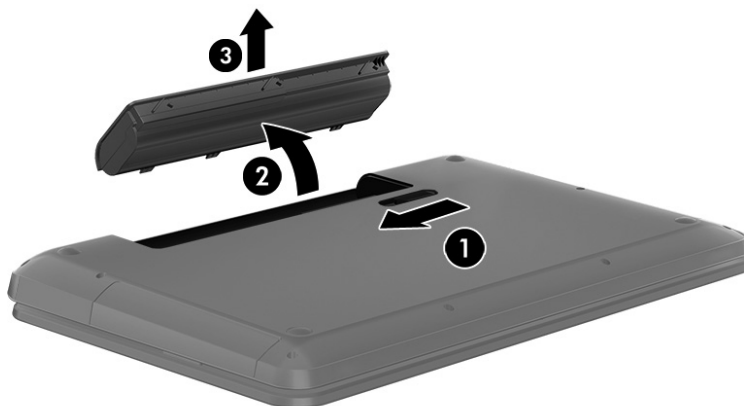

Reverse this procedure to install the battery.

Solid-state drive

 **NOTE:** This section applies only to computer models equipped with an Intel processor.

Description	Spare part number
24-GB solid-state drive	720564-001

Before removing the solid-state drive, follow these steps:

1. Turn off the computer. If you are unsure whether the computer is off or in Hibernation, turn the computer on, and then shut it down through the operating system.
2. Disconnect the power from the computer by unplugging the power cord from the computer.
3. Disconnect all external devices from the computer.
4. Remove the battery (see [Battery on page 43](#)).

Remove the solid-state drive:

1. Loosen the Phillips PM2.0×4.0 captive screw **(1)** that secures the service cover to the computer.
2. Lift the rear edge of the service cover **(2)** and swing it up and forward until it disengages from the computer.
3. Remove the service cover **(3)**.

The service cover is available using spare part number 720555-001.

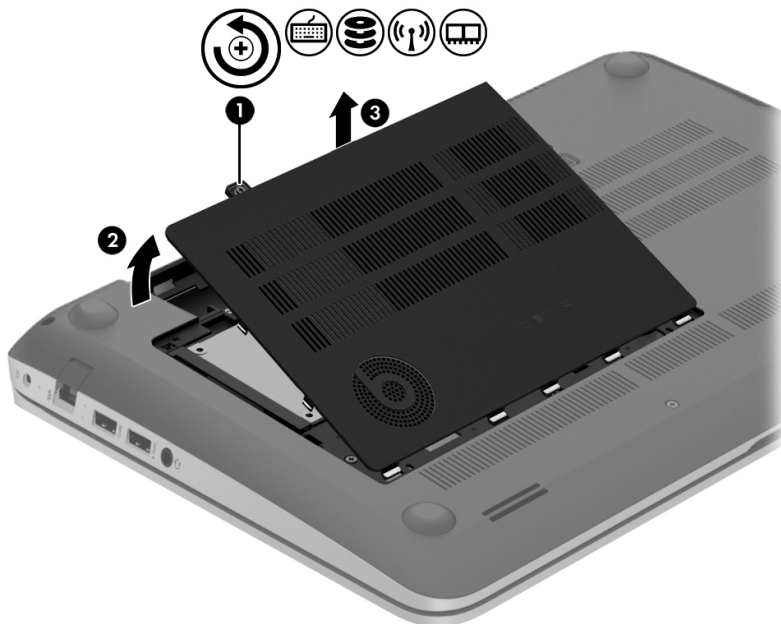

4. Remove the two Phillips PM2.0×2.5 screws **(1)** that secure the solid-state drive to the system board. (The solid-state drive tilts up.)

5. Remove the solid-state drive (2) by pulling the drive away from the slot at an angle.

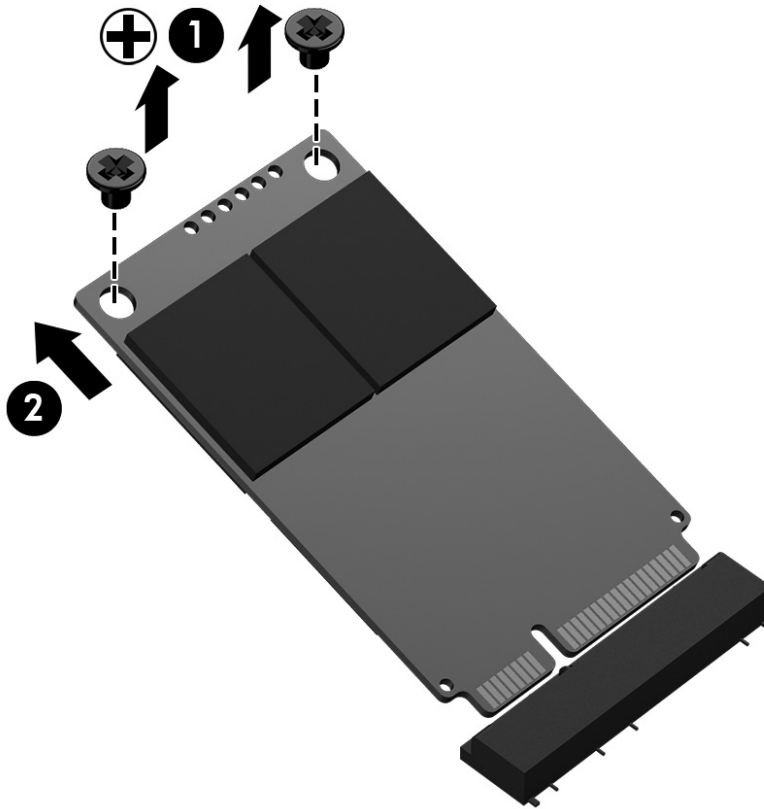

Reverse this procedure to install the solid-state drive.

WLAN module

Description	Spare part number
Atheros AR9485 802.11b/g/n WiFi Adapter for use on all computer models	675794-001
Mediatek MT7630E 802.11bgn Wi-Fi Adapter and Mediatek Bluetooth 4.0 Adapter for use on all computer models	710418-001
Ralink RT3290LE 802.11b/g/n 1x1 WiFi and Bluetooth 4.0 Combo Adapter for use on all computer models	690020-001
Realtek RTL8188EE 802.11bgn Wi-Fi Adapter for use on all computer models	709848-001
Intel Centrino Wireless-N 2230 Combo Adapter for use only on computer models equipped with an Intel processor	670290-001

CAUTION: To prevent an unresponsive system, replace the wireless module only with a wireless module authorized for use in the computer by the governmental agency that regulates wireless devices in your country or region. If you replace the module and then receive a warning message, remove the module to restore device functionality, and then contact technical support.

Before removing the WLAN module, follow these steps:

1. Turn off the computer. If you are unsure whether the computer is off or in Hibernation, turn the computer on, and then shut it down through the operating system.
2. Disconnect the power from the computer by unplugging the power cord from the computer.
3. Disconnect all external devices from the computer.
4. Remove the battery (see [Battery on page 43](#)).
5. Remove the service cover (see [Solid-state drive on page 44](#)).

Remove the WLAN module:

1. Disconnect the WLAN antenna cables **(1)** from the terminals on the WLAN module.

 **NOTE:** The WLAN antenna cable labeled “1” connects to the WLAN module “Main” terminal labeled “1”. The WLAN antenna cable labeled “2” connects to the WLAN module “Aux” terminal labeled “2”.

2. Remove the Phillips PM2.0×2.5 screw **(2)** that secures the WLAN module to the system board. (The WLAN module tilts up.)
3. Remove the WLAN module **(3)** by pulling the module away from the slot at an angle.

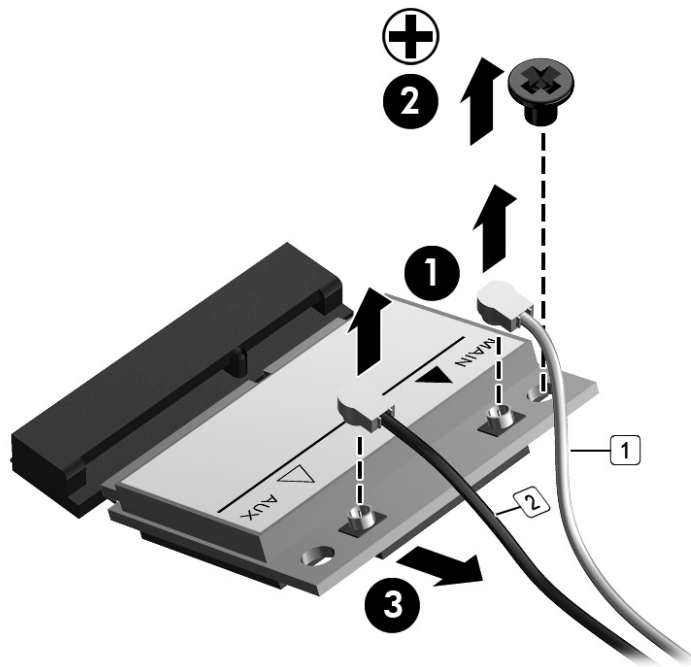

 **NOTE:** If the WLAN antenna cables are not connected to the terminals on the WLAN module, the protective sleeves must be installed on the antenna connectors, as shown in the following illustration.

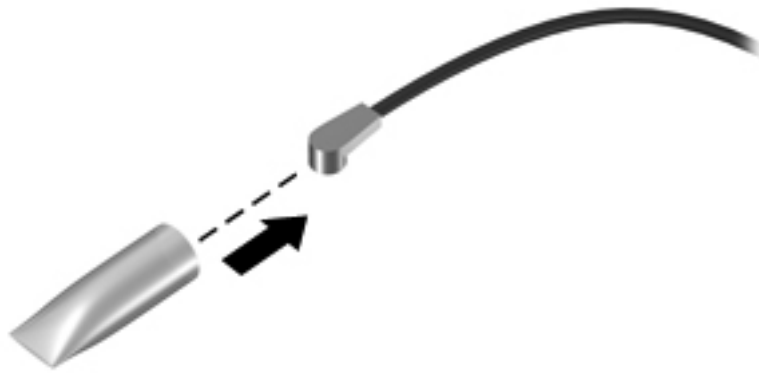

Reverse this procedure to install the WLAN module.

Hard drive

Description	Spare part number
1-TB, 5400-rpm, 9.5-mm	676521-001
750-GB, 5400-rpm, 9.5-mm	634250-001
500-GB, 5400-rpm, 9.5- and 7.0-mm	683802-001

Before removing the hard drive, follow these steps:

1. Turn off the computer. If you are unsure whether the computer is off or in Hibernation, turn the computer on, and then shut it down through the operating system.
2. Disconnect the power from the computer by unplugging the power cord from the computer.
3. Disconnect all external devices from the computer.
4. Remove the battery (see [Battery on page 43](#)).
5. Remove the service cover (see [Solid-state drive on page 44](#)).

Remove the hard drive:

1. Release the zero insertion force (ZIF) connector **(1)** to which the hard drive connector cable is attached, and then disconnect the hard drive connector cable **(2)** from the system board.
2. Release the hard drive connector cable **(3)** from the opening in the base enclosure.

3. Lift up on the hard drive tab **(4)** to remove the hard drive from the hard drive bay.

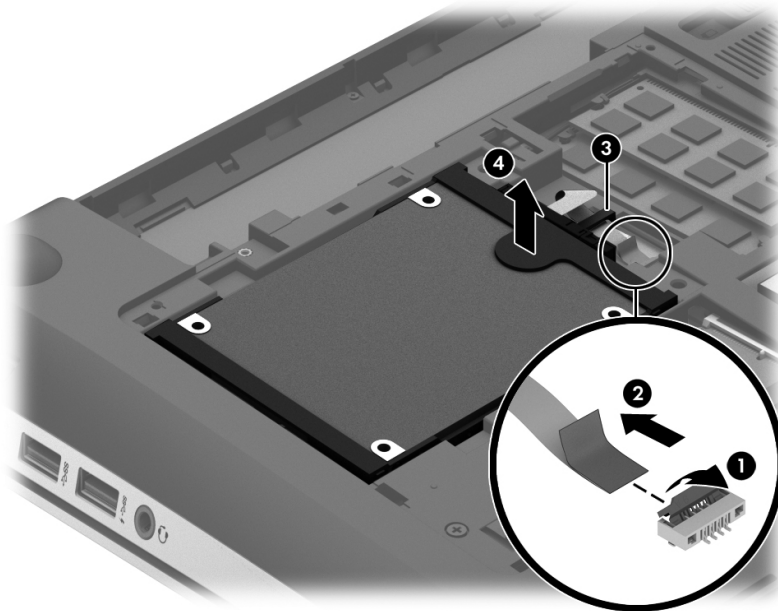

4. If it is necessary to disassemble the hard drive, perform the following steps:
 - a. Position the hard drive with the connector toward you.
 - b. Disconnect the hard drive connector cable **(1)** from the hard drive.
 - c. Spread the left and right sides **(2)** of the hard drive bracket outward to separate the bracket from the hard drive.
 - d. Remove the hard drive bracket **(3)** from the hard drive.

The hard drive bracket and hard drive connector cable are available in the Hard Drive Hardware Kit, spare part number 718432-001.

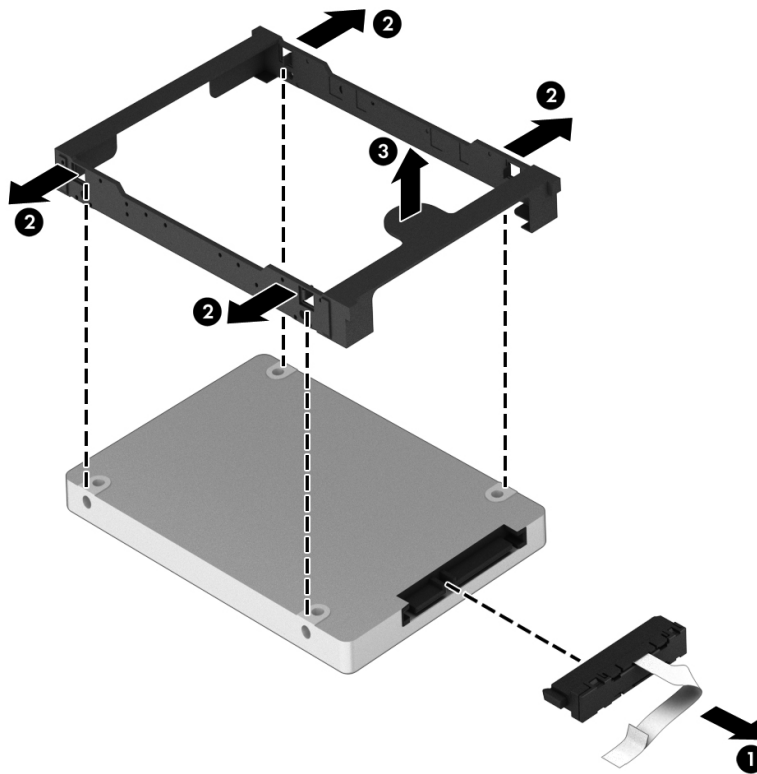

Reverse this procedure to install the RTC battery.

Memory module

Description	Spare part number
8-GB (PC3L, 12800, 1600-MHz)	693374-001
4-GB (PC3L, 12800, 1600-MHz)	691740-001
2-GB (PC3L, 12800, 1600-MHz)	691739-001

Update BIOS before adding memory modules

Before adding new memory, make sure you update the computer to the latest BIOS.

CAUTION: Failure to update the computer to the latest BIOS prior to installing new memory may result in various system problems.

To update BIOS:

1. Navigate to www.hp.com.
2. Click **Support & Drivers** > click **Drivers & Software**.
3. In the **Enter a product name/number box**, type the computer model information, and then click **Search**.

4. Click the link for the computer model.
5. Select the operating system, and then click **Next**.
6. Under **Step 2: Select a Download**, click the **BIOS** link.
7. Click the link for the most recent BIOS.
8. Click the **Download** button, and then follow the on-screen instructions.

Before removing a memory module, follow these steps:

1. Turn off the computer. If you are unsure whether the computer is off or in Hibernation, turn the computer on, and then shut it down through the operating system.
2. Disconnect the power from the computer by unplugging the power cord from the computer.
3. Disconnect all external devices from the computer.
4. Remove the battery (see [Battery on page 43](#)).
5. Remove the service cover (see [Solid-state drive on page 44](#)).

Remove the memory module:

1. Lift the left edge of the memory module shield and swing it up and to the right until the memory modules are accessible.

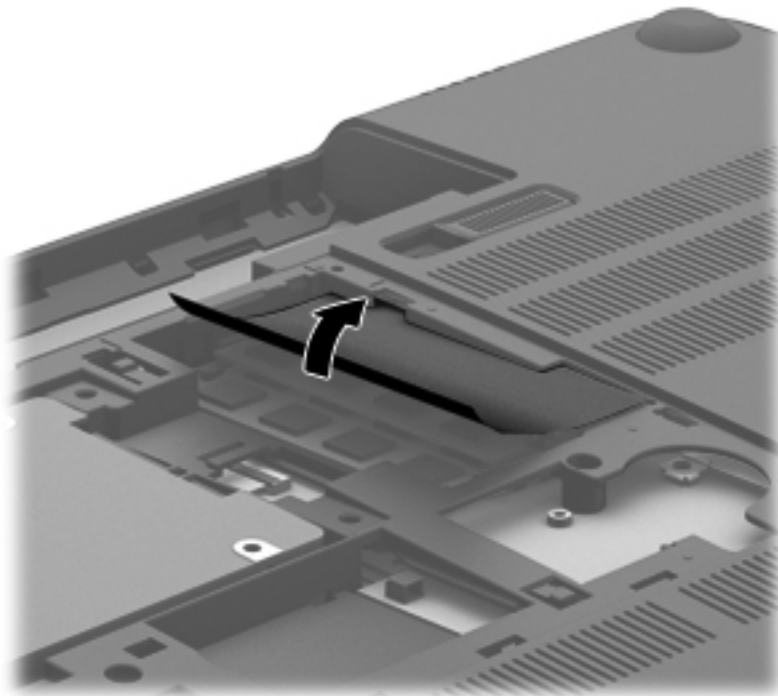

2. Spread the retaining tabs **(1)** on each side of the memory module slot to release the memory module. (The memory module tilts up.)

3. Remove the memory module **(2)** by pulling the module away from the slot at an angle.

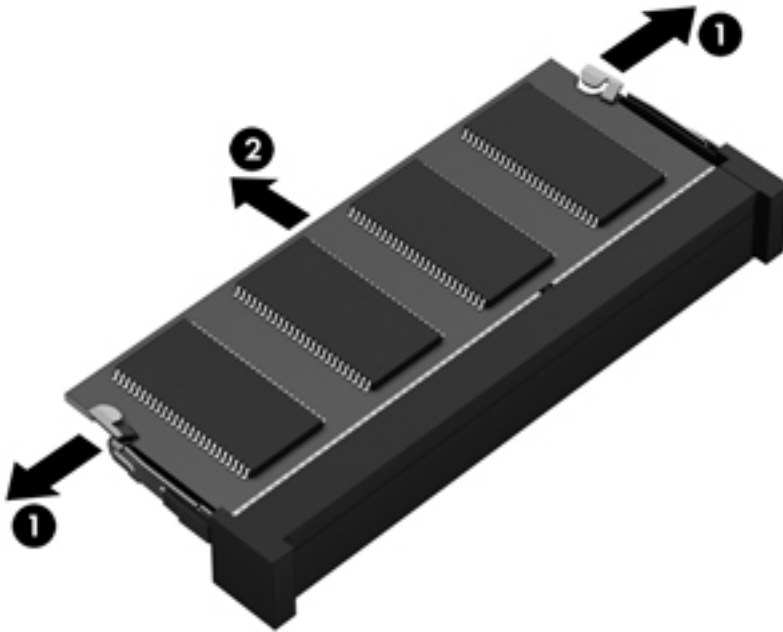

Reverse this procedure to install a memory module.

6 Removal and replacement procedures for Authorized Service Provider parts

⚠ CAUTION: Components described in this chapter should only be accessed by an authorized service provider. Accessing these parts can damage the computer or void the warranty.

Component replacement procedures

This chapter provides removal and replacement procedures for Authorized Service Provider only parts.

There are as many as 94 screws that must be removed, replaced, and/or loosened when servicing the computer. Make special note of each screw size and location during removal and replacement.

RTC battery

Description	Spare part number
For use only on computer models equipped with an AMD processor	651948-001
For use only on computer models equipped with an Intel processor	718440-001

Before removing the RTC battery, follow these steps:

1. Turn off the computer. If you are unsure whether the computer is off or in Hibernation, turn the computer on, and then shut it down through the operating system.
2. Disconnect the power from the computer by unplugging the power cord from the computer.
3. Disconnect all external devices from the computer.
4. Remove the battery (see [Battery on page 43](#)).
5. Remove the service cover (see [Solid-state drive on page 44](#)).

Remove the RTC battery:

 **NOTE:** If the computer is equipped with an AMD processor, complete steps 1 through 3 to remove the RTC battery. If the computer is equipped with an Intel processor, complete step 4 to remove the RTC battery.

1. Disconnect the RTC battery cable **(1)** from the system board.
2. Detach the RTC battery **(2)** from the base enclosure. (The RTC battery is attached to the base enclosure by double-sided tape.)

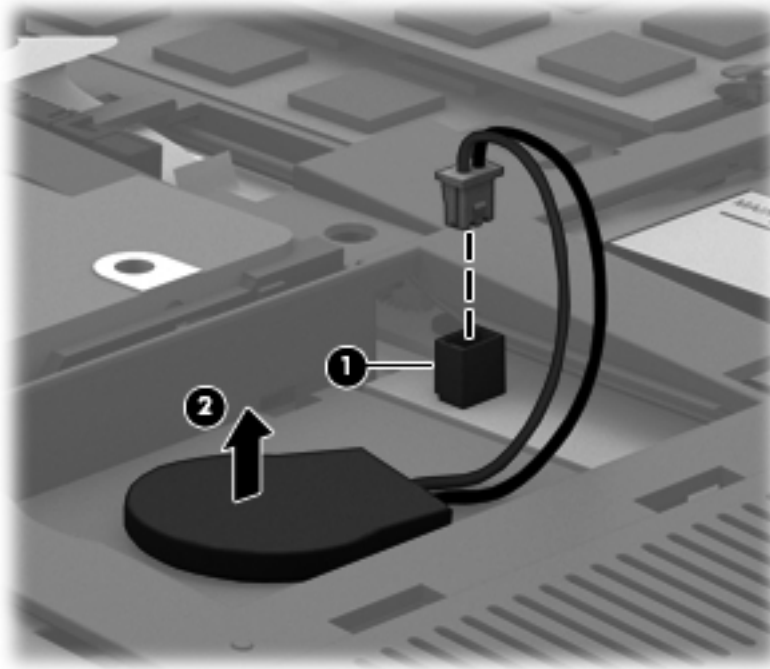

3. Remove the RTC battery.

 **NOTE:** Step 4 applies only to computer models equipped with an Intel processor.

4. Use a thin, non-conductive tool **(1)** to remove the disc cell RTC battery **(2)** from the socket on the system board.

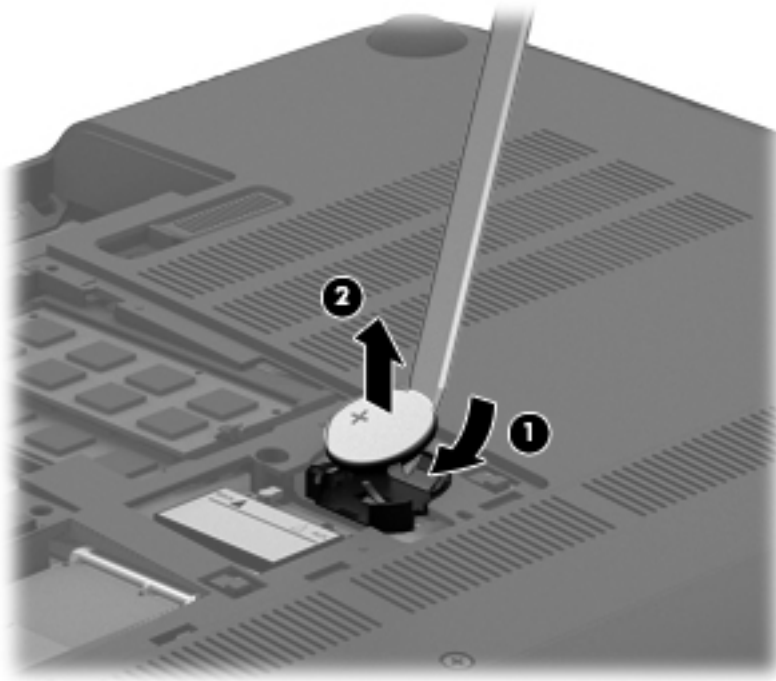

Reverse this procedure to install the RTC battery. When installing the disc cell RTC battery, make sure the “+” sign faces up.

Base enclosure

Description	Spare part number
Base enclosure (includes 4 rubber feet, battery lock latch, battery release latch, and RJ-45 cover)	720534-001

Before removing the base enclosure, follow these steps:

1. Turn off the computer. If you are unsure whether the computer is off or in Hibernation, turn the computer on, and then shut it down through the operating system.
2. Disconnect the power from the computer by unplugging the power cord from the computer.
3. Disconnect all external devices from the computer.
4. Remove the battery (see [Battery on page 43](#)).
5. Remove the solid-state drive (see [Solid-state drive on page 44](#)).
6. Remove the hard drive (see [Hard drive on page 47](#)).

Remove the base enclosure:

1. Remove the front rubber feet **(1)**.

The rubber feet are included in the Rubber Kit, spare part number 720559-001.

2. Remove the seven Phillips PM2.5×5.5 screws **(2)** in the that secure the base enclosure to the computer.

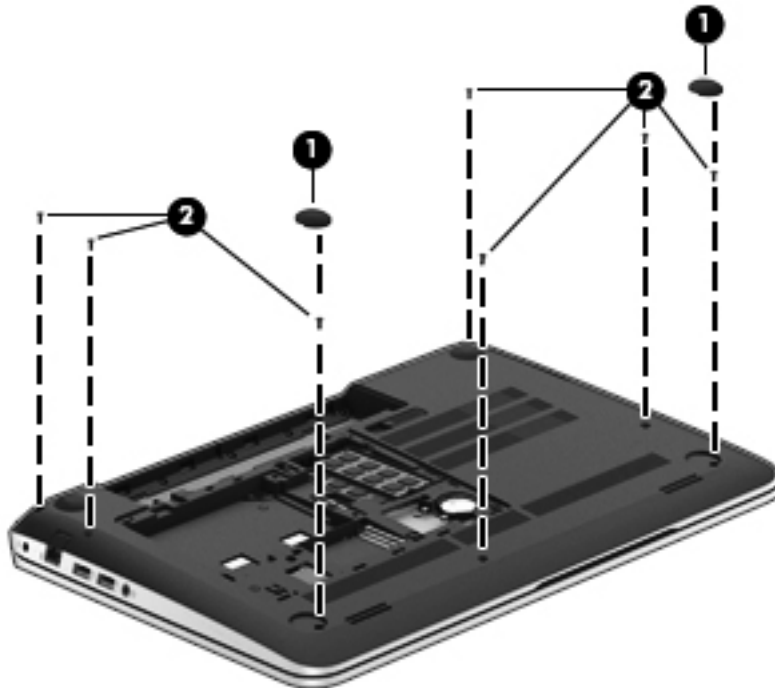

3. Remove the following screws:

(1) Two Phillips PM2.5×4.5 screws under the front edge of the service cover

(2) Three Phillips PM2.5×3.0 screws in the hard drive bay

(3) Seven Phillips PM1.5×2.0 screws in the battery bay

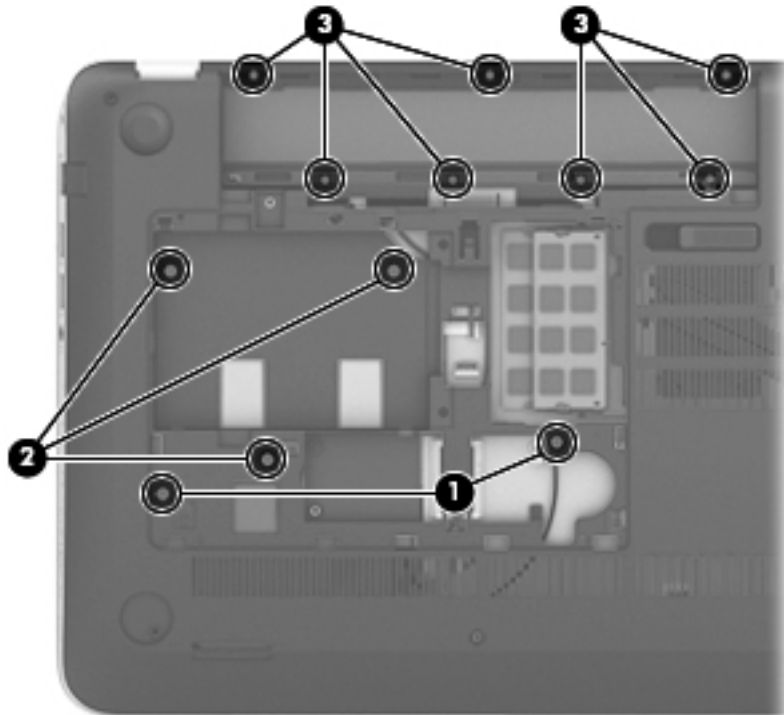

4. Remove the base enclosure.

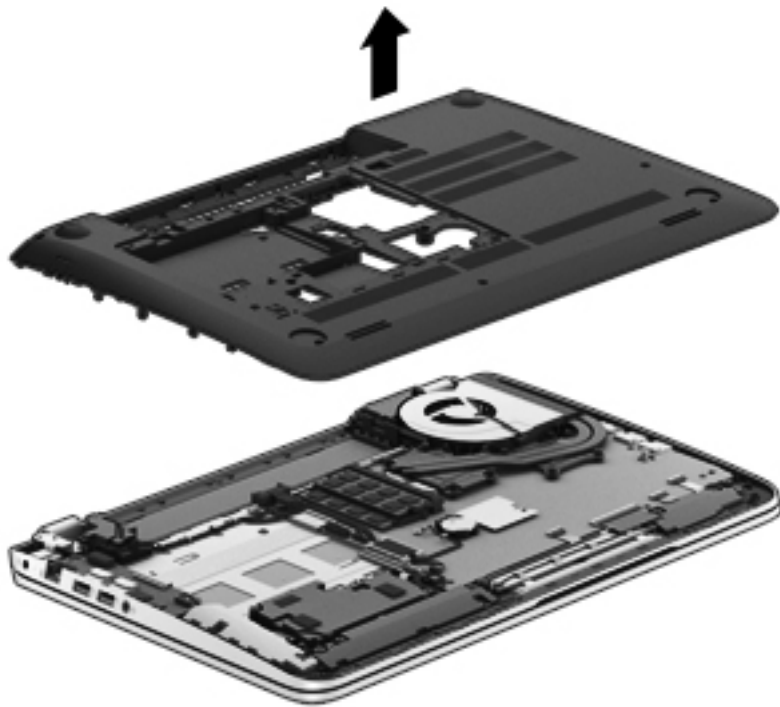

Reverse this procedure to install the base enclosure.

Display assembly

 **NOTE:** The TouchScreen display assembly is spared only at the component level. The non-TouchScreen display assembly is spared at both the component and the subcomponent level. For more display assembly spare part information, see the individual removal subsections.

Description	Spare part number
15.6-in, BrightView, FHD, LED, TouchScreen display assembly	720550-001
15.6-in, BrightView, HD, LED, TouchScreen display assembly	720549-001
15.6-in, BrightView, FHD, LED, non-TouchScreen display assembly	720552-001
15.6-in, BrightView, HD, LED, non-TouchScreen display assembly	720551-001

To remove the display assembly and access the display assembly subcomponents, follow these steps:

1. Turn off the computer. If you are unsure whether the computer is off or in Hibernation, turn the computer on, and then shut it down through the operating system.
2. Disconnect the power from the computer by unplugging the power cord from the computer.

3. Disconnect all external devices from the computer.
4. Remove the battery (see [Battery on page 43](#)), and then remove the following components:
 - a. Solid-state drive (see [Solid-state drive on page 44](#))
 - b. Hard drive (see [Hard drive on page 47](#))
 - c. Base enclosure (see [Base enclosure on page 55](#))

Remove the display assembly:

1. Release the wireless antenna cables from the clips built into the left rear speaker **(1)**, connector board **(2)**, and top cover **(3)**.
2. Release the wireless antenna cables from the routing channel **(4)** between the subwoofer and left front speaker.
3. Disconnect the display panel cable **(5)** and the webcam/microphone module cable **(6)** from the system board.
4. Release the display panel cable and the webcam/microphone module cable from the clips and routing channel built into the right rear speaker **(7)**.

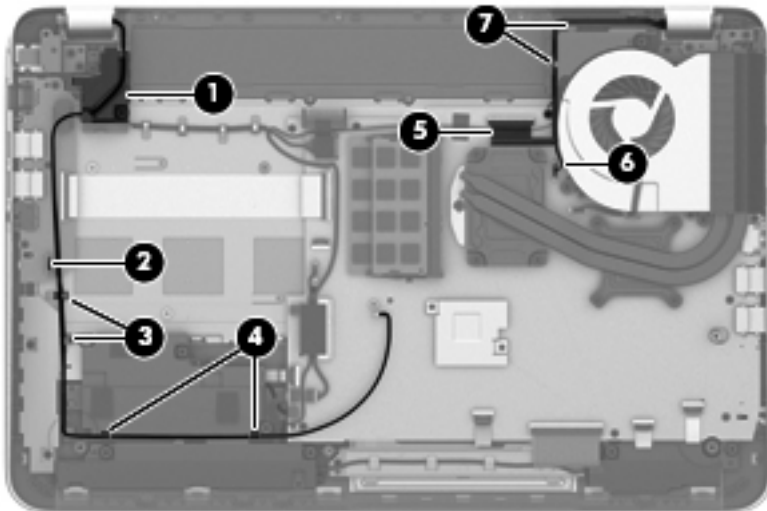

5. Remove the following screws that secure the display assembly to the top cover:
- (1) Three Phillips PM2.5×4.5 screws (two on the left hinge, one on the right hinge)
 - (2) One Phillips PM2.5×6.5 screw on the right hinge
 - (3) One Phillips PM2.0×2.5 screw securing the ground loop on the right hinge

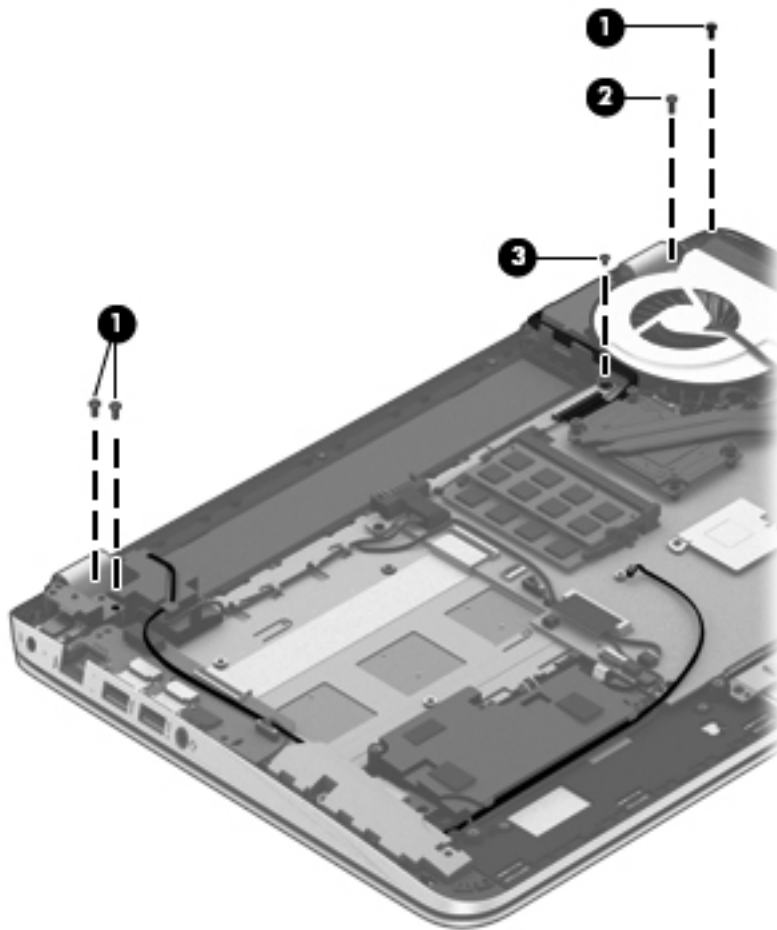

6. Open the display hinges as far as they will open (1).

7. Remove the display assembly **(2)** from the computer.

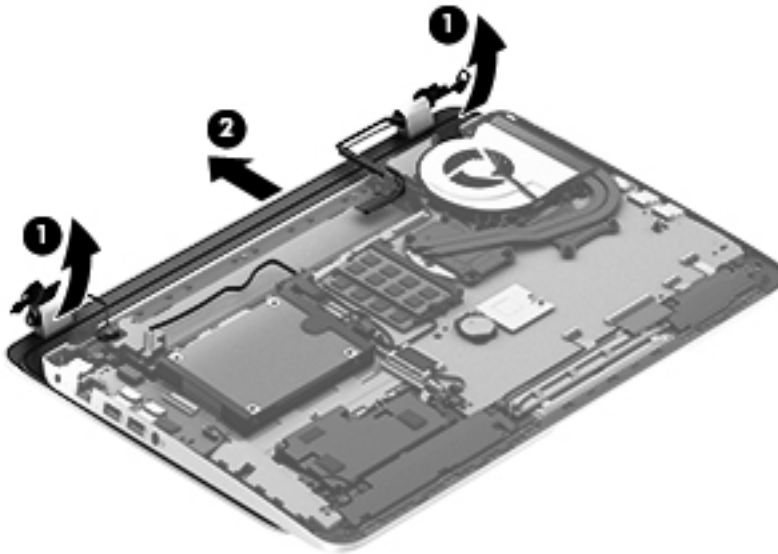

8. If it is necessary to replace the display bezel or any of the display assembly subcomponents:

- a. Remove the two screw covers **(1)** and the four Phillips PM2.5×3.2 broad head screws **(2)** that secure the display bezel to the display assembly.

The screw covers are available in the Rubber Kit, spare part number 720559-001.

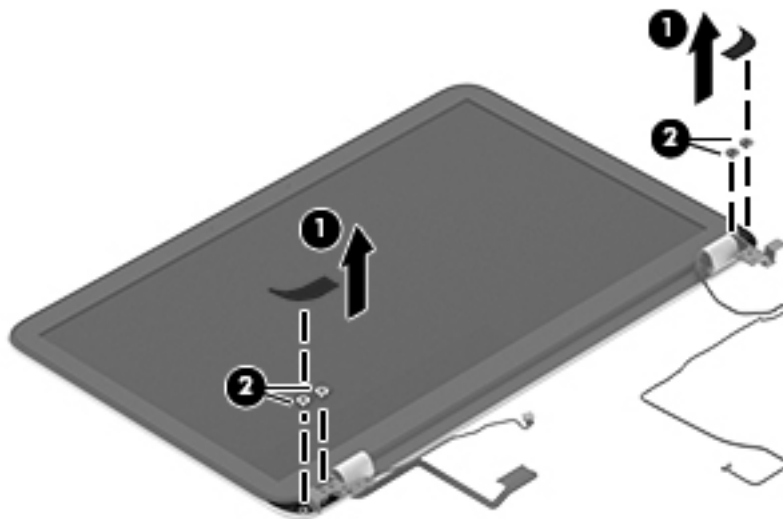

- b. Flex the inside edges of the top edge **(1)**, the left and right sides **(2)**, and the bottom edge **(3)** of the display bezel until the bezel disengages from the display enclosure.

- c. Remove the display bezel **(4)**.

The display bezel is available using spare part number 720535-001.

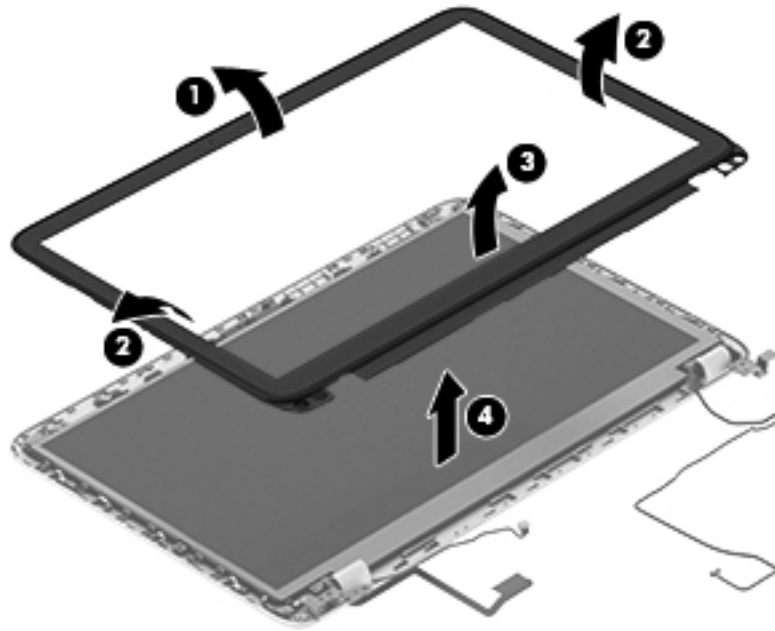

- 9. If it is necessary to replace the display hinge cover:

- a. Remove the four Phillips PM2.0×2.9 screws **(1)** that secure the display hinge covers to the display enclosure.
- b. Remove the display hinge covers **(2)**.

The display hinge covers are available using spare part number 720548-001.

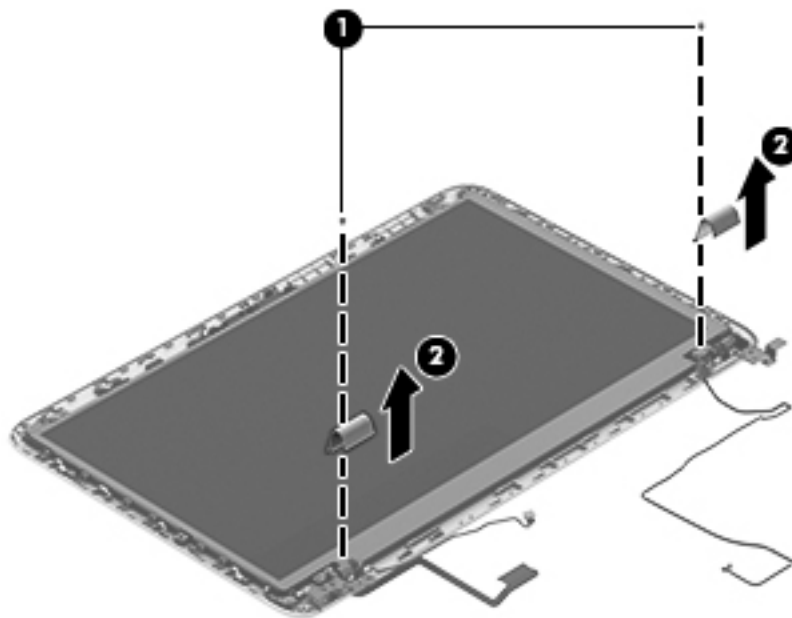

10. If it is necessary to replace the display panel:

- a.** Remove the four Phillips PM2.0×2.9 screws **(1)** that secure the display panel to the display enclosure.
- b.** Lift the display panel **(2)** straight up and remove it from the display enclosure.

The display panel is available using spare part numbers 720557-001 (15.6-in, BrightView, FHD, LED, non-TouchScreen display panel) and 720556-001 (15.6-in, BrightView, HD, LED, non-TouchScreen display panel).

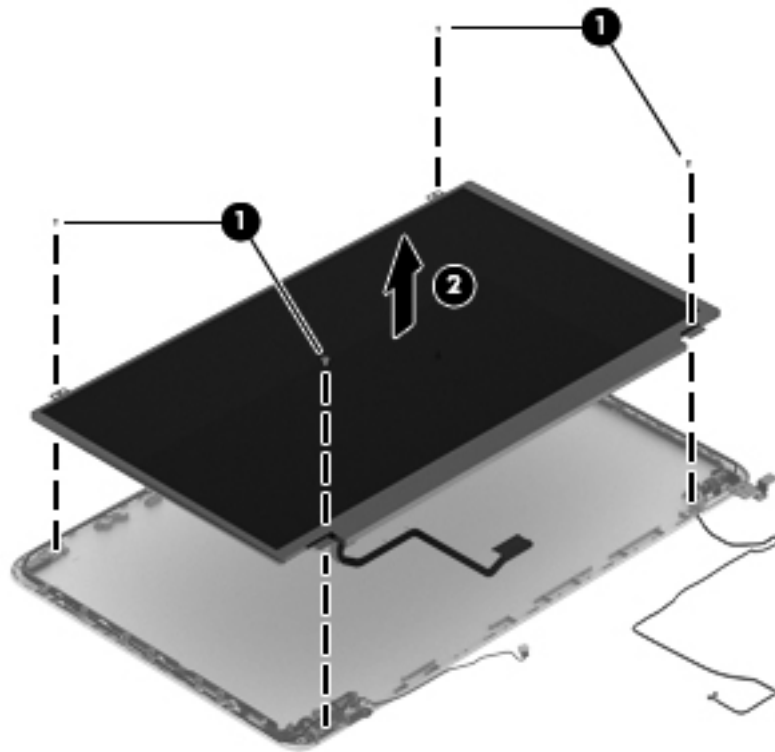

11. If it is necessary to replace the display panel cable:

⚠ CAUTION: Before turning the display panel upside down, make sure the work surface is clear of tools, screws, and any other foreign objects. Failure to follow this caution can result in damage to the display panel.

- a.** Turn the display panel upside down with the bottom edge toward you.

- b. Release the adhesive strip **(1)** that secures the display panel cable to the display panel, and then disconnect the display panel cable **(2)** from the display panel.

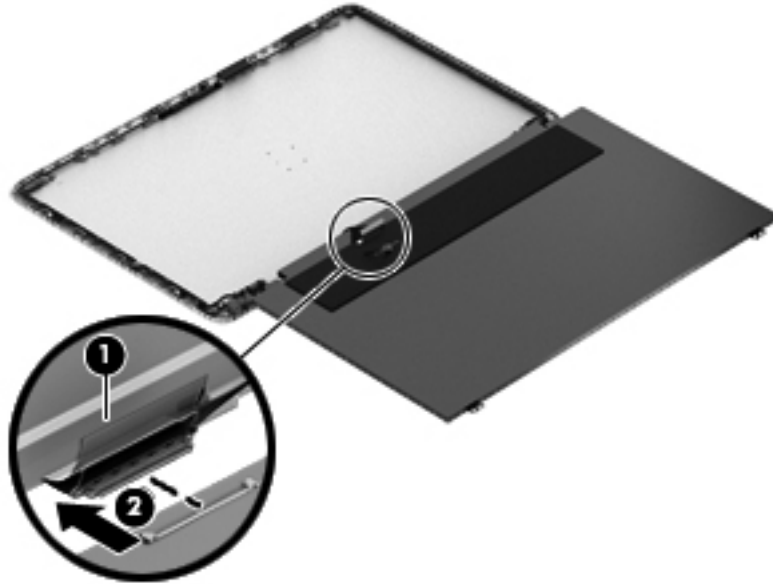

- c. Remove the display panel cable.

The display panel cable is available using spare part number 720536-001.

12. If it is necessary to replace the display hinges and brackets:

- a. Remove the two Phillips PM2.0×2.9 screws **(1)** and the two Phillips PM2.5×3.2 broad head screws **(2)** that secure the display hinges to the display enclosure.
- b. Remove the display hinges **(3)**.

The display hinges are available using spare part number 720548-001.

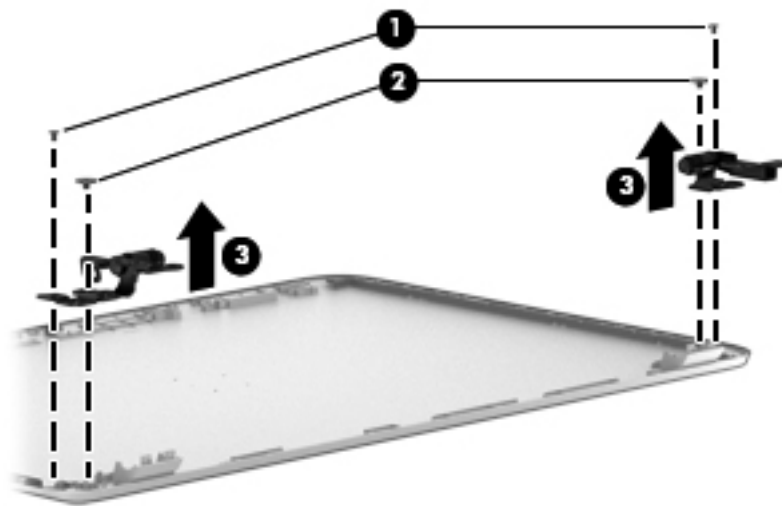

- c. Remove the three Phillips PM2.0×2.9 screws **(1)** that secure the left and right display hinge brackets to the display enclosure.

- d. Remove the left and right display hinge brackets **(2)**.

The display hinge brackets are available using spare part number 720548-001.

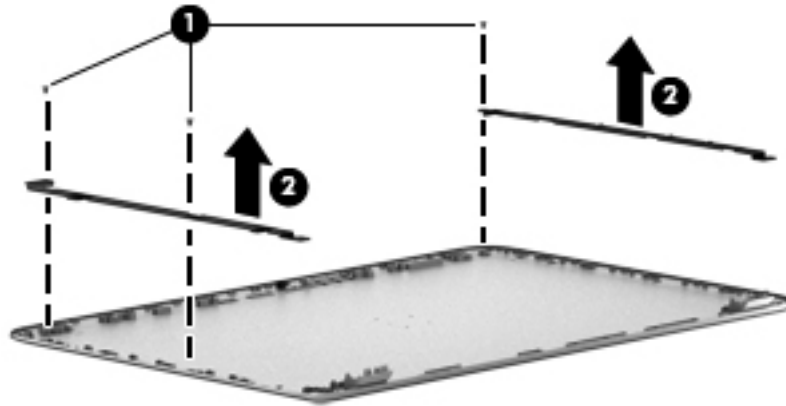

13. If it is necessary to replace the webcam/microphone module:

CAUTION: Handle the webcam/microphone module with caution. This module has a thin profile and is susceptible to damage when not handled carefully.

- a. Release the webcam/microphone module cable **(1)** from the clips and routing channel built into the left and top edges of the display enclosure.
- b. Detach the webcam/microphone module **(2)** from the display enclosure. (The webcam/microphone module is attached to the display enclosure with double-sided adhesive.)

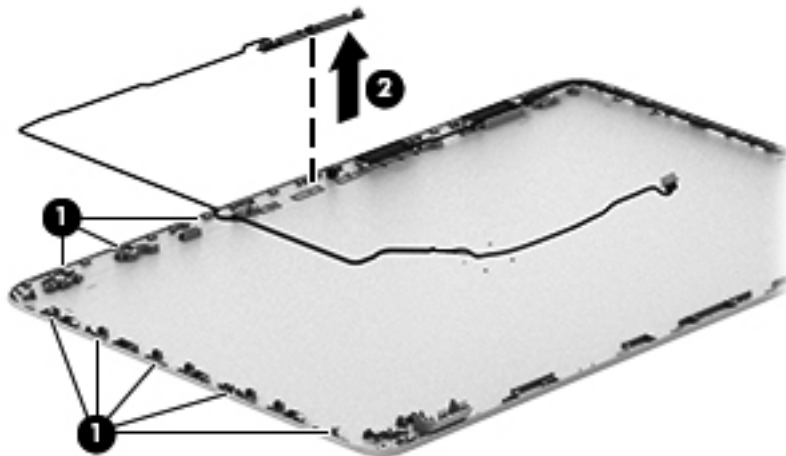

- c. Remove the webcam/microphone module.

The webcam/microphone module is available using spare part number 720273-001, and includes the webcam/microphone module cable.

14. If it is necessary to replace the wireless antenna:

- a. Release the wireless antenna cables from the clips **(1)** and routing channel built into the right edge of the display enclosure.

- b. Detach the wireless antenna transceivers **(2)** from the display enclosure. (The wireless antenna transceivers are attached to the display enclosure with double-sided adhesive.)

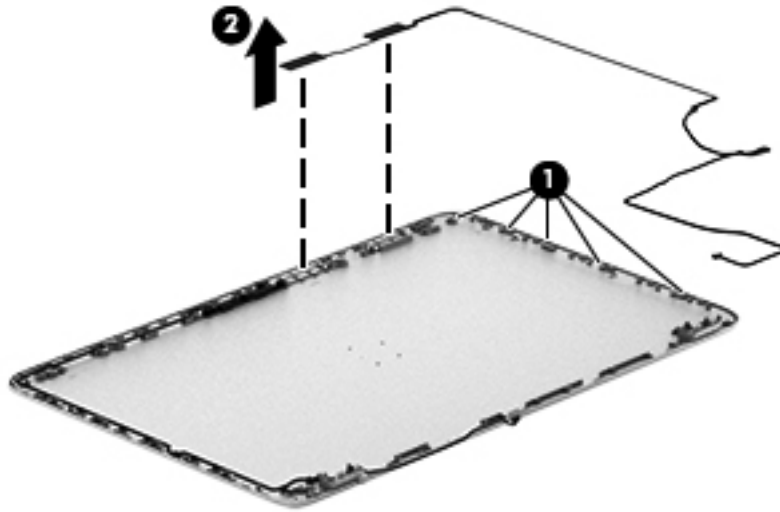

- c. Remove the wireless antenna.

The wireless antenna are available using spare part number 720532-001.

Reverse this procedure to reassemble and install the display assembly.

Fan

Description	Spare part number
Fan (includes cable)	720235-001

Before removing the fan, follow these steps:

1. Turn off the computer. If you are unsure whether the computer is off or in Hibernation, turn the computer on, and then shut it down through the operating system.
2. Disconnect the power from the computer by unplugging the power cord from the computer.
3. Disconnect all external devices from the computer.
4. Remove the battery (see [Battery on page 43](#)), and then remove the following components:
 - a. Solid-state drive (see [Solid-state drive on page 44](#))
 - b. Hard drive (see [Hard drive on page 47](#))
 - c. Base enclosure (see [Base enclosure on page 55](#))
 - d. Display assembly (see [Display assembly on page 57](#))

Remove the fan:

1. Disconnect the fan cable **(1)** from the system board.
2. Remove the two Phillips PM2.5×4.5 screws **(2)** that secure the fan to the top cover.
3. Remove the fan **(3)**.

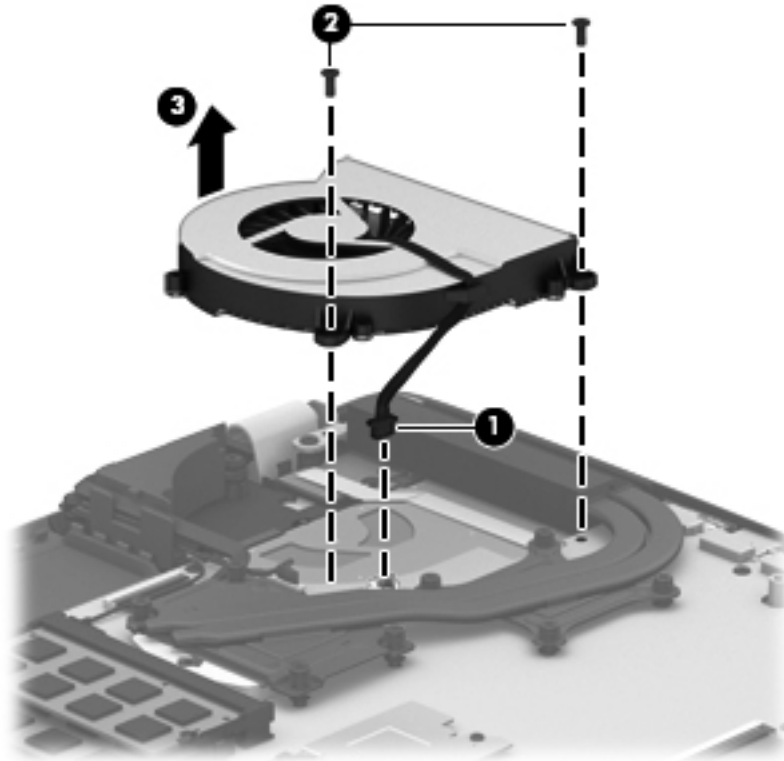

Reverse this procedure to install the fan.

System board

 **NOTE:** The system board spare part kit includes replacement thermal material.

Description	Spare part number
For use only on computer models equipped with an AMD processor, a graphics subsystem with discrete memory, and the Windows 8 Professional operating system	720578-601
For use only on computer models equipped with an AMD processor, a graphics subsystem with discrete memory, and the Windows 8 Standard operating system	720578-501
For use only on computer models equipped with an AMD processor, a graphics subsystem with discrete memory, and the Linux operating system	720578-001
For use only on computer models equipped with an AMD processor, a graphics subsystem with UMA memory, and the Windows 8 Professional operating system	720577-601
For use only on computer models equipped with an AMD processor, a graphics subsystem with UMA memory, and the Windows 8 Standard operating system	720577-501

Description	Spare part number
For use only on computer models equipped with an AMD processor, a graphics subsystem with UMA memory, and the Linux operating system	720577-001
For use only on computer models equipped with the Intel HM87 chipset, the GeForce 750M graphics subsystem, and the Windows 8 Professional operating system	720569-601
For use only on computer models equipped with the Intel HM87 chipset, the GeForce 750M graphics subsystem, and the Windows 8 Standard operating system	720569-501
For use only on computer models equipped with the Intel HM87 chipset, the GeForce 750M graphics subsystem, and the Linux operating system	720569-001
For use only on computer models equipped with the Intel HM87 chipset, the GeForce 740M graphics subsystem, and the Windows 8 Professional operating system	720566-601
For use only on computer models equipped with the Intel HM87 chipset, the GeForce 740M graphics subsystem, and the Windows 8 Standard operating system	720566-501
For use only on computer models equipped with the Intel HM87 chipset, the GeForce 740M graphics subsystem, and the Linux operating system	720566-001
For use only on computer models equipped with the Intel HM87 chipset, a graphics subsystem with UMA memory, and the Windows 8 Professional operating system	720565-601
For use only on computer models equipped with the Intel HM87 chipset, a graphics subsystem with UMA memory, and the Windows 8 Standard operating system	720565-501
For use only on computer models equipped with the Intel HM87 chipset, a graphics subsystem with UMA memory, and the Linux operating system	720565-001
For use only on computer models equipped with the Intel HM77 chipset, the GeForce 740M graphics subsystem, and the Windows 8 Professional operating system	720567-601
For use only on computer models equipped with the Intel HM77 chipset, the GeForce 740M graphics subsystem, and the Windows 8 Standard operating system	720567-501
For use only on computer models equipped with the Intel HM77 chipset, the GeForce 740M graphics subsystem, and the Linux operating system	720567-001
For use only on computer models equipped with the Intel HM77 chipset, a graphics subsystem with UMA memory, and the Windows 8 Professional operating system	720568-601
For use only on computer models equipped with the Intel HM77 chipset, a graphics subsystem with UMA memory, and the Windows 8 Standard operating system	720568-501
For use only on computer models equipped with the Intel HM77 chipset, a graphics subsystem with UMA memory, and the Linux operating system	720568-001

Before removing the system board, follow these steps:

- 1.** Turn off the computer. If you are unsure whether the computer is off or in Hibernation, turn the computer on, and then shut it down through the operating system.
- 2.** Disconnect the power from the computer by unplugging the power cord from the computer.

3. Disconnect all external devices from the computer.
4. Remove the battery (see [Battery on page 43](#)), and then remove the following components:
 - a. Solid-state drive (see [Solid-state drive on page 44](#))
 - b. Hard drive (see [Hard drive on page 47](#))
 - c. Base enclosure (see [Base enclosure on page 55](#))
 - d. Display assembly (see [Display assembly on page 57](#))
 - e. Fan (see [Fan on page 65](#))

 **NOTE:** When replacing the system board, be sure that the following components are removed from the defective system board and installed on the replacement system board:

- Memory module (see [Memory module on page 49](#))
- Heat sink (see [Heat sink on page 72](#))
- Processor (see [Processor on page 77](#))

Remove the system board:

1. Disconnect the following cables from the system board:
 - (1) Fingerprint reader board ribbon cable
 - (2) Connector board cable
 - (3) Connector board ribbon cable
 - (4) Power connector cable
 - (5) Display panel ribbon cable
 - (6) Webcam/microphone module cable
 - (7) Wireless antenna cables

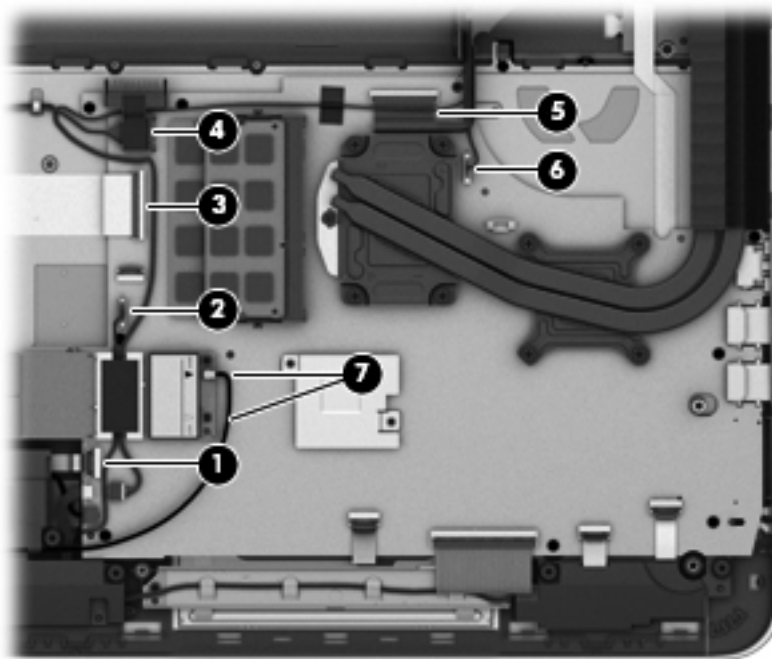

2. Disconnect the following cables from the system board:

- (1)** Rear speaker cable
- (2)** Subwoofer cable
- (3)** Front speaker cable
- (4)** TouchPad ribbon cable
- (5)** Keyboard ribbon cable
- (6)** Power button board ribbon cable

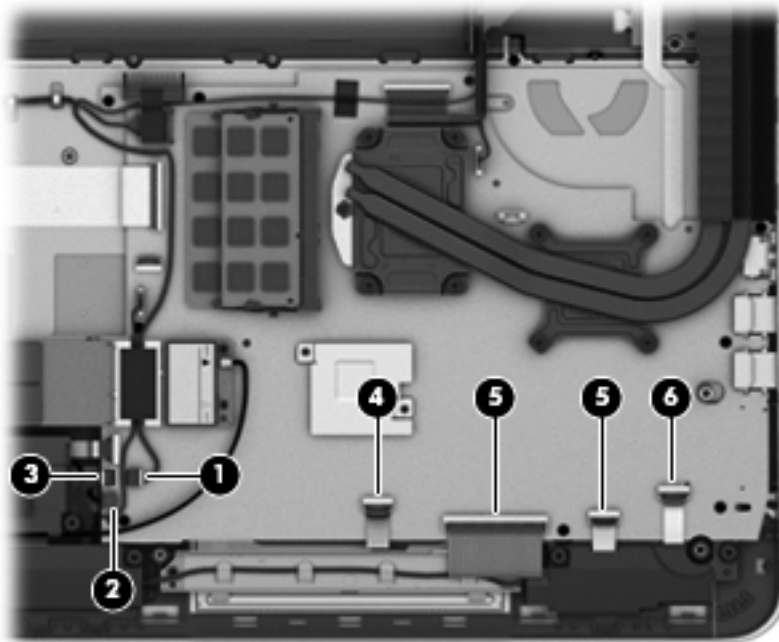

3. Remove the nine Phillips PM2.0×2.9 screws that secure the system board to the top cover.

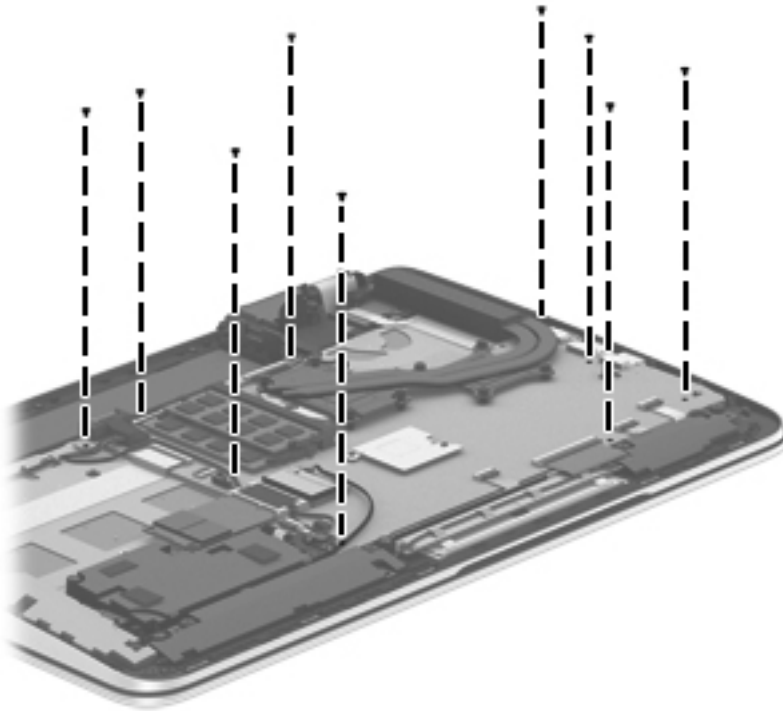

4. Lift the left side of the system board **(1)** until it rests at an angle.
5. Remove the system board **(2)** by sliding it up and to the left an angle.



Reverse this procedure to install the system board.

Heat sink



NOTE: The heat sink spare part kit includes replacement thermal material.

Description	Spare part number
For use only on computer models equipped with an AMD processor	720576-001
For use only on computer models equipped with the Intel HM87 chipset and a GeForce 750M graphics subsystem	720542-001
For use only on computer models equipped with the Intel HM87 chipset and a GeForce 740M graphics subsystem	722389-001
For use only on computer models equipped with the Intel HM87 chipset and a graphics subsystem with UMA memory	720541-001
For use only on computer models equipped with the Intel HM77 chipset and a graphics subsystem with discrete memory	720540-001
For use only on computer models equipped with the Intel HM77 chipset and a graphics subsystem with UMA memory	720539-001

Before removing the heat sink, follow these steps:

1. Turn off the computer. If you are unsure whether the computer is off or in Hibernation, turn the computer on, and then shut it down through the operating system.
2. Disconnect the power from the computer by unplugging the power cord from the computer.
3. Disconnect all external devices from the computer.
4. Remove the battery (see [Battery on page 43](#)), and then remove the following components:
 - a. Solid-state drive (see [Solid-state drive on page 44](#))
 - b. Hard drive (see [Hard drive on page 47](#))
 - c. Base enclosure (see [Base enclosure on page 55](#))
 - d. Display assembly (see [Display assembly on page 57](#))
 - e. Fan (see [Fan on page 65](#))
 - f. System board (see [System board on page 66](#))

Remove the heat sink:

1. Turn the system board upside down, with the front toward you.





NOTE: Steps 2 and 3 apply to computer models equipped with an AMD processor and a graphics subsystem with discrete memory.

2. Following the 1 through 7 sequence stamped into the heat sink, loosen the four Phillips PM2.0×11.0 captive screws **(2)** and the three Phillips PM2.0×7.5 captive screws **(3)** that secure the heat sink to the system board.

3. Remove the heat sink **(4)**.

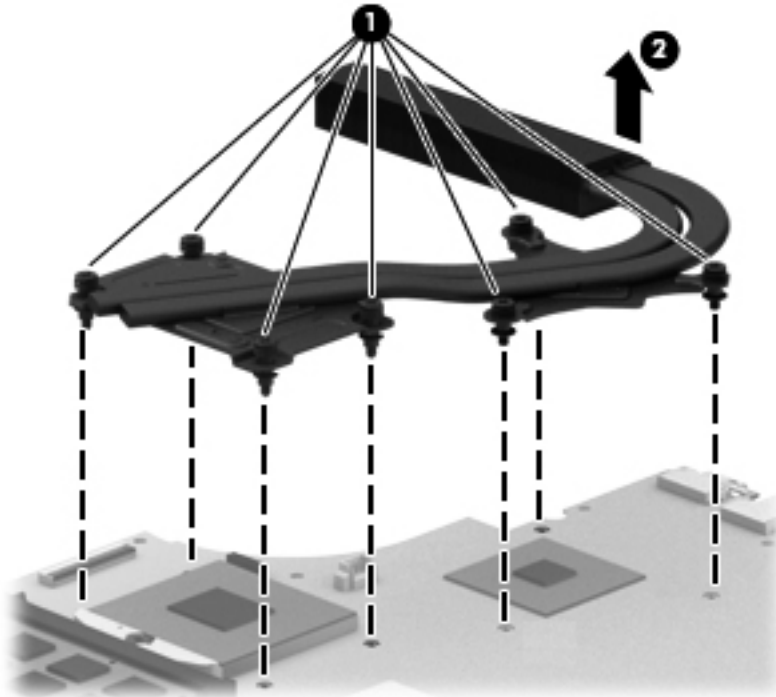
 **NOTE:** Due to the adhesive quality of the thermal material located between the heat sink and the system board components, it may be necessary to move the heat sink from side to side to detach it.





 **NOTE:** Steps 4 and 5 apply to computer models equipped with an Intel processor and a graphics subsystem with discrete memory.

4. Following the 1 through 8 sequence stamped into the heat sink, loosen the eight Phillips PM2.0×1 1.0 captive screws **(1)** that secure the heat sink to the system board.

5. Remove the heat sink **(2)**.

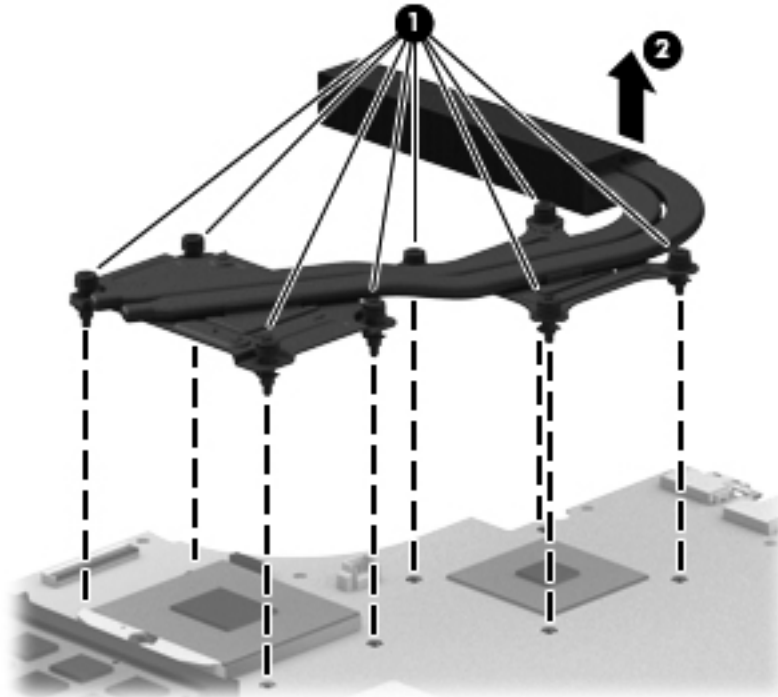
 **NOTE:** Due to the adhesive quality of the thermal material located between the heat sink and the system board components, it may be necessary to move the heat sink from side to side to detach it.





 **NOTE:** Steps 6 and 7 apply to computer models equipped with a graphics subsystem with UMA memory.

6. Following the 1 through 4 sequence stamped into the heat sink, loosen the four Phillips PM2.0×11.0 captive screws **(1)** that secure the heat sink to the system board.

7. Remove the heat sink **(2)**.

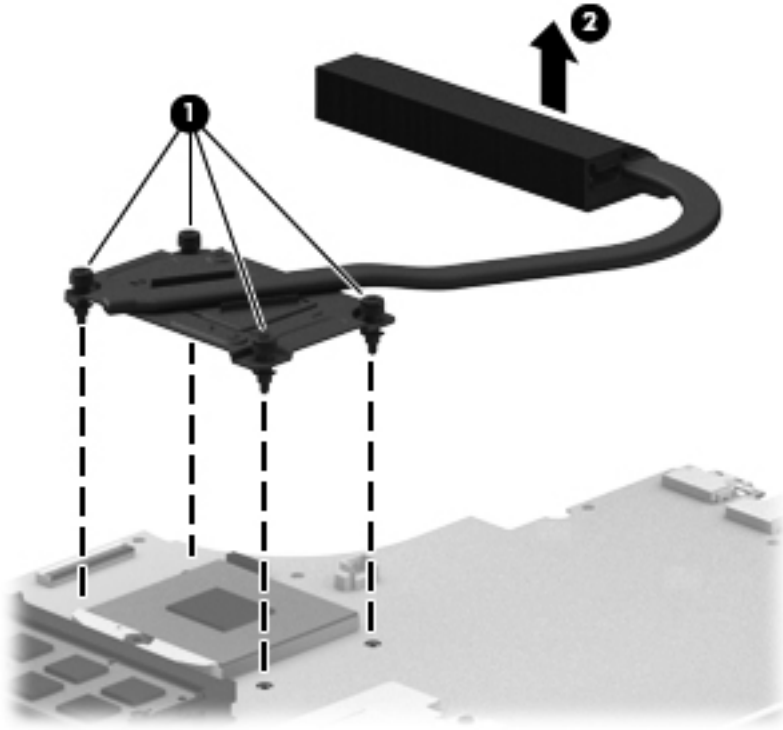
 **NOTE:** Due to the adhesive quality of the thermal material located between the heat sink and the system board components, it may be necessary to move the heat sink from side to side to detach it.



 **NOTE:** The thermal material must be thoroughly cleaned from the surfaces of the heat sink and the system board components each time the heat sink is removed. Replacement thermal material is included with the heat sink, processor, and system board spare part kits.

- Thermal paste is used on the processor **(1)** and the heat sink section **(2)** that services it
- Thermal paste is used on the graphics subsystem chip **(3)** and the heat sink section **(4)** that services it

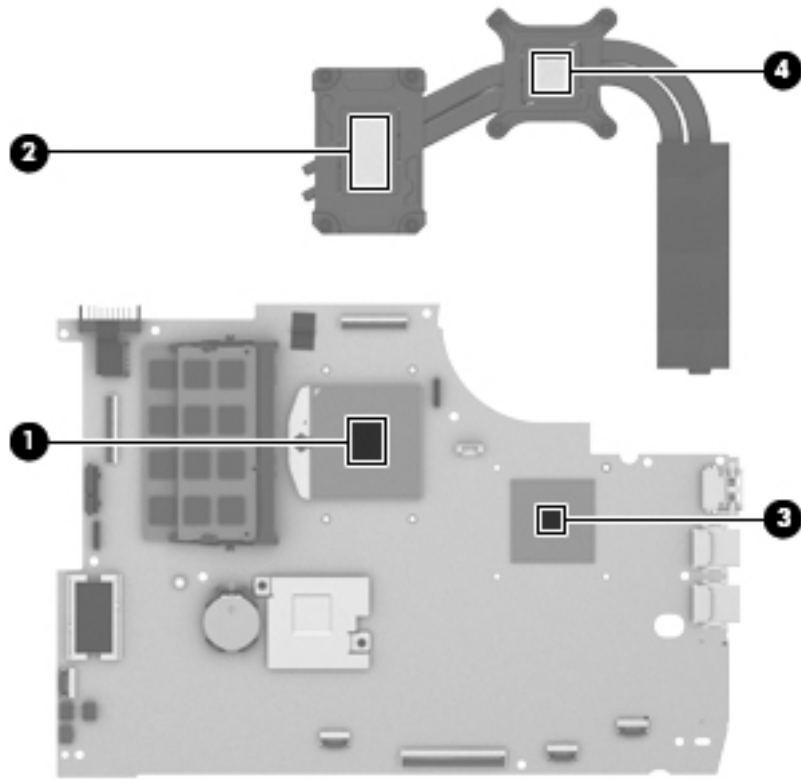
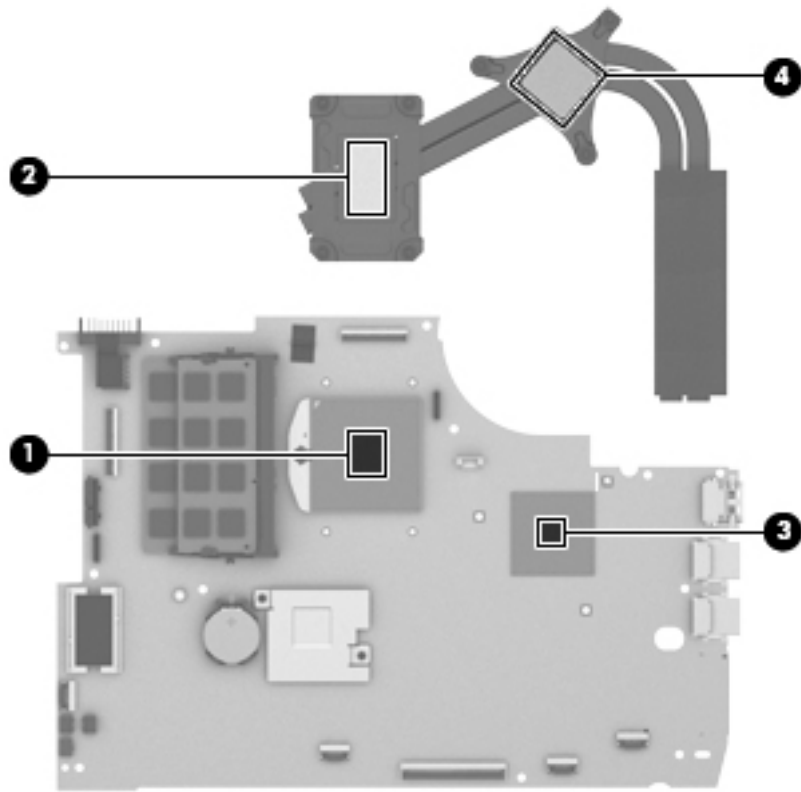

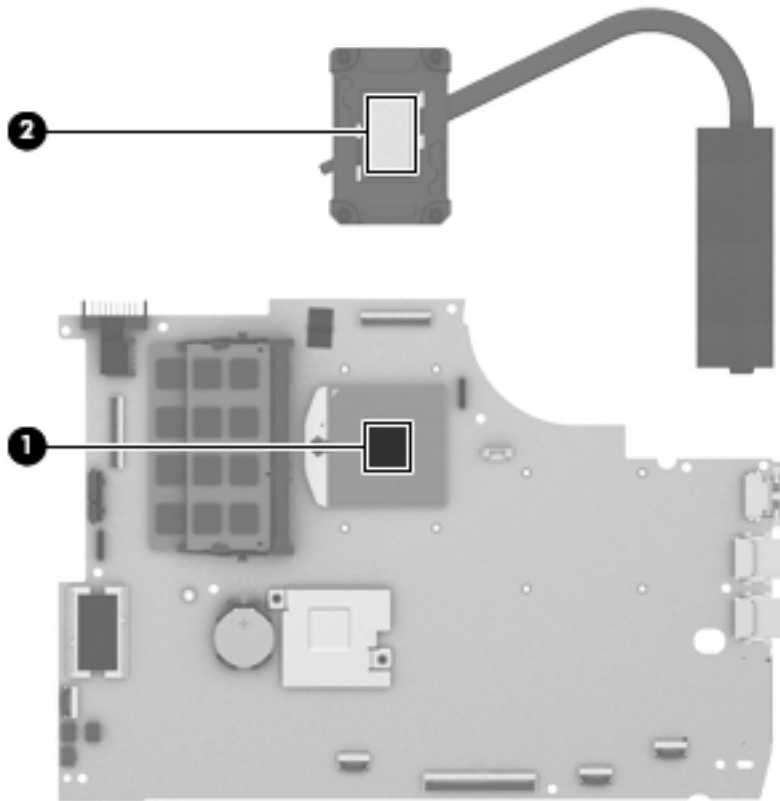

Reverse this procedure to install the heat sink.

Processor

 **NOTE:** The processor spare part kit includes replacement thermal material.

Description	Spare part number
AMD A10-5750M 2.50-GHz processor (turbo up to 3.50-GHz; 1600-MHz FSB, 4.0- MB L2 cache, DDR3, quad core, 35 W)	713548-001
AMD A8-5550M 2.10-GHz processor (turbo up to 3.10-GHz; 1600-MHz FSB, 4.0- MB L2 cache, DDR3, quad core, 35 W)	713551-001
AMD A6-5350M 2.90-GHz processor (turbo up to 3.50-GHz; 1600-MHz FSB, 1.0- MB L2 cache, DDR3, dual core, 35 W)	713550-001
AMD A4-5150M 2.70-GHz processor (turbo up to 3.30-GHz; 1600-MHz FSB, 1.0- MB L2 cache, DDR3, dual core, 35 W)	713549-001
Intel Quad Core i7-4900MQ 2.80-GHz processor (SC turbo up to 3.80-GHz; 1600-MHz FSB, 8.0-MB L3 cache, 47 W)	723523-001
Intel Quad Core i7-4800MQ 2.70-GHz processor (SC turbo up to 3.70-GHz; 1600-MHz FSB, 6.0-MB L3 cache, 47 W)	723524-001
Intel Quad Core i7-4702MQ 2.20-GHz processor (SC turbo up to 3.20-GHz; 1600-MHz FSB, 6.0-MB L3 cache, 37 W)	723522-001

Description	Spare part number
Intel Quad Core i7-4700MQ 2.40-GHz processor (SC turbo up to 3.40-GHz; 1600-MHz FSB, 6.0-MB L3 cache, 47 W)	723521-001
Intel Dual Core i5-3380M 2.90-GHz processor (SC turbo up to 3.60-GHz; 1600-MHz FSB; 3.0-MB L3 cache, 35 W)	708762-001
Intel Dual Core i5-3230M 2.60-GHz processor (SC turbo up to 3.20-GHz; 1600-MHz FSB, 3.0-MB L3 cache, 35 W)	711903-001
Intel Dual Core i3-3130M 2.60-GHz processor (1600-MHz FSB, 3.0-MB L3 cache, 35 W)	713163-001
Intel Dual Core i5-3120M 2.40-GHz processor (1600-MHz FSB, 3.0-MB L3 cache, 35 W)	700627-001

Before removing the processor, follow these steps:

1. Turn off the computer. If you are unsure whether the computer is off or in Hibernation, turn the computer on, and then shut it down through the operating system.
2. Disconnect the power from the computer by unplugging the power cord from the computer.
3. Disconnect all external devices from the computer.
4. Remove the battery (see [Battery on page 43](#)), and then remove the following components:
 - a. Solid-state drive (see [Solid-state drive on page 44](#))
 - b. Hard drive (see [Hard drive on page 47](#))
 - c. Base enclosure (see [Base enclosure on page 55](#))
 - d. Display assembly (see [Display assembly on page 57](#))
 - e. Fan (see [Fan on page 65](#))
 - f. System board (see [System board on page 66](#))
 - g. Heat sink (see [Heat sink on page 72](#))

Remove the processor:

1. Use a flat-bladed screw driver **(1)** to turn the processor locking screw one-half turn counterclockwise **(2)**, until you hear a click.

2. Lift the processor **(3)** straight up, and remove it.

 **NOTE:** The gold triangle **(4)** on the processor must be aligned with the triangle icon embossed on the processor socket when you install the processor.

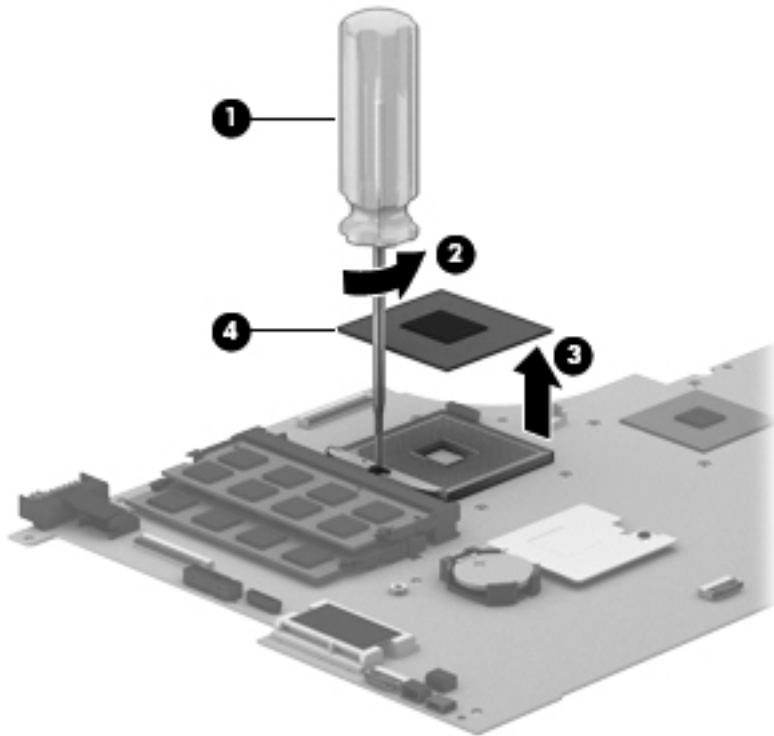

Reverse this procedure to install the processor.

Connector board

Description	Spare part number
For use only on computer models equipped with an AMD processor	720579-001
For use only on computer models equipped with an Intel processor and a graphics subsystem with discrete memory	723372-001
For use only on computer models equipped with an Intel processor and a graphics subsystem with UMA memory	720554-001

Before removing the connector board, follow these steps:

1. Turn off the computer. If you are unsure whether the computer is off or in Hibernation, turn the computer on, and then shut it down through the operating system.
2. Disconnect the power from the computer by unplugging the power cord from the computer.
3. Disconnect all external devices from the computer.
4. Remove the battery (see [Battery on page 43](#)), and then remove the following components:
 - a. Solid-state drive (see [Solid-state drive on page 44](#))
 - b. Hard drive (see [Hard drive on page 47](#))
 - c. Base enclosure (see [Base enclosure on page 55](#))

Remove the connector board:

1. Disconnect the connector board cable **(1)** from the system board.
2. Release the connector board cable from the routing clips **(2)** built into the top cover and routing channel **(3)** between the subwoofer and left front speaker.
3. Release the ZIF connector **(4)** to which the connector board ribbon cable is attached, and then disconnect the connector board ribbon cable from the system board.

4. Detach the connector board ribbon cable **(5)** from the base enclosure. (The connector board ribbon cable is attached to the top cover with double-sided tape.)

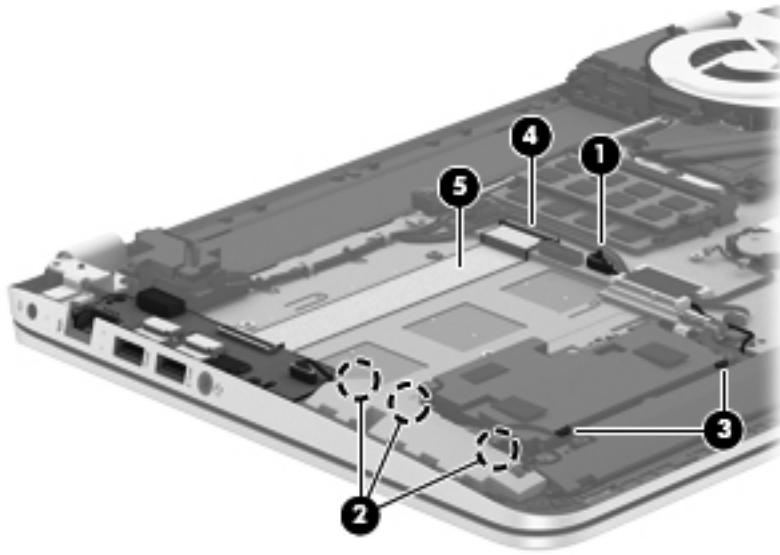

5. Remove the three Phillips PM2.0x2.9 screws **(1)** that secure the connector board to the top cover.
6. Lift the right side of the connector board **(2)** until it rests at an angle.
7. Remove the connector board **(3)** by sliding it up and to the right at an angle.

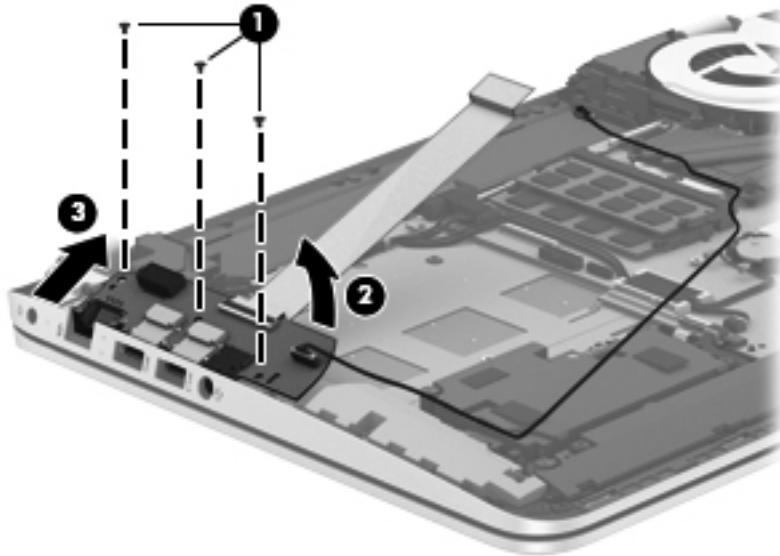

Reverse this procedure to install the connector board.

Power connector cable

Description	Spare part number
For use on all computer models equipped with a graphics subsystem with UMA memory	720537-001
For use only on computer models equipped with an Intel processor and a graphics subsystem with discrete memory	720538-001

Before removing the power connector cable, follow these steps:

1. Turn off the computer. If you are unsure whether the computer is off or in Hibernation, turn the computer on, and then shut it down through the operating system.
2. Disconnect the power from the computer by unplugging the power cord from the computer.
3. Disconnect all external devices from the computer.
4. Remove the battery (see [Battery on page 43](#)), and then remove the following components:
 - a. Solid-state drive (see [Solid-state drive on page 44](#))
 - b. Hard drive (see [Hard drive on page 47](#))
 - c. Base enclosure (see [Base enclosure on page 55](#))

Remove the power connector cable:

1. Disconnect the power cable **(1)** from the system board.
2. Release the power connector cable from the clips **(2)** built into the keyboard shield.
3. Release the power connector **(3)** from the clips and mold built into the top cover.

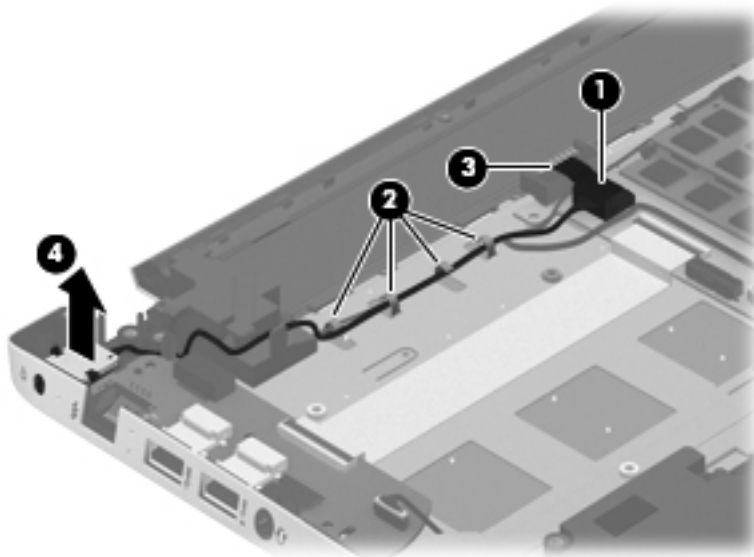

4. Remove the power connector cable.

Reverse this procedure to install the power connector cable.

Subwoofer

Description	Spare part number
Subwoofer (includes cable and 3 isolators)	720563-001

Before removing the subwoofer, follow these steps:

1. Turn off the computer. If you are unsure whether the computer is off or in Hibernation, turn the computer on, and then shut it down through the operating system.
2. Disconnect the power from the computer by unplugging the power cord from the computer.
3. Disconnect all external devices from the computer.
4. Remove the battery (see [Battery on page 43](#)), and then remove the following components:
 - a. Solid-state drive (see [Solid-state drive on page 44](#))
 - b. Hard drive (see [Hard drive on page 47](#))
 - c. Base enclosure (see [Base enclosure on page 55](#))

Remove the subwoofer:

1. Disconnect the subwoofer cable **(1)** from the system board.
2. Remove the three Phillips PM2.5×6.2 screws **(2)** that secure the subwoofer to the top cover.

3. Remove the subwoofer **(3)**.

 **NOTE:** The subwoofer includes three rubber isolators **(4)**. These isolators are crucial to the performance of the subwoofer.

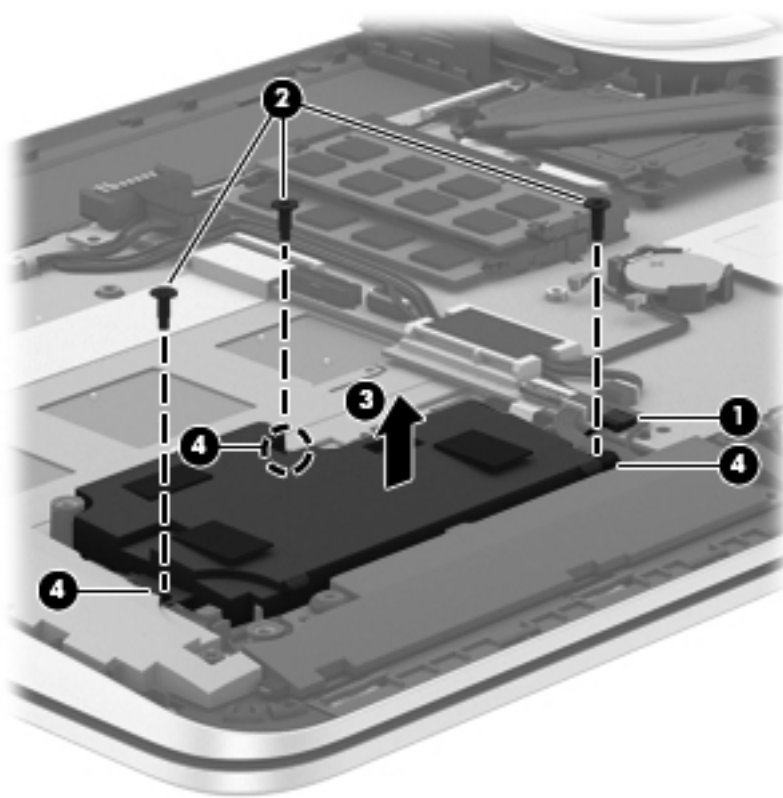

Reverse this procedure to install the subwoofer.

Rear speakers

Description	Spare part number
Rear speakers (include left and right rear speakers, 2 cables, and 4 isolators)	720561-001

Before removing the rear speakers, follow these steps:

1. Turn off the computer. If you are unsure whether the computer is off or in Hibernation, turn the computer on, and then shut it down through the operating system.
2. Disconnect the power from the computer by unplugging the power cord from the computer.
3. Disconnect all external devices from the computer.
4. Remove the battery (see [Battery on page 43](#)), and then remove the following components:
 - a. Solid-state drive (see [Solid-state drive on page 44](#))
 - b. Hard drive (see [Hard drive on page 47](#))
 - c. Base enclosure (see [Base enclosure on page 55](#))

Remove the rear speakers:

1. Disconnect the rear speaker cable **(1)** from the system board.
2. Release the rear speaker cables from the clips **(2)** and routing channel built into the top cover.
3. Remove the four Phillips PM2.5×6.2 screws **(3)** that secure the rear speakers to the top cover.

4. Remove the rear speakers (4).

 **NOTE:** The rear speakers includes four rubber isolators (5). These isolators are crucial to the performance of the rear speakers.

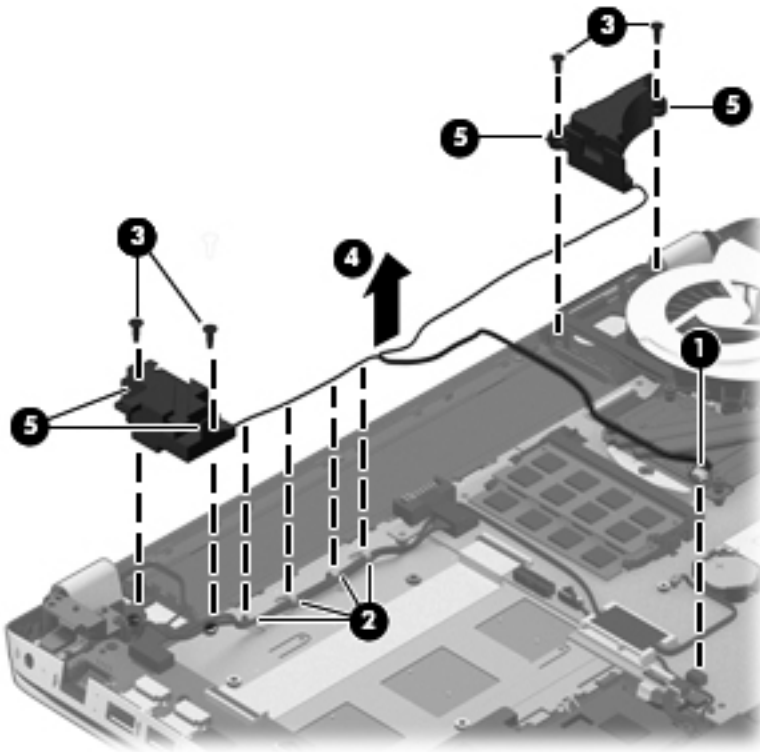

Reverse this procedure to install the rear speakers.

Fingerprint reader board

Description	Spare part number
Fingerprint reader board (includes bracket and cable)	720543-001

Before removing the fingerprint reader board, follow these steps:

1. Turn off the computer. If you are unsure whether the computer is off or in Hibernation, turn the computer on, and then shut it down through the operating system.
2. Disconnect the power from the computer by unplugging the power cord from the computer.
3. Disconnect all external devices from the computer.
4. Remove the battery (see [Battery on page 43](#)), and then remove the following components:
 - a. Solid-state drive (see [Solid-state drive on page 44](#))
 - b. Hard drive (see [Hard drive on page 47](#))
 - c. Base enclosure (see [Base enclosure on page 55](#))
 - d. Base enclosure (see [Base enclosure on page 55](#))
 - e. Subwoofer (see [Subwoofer on page 83](#))

Remove the fingerprint reader board:

1. Release the ZIF connector **(1)** to which the fingerprint reader board ribbon cable is attached, and then disconnect the fingerprint reader board ribbon cable from the system board.
2. Detach the fingerprint reader board ribbon cable **(2)** from the base enclosure. (The fingerprint reader board ribbon cable is attached to the top cover with double-sided tape.)
3. Remove the Phillips PM2.0×2.9 screw **(3)** that secures the fingerprint reader board bracket and board to the top cover.
4. Slide the fingerprint reader board bracket **(4)** to the left, and then lift it straight up to remove it.

5. Remove the fingerprint reader board (5) and cable.

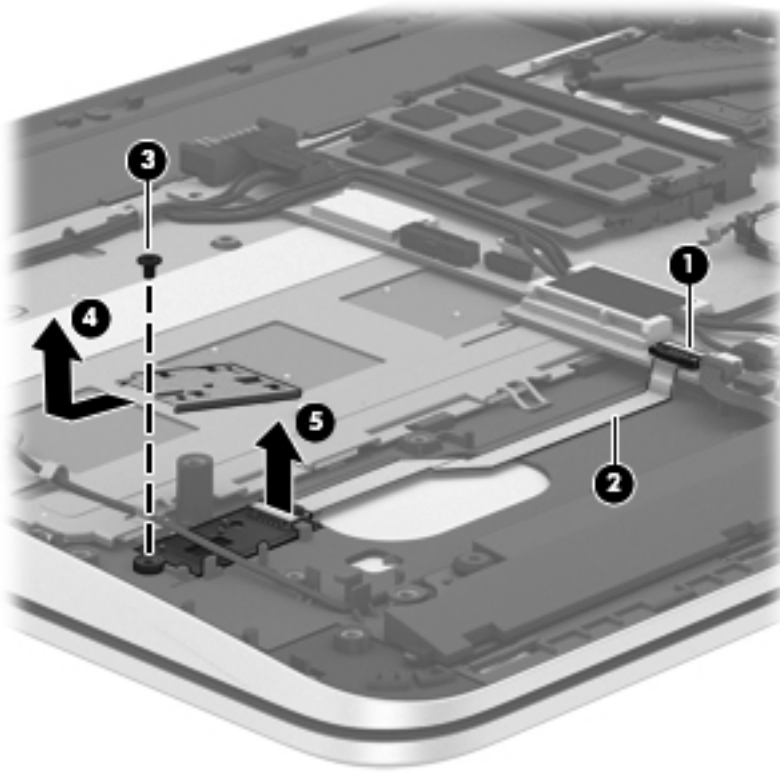

Reverse this procedure to install the fingerprint reader board.

Front speakers

Description	Spare part number
Front speakers (include left and right front speakers, 2 cables, and 4 isolators)	720562-001

Before removing the front speakers, follow these steps:

1. Turn off the computer. If you are unsure whether the computer is off or in Hibernation, turn the computer on, and then shut it down through the operating system.
2. Disconnect the power from the computer by unplugging the power cord from the computer.
3. Disconnect all external devices from the computer.
4. Remove the battery (see [Battery on page 43](#)), and then remove the following components:
 - a. Solid-state drive (see [Solid-state drive on page 44](#))
 - b. Hard drive (see [Hard drive on page 47](#))
 - c. Base enclosure (see [Base enclosure on page 55](#))
 - d. System board (see [System board on page 66](#))

Remove the front speakers:

1. Release the front speaker cables from the clips **(1)** and routing channel built into the TouchPad.
2. Remove the four Phillips PM2.5×6.2 screws **(2)** that secure the front speakers to the top cover.
3. Remove the front speakers **(3)**.

 **NOTE:** The front speakers includes four rubber isolators **(4)**. These isolators are crucial to the performance of the front speakers.

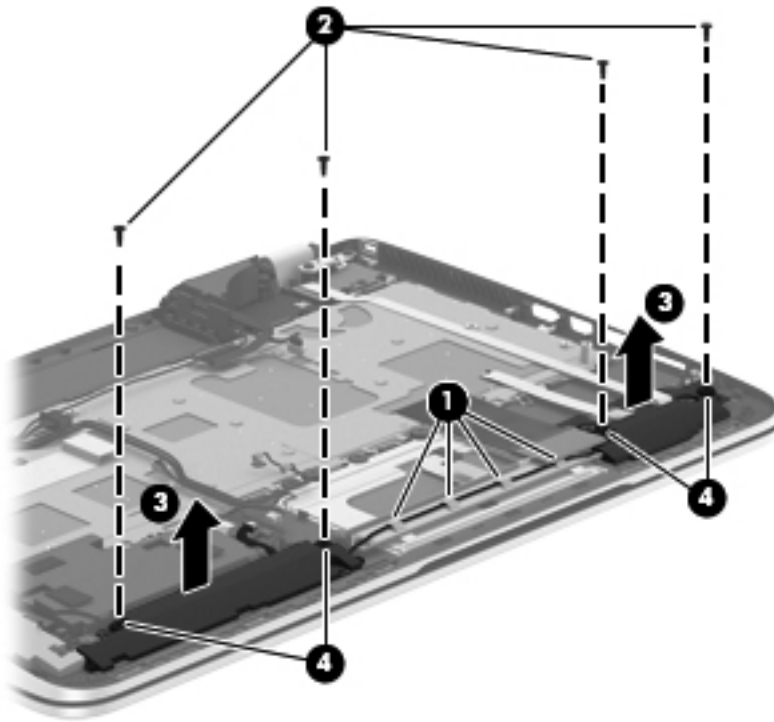

Reverse this procedure to install the front speakers.

TouchPad assembly

Description	Spare part number
TouchPad assembly (includes TouchPad bracket, TouchPad button board, TouchPad, and cables)	722972-001

Before removing the TouchPad, follow these steps:

1. Turn off the computer. If you are unsure whether the computer is off or in Hibernation, turn the computer on, and then shut it down through the operating system.
2. Disconnect the power from the computer by unplugging the power cord from the computer.
3. Disconnect all external devices from the computer.
4. Remove the battery (see [Battery on page 43](#)), and then remove the following components:
 - a. Solid-state drive (see [Solid-state drive on page 44](#))
 - b. Hard drive (see [Hard drive on page 47](#))
 - c. Base enclosure (see [Base enclosure on page 55](#))
 - d. System board (see [System board on page 66](#))
 - e. Front speakers (see [Front speakers on page 88](#))

Remove the TouchPad:

1. Remove the two Phillips PM2.0×2.9 screws **(1)** that secure the TouchPad bracket to the top cover.

2. Remove the TouchPad bracket **(2)**.

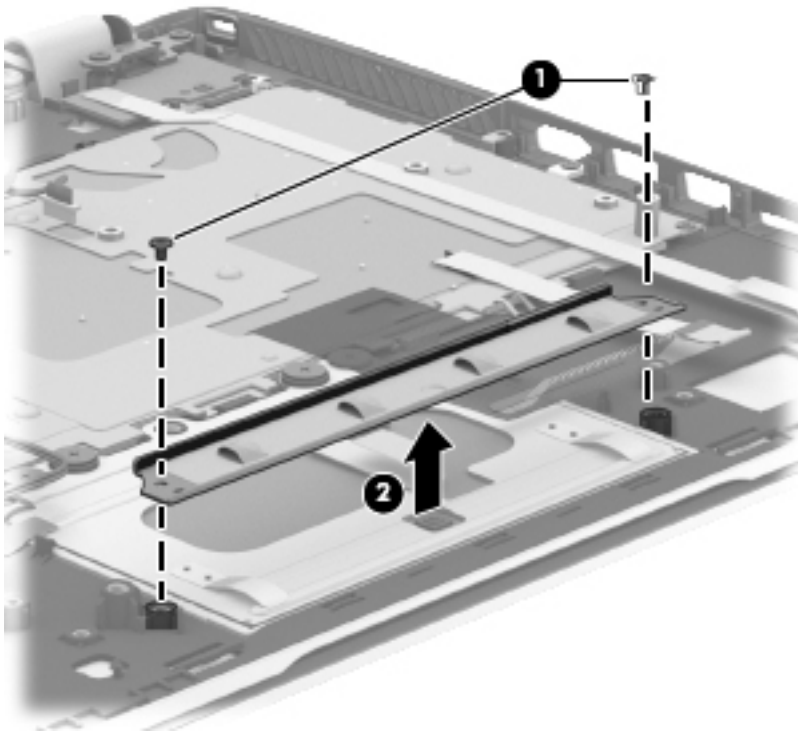

3. Release the two pieces of grounding tape **(1)** that connect the TouchPad to the top cover.
4. Remove the four Phillips PM2.5×2.5 broad head screws **(2)** that secure the TouchPad to the top cover.

 **NOTE:** The second and third screws include two rubber washers **(3)**. These washers are crucial to the performance of the TouchPad.

5. Lift the rear edge of the TouchPad **(4)** until it rests at an angle.

6. Slide the TouchPad **(5)** toward the back of the top cover, and then lift the TouchPad straight up and remove it.

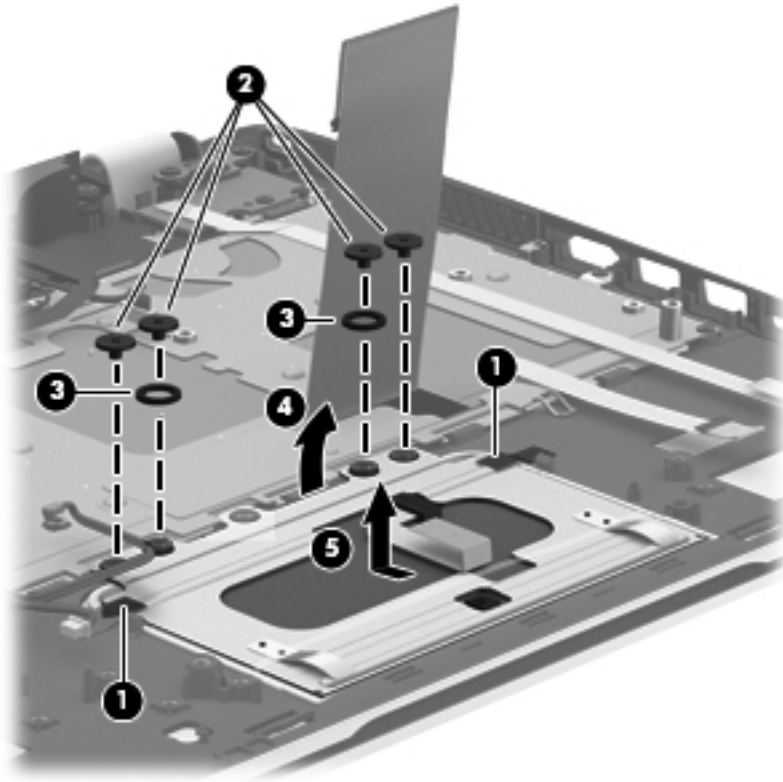

Reverse this procedure to install the TouchPad.

Power button board

Description	Spare part number
Power button board (includes cable)	720553-001

Before removing the power button board, follow these steps:

1. Turn off the computer. If you are unsure whether the computer is off or in Hibernation, turn the computer on, and then shut it down through the operating system.
2. Disconnect the power from the computer by unplugging the power cord from the computer.
3. Disconnect all external devices from the computer.
4. Remove the battery (see [Battery on page 43](#)), and then remove the following components:
 - a. Solid-state drive (see [Solid-state drive on page 44](#))
 - b. Hard drive (see [Hard drive on page 47](#))
 - c. Base enclosure (see [Base enclosure on page 55](#))
 - d. System board (see [System board on page 66](#))

Remove the power button board:

1. Detach the power button board cable **(1)** from the top cover. (The power button board cable is attached to the top cover with double-sided tape.)
2. Remove the Phillips PM2.0×2.9 screw **(2)** that secures the power button board to the top cover.
3. Release the clip **(3)** that secures the power button board to the top cover.

4. Remove the power button board (4).

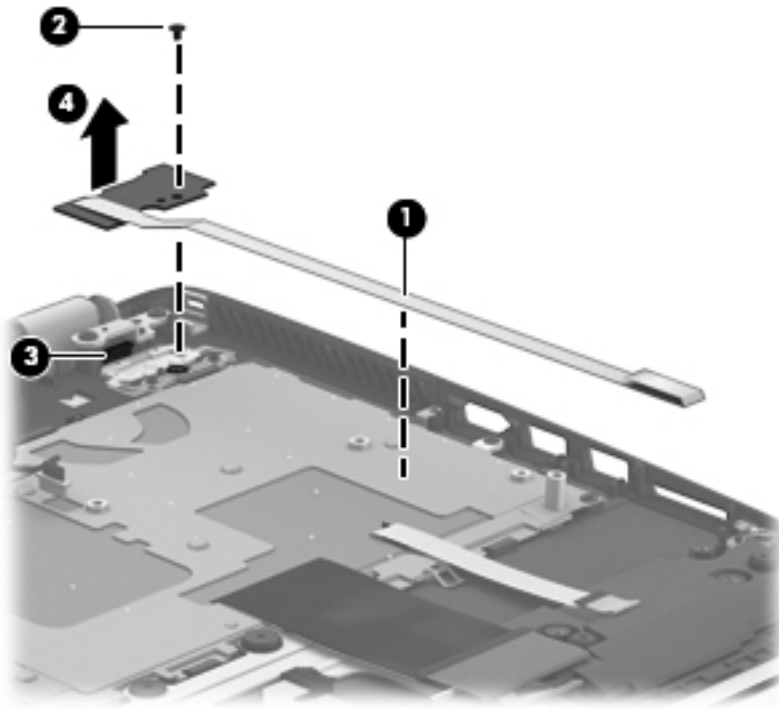

Reverse this procedure to install the power button board.

Keyboard



NOTE: The keyboard spare part kit includes a keyboard cable.

For use in country/region		Spare part number	
Keyboard with backlight (includes backlight cable):			
For use only on computer models equipped with an Intel processor in Belgium	720244-A41	For use only on computer models equipped with an Intel processor in Portugal	720244-131
For use on all computer models in Canada	720244-DB1	For use only on computer models equipped with an Intel processor in Russia	720244-251
For use only on computer models equipped with an Intel processor in the Czech Republic and Slovakia	720244-FL1	For use only on computer models equipped with an Intel processor in Saudi Arabia	720244-171
For use only on computer models equipped with an Intel processor in Denmark, Finland, and Norway	720244-DH1	For use only on computer models equipped with an Intel processor in South Korea	720244-AD1
For use only on computer models equipped with an Intel processor in France	720244-051	For use only on computer models equipped with an Intel processor in Spain	720244-071
For use only on computer models equipped with an Intel processor in Germany	720244-041	For use only on computer models equipped with an Intel processor in Switzerland	720244-BG1
For use only on computer models equipped with an Intel processor in Greece	720244-151	For use only on computer models equipped with an Intel processor in Taiwan	720244-AB1
For use only on computer models equipped with an Intel processor in Italy	720244-061	For use only on computer models equipped with an Intel processor in Thailand	720244-281
For use on all computer models in Japan	720244-291	For use only on computer models equipped with an Intel processor in Turkey	720244-141
For use on all computer models in Latin America	720244-161	For use only on computer models equipped with an Intel processor in the United Kingdom and Singapore	720244-031
For use only on computer models equipped with an Intel processor in the Netherlands	720244-B31	For use on all computer models in the United States	720244-001
Keyboard with pointing stick for use on all computer models in the United States (includes pointing stick cable)			720242-001

Before removing the keyboard, follow these steps:

1. Turn off the computer. If you are unsure whether the computer is off or in Hibernation, turn the computer on, and then shut it down through the operating system.
2. Disconnect the power from the computer by unplugging the power cord from the computer.
3. Disconnect all external devices from the computer.
4. Remove the battery (see [Battery on page 43](#)), and then remove the following components:
 - a. Solid-state drive (see [Solid-state drive on page 44](#))
 - b. Hard drive (see [Hard drive on page 47](#))
 - c. Base enclosure (see [Base enclosure on page 55](#))
 - d. System board (see [System board on page 66](#))
 - e. Connector board (see [Connector board on page 80](#))
 - f. Subwoofer (see [Subwoofer on page 83](#))
 - g. Rear speaker (see [Rear speakers on page 85](#))
 - h. Power button board (see [Power button board on page 93](#))

Remove the keyboard:

1. Remove the seven Phillips PM2.0×2.9 screws **(1)** that secure the keyboard shield to the computer.
2. Release the ground loop tape **(2)**.

3. Remove the keyboard shield **(3)**.

⚠ CAUTION: When removing the keyboard shield, make sure the keyboard cable and backlight cable are not damaged when being released through the opening in the keyboard shield.

The keyboard shield is available using spare part number .

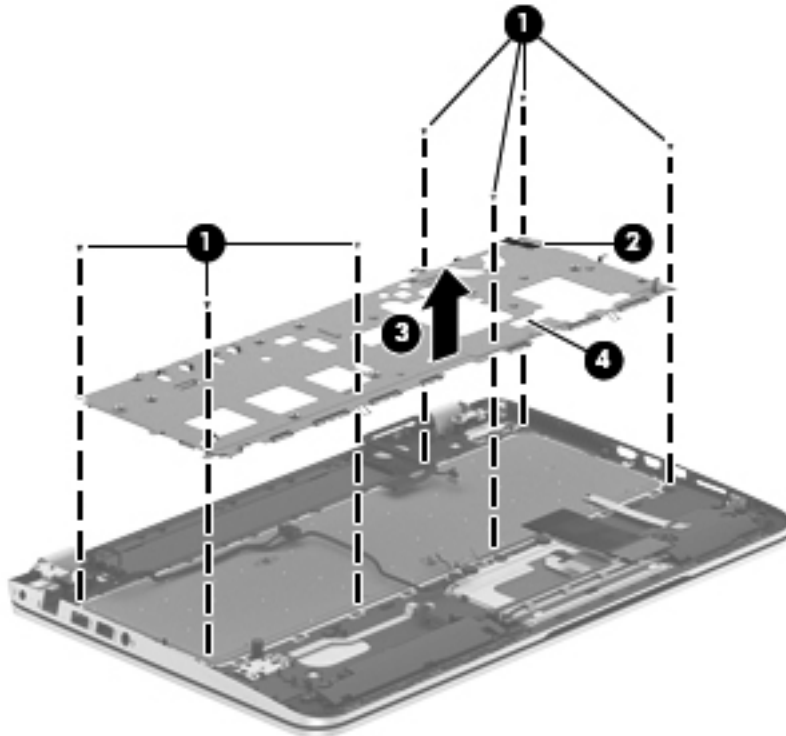

4. Partially open the computer.
5. Insert a thin tool into the keyboard release hole in the memory module compartment, and then press on the back of the keyboard until the keyboard disengages from the computer.
6. Turn the computer right-side up with the front toward you.
7. Remove the two Phillips PM2.0×2.9 screws **(1)** that secure the keyboard to the top cover.
8. Release the keyboard **(2)** by sliding it toward the TouchPad.

9. Remove the keyboard (3).

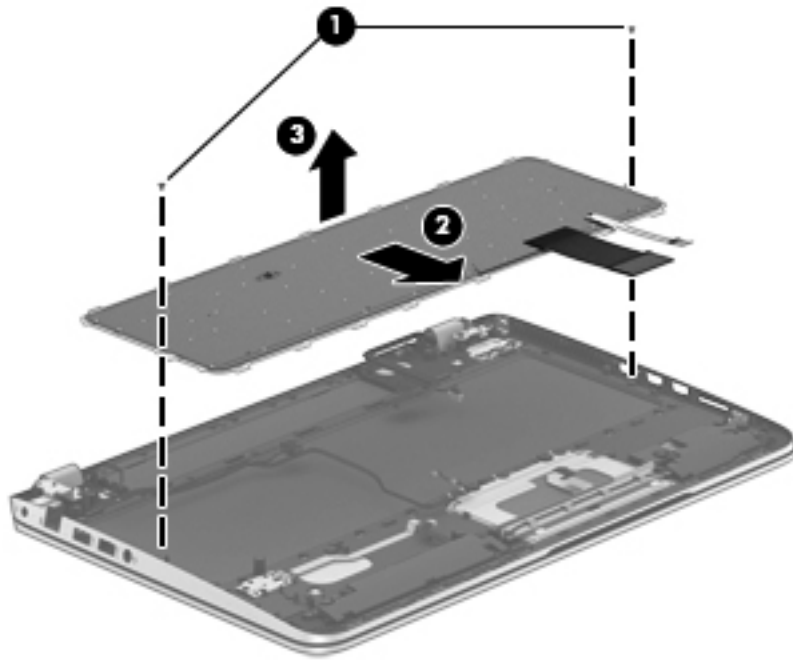

Reverse this procedure to install the keyboard.

7 Using Setup Utility (BIOS) and System Diagnostics

Setup Utility, or Basic Input/Output System (BIOS), controls communication between all the input and output devices on the system (such as disk drives, display, keyboard, mouse, and printer). Setup Utility (BIOS) includes settings for the types of devices installed, the startup sequence of the computer, and the amount of system and extended memory.

Starting Setup Utility (BIOS)

To start Setup Utility (BIOS), turn on or restart the computer, quickly press **esc**, and then press **f10**.

Information about how to navigate in Setup Utility (BIOS) is located at the bottom of the screen.

 **NOTE:** Use extreme care when making changes in Setup Utility (BIOS). Errors can prevent the computer from operating properly.

Updating the BIOS

Updated versions of the BIOS may be available on the HP website.

Most BIOS updates on the HP website are packaged in compressed files called *SoftPaqs*.

Some download packages contain a file named *Readme.txt*, which contains information regarding installing and troubleshooting the file.

Determining the BIOS version

To determine whether available BIOS updates contain later BIOS versions than those currently installed on the computer, you need to know the version of the system BIOS currently installed.

BIOS version information (also known as ROM date and System BIOS) can be revealed by pressing **fn + esc** (if you are already in Windows) or by using Setup Utility (BIOS).

1. Start Setup Utility (BIOS).
2. Use the arrow keys to select **Main**.
3. To exit Setup Utility (BIOS) without saving your changes, use the arrow keys to select **Exit**, select **Exit Discarding Changes**, and then press **enter**.

Downloading a BIOS update

 **CAUTION:** To reduce the risk of damage to the computer or an unsuccessful installation, download and install a BIOS update only when the computer is connected to reliable external power using the AC adapter. Do not download or install a BIOS update while the computer is running on battery power, docked in an optional docking device, or connected to an optional power source. During the download and installation, follow these instructions:

Do not disconnect power from the computer by unplugging the power cord from the AC outlet.

Do not shut down the computer or initiate Sleep.

Do not insert, remove, connect, or disconnect any device, cable, or cord.

1. From the Start screen, type `support`, and then select the **HP Support Assistant** app.
2. Click **Updates and tune-ups**, and then click **Check for HP updates** now.
3. Follow the on-screen instructions.
4. At the download area, follow these steps:
 - a. Identify the most recent BIOS update and compare it to the BIOS version currently installed on your computer. If the update is more recent than your BIOS, make a note of the date, name, or other identifier. You may need this information to locate the update later, after it has been downloaded to your hard drive.
 - b. Follow the on-screen instructions to download your selection to the hard drive.

If the update is more recent than your BIOS, make a note of the path to the location on your hard drive where the BIOS update is downloaded. You will need to access this path when you are ready to install the update.

 **NOTE:** If you connect your computer to a network, consult the network administrator before installing any software updates, especially system BIOS updates.

BIOS installation procedures vary. Follow any instructions that are revealed on the screen after the download is complete. If no instructions are revealed, follow these steps:

1. From the Start screen, type `e`, and then select **File Explorer**.
2. Click your hard drive designation. The hard drive designation is typically Local Disk (C:).
3. Using the hard drive path you recorded earlier, open the folder on your hard drive that contains the update.
4. Double-click the file that has an `.exe` extension (for example, `filename.exe`).

The BIOS installation begins.
5. Complete the installation by following the on-screen instructions.

 **NOTE:** After a message on the screen reports a successful installation, you can delete the downloaded file from your hard drive.

Using System Diagnostics

To start System Diagnostics:

1. Turn on or restart the computer, quickly press **esc**, and then press **f2**.
2. Click the diagnostic test you want to run, and then follow the on-screen instructions.



NOTE: If you need to stop a diagnostic test while it is running, press **esc**.

8 Specifications

Computer specifications

	Metric	U.S.
Dimensions		
HP ENVY TouchSmart 15 Notebook PC		
Width	37.95 cm	14.94 in
Depth	25.07 cm	9.87 in
Height (front to rear)	1.89 to 2.99 cm	0.74 to 1.18 in
Weight	2.76 kg	6.08 lbs
HP ENVY 15 Notebook PC		
Width	37.95 cm	14.94 in
Depth	25.07 cm	9.87 in
Height (front to rear)	1.69 to 2.79 cm	0.67 to 1.10 in
Weight	2.20 kg	4.85 lbs
Input power		
Operating voltage and current	19.5 V dc @ 3.33 A – 65 W	
	19.5 V dc @ 4.62 A – 90 W	
	19.5 V dc @ 6.15 A – 120 W (select models only)	
Temperature		
Operating	5°C to 35°C	41°F to 95°F
Nonoperating	-20°C to 60°C	-4°F to 140°F
Relative humidity (noncondensing)		
Operating	10% to 90%	
Nonoperating	5% to 95%	
Maximum altitude (unpressurized)		
Operating	-15 m to 3,048 m	-50 ft to 10,000 ft

	Metric	U.S.
Nonoperating	-15 m to 12,192 m	-50 ft to 40,000 ft

NOTE: Applicable product safety standards specify thermal limits for plastic surfaces. The device operates well within this range of temperatures.

15.6-inch display specifications

	Metric	U.S.
Dimensions		
Height	19.60 cm	7.72 in
Width	34.70 cm	13.66 in
Diagonal	39.80 cm	15.67 in
Number of colors	Up to 16.8 million	
Contrast ratio	200:1 (typical)	
Brightness	300 nits and 200 nits (typical)	
Pixel resolution		
Pitch	0.197 × 0.197 mm	
Format	1366 × 768	
Configuration	RGB vertical stripe	
Backlight	LED	
Character display	80 × 25	
Total power consumption	2.00 W	
Viewing angle	±65° horizontal, ±50° vertical (typical)	

Hard drive specifications

	1-TB, 5400-rpm*	750-GB, 5400-rpm**	500-GB, 5400-rpm**
Dimensions			
Height	9.5 mm	9.5 mm	9.5 and 7.0 mm
Length	100.4 mm	100.4 mm	100.4 mm
Width	69.9 mm	69.9 mm	69.9 mm
Weight	110 g	110 g	110 g
Interface type	SATA	SATA	SATA
Transfer rate			
Synchronous (maximum)	1.1 GB/sec	1.1 GB/sec	1.1 GB/sec
Security	ATA security	ATA security	ATA security
Seek times (typical read, including setting)			
Single track	1.5 ms	1.5 ms	1.5 ms
Average (read/write)	11/13 ms	11/13 ms	11/13 ms
Maximum	22 ms	22 ms	22 ms
Logical blocks	1,953,525,168	1,465,149,168	976,773,168
Disk rotational speed	5400 rpm		
Operating temperature	0°C to 60°C (32°F to 140°F)		
* 1 TB = 1 trillion bytes when referring to hard drive storage capacity. Actual accessible capacity is less.			
** 1 GB = 1 billion bytes when referring to hard drive storage capacity. Actual accessible capacity is less.			
NOTE: Certain restrictions and exclusions apply. Contact technical support for details.			

9 Backing up, restoring, and recovering

Your computer includes tools provided by HP and the operating system to help you safeguard your information and retrieve it if you ever need to. These tools will help you return your computer to a proper working state or even back to the original factory state, all with simple steps.

This chapter provides information about the following processes:

- Creating recovery media and backups
- Restoring and recovering your system

 **NOTE:** This guide describes an overview of backing up, restoring and recovering options. For more details about the tools provided, see Help and Support. From the Start screen, type **h**, and then select **Help and Support**.

Creating recovery media and backups

Recovery after a system failure is only as good as your most recent backup.

1. After you successfully set up the computer, create HP Recovery media. This step creates a backup of the HP Recovery partition on the computer. The backup can be used to reinstall the original operating system in cases where the hard drive is corrupted or has been replaced.

HP Recovery media you create will provide the following recovery options:

- System Recovery—Reinstalls the original operating system and the programs that were installed at the factory.
 - Minimized Image Recovery—Reinstalls the operating system and all hardware-related drivers and software, but not other software applications.
 - Factory Reset—Restores the computer to its original factory state by deleting all information from the hard drive and re-creating the partitions. Then it reinstalls the operating system and the software that was installed at the factory.
2. As you add hardware and software programs, create system restore points. A system restore point is a snapshot of certain hard drive contents saved by Windows System Restore at a specific time. A system restore point contains information that Windows uses, such as registry settings. Windows creates a system restore point for you automatically during a Windows update and during other system maintenance (such as a software update, security scanning, or system diagnostics). You can also manually create a system restore point at any time. For more information and steps for creating specific system restore points, see Help and Support. From the Start screen, type **h**, and then select **Help and Support**.
 3. As you add photos, video, music, and other personal files, create a backup of your personal information. Windows File History can be set to regularly and automatically back up files from libraries, desktop, contacts, and favorites. If files are accidentally deleted from the hard drive and they can no longer be restored from the Recycle Bin, or if files become corrupted, you can restore the files that you backed up using File History. Restoring files is also useful if you ever choose to reset the computer by reinstalling Windows or choose to recover using HP Recovery Manager.



NOTE: File History is not enabled by default, so you must turn it on.

For more information and steps for enabling Windows File History, see Help and Support. From the Start screen, type **h**, and then select **Help and Support**.

Creating HP Recovery media

HP Recovery Manager is a software program that offers a way to create recovery media after you successfully set up the computer. HP Recovery media can be used to perform system recovery if the hard drive becomes corrupted. System recovery reinstalls the original operating system and the software programs installed at the factory, and then configures the settings for the programs. HP Recovery media can also be used to customize the system or aid in the replacement of a hard drive.

- Only one set of HP Recovery media can be created. Handle these recovery tools carefully, and keep them in a safe place.
- HP Recovery Manager examines the computer and determines the required storage capacity for the blank USB flash drive or the number of blank DVD discs that will be required.
- To create recovery discs, your computer must have an optical drive with DVD writer capability, and you must use only high-quality blank DVD-R, DVD+R, DVD-R DL, or DVD+R DL discs. Do not use rewritable discs such as CD±RW, DVD±RW, double-layer DVD±RW, or BD-RE (rewritable Blu-ray) discs; they are not compatible with HP Recovery Manager software. Or instead you can use a high-quality blank USB flash drive.
- If your computer does not include an integrated optical drive with DVD writer capability, but you would like to create DVD recovery media, you can use an external optical drive (purchased separately) to create recovery discs, or you can obtain recovery discs for your computer from the HP website. For U.S. support, go to <http://www.hp.com/go/contactHP>. For worldwide support, go to http://welcome.hp.com/country/us/en/wwcontact_us.html. If you use an external optical drive, it must be connected directly to a USB port on the computer; the drive cannot be connected to a USB port on an external device, such as a USB hub.
- Be sure that the computer is connected to AC power before you begin creating the recovery media.
- The creation process can take up to an hour or more. Do not interrupt the creation process.
- If necessary, you can exit the program before you have finished creating all of the recovery DVDs. HP Recovery Manager will finish burning the current DVD. The next time you start HP Recovery Manager, you will be prompted to continue, and the remaining discs will be burned.

To create HP Recovery media:

1. From the Start screen, type `recovery`, and then select **HP Recovery Manager**.
2. Select **Recovery Media Creation**, and then follow the on-screen instructions.

If you ever need to recover the system, see [Recovering using HP Recovery Manager on page 110](#).

Restore and recovery

There are several options for recovering your system. Choose the method that best matches your situation and level of expertise:

- If you need to restore your personal files and data, you can use Windows File History to restore your information from the backups you created. For more information and steps for using File History, see Help and Support. From the Start screen, type `h`, and then select **Help and Support**.
- If you need to correct a problem with a preinstalled application or driver, use the Drivers and Applications Reinstall option of HP Recovery Manager to reinstall the individual application or driver.

From the Start screen, type `recovery`, select **HP Recovery Manager**, select **Drivers and Applications Reinstall**, and then follow the on-screen instructions.

- If you want to restore the system to a previous state without losing any personal information, Windows System Restore is an option. System Restore allows you to restore without the requirements of Windows Refresh or a reinstallation. Windows creates system restore points automatically during a Windows update and other system maintenance events. Even if you did not manually create a restore point, you can choose to restore to a previous point, automatically created. For more information and steps for using Windows System Restore, see Help and Support. From the Start screen, type `h`, and then select **Help and Support**.
- If you want a quick and easy way to recover the system without losing your personal information, settings, or apps that came preinstalled on your computer or were purchased from the Windows Store, consider using Windows Refresh. This option does not require backing up data to another drive. See [Using Windows Refresh for quick and easy recovery on page 109](#).
- If you want to reset your computer to its original state, Windows provides an easy way to remove all personal data, apps, and settings, and reinstall Windows.

For more information, see [Remove everything and reinstall Windows on page 109](#).

- If you want to reset your computer using a minimized image, you can choose the HP Minimized Image Recovery option from the HP Recovery partition (select models only) or HP Recovery media. Minimized Image Recovery installs only drivers and hardware-enabling applications. Other applications included in the image continue to be available for installation through the Drivers and Applications Reinstall option in HP Recovery Manager.

For more information, see [Recovering using HP Recovery Manager on page 110](#).

- If you want to recover the computer's original factory partitioning and content, you can choose the System Recovery option from the HP Recovery media. For more information, see [Recovering using HP Recovery Manager on page 110](#).
- If you have replaced the hard drive, you can use the Factory Reset option of HP Recovery media to restore the factory image to the replacement drive. For more information, see [Recovering using HP Recovery Manager on page 110](#).
- If you wish to remove the recovery partition to reclaim hard drive space, HP Recovery Manager offers the Remove Recovery Partition option.

For more information, see [Removing the HP Recovery partition on page 112](#).

Using Windows Refresh for quick and easy recovery

When your computer is not working properly and you need to regain system stability, the Windows Refresh option allows you to start fresh and keep what is important to you.

 **IMPORTANT:** Refresh removes any traditional applications that were not originally installed on the system at the factory.

 **NOTE:** During Refresh, a list of removed traditional applications will be saved so that you have a quick way to see what you might need to reinstall. See Help and Support for instructions on reinstalling traditional applications. From the Start screen, type **h**, and then select **Help and Support**.

 **NOTE:** You may be prompted for your permission or password when using Refresh. See Help and Support for more information. From the Start screen, type **h**, and then select **Help and Support**.

To start Refresh:

1. From the Start screen, point to the upper-right or lower-right corner of the screen to reveal the charms.
2. Click **Settings**.
3. Click **Change PC settings** in the bottom-right corner of the screen, and then select **General** from the PC settings screen.
4. Under **Refresh your PC without affecting your files**, select **Get started**, and then follow the on-screen instructions.

Remove everything and reinstall Windows

Sometimes you want to perform detailed reformatting of your computer, or you want to remove personal information before you give away or recycle your computer. The process described in this section provides a speedy, simple way to return the computer to its original state. This option removes all personal data, apps, and settings from your computer, and reinstalls Windows.

 **IMPORTANT:** This option does not provide backups of your information. Before using this option, back up any personal information you wish to retain.

You can initiate this option by using the **f11** key or from the Start screen.

To use the **f11** key:

1. Press **f11** while the computer boots.
– or –
Press and hold **f11** as you press the power button.
2. Select **Troubleshoot** from the boot options menu.
3. Select **Reset your PC**, and then follow the on-screen instructions.

To use the Start screen:

1. From the Start screen, point to the upper-right or lower-right corner of the screen to reveal the charms.
2. Click **Settings**.
3. Click **Change PC settings** in the bottom-right corner of the screen, and then select **General** from the PC settings screen.
4. Under **Remove everything and reinstall Windows**, select **Get started**, and follow the on-screen instructions.

Recovering using HP Recovery Manager

HP Recovery Manager software allows you to recover the computer to its original factory state. Using the HP Recovery media you created, you can choose from one of the following recovery options:

- System Recovery—Reinstalls the original operating system, and then configures the settings for the programs that were installed at the factory.
- Minimized Image Recovery—Reinstalls the operating system and all hardware-related drivers and software, but not other software applications.
- Factory Reset—Restores the computer to its original factory state by deleting all information from the hard drive and re-creating the partitions. Then it reinstalls the operating system and the software that was installed at the factory.

The HP Recovery partition (select models only) allows Minimized Image Recovery.

What you need to know

- HP Recovery Manager recovers only software that was installed at the factory. For software not provided with this computer, you must either download the software from the manufacturer's website or reinstall the software from the media provided by the manufacturer.
- Recovery through HP Recovery Manager should be used as a final attempt to correct computer issues.
- HP Recovery media must be used if the computer hard drive fails.
- To use the Factory Reset or System Recovery options, you must use HP Recovery media.
- If the HP Recovery media do not work, you can obtain recovery media for your system from the HP website. For U.S. support, go to <http://www.hp.com/go/contactHP>. For worldwide support, go to http://welcome.hp.com/country/us/en/wwcontact_us.html.



IMPORTANT: HP Recovery Manager does not automatically provide backups of your personal data. Before beginning recovery, back up any personal data you wish to retain.

Using the HP Recovery partition to recover a minimized image (select models only)

The HP Recovery partition (select models only) allows you to perform a minimized image recovery without the need for recovery discs or a recovery USB flash drive. This type of recovery can only be used if the hard drive is still working.

To start HP Recovery Manager from the HP Recovery partition:

1. Press **f11** while the computer boots.
– or –
Press and hold **f11** as you press the power button.
2. Select **Troubleshoot** from the boot options menu.
3. Select **HP Recovery Manager**, and follow the on-screen instructions.

Using HP Recovery media to recover

You can use HP Recovery media to recover the original system. This method can be used if your system does not have an HP Recovery partition or if the hard drive is not working properly.

1. If possible, back up all personal files.
2. Insert the first HP Recovery disc you created into the optical drive on your computer or into an optional external optical drive, and then restart the computer.

– or –

Insert the HP Recovery USB flash drive you created into a USB port on your computer, and then restart the computer.

 **NOTE:** If the computer does not automatically restart in HP Recovery Manager, change the computer boot order. See [Changing the computer boot order on page 111](#).

3. Follow the on-screen instructions.

Changing the computer boot order

If computer does not restart in HP Recovery Manager, you can change the computer boot order, which is the order of devices listed in BIOS where the computer looks for startup information. You can change the selection for an optical drive or a USB flash drive.

To change the boot order:

1. Insert the HP Recovery media you created.
2. Restart the computer.
3. Press and hold **esc** while the computer is restarting, and then press **f9** for boot options.

4. Select the optical drive or USB flash drive you want to boot from.
5. Follow the on-screen instructions.

Removing the HP Recovery partition

HP Recovery Manager software allows you to remove the HP Recovery partition to free up hard drive space.



IMPORTANT: Removing the HP Recovery partition means you can no longer use Windows Refresh, the Windows Remove everything and reinstall Windows option, or the HP Recovery Manager option for minimized image recovery. Create HP Recovery media before removing the Recovery partition to ensure you have recovery options; see [Creating HP Recovery media on page 107](#).

Follow these steps to remove the HP Recovery partition:

1. From the Start screen, type recovery, and then select HP Recovery Manager.
2. Select Remove Recovery Partition, and then follow the on-screen instructions.

10 Power cord set requirements

The wide-range input feature of the computer permits it to operate from any line voltage from 100 to 120 volts AC, or from 220 to 240 volts AC.

The 3-conductor power cord set included with the computer meets the requirements for use in the country or region where the equipment is purchased.

Power cord sets for use in other countries and regions must meet the requirements of the country or region where the computer is used.

Requirements for all countries

The following requirements are applicable to all countries and regions:

- The length of the power cord set must be at least **1.0 m** (3.3 ft) and no more than **2.0 m** (6.5 ft).
- All power cord sets must be approved by an acceptable accredited agency responsible for evaluation in the country or region where the power cord set will be used.
- The power cord sets must have a minimum current capacity of 10 amps and a nominal voltage rating of 125 or 250 V AC, as required by the power system of each country or region.
- The appliance coupler must meet the mechanical configuration of an EN 60 320/IEC 320 Standard Sheet C13 connector for mating with the appliance inlet on the back of the computer.

Requirements for specific countries and regions

Country/region	Accredited agency	Applicable note number
Australia	EANSW	1
Austria	OVE	1
Belgium	CEBC	1
Canada	CSA	2
Denmark	DEMKO	1
Finland	FIMKO	1
France	UTE	1
Germany	VDE	1
Italy	IMQ	1
Japan	METI	3
The Netherlands	KEMA	1
Norway	NEMKO	1
The People's Republic of China	COC	5
South Korea	EK	4
Sweden	SEMKO	1
Switzerland	SEV	1
Taiwan	BSMI	4
The United Kingdom	BSI	1
The United States	UL	2

1. The flexible cord must be Type HO5VV-F, 3-conductor, 1.0-mm² conductor size. Power cord set fittings (appliance coupler and wall plug) must bear the certification mark of the agency responsible for evaluation in the country or region where it will be used.
2. The flexible cord must be Type SPT-3 or equivalent, No. 18 AWG, 3-conductor. The wall plug must be a two-pole grounding type with a NEMA 5-15P (15 A, 125 V) or NEMA 6-15P (15 A, 250 V) configuration.
3. The appliance coupler, flexible cord, and wall plug must bear a "T" mark and registration number in accordance with the Japanese Dentori Law. The flexible cord must be Type VCT or VCTF, 3-conductor, 1.00-mm² conductor size. The wall plug must be a two-pole grounding type with a Japanese Industrial Standard C8303 (7 A, 125 V) configuration.
4. The flexible cord must be Type RVV, 3-conductor, 0.75-mm² conductor size. Power cord set fittings (appliance coupler and wall plug) must bear the certification mark of the agency responsible for evaluation in the country or region where it will be used.
5. The flexible cord must be Type VCTF, 3-conductor, 0.75-mm² conductor size. Power cord set fittings (appliance coupler and wall plug) must bear the certification mark of the agency responsible for evaluation in the country or region where it will be used.

11 Recycling

When a non-rechargeable or rechargeable battery has reached the end of its useful life, do not dispose of the battery in general household waste. Follow the local laws and regulations in your area for battery disposal.

HP encourages customers to recycle used electronic hardware, HP original print cartridges, and rechargeable batteries. For more information about recycling programs, see the HP Web site at <http://www.hp.com/recycle>.

Index

- A**
 - AC adapter light 17
 - AC adapter, spare part numbers 29, 31
 - action keys 12
 - antenna
 - locations 10
 - removal 64
 - spare part number 27, 33, 65
 - Antenna Kit, spare part number 27, 33
 - audio, product description 6
 - audio-in jack 17
 - audio-out jack 17
- B**
 - base enclosure
 - removal 55
 - spare part number 25, 33, 55
 - battery
 - removal 43
 - spare part numbers 26, 31, 43
 - battery bay 18
 - battery release latch 18
 - bottom components 18
 - button components 11
 - buttons
 - power 11
 - TouchPad 14
- C**
 - cables, service considerations 38
 - caps lock light 14
 - chipset, product description 2
 - components
 - bottom 18
 - buttons 11
 - display 10
 - keys 12
 - left-side 15
 - lights 13
 - right-side 17
 - speakers 11
 - TouchPad 14
 - computer
 - major components 21
 - specifications 102
 - connector board
 - removal 80
 - spare part numbers 23, 34, 35, 80
 - connectors, service considerations 38
- D**
 - Digital Media Card Reader 15
 - display
 - components 10
 - specifications 103
 - display assembly
 - removal 57
 - spare part numbers 22, 33, 57
 - display bezel
 - removal 60
 - spare part number 27, 33, 61
 - display enclosure, spare part number 27, 33
 - display panel
 - product description 4
 - removal 62
 - spare part numbers 27, 34, 62
 - display panel cable
 - removal 62
 - spare part number 27, 33, 63
 - drives, preventing damage 38
 - DVD±RW Double-Layer with SuperMulti Drive
 - precautions 38
 - spare part number 28, 30
- E**
 - electrostatic discharge 39
 - equipment guidelines 41
 - esc key 12
 - Ethernet, product description 6
- F**
 - fan
 - removal 65
 - spare part number 25, 32, 65
 - fingerprint reader board
 - removal 87
 - spare part number 23, 33, 87
 - fingerprint reader light 14
 - fingerprint reader, location 12
 - fn key 12
 - front speakers
 - removal 88
 - spare part number 25, 34, 88
- G**
 - graphics, product description 3
 - grounding guidelines 39
 - guidelines
 - equipment 41
 - grounding 39
 - packaging 40
 - transporting 40
 - workstation 40
- H**
 - hard drive
 - precautions 38
 - product description 5

- removal 47
- spare part numbers 26, 28, 30, 31, 47
- specifications 104
- hard drive bracket
 - illustrated 28
 - removal 48
- hard drive connector cable
 - illustrated 28
 - removal 48
- Hard Drive Hardware Kit
 - contents 28
 - spare part number 26, 28, 33
- hard drive light 16
- HDMI port 15
- HDMI-to-VGA adapter, spare part number 29, 31
- headphone jack 17
- heat sink
 - removal 72
 - spare part numbers 25, 33, 35, 72
- hinge
 - removal 63
 - spare part number 27, 33, 63
- hinge bracket
 - removal 63
 - spare part number 64
- hinge cover
 - removal 61
 - spare part number 61

I
integrated numeric keypad 12

J
jacks

- audio-in 17
- audio-out 17
- headphone 17
- microphone 17
- network 17
- RJ-45 (network) 17

K
key components 12
keyboard

- product description 7
- removal 95
- spare part numbers 22, 32, 33, 95

- keyboard shield
 - removal 96
 - spare part number 23, 33, 97
- keys
 - action 12
 - esc 12
 - fn 12
 - integrated numeric keypad 12
 - num lk 12
 - Windows key 12

L
left-side components 15
light components 13
lights

- AC adapter 17
- caps lock 14
- fingerprint reader 14
- hard drive 16
- mute 13
- power 13, 16
- RJ-45 (network) status 17
- webcam 10
- wireless 13

M
mass storage device

- illustrated 28
- precautions 38
- spare part numbers 28

 memory module

- product description 5
- removal 49
- spare part numbers 26, 31, 49

microphone

- location 10
- product description 6

 microphone jack 17
 model name 1
 mute light 13

N
network jack 17
num lk key 12

O
operating system, product description 8

optical drive

- precautions 38
- spare part number 28, 30

P
packaging guidelines 40
plastic parts, service considerations 37
pointing device, product description 7
ports

- HDMI 15
- product description 7
- USB 3.0 15, 17

 power button 11
 power button board

- removal 93
- spare part number 22, 34, 93

 power connector 17
 power connector cable

- removal 82
- spare part numbers 23, 33, 82

 power cord

- set requirements 113
- spare part numbers 29, 30

 power light 13, 16
 power requirements, product description 7
 processor

- removal 77
- spare part numbers 24, 31, 35, 36, 77

 processor, product description 1
 product description

- audio 6
- chipset 2
- display panel 4
- Ethernet 6
- external media cards 6
- graphics 3
- hard drive 5
- keyboard 7
- memory module 5
- microphone 6
- operating system 8
- pointing device 7
- ports 7
- power requirements 7
- processors 1

- product name 1
 - security 8
 - serviceability 8
 - solid-state drive 5
 - video 6
 - wireless 6
 - product name 1
- R**
- rear speakers
 - removal 85
 - spare part number 23, 34, 85
 - removal/replacement
 - procedures 42, 52
 - right-side components 17
 - RJ-45 (network) jack 17
 - RJ-45 (network) jack status light 17
 - RTC battery
 - removal 52
 - spare part numbers 25, 30, 31, 52
 - rubber feet
 - removal 55
 - spare part number 55
 - Rubber Kit, spare part number 25, 34
- S**
- Screw Kit, spare part number 29, 34
 - security cable slot, location 15
 - security, product description 8
 - service considerations
 - cables 38
 - connectors 38
 - plastic parts 37
 - service cover
 - location 18
 - removal 44
 - spare part number 26, 34, 44
 - service tag 19
 - serviceability, product description 8
 - solid-state drive
 - precautions 38
 - product description 5
 - removal 44
 - spare part number 26, 28, 34, 44
 - speaker components 11
 - speakers
 - location 12, 18
 - removal 83, 85, 88
 - spare part numbers 23, 25, 34, 83, 85, 88
 - specifications
 - computer 102
 - display 103
 - hard drive 104
 - subwoofer
 - location 18
 - removal 83
 - spare part number 25, 34, 83
 - system board
 - removal 66
 - spare part numbers 23, 34, 35, 66
- T**
- tools required 37
 - top cover, spare part number 22, 35
 - TouchPad assembly
 - removal 90
 - spare part number 23, 35, 90
 - TouchPad button 14
 - TouchPad components 14
 - TouchPad zone 14
 - transporting guidelines 40
- U**
- USB 3.0 port 15, 17
- V**
- vent 15, 18
 - video, product description 6
- W**
- webcam 10
 - webcam light 10
 - webcam/microphone module
 - removal 64
 - spare part number 27, 33, 64
 - Windows key 12
 - wireless antenna
 - locations 10
 - removal 64
 - spare part number 27, 33, 65
 - wireless light 13
 - wireless, product description 6
 - WLAN module
 - removal 45
 - spare part numbers 25, 30, 31, 45
 - workstation guidelines 40