



HP Pavillion Sleekbook 14

Maintenance and Service Guide

© Copyright 2013 Hewlett-Packard
Development Company, L.P.

AMD, the AMD Arrow logo, and combinations thereof, are trademarks of Advanced Micro Devices, Inc. Bluetooth is a trademark owned by its proprietor and used by Hewlett-Packard Company under license. Microsoft and Windows are U.S. registered trademarks of Microsoft Corporation. SD Logo is a trademark of its proprietor.

The information contained herein is subject to change without notice. The only warranties for HP products and services are set forth in the express warranty statements accompanying such products and services. Nothing herein should be construed as constituting an additional warranty. HP shall not be liable for technical or editorial errors or omissions contained herein.

First Edition: June 2013

Document Part Number: 718882-001

Product notice

This guide describes features that are common to most models. Some features may not be available on your computer.

Not all features are available in all editions of Windows 8. This computer may require upgraded and/or separately purchased hardware, drivers, and/or software to take full advantage of Windows 8 functionality. See for <http://www.microsoft.com> details.

Important Notice about Customer Self-Repair Parts

 **CAUTION:** Your computer includes Customer Self-Repair parts and parts that should only be accessed by an authorized service provider. See Chapter 5, "Removal and replacement procedures for Customer Self-Repair parts," for details. Accessing parts described in Chapter 6, "Removal and replacement procedures for Authorized Service Provider only parts," can damage the computer or void your warranty.

Safety warning notice

 **WARNING!** To reduce the possibility of heat-related injuries or of overheating the device, do not place the device directly on your lap or obstruct the device air vents. Use the device only on a hard, flat surface. Do not allow another hard surface, such as an adjoining optional printer, or a soft surface, such as pillows or rugs or clothing, to block airflow. Also, do not allow the AC adapter to contact the skin or a soft surface, such as pillows or rugs or clothing, during operation. The device and the AC adapter comply with the user-accessible surface temperature limits defined by the International Standard for Safety of Information Technology Equipment (IEC 60950).

Table of contents

1 Product description	1
2 External component identification	5
Finding your hardware and software information	5
Display	5
Button	7
Keys	8
Lights	9
TouchPad	10
Left side	11
Right side	13
Bottom	14
3 Illustrated parts catalog	15
Service tag	16
Computer major components	17
Mass storage devices	20
Miscellaneous parts	21
Sequential part number listing	21
4 Removal and replacement procedures preliminary requirements	24
Tools required	24
Service considerations	24
Plastic parts	24
Cables and connectors	25
Drive handling	25
Grounding guidelines	26
Electrostatic discharge damage	26
Packaging and transporting guidelines	27
Workstation guidelines	27

5 Removal and replacement procedures for Customer Self-Repair parts	29
Component replacement procedures	29
Battery	30
Keyboard	31
6 Removal and replacement procedures for Authorized Service Provider parts	33
Component replacement procedures	33
Top cover	33
Power button board	36
TouchPad button board	37
Hard drive	38
USB board	41
Fan	42
WLAN module	44
Display assembly	46
System board	49
Memory module	52
Hard drive connector cable	53
RTC battery	55
Heat sink	56
Power connector cable	58
Speakers	60
7 Using Setup Utility (BIOS) and System Diagnostics	62
Starting Setup Utility (BIOS)	62
Updating the BIOS	62
Determining the BIOS version	62
Downloading a BIOS update	63
Using System Diagnostics	64
8 Specifications	65
Computer specifications	65
14.0-in, SVA, display panel display specifications	66
Hard drive specifications	67
9 Backing up, restoring, and recovering	68
Creating recovery media and backups	68
Creating HP Recovery media	69
Restore and recovery	70
Using Windows Refresh for quick and easy recovery	71

Remove everything and reinstall Windows	72
Recovering using HP Recovery Manager	72
What you need to know	73
Using the HP Recovery partition to recover a minimized image (select models only)	73
Using HP Recovery media to recover	74
Changing the computer boot order	74
Removing the HP Recovery partition	74
10 Power cord set requirements	75
Requirements for all countries	75
Requirements for specific countries and regions	76
11 Recycling	77
Index	78

1 Product description

Category	Description
Product Name	HP Pavillion Sleekbook 14
Processors	<ul style="list-style-type: none">• A8-5545M (2.7GHz/1.7GHz, 4MB L2, 1333MHz DDR3L) Quad 19 W• A6-5200 (2.0GHz, 2MB L2, 1600MHz DDR3L), Quad 25 W• A4-5000 (1.5GHz, 2MB L2, 1600MHz DDR3L), Quad 15 W• E2-3000 (1.65GHz, 1MB L2, 1600MHz DDR3L), Dual 15 W and a UMA graphics subsystem memory
Chipset	AMD A76M FCH fusion controller hub chipset
Graphics	<p>Internal graphics:</p> <ul style="list-style-type: none">• AMD Radeon™ HD 8510G Graphics on computer models equipped with an A8-5545M processor• AMD Radeon™ HD 8410G Graphics on computer models equipped with an A6-5345M processor• AMD Radeon™ HD 8400 Graphics on computer models equipped with an A6-5200M processor• AMD Radeon™ HD 8330 Graphics on computer models equipped with an A4-5000 processor <p>Supports HD decode, DX11, and HDMI</p>
Panel	<p>14.0-in, light emitting diode (LED), HD, BrightView (1366x768) Slim (3.0mm) SVA + eTP touch (Multitouch enabled)</p> <p>All display assemblies include one or two wireless local area network (WLAN) antenna cables</p> <p>Supports low voltage differential signalling (LVDS)</p>

Category	Description
Memory	<p>Two customer-accessible/upgradable memory module slots</p> <p>DDR3-1333-MHz dual channel support (DDR3L-1600 downgrade to DDR3-1333)</p> <p>DDR3-1600MHz Single Channel Support</p> <p>Supports 8192-MB of system RAM in the following configurations:</p> <ul style="list-style-type: none"> • 8192-MB (4096-MB×2; not supported on computer models equipped with a 32-bit operating system) • 6144-MB (2048-MB×1 + 4096-MB×1; not supported on computer models equipped with a 32-bit operating system) • 4096-MB (2048-MB×2; not supported on computer models equipped with Windows 7, 32-bit operating system) • 4096-MB (4096-MB×1; not supported on computer models equipped with Windows 7, 32-bit operating system)
Hard drive	<p>Supports 6.35-cm (2.5-in) hard drives in 9.5-mm (.37-in) and 7.0-mm (.28-in) thicknesses (all hard drives use the same bracket)</p> <p>Customer-accessible</p> <p>Serial ATA</p> <p>Supports the following hard drives:</p> <ul style="list-style-type: none"> • 1-TB, 5400-rpm, 9.5-mm • 750-GB, 5400-rpm, 9.5-mm • 640-GB, 5400-rpm, 9.5-mm • 500-GB, 5400-rpm, 9.5-mm • 320-GB, 5400-rpm, 9.5-mm
Optical drive	<p>External</p> <p>Serial ATA</p> <p>12.7-mm tray load</p> <p>Supports DVD±RW Double-Layer with SuperMulti Drive</p>
Audio and video	<p>Two speakers</p> <p>DTS sound</p> <p>Supports Microsoft® premium requirements</p> <p>VGA webcam (fixed, no tilt with activity LED; 1280×720 by 30 frames per second)</p> <p>Two digital microphones with beam-forming, echo cancelling and noise suppressing software.</p> <p>Supports nuance voice recognition</p>
Ethernet	<p>Integrated 10/100 network interface card (NIC)</p>

Category	Description
Wireless	<p>Integrated wireless local area network (WLAN) options by way of wireless module</p> <p>One or two WLAN antennas built into display assembly, varying by computer model</p> <p>Support for the following WLAN formats:</p> <ul style="list-style-type: none"> • Atheros AR9485 802.11b/g/n 1×1 Wi-Fi Adapter • Ralink RT3290LE 802.11b/g/n 1×1 WiFi and Bluetooth® 4.0 Combo Adapter • Realtek RTL8188EE 802.11bg/n 1×1 WiFi Adapter
Memory Card Reader	<p>HP 2-In-1 multifomat Digital Media Reader Slot with push technology. Reads data from and writes data to digital memory cards such as Secure Digital (SD).</p>
Ports	<ul style="list-style-type: none"> • Audio-in (mono microphone) • Audio-out (stereo headphone) • HDMI v1.4 supporting: up to 1920×1080 @ 60Hz • Headphone/Microphone in combo jack • HP Smart Pin AC adapter • RJ-45 (Ethernet Gigabit support with LED indicators) • USB 2.0/3.0 ports on computer: 3 (2 on one side, 1 on other) • VGA (Dsub 15 pin) supporting: 2048×1536 external resolution @ 75Hz and 1920×2000 external resolution @ 60 Hz hot plug and unplug and auto detection for correct output to wide-aspect vs. standard aspect video
Keyboard/pointing devices	<p>Full-size, textured, island-style keyboard, no numeric keypad</p> <p>Touchpad</p> <p>Gesture support: MultiTouch gestures enabled, two-finger scrolling, and pinch-zoom as default</p> <p>Taps enabled by default</p>
Power requirements	<p>65W RC, V, EM, 3-wire HP Smart AC adapter with localized cable plug support (3-wire plug with ground pin, supports 3-pin DC connector)</p> <p>Supports 4-cell, 41-Wh, 2.80-Ah, Li-ion battery</p>
Security	<p>Supports security cable lock</p>

Category	Description
Operating system	Preinstalled: <ul style="list-style-type: none">• Microsoft® Windows 8 Professional• Microsoft Windows 8 Standard• FreeDOS 2.0• Ubuntu Linux
Serviceability	End user replaceable parts: <ul style="list-style-type: none">• AC adapter• Battery• Hard drive• Memory module• External optical drive• MiniCard Components

2 External component identification

Finding your hardware and software information

- ▲ Select **Start > Computer**.

A list displays all the devices installed in your computer, including hard drive, optical drives, solid-state drives (SSD), or a secondary hard drive.

To find out what software is included on your computer, select **Start > All Programs**.

Display



Item	Component	Description
(1)	Internal display switch	Turns off the display and initiates Sleep if the display is closed while the power is on. NOTE: The internal display switch is not visible from the outside of the computer.
(2)	WLAN antennas (2)*	Send and receive wireless signals to communicate with WLANs. NOTE: To set up a WLAN and connect to the Internet, you need a broadband modem (either DSL or cable) (purchased separately), high-speed Internet service purchased from an Internet service provider, and a wireless router (purchased separately).
(3)	Internal microphone	Records sound.
(4)	Webcam light	On: The webcam is in use.
(5)	Webcam	Records video, captures still photographs, and allows video conferences and online chat by means of streaming video. To use the webcam, select Start > All Programs > Communication and Chat > CyberLink YouCam .

*The antennas are not visible from the outside of the computer. For optimal transmission, keep the areas immediately around the antennas free from obstructions. For wireless regulatory notices, see the section of the *Regulatory, Safety, and Environmental Notices* that applies to your country or region. These notices are located in Help and Support.

Button



Component	Description
(1) Power button	<ul style="list-style-type: none">• When the computer is off, press the button to turn on the computer.• When the computer is on, press the button briefly to initiate Sleep.• When the computer is in the Sleep state, press the button briefly to exit Sleep.• When the computer is in Hibernation, press the button briefly to exit Hibernation. <p>CAUTION: Pressing and holding down the power button will result in the loss of unsaved information.</p> <p>If the computer has stopped responding and Microsoft Windows shutdown procedures are ineffective, press and hold the power button down for at least 5 seconds to turn off the computer.</p> <p>To learn more about your power settings, select Start > Control Panel > System and Security > Power Options.</p>
(2) Speakers (2)	Produce sound.

Keys

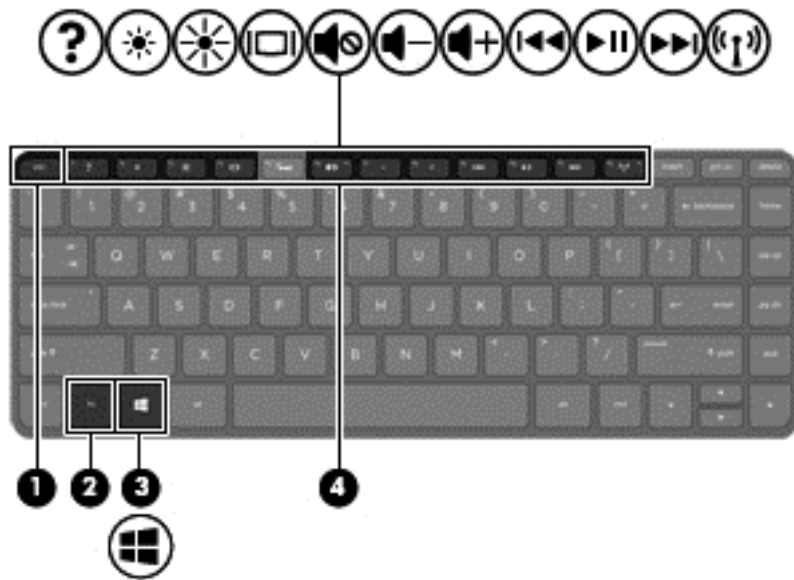

Item	Component	Description
(1)	esc key	Displays system information when pressed in combination with the fn key.
(2)	fn key	Used in conjunction with hot keys.
(3)	Windows logo key	Displays the Windows Start menu.
(4)	Action keys	Execute frequently used system functions.

Lights

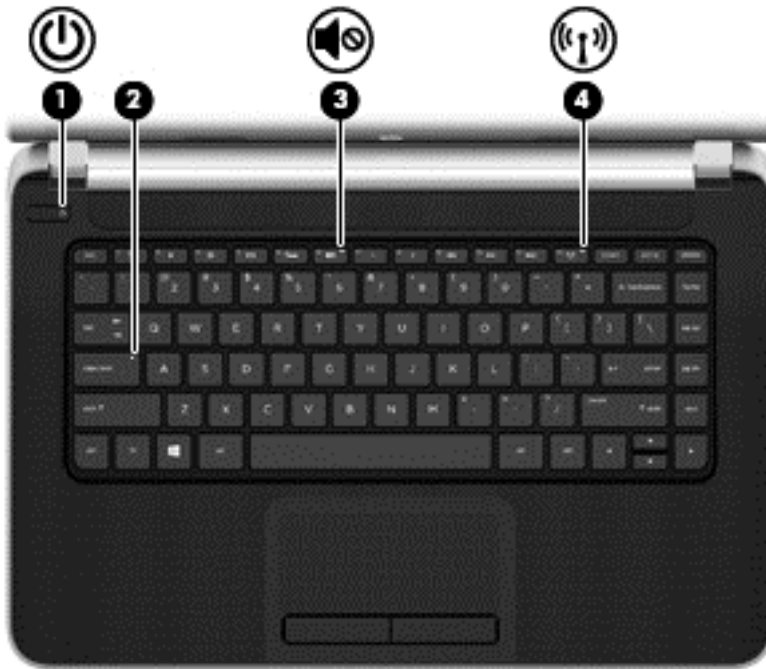

Item	Component	Description
(1)	Power light	<ul style="list-style-type: none">• White: The computer is on.• Blinking white: The computer is in the Sleep state, which is an energy-saving mode. The computer shuts off power to the display and other unneeded components.• Off: The computer is off or in Hibernation. Hibernation is an energy-saving mode that uses the least amount of power.
(2)	Caps lock light	On: Caps lock is on, which switches the keys to all capital letters.
(3)	Mute light	<ul style="list-style-type: none">• Amber: Computer sound is off.• Off: Computer sound is on.
(4)	Wireless light	<ul style="list-style-type: none">• White: An integrated wireless device, such as a WLAN device and/or a Bluetooth device, is on.• Amber: All wireless devices are off.

TouchPad



Item	Component	Description
(1)	TouchPad zone	Moves the on-screen pointer and selects or activates items on the screen. NOTE: The TouchPad also supports edge-swipe gestures.
(2)	Left TouchPad button	Functions like the left button on an external mouse.
(3)	Right TouchPad button	Functions like the right button on an external mouse.

Left side

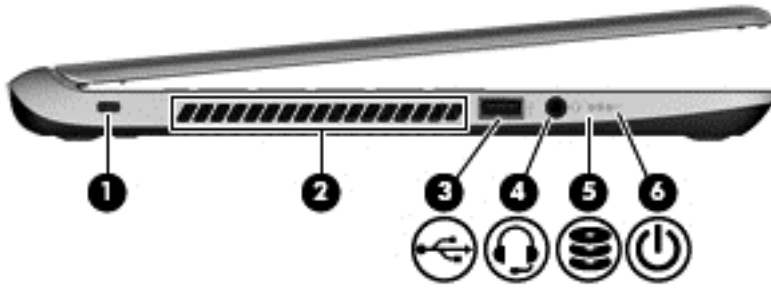

Item	Component	Description
(1)	Security cable slot	Attaches an optional security cable to the computer. NOTE: The security cable is designed to act as a deterrent, but it may not prevent the computer from being mishandled or stolen.
(2)	Vent	Enable airflow to cool internal components. NOTE: The computer fan starts up automatically to cool internal components and prevent overheating. It is normal for the internal fan to cycle on and off during routine operation.
(3)	USB 3.0 port	Connect optional USB 3.0 devices and provide enhanced USB power performance.
(4)	Audio-out (headphone) jack	Connects optional powered stereo speakers, headphones, earbuds, a headset, or a television audio cable. Also connects an optional headset microphone. This jack does not support optional microphone-only devices. WARNING! To reduce the risk of personal injury, adjust the volume before putting on headphones, earbuds, or a headset. For additional safety information, refer to the Regulatory, Safety, and Environmental Notices. To access this guide, from the Start screen, type support, select the HP Support Assistant app, select My computer, and then select User guides. NOTE: When a device is connected to the jack, the computer speakers are disabled. NOTE: Be sure that the device cable has a 4-conductor connector that supports both audio-out (headphone) and audio-in (microphone).

Item	Component	Description
(5)	Hard drive light	<ul style="list-style-type: none">• Blinking white: The hard drive is being accessed.• Amber: HP 3D DriveGuard has temporarily parked the hard drive.
(6)	Power light	<ul style="list-style-type: none">• White: The computer is on.• Blinking white: The computer is in the Sleep state, which is an energy-saving mode. The computer shuts off power to the display and other unneeded components.• Off: The computer is off or in Hibernation. Hibernation is an energy-saving mode that uses the least amount of power. <p>NOTE: For select models, the Intel Rapid Start Technology feature is enabled at the factory. Rapid Start Technology allows your computer to resume quickly from inactivity.</p>

Right side

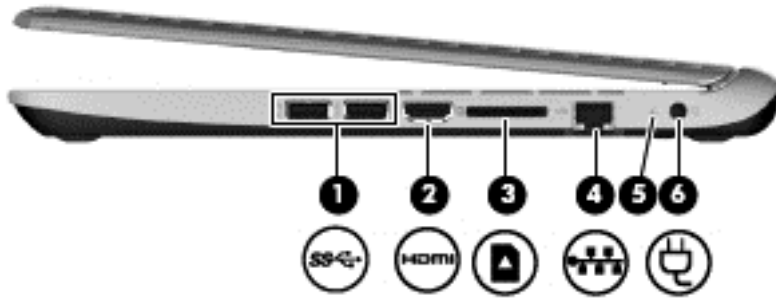

Item	Component	Description
(1)	USB ports	Connects an optional USB device. CAUTION: While there are multiple USB ports on the same side, only one USB port will be able to support a high power device at a time.
(2)	HDMI port	Connects an optional video or audio device, such as a high-definition television, any compatible digital or audio device.
(3)	Memory card reader	Reads data from and writes data to digital memory cards such as Secure Digital (SD). <ul style="list-style-type: none">Memory card reader
(4)	RJ-45 (network) jack	Connects a network cable.
(5)	AC adapter light	<ul style="list-style-type: none">White: The AC adapter is connected and the battery is charged.Amber: The AC adapter is connected and the battery is charging.Off: The computer is using DC power.
(6)	Power connector	Connects an AC adapter.

Bottom

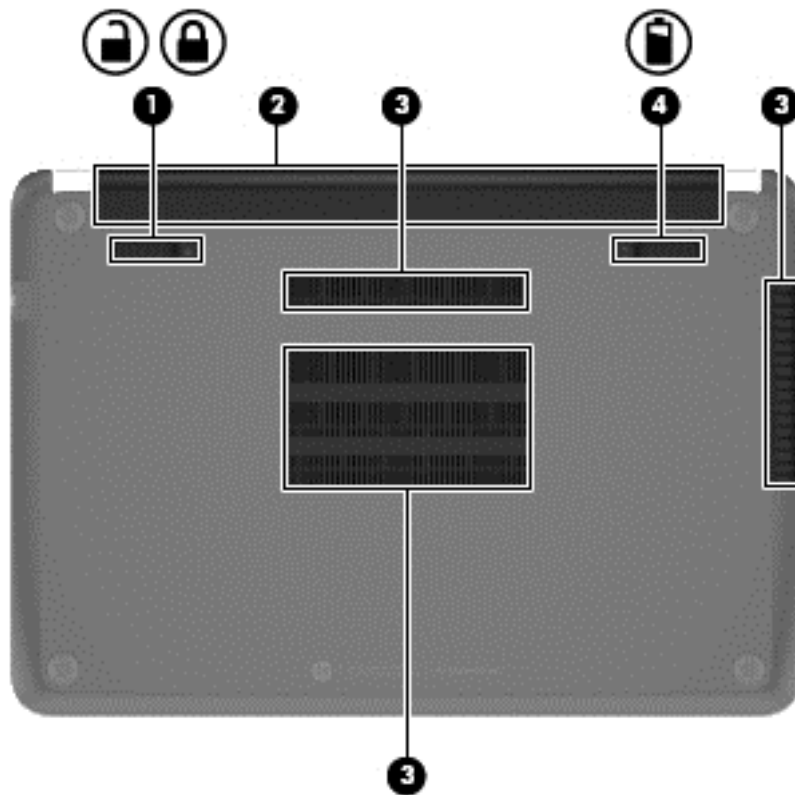

Item	Component	Description
(1)	Battery lock/unlock latch	Locks battery in place
(2)	Battery bay	Holds the battery.
(3)	Vents (3)	Enable airflow to cool internal components. NOTE: The computer fan starts up automatically to cool internal components and prevent overheating. It is normal for the internal fan to cycle on and off during routine operation.
(4)	Battery release latch	Releases the battery from the battery bay.

3 Illustrated parts catalog

Service tag

When ordering parts or requesting information, provide the computer serial number and model description provided on the service tag.

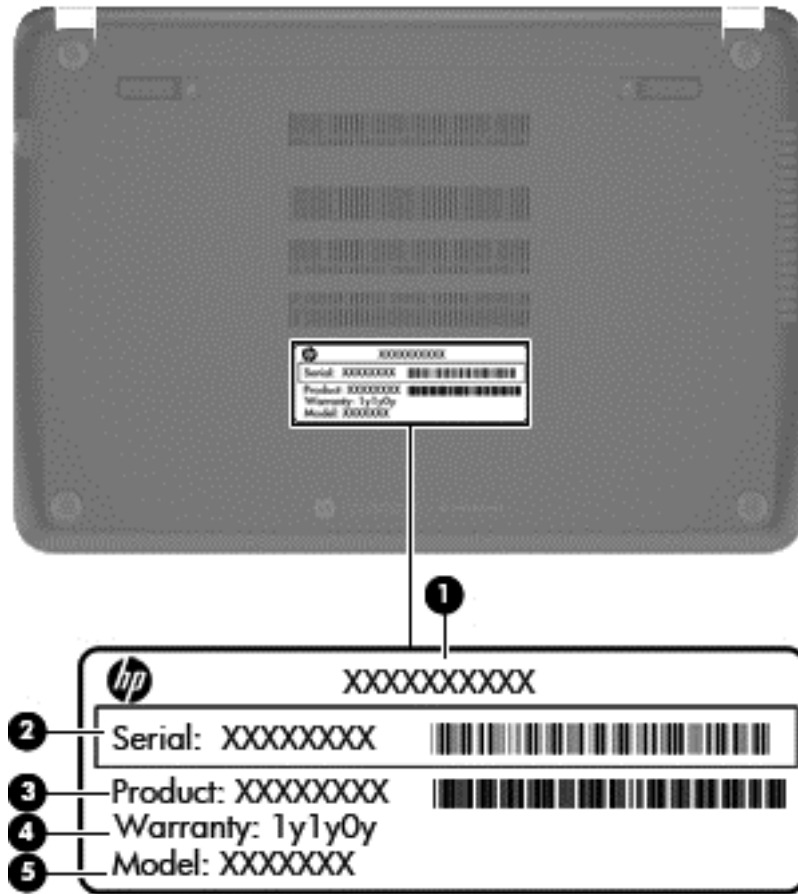

Item	Description	Function
(1)	Product name	This is the product name affixed to the front of the computer.
(2)	Serial number (s/n)	This is an alphanumeric identifier that is unique to each product.
(3)	Part number/Product number (p/n)	This number provides specific information about the product's hardware components. The part number helps a service technician to determine what components and parts are needed.
(4)	Warranty period	This number describes the duration of the warranty period for the computer.
(5)	Model description	This is the alphanumeric identifier used to locate documents, drivers, and support for the computer.

Computer major components

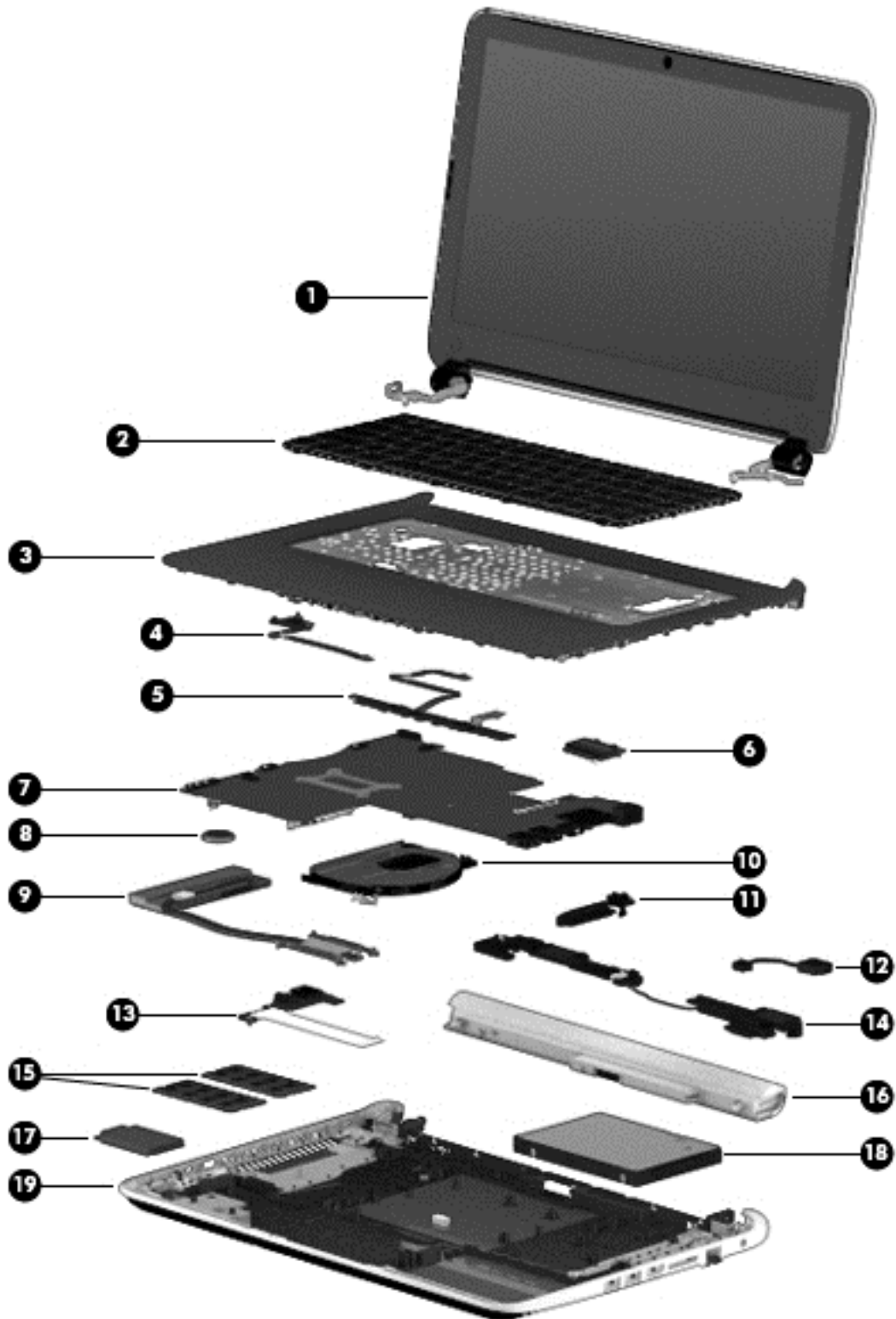

Item	Component	Spare part number
(1)	TouchScreen display assembly (14.0-in, HD, LED, BrightView (1366×768), SVA, slim (3.0-mm))	
	In pearl white finish	732345-001
	In sparkling black finish	726201-001
(2)	Keyboard (includes keyboard cable):	
	For use in United States	716164-001
	For use in Latin America	716164-161
	For use in Canada/England	716164-DB1
	For use in United States	722129-001
	For use in Latin America	722129-161
	For use in England/France	722129-DB1
(3)	Top cover (includes the TouchPad board)	
	In pearl white finish	726209-001
	In sparkling black finish	726210-001
(4)	Power button board (includes cable)	726203-001
(5)	TouchPad button board (includes bracket, TouchPad button board cable, and TouchPad cable)	726202-001
(6)	WLAN module:	
	Atheros AR9485 802.11b/g/n WiFi Adapter for use on all computer models	675794-001
	Ralink RT3290LE 802.11b/g/n 1×1 WiFi and Bluetooth 4.0 Combo Adapter for use on all computer models	690020-001
	Realtek RTL8188EE 802.11bg/n 1×1 WiFi Adapter	709848-001
(7)	System board (includes processor and replacement thermal material):	
	Equipped with an AMD A4-5000 processor (1.50-GHz, 2.00-MB L2 cache, 1600-MHz DDR3L, quad core, 15 W) and the Linux operating system (includes AMD A76M FCH, a graphics subsystem with UMA memory, and replacement thermal material)	727199-001
	Equipped with an AMD A4-5000 processor (1.50-GHz, 2.00-MB L2 cache, 1600-MHz DDR3L, quad core, 15 W) and the Windows 8 Standard operating system (includes AMD A76M FCH, a graphics subsystem with UMA memory, and replacement thermal material)	727199-501
	Equipped with an AMD A6-5200 processor (2.00-GHz, 2.00-MB L2 cache, 1600-MHz DDR3L, quad core, 25 W) and the Linux operating system (includes AMD A76M FCH, a graphics subsystem with UMA memory, and replacement thermal material)	727200-001
	Equipped with an AMD A6-5200 processor (2.00-GHz, 2.00-MB L2 cache, 1600-MHz DDR3L, quad core, 25 W) and the Windows 8 Standard operating system (includes AMD A76M FCH, a graphics subsystem with UMA memory, and replacement thermal material)	727200-501

Item	Component	Spare part number
	Equipped with an AMD A8-5545M processor (2.70-/1.70-GHz, 4.00-MB L2 cache, 1333-MHz DDR3L, quad core, 19 W) and the Linux operating system (includes AMD A76M FCH, a graphics subsystem with UMA memory, and replacement thermal material)	727202-001
	Equipped with an AMD A8-5545M processor (2.70-/1.70-GHz, 4.00-MB L2 cache, 1333-MHz DDR3L, quad core, 19 W) and the Windows 8 Standard operating system (includes AMD A76M FCH, a graphics subsystem with UMA memory, and replacement thermal material)	727202-501
(8)	RTC battery	697917-001
(9)	Heat sink	
	Heat sink for use only on computer models equipped with an AMD-A8, AMD-A4, AMD-E2 processor (includes replacement thermal material)	726214-001
	Heat sink for use only on computer models equipped with an AMD-A6 processor (includes replacement thermal material)	727545-001
(10)	Fan assembly (includes cable)	725620-001
(11)	Hard drive connector cable (Hard Drive Hardware Kit (includes hard drive bracket, hard drive connector cable, and screws)	
(12)	Power connector cable (includes bracket)	725619-001
(13)	USB board (includes cable)	726204-001
(14)	Speakers (include speaker cables)	726208-001
(15)	Memory module (PC3, 12800, 1600-MHz):	
	4-GB memory module	691740-001
	2-GB memory module	691739-001
(16)	4-cell, 41-Wh, 2.80-Ah, Li-ion battery battery	718101-001
(17)	PCH heat sink (includes thermal replacement material)	725625-001
(18)	Hard drive (does not include hard drive bracket, hard drive connector cable, or screws):	
	1-TB, 5400-rpm, 9.5-mm	676521-001
	750-GB, 5400-rpm, 9.5-mm	634250-001
	640-GB, 5400-rpm, 9.5-mm	669300-001
	500-GB, 5400-rpm, 9.5-mm	669299-001
	320-GB, 5400-rpm, 9.5-mm	622643-001
	Hard Drive Hardware Kit (not illustrated, includes hard drive bracket, hard drive connector cable, and screws)	725626-001
(19)	Base enclosure (includes battery cover lock latch, battery cover release latch, power connector barrel, and RJ45 cover):	726198-001
	Rubber Kit (not illustrated, includes front and rear rubber feet, display bezel rubber bumpers, and display bezel rubber screw covers)	726497-001

Mass storage devices



Item	Component	Spare part number
(1)	Hard drive (does not include hard drive bracket, hard drive connector cable, or screws):	
	1-TB, 5400-rpm, 9.5-mm	676521-001
	750-GB, 5400-rpm, 9.5-mm	634250-001
	640-GB, 5400-rpm, 9.5-mm	669300-001
	500-GB, 5400-rpm, 9.5-mm	669299-001
	320-GB, 5400-rpm, 9.5-mm	622643-001
	Hard Drive Hardware Kit , includes:	725626-001
(2a)	Hard drive bracket	
(2b)	Hard drive connector cable	
	Hard drive bracket screws (not illustrated)	
(3)	External DVD±RW Double-Layer with SuperMulti Drive	659940-001

Miscellaneous parts

Component	Spare part number
65-W HP Smart AC adapter (non-PFC, 4.5-mm)	710412-001
Power cord (3-pin, black, 1.83-m):	
For use in North America	490371-001
For use in Italy	490371-061
Screw Kit	726208-001

Sequential part number listing

Spare part number	Description
490371-001	Power cord for use in North America (3-pin, black, 1.83-m)
490371-061	Power cord for use in Italy (3-pin, black, 1.83-m)
622643-001	320-GB, 5400-rpm, 9.5-mm hard drive (does not include hard drive bracket, hard drive connector cable, or screws) NOTE: The hard drive bracket, hard drive connector cable, and screws are included in the Hard Drive Hardware Kit, spare part number 725626-001.
634250-001	750-GB, 5400-rpm, 9.5-mm hard drive (does not include hard drive bracket, hard drive connector cable, or screws) NOTE: The hard drive bracket, hard drive connector cable, and screws are included in the Hard Drive Hardware Kit, spare part number 725626-001.
659940-001	External DVD±RW Double-Layer with SuperMulti Drive
669299-001	500-GB, 5400-rpm, 9.5-mm hard drive (does not include hard drive bracket, hard drive connector cable, or screws) NOTE: The hard drive bracket, hard drive connector cable, and screws are included in the Hard Drive Hardware Kit, spare part number 725626-001.
669300-001	640-GB, 5400-rpm, 9.5-mm hard drive (does not include hard drive bracket, hard drive connector cable, or screws) NOTE: The hard drive bracket, hard drive connector cable, and screws are included in the Hard Drive Hardware Kit, spare part number 725626-001.
675794-001	Atheros AR9485 802.11b/g/n WiFi Adapter for use on all computer models
676521-001	1-TB, 5400-rpm, 9.5-mm hard drive (does not include hard drive bracket, hard drive connector cable, or screws) NOTE: The hard drive bracket, hard drive connector cable, and screws are included in the Hard Drive Hardware Kit, spare part number 725626-001.
690020-001	Ralink RT3290LE 802.11b/g/n 1×1 WiFi and Bluetooth 4.0 Combo Adapter

Spare part number	Description
691739-001	2-GB memory module (PC3, 12800, 1600-MHz)
691740-001	4-GB memory module (PC3, 12800, 1600-MHz)
697917-001	RTC battery (includes cable and double-sided tape)
701943-001	HDMI to VGA adapter
709848-001	Realtek RTL8188EE 802.11b/g/n 1x1 WiFi Adapter
710412-001	65-W HP Smart AC adapter (non-PFC, 4.5-mm)
716164-001	Keyboard for use in United States (includes keyboard cable)
716164-161	Keyboard for use in Latin America (includes keyboard cable)
716164-DB1	Keyboard for use in Canada/England (includes keyboard cable)
718101-001	4-cell, 41-Wh, 2.80-Ah, Li-ion battery
722129-001	Keyboard for use in United States (includes keyboard cable)
722129-161	Keyboard for use in Latin America (includes keyboard cable).
722129-DB1	Keyboard for use in England/France (includes keyboard cable).
725619-001	Power connector cable
725620-001	Fan (includes cable)
725625-001	PCH heat sink (includes thermal replacement material)
725626-001	Hard Drive Hardware Kit (includes hard drive bracket, hard drive connector cable, and screws)
725659-001	Thermal Material Kit (includes thermal replacement material)
726198-001	Base enclosure (includes battery cover lock latch, battery cover release latch, power connector barrel, and RJ45 cover)
726199-001	Dummy weight
726201-001	14.0-in, HD, LED, BrightView (1366x768), slim (3.0-mm), SVA, TouchScreen display assembly in sparkling black finish
726202-001	TouchPad button board (includes bracket, TouchPad button board cable, and TouchPad cable)
726203-001	Power button board (includes cable)
726204-001	USB board (includes cable)
726207-001	Screw Kit
726208-001	Speakers (include speaker cables)
726209-001	Top cover in pearl white finish (includes TouchPad)
726210-001	Top cover in sparkling black finish (includes TouchPad)
726214-001	Heat sink for use only on computer models equipped with an AMD-A8, AMD-A4, AMD-E2 processor (includes replacement thermal material)
726497-001	Rubber Kit (includes front and rear rubber feet, display bezel rubber bumpers, and display bezel rubber screw covers)

Spare part number	Description
727199-001	System board for use only on computer models equipped with an AMD A4-5000 processor (1.50-GHz, 2.00-MB L2 cache, 1600-MHz DDR3L, quad core, 15 W) and the Linux operating system (includes AMD A76M FCH, a graphics subsystem with UMA memory, and replacement thermal material)
727199-501	System board for use only on computer models equipped with an AMD A4-5000 processor (1.50-GHz, 2.00-MB L2 cache, 1600-MHz DDR3L, quad core, 15 W) and the Windows 8 Standard operating system (includes AMD A76M FCH, a graphics subsystem with UMA memory, and replacement thermal material)
727200-001	System board for use only on computer models equipped with an AMD A6-5200 processor (2.00-GHz, 2.00-MB L2 cache, 1600-MHz DDR3L, quad core, 25 W) and the Linux operating system (includes AMD A76M FCH, a graphics subsystem with UMA memory, and replacement thermal material)
727200-501	System board for use only on computer models equipped with an AMD A6-5200 processor (2.00-GHz, 2.00-MB L2 cache, 1600-MHz DDR3L, quad core, 25 W) and the Windows 8 Standard operating system (includes AMD A76M FCH, a graphics subsystem with UMA memory, and replacement thermal material)
727202-001	System board for use only on computer models equipped with an AMD A8-5545M processor (2.70-/1.70-GHz, 4.00-MB L2 cache, 1333-MHz DDR3L, quad core, 19 W) and the Linux operating system (includes AMD A76M FCH, a graphics subsystem with UMA memory, and replacement thermal material)
727202-501	System board for use only on computer models equipped with an AMD A8-5545M processor (2.70-/1.70-GHz, 4.00-MB L2 cache, 1333-MHz DDR3L, quad core, 19 W) and the Windows 8 Standard operating system (includes AMD A76M FCH, a graphics subsystem with UMA memory, and replacement thermal material)
727545-001	Heat sink for use only on computer models equipped with an AMD-A6 processor (includes replacement thermal material)
732345-001	14.0-in, HD, LED, BrightView (1366×768), slim (3.0-mm), SVA, TouchScreen display assembly in pearl white finish

4 Removal and replacement procedures preliminary requirements

Tools required

You will need the following tools to complete the removal and replacement procedures:

- Flat-bladed screw driver
- Magnetic screw driver
- Phillips P0 and P1 screw drivers

Service considerations

The following sections include some of the considerations that you must keep in mind during disassembly and assembly procedures.



NOTE: As you remove each subassembly from the computer, place the subassembly (and all accompanying screws) away from the work area to prevent damage.

Plastic parts



CAUTION: Using excessive force during disassembly and reassembly can damage plastic parts. Use care when handling the plastic parts. Apply pressure only at the points designated in the maintenance instructions.

Cables and connectors

⚠ CAUTION: When servicing the computer, be sure that cables are placed in their proper locations during the reassembly process. Improper cable placement can damage the computer.

Cables must be handled with extreme care to avoid damage. Apply only the tension required to unseat or seat the cables during removal and insertion. Handle cables by the connector whenever possible. In all cases, avoid bending, twisting, or tearing cables. Be sure that cables are routed in such a way that they cannot be caught or snagged by parts being removed or replaced. Handle flex cables with extreme care; these cables tear easily.

Drive handling

⚠ CAUTION: Drives are fragile components that must be handled with care. To prevent damage to the computer, damage to a drive, or loss of information, observe these precautions:

Before removing or inserting a hard drive, shut down the computer. If you are unsure whether the computer is off or in Hibernation, turn the computer on, and then shut it down through the operating system.

Before handling a drive, be sure that you are discharged of static electricity. While handling a drive, avoid touching the connector.

Before removing a diskette drive or optical drive, be sure that a diskette or disc is not in the drive and be sure that the optical drive tray is closed.

Handle drives on surfaces covered with at least one inch of shock-proof foam.

Avoid dropping drives from any height onto any surface.

After removing a hard drive, an optical drive, or a diskette drive, place it in a static-proof bag.

Avoid exposing an internal hard drive to products that have magnetic fields, such as monitors or speakers.

Avoid exposing a drive to temperature extremes or liquids.

If a drive must be mailed, place the drive in a bubble pack mailer or other suitable form of protective packaging and label the package "FRAGILE."

Grounding guidelines

Electrostatic discharge damage

Electronic components are sensitive to electrostatic discharge (ESD). Circuitry design and structure determine the degree of sensitivity. Networks built into many integrated circuits provide some protection, but in many cases, ESD contains enough power to alter device parameters or melt silicon junctions.

A discharge of static electricity from a finger or other conductor can destroy static-sensitive devices or microcircuitry. Even if the spark is neither felt nor heard, damage may have occurred.

An electronic device exposed to ESD may not be affected at all and can work perfectly throughout a normal cycle. Or the device may function normally for a while, then degrade in the internal layers, reducing its life expectancy.

⚠ CAUTION: To prevent damage to the computer when you are removing or installing internal components, observe these precautions:

Keep components in their electrostatic-safe containers until you are ready to install them.

Before touching an electronic component, discharge static electricity by using the guidelines described in this section.

Avoid touching pins, leads, and circuitry. Handle electronic components as little as possible.

If you remove a component, place it in an electrostatic-safe container.

The following table shows how humidity affects the electrostatic voltage levels generated by different activities.

⚠ CAUTION: A product can be degraded by as little as 700 V.

Typical electrostatic voltage levels			
Event	Relative humidity		
	10%	40%	55%
Walking across carpet	35,000 V	15,000 V	7,500 V
Walking across vinyl floor	12,000 V	5,000 V	3,000 V
Motions of bench worker	6,000 V	800 V	400 V
Removing DIPS from plastic tube	2,000 V	700 V	400 V
Removing DIPS from vinyl tray	11,500 V	4,000 V	2,000 V
Removing DIPS from Styrofoam	14,500 V	5,000 V	3,500 V
Removing bubble pack from PCB	26,500 V	20,000 V	7,000 V
Packing PCBs in foam-lined box	21,000 V	11,000 V	5,000 V

Packaging and transporting guidelines

Follow these grounding guidelines when packaging and transporting equipment:

- To avoid hand contact, transport products in static-safe tubes, bags, or boxes.
- Protect ESD-sensitive parts and assemblies with conductive or approved containers or packaging.
- Keep ESD-sensitive parts in their containers until the parts arrive at static-free workstations.
- Place items on a grounded surface before removing items from their containers.
- Always be properly grounded when touching a component or assembly.
- Store reusable ESD-sensitive parts from assemblies in protective packaging or nonconductive foam.
- Use transporters and conveyors made of antistatic belts and roller bushings. Be sure that mechanized equipment used for moving materials is wired to ground and that proper materials are selected to avoid static charging. When grounding is not possible, use an ionizer to dissipate electric charges.

Workstation guidelines

Follow these grounding workstation guidelines:

- Cover the workstation with approved static-shielding material.
- Use a wrist strap connected to a properly grounded work surface and use properly grounded tools and equipment.
- Use conductive field service tools, such as cutters, screw drivers, and vacuums.
- When fixtures must directly contact dissipative surfaces, use fixtures made only of static-safe materials.
- Keep the work area free of nonconductive materials, such as ordinary plastic assembly aids and Styrofoam.
- Handle ESD-sensitive components, parts, and assemblies by the case or PCM laminate. Handle these items only at static-free workstations.
- Avoid contact with pins, leads, or circuitry.
- Turn off power and input signals before inserting or removing connectors or test equipment.

Equipment guidelines

Grounding equipment must include either a wrist strap or a foot strap at a grounded workstation.

- When seated, wear a wrist strap connected to a grounded system. Wrist straps are flexible straps with a minimum of one megohm $\pm 10\%$ resistance in the ground cords. To provide proper ground, wear a strap snugly against the skin at all times. On grounded mats with banana-plug connectors, use alligator clips to connect a wrist strap.
- When standing, use foot straps and a grounded floor mat. Foot straps (heel, toe, or boot straps) can be used at standing workstations and are compatible with most types of shoes or boots. On conductive floors or dissipative floor mats, use foot straps on both feet with a minimum of one megohm resistance between the operator and ground. To be effective, the conductive must be worn in contact with the skin.

The following grounding equipment is recommended to prevent electrostatic damage:

- Antistatic tape
- Antistatic smocks, aprons, and sleeve protectors
- Conductive bins and other assembly or soldering aids
- Nonconductive foam
- Conductive tabletop workstations with ground cords of one megohm resistance
- Static-dissipative tables or floor mats with hard ties to the ground
- Field service kits
- Static awareness labels
- Material-handling packages
- Nonconductive plastic bags, tubes, or boxes
- Metal tote boxes
- Electrostatic voltage levels and protective materials

The following table lists the shielding protection provided by antistatic bags and floor mats.

Material	Use	Voltage protection level
Antistatic plastics	Bags	1,500 V
Carbon-loaded plastic	Floor mats	7,500 V
Metallized laminate	Floor mats	5,000 V

5 Removal and replacement procedures for Customer Self-Repair parts

 **NOTE:** The Customer Self-Repair program is not available in all locations. Installing a part not supported by the Customer Self-Repair program may void your warranty. Check your warranty to determine if Customer Self-Repair is supported in your location.

Component replacement procedures

 **NOTE:** Please read and follow the procedures described here to access and replace Customer Self-Repair parts successfully.

 **NOTE:** Details about your computer, including model, serial number, product key, and length of warranty, are on the service tag at the bottom of your computer. See Service tag on page 16 for details.

This chapter provides removal and replacement procedures for Customer Self-Repair parts.

There are as many as 2 screws that must be removed, replaced, and/or loosened when servicing Customer Self-Repair parts. Make special note of each screw size and location during removal and replacement.

Battery

Description	Spare part number
4-cell, 41-Wh, 2.80-Ah, Li-ion battery	718101-001

Before removing the battery, follow these steps:

1. Turn off the computer. If you are unsure whether the computer is off or in Hibernation, turn the computer on, and then shut it down through the operating system.
2. Disconnect the power from the computer by unplugging the power cord from the computer.
3. Disconnect all external devices from the computer.

Remove the battery:

WARNING! To reduce potential safety issues, use only the user-replaceable battery provided with the computer, a replacement battery provided by HP, or a compatible battery purchased from HP.

CAUTION: Removing a user-replaceable battery that is the sole power source for the computer can cause loss of information. To prevent loss of information, save your work or shut down the computer through Windows before removing the battery.

1. Turn the computer upside down on a flat surface.
2. Slide the battery lock latch **(1)** to unlock the battery.

NOTE: The battery release latch automatically returns to its original position after the battery is removed.

3. Slide the battery release latch **(2)** to release the battery.
4. Remove the battery **(3)** from the computer.



Reverse this procedure to install the battery.

Keyboard

 **NOTE:** The keyboard spare part kit includes the keyboard cable.

For use in country/region	Spare part number	For use in country/region	Spare part number
For use in the United States	716164-001	For use in the United States	722129-001
For use in Latin America	716164-161	For use in Latin America	722129-161
For use in Canada/England	716164-DB1	For use in England/France	722129-DB1

Before removing the keyboard, follow these steps:

1. Turn off the computer. If you are unsure whether the computer is off or in Hibernation, turn the computer on, and then shut it down through the operating system.
2. Disconnect the power from the computer by unplugging the power cord from the computer.
3. Disconnect all external devices from the computer.
4. Remove the battery (see [Battery on page 30](#)).

Remove the keyboard:

1. Turn the computer upside down on a flat surface with the back toward you. Remove the two Phillips PM2.5×5.6 screws that secure the keyboard to the computer.

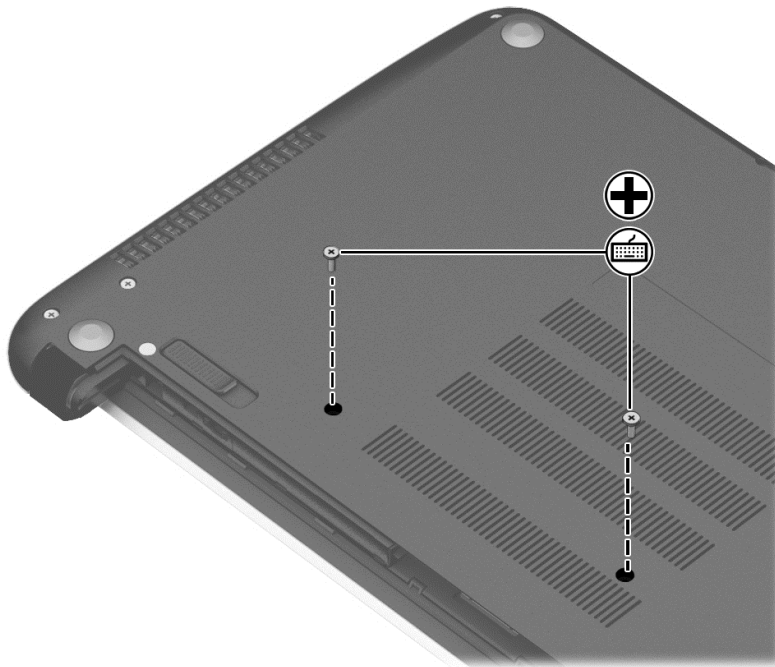

2. Turn the computer right-side up with the front toward you.
3. Lift the rear edge of the keyboard **(1)** until it rests at an angle.

4. Release the keyboard **(2)** by sliding toward the display assembly.

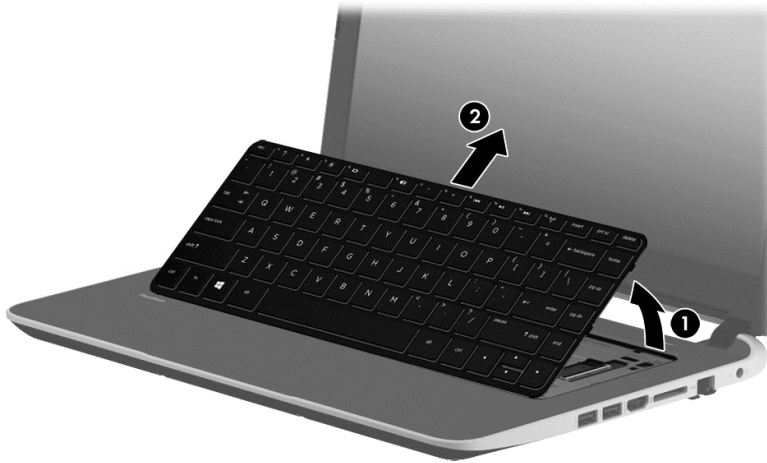

5. Swing the keyboard **(1)** up and forward until it rests upside down on the palm rest.
6. Release the zero insertion force (ZIF) connector **(2)** to which the keyboard cable is attached, and then disconnect the keyboard cable **(3)** from the system board.

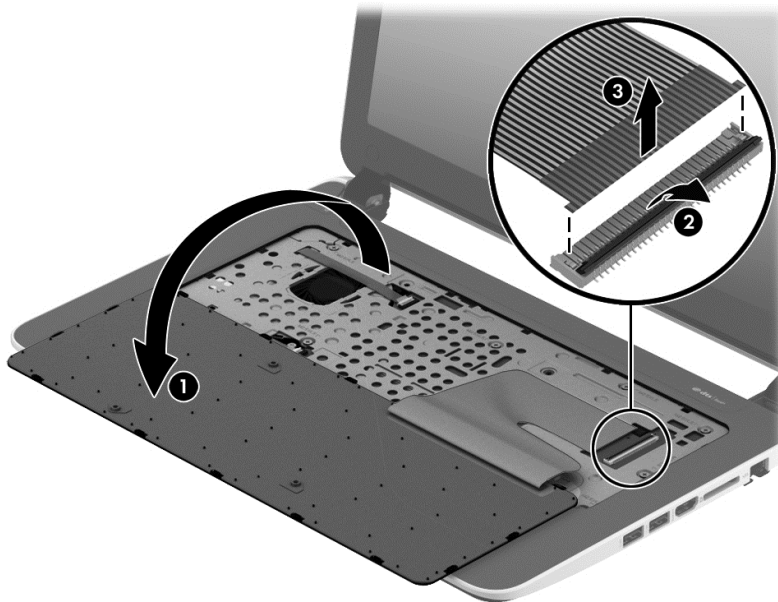

7. Remove the keyboard.

Reverse this procedure to install the keyboard.

6 Removal and replacement procedures for Authorized Service Provider parts

⚠ CAUTION: Components described in this chapter should only be accessed by an authorized service provider. Accessing these parts can damage the computer or void the warranty.

Component replacement procedures

This chapter provides removal and replacement procedures for Authorized Service Provider only parts.

There are as many as 42 screws that must be removed, replaced, and/or loosened when servicing the computer. Make special note of each screw size and location during removal and replacement.

Top cover

Description	Spare part number
In pearl white finish	726909-001
In sparkling black finish	726210-001

Before removing the top cover, follow these steps:

1. Turn off the computer. If you are unsure whether the computer is off or in Hibernation, turn the computer on, and then shut it down through the operating system.
2. Disconnect the power from the computer by unplugging the power cord from the computer.
3. Disconnect all external devices from the computer.
4. Remove the battery (see [Battery on page 30](#)).
5. Remove the keyboard (see [Keyboard on page 31](#)).

 **NOTE:** When replacing the top cover, be sure to remove the following components from the defective top cover and install them on the replacement top cover:

- Power button board (see [Power button board on page 36](#))
- TouchPad button board (see [TouchPad button board on page 37](#))

Remove the top cover:

1. Remove the eight Phillips PM2.5×5.6 screws that secure the top cover to the computer.

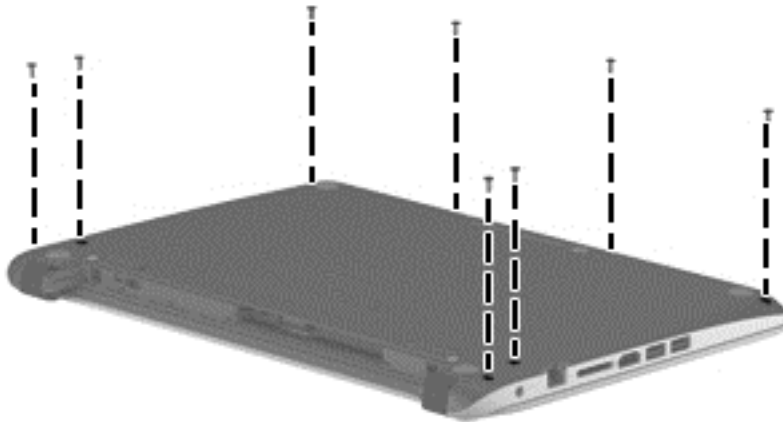

2. Remove the ten screws located on the top cover.

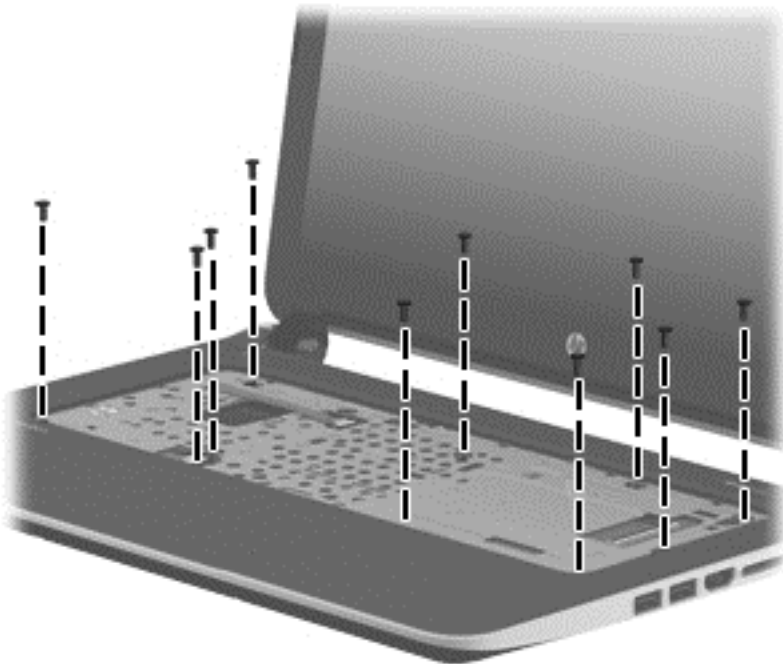

3. Release the ZIF connector (**1**) to which the power button board ribbon cable is connected, and then disconnect the power button board ribbon cable from the system board.

4. Release the ZIF connector **(2)** to which the TouchPad button board ribbon cable is connected, and then disconnect the TouchPad button board ribbon cable from the system board.

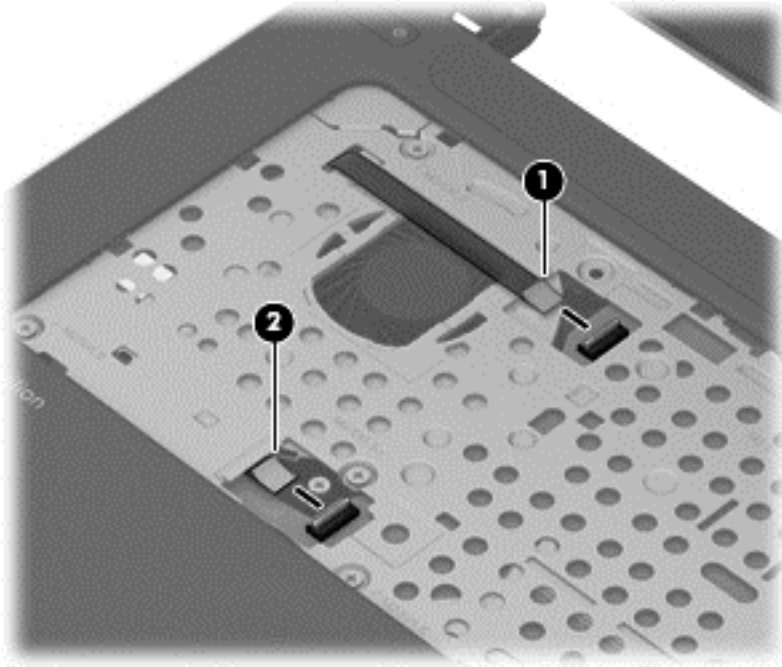

5. Lift the rear edge of the top cover and swing it up and forward **(1)** until the left and right sides of the top cover detach from the base enclosure.
6. Remove the top cover **(2)**.

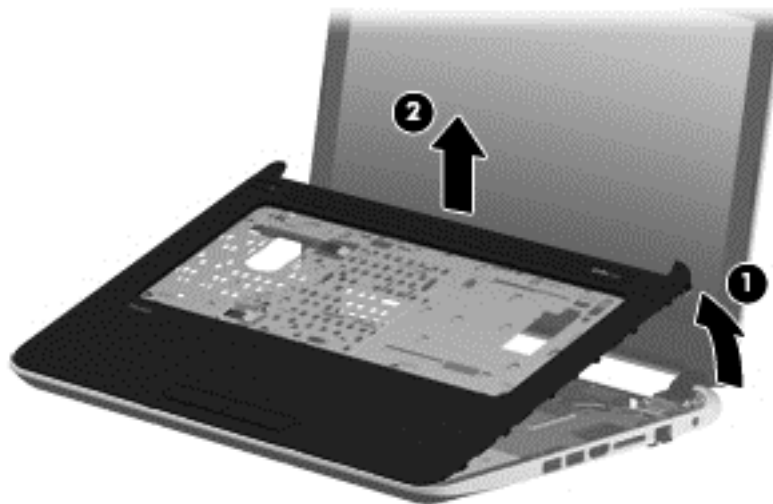

Reverse this procedure to install the top cover.

Power button board

Description	Spare part number
Power button board (includes cable)	722908-001

Before removing the power button board, follow these steps:

1. Turn off the computer. If you are unsure whether the computer is off or in Hibernation, turn the computer on, and then shut it down through the operating system.
2. Disconnect the power from the computer by unplugging the power cord from the computer.
3. Disconnect all external devices from the computer.
4. Remove the battery (see [Battery on page 30](#)).
5. Remove the keyboard (see [Keyboard on page 31](#)).
6. Remove the top cover (see [Top cover on page 33](#)).

Remove the power button board:

1. Turn the top cover upside down, with the front toward you.
2. Remove the two Phillips PM2.0×2.78 screws **(1)** that secure the power button board to the top cover.
3. Release the power button board ribbon cable **(2)** from the top cover. (The power button board cable is attached to the top cover with double-sided tape.)
4. Remove the power button board and cable **(3)**.

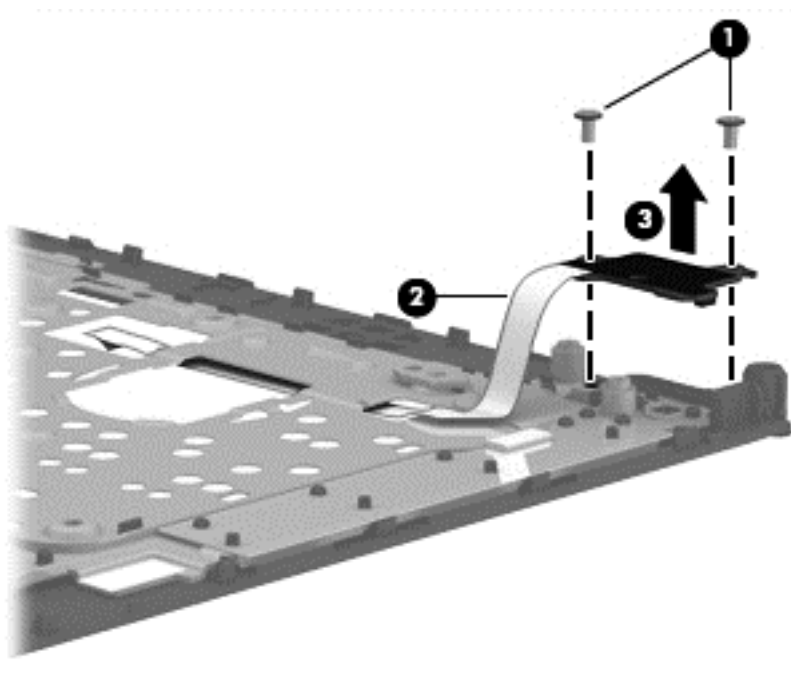

Reverse this procedure to install the power button board.

TouchPad button board

Description	Spare part number
TouchPad button board (includes bracket, TouchPad button board cable, and TouchPad cable)	722909-001

Before removing the TouchPad button board, follow these steps:

1. Turn off the computer. If you are unsure whether the computer is off or in Hibernation, turn the computer on, and then shut it down through the operating system.
2. Disconnect the power from the computer by unplugging the power cord from the computer.
3. Disconnect all external devices from the computer.
4. Remove the battery (see [Battery on page 30](#)).
5. Remove the keyboard (see [Keyboard on page 31](#)).
6. Remove the top cover (see [Top cover on page 33](#)).

Remove the TouchPad button board:

1. Turn the top cover upside down, with the front toward you.
2. Release the ZIF connector **(1)** to which the TouchPad board cable is connected, and then disconnect the TouchPad board cable from the TouchPad board.
3. Detach the TouchPad button board cable **(2)** from the TouchPad. (The TouchPad button board cable is attached to the TouchPad with double-sided tape.)
4. Remove the three screws **(3)** that secure the TouchPad button board to the top cover.

5. Remove the TouchPad button board (4).

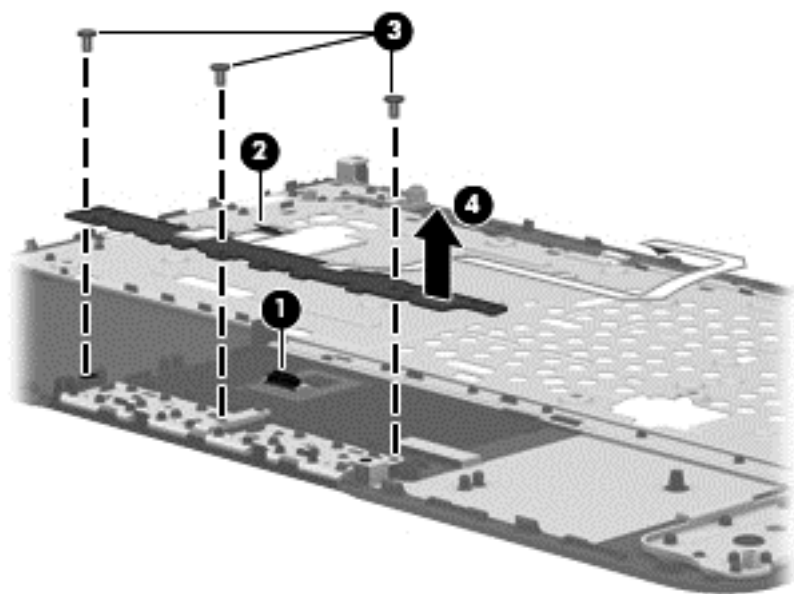

Reverse this procedure to install the TouchPad button board.

Hard drive

 **NOTE:** The hard drive spare part kit does not include the hard drive bracket, hard drive connector cable, and screws. These components are included in the Hard Drive Hardware Kit, spare part number 725626-001.

Description	Spare part number
1-TB, 5400-rpm, 9.5-mm	676521-001
750-GB, 5400-rpm, 9.5-mm	634250-001
640-GB, 5400-rpm, 9.5-mm	669300-001
500-GB, 5400-rpm, 9.5-mm	669299-001
320-GB, 5400-rpm, 9.5-mm	622643-001

Before removing the hard drive, follow these steps:

1. Turn off the computer. If you are unsure whether the computer is off or in Hibernation, turn the computer on, and then shut it down through the operating system.
2. Disconnect the power from the computer by unplugging the power cord from the computer.
3. Disconnect all external devices from the computer.
4. Remove the battery (see [Battery on page 30](#)).

5. Remove the keyboard (see [Keyboard on page 31](#)).
6. Remove the top cover (see [Top cover on page 33](#)).

Remove the hard drive:

1. Lift up on the right side of the hard drive **(1)** until the hard drive rests at an angle.
2. Slide the hard drive **(2)** to the right until it disconnects from the hard drive connector **(3)**.

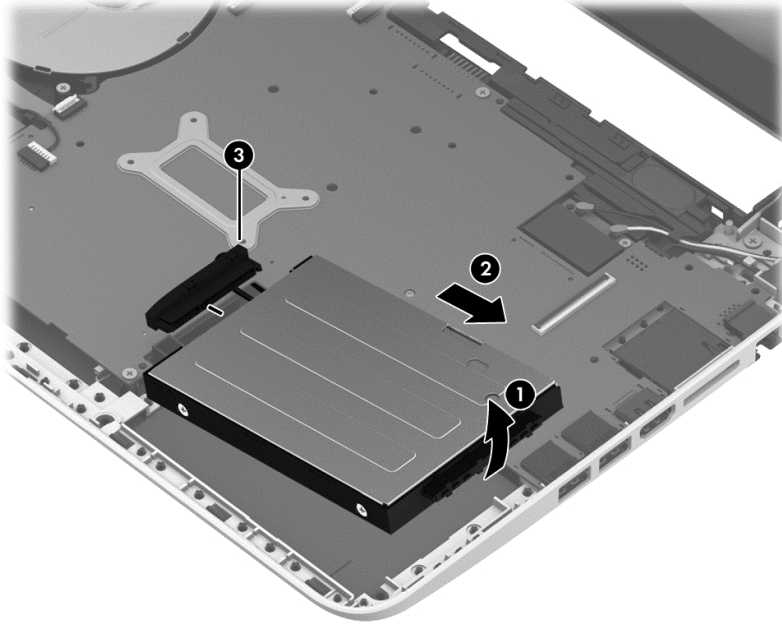

3. Remove the hard drive.
4. If it is necessary to disassemble the hard drive, perform the following steps:
 - a. Position the hard drive with the connector toward you.
 - b. Remove the four Phillips PM3.0×3.73 screws **(1)** that secure the hard drive bracket to the hard drive.
 - c. Remove the hard drive bracket **(2)** from the hard drive.

The hard drive bracket, hard drive connector cable, and screws are available in the Hard Drive Hardware Kit, spare part number 725626-001.

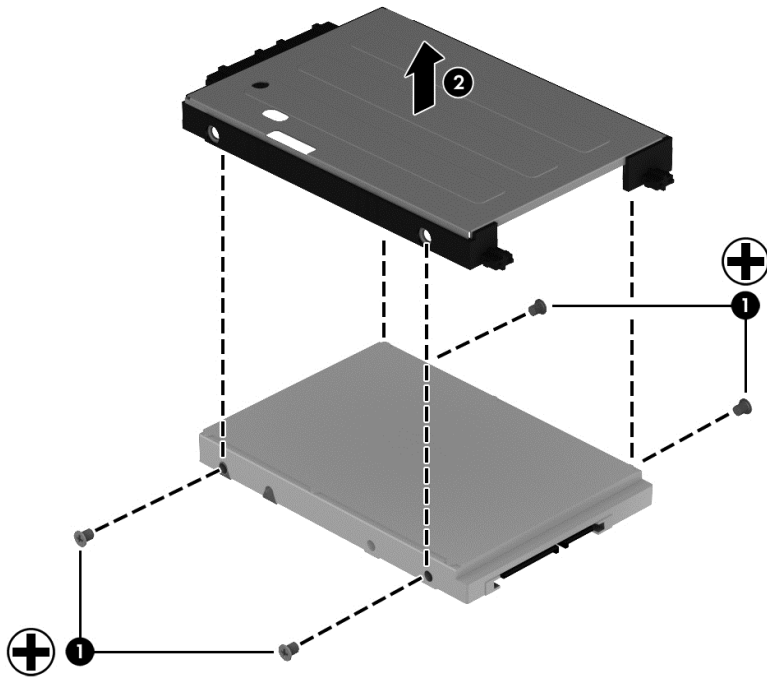

Reverse this procedure to install the hard drive.

USB board

Description	Spare part number
USB board (includes cable)	726204-001

Before removing the USB board, follow these steps:

1. Turn off the computer. If you are unsure whether the computer is off or in Hibernation, turn the computer on, and then shut it down through the operating system.
2. Disconnect the power from the computer by unplugging the power cord from the computer.
3. Disconnect all external devices from the computer.
4. Remove the battery (see [Battery on page 30](#)).
5. Remove the keyboard (see [Keyboard on page 31](#)).
6. Remove the top cover (see [Top cover on page 33](#)).

Remove the USB board:

1. Release the ZIF connector **(1)** to which the USB cable is attached, and then disconnect the USB cable from the system board.
2. Remove Phillips PM2.5×5.6 screw **(2)** that secures the USB board to the base enclosure.
3. Remove the USB board **(3)** and cable.

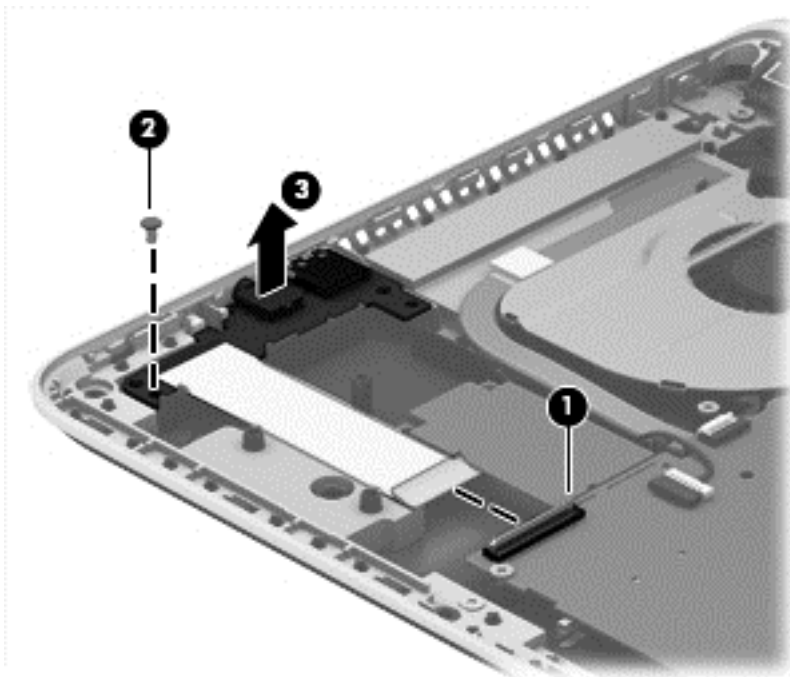

Reverse this procedure to install the USB board.

Fan

Description	Spare part number
Fan (includes cable)	725620-001

Before removing the fan, follow these steps:

1. Turn off the computer. If you are unsure whether the computer is off or in Hibernation, turn the computer on, and then shut it down through the operating system.
2. Disconnect the power from the computer by unplugging the power cord from the computer.
3. Disconnect all external devices from the computer.
4. Remove the battery (see [Battery on page 30](#)).
5. Remove the keyboard (see [Keyboard on page 31](#)).
6. Remove the top cover (see [Top cover on page 33](#)).

Remove the fan:

1. Turn the system board upside down with the front toward you.
2. Disconnect the fan cable **(1)** from the system board.
3. Release the fan cable **(2)** from beneath heat sink pipe.
4. Remove the Phillips PM2.5×5.6 screw **(3)** that secures the fan to the system board.
5. Release the fan **(4)** by lifting the rear edge of the fan.

6. Remove the fan (5).

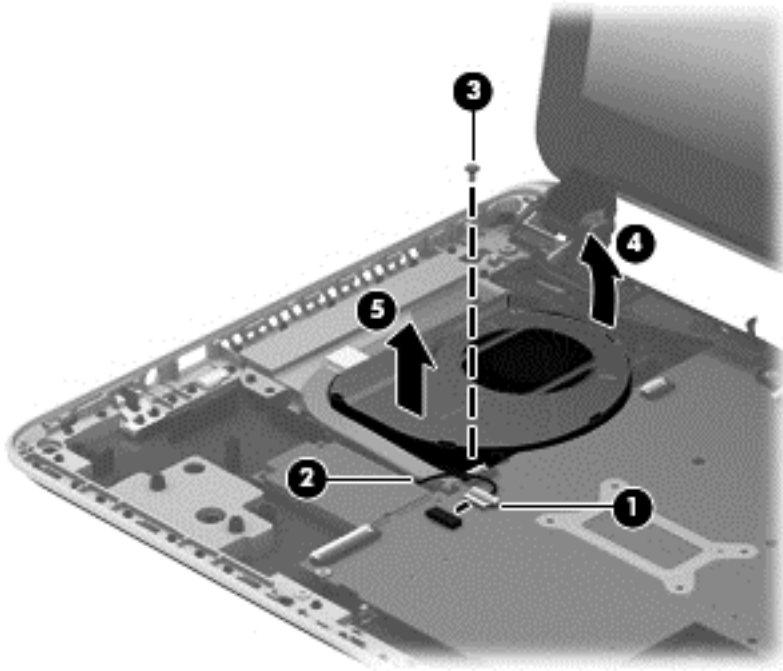

Reverse this procedure to install the fan.

WLAN module

Description	Spare part number
Atheros AR9485 802.11b/g/n WiFi Adapter for use on all computer models	675794-001
Ralink RT3290LE 802.11b/g/n 1×1 WiFi and Bluetooth 4.0 Combo Adapter for use on all computer models	690020-001
Realtek RTL8188EE 802.11bgn Wi-Fi Adapter for use on all computer models	709848-001

 **CAUTION:** To prevent an unresponsive system, replace the wireless module only with a wireless module authorized for use in the computer by the governmental agency that regulates wireless devices in your country or region. If you replace the module and then receive a warning message, remove the module to restore device functionality, and then contact technical support.

Before removing the WLAN module, follow these steps:

1. Turn off the computer. If you are unsure whether the computer is off or in Hibernation, turn the computer on, and then shut it down through the operating system.
2. Disconnect the power from the computer by unplugging the power cord from the computer.
3. Disconnect all external devices from the computer.
4. Remove the battery (see [Battery on page 30](#)).
5. Remove the keyboard (see [Keyboard on page 31](#)).
6. Remove the top cover (see [Top cover on page 33](#)).

Remove the WLAN module:

1. Disconnect the WLAN antenna cables **(1)** from the terminals on the WLAN module.

 **NOTE:** The WLAN antenna cable labeled “1” connects to the WLAN module “Main” terminal labeled “1”. The WLAN antenna cable labeled “2” connects to the WLAN module “Aux” terminal labeled “2”.

2. Remove the Phillips PM2.0×3.58 screw **(2)** that secures the WLAN module to the system board. (The WLAN module tilts up.)

3. Remove the WLAN module (3) by pulling the module away from the slot at an angle.

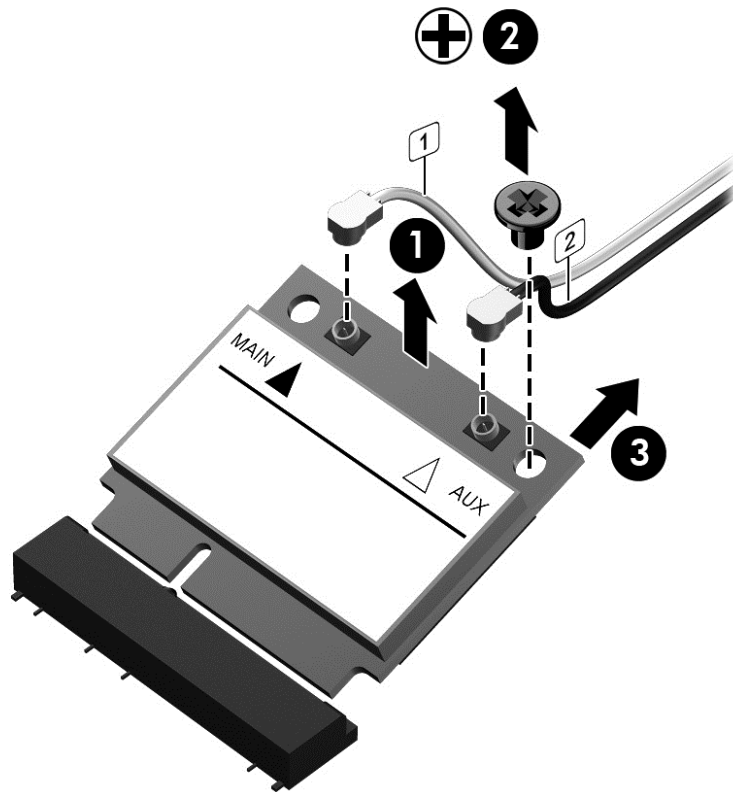

 **NOTE:** If the WLAN antenna cables are not connected to the terminals on the WLAN module, the protective sleeves should be installed on the antenna connectors, as shown in the following illustration.

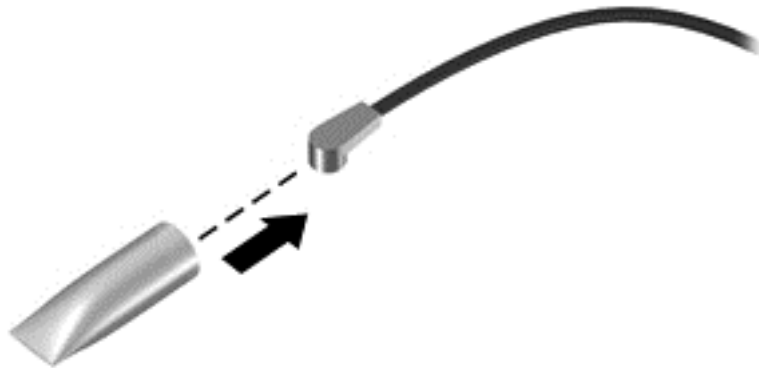

Reverse this procedure to install the WLAN module.

Display assembly

Description	Spare part number
TouchScreen display assembly (14.0-in, HD, LED, BrightView (1366×768), SVA, slim (3.0-mm) in pearl white finish	732345-001
TouchScreen display assembly (14.0-in, HD, LED, BrightView (1366×768), SVA, slim (3.0-mm) in sparkling black finish	726201-001

Before removing the display assembly, follow these steps:

1. Turn off the computer. If you are unsure whether the computer is off or in Hibernation, turn the computer on, and then shut it down through the operating system.
2. Disconnect the power from the computer by unplugging the power cord from the computer.
3. Disconnect all external devices from the computer.
4. Remove the battery (see [Battery on page 30](#)).
5. Remove the keyboard (see [Keyboard on page 31](#)).
6. Remove the top cover (see [Top cover on page 33](#)).

Remove the display assembly:

1. Disconnect the display panel cable **(1)** from the system board.
2. Release the display panel cable from the clips **(2)** and routing channel built into the base enclosure.
3. Disconnect the wireless antenna cables **(3)** from the WLAN module.

4. Release the wireless antenna cables from the clips **(4)** and routing channel built into the base enclosure.

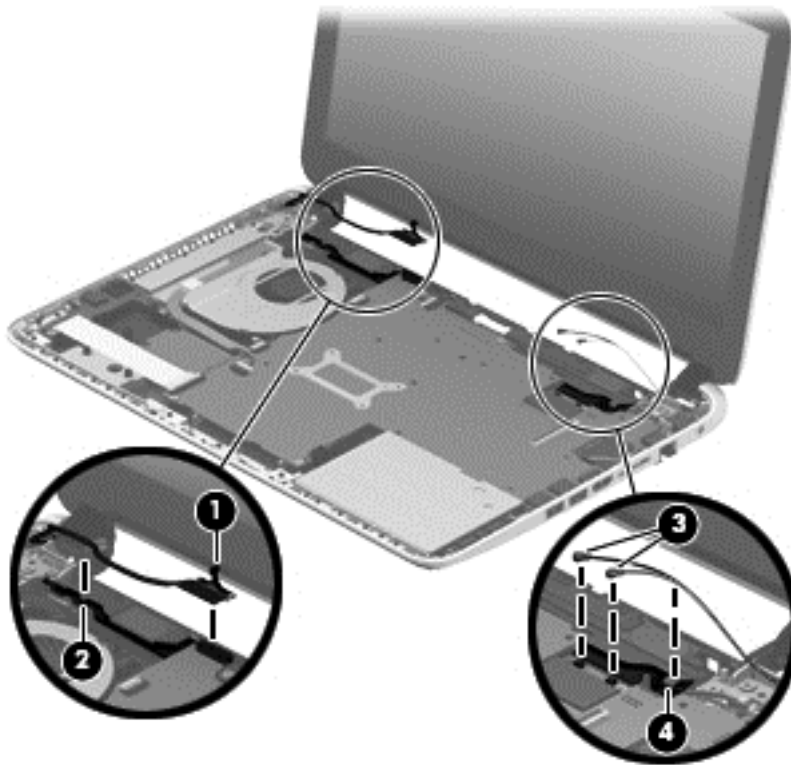

5. Remove the four Phillips PM2.5x5.6 screws **(1)** that secure the display assembly to the base enclosure.

6. Remove the display assembly **(2)**.

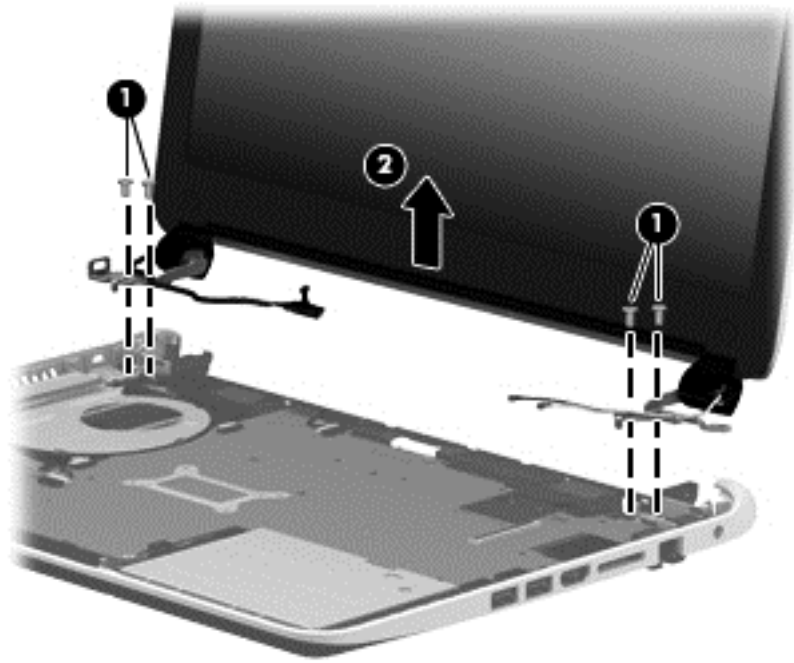

Reverse this procedure to install the display assembly.

System board



NOTE: The system board spare part kit includes the processor and replacement thermal material.

Description	Spare part number
Equipped with an AMD A8-5545M processor (2.70-/1.70-GHz, 4.00-MB L2 cache, 1333-MHz DDR3L, quad core, 19 W) and the Windows 8 Standard operating system	727202-501
Equipped with an AMD A8-5545M processor (2.70-/1.70-GHz, 4.00-MB L2 cache, 1333-MHz DDR3L, quad core, 19 W) and the Linux operating system	727202-001
Equipped with an AMD A6-5200 processor (2.00-GHz, 2.00-MB L2 cache, 1600-MHz DDR3L, quad core, 25 W) and the Windows 8 Standard operating system	727200-501
Equipped with an AMD A6-5200 processor (2.00-GHz, 2.00-MB L2 cache, 1600-MHz DDR3L, quad core, 25 W) and the Linux operating system	727200-001
Equipped with an AMD A4-5000 processor (1.50-GHz, 2.00-MB L2 cache, 1600-MHz DDR3L, quad core, 15 W) and the Windows 8 Standard operating system	727199-501
Equipped with an AMD A4-5000 processor (1.50-GHz, 2.00-MB L2 cache, 1600-MHz DDR3L, quad core, 15 W) and the Linux operating system	727199-001

Before removing the system board, follow these steps:

1. Turn off the computer. If you are unsure whether the computer is off or in Hibernation, turn the computer on, and then shut it down through the operating system.
2. Disconnect the power from the computer by unplugging the power cord from the computer.
3. Disconnect all external devices from the computer.
4. Remove the battery (see [Battery on page 30](#)), and then remove the following cables:
 - a. Keyboard (see [Keyboard on page 31](#)).
 - b. Top cover (see [Top cover on page 33](#)).
 - c. Fan (see [Fan on page 42](#)).
 - d. WLAN module (see [WLAN module on page 44](#)).

When replacing the system board, be sure that the following components are removed from the defective system board and installed on the replacement system board:

- Memory module (see [Memory module on page 52](#))
- Hard drive connector cable (see [Hard drive connector cable on page 53](#))
- RTC battery (see [RTC battery on page 55](#))
- Heat sink (see [Heat sink on page 56](#))
- Power connector cable (see [Power connector cable on page 58](#))

Remove the system board:

1. Disconnect the following cables from the system board.
 - (1) USB board cable
 - (2) Display panel cable
 - (3) Speaker cable
2. Release the power connector (4) from the clip molded into the base enclosure.

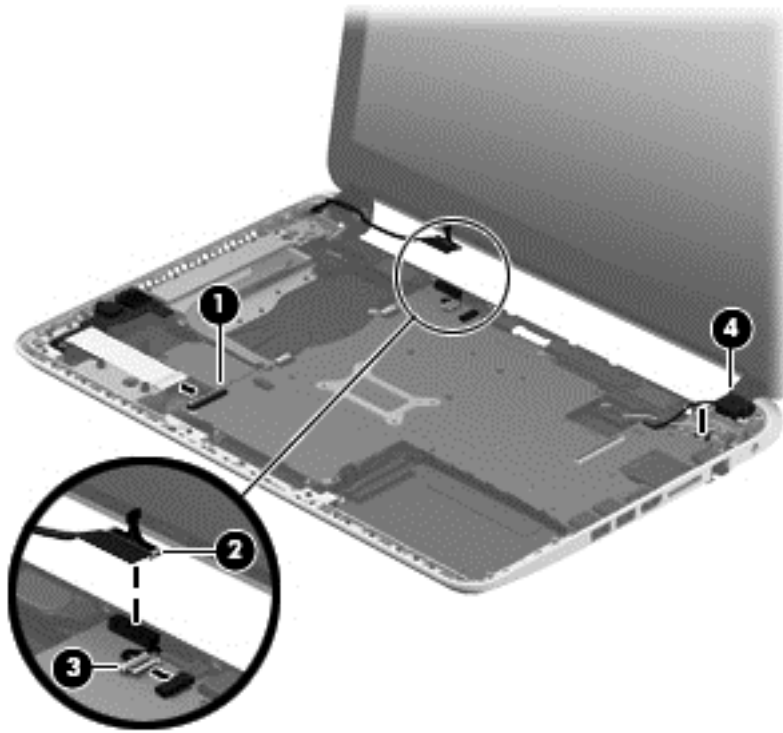

3. Remove the four Phillips PM2.5×5.6 screws that secure the system board to the base enclosure.

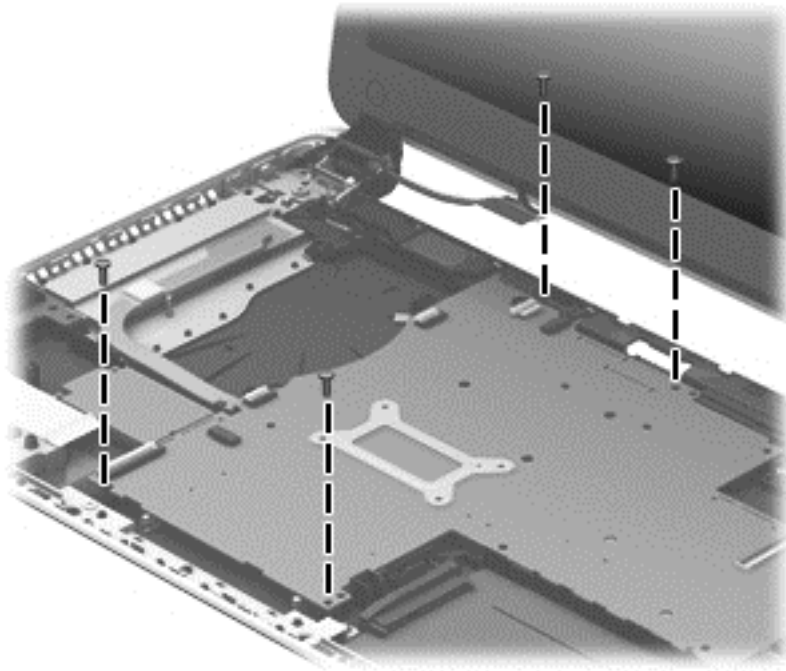

4. Lift the left side of the system board **(1)** until it rests at an angle.
5. Remove the system board **(2)** by sliding it up and to the left at an angle.

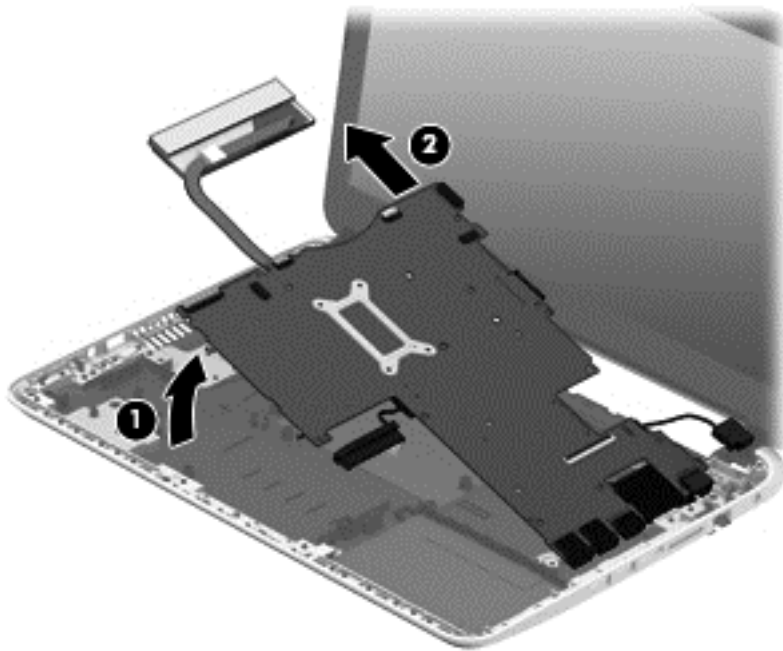

Reverse this procedure to install the system board.

Memory module

Description	Spare part number
4-GB (PC3L, 12800, 1600-MHz)	691740-001
2-GB (PC3L, 12800, 1600-MHz)	691739-001

Update BIOS before adding memory modules

Before adding new memory, make sure you update the computer to the latest BIOS.

CAUTION: Failure to update the computer to the latest BIOS prior to installing new memory may result in various system problems.

To update BIOS:

1. Navigate to www.hp.com.
2. Click **Support & Drivers > click Drivers & Software**.
3. In the **Enter a product name/number box**, type the computer model information, and then click **Search**.
4. Click the link for the computer model.
5. Select the operating system, and then click **Next**.
6. Under **Step 2: Select a Download**, click the **BIOS** link.
7. Click the link for the most recent BIOS.
8. Click the **Download** button, and then follow the on-screen instructions.

Before removing a memory module, follow these steps:

1. Turn off the computer. If you are unsure whether the computer is off or in Hibernation, turn the computer on, and then shut it down through the operating system.
2. Disconnect the power from the computer by unplugging the power cord from the computer.
3. Disconnect all external devices from the computer.
4. Remove the battery (see [Battery on page 30](#)), and then remove the following cables:
 - a. Keyboard (see [Keyboard on page 31](#)).
 - b. Top cover (see [Top cover on page 33](#)).
 - c. Fan (see [Fan on page 42](#)).
 - d. WLAN module (see [WLAN module on page 44](#)).
 - e. System board (see [System board on page 49](#)).

Remove the memory module:

1. Turn the system board upside down with the front toward you.
2. Spread the retaining tabs **(1)** on each side of the memory module slot to release the memory module. (The memory module tilts up.)
3. Remove the memory module **(2)** by pulling the module away from the slot at an angle.

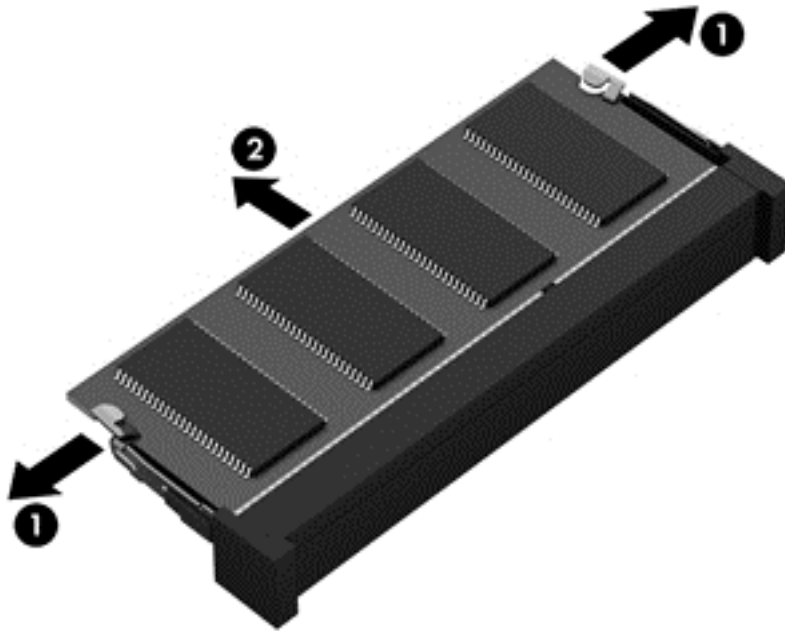

Reverse this procedure to install a memory module.

Hard drive connector cable

 **NOTE:** The hard drive connector cable is included in the Hard Drive Hardware Kit, spare part number 725626-001.

Before removing the system board, follow these steps:

1. Turn off the computer. If you are unsure whether the computer is off or in Hibernation, turn the computer on, and then shut it down through the operating system.
2. Disconnect the power from the computer by unplugging the power cord from the computer.
3. Disconnect all external devices from the computer.
4. Remove the battery (see [Battery on page 30](#)), and then remove the following cables:
 - a. Keyboard (see [Keyboard on page 31](#)).
 - b. Top cover (see [Top cover on page 33](#)).
 - c. Fan (see [Fan on page 42](#)).

- d. WLAN module (see [WLAN module on page 44](#)).
- e. System board (see [System board on page 49](#)).

Remove the hard drive connector cable:

1. Turn the system board upside down with the front toward you.
2. Disconnect the hard drive connector cable from the system board.

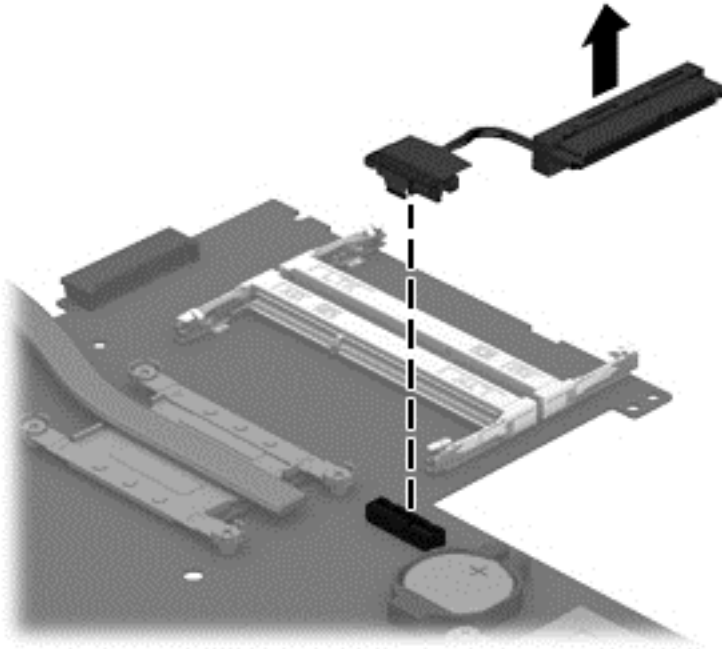

Reverse this procedure to install the hard drive connector cable.

RTC battery

Description	Spare part number
RTC battery	697917-001

Before removing the RTC battery, follow these steps:

1. Turn off the computer. If you are unsure whether the computer is off or in Hibernation, turn the computer on, and then shut it down through the operating system.
2. Disconnect the power from the computer by unplugging the power cord from the computer.
3. Disconnect all external devices from the computer.
4. Remove the battery (see [Battery on page 30](#)), and then remove the following cables:
 - a. Keyboard (see [Keyboard on page 31](#)).
 - b. Top cover (see [Top cover on page 33](#)).
 - c. Fan (see [Fan on page 42](#)).
 - d. WLAN module (see [WLAN module on page 44](#)).
 - e. System board (see [System board on page 49](#)).

Remove the RTC battery:

1. Turn the system board upside down with the front toward you.
2. Use a thin, non-conductive tool **(1)** to remove the RTC battery **(2)** from the socket on the system board.

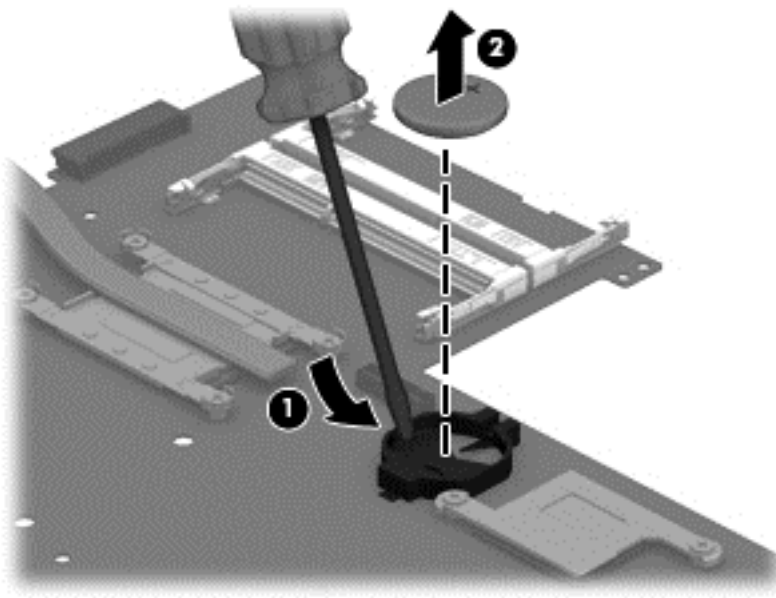

When installing the RTC battery, make sure the “+” sign faces up.

Heat sink



NOTE: The heat sink spare part kit includes replacement thermal material. Replacement thermal material is also available in the Thermal Material Kit, spare part number 725659-001.

Description	Spare part number
Heat sink for use only on computer models equipped with an AMD-A8, AMD-A4, AMD-E2 processor (includes replacement thermal material)	726214-001
Heat sink for use only on computer models equipped with an AMD-A6 processor (includes replacement thermal material)	727545-001

Before removing the heat sink, follow these steps:

1. Turn off the computer. If you are unsure whether the computer is off or in Hibernation, turn the computer on, and then shut it down through the operating system.
2. Disconnect the power from the computer by unplugging the power cord from the computer.
3. Disconnect all external devices from the computer.
4. Remove the battery (see [Battery on page 30](#)), and then remove the following cables:
 - a. Keyboard (see [Keyboard on page 31](#)).
 - b. Top cover (see [Top cover on page 33](#)).
 - c. Fan (see [Fan on page 42](#)).
 - d. WLAN module (see [WLAN module on page 44](#)).
 - e. System board (see [System board on page 49](#)).

Remove the heat sink:

1. Turn the system board upside down, with the front toward you.
2. Following the 1 through 4 sequence stamped into the heat sink, loosen the four captive Phillips screws **(1)** that secure the heat sink to the system board.

3. Remove the heat sink **(2)**.

 **NOTE:** Due to the adhesive quality of the thermal material located between the heat sink and the system board components, it may be necessary to move the heat sink from side to side to detach it.

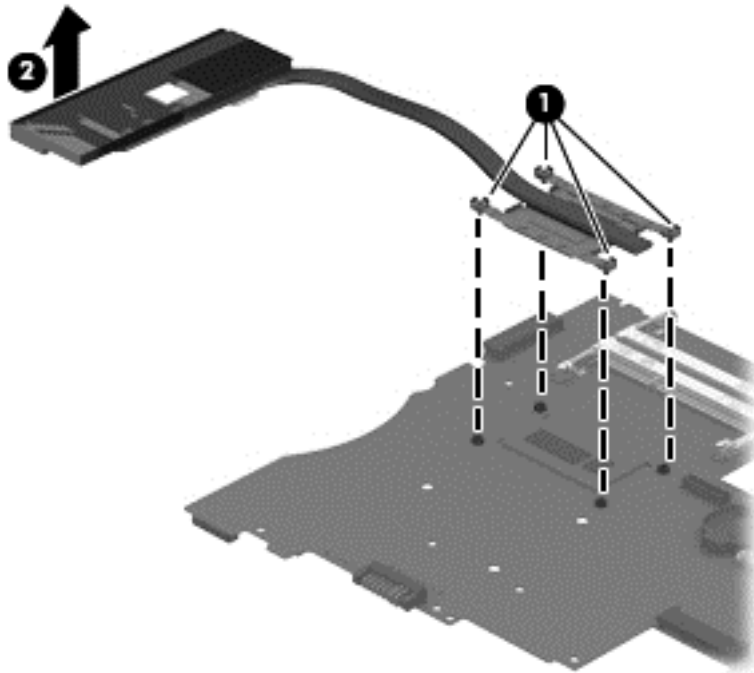

 **NOTE:** The thermal material must be thoroughly cleaned from the surfaces of the heat sink and the system board components each time the heat sink is removed. Replacement thermal material is included with the heat sink, processor, and system board spare part kits. Thermal paste is used on the processor **(1)** and the heat sink section **(2)** that services it.

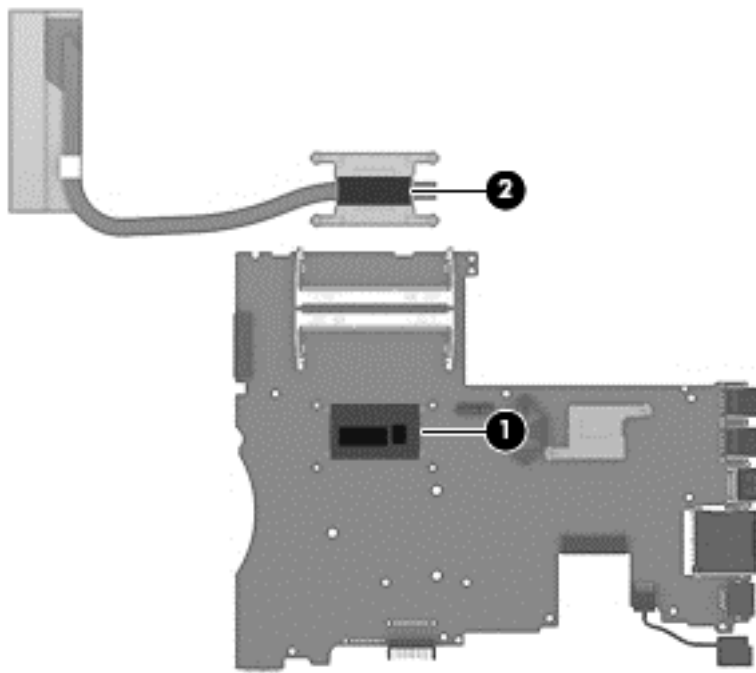

Reverse this procedure to install the heat sink.

Power connector cable

Description	Spare part number
Power connector cable	722907-001

Before removing the power connector cable, follow these steps:

1. Turn off the computer. If you are unsure whether the computer is off or in Hibernation, turn the computer on, and then shut it down through the operating system.
2. Disconnect the power from the computer by unplugging the power cord from the computer.
3. Disconnect all external devices from the computer.
4. Remove the battery (see [Battery on page 30](#)), and then remove the following cables:
 - a. Keyboard (see [Keyboard on page 31](#)).
 - b. Top cover (see [Top cover on page 33](#)).
 - c. Fan (see [Fan on page 42](#)).
 - d. WLAN module (see [WLAN module on page 44](#)).
 - e. System board (see [System board on page 49](#)).

Remove the power connector cable:

1. Turn the system board upside down, with the rear toward you.

2. Disconnect the power connector cable from the system board.

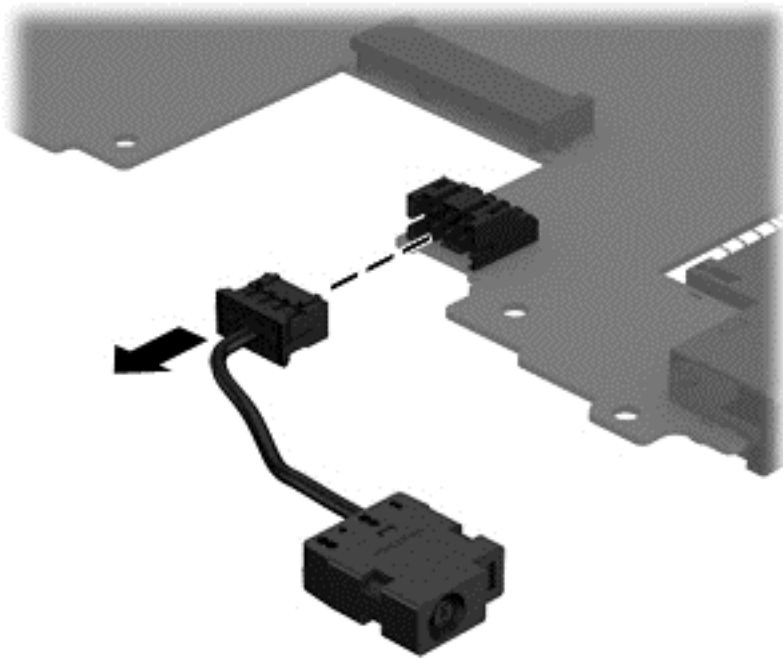

Reverse this procedure to install the power connector cable.

Speakers

Description	Spare part number
Speakers (include speaker cables)	726208-001

Before removing the speakers, follow these steps:

1. Turn off the computer. If you are unsure whether the computer is off or in Hibernation, turn the computer on, and then shut it down through the operating system.
2. Disconnect the power from the computer by unplugging the power cord from the computer.
3. Disconnect all external devices from the computer.
4. Remove the battery (see [Battery on page 30](#)), and then remove the following cables:
 - a. Keyboard (see [Keyboard on page 31](#)).
 - b. Top cover (see [Top cover on page 33](#)).
 - c. Fan (see [Fan on page 42](#)).
 - d. WLAN module (see [WLAN module on page 44](#)).
 - e. System board (see [System board on page 49](#)).

Remove the speakers:

1. Release the speaker cable from the retention clip **(1)** built into the base enclosure.
2. Release the speakers from the alignment posts **(2)** built into the base enclosure.

3. Remove the speakers (3).

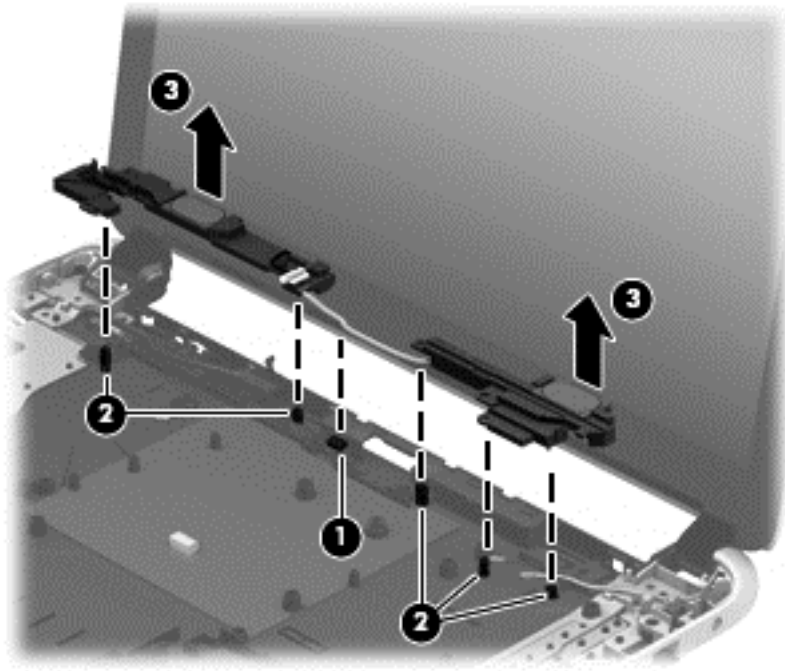

Reverse this procedure to install the speakers.

7 Using Setup Utility (BIOS) and System Diagnostics

Setup Utility, or Basic Input/Output System (BIOS), controls communication between all the input and output devices on the system (such as disk drives, display, keyboard, mouse, and printer). Setup Utility (BIOS) includes settings for the types of devices installed, the startup sequence of the computer, and the amount of system and extended memory.

Starting Setup Utility (BIOS)

To start Setup Utility (BIOS), turn on or restart the computer, quickly press `esc`, and then press `f10`.

Information about how to navigate in Setup Utility (BIOS) is located at the bottom of the screen.

 **NOTE:** Use extreme care when making changes in Setup Utility (BIOS). Errors can prevent the computer from operating properly.

Updating the BIOS

Updated versions of the BIOS may be available on the HP website.

Most BIOS updates on the HP website are packaged in compressed files called SoftPaqs.

Some download packages contain a file named `Readme.txt`, which contains information regarding installing and troubleshooting the file.

Determining the BIOS version

To determine whether available BIOS updates contain later BIOS versions than those currently installed on the computer, you need to know the version of the system BIOS currently installed.

BIOS version information (also known as *ROM date* and *System BIOS*) can be displayed by pressing `fn + esc` (if you are already in Windows) or by using Setup Utility (BIOS).

1. Start Setup Utility (BIOS).
2. Use the arrow keys to select **Main**.
3. To exit Setup Utility (BIOS) without saving your changes, use the arrow keys to select **Exit**, select **Exit Discarding Changes**, and then press `enter`.

Downloading a BIOS update

 **CAUTION:** CAUTION: To reduce the risk of damage to the computer or an unsuccessful installation, download and install a BIOS update only when the computer is connected to reliable external power using the AC adapter. Do not download or install a BIOS update while the computer is running on battery power, docked in an optional docking device, or connected to an optional power source. During the download and installation, follow these instructions:

Do not disconnect power from the computer by unplugging the power cord from the AC outlet.

Do not shut down the computer or initiate Sleep.

Do not insert, remove, connect, or disconnect any device, cable, or cord.

1. From the Start screen, select the **HP Support Assistant** app.
2. Select **Updates and tune-ups**, and then select **Check for HP updates now**.
3. Follow the on-screen instructions.
4. At the download area, follow these steps:
 - a. Identify the most recent BIOS update and compare it to the BIOS version currently installed on your computer. Make a note of the date, name, or other identifier. You may need this information to locate the update later, after it has been downloaded to your hard drive.
 - b. Follow the on-screen instructions to download your selection to the hard drive.

Make a note of the path to the location on your hard drive where the BIOS update is downloaded. You will need to access this path when you are ready to install the update.

 **NOTE:** If you connect your computer to a network, consult the network administrator before installing any software updates, especially system BIOS updates.

BIOS installation procedures vary. Follow any instructions that are displayed on the screen after the download is complete. If no instructions are displayed, follow these steps:

1. From the Start screen, type *e*, and then select **File Explorer**.
2. Click your hard drive designation. The hard drive designation is typically Local Disk (C:).
3. Using the hard drive path you recorded earlier, open the folder on your hard drive that contains the update.
4. Double-click the file that has an .exe extension (for example, *filename.exe*).

The BIOS installation begins.

5. Complete the installation by following the on-screen instructions.

 **NOTE:** After a message on the screen reports a successful installation, you can delete the downloaded file from your hard drive.

Using System Diagnostics

System Diagnostics allows you to run diagnostic tests to determine if the computer hardware is functioning properly.

To start System Diagnostics:

1. Turn on or restart the computer, quickly press `esc`, and then press `f2`.
2. Click the diagnostic test you want to run, and then follow the on-screen instructions.



NOTE: If you need to stop a diagnostic test while it is running, press `esc`.

8 Specifications

Computer specifications

	Metric	U.S.
Dimensions		
Width	37.60 cm	14.80 in
Depth	24.70 cm	9.72 in
Height (front to rear)	3.05 to 3.58 cm	1.20 to 1.41 in
Weight	2.45 kg	5.39 lb
Input power		
Operating voltage and current	18.5V/ 3.5A or 19.5V/ 3.33A – 65W 19V/ 4.74A or 19.5V/ 4.62A – 90W	
Temperature		
Operating	5°C to 35°C	41°F to 95°F
Nonoperating	-20°C to 60°C	-4°F to 140°F
Relative humidity (noncondensing)		
Operating	10% to 90%	
Nonoperating	5% to 95%	
Maximum altitude (unpressurized)		
Operating	-15 m to 3,048 m	-50 ft to 10,000 ft
Nonoperating	-15 m to 12,192 m	-50 ft to 40,000 ft
NOTE: Applicable product safety standards specify thermal limits for plastic surfaces. The device operates well within this range of temperatures.		

14.0-in, SVA, display panel display specifications

	Metric	U.S.
Dimensions		
Height	19.6 cm	7.72 in
Width	34.7 cm	13.66 in
Diagonal	39.8 cm	15.67 in
Number of colors	Up to 16.8 million	
Contrast ratio	200:1 (typical)	
Brightness	250 nits (typical)	
Pixel resolution		
Pitch	0.197 × 0.197 mm	
Format	1366 × 768	
Configuration	RGB vertical stripe	
Backlight	LED	
Character display	80 × 25	
Total power consumption	3.46 W	
Viewing angle	±65° horizontal, +50° vertical (typical)	

Hard drive specifications

	640-GB*	500-GB*	320-GB*
Dimensions			
Height	9.5 mm	9.5 mm	9.5 mm
Length	100.4 mm	100.4 mm	100.4 mm
Width	69.9 mm	69.9 mm	69.9 mm
Weight	110 g	110 g	110 g
Interface type	SATA	SATA	SATA
Transfer rate			
Synchronous (maximum)	1.1 GB/sec	1.1 GB/sec	1.1 GB/sec
Security	ATA security	ATA security	ATA security
Seek times (typical read, including setting)			
Single track	1.5 ms	1.5 ms	1.5 ms
Average (read/write)	11/13 ms	11/13 ms	11/13 ms
Maximum	22 ms	22 ms	22 ms
Logical blocks	1,250,269,655	976,773,168	628,142,448
Disk rotational speed	5400 rpm	5400 rpm	5400 rpm
Operating temperature	0°C to 60°C (32°F to 140°F)		
*1 GB = 1 billion bytes when referring to hard drive storage capacity. Actual accessible capacity is less.			
NOTE: Certain restrictions and exclusions apply. Contact technical support for details.			

9 Backing up, restoring, and recovering

Your computer includes tools provided by HP and the operating system to help you safeguard your information and retrieve it if you ever need to. These tools will help you return your computer to a proper working state or even back to the original factory state, all with simple steps.

This chapter provides information about the following processes:

- Creating recovery media and backups
- Restoring and recovering your system



NOTE: This guide describes an overview of backing up, restoring and recovering options. For more details about the tools provided, see Help and Support. From the Start screen, type **h**, and then select **Help and Support**.

Creating recovery media and backups

Recovery after a system failure is only as good as your most recent backup.

1. After you successfully set up the computer, create HP Recovery media. This step creates a backup of the HP Recovery partition on the computer. The backup can be used to reinstall the original operating system in cases where the hard drive is corrupted or has been replaced.

HP Recovery media you create will provide the following recovery options:

- System Recovery—Reinstalls the original operating system and the programs that were installed at the factory.
- Minimized Image Recovery—Reinstalls the operating system and all hardware-related drivers and software, but not other software applications.
- Factory Reset—Restores the computer to the state its original factory state by deleting all information from the hard drive and re-creating the partitions. Then it reinstalls the operating system and the software that was installed at the factory.

See [Creating HP Recovery media on page 69](#).

2. As you add hardware and software programs, create system restore points. A system restore point is a snapshot of certain hard drive contents saved by Windows System Restore at a specific time. A system restore point contains information that Windows uses, such as registry settings. Windows creates a system restore point for you automatically during a Windows update and during other system maintenance (such as a software update, security scanning, or system diagnostics). You can also manually create a system restore point at any time. For more information and steps for creating specific system restore points, see Windows Help and Support. From the Start screen, type **h**, and then select **Help and Support**.
3. As you add photos, video, music, and other personal files, create a backup of your personal information. Windows File History can be set to regularly and automatically back up files from libraries, Desktop, contacts, and favorites. If files are accidentally deleted from the hard drive and they can no longer be restored from the Recycle Bin, or if files become corrupted, you can restore the files that you backed up using File History. Restoring files is also useful if you ever choose to reset the computer by reinstalling Windows or choose to recover using HP Recovery Manager.



NOTE: File History is not enabled by default, so you must turn it on.

For more information and steps for enabling Windows File History, see Windows Help and Support. From the Start screen, type **h**, and then select **Help and Support**.

Creating HP Recovery media

HP Recovery Manager is a software program that offers a way to create recovery media after you successfully set up the computer. HP Recovery media can be used to perform system recovery if the hard drive becomes corrupted. System recovery reinstalls the original operating system and the software programs installed at the factory, and then configures the settings for the programs. HP Recovery media can also be used to customize the system or aid in the replacement of a hard drive.

- Only one set of HP Recovery media can be created. Handle these recovery tools carefully, and keep them in a safe place.
- HP Recovery Manager examines the computer and determines the required storage capacity for the blank USB flash drive or the number of blank DVD discs that will be required.
- To create recovery discs, your computer must have an optical drive with DVD writer capability, and you must use only high-quality blank DVD-R, DVD+R, DVD-R DL, DVD+R DL discs. Do not use rewritable discs such as CD±RW, DVD±RW, double-layer DVD±RW, or BD-RE (rewritable Blu-ray) discs; they are not compatible with HP Recovery Manager software. Or instead you can use a high-quality blank USB flash drive.
- If your computer does not include an integrated optical drive with DVD writer capability, but you would like to create DVD recovery media, you can use an external optical drive (purchased separately) to create recovery discs, or you can obtain recovery discs for your computer from the HP website. For U.S. support, go to <http://www.hp.com/go/contactHP>. For worldwide support, go to http://welcome.hp.com/country/us/en/wwcontact_us.html. If you use an external optical drive, it must be connected directly to a USB port on the computer; the drive cannot be connected to a USB port on an external device, such as a USB hub.

- Be sure that the computer is connected to AC power before you begin creating the recovery media.
- The creation process can take up to an hour or more. Do not interrupt the creation process.
- If necessary, you can exit the program before you have finished creating all of the recovery DVDs. HP Recovery Manager will finish burning the current DVD. The next time you start HP Recovery Manager, you will be prompted to continue, and the remaining discs will be burned.

To create HP Recovery media:

1. From the Start screen, type `recovery`, and then select **HP Recovery Manager**.
2. Select **Recovery Media Creation**, and follow the on-screen instructions to continue.

If you ever need to recover the system, see [Recovering using HP Recovery Manager on page 72](#).

Restore and recovery

There are several options for recovering your system. Choose the method that best matches your situation and level of expertise:

- If you need to restore your personal files and data, you can use Windows File History to restore your information from the backups you created. For more information and steps for using File History, see Windows Help and Support. From the Start screen, type `h`, and then select **Help and Support**.
- If you need to correct a problem with a preinstalled application or driver, use the Drivers and Applications Reinstall option of HP Recovery Manager to reinstall the individual application or driver.

From the Start screen, type `recovery`, select **HP Recovery Manager**, and then select **Drivers and Applications Reinstall**, and follow the on-screen instructions.

- If you want to restore the system to a previous state without losing any personal information, Windows System Restore is an option. System Restore allows you to restore without the requirements of Windows Refresh or a reinstallation. Windows creates system restore points automatically during a Windows update and other system maintenance events. Even if you did not manually create a restore point, you can choose to restore to a previous point, automatically created. For more information and steps for using Windows System Restore, see Windows Help and Support. From the Start screen, type `h`, and then select **Help and Support**.
- If you want a quick and easy way to recover the system without losing your personal information, settings, or apps that came preinstalled on your computer or were purchased from the Windows Store, consider using Windows Refresh. This option does not require backing up data to another drive. See [Using Windows Refresh for quick and easy recovery on page 71](#).
- If you want to reset your computer to its original state, Windows provides an easy way to remove all personal data, apps, and settings, and reinstall Windows.

For more information, see [Remove everything and reinstall Windows on page 72](#).

- If you want to reset your computer using a minimized image, you can choose the HP Minimized Image Recovery option from the HP Recovery partition (select models only) or HP Recovery media. Minimized Image Recovery installs only drivers and hardware-enabling applications. Other applications included in the image continue to be available for installation through the Drivers and Applications Reinstall option in HP Recovery Manager.

For more information, see [Recovering using HP Recovery Manager on page 72](#).

- If you want to recover the computer's original factory partitioning and content, you can choose the System Recovery option from the HP Recovery media. For more information, see [Recovering using HP Recovery Manager on page 72](#).
- If you have replaced the hard drive, you can use the Factory Reset option of HP Recovery media to restore the factory image to the replacement drive. For more information, see [Recovering using HP Recovery Manager on page 72](#).
- If you wish to remove the recovery partition to reclaim hard drive space, HP Recovery Manager offers the Remove Recovery Partition option.

For more information, see [Removing the HP Recovery partition on page 74](#).

Using Windows Refresh for quick and easy recovery

When your computer is not working properly and you need to regain system stability, the Windows Refresh option allows you to start fresh and keep what is important to you.

 **IMPORTANT:** Refresh removes any traditional applications that were not originally installed on the system at the factory.

 **NOTE:** During Refresh, a list of removed traditional applications will be saved so that you have a quick way to see what you might need to reinstall. See Help and Support for instructions on reinstalling traditional applications. From the Start screen, type **h**, and then select **Help and Support**.

 **NOTE:** You may be prompted for your permission or password when using Refresh. See Windows Help and Support for more information. From the Start screen, type **h**, and then select **Help and Support**.

To start Refresh:

1. On the Start screen, point to the far-right upper or lower corner of the screen to display the charms.
2. Click **Settings**.
3. Click **Change PC settings** in the bottom-right corner of the screen, and then select **General** from the PC settings screen.
4. Under **Refresh your PC without affecting your files**, select **Get started**, and follow the on-screen instructions.

Remove everything and reinstall Windows

Sometimes you want to perform detailed reformatting of your computer, or you want to remove personal information before you give away or recycle your computer. The process described in this section provides a speedy, simple way to return the computer to its original state. This option removes all personal data, apps, and settings from your computer, and reinstalls Windows.

 **IMPORTANT:** This option does not provide backups of your information. Before using this option, back up any personal information you wish to retain.

You can initiate this option by using the **F11** key or from the Start screen.

To use the **F11** key:

1. Press **F11** while the computer boots.
– or –
Press and hold **F11** as you press the power button.
2. Select **Troubleshoot** from the boot options menu.
3. Select **Reset your PC**, and follow the on-screen instructions.

To use the Start screen:

1. On the Start screen, point to the far-right upper or lower corner of the screen to display the charms.
2. Click **Settings**.
3. Click **Change PC settings** in the bottom-right corner of the screen, and then select **General** from the PC settings screen.
4. Under **Remove everything and reinstall Windows**, select **Get started**, and follow the on-screen instructions.

Recovering using HP Recovery Manager

HP Recovery Manager software allows you to recover the computer to its original factory state. Using the HP Recovery media you created, you can choose from one of the following recovery options:

- **System Recovery**—Reinstalls the original operating system, and then configures the settings for the programs that were installed at the factory.
- **Minimized Image Recovery**—Reinstalls the operating system and all hardware-related drivers and software, but not other software applications.
- **Factory Reset**—Restores the computer to the state its original factory state by deleting all information from the hard drive and re-creating the partitions. Then it reinstalls the operating system and the software that was installed at the factory.

The HP Recovery partition (select models only) allows Minimized Image Recovery.

What you need to know

- HP Recovery Manager recovers only software that was installed at the factory. For software not provided with this computer, you must either download the software from the manufacturer's website or reinstall the software from the media provided by the manufacturer.
- Recovery through HP Recovery Manager should be used as a final attempt to correct computer issues.
- HP Recovery media must be used if the computer hard drive fails.
- To use the Factory Reset or System Recovery options, you must use HP Recovery media.
- If the HP Recovery media do not work, you can obtain recovery media for your system from the HP website. For U.S. support, go to <http://www.hp.com/go/contactHP>. For worldwide support, go to http://welcome.hp.com/country/us/en/wwcontact_us.html.



IMPORTANT: HP Recovery Manager does not automatically provide backups of your personal data. Before beginning recovery, back up any personal data you wish to retain.

Using the HP Recovery partition to recover a minimized image (select models only)

The HP Recovery partition (select models only) allows you to perform a minimized image recovery without the need for recovery discs or a recovery USB flash drive. This type of recovery can only be used if the hard drive is still working.

To start HP Recovery Manager from the HP Recovery partition:

1. Press **f11** while the computer boots.
– or –
Press and hold **f11** as you press the power button.
2. Select **Troubleshoot** from the boot options menu.
3. Select **HP Recovery Manager**, and follow the on-screen instructions.

Using HP Recovery media to recover

You can use HP Recovery media to recover the original system. This method can be used if your system does not have an HP Recovery partition or if the hard drive is not working properly.

1. If possible, back up all personal files.
2. Insert the first HP Recovery disc you created into the optical drive on your computer or into an optional external optical drive, and then restart the computer.

– or –

Insert the HP Recovery USB flash drive you created into a USB port on your computer, and then restart the computer.

 **NOTE:** If the computer does not automatically restart in HP Recovery Manager, change the computer boot order. See [Changing the computer boot order on page 74](#).

3. Follow the on-screen instructions.

Changing the computer boot order

If computer does not restart in HP Recovery Manager, you can change the computer boot order, which is the order of devices listed in BIOS where the computer looks for startup information. You can change the selection for an optical drive or a USB flash drive.

To change the boot order:

1. Insert the HP Recovery media you created.
2. Restart the computer.
3. Press and hold **esc** while the computer is restarting, and then press **f9** for boot options.
4. Select the optical drive or USB flash drive you want to boot from.
5. Follow the on-screen instructions.

Removing the HP Recovery partition

HP Recovery Manager software allows you to remove the HP Recovery partition to free up hard drive space.

 **IMPORTANT:** Removing the HP Recovery partition means you can no longer use Windows Refresh, the Windows Remove everything and reinstall Windows option, or the HP Recovery Manager option for minimized image recovery. Create HP Recovery media before removing the Recovery partition to ensure you have recovery options; see [Creating HP Recovery media on page 69](#).

Follow these steps to remove the HP Recovery partition:

1. From the Start screen, type `recovery`, and then select **HP Recovery Manager**.
2. Select **Remove Recovery Partition**, and follow the on-screen instructions to continue.

10 Power cord set requirements

The wide-range input feature of the computer permits it to operate from any line voltage from 100 to 120 volts AC, or from 220 to 240 volts AC.

The 3-conductor power cord set included with the computer meets the requirements for use in the country or region where the equipment is purchased.

Power cord sets for use in other countries and regions must meet the requirements of the country or region where the computer is used.

Requirements for all countries

The following requirements are applicable to all countries and regions:

- The length of the power cord set must be at least **1.0 m** (3.3 ft) and no more than **2.0 m** (6.5 ft).
- All power cord sets must be approved by an acceptable accredited agency responsible for evaluation in the country or region where the power cord set will be used.
- The power cord sets must have a minimum current capacity of 10 amps and a nominal voltage rating of 125 or 250 V AC, as required by the power system of each country or region.
- The appliance coupler must meet the mechanical configuration of an EN 60 320/IEC 320 Standard Sheet C13 connector for mating with the appliance inlet on the back of the computer.

Requirements for specific countries and regions

Country/region	Accredited agency	Applicable note number
Australia	EANSW	1
Austria	OVE	1
Belgium	CEBC	1
Canada	CSA	2
Denmark	DEMKO	1
Finland	FIMKO	1
France	UTE	1
Germany	VDE	1
Italy	IMQ	1
Japan	METI	3
The Netherlands	KEMA	1
Norway	NEMKO	1
The People's Republic of China	COC	5
South Korea	EK	4
Sweden	SEMKO	1
Switzerland	SEV	1
Taiwan	BSMI	4
The United Kingdom	BSI	1
The United States	UL	2

1. The flexible cord must be Type HO5VV-F, 3-conductor, 1.0-mm² conductor size. Power cord set fittings (appliance coupler and wall plug) must bear the certification mark of the agency responsible for evaluation in the country or region where it will be used.
2. The flexible cord must be Type SPT-3 or equivalent, No. 18 AWG, 3-conductor. The wall plug must be a two-pole grounding type with a NEMA 5-15P (15 A, 125 V) or NEMA 6-15P (15 A, 250 V) configuration.
3. The appliance coupler, flexible cord, and wall plug must bear a "T" mark and registration number in accordance with the Japanese Dentori Law. The flexible cord must be Type VCT or VCTF, 3-conductor, 1.00-mm² conductor size. The wall plug must be a two-pole grounding type with a Japanese Industrial Standard C8303 (7 A, 125 V) configuration.
4. The flexible cord must be Type RVV, 3-conductor, 0.75-mm² conductor size. Power cord set fittings (appliance coupler and wall plug) must bear the certification mark of the agency responsible for evaluation in the country or region where it will be used.
5. The flexible cord must be Type VCTF, 3-conductor, 0.75-mm² conductor size. Power cord set fittings (appliance coupler and wall plug) must bear the certification mark of the agency responsible for evaluation in the country or region where it will be used.

11 Recycling

When a non-rechargeable or rechargeable battery has reached the end of its useful life, do not dispose of the battery in general household waste. Follow the local laws and regulations in your area for battery disposal.

HP encourages customers to recycle used electronic hardware, HP original print cartridges, and rechargeable batteries. For more information about recycling programs, see the HP Web site at <http://www.hp.com/recycle>.

Index

- A**
 - AC adapter
 - spare part number 22
 - AC adapter light 13
 - AC adapter, spare part number 21
 - Action keys 8
 - adapter
 - spare part number 22
 - antenna
 - locations 6
 - audio, product description 2
 - audio-out jack 11
- B**
 - base enclosure, spare part number 19
 - base enclosure, spare part numbers 22
 - battery
 - removal 30
 - spare part number 19, 22
 - spare part numbers 30
 - battery bay 14
 - battery lock/unlock latch 14
 - battery release latch 14
 - bottom components 14
 - button component 7
 - buttons
 - power 7
 - TouchPad 10
- C**
 - cables, service considerations 25
 - caps lock light 9
 - chipset, product description 1
 - components
 - bottom 14
 - button 7
 - computer feet
 - spare part number 19, 22
 - computer major components 17
 - computer specifications 65
 - connectors, service considerations 25
 - display 5
 - keys 8
 - left-side 11
 - lights 9
 - right-side 13
 - TouchPad 10
- D**
 - display
 - components 5
 - specifications 66
 - display assembly
 - removal 46
 - spare part numbers 22, 23, 46
 - display panel
 - product description 1
 - drives, preventing damage 25
 - dummy weight
 - spare part number 22
 - DVD±RW Double-Layer with SuperMulti Drive
 - precautions 25
 - spare part number 20, 21
- E**
 - electrostatic discharge 26
 - equipment guidelines 28
 - esc key 8
 - Ethernet, product description 2
- F**
 - fan
 - removal 42
 - spare part number 22, 42
 - fan assembly
 - spare part number 19
 - feet
 - spare part number 19, 22
 - fn key 8
- G**
 - graphics, product description 1
 - grounding guidelines 26
 - guidelines
 - equipment 28
 - grounding 26
 - packaging 27
 - transporting 27
 - workstation 27
- H**
 - hard drive
 - precautions 25
 - product description 2
 - removal 38
 - spare part numbers 19, 20, 21, 38
 - specifications 67
 - hard drive bracket
 - illustrated 20
 - removal 39
 - hard drive connector cable
 - illustrated 20
 - removal 39, 53
 - spare part number 19
 - Hard Drive Hardware Kit
 - contents 20
 - spare part number 19, 20, 22
 - hard drive light 12

- HDMI port
 - HDMI 13
- headphone jack 11
- Heat sink
 - spare part number 19
- heat sink
 - removal 56
 - spare part number 22, 23, 56
- heat sink assembly
 - spare part number 19
- I**
- internal display switch
 - locations 6
- J**
- jacks
 - audio-out 11
 - headphone 11
- K**
- key components 8
- keyboard
 - product description 3
 - removal 31
 - spare part number 18, 22
 - spare part numbers 18, 31
- keys
 - Action 8
 - esc 8
 - fn 8
 - Windows logo 8
- L**
- left-side components 11
- light components 9
- lights
 - AC adapter 13
 - caps lock 9
 - hard drive 12
 - power 9, 12
 - webcam 6
 - wireless 9
- M**
- mass storage device
 - illustrated 20
 - precautions 25
- Memory card reader 13
- memory module
 - product description 2
- removal 52
- spare part numbers 19, 22, 52
- microphone
 - location 6
 - product description 2
- model name 1
- mute light
 - mute 9
- O**
- operating system, product
 - description 4
- optical drive
 - 21
 - precautions 25
 - product description 2
 - spare part number 20, 21
- P**
- packaging guidelines 27
- plastic parts, service
 - considerations 24
- pointing device, product
 - description 3
- port
 - USB 11
- ports
 - product description 3
 - USB 13
- power button 7
- power button board
 - removal 36
 - spare part number 18, 22, 36
- power connector 13
- power connector cable
 - removal 58
 - spare part number 19, 22, 58
- power cord
 - set requirements 75
 - spare part numbers 21
- power light 9, 12
- power requirements, product
 - description 3
- processor
 - product description 1
- product description
 - audio 2
 - chipset 1
 - display panel 1
- Ethernet 2
- graphics 1
- hard drive 2
- keyboard 3
- memory card reader 3
- memory module 2
- microphone 2
- operating system 4
- optical drive 2
- pointing device 3
- ports 3
- power requirements 3
- processors 1
- product name 1
- security 3
- serviceability 4
- video 2
- wireless 3
- product name 1
- R**
- removal/replacement
 - procedures 29, 33
- right-side components 13
- RJ-45
 - jack 13
- RTC Battery
 - spare part number 22
- RTC battery
 - removal 55
 - spare part number 19, 55
- Rubber Kit, spare part number 19, 22
- S**
- Screw Kit, spare part number 21, 22
- security cable slot 11
- security, product description 3
- service considerations
 - cables 25
 - connectors 25
 - plastic parts 24
- service tag 16
- serviceability, product description 4
- speakers
 - removal 60
 - spare part number 19, 22, 60

- specifications
 - computer 65
 - display 66
 - hard drive 67
- system board
 - removal 49
 - spare part number 23
 - spare part numbers 18, 19, 23, 49

T

- thermal pad
 - spare part number 22
- tools required 24
- top cover
 - removal 33
 - spare part number 22, 33
 - spare part numbers 18
- TouchPad button 10
- TouchPad button board
 - removal 37
 - spare part number 18, 22, 37
- TouchPad components 10
- TouchPad zone 10
- transporting guidelines 27

U

- USB 3.0 port 11
- USB board
 - removal 41
 - spare part number 19, 22, 41
- USB port 13

V

- vent 11
- vents 14
- video, product description 2

W

- webcam 6
- webcam light 6
- Windows logo key 8
- wireless antenna
 - locations 6
- wireless light 9
- wireless, product description 3
- WLAN module
 - removal 44
 - spare part numbers 18, 21, 22, 44
- workstation guidelines 27

