



HP EliteBook 8570w Mobile Workstation

Maintenance and Service Guide

© Copyright 2013 Hewlett-Packard
Development Company, L.P.

AMD is a trademark of Advanced Micro Devices, Inc. Bluetooth is a trademark owned by its proprietor and used by Hewlett-Packard Company under license. Intel, Core, and Centrino are trademarks of Intel Corporation in the U.S. and other countries. Microsoft and Windows are U.S. registered trademarks of Microsoft Corporation. SD Logo is a trademark of its proprietor.

The information contained herein is subject to change without notice. The only warranties for HP products and services are set forth in the express warranty statements accompanying such products and services. Nothing herein should be construed as constituting an additional warranty. HP shall not be liable for technical or editorial errors or omissions contained herein.

Third Edition: August 2013

Second Edition: October 2012

First Edition: July 2012

Document Part Number: 679384-003

Product notice

This guide describes features that are common to most models. Some features may not be available on your computer. Not all features are available in all editions of Windows 8.

This computer may require upgraded and/or separately purchased hardware, drivers, and/or software to take full advantage of Windows 8 functionality. See <http://www.microsoft.com> for details.

Software terms

By installing, copying, downloading, or otherwise using any software product preinstalled on this computer, you agree to be bound by the terms of the HP End User License Agreement (EULA). If you do not accept these license terms, your sole remedy is to return the entire unused product (hardware and software) within 14 days for a refund subject to the refund policy of your place of purchase.

For any further information or to request a full refund of the computer, please contact your local point of sale (the seller).

Safety warning notice

⚠ WARNING! To reduce the possibility of heat-related injuries or of overheating the computer, do not place the computer directly on your lap or obstruct the computer air vents. Use the computer only on a hard, flat surface. Do not allow another hard surface, such as an adjoining optional printer, or a soft surface, such as pillows or rugs or clothing, to block airflow. Also, do not allow the AC adapter to contact the skin or a soft surface, such as pillows or rugs or clothing, during operation. The computer and the AC adapter comply with the user-accessible surface temperature limits defined by the International Standard for Safety of Information Technology Equipment (IEC 60950).

Table of contents

1 Product description	1
2 External Component Identification	8
Top	8
TouchPad	8
Lights	10
Buttons and fingerprint reader (select models only)	11
Keys	13
Front	14
Right	16
Left	17
Rear	18
Display	19
Bottom	20
3 Illustrated parts catalog	22
Service tag	22
Computer major components	23
Display components	31
Plastics Kit	32
Cable Kit	33
Mass storage devices	34
Miscellaneous parts	35
Sequential part number listing	37
4 Removal and replacement procedures	48
Preliminary replacement requirements	48
Tools required	48
Service considerations	48
Plastic parts	48
Cables and connectors	49

Drive handling	49
Grounding guidelines	50
Electrostatic discharge damage	50
Packaging and transporting guidelines	51
Workstation guidelines	51
Equipment guidelines	52
Component replacement procedures	53
Service tag	53
Battery	54
Display panel (non-DreamColor)	55
SIM	59
Service door	60
Memory Modules (under service door)	62
RTC battery	64
WLAN module	65
WWAN module	68
Bluetooth module	70
Hard drive	72
Smart card reader	75
Upgrade bay device	77
Keyboard	81
Memory Modules (under keyboard)	85
Top cover	87
Power button board	90
Function button board	92
Fingerprint reader board	94
TouchPad button board	96
VGA port board	98
Fan and heat sink assembly	100
Graphics card	102
Processor	104
Audio/USB 3.0 board	106
Modem module	108
Speakers	110
ExpressCard/USB 2.0 assembly	113
Northbridge chip heat sink	115
System board	117
RJ-45 connector cable	120
Power connector cable	122
RJ-11 connector cable	124
Service door latch	126

Battery latch	128
Display assembly	130
5 Computer Setup	139
Windows 8	139
Using Computer Setup	139
Starting Computer Setup	139
Navigating and selecting in Computer Setup	139
Restoring factory settings in Computer Setup	140
Updating the BIOS	141
Determining the BIOS version	141
Downloading a BIOS update	142
Using Advanced System Diagnostics	143
Windows 7	144
Starting Computer Setup	144
Using Computer Setup	144
Navigating and selecting in Computer Setup	144
Restoring factory settings in Computer Setup	145
Updating the BIOS	146
Determining the BIOS version	146
Downloading a BIOS update	146
Using Advanced System Diagnostics	147
6 Specifications	148
Computer specifications	148
39.6-cm (15.6-in) HD+ display specifications	149
39.6-cm (15.6-in) FHD display specifications	150
Hard drive specifications	151
Solid state drive specifications	152
DVD±RW and CD-RW SuperMulti DL Combo Drive specifications	153
Blu-ray Disc ROM DVD±RW SuperMulti DL Combo Drive	154
DVD-ROM Drive specifications	155
7 Backup and recovery	156
Windows 8	156
Backing up your information	156
Performing a system recovery	157
Using the Windows recovery tools	157
Using f11 recovery tools	158
Using Windows 8 operating system media (purchased separately)	159

Using Windows Refresh for quick and easy recovery	159
Remove everything and reinstall Windows	160
Using HP Software Setup	161
Windows 7	161
Creating recovery media with HP Recovery Disc Creator	162
Creating recovery media	162
Backing up your information	162
Performing a system recovery	163
Using the Windows recovery tools	163
Using f11 recovery tools	164
Using a Windows 7 operating system DVD (purchased separately)	165
8 Power cord set requirements	166
Requirements for all countries and regions	166
Requirements for specific countries and regions	167
9 Recycling	168
Index	169

1 Product description

Category	Description
Product Name	HP EliteBook 8570w Mobile Workstation
Processors	Intel® Core™ processors
	Intel Quad Core i7-3840QM 2.80-GHz processor (SC turbo up to 3.80-GHz; 1600-MHz FSB, 8.0-MB L3 cache, 45 W)
	i7-3820QM, 2.70 GHz (Turbo up to 3.70 GHz), quad-core processor, 1600 MHz, 8 MB L3 Cache, 8 threads, 45W
	Intel Quad Core i7-3740QM 2.70-GHz processor (SC turbo up to 3.70-GHz; 1600-MHz FSB, 6.0-MB L3 cache, 45 W)
	i7-3720QM, 2.60GHz (Turbo up to 3.60 GHz), quad-core processor, 1600 MHz, 6 MB L3 Cache, 8 threads, 45W
	Intel Quad Core i7-3630QM 2.40-GHz processor (SC turbo up to 3.40-GHz; 1600-MHz FSB, 6.0-MB L3 cache, 45 W)
	i7-3610QM, 2.30 GHz (Turbo up to 3.30 GHz), quad-core processor 1600 MHz, 6MB L3 Cache, 8 threads, 45W
	i7-3520M, 2.90GHz (Turbo up to 3.60 GHz), dual-core processor, 1600 MHz, 4MB L3 Cache, 4 threads, 35W
	i5-3360M, 2.80 GHz (Turbo up to 3.50 GHz), dual-core processor, 1600 MHz, 3 MB L3 Cache, 4 threads, 35W
	i5-3320M, 2.60 GHz (Turbo up to 3.30 GHz), dual-core processor, 1600 MHz, 3 MB L3 Cache, 4 threads, 35W
Chipset	Mobile Intel QM77 chipset
Graphics	Models feature the following graphics subsystem boards, supporting: <ul style="list-style-type: none">• Open GL• Display Port 1.2• Up to four total displays (NVIDIA)• Up to five total displays (AMD)
	NVIDIA® Quadro® K2000M (NVIDIA N14P-Q3 2GB DDR3)
	NVIDIA Quadro K1000M (NVIDIA N14P-Q1 2GB DDR3)

Category	Description
Graphics <i>(continued)</i>	AMD FirePro™ M4000 (Chelsea XT GL 1GB GDDR5)
Display	<p>Display panel:</p> <ul style="list-style-type: none"> • Supports privacy filter • Wedge design <p>39.6 cm (15.6 in) High-Definition Plus (HD+) AntiGlare (AG) LED WVA (1600 x 900 resolution, 200nits, 60%CG)</p> <p>39.6 cm (15.6 in) FHD AG LED WVA (1920 x 1080 resolution, 220 nits, 60% CG)</p> <p>Display assembly (DreamColor):</p> <ul style="list-style-type: none"> • Supports privacy filter • Includes display panel cable, 3 WLAN antenna and cables, and 2 WWAN antenna and cables • Not available with HP Mobile Broadband <p>39.6 cm (15.6 in) FHD AG RGB LED UWVA Dream Color (1920 x 1080 resolution, 210 nits, 109% CG)</p> <p>39.6 cm (15.6 in) FHD AG RGB LED UWVA Dream Color with webcam (1920 x 1080 resolution, 210 nits, 109% CG)</p>
Memory	<p>In models that use quad-core processors, four SODIMM customer-accessible/upgradeable memory module slots supporting up to 32 GB of RAM</p> <p>In models that use dual-core processors, two SODIMM customer-accessible/upgradeable memory module slots supporting up to 16 GB of RAM</p> <p>PC3-12800, 1600-MHz, DDR3</p> <p>Supports dual-channel memory</p> <p>Supports the following configurations:</p> <ul style="list-style-type: none"> • 2048 MB Total System Memory (2048 x 1) • 4096 MB Total System Memory (4096 x 1) • 4096 MB Total System Memory (2048 x 2) • 8192 MB Total System Memory (8192 x 1) • 8192 MB Total System Memory (4096 x 2) • 8192 MB Total System Memory (2048 x 4) — only available with quad-core processors • 16384 MB Total System Memory (8192 x 2) • 16384 MB Total System Memory (4096 x 4) — only available with quad-core processors • 32768 MB Total System Memory (8192 x 4) — only available with quad-core processors

Category	Description	
Primary location hard drive	Customer-accessible	
	Supports RAID 0/1	
	Supports the following 7.0 mm, 9.5-mm SATA hard drives (6.35 cm (2.50 in))	
	<ul style="list-style-type: none"> • 750 GB, 7200 rpm • 500 GB, 7200 rpm • 500 GB, 7200 rpm Self Encrypting Drive • 320 GB, 7200 rpm 	
	Supports the following 6.35 cm (2.5 in) SATA III solid-state drives:	
	<ul style="list-style-type: none"> • 256 GB Self Encrypting Drive • 180 GB • 160 GB • 128 GB 	
	Upgrade bay	Fixed
		Customer-accessible
	Serial ATA	
	Supports 500 GB, 7200 rpm drive and 256 GB SSD Self Encrypting Drive	
	Supports the following 12.7 mm tray load optical drives:	
	<ul style="list-style-type: none"> • DVD-ROM Drive • DVD±RW and CD-RW SuperMulti Double Layer (DL) Drive • Blu-ray Disc ROM DVD±RW SuperMulti DL Combo Drive • Blu-ray Disc R/RE DVD±RW SuperMulti DL Drive 	
	Supports “No Drive” option	
Microphone	Integrated dual-array microphone	
Audio	HD Audio w/ SRS Premium Sound	
	Stereo speakers (2)	
Webcam	Integrated webcam (720p HD)	
Modem	56K V.92 MDC data/fax modem	
	Modem cable not included	
	Supports “No Modem” option	
Ethernet	Intel 82579LM 10/100/1000 network interface card (NIC), with iAMT	
	S3/S4/S5 wake on LAN	

Category	Description
Ethernet <i>(continued)</i>	NIC power down technology
	Ethernet cable not included
Wireless	Integrated WLAN options by way of wireless module:
	<ul style="list-style-type: none"> Broadcom 43228 802.11 a/b/g/n Wi-Fi 2x2 Adapter Intel Centrino Advanced N 6205 802.11 a/b/g/n 2x2 WiFi Adapter Intel Centrino Advanced-N 6205 Combo Adapter Intel Centrino Ultimate-N 6300 802.11 a/b/g/n 3x3 WiFi Adapter Intel Centrino Ultimate-N 6300 Combo Adapter
	Three WLAN antennas built into display assembly
	Supports “no WLAN” option
	Integrated WWAN options by way of wireless module:
	<ul style="list-style-type: none"> HP hs2350 HSPA+ Mobile Broadband Module HP lt2523 LTE/HSPA+ Mobile Broadband Module HP lt2522 LTE/EV-DO Mobile Broadband Module HP un2430 EV-DO/HSPA Mini Card HP un2430 EV-DO/HSPA Mobile Broadband Module
	Three WWAN antennas built into display assembly
	Subscriber identity module (SIM) security (customer-accessible in battery bay)
	Supports “no WWAN” option
	Integrated personal area network (PAN) options by way of Bluetooth® module:
HP Integrated Module with Bluetooth 2.1 Wireless Technology	
Supports “no WPAN” option	
External media card	One ExpressCard/54 slot
	Integrated Media Card Reader supports Secure Digital Card (SD), SD High Capacity (SDHC), SD eXtended-Capacity (SDXC), MultiMediaCard (MMC), and MMC <i>plus</i> (MMC+) formats
Ports	Audio-in (stereo microphone)
	Audio-out (stereo headphone)
	DisplayPort 1.2
	RJ-11 (modem)
	RJ-45 (Ethernet, includes link and activity lights)
	USB 3.0 (2)

Category	Description
Ports <i>(continued)</i>	USB 2.0 (2) (1 charging port)
	eSATA/USB 2.0 combo
	VGA (Dsub 15-pin)
	1394a
	Headphone Output (stereo)
	Docking connector
	Multi-pin AC
Docking	HP Docking Station
	HP Advanced Docking Station
Keyboard/pointing devices	Full-size keyboard with separate numeric keypad and TouchPad scroll zone
	Backlit full-size keyboard with separate numeric keypad and TouchPad scroll zone (select models only)
	Dual point (pointing stick and TouchPad) with 3 pointing stick buttons, 3 TouchPad buttons, and scroll zone
	Spill-resistant design, DuraKey coating
	Chemically strengthened glass cover on TouchPad
	Taps and gestures enabled by default: 2-finger scrolling, 2-finger zoom (pinch)
	Four launch buttons (Browser, wireless on/off, calculator, and mute volume)
Power requirements	AC adapter with localized cable plug support (3-wire plug with ground pin, supports 3-pin DC connector): <ul style="list-style-type: none"> • 200W SLIM Smart AC Adapter • 150W SLIM Smart AC Adapter • 120W SLIM Smart AC Adapter
	8-cell 2.8 Ah (83 Wh) Li-ion battery
	8-cell 2.8 Ah (75 Wh) Li-ion battery (1000 cycle 3 yr. warranty)
	Support for 9-cell (73 Wh) polymer HP ST09 Extended Life Battery (does not support HP Fast Charge)
	Support for 9-cell (100 Wh) cylindrical HP BB09 Ultra-Capacity Extended Life Battery (does not support HP Fast Charge)
	HP Fast Charge Technology
Security	Integrated fingerprint reader
	Full volume encryption
	Integrated smart card reader
	Security cable slot

Category	Description
Security <i>(continued)</i>	Trusted Platform Module (TPM) V.1.2 Preboot authentication (password, smart card)
Operating system	<p>Preinstalled:</p> <ul style="list-style-type: none"> Windows 8 Professional 64 with Microsoft Basics (Canada, Japan, and the United States only) Windows 8 Professional 64 DPK with Windows 7 Professional 64 and 32 (Canada, Japan, and the United States only) Windows 7 Home Premium 64 and 32 with Microsoft Basics (Asia/Pacific, Europe, and the United States only) Windows 7 Professional 64 and 32 with Microsoft Basics (Canada, Japan, and the United States only) Windows 7 Service Pack 1 FreeDOS (world-wide) <p>Preinstalled with Microsoft Office:</p> <ul style="list-style-type: none"> Windows 8 Professional 64 with Microsoft Office 2010 Transitional DPK (not supported in Japan) Windows 8 Professional 64 DPK with Windows 7 Professional 64 and 32 image with Microsoft Office 2010 Starter (not supported in Asia/Pacific, Japan, and the People's Republic of China) Windows 7 Professional 64 and 32 with Microsoft Office 2010 Starter (not supported in Japan) <p>Restore media—DRDVD:</p> <ul style="list-style-type: none"> Windows 8 (available with any Windows 8 loc, required with any Windows 7 Professional downgrade OS) Windows 7 (available with any Windows 7 or Windows 7 Professional downgrade loc) Red Hat Enterprise Linux (RHEL) 6.x 64-bit (available with FreeDOS and all Windows OS; available on the Web as an ISO) SuSE Linux Enterprise (SLED) Service Pack 2 64-bit (available with FreeDOS and all Windows OS; available on the Web as an ISO) <p>Restore media—OSDVD:</p> <ul style="list-style-type: none"> Windows 8 Professional 64 (available only and required with Windows 7 Professional downgrade OS) Windows 7 Home Premium 64 (available with Windows 7 Home Premium loc; not supported in Asia/Pacific or the People's Republic of China) Windows 7 Professional 64 and 32 (available with any Windows 7 Professional or Windows 7 Professional downgrade loc.; not supported in Asia/Pacific or the People's Republic of China)

Category	Description
Operating system <i>(continued)</i>	<p data-bbox="746 226 850 254">Certified:</p> <ul data-bbox="746 279 1265 415" style="list-style-type: none"> <li data-bbox="746 279 954 306">• Microsoft WHQL <li data-bbox="746 331 1185 359">• Red Hat Enterprise Linux (RHEL) 6.x 64-bit <li data-bbox="746 384 1265 411">• SuSE Linux Enterprise (SLED) Service Pack 2 64-bit <hr/> <p data-bbox="746 436 959 464">Web-only support:</p> <ul data-bbox="746 489 1406 846" style="list-style-type: none"> <li data-bbox="746 489 1054 516">• Windows 8 Professional 32 <li data-bbox="746 541 1110 569">• Windows 7 Enterprise 64 and 32 <li data-bbox="746 594 1098 621">• Windows 7 Ultimate 64 and 32 <li data-bbox="746 646 1142 674">• Windows XP Professional 64 and 32 <li data-bbox="746 699 1406 762">• Red Hat Enterprise Linux (RHEL) 6.x 64-bit (closed-source drivers/restore media (DRDVD ISO)) <li data-bbox="746 787 1406 846">• SuSE Linux Enterprise (SLED) Service Pack 2 64-bit (closed-source drivers/restore media (DRDVD ISO))
Serviceability	<p data-bbox="746 867 1054 894">End-user replaceable parts:</p> <p data-bbox="746 919 858 947">AC adapter</p> <p data-bbox="746 972 890 999">Battery (system)</p> <p data-bbox="746 1024 898 1052">Hard drive/SSD</p> <p data-bbox="746 1077 898 1104">Memory module</p> <p data-bbox="746 1129 874 1157">Optical drive</p> <p data-bbox="746 1182 1169 1209">Mini-PCI components (WLAN, WWAN, SIM)</p> <p data-bbox="746 1234 842 1262">Keyboard</p>

2 External Component Identification

Top

TouchPad

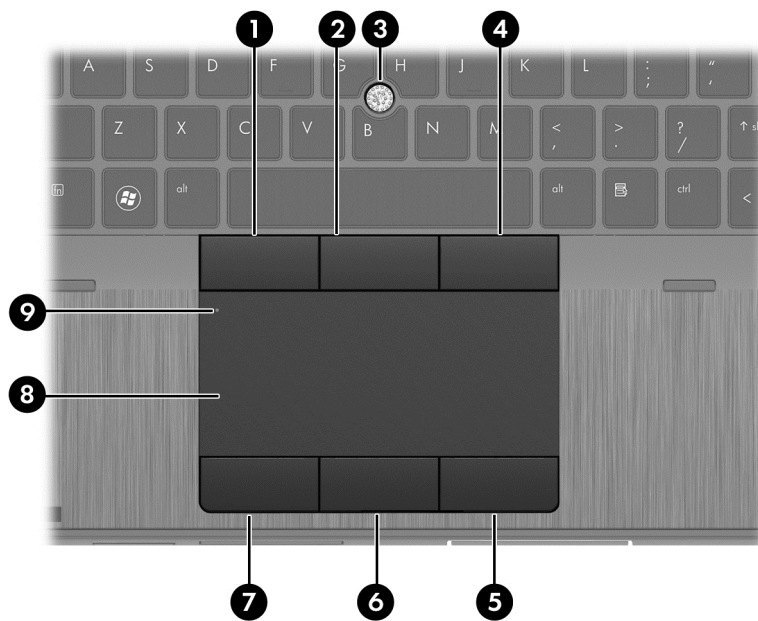





Component		Description
(1)	Left pointing stick button	Functions like the left button on an external mouse.
(2)	Center pointing stick button	Functions like the center button on an external mouse.
(3)	Pointing stick	Moves the pointer and selects or activates items on the screen.
(4)	Right pointing stick button	Functions like the right button on an external mouse.
(5)	Right TouchPad button	Functions like the right button on an external mouse.
(6)	Center TouchPad button	Functions like the center button on an external mouse.
(7)	Left TouchPad button	Functions like the left button on an external mouse.

Component		Description
(8)	TouchPad zone	Moves the pointer and selects or activates items on the screen.
(9)	TouchPad on/off button	Turns the TouchPad on and off when it is double-tapped.



Lights





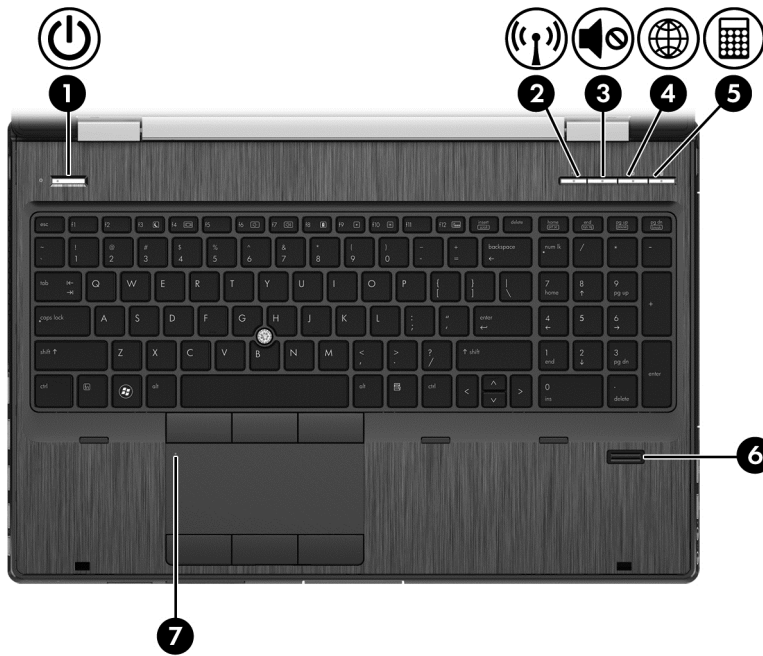

Component	Description
(1) TouchPad light	<ul style="list-style-type: none"> Amber: The TouchPad is off. Off: The TouchPad is on.
(2) Caps lock light	On: Caps lock is on.
(3)  Power light	<ul style="list-style-type: none"> On: The computer is on. Blinking: The computer is in the Sleep state. Off: The computer is off or in Hibernation.
(4) Num lk light	On: Num lk is on.
(5)  Wireless light	<ul style="list-style-type: none"> White: An integrated wireless device, such as a wireless local area network (WLAN) device and/or a Bluetooth® device, is on. Amber: All wireless devices are off.
(6)  Mute light	<ul style="list-style-type: none"> Amber: Computer sound is off. Off: Computer sound is on.
(7)  Web browser light	<ul style="list-style-type: none"> On: The computer is on. Off: The computer is off or in Hibernation.
(8)  Calculator light	<ul style="list-style-type: none"> On: The calculator function is on. Blinking: The calculator has been activated.

Buttons and fingerprint reader (select models only)





Component	Description
(1)  Power button	<ul style="list-style-type: none"> • When the computer is off, press the button to turn on the computer. • When the computer is on, press the button briefly to initiate Sleep. • When the computer is in the Sleep state, press the button briefly to exit Sleep. • When the computer is in Hibernation, press the button briefly to exit Hibernation. <p>CAUTION: Pressing and holding down the power button will result in the loss of unsaved information.</p> <p>If the computer has stopped responding and Microsoft® Windows® shutdown procedures are ineffective, press and hold the power button for at least 5 seconds to turn off the computer.</p> <p>To learn more about your power settings:</p> <ul style="list-style-type: none"> • Windows 8—From the Start screen, type <i>power</i>, select Settings, and then select Power Options. • Windows 7—Select Start > Control Panel > System and Security > Power Options. For more information, see the <i>HP Notebook Reference Guide</i>.
(2)  Wireless button	Turns the wireless feature on or off but does not establish a wireless connection.

Component	Description
(3)  Volume mute button	Mutes and restores speaker sound.
(4)  Web browser button	When Windows is running, press the button to open the default Web browser.
(5)  Calculator button	Activates the calculator function.
(6)  Fingerprint reader (select models only)	Allows a fingerprint logon to Windows, instead of a password logon.
(7) TouchPad on/off button	Turns the TouchPad on and off when it is double-tapped.

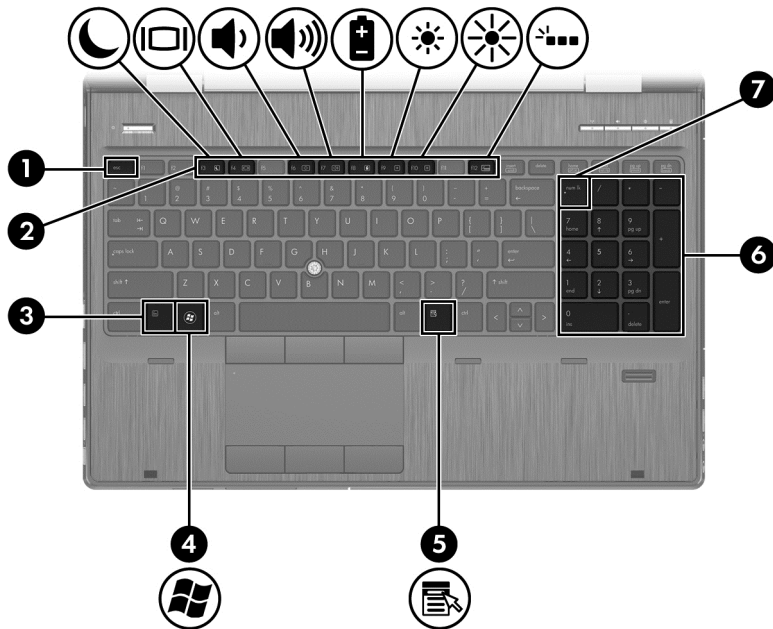



Keys

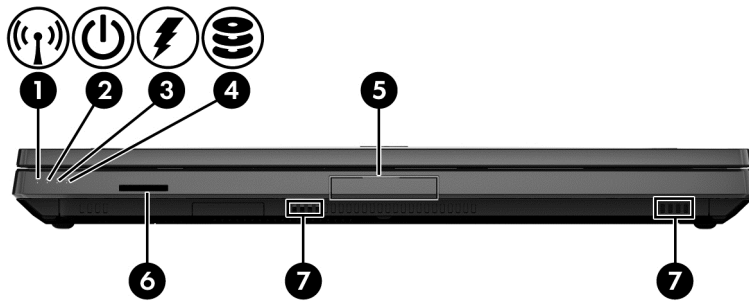

Component	Description
(1) <code>esc</code> key	Displays system information when pressed in combination with the <code>fn</code> key.
(2) Function keys	Execute frequently used system functions when pressed in combination with the <code>fn</code> key. .
(3) <code>fn</code> key	Executes frequently used system functions when pressed in combination with a function key, the <code>num lk</code> key, the <code>esc</code> key, or other keys.
(4)  Windows logo key	Displays the Windows Start menu.
(5)  Windows applications key	Displays a shortcut menu for items beneath the cursor.
(6) Integrated numeric keypad	When <code>num lk</code> has been enabled, it can be used like an external numeric keypad. To alternate between this numeric function and the navigational function (indicated by the directional arrows on the keys), press the <code>num lk</code> key.
(7) <code>num lk</code> key	Alternates between the navigational and numeric functions on the integrated numeric keypad.

Front





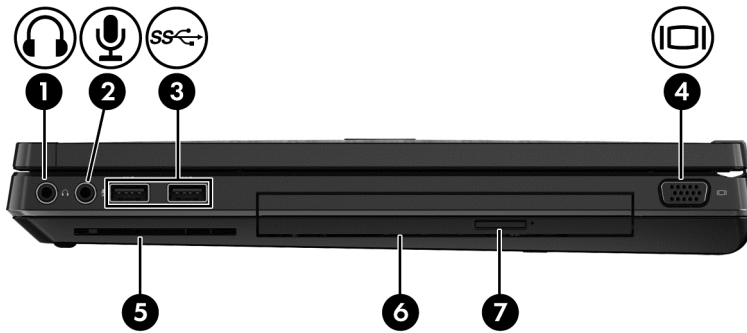

Component	Description
(1)  Wireless light	Turns the wireless feature on or off but does not establish a wireless connection.
(2)  Power light	<ul style="list-style-type: none"> On: The computer is on. Blinking: The computer is in the Sleep state. Off: The computer is off or in Hibernation.
(3)  AC adapter/Battery light	<ul style="list-style-type: none"> Amber: The computer is connected to external power and the battery is charged from 0 to 90 percent. White: The computer is connected to external power and the battery is charged from 90 to 99 percent. Blinking amber: A battery that is the only available power source has reached a low battery level. When the battery reaches a critical battery level, the battery light begins blinking rapidly. Off: The battery is fully charged.
(4)  Hard drive light	<ul style="list-style-type: none"> Blinking white: The hard drive is being accessed. Amber: HP 3D DriveGuard has temporarily parked the hard drive. <p>NOTE: For information on HP 3D DriveGuard, see the <i>HP Notebook Reference Guide</i>.</p>
(5) Display release latch	Opens the computer.

Component	Description
(6) Media Card Reader	<p>Supports the following digital card formats:</p> <ul style="list-style-type: none"> • MultiMediaCard • MultiMediaCardplus (MMC+) • Secure Digital (SD) Card • Secure Digital HC (SDHC) Card • Secure Digital XC (SDXC) Card
(7) Speakers (2)	<p>Produce SRS Premium Sound (select models only).</p> <p>NOTE: To use the SRS Premium Sound software:</p> <ul style="list-style-type: none"> • Windows 8—From the Start screen, type <i>SRS</i>, and then select SRS Premium Sound. • Windows 7—Select Start > All Programs > SRS Premium Sound.







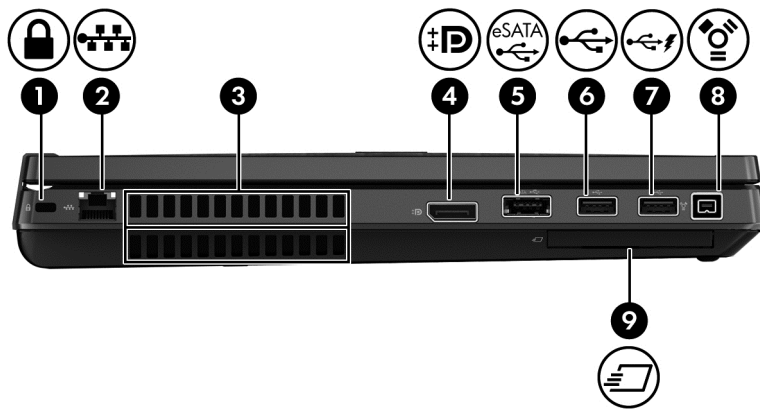

Right



Component	Description
(1)  Audio-out (headphone) jack	Produces sound when connected to optional powered stereo speakers, headphones, earbuds, a headset, or television audio. WARNING! To reduce the risk of personal injury, adjust the volume before putting on headphones, earbuds, or a headset. For additional safety information, see the <i>Regulatory, Safety, and Environmental Notices</i> . NOTE: When a device is connected to the jack, the computer speakers are disabled.
(2)  Audio-in (microphone) jack	Connects an optional computer headset microphone, stereo array microphone, or monaural microphone.
(3)  USB 3.0 ports (2)	Connect optional USB 3.0 compatible devices and provide enhanced USB power performance.
(4)  External monitor port	Connects an external VGA monitor or projector.
(5) Smart card reader	Supports optional smart cards.
(6) Upgrade bay (optical drive shown)	The upgrade bay can hold a protective insert, a hard drive, or an optical drive that reads an optical disc. NOTE: On select models, the optical drive also writes to an optical disc.
(7) Optical drive eject button (select models only)	Releases the disc tray.



Left

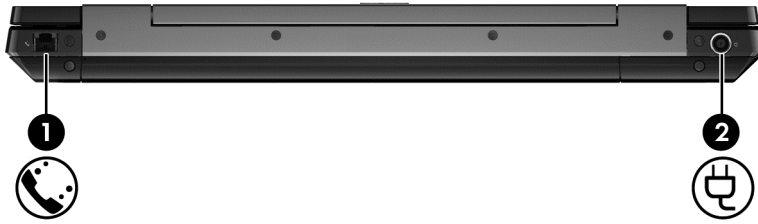

Component	Description
(1) 	Security cable slot Attaches an optional security cable to the computer. NOTE: The security cable is designed to act as a deterrent, but it may not prevent the computer from being mishandled or stolen.
(2) 	RJ-45 (network) jack Connects a network cable.
(3)	Vents (2) Enable airflow to cool internal components. NOTE: The computer fan starts up automatically to cool internal components and prevent overheating. It is normal for the internal fan to cycle on and off during routine operation.
(4) 	DisplayPort Connects an optional digital display device, such as a high-performance monitor or projector.
(5) 	eSATA/USB 2.0 combo port Connects an optional high-performance eSATA component, such as an eSATA external hard drive, or connects an optional USB device.
(6) 	USB 2.0 port Connects an optional USB device. For more information about USB devices, see the <i>HP Notebook Reference Guide</i> .
(7) 	USB charging port Connects an optional USB 2.0 compatible device
(8) 	1394 port Connects an optional IEEE 1394 or 1394a device, such as a camcorder.
(9) 	HP ExpressCard slot Supports optional ExpressCards.

Rear



Component		Description	
(1)		RJ-11 (modem) jack	Connects a modem cable.
(2)		Power connector	Connects an AC adapter.

Display

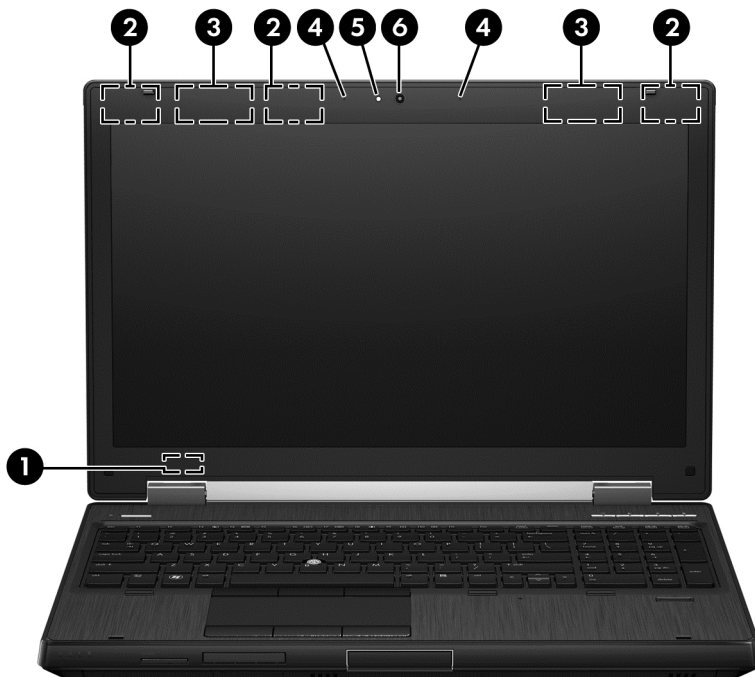



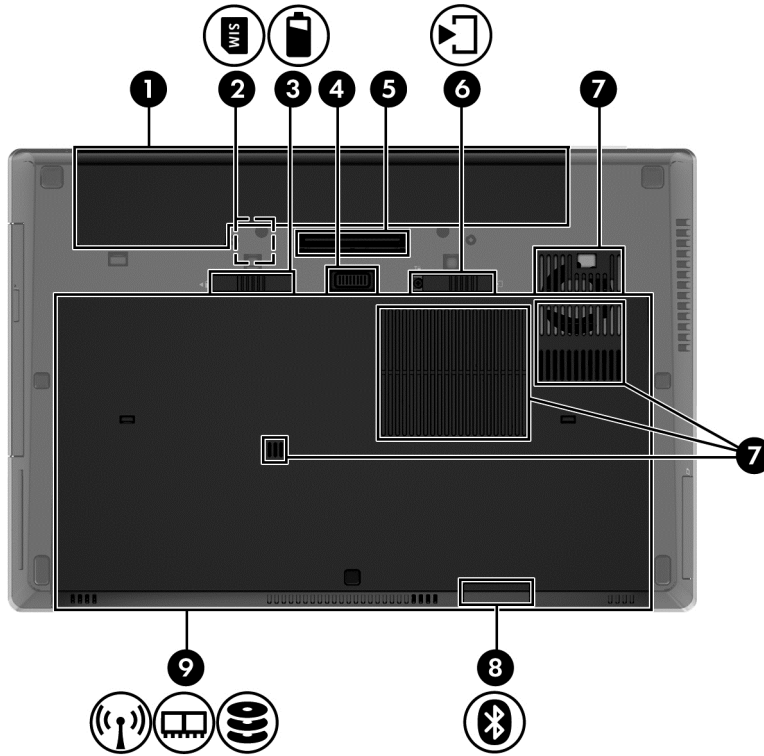

Component	Description
(1) Internal display switch	Turns off the display or initiates Sleep if the display is closed while the power is on. NOTE: The display switch is not visible from the outside of the computer.
(2) WLAN antennas (3)*	Send and receive wireless signals to communicate with wireless local area networks (WLAN).
(3) WWAN antennas (2)*	Send and receive wireless signals to communicate with wireless wide area networks (WWAN).
(4) Internal microphones (2)	Record sound.
(5) Webcam light (select models only)	On: The webcam is in use.
(6) Webcam (select models only)	Records video and captures still photographs. To use the webcam: <ul style="list-style-type: none"> Windows 8—From the Start screen, type <i>h</i>, and then select Help and Support. Windows 7—Select Start > All Programs > Communication and Chat > HP Webcam.

*The antennas are not visible from the outside of the computer. For optimal transmission, keep the areas immediately around the antennas free from obstructions. To see wireless regulatory notices, see the section of the *Regulatory, Safety, and Environmental Notices* that applies to your country or region. These notices are located in Help and Support.

Bottom

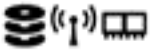

Component	Description
(1)	Battery bay Holds the battery.
(2) 	SIM slot Supports a wireless subscriber identity module (SIM). The SIM slot is located inside the battery bay.
(3) 	Battery release latch Releases the battery.
(4)	Accessory battery connector Connects an optional accessory battery.
(5)	Docking connector Connects an optional docking device.
(6) 	Service door release latch Releases the service door from the computer.
(7)	Vents (4) Enable airflow to cool internal components. NOTE: The computer fan starts up automatically to cool internal components and prevent overheating. It is normal for the internal fan to cycle on and off during routine operation.

Component	Description
(8) 	Bluetooth compartment Contains a Bluetooth device (select models only).
(9) 	Service door Provides access to the hard drive, the wireless LAN (WLAN) module slot, the WWAN module slot, and the memory module slots. CAUTION: To prevent an unresponsive system, replace the wireless module only with a wireless module authorized for use in the computer by the governmental agency that regulates wireless devices in your country or region. If you replace the module and then receive a warning message, remove the module to restore computer functionality, and then contact technical support through Help and Support.

3 Illustrated parts catalog

Service tag

When ordering parts or requesting information, provide the computer serial number and model description provided on the service tag.

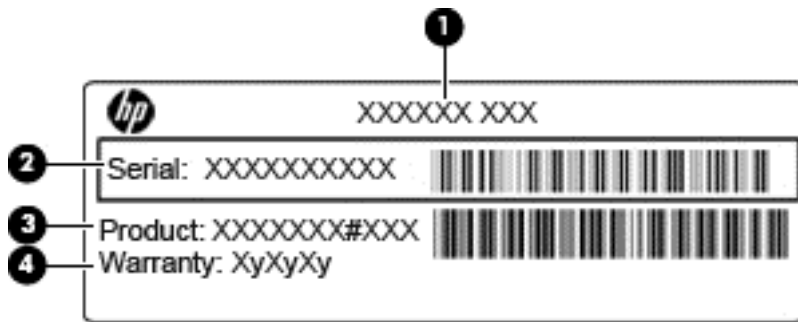

Item	Description	Function
(1)	Product name	The name affixed to the front of the computer.
(2)	Serial number (s/n)	This is an alphanumeric identifier that is unique to each product.
(3)	Part number/Product number (p/n)	This number provides specific information about the product's hardware components. The part number helps a service technician to determine what components and parts are needed.
(4)	Warranty period	This number describes the duration of the warranty period for the computer.

Computer major components

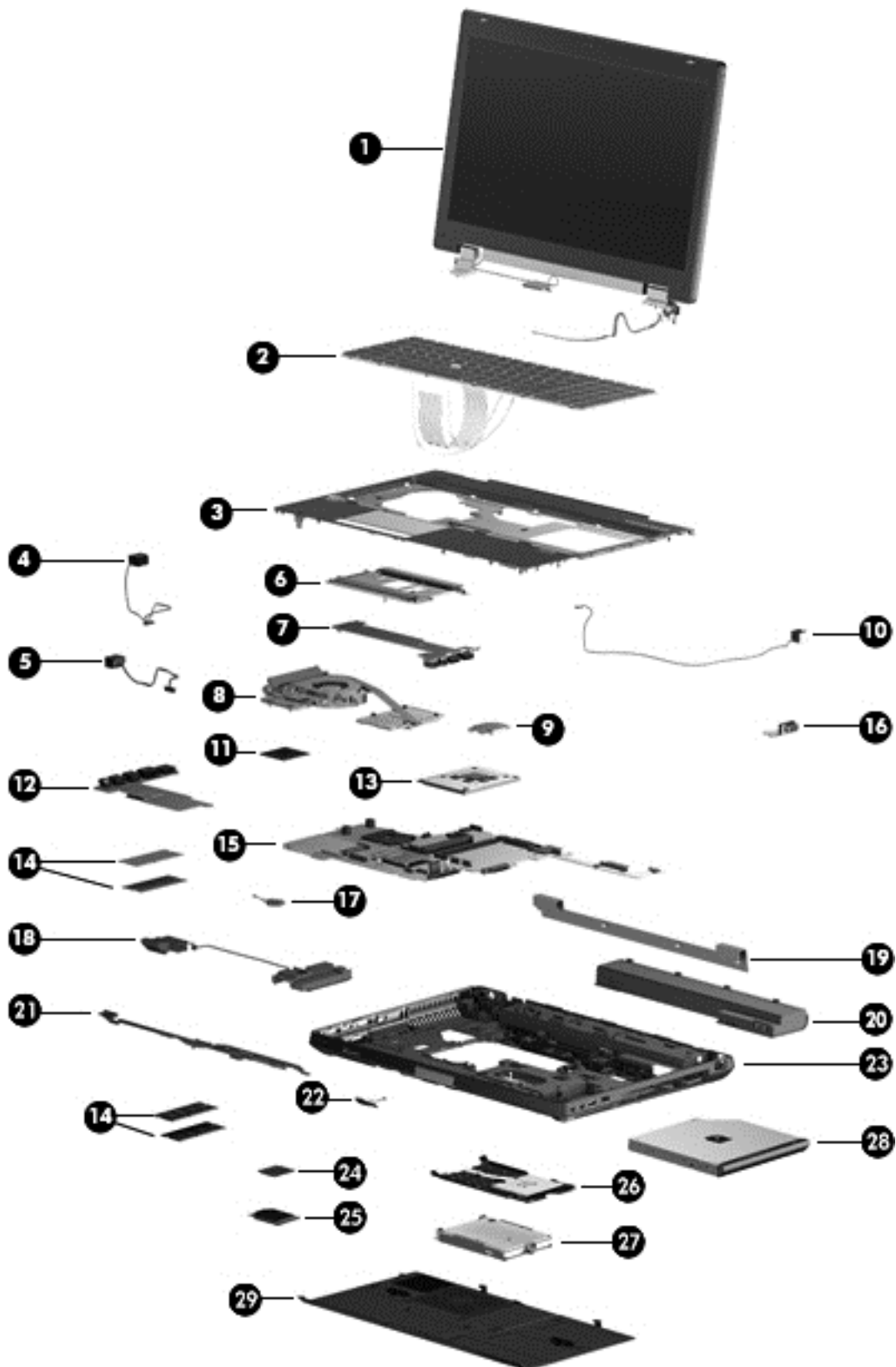

Item	Description	Spare part number
(1)	39.6-cm (15.6 in) FHD RGB UWVA LCD display assembly with DreamColor	
	For use in computer models without webcams	653277-001
	For use in computer models with webcams	653278-001
(2)	Keyboard with numeric keypad and pointing stick (includes keyboard cable and pointing stick cable):	
	Keyboard with backlight for use only on computer models equipped with the Windows 8 operating system (includes backlight cable):	
	For use in Belgium	703149-A41
	For use in Canada	703149-DB1
	For use in the Czech Republic and Slovakia	703149-FL1
	For use in Denmark	703149-081
	For use in France	703149-051
	For use in Germany	703149-041
	For use in India	703149-D61
	For use in Italy	703149-061
	For use in Latin America	703149-161
	For use in the Netherlands	703149-B31
	For use in Norway	703149-091
	For use in Russia	703149-251
	For use in South Korea	703149-AD1
	For use in Sweden and Finland	703149-B71
	For use in Switzerland	703149-BG1
	For use in Taiwan	703149-AB1
	For use in Thailand	703149-281
	For use in the United Kingdom and Singapore	703149-031
	For use in the United States	703149-001
	Keyboard without backlight for use only on computer models equipped with the Windows 8 operating system:	
	For use in Belgium	703151-A41
	For use in Brazil	703151-201
	For use in Bulgaria	703151-261
	For use in Canada	703151-DB1
	For use in the Czech Republic and Slovakia	703151-FL1
	For use in Denmark	703151-081

Item	Description	Spare part number
	For use in France	703151-051
	For use in Germany	703151-041
	For use in Greece	703151-151
	For use in Hungary	703151-211
	For use in Iceland	703151-DD1
	For use in India	703151-D61
	For use in Israel	703151-BB1
	For use in Italy	703151-061
	For use in Japan	703151-291
	For use in Latin America	703151-161
	For use in the Netherlands	703151-B31
	For use in Norway	703151-091
	For use in Northwest Africa	703151-FP1
	For use in Portugal	703151-131
	For use in Romania	703151-271
	For use in Russia	703151-251
	For use in Saudi Arabia	703151-171
	For use in Slovenia	703151-BA1
	For use in South Korea	703151-AD1
	For use in Spain	703151-071
	For use in Sweden and Finland	703151-B71
	For use in Switzerland	703151-BG1
	For use in Taiwan	703151-AB1
	For use in Thailand	703151-281
	For use in Turkey	703151-141
	For use in the United Kingdom and Singapore	703151-031
	For use in the United States	703151-001
	Keyboard with backlight for use only on computer models equipped with the Windows 7 operating system (includes backlight cable):	
	For use in Belgium	690647-A41
	For use in the Canada	690647-DB1
	For use in the Czech Republic and Slovakia	690647-FL1

Item	Description	Spare part number
	For use in Denmark	690647-081
	For use in France	690647-051
	For use in Germany	690647-041
	For use in India	690647-D61
	For use in Italy	690647-061
	For use in Latin America	690647-161
	For use in the Netherlands	690647-B31
	For use in Norway	690647-091
	For use in Russia	690647-251
	For use in South Korea	690647-AD1
	For use in Sweden and Finland	690647-B71
	For use in Switzerland	690647-BG1
	For use in Taiwan	690647-AB1
	For use in Thailand	690647-281
	For use in the United Kingdom and Singapore	690647-031
	For use in the United States	690647-001
	Keyboard without backlight for use only on computer models equipped with the Windows 7 operating system:	
	For use in Belgium	690648-A41
	For use in Brazil	690648-201
	For use in Bulgaria	690648-261
	For use in Canada	690648-DB1
	For use in the Czech Republic and Slovakia	690648-FL1
	For use in Denmark	690648-081
	For use in France	690648-051
	For use in Germany	690648-041
	For use in Greece	690648-151
	For use in Hungary	690648-211
	For use in Iceland	690648-DD1
	For use in India	690648-D61
	For use in Israel	690648-BB1
	For use in Italy	690648-061
	For use in Japan	690648-291

Item	Description	Spare part number
	For use in Latin America	690648-161
	For use in the Netherlands	690648-B31
	For use in Norway	690648-091
	For use in Northwest Africa	690648-FP1
	For use in Portugal	690648-131
	For use in Romania	690648-271
	For use in Russia	690648-251
	For use in Saudi Arabia	690648-171
	For use in Slovenia	690648-BA1
	For use in South Korea	690648-AD1
	For use in Spain	690648-071
	For use in Sweden and Finland	690648-B71
	For use in Switzerland	690648-BG1
	For use in Taiwan	690648-AB1
	For use in Thailand	690648-281
	For use in Turkey	690648-141
	For use in the United Kingdom and Singapore	690648-031
	For use in the United States	690648-001
(3)	Top cover (includes TouchPad button and bracket)	690645-001
(4)	Power connector (included in the cable kit, spare part number 690623-001. For information about cable kit contents, see Cable Kit on page 33.)	
(5)	RJ-45 (network) jack (included in the cable kit, spare part number 690623-001. For information about cable kit contents, see Cable Kit on page 33.)	
(6)	TouchPad button board (included with top cover, spare part number 690645-001)	
(7)	Audio/USB 3.0 board	690636-001
(8)	Fan and heat sink assembly	
	For use in computers with AMD FirePro M4000 graphics cards	690628-001
	use in computers with NVIDIA Quadro K2000M graphics cards	690630-001
	For use in computers with NVIDIA Quadro K1000M graphics cards	690629-001
(9)	Modem module (56k v.92 MDC data/fax modem)	628824-001
(10)	RJ-11 (modem) jack (included in the cable kit, spare part number 690623-001. For information about cable kit contents, see Cable Kit on page 33.)	
(11)	Processor	

Item	Description	Spare part number
	Intel Quad Core i7-3840QM 2.80-GHz processor (SC turbo up to 3.80-GHz; 1600-MHz FSB, 8.0-MB L3 cache, 45 W)	703266-002
	i7-3820QM, 2.70 GHz (Turbo up to 3.70 GHz), quad-core processor, 1600 MHz, 8 MB L3 Cache, 8 threads, 45W	681284-002
	Intel Quad Core i7-3740QM 2.70-GHz processor (SC turbo up to 3.70-GHz; 1600-MHz FSB, 6.0-MB L3 cache, 45 W)	702840-002
	i7-3720QM, 2.60GHz (Turbo up to 3.60 GHz), quad-core processor, 1600 MHz, 6 MB L3 Cache, 8 threads, 45W	681283-002
	Intel Quad Core i7-3630QM 2.40-GHz processor (SC turbo up to 3.40-GHz; 1600-MHz FSB, 6.0-MB L3 cache, 45 W)	702081-002
	i7-3610QM, 2.30 GHz (Turbo up to 3.30 GHz), quad-core processor 1600 bMHz, 6MB L3 Cache, 8 threads, 45W	680646-002
	i7-3520M, 2.90GHz (Turbo up to 3.60 GHz), dual-core processor, 1600 MHz, 4MB L3 Cache, 4 threads, 35W	681954-002
	i5-3360M, 2.80 GHz (Turbo up to 3.50 GHz), dual-core processor, 1600 MHz, 3 MB L3 Cache, 4 threads, 35W	681953-002
	i5-3320M, 2.60 GHz (Turbo up to 3.30 GHz), dual-core processor, 1600 MHz, 3 MB L3 Cache, 4 threads, 35W	681952-002
(12)	ExpressCard/USB 2.0 assembly board	684793-001
(13)	Graphics card (includes replacement thermal material)	
	NVIDIA Quadro K2000M (NVIDIA N14P-Q3 2GB DDR3)	690637-001
	NVIDIA Quadro K1000M (NVIDIA N14P-Q1 2GB DDR3)	690638-001
	AMD FirePro M4000 (Chelsea XT GL 1GB GDDR5)	690639-001
(14)	Memory modules	
	8 GB (DDR3 1600 MHz PC3-12800)	670034-001
	4 GB (DDR3 1600 MHz PC3-12800)	641369-001
	2 GB (DDR3 1600 MHz PC3-12800)	652972-001
(15)	System board (includes replacement thermal material)	
	For use with quad-core processors and the Windows 8 Professional operating system in all countries except China and Russia	690643-601
	For use with quad-core processors and the Windows 8 Standard operating system in all countries except China and Russia	690643-501
	For use with quad-core processors and the Windows 7 operating system in all countries except China and Russia	690643-001
	For use with quad-core processors in China and Russia only	696441-001
	For use with dual-core processors and the Windows 8 Professional operating system in all countries except China and Russia	690642-601

Item	Description	Spare part number
	For use with dual-core processors and the Windows 8 Standard operating system in all countries except China and Russia	690642-501
	For use with dual-core processors and the Windows 7 operating system in all countries except China and Russia	690642-001
	For use with dual-core processors in China and Russia only	696440-001
(16)	VGA port	690640-001
(17)	RTC battery	652650-001
(18)	Speakers	652669-001
(19)	Display hinge cover (includes Hewlett Packard logo)	652657-001
(20)	Battery	
	8-cell Li-ion 83-Wh battery	632427-001
	8-cell Li-ion 75-Wh battery	632425-001
	9-cell Li-ion 73-Wh extended life battery	634089-001
	9-cell Li-ion 100-Wh ultra-capacity extended life battery	634087-001
(21)	Display latch	652647-001
(22)	Bluetooth module	655792-001
	NOTE: The Bluetooth module spare part kit does not include a Bluetooth module cable. The Bluetooth module cable is included in the cable kit, spare part number 690623-001. For information about cable kit contents, see Cable Kit on page 33 .	
(23)	Base enclosure	698946-001
(24)	WLAN module	
	Broadcom 43228 802.11 a/b/g/n Wi-Fi 2x2 Adapter	669832-001
	Intel Centrino Advanced N 6205 802.11 a/b/g/n 2x2 WiFi Adapter	631954-001
	Intel Centrino Advanced-N 6205 Combo Adapter	695915-001
	Intel Centrino Ultimate-N 6300 802.11 a/b/g/n 3x3 WiFi Adapter	572511-001
	Intel Centrino Ultimate-N 6300 Combo Adapter	698588-001
(25)	WWAN module	
	HP hs2350 HSPA+ Mobile Broadband Module	668969-001
	HP lt2523 LTE/HSPA+ Mobile Broadband Module	675793-001
	HP lt2522 LTE/EV-DO Mobile Broadband Module	710789-001
	HP un2430 EV-DO/HSPA Mini Card	702080-001
	HP un2430 EV-DO/HSPA Mobile Broadband Module	634400-001
(26)	Smart card reader (includes door and cable)	652672-001

Item	Description	Spare part number
(27)	Hard drive	
	750 GB, 7200 rpm	633252-001
	500 GB, 7200 rpm	634925-001
	500 GB, 7200 rpm , Self Encrypting hard drive (SED)	683801-001
	320 GB, 7200 rpm, 7-mm	634862-001
	Solid-state drive	
	256 GB SATA III solid-state drive (SSD) SED	694683-001
	180 GB SATA II SSD	694684-001
	160 GB SATA II SSD	694685-001
	128 GB SATA III SSD	653434-001
	128 GB SATA III SSD locked	705053-001
	Hard Drive Hardware Kit (includes hard drive bracket and screws)	644694-001
(28)	Upgrade bay device	
	DVD-ROM Drive	694687-001
	DVD±RW and CD-RW SuperMulti DL Combo Drive	694688-001
	Blu-ray Disc ROM DVD±RW SuperMulti DL Combo Drive	694689-001
	Blu-ray Disc R/RE DVD±RW SuperMulti DL Drive	694690-001
	Upgrade bay bezel (not illustrated)	655547-001
(29)	Service door (with feet)	652648-001
	Cable kit (not illustrated). For information about cable kit contents, see Cable Kit on page 33 .	690623-001

Display components

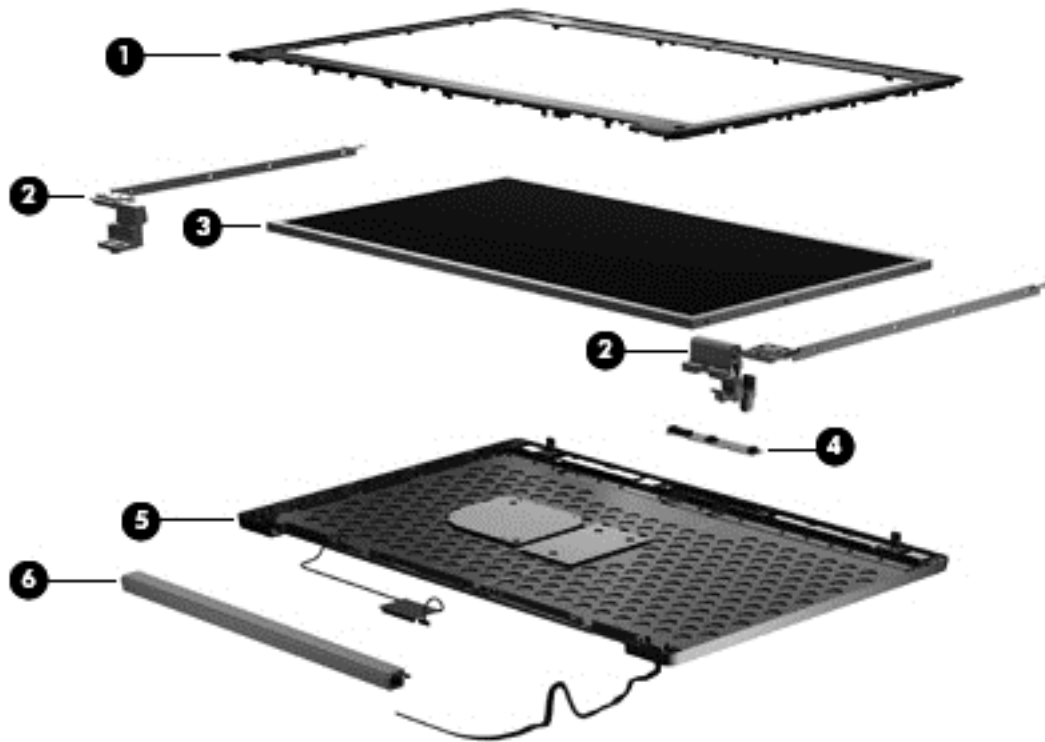

Item	Description	Spare part number
(1)	Display bezel	
	For use on computer models with a webcam	690621-001
	For use on computer models without a webcam	690622-001
(2)	Display hinges (includes left and right hinges)	652646-001
(3)	39.6-cm (15.6 in) display panel	
	HD+ WVA display panel	690644-001
	FHD WVA display panel	694681-001
(4)	Webcam module	699687-001
(5)	Display cover (included in raw panel support kit, spare part number 690632-001)	
	HP Logo Kit (not illustrated, includes cables)	652666-001
(6)	Cable routing tray (included with the plastics kit, spare part number 684794-001)	
	WLAN antennas and cables (not illustrated, included in the cable kit, spare part number 690623-001. For information about cable kit contents, see Cable Kit on page 33.)	
	WWAN antennas and cables (not illustrated, included in the cable kit, spare part number 690623-001. For information about cable kit contents, see Cable Kit on page 33.)	

Plastics Kit

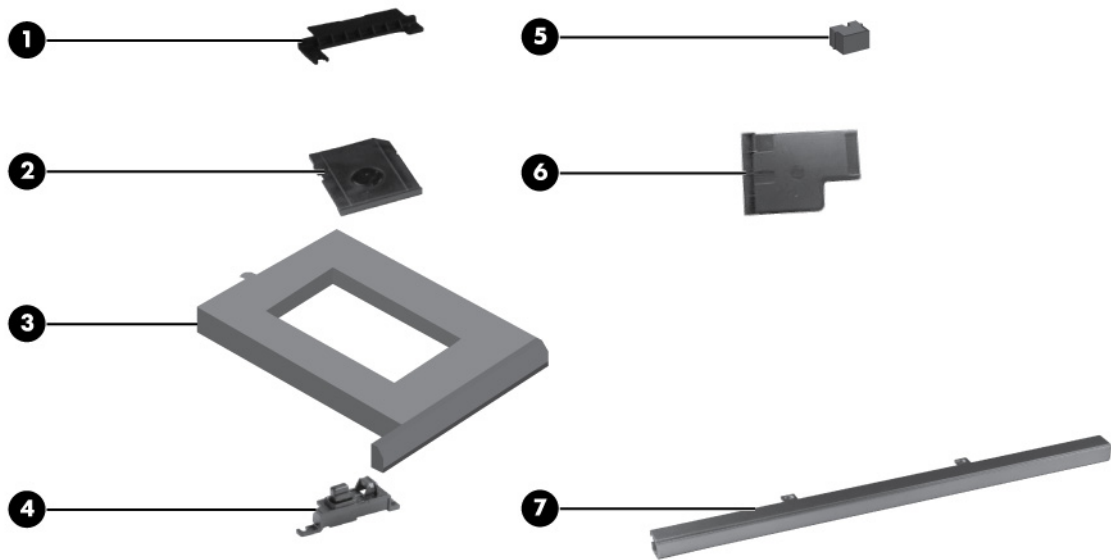

Item	Description	Spare part number
Plastics Kit:		652664-001
(1)	Battery cover	
(2)	SD Card blank	
(3)	Optical drive weight saver	
(4)	Display latch button	
(5)	RJ-11 jack cover	
(6)	ExpressCard blank	
(7)	Inverter cover (2 are included, one for models with DreamColor and one for models without DreamColor)	

Cable Kit

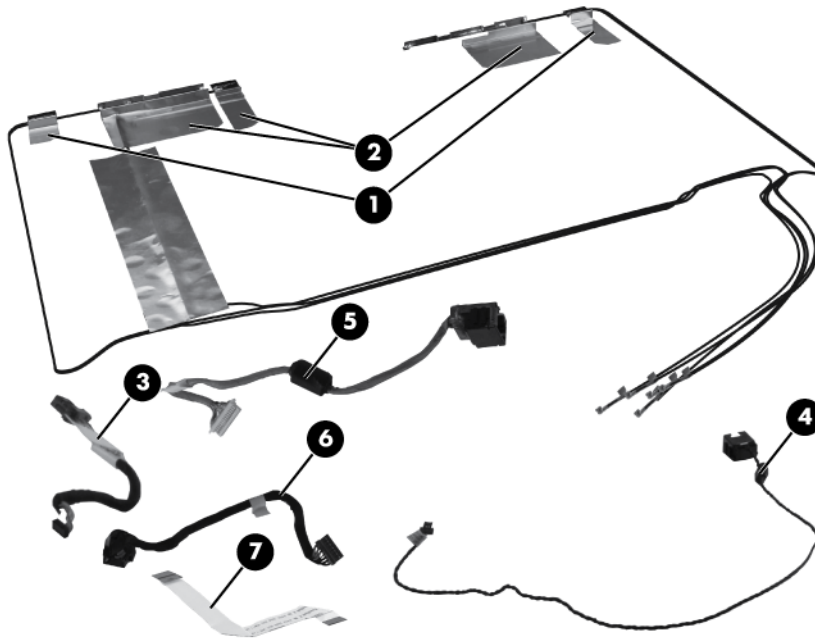

Item	Description	Spare part number
Cable Kit:		690623-001
(1)	WWAN antenna	
(2)	WLAN antenna	
(3)	Bluetooth module cable	
(4)	RJ11 connector cable	
(5)	RJ45 connector cable	
(6)	Power connector cable	
(7)	TouchPad cable	

Mass storage devices



Item	Description	Spare part number
(1)	Optical drive	
	DVD±RW and CD-RW SuperMulti DL Combo Drive	653020-001
	Blu-ray Disc R/RE DVD±RW SuperMulti DL Drive	653022-001
	DVD-ROM Drive	653019-001
	Blu-ray Disc ROM DVD±RW SuperMulti DL Combo Drive	653021-001
(2)	Hard drive	
	750 GB, 7200 rpm	633252-001
	500 GB, 7200 rpm	634925-001
	500 GB, 7200 rpm , Self Encrypting hard drive (SED)	683801-001
	320 GB, 7200 rpm, 7-mm	634862-001
	Hard Drive Hardware Kit (includes hard drive bracket and screws)	644694-001
	Solid-state drive (not illustrated)	
	256 GB SATA III SSD SED	694683-001
	180 GB SATA II SSD	694684-001
	160 GB SATA II SSD	694685-001
	128 GB SATA III SSD	653434-001
	Upgrade bay bezel (not illustrated, included in Plastics Kit, spare part number 684794-001)	

Miscellaneous parts

Description	Spare part number
AC adapters	
200-W AC adapter	693708-001
150-W AC adapter	693707-001
120-W AC adapter	645156-001
Power cord, 3-pin	
For use in Argentina	490371-D01
For use in Australia	490371-011
For use in Brazil	490371-202
For use in Bulgaria	490371-021
For use in Denmark	490371-081
For use in India	490371-D61
For use in Israel	490371-BB1
For use in Japan	490371-291
For use in the People's Republic of China	490371-AA1
For use in South Africa	490371-AR1
For use in South Korea	490371-AD1
For use in Switzerland	490371-111
For use in Taiwan	490371-AB1
For use in Thailand	490371-201
For use in the United Kingdom and Singapore	490371-031
For use in the United States	490371-001
Power cord, 3-prong	
For use in Argentina	491683-D01
For use in Asia/Pacific countries and regions	491683-D91
For use in Australia	491683-011
For use in Brazil	491683-202
For use in Denmark	491683-081
For use in Europe, the Middle East, and Africa	491683-021
For use in India	491683-D61
For use in Israel	491683-BB1

Description	Spare part number
For use in Japan	491683-291
For use in North America	491683-001
For use in the People's Republic of China	491683-AA1
For use in Saudi Arabia	491683-171
For use in South Africa	491683-AR1
For use in South Korea	491683-AD1
For use in Switzerland	491683-111
For use in Taiwan	491683-AB1
For use in Thailand	491683-201
For use in the United Kingdom and Singapore	491683-031
Rubber Kit (includes rubber feet and rubber screw covers)	652663-001
Mouse	390632-001
Optical travel mouse	434594-001
Notebook combination lock	591699-001
Case , professional slim top load	592923-001
Screw Kit	652661-001

Sequential part number listing

Spare part number	Description
390632-001	Mouse
434594-001	Optical travel mouse
490371-001	Power cord for use in North America (3-pin)
490371-011	Power cord for use in Australia (3-pin)
490371-021	Power cord for use in Europe, the Middle East, and Africa (3-pin)
490371-031	Power cord for use in the United Kingdom and Singapore (3-pin)
490371-081	Power cord for use in Denmark (3-pin)
490371-111	Power cord for use in Switzerland (3-pin)
490371-201	Power cord for use in Thailand (3-pin)
490371-202	Power cord for use in Brazil (3-pin)
490371-291	Power cord for use in Japan (3-pin)
490371-AA1	Power cord for use in the People's Republic of China (3-pin)
490371-AB1	Power cord for use in Taiwan (3-pin)
490371-AD1	Power cord for use in South Korea (3-pin)
490371-AR1	Power cord for use in South Africa (3-pin)
490371-BB1	Power cord for use in Israel (3-pin)
490371-D01	Power cord for use in Argentina (3-pin)
490371-D61	Power cord for use in India (3-pin)
490371-D91	Power cord for use in AsiaPacific (3-pin)
491683-001	Power cord for use in North America (3-prong)
491683-011	Power cord for use in Australia (3-prong)
491683-021	Power cord for use in Europe, the Middle East, and Africa (3-prong)
491683-031	Power cord for use in the United Kingdom and Singapore (3-prong)
491683-081	Power cord for use in Denmark (3-prong)
491683-111	Power cord for use in Switzerland (3-prong)
491683-171	Power cord for use in Saudi Arabia (3-prong)
491683-201	Power cord for use in Thailand (3-prong)
491683-202	Power cord for use in Brazil (3-prong)
491683-291	Power cord for use in Japan (3-prong)
491683-AA1	Power cord for use in the People's Republic of China (3-prong)

Spare part number	Description
491683-AB1	Power cord for use in Taiwan (3-prong)
491683-AD1	Power cord for use in South Korea (3-prong)
491683-AR1	Power cord for use in South Africa (3-prong)
491683-BB1	Power cord for use in Israel (3-prong)
491683-D01	Power cord for use in Argentina (3-prong)
491683-D61	Power cord for use in India (3-prong)
491683-D91	Power cord for use in Asia Pacific (3-prong)
572511-001	Intel Centrino Ultimate-N 6300 802.11 3x3 a/g/n WiFi Adapter
591699-001	Notebook combination lock
592923-001	Case, professional slim top load
626729-002	HP Keyed cable lock
628824-001	56k v.92 MDC data/fax modem module
631954-001	Intel Centrino Advanced N 6205, 2x2 a/b/g/n WiFi Adapter
632425-001	8-cell, 2.8-Ah (75-Wh) Li-ion battery
632427-001	8-cell, 2.8-Ah (83-Wh) Li-ion battery
633252-001	750 GB, 7200 rpm hard drive (includes hard drive bracket and screws)
634087-001	9-cell, 3.0-Ah (100-Wh) Li-ion ultra-capacity extended life battery
634089-001	9-cell, 2.8-Ah (73-Wh) Li-ion extended life battery
634400-001	HP un2430 EV-DO/HSPA Mobile Broadband Module
634862-001	320 GB, 7200 rpm hard drive (includes hard drive bracket and screws)
634925-001	500 GB, 7200 rpm hard drive (includes hard drive bracket and screws)
641369-001	4 GB PC3-12800, 1600 MHz, DDR3
644694-001	Hard Drive Hardware Kit
647600-001	Board, MIC B series
652646-001	Display hinges (includes left and right hinges)
652647-001	Display latch with hook
652648-001	Service door
652650-001	RTC battery
652657-001	Display hinge cover (includes Hewlett Packard logo)
652661-001	Screw Kit
652663-001	Rubber Kit (includes rubber feet and rubber screw covers)
652666-001	HP Logo Kit (includes cables)

Spare part number	Description
652669-001	Speakers
652672-001	Smart card reader (includes door and cable)
652684-001	Pointing stick cover
652685-001	PCH thermal material
652687-001	Smart card bracket
652972-001	2 GB PC3-12800, 1600 MHz, DDR3
655547-001	Drive upgrade bay
655792-001	HP Integrated Module with Bluetooth 2.1 Wireless Technology
668969-001	HP hs2350 HSPA+ Mobile Broadband Module
669832-001	Broadcom 43228 802.11a/b/g/n 2x2 Wi-Fi Adapter
670034-001	8 GB PC3-12800, 1600 MHz, DDR3
675791-001	HP lt2522 LTE/EV-DO Mobile Broadband Module
675793-001	HP lt2523 LTE/HSPA+ Mobile Broadband Module
680646-002	i7-3610QM, 2.30 GHz (Turbo up to 3.30 GHz), quad-core processor 1600 MHz, 6MB L3 Cache, 8 threads, 45W
681283-002	i7-3720QM, 2.60GHz (Turbo up to 3.60 GHz), quad-core processor, 1600 MHz, 6 MB L3 Cache, 8 threads, 45W
681284-002	i7-3820QM, 2.70 GHz (Turbo up to 3.70 GHz), quad-core processor, 1600 MHz, 8 MB L3 Cache, 8 threads, 45W
681952-002	i5-3320M, 2.60 GHz (Turbo up to 3.30 GHz), dual-core processor, 1600 MHz, 3 MB L3 Cache, 4 threads, 35W
681953-002	i5-3360M, 2.80 GHz (Turbo up to 3.50 GHz), dual-core processor, 1600 MHz, 3 MB L3 Cache, 4 threads, 35W
681954-002	i7-3520M, 2.90GHz (Turbo up to 3.60 GHz), dual-core processor, 1600 MHz, 4MB L3 Cache, 4 threads, 35W
683801-001	500 GB, 7200 rpm , Self Encrypting hard drive (SED)
684793-001	ExpressCard/54 slot
684794-001	Plastics kit
690621-001	Display bezel for use on computer models with a webcam
690622-001	Display bezel for use on computer models without a webcam
690623-001	Cable kit
690624-001	LCD cable kit
690626-001	39.6 cm (15.6 in) FHD AG RGB LED UWVA Dream Color with webcam
690627-001	39.6 cm (15.6 in) FHD AG RGB LED UWVA Dream Color

Spare part number	Description
690628-001	Fan and heat sink assembly for use in computers with AMD FirePro M4000 graphics cards
690629-001	Fan and heat sink assembly for use in computers with NVIDIA Quadro K1000M graphics cards
690630-001	Fan and heat sink assembly for use in computers with NVIDIA Quadro K2000M graphics cards
690631-001	Integrated fingerprint reader
690632-001	Raw Panel Support Kit
690633-001	Battery Latch Kit
690634-001	Power button board
690635-001	Function button board
690636-001	Audio/USB 3.0 board
690637-001	NVIDIA Quadro K2000M (NVIDIA N14P-Q3 2GB DDR3) graphics card
690638-001	NVIDIA Quadro K1000M (NVIDIA N14P-Q1 2GB DDR3) graphics card
690639-001	AMD FirePro M4000 (Chelsea XT GL 1GB GDDR5) graphics card
690640-001	VGA (Dsub 15-pin) port
690641-001	I/O board
690642-001	System board (includes replacement thermal material and VGA support bracket) for use with dual-core processors and the Windows 7 operating system in all countries except China and Russia
690642-501	System board (includes replacement thermal material and VGA support bracket) for use with dual-core processors and the Windows 8 Standard operating system in all countries except China and Russia
690642-601	System board (includes replacement thermal material and VGA support bracket) for use with dual-core processors and the Windows 8 Professional operating system in all countries except China and Russia
690643-001	System board (includes replacement thermal material and VGA support bracket) for use with quad-core processors and the Windows 7 operating system in all countries except China and Russia
690643-501	System board (includes replacement thermal material and VGA support bracket) for use with quad-core processors and the Windows 8 Standard operating system in all countries except China and Russia
690643-601	System board (includes replacement thermal material and VGA support bracket) for use with quad-core processors and the Windows 8 Professional operating system in all countries except China and Russia
690644-001	39.6 cm (15.6 in) High-Definition Plus (HD+) AntiGlare (AG) LED WVA
690645-001	Top cover (includes TouchPad button and bracket)
690647-001	Full-size backlit keyboard with separate numeric keypad and TouchPad scroll zone for use only on computer models equipped with the Windows 7 operating system in the United States
690647-031	Full-size backlit keyboard with separate numeric keypad and TouchPad scroll zone for use only on computer models equipped with the Windows 7 operating system in the United Kingdom and Singapore
690647-041	Full-size backlit keyboard with separate numeric keypad and TouchPad scroll zone for use only on computer models equipped with the Windows 7 operating system in Germany
690647-051	Full-size backlit keyboard with separate numeric keypad and TouchPad scroll zone for use only on computer models equipped with the Windows 7 operating system in France

Spare part number	Description
690647-061	Full-size backlit keyboard with separate numeric keypad and TouchPad scroll zone for use only on computer models equipped with the Windows 7 operating system in Italy
690647-081	Full-size backlit keyboard with separate numeric keypad and TouchPad scroll zone for use only on computer models equipped with the Windows 7 operating system in Denmark
690647-091	Full-size backlit keyboard with separate numeric keypad and TouchPad scroll zone for use only on computer models equipped with the Windows 7 operating system in Norway
690647-161	Full-size backlit keyboard with separate numeric keypad and TouchPad scroll zone for use only on computer models equipped with the Windows 7 operating system in Latin America
690647-251	Full-size backlit keyboard with separate numeric keypad and TouchPad scroll zone for use only on computer models equipped with the Windows 7 operating system in Russia
690647-281	Full-size backlit keyboard with separate numeric keypad and TouchPad scroll zone for use only on computer models equipped with the Windows 7 operating system in Thailand
690647-A41	Full-size backlit keyboard with separate numeric keypad and TouchPad scroll zone for use only on computer models equipped with the Windows 7 operating system in Belgium
690647-AB1	Full-size backlit keyboard with separate numeric keypad and TouchPad scroll zone for use only on computer models equipped with the Windows 7 operating system in Taiwan
690647-AD1	Full-size backlit keyboard with separate numeric keypad and TouchPad scroll zone for use only on computer models equipped with the Windows 7 operating system in South Korea
690647-B31	Full-size backlit keyboard with separate numeric keypad and TouchPad scroll zone for use only on computer models equipped with the Windows 7 operating system in the Netherlands
690647-B71	Full-size backlit keyboard with separate numeric keypad and TouchPad scroll zone for use in only on computer models equipped with the Windows 7 operating system Sweden and Finland
690647-BG1	Full-size backlit keyboard with separate numeric keypad and TouchPad scroll zone for use only on computer models equipped with the Windows 7 operating system in Switzerland
690647-D61	Full-size backlit keyboard with separate numeric keypad and TouchPad scroll zone for use only on computer models equipped with the Windows 7 operating system in India
690647-DB1	Full-size backlit keyboard with separate numeric keypad and TouchPad scroll zone for use only on computer models equipped with the Windows 7 operating system in Canada
690647-FL1	Full-size backlit keyboard with separate numeric keypad and TouchPad scroll zone for use only on computer models equipped with the Windows 7 operating system in the Czech Republic and Slovakia
690648-001	Full-size keyboard with separate numeric keypad and TouchPad scroll zone for use in only on computer models equipped with the Windows 7 operating system the United States
690648-031	Full-size keyboard with separate numeric keypad and TouchPad scroll zone for use in the only on computer models equipped with the Windows 7 operating system United Kingdom and Singapore
690648-041	Full-size keyboard with separate numeric keypad and TouchPad scroll zone for use only on computer models equipped with the Windows 7 operating system in Germany
690648-051	Full-size keyboard with separate numeric keypad and TouchPad scroll zone for use only on computer models equipped with the Windows 7 operating system in France
690648-061	Full-size keyboard with separate numeric keypad and TouchPad scroll zone for use only on computer models equipped with the Windows 7 operating system in Italy

Spare part number	Description
690648-071	Full-size keyboard with separate numeric keypad and TouchPad scroll zone for use only on computer models equipped with the Windows 7 operating system in Spain
690648-081	Full-size keyboard with separate numeric keypad and TouchPad scroll zone for use only on computer models equipped with the Windows 7 operating system in Denmark
690648-091	Full-size keyboard with separate numeric keypad and TouchPad scroll zone for use only on computer models equipped with the Windows 7 operating system in Norway
690648-131	Full-size keyboard with separate numeric keypad and TouchPad scroll zone for use only on computer models equipped with the Windows 7 operating system in Portugal
690648-141	Full-size keyboard with separate numeric keypad and TouchPad scroll zone for use only on computer models equipped with the Windows 7 operating system in Turkey
690648-151	Full-size keyboard with separate numeric keypad and TouchPad scroll zone for use only on computer models equipped with the Windows 7 operating system in Greece
690648-161	Full-size keyboard with separate numeric keypad and TouchPad scroll zone for use only on computer models equipped with the Windows 7 operating system in Latin America
690648-171	Full-size keyboard with separate numeric keypad and TouchPad scroll zone for use only on computer models equipped with the Windows 7 operating system in Saudi Arabia
690648-201	Full-size keyboard with separate numeric keypad and TouchPad scroll zone for use only on computer models equipped with the Windows 7 operating system in Brazil
690648-211	Full-size keyboard with separate numeric keypad and TouchPad scroll zone for use only on computer models equipped with the Windows 7 operating system in Hungary
690648-251	Full-size keyboard with separate numeric keypad and TouchPad scroll zone for use only on computer models equipped with the Windows 7 operating system in Russia
690648-261	Full-size keyboard with separate numeric keypad and TouchPad scroll zone for use only on computer models equipped with the Windows 7 operating system in Bulgaria
690648-271	Full-size keyboard with separate numeric keypad and TouchPad scroll zone for use only on computer models equipped with the Windows 7 operating system in Romania
690648-281	Full-size keyboard with separate numeric keypad and TouchPad scroll zone for use only on computer models equipped with the Windows 7 operating system in Thailand
690648-291	Full-size keyboard with separate numeric keypad and TouchPad scroll zone for use only on computer models equipped with the Windows 7 operating system in Japan
690648-A41	Full-size keyboard with separate numeric keypad and TouchPad scroll zone for use only on computer models equipped with the Windows 7 operating system in Belgium
690648-AB1	Full-size keyboard with separate numeric keypad and TouchPad scroll zone for use only on computer models equipped with the Windows 7 operating system in Taiwan
690648-AD1	Full-size keyboard with separate numeric keypad and TouchPad scroll zone for use only on computer models equipped with the Windows 7 operating system in South Korea
690648-B31	Full-size keyboard with separate numeric keypad and TouchPad scroll zone for use only on computer models equipped with the Windows 7 operating system in the Netherlands
690648-B71	Full-size keyboard with separate numeric keypad and TouchPad scroll zone for use only on computer models equipped with the Windows 7 operating system in Sweden and Finland

Spare part number	Description
690648-BA1	Full-size keyboard with separate numeric keypad and TouchPad scroll zone for use only on computer models equipped with the Windows 7 operating system in Slovenia
690648-BB1	Full-size keyboard with separate numeric keypad and TouchPad scroll zone for use only on computer models equipped with the Windows 7 operating system in Israel
690648-BG1	Full-size keyboard with separate numeric keypad and TouchPad scroll zone for use only on computer models equipped with the Windows 7 operating system in Switzerland
690648-D61	Full-size keyboard with separate numeric keypad and TouchPad scroll zone for use only on computer models equipped with the Windows 7 operating system in India
690648-DB1	Full-size keyboard with separate numeric keypad and TouchPad scroll zone for use only on computer models equipped with the Windows 7 operating system in Canada
690648-DD1	Full-size keyboard with separate numeric keypad and TouchPad scroll zone for use only on computer models equipped with the Windows 7 operating system in Iceland
690648-FL1	Full-size keyboard with separate numeric keypad and TouchPad scroll zone for use only on computer models equipped with the Windows 7 operating system in the Czech Republic and Slovakia
690648-FP1	Full-size keyboard with separate numeric keypad and TouchPad scroll zone for use only on computer models equipped with the Windows 7 operating system in Northwest Africa
693707-001	150W SLIM Smart AC Adapter
693708-001	200W SLIM Smart AC Adapter
693709-001	120W SLIM Smart AC Adapter
694681-001	39.6 cm (15.6 in) FHD AG LED WVA
694682-001	24 GB flash cache
694683-001	6.35 cm (2.5 in) SATA III solid-state 256 GB Self Encrypting Drive
694684-001	6.35 cm (2.5 in) SATA III solid-state 180 GB drive
694685-001	6.35 cm (2.5 in) SATA III solid-state 160 GB drive
694686-001	6.35 cm (2.5 in) SATA III solid-state 128 GB drive
694687-001	12.7 mm tray load DVD-ROM Drive
694688-001	12.7 mm tray load DVD±RW and CD-RW SuperMulti Double Layer (DL) Drive
694689-001	12.7 mm tray load Blu-ray Disc ROM DVD±RW SuperMulti DL Combo Drive
694690-001	12.7 mm tray load Blu-ray Disc R/RE DVD±RW SuperMulti DL Drive
695915-001	Intel Centrino Advanced-N 6205 Combo Adapter
696440-001	System board (includes replacement thermal material and VGA support bracket) for use with dual-core processors in China and Russia only
696441-001	System board (includes replacement thermal material and VGA support bracket) for use with quad-core processors in China and Russia only
698588-001	Intel Centrino Ultimate-N 6300 Combo Adapter
698946-001	Base Enclosure

Spare part number	Description
699687-001	Webcam module
702080-001	HP un2430 EV-DO/HSPA Mini Card
702081-002	Intel Quad Core i7-3630QM 2.40-GHz processor (SC turbo up to 3.40-GHz; 1600-MHz FSB, 6.0-MB L3 cache, 45 W; includes replacement thermal material)
702840-002	Intel Quad Core i7-3740QM 2.70-GHz processor (SC turbo up to 3.70-GHz; 1600-MHz FSB, 6.0-MB L3 cache, 45 W; includes replacement thermal material)
703149-001	Keyboard with backlight, numeric keypad, and pointing stick for use only on computer models equipped with the Windows 8 operating system in the United States (includes backlight cable, keyboard cable, and pointing stick cable)
703149-031	Keyboard with backlight, numeric keypad, and pointing stick for use only on computer models equipped with the Windows 8 operating system in the United Kingdom and Singapore (includes backlight cable, keyboard cable, and pointing stick cable)
703149-041	Keyboard with backlight, numeric keypad, and pointing stick for use only on computer models equipped with the Windows 8 operating system in Germany (includes backlight cable, keyboard cable, and pointing stick cable)
703149-051	Keyboard with backlight, numeric keypad, and pointing stick for use only on computer models equipped with the Windows 8 operating system in France (includes backlight cable, keyboard cable, and pointing stick cable)
703149-061	Keyboard with backlight, numeric keypad, and pointing stick for use only on computer models equipped with the Windows 8 operating system in Italy (includes backlight cable, keyboard cable, and pointing stick cable)
703149-081	Keyboard with backlight, numeric keypad, and pointing stick for use only on computer models equipped with the Windows 8 operating system in Denmark (includes backlight cable, keyboard cable, and pointing stick cable)
703149-091	Keyboard with backlight, numeric keypad, and pointing stick for use only on computer models equipped with the Windows 8 operating system in Norway (includes backlight cable, keyboard cable, and pointing stick cable)
703149-161	Keyboard with backlight, numeric keypad, and pointing stick for use only on computer models equipped with the Windows 8 operating system in Latin America (includes backlight cable, keyboard cable, and pointing stick cable)
703149-251	Keyboard with backlight, numeric keypad, and pointing stick for use only on computer models equipped with the Windows 8 operating system in Russia (includes backlight cable, keyboard cable, and pointing stick cable)
703149-281	Keyboard with backlight, numeric keypad, and pointing stick for use only on computer models equipped with the Windows 8 operating system in Thailand (includes backlight cable, keyboard cable, and pointing stick cable)
703149-A41	Keyboard with backlight, numeric keypad, and pointing stick for use only on computer models equipped with the Windows 8 operating system in Belgium (includes backlight cable, keyboard cable, and pointing stick cable)
703149-AB1	Keyboard with backlight, numeric keypad, and pointing stick for use only on computer models equipped with the Windows 8 operating system in Taiwan (includes backlight cable, keyboard cable, and pointing stick cable)

Spare part number	Description
703149-AD1	Keyboard with backlight, numeric keypad, and pointing stick for use only on computer models equipped with the Windows 8 operating system in South Korea (includes backlight cable, keyboard cable, and pointing stick cable)
703149-B31	Keyboard with backlight, numeric keypad, and pointing stick for use only on computer models equipped with the Windows 8 operating system in the Netherlands (includes backlight cable, keyboard cable, and pointing stick cable)
703149-B71	Keyboard with backlight, numeric keypad, and pointing stick for use only on computer models equipped with the Windows 8 operating system in Sweden and Finland (includes backlight cable, keyboard cable, and pointing stick cable)
703149-BG1	Keyboard with backlight, numeric keypad, and pointing stick for use only on computer models equipped with the Windows 8 operating system in Switzerland (includes backlight cable, keyboard cable, and pointing stick cable)
703149-D61	Keyboard with backlight, numeric keypad, and pointing stick for use only on computer models equipped with the Windows 8 operating system in India (includes backlight cable, keyboard cable, and pointing stick cable)
703149-DB1	Keyboard with backlight, numeric keypad, and pointing stick for use only on computer models equipped with the Windows 8 operating system in Canada (includes backlight cable, keyboard cable, and pointing stick cable)
703149-FL1	Keyboard with backlight, numeric keypad, and pointing stick for use only on computer models equipped with the Windows 8 operating system in the Czech Republic and Slovakia (includes backlight cable, keyboard cable and pointing stick cable)
703151-001	Keyboard with numeric keypad and pointing stick for use only on computer models equipped with the Windows 8 operating system in the United States (includes keyboard cable and pointing stick cable)
703151-031	Keyboard with numeric keypad, and pointing stick for use only on computer models equipped with the Windows 8 operating system in the United Kingdom and Singapore (includes keyboard cable and pointing stick cable)
703151-041	Keyboard with numeric keypad and pointing stick for use only on computer models equipped with the Windows 8 operating system in Germany (includes keyboard cable and pointing stick cable)
703151-051	Keyboard with numeric keypad and pointing stick for use only on computer models equipped with the Windows 8 operating system in France (includes keyboard cable and pointing stick cable)
703151-061	Keyboard with numeric keypad and pointing stick for use only on computer models equipped with the Windows 8 operating system in Italy (includes keyboard cable and pointing stick cable)
703151-071	Keyboard with numeric keypad and pointing stick for use only on computer models equipped with the Windows 8 operating system in Spain (includes keyboard cable and pointing stick cable)
703151-081	Keyboard with numeric keypad and pointing stick for use only on computer models equipped with the Windows 8 operating system in Denmark (includes keyboard cable and pointing stick cable)
703151-091	Keyboard with numeric keypad and pointing stick for use only on computer models equipped with the Windows 8 operating system in Norway (includes keyboard cable and pointing stick cable)
703151-131	Keyboard with numeric keypad and pointing stick for use only on computer models equipped with the Windows 8 operating system in Portugal (includes keyboard cable and pointing stick cable)
703151-141	Keyboard with numeric keypad and pointing stick for use only on computer models equipped with the Windows 8 operating system in Turkey (includes keyboard cable and pointing stick cable)
703151-151	Keyboard with numeric keypad and pointing stick for use only on computer models equipped with the Windows 8 operating system in Greece (includes keyboard cable and pointing stick cable)

Spare part number	Description
703151-161	Keyboard with numeric keypad and pointing stick for use only on computer models equipped with the Windows 8 operating system in Latin America (includes keyboard cable and pointing stick cable)
703151-171	Keyboard with numeric keypad and pointing stick for use only on computer models equipped with the Windows 8 operating system in Turkey (includes keyboard cable and pointing stick cable)
703151-201	Keyboard with numeric keypad and pointing stick for use only on computer models equipped with the Windows 8 operating system in Brazil (includes keyboard cable and pointing stick cable)
703151-211	Keyboard with numeric keypad and pointing stick for use only on computer models equipped with the Windows 8 operating system in Hungary (includes keyboard cable and pointing stick cable)
703151-251	Keyboard with numeric keypad and pointing stick for use only on computer models equipped with the Windows 8 operating system in Russia (includes keyboard cable and pointing stick cable)
703151-261	Keyboard with numeric keypad and pointing stick for use only on computer models equipped with the Windows 8 operating system in Bulgaria (includes keyboard cable and pointing stick cable)
703151-271	Keyboard with numeric keypad and pointing stick for use only on computer models equipped with the Windows 8 operating system in Romania (includes keyboard cable and pointing stick cable)
703151-281	Keyboard with numeric keypad and pointing stick for use only on computer models equipped with the Windows 8 operating system in Thailand (includes keyboard cable and pointing stick cable)
703151-291	Keyboard with numeric keypad and pointing stick for use only on computer models equipped with the Windows 8 operating system in Japan (includes keyboard cable and pointing stick cable)
703151-A41	Keyboard with numeric keypad and pointing stick for use only on computer models equipped with the Windows 8 operating system in Belgium (includes keyboard cable and pointing stick cable)
703151-AB1	Keyboard with numeric keypad and pointing stick for use only on computer models equipped with the Windows 8 operating system in Taiwan (includes keyboard cable and pointing stick cable)
703151-AD1	Keyboard with numeric keypad and pointing stick for use only on computer models equipped with the Windows 8 operating system in South Korea (includes keyboard cable and pointing stick cable)
703151-B31	Keyboard with numeric keypad and pointing stick for use only on computer models equipped with the Windows 8 operating system in the Netherlands (includes keyboard cable and pointing stick cable)
703151-B71	Keyboard with numeric keypad and pointing stick for use only on computer models equipped with the Windows 8 operating system in Sweden and Finland (includes keyboard cable and pointing stick cable)
703151-BA1	Keyboard with numeric keypad and pointing stick for use only on computer models equipped with the Windows 8 operating system in Slovenia (includes keyboard cable and pointing stick cable)
703151-BB1	Keyboard with numeric keypad and pointing stick for use only on computer models equipped with the Windows 8 operating system in Israel (includes keyboard cable and pointing stick cable)
703151-BG1	Keyboard with numeric keypad and pointing stick for use only on computer models equipped with the Windows 8 operating system in Switzerland (includes keyboard cable and pointing stick cable)
703151-D61	Keyboard with numeric keypad and pointing stick for use only on computer models equipped with the Windows 8 operating system in India (includes keyboard cable and pointing stick cable)
703151-DB1	Keyboard with numeric keypad and pointing stick for use only on computer models equipped with the Windows 8 operating system in Canada (includes keyboard cable and pointing stick cable)
703151-DD1	Keyboard with numeric keypad and pointing stick for use only on computer models equipped with the Windows 8 operating system in Iceland (includes keyboard cable and pointing stick cable)

Spare part number	Description
703151-FL1	Keyboard with numeric keypad and pointing stick for use only on computer models equipped with the Windows 8 operating system in the Czech Republic and Slovakia (includes keyboard cable and pointing stick cable)
703151-FP1	Keyboard with numeric keypad and pointing stick for use only on computer models equipped with the Windows 8 operating system in Northwest Africa (includes keyboard cable and pointing stick cable)
703266-002	Intel Quad Core i7-3840QM 2.80-GHz processor (SC turbo up to 3.80-GHz; 1600-MHz FSB, 8.0-MB L3 cache, 45 W; includes replacement thermal material)
705053-001	128-GB SATA III solid-state drive
710789-001	HP hs2350 HSPA+ Mobile Broadband Module

4 Removal and replacement procedures

Preliminary replacement requirements

Tools required

You will need the following tools to complete the removal and replacement procedures:

- Flat-bladed screwdriver
- Phillips P0 and P1 screwdrivers
- Torx 8 screwdriver

Service considerations

The following sections include some of the considerations that you must keep in mind during disassembly and assembly procedures.



NOTE: As you remove each subassembly from the computer, place the subassembly (and all accompanying screws) away from the work area to prevent damage.

Plastic parts



CAUTION: Using excessive force during disassembly and reassembly can damage plastic parts. Use care when handling the plastic parts. Apply pressure only at the points designated in the maintenance instructions.

Cables and connectors

⚠ CAUTION: When servicing the computer, be sure that cables are placed in their proper locations during the reassembly process. Improper cable placement can damage the computer.

Cables must be handled with extreme care to avoid damage. Apply only the tension required to unseat or seat the cables during removal and insertion. Handle cables by the connector whenever possible. In all cases, avoid bending, twisting, or tearing cables. Be sure that cables are routed in such a way that they cannot be caught or snagged by parts being removed or replaced. Handle flex cables with extreme care; these cables tear easily.

Drive handling

⚠ CAUTION: Drives are fragile components that must be handled with care. To prevent damage to the computer, damage to a drive, or loss of information, observe these precautions:

Before removing or inserting a hard drive, shut down the computer. If you are unsure whether the computer is off or in Hibernation, turn the computer on, and then shut it down through the operating system.

Before handling a drive, be sure that you are discharged of static electricity. While handling a drive, avoid touching the connector.

Before removing a diskette drive or optical drive, be sure that a diskette or disc is not in the drive and be sure that the optical drive tray is closed.

Handle drives on surfaces covered with at least 2.5 cm (one inch) of shock-proof foam.

Avoid dropping drives from any height onto any surface.

After removing a hard drive, an optical drive, or a diskette drive, place it in a static-proof bag.

Avoid exposing a hard drive to products that have magnetic fields, such as monitors or speakers.

Avoid exposing a drive to temperature extremes or liquids.

If a drive must be mailed, place the drive in a bubble pack mailer or other suitable form of protective packaging and label the package "FRAGILE."

Grounding guidelines

Electrostatic discharge damage

Electronic components are sensitive to electrostatic discharge (ESD). Circuitry design and structure determine the degree of sensitivity. Networks built into many integrated circuits provide some protection, but in many cases, ESD contains enough power to alter device parameters or melt silicon junctions.

A discharge of static electricity from a finger or other conductor can destroy static-sensitive devices or microcircuitry. Even if the spark is neither felt nor heard, damage may have occurred.

An electronic device exposed to ESD may not be affected at all and can work perfectly throughout a normal cycle. Or the device may function normally for a while, and then degrade in the internal layers, reducing its life expectancy.

⚠ CAUTION: To prevent damage to the computer when you are removing or installing internal components, observe these precautions:

Keep components in their electrostatic-safe containers until you are ready to install them.

Use nonmagnetic tools.

Before touching an electronic component, discharge static electricity by using the guidelines described in this section.

Avoid touching pins, leads, and circuitry. Handle electronic components as little as possible.

If you remove a component, place it in an electrostatic-safe container.

The following table shows how humidity affects the electrostatic voltage levels generated by different activities.

⚠ CAUTION: A product can be degraded by as little as 700 V.

Typical electrostatic voltage levels			
Event	Relative humidity		
	10%	40%	55%
Walking across carpet	35,000 V	15,000 V	7,500 V
Walking across vinyl floor	12,000 V	5,000 V	3,000 V
Motions of bench worker	6,000 V	800 V	400 V
Removing DIPS from plastic tube	2,000 V	700 V	400 V
Removing DIPS from vinyl tray	11,500 V	4,000 V	2,000 V
Removing DIPS from Styrofoam	14,500 V	5,000 V	3,500 V
Removing bubble pack from PCB	26,500 V	20,000 V	7,000 V
Packing PCBs in foam-lined box	21,000 V	11,000 V	5,000 V

Packaging and transporting guidelines

Follow these grounding guidelines when packaging and transporting equipment:

- To avoid hand contact, transport products in static-safe tubes, bags, or boxes.
- Protect ESD-sensitive parts and assemblies with conductive or approved containers or packaging.
- Keep ESD-sensitive parts in their containers until the parts arrive at static-free workstations.
- Place items on a grounded surface before removing items from their containers.
- Always be properly grounded when touching a component or assembly.
- Store reusable ESD-sensitive parts from assemblies in protective packaging or nonconductive foam.
- Use transporters and conveyors made of antistatic belts and roller bushings. Be sure that mechanized equipment used for moving materials is wired to ground and that proper materials are selected to avoid static charging. When grounding is not possible, use an ionizer to dissipate electric charges.

Workstation guidelines

Follow these grounding workstation guidelines:

- Cover the workstation with approved static-shielding material.
- Use a wrist strap connected to a properly grounded work surface and use properly grounded tools and equipment.
- Use conductive field service tools, such as cutters, screwdrivers, and vacuums.
- When fixtures must directly contact dissipative surfaces, use fixtures made only of static-safe materials.
- Keep the work area free of nonconductive materials, such as ordinary plastic assembly aids and Styrofoam.
- Handle ESD-sensitive components, parts, and assemblies by the case or PCM laminate. Handle these items only at static-free workstations.
- Avoid contact with pins, leads, or circuitry.
- Turn off power and input signals before inserting or removing connectors or test equipment.

Equipment guidelines

Grounding equipment must include either a wrist strap or a foot strap at a grounded workstation.

- When seated, wear a wrist strap connected to a grounded system. Wrist straps are flexible straps with a minimum of one megohm $\pm 10\%$ resistance in the ground cords. To provide proper ground, wear a strap snugly against the skin at all times. On grounded mats with banana-plug connectors, use alligator clips to connect a wrist strap.
- When standing, use foot straps and a grounded floor mat. Foot straps (heel, toe, or boot straps) can be used at standing workstations and are compatible with most types of shoes or boots. On conductive floors or dissipative floor mats, use foot straps on both feet with a minimum of one megohm resistance between the operator and ground. To be effective, the conductive strips must be worn in contact with the skin.

The following grounding equipment is recommended to prevent electrostatic damage:

- Antistatic tape
- Antistatic smocks, aprons, and sleeve protectors
- Conductive bins and other assembly or soldering aids
- Nonconductive foam
- Conductive tabletop workstations with ground cords of one megohm resistance
- Static-dissipative tables or floor mats with hard ties to the ground
- Field service kits
- Static awareness labels
- Material-handling packages
- Nonconductive plastic bags, tubes, or boxes
- Metal tote boxes
- Electrostatic voltage levels and protective materials

The following table lists the shielding protection provided by antistatic bags and floor mats.

Material	Use	Voltage protection level
Antistatic plastic	Bags	1,500 V
Carbon-loaded plastic	Floor mats	7,500 V
Metallized laminate	Floor mats	5,000 V

Component replacement procedures

This chapter provides removal and replacement procedures.

 **IMPORTANT:** There are as many as 95 screws and screw locks, in 15 different sizes, that must be removed, replaced, or loosened when servicing the computer. Make special note of each screw and screw lock size and location during removal and replacement.

Service tag

When ordering parts or requesting information, provide the computer serial number and model description provided on the service tag.

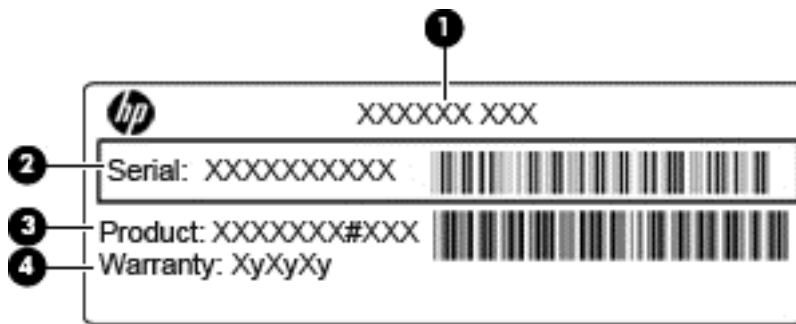

Item	Description	Function
(1)	Product name	The name affixed to the front of the computer.
(2)	Serial number (s/n)	This is an alphanumeric identifier that is unique to each product.
(3)	Part number/Product number (p/n)	This number provides specific information about the product's hardware components. The part number helps a service technician to determine what components and parts are needed.
(4)	Warranty period	This number describes the duration of the warranty period for the computer.

Battery

Description	Spare part number
8-cell, 83-Wh Li-ion battery	632427-001
8-cell, 75-Wh Li-ion battery	632425-001
9-cell, 73-Wh Li-ion extended life battery	634089-001
9-cell, 100-Wh Li-ion ultra-capacity extended life battery	634087-001

Before disassembling the computer, follow these steps:

1. Shut down the computer. If you are unsure whether the computer is off or in Hibernation, turn the computer on, and then shut it down through the operating system.
2. Disconnect all external devices connected to the computer.
3. Disconnect the power from the computer by first unplugging the power cord from the AC outlet, and then unplugging the AC adapter from the computer.

Remove the battery:

1. Turn the computer upside down on a flat surface, with the battery bay toward you.
2. Slide the battery release latch **(1)** to release the battery.
3. Rotate the battery **(2)** forward, and then remove it from the computer **(3)** from the computer.

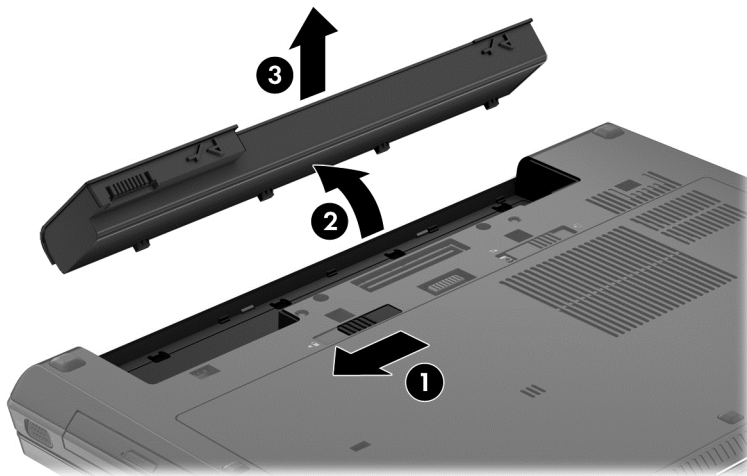

Install the battery by inserting it into the battery bay until you hear a click.

Display panel (non-DreamColor)

Description	Spare part number
HD+ WVA display panel	690644-001
FHD WVA display panel	694681-001

 **NOTE:** The display panel can be removed separately from the display assembly only on non-Dream Color Models. .

Before removing the display panel, follow these steps:

 **IMPORTANT:** Make special note of each screw and screw lock size and location during removal and replacement.

1. Shut down the computer. If you are unsure whether the computer is off or in Hibernation, turn the computer on, and then shut it down through the operating system.
2. Disconnect all external devices connected to the computer.
3. Disconnect the power from the computer by first unplugging the power cord from the AC outlet and then unplugging the AC adapter from the computer.
4. Remove the battery (see [Battery on page 54](#)).

Remove the display panel:

1. Remove the display bezel:
 - a. Position the computer upright on a flat surface with the display panel open.
 - b. Remove the two rubber pads **(1)** that cover the display panel screws.

- c. Remove the two Torx 8 screws **(2)** that secure the display bezel to the display enclosure.

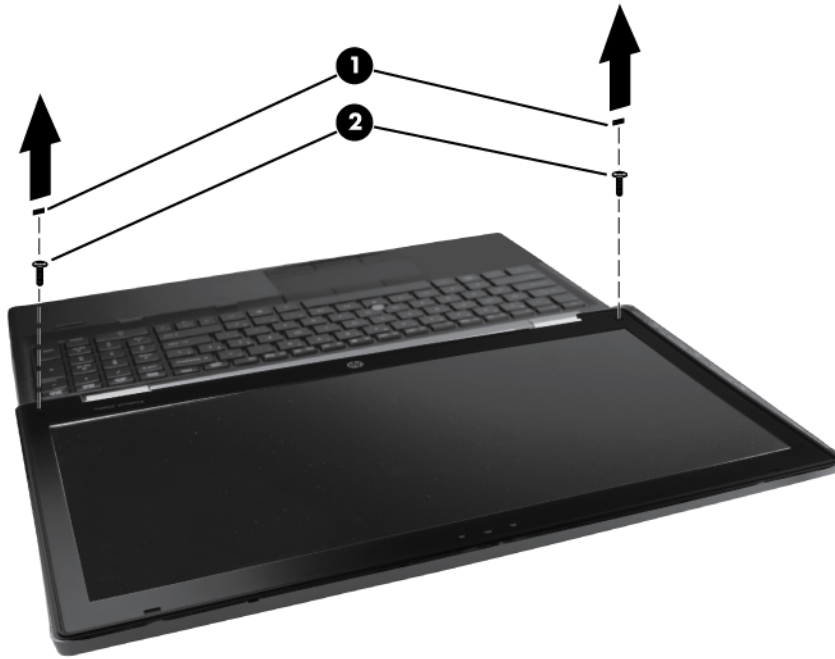

- d. Flex the top **(1)** of the bezel from the inside edge until it disengages from the display back cover.
- e. Flex the inside edge of the left side and the right side **(2)** of the bezel until it disengages from the display back cover.
- f. Flex the bottom **(3)** of the bezel from the inside edge until it disengages from the display back cover.
- g. Remove the display bezel from the display back cover **(4)**.

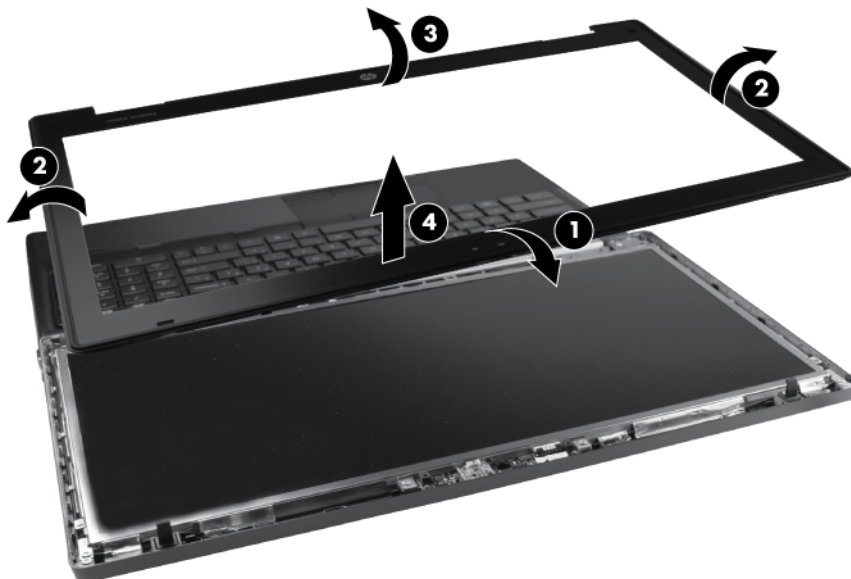

2. Remove the six Torx 8 screws **(1)** that secure the display panel to the display enclosure **(2)**.



3. Disengage the display panel from the base enclosure by closing the display enclosure to 45 degrees while holding the sides of the display panel.

4. Remove the two pieces of tape **(1)** and **(2)** that secure cables to the back of the display panel. Carefully disconnect the cable from the connector.

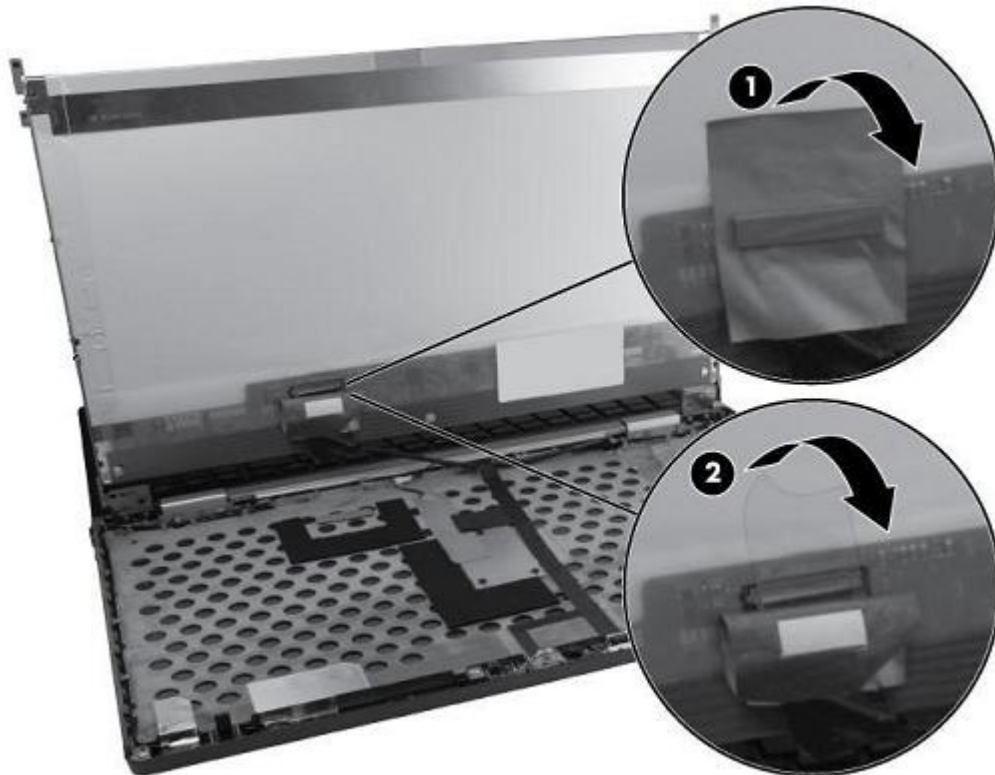

5. Remove the eight Phillips screws **(1)** that secure the display panel to the display hinges (four on either side).
6. Remove the display panel **(2)**.



Reverse this procedure to install the display panel.

SIM

 **NOTE:** If there is a SIM inserted in the SIM slot, it must be removed before disassembling the computer. Be sure that the SIM is reinserted in the SIM slot after reassembling the computer.

Before removing the SIM, follow these steps:

1. Shut down the computer. If you are unsure whether the computer is off or in Hibernation, turn the computer on, and then shut it down through the operating system.
2. Disconnect all external devices connected to the computer.
3. Disconnect the power from the computer by first unplugging the power cord from the AC outlet, and then unplugging the AC adapter from the computer.
4. Remove the battery (see [Battery on page 54](#)).

Remove the SIM:

1. Inside the battery bay, press in on the SIM **(1)**. (The module is partially ejected from the SIM slot.)
2. Remove the SIM **(2)** from the SIM slot.

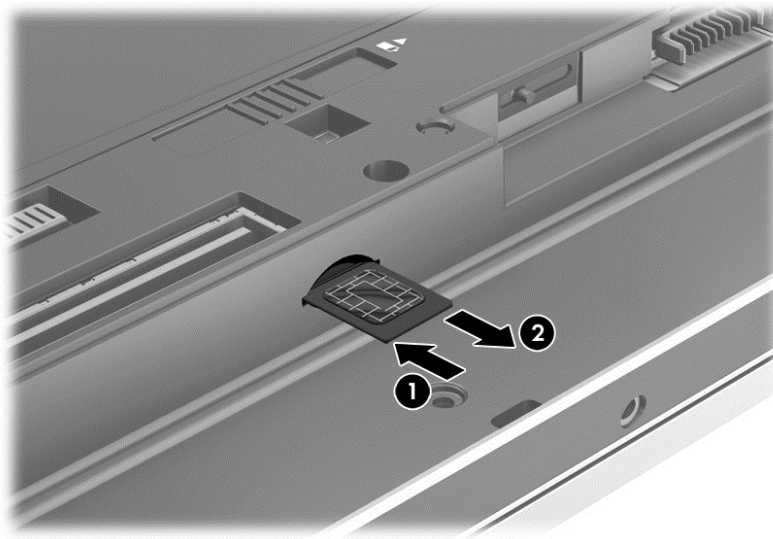

Reverse this procedure to install the SIM.

Service door

Description	Spare part number
Service door	652648-001

Before removing the service door, follow these steps:

1. Shut down the computer. If you are unsure whether the computer is off or in Hibernation, turn the computer on, and then shut it down through the operating system.
2. Disconnect all external devices connected to the computer.
3. Disconnect the power from the computer by first unplugging the power cord from the AC outlet and then unplugging the AC adapter from the computer.
4. Remove the battery (see [Battery on page 54](#)).

Remove the service door:

1. Position the computer upside down, with the back of the computer toward you.
2. Slide the service door release latch to the left **(1)**, revealing the service door securing screw (if present). Remove this screw **(2)**.



NOTE: There is a threaded receptacle on the inside of the service door for stowing this screw.

3. While sliding the service door release latch fully to the left **(3)**, slide the service door away from you **(4)**.

4. Remove the service door (5).

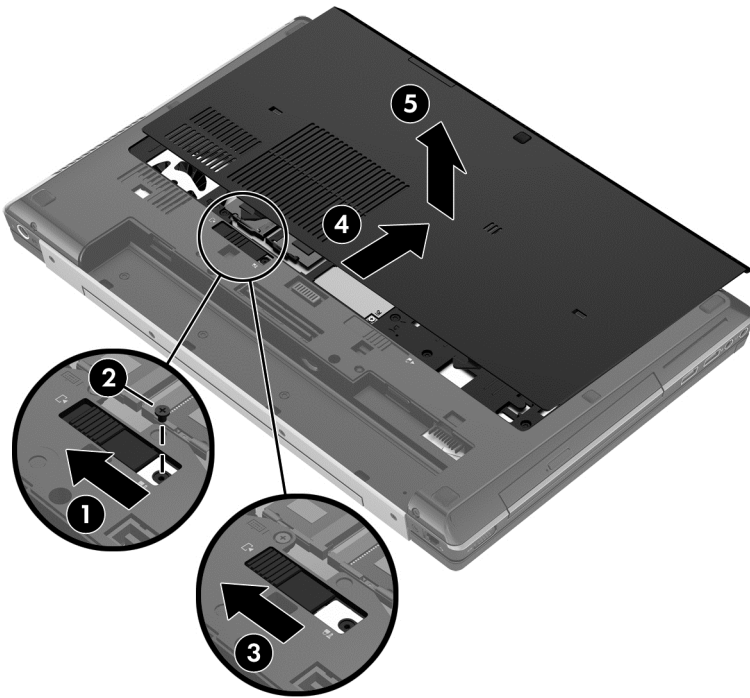

Memory Modules (under service door)



NOTE: A computer having a system board with spare part number 690643-001 or 696441-001 has four memory slots. In this case, the primary memory is located under the keyboard and expansion memory is located under the service door.

A computer having a system board with spare part number 690642-001 or 696440-001 has two memory module slots. In this case, the primary memory is located under the service door.

To access memory modules under the keyboard, see [Memory Modules \(under keyboard\) on page 85](#).

Description	Spare part number
8 GB (DDR3 1600MHz PC3-12800)	670034-001
4 GB (DDR3 1600MHz PC3-12800)	641369-001
2 GB (DDR3 1600MHz PC3-12800)	652972-001

Before removing a memory module, follow these steps:

1. Shut down the computer. If you are unsure whether the computer is off or in Hibernation, turn the computer on, and then shut it down through the operating system.
2. Disconnect all external devices connected to the computer.
3. Disconnect the power from the computer by first unplugging the power cord from the AC outlet, and then unplugging the AC adapter from the computer.
4. Remove the battery (see [Battery on page 54](#)).
5. Remove the service door (see [Service door on page 60](#)).

Remove the memory module:

1. Position the computer upside down, with the front toward you.
2. Spread the retaining tabs **(1)** on each side of the memory module slot to release the memory module. (The edge of the module opposite the slot rises away from the computer.)

3. Remove the memory module **(2)** by pulling the module away from the slot at an angle.

 **NOTE:** Memory modules are designed with a notch to prevent incorrect insertion into the memory module slot.

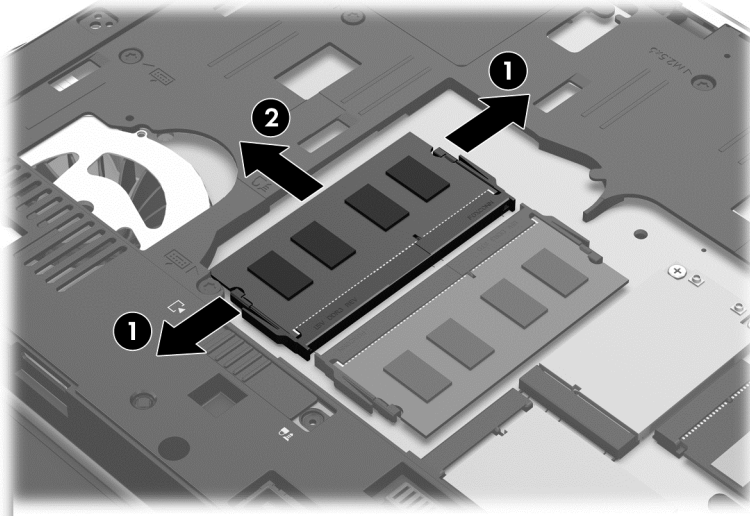

Reverse this procedure to install a memory module.

RTC battery

Description	Spare part number
RTC battery	652650-001

Before removing the RTC battery, follow these steps:

1. Shut down the computer. If you are unsure whether the computer is off or in Hibernation, turn the computer on, and then shut it down through the operating system.
2. Disconnect all external devices connected to the computer.
3. Disconnect the power from the computer by first unplugging the power cord from the AC outlet, and then unplugging the AC adapter from the computer.
4. Remove the battery (see [Battery on page 54](#)).
5. Remove the service door (see [Service door on page 60](#)).

Remove the RTC battery:

1. Position the computer upside down, with the front toward you.
2. Disconnect the RTC battery cable **(1)** from the system board.
3. Gently pull the battery **(2)** from the double-sided tape that secures it to the system board and remove it from the computer.

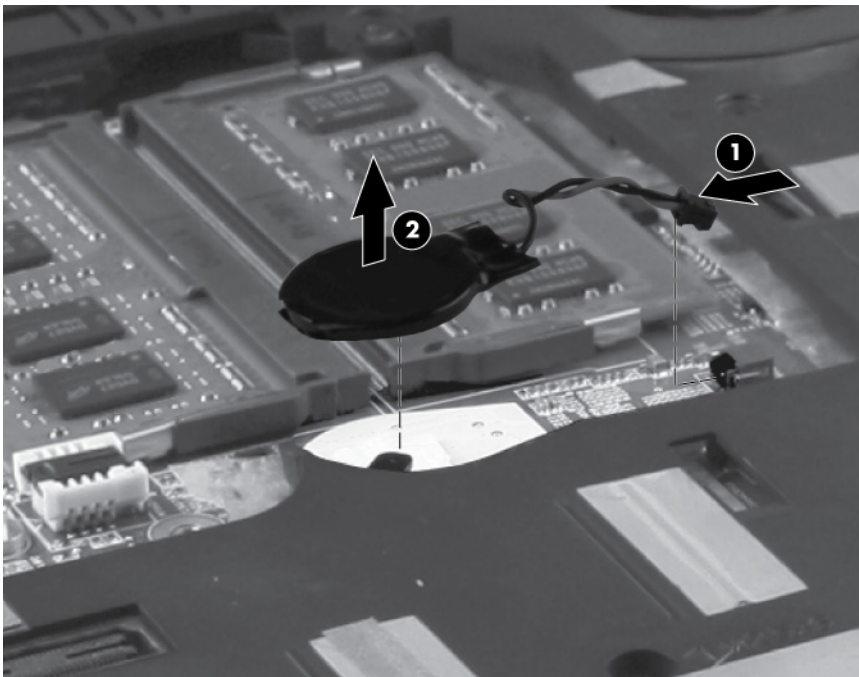

Reverse this procedure to install the RTC battery.

WLAN module

 **CAUTION:** The WLAN module and the WWAN module are not interchangeable.

Description	Spare part number
Broadcom 43228 802.11 a/b/g/n Wi-Fi 2x2 Adapter	669832-001
Intel Centrino Advanced N 6205 802.11 a/b/g/n 2x2 WiFi Adapter	631954-001
Intel Centrino Advanced-N 6205 Combo Adapter	695915-001
Intel Centrino Ultimate-N 6300 802.11 a/b/g/n 3x3 WiFi Adapter	572511-001
Intel Centrino Ultimate-N 6300 Combo Adapter	698588-001

Before removing the WLAN module, follow these steps:

1. Shut down the computer. If you are unsure whether the computer is off or in Hibernation, turn the computer on, and then shut it down through the operating system.
2. Disconnect all external devices connected to the computer.
3. Disconnect the power from the computer by first unplugging the power cord from the AC outlet, and then unplugging the AC adapter from the computer.
4. Remove the battery (see [Battery on page 54](#)).
5. Remove the service door (see [Service door on page 60](#)).

Remove the WLAN module:

 **IMPORTANT:** Make special note of each screw and screw lock size and location during removal and replacement.

1. Position the computer upside down, with the front toward you.

2. Disconnect the WLAN antenna cables (1) from the terminals on the WLAN module.

 **NOTE:** The WLAN antenna cable marked with [1] is connected to the WLAN module “Main” terminal. The WLAN antenna cable marked with [2] is connected to the WLAN module “Aux” terminal. If the computer is equipped with an 802.11 a/b/g/n WLAN module, the WLAN antenna cable marked with [3] is connected to the middle terminal on the WLAN module.

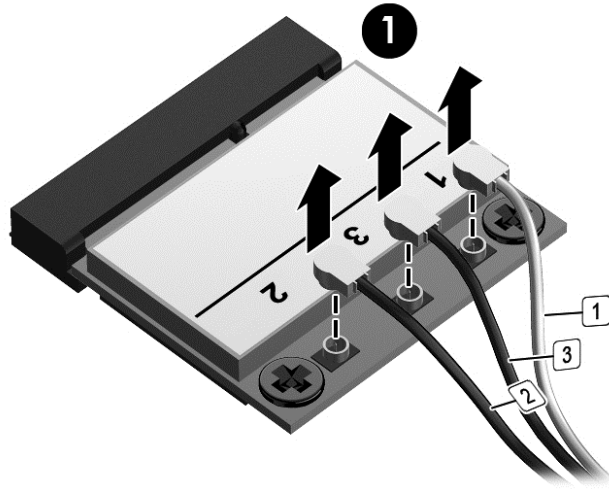

3. Remove the two Phillips screws (2) that secure the WLAN module to the computer. (The edge of the module opposite the slot rises away from the computer.)

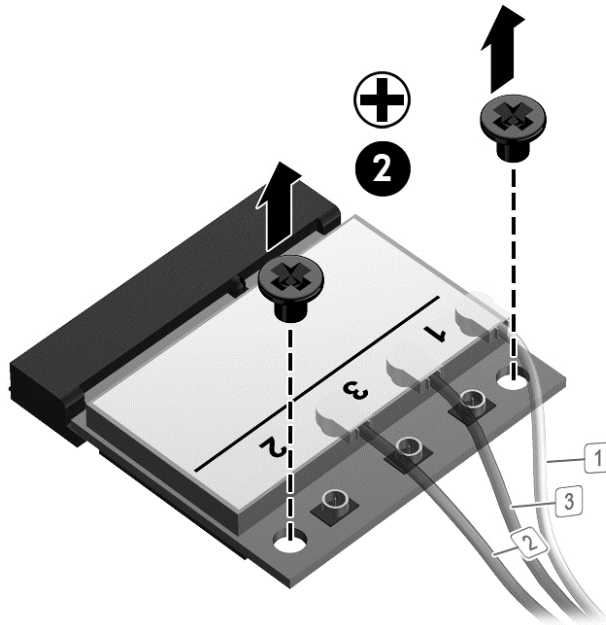

4. Remove the WLAN module **(3)** by pulling the module away from the slot at an angle.

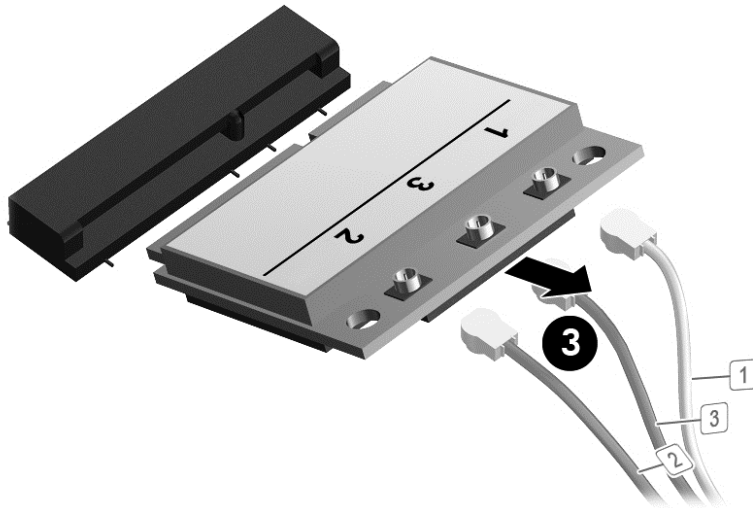

 **NOTE:** WLAN modules are designed with a notch to prevent incorrect insertion.

Reverse this procedure to install the WLAN module.

WWAN module

 **CAUTION:** The WWAN module and the WLAN module are not interchangeable.

Description	Spare part number
HP hs2350 HSPA+ Mobile Broadband Module	668969-001
HP lt2523 LTE/HSPA+ Mobile Broadband Module	675793-001
HP lt2522 LTE/EV-DO Mobile Broadband Module	710789-001
HP un2430 EV-DO/HSPA Mini Card	702080-001
HP un2430 EV-DO/HSPA Mobile Broadband Module	634400-001

Before removing the WWAN module, follow these steps:

1. Shut down the computer. If you are unsure whether the computer is off or in Hibernation, turn the computer on, and then shut it down through the operating system.
2. Disconnect all external devices connected to the computer.
3. Disconnect the power from the computer by first unplugging the power cord from the AC outlet, and then unplugging the AC adapter from the computer.
4. Remove the battery (see [Battery on page 54](#)).
5. Remove the service door (see [Service door on page 60](#)).

Remove the WWAN module:

1. Position the computer right-side up with front toward you.
2. Disconnect the WWAN antenna cables **(1)** and **(2)** from the terminals on the WWAN module.



NOTE: The red WWAN antenna cable is connected to the WWAN module “Main” terminal. The blue WWAN antenna cable is connected to the WWAN module “Aux” terminal.

3. Remove the two Phillips screws **(3)** that secure the WWAN module to the computer. (The edge of the module opposite the slot rises away from the computer.)

4. Remove the WWAN module **(4)** by pulling the module away from the slot at an angle.

 **NOTE:** WWAN modules are designed with a notch **(5)** to prevent incorrect insertion.

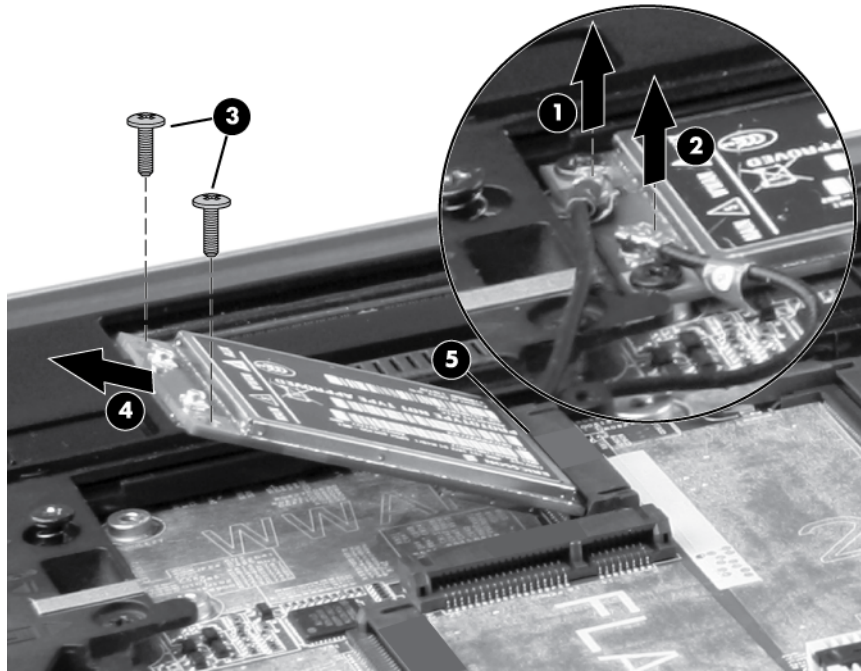

Reverse this procedure to install the WWAN module.

Bluetooth module



NOTE: The Bluetooth module spare part kit does not include a Bluetooth module cable. The Bluetooth module cable is included in the cable kit, spare part number 690624-001. For information about cable kit contents, see [Cable Kit on page 33](#).

Description	Spare part number
Bluetooth module	655792-001

Before removing the Bluetooth module, follow these steps:

1. Shut down the computer. If you are unsure whether the computer is off or in Hibernation, turn the computer on, and then shut it down through the operating system.
2. Disconnect all external devices connected to the computer.
3. Disconnect the power from the computer by first unplugging the power cord from the AC outlet, and then unplugging the AC adapter from the computer.
4. Remove the battery (see [Battery on page 54](#)).
5. Remove the service door (see [Service door on page 60](#)).

Remove the Bluetooth module:

1. Position the computer upside down, with the front toward you.
2. Remove the tape from the top of the Bluetooth module **(1)**.
3. Remove the tape from the Bluetooth cable **(2)**.
4. Disconnect the Bluetooth cable **(3)** from the system board.
5. Disconnect the Bluetooth module cable **(4)** from the Bluetooth module.

6. Remove the Bluetooth module.

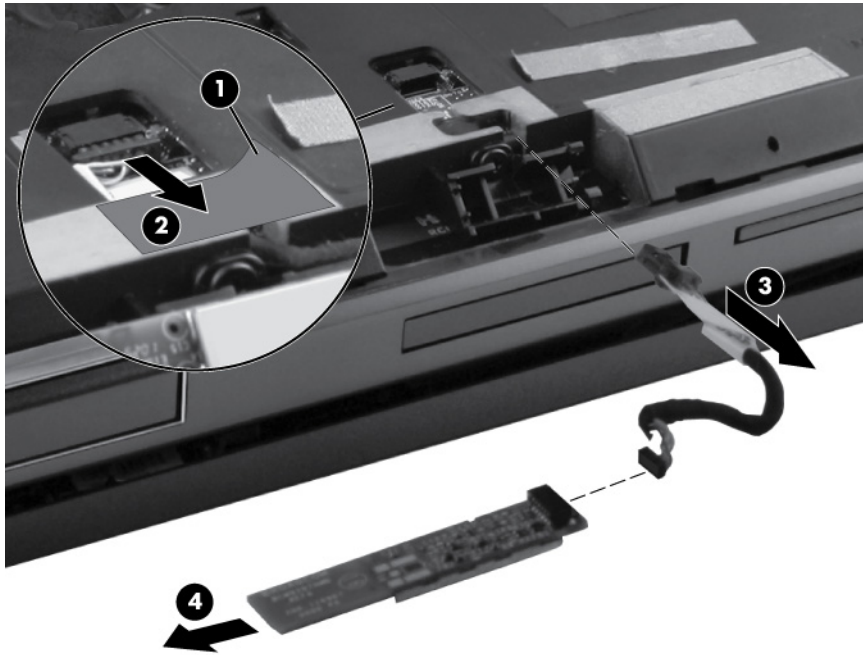

Reverse this procedure to install the Bluetooth module.

Hard drive

Description	Spare part number
750 GB, 7200 rpm hard drive	633252-001
500 GB, 7200 rpm hard drive	634925-001
500 GB, 7200 rpm , SED hard drive	683801-001
320 GB, 7200 rpm hard drive	634862-001
256 GB SATA III SED SSD	694683-001
180 GB SATA II SSD	694684-001
160 GB SATA II SSD	694685-001
128 GB SATA III SSD	653434-001
128 GB SATA III SSD locked	705053-001
Hard Drive Hardware Kit (includes hard drive bracket and screws)	644694-001

Before disassembling the computer, follow these steps:

1. Shut down the computer. If you are unsure whether the computer is off or in Hibernation, turn the computer on, and then shut it down through the operating system.
2. Disconnect all external devices connected to the computer.
3. Disconnect the power from the computer by first unplugging the power cord from the AC outlet, and then unplugging the AC adapter from the computer.
4. Remove the battery (see [Battery on page 54](#)).
5. Remove the service door (see [Service door on page 60](#)).

Remove the hard drive:



IMPORTANT: Make special note of each screw and screw lock size and location during removal and replacement.

1. Position the computer upside down, with the front toward you.
2. Remove the tape from the top of the smart card reader door **(1)**.

3. Loosen the two Phillips captive screws **(2)** that secure the smart card reader door to the computer.

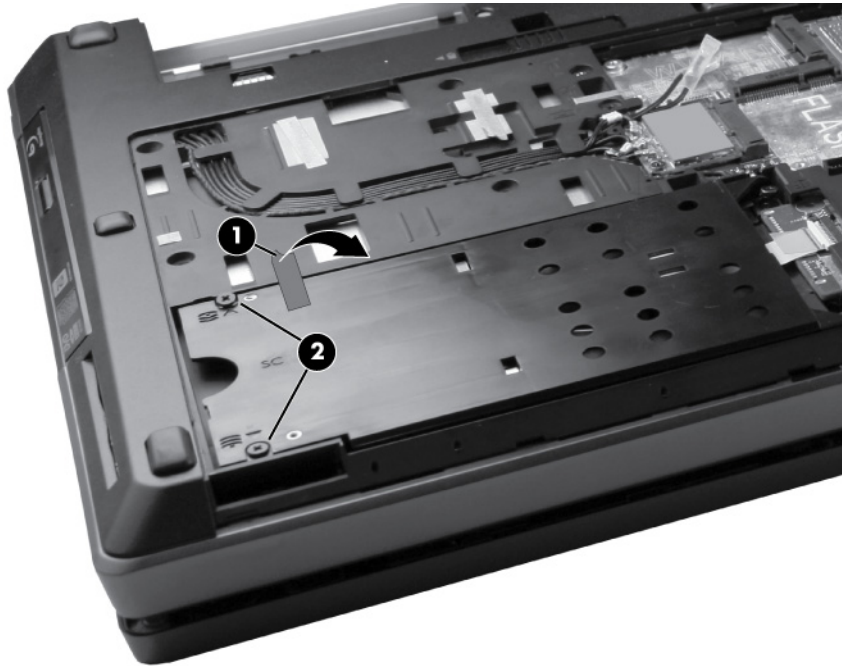

4. Open the smart card reader door until it rests on its hinges **(1)**.
5. Remove three Phillips spring-loaded screws **(2)** that secure the hard drive to the computer.
6. Grasp the tab on the hard drive, pull the hard drive to the left **(3)**, and remove the hard drive **(4)** from the hard drive bay.

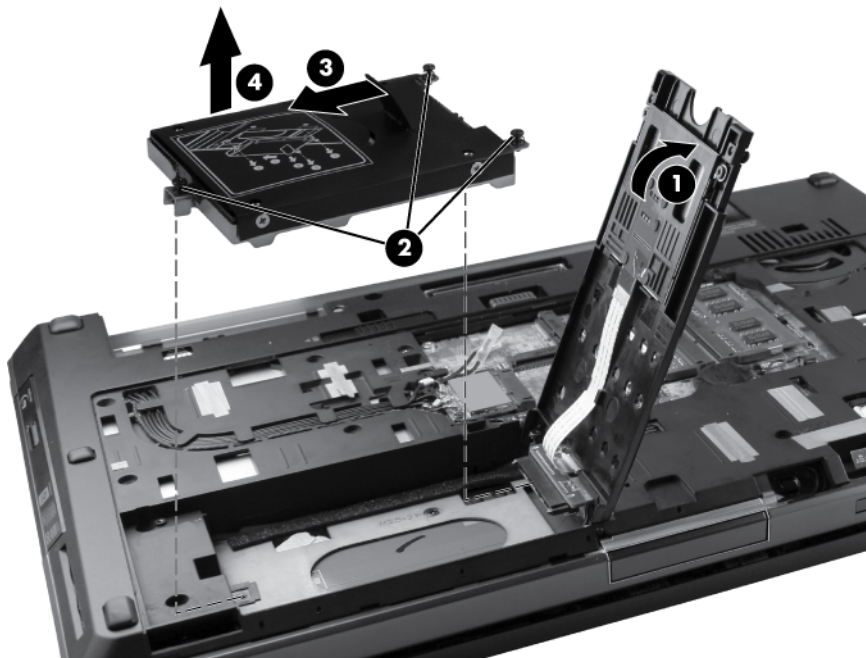

7. If it is necessary to replace the hard drive bracket, remove the four Phillips hard drive bracket screws **(1)** from the sides of the hard drive.

8. Lift the bracket **(2)** straight up to remove it from the hard drive.

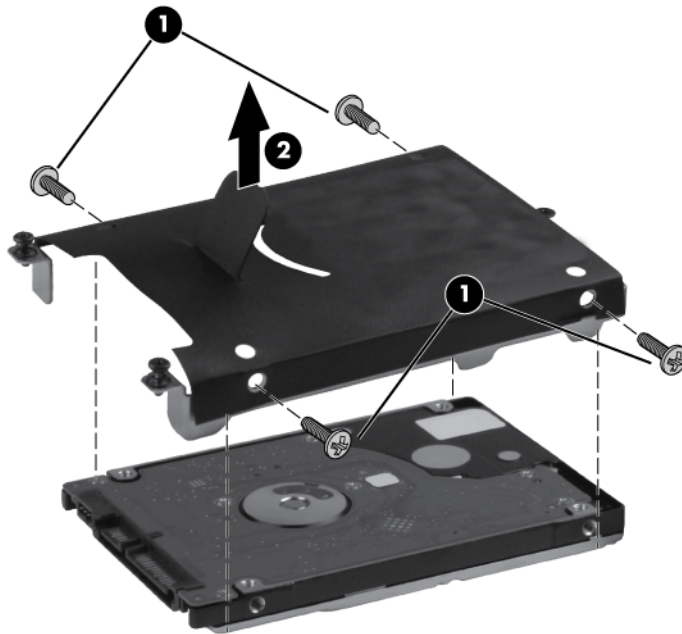

Reverse this procedure to reassemble and install the hard drive.

Smart card reader

Description	Spare part number
Smart card reader (includes door and cable)	652672-001

Before removing the smart card reader, follow these steps:

 **IMPORTANT:** Make special note of each screw and screw lock size and location during removal and replacement.

1. Shut down the computer. If you are unsure whether the computer is off or in Hibernation, turn the computer on, and then shut it down through the operating system.
2. Disconnect all external devices connected to the computer.
3. Disconnect the power from the computer by first unplugging the power cord from the AC outlet, and then unplugging the AC adapter from the computer.
4. Remove the battery (see [Battery on page 54](#)).
5. Remove the service door (see [Service door on page 60](#)).
6. Remove the hard drive (see [Hard drive on page 72](#)).

Remove the smart card reader:

1. If you need to replace the smart card reader door, close the door **(1)**.
2. Open the zero insertion force (ZIF) connector for the smart card reader cable **(2)** and then disconnect the cable from the system board **(3)**.

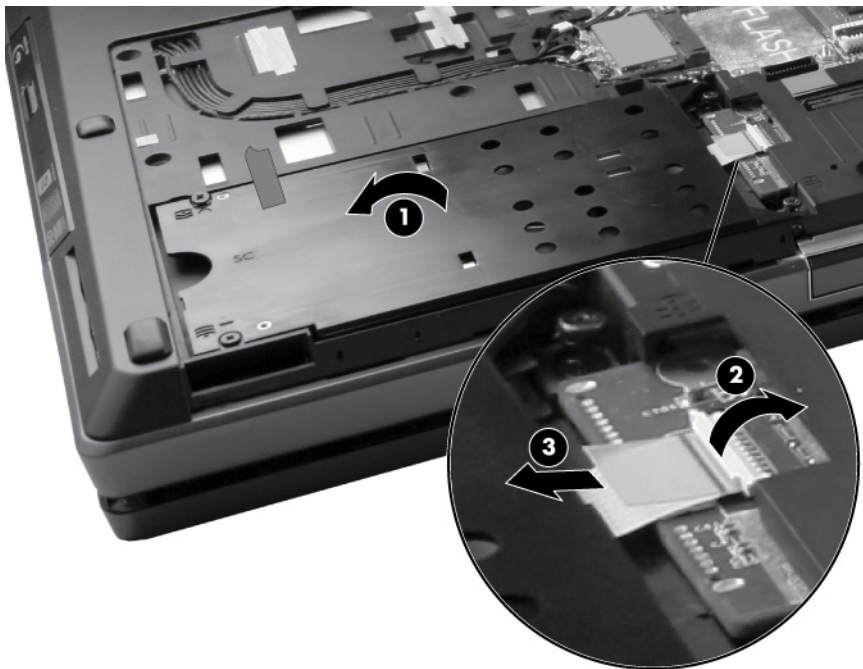

3. Reopen the door, tilt the door towards you **(1)**, and then lift the smart card reader door straight up from the computer **(2)**.

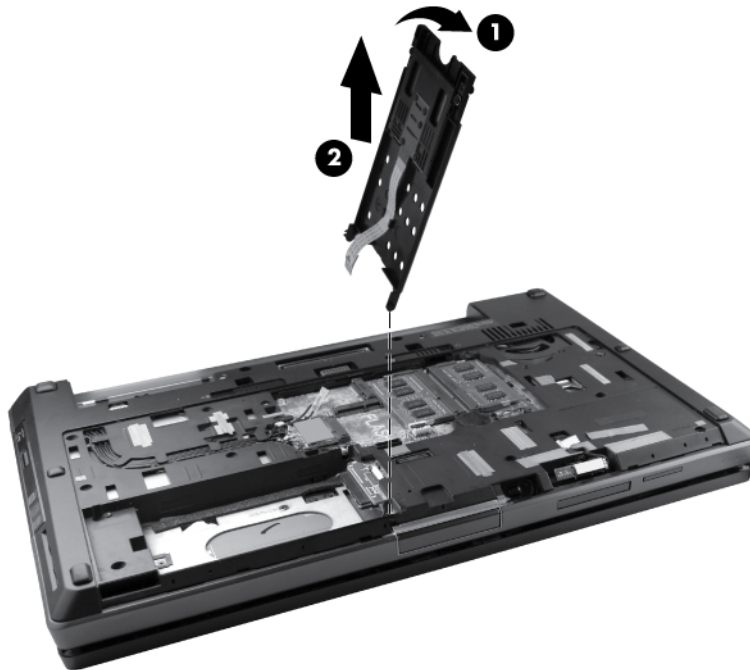

4. If it is necessary to replace the smart card reader, remove the two Phillips screws **(1)** that secure the smart card reader to the smart card reader door.
5. Slide the smart card reader out of the smart card reader door **(2)** while allowing the cable to slide out of the door guide **(3)**.

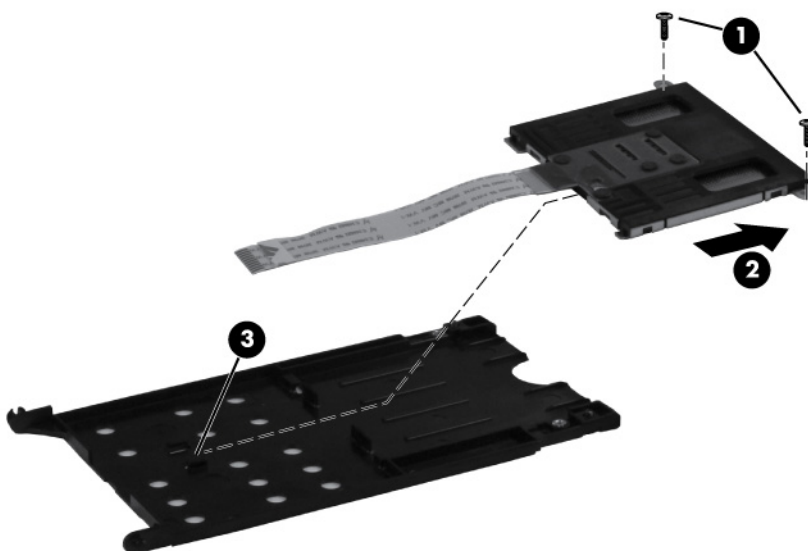

Reverse this procedure to reassemble and install the smart card reader.

Upgrade bay device

Optical drive

 **NOTE:** Computer models may be equipped with an optical drive or an upgrade bay hard drive.

All optical drive spare part kits include an optical drive bezel.

To remove the optical drive, see below.

To remove the upgrade bay hard drive, see following section.

Description	Spare part number
DVD-ROM Drive	694687-001
DVD±RW and CD-RW SuperMulti DL Combo Drive	694688-001
Blu-ray Disc ROM DVD±RW SuperMulti DL Combo Drive	694689-001
Blu-ray Disc R/RE DVD±RW SuperMulti DL Drive	694690-001

Before removing the optical drive, follow these steps:

1. Shut down the computer. If you are unsure whether the computer is off or in Hibernation, turn the computer on, and then shut it down through the operating system.
2. Disconnect all external devices connected to the computer.
3. Disconnect the power from the computer by first unplugging the power cord from the AC outlet, and then unplugging the AC adapter from the computer.
4. Remove the battery (see [Battery on page 54](#)).
5. Remove the service door (see [Service door on page 60](#)).

Remove the optical drive:

 **IMPORTANT:** Make special note of each screw and screw lock size and location during removal and replacement.

1. Position the computer upside down with the front side toward you.
2. Remove the Phillips locking screw **(1)** that secures the optical drive to the computer.
3. Insert a small tool **(2)** into the drive release opening and press the optical drive tab to the left.

4. Remove the optical drive **(3)** from the computer.

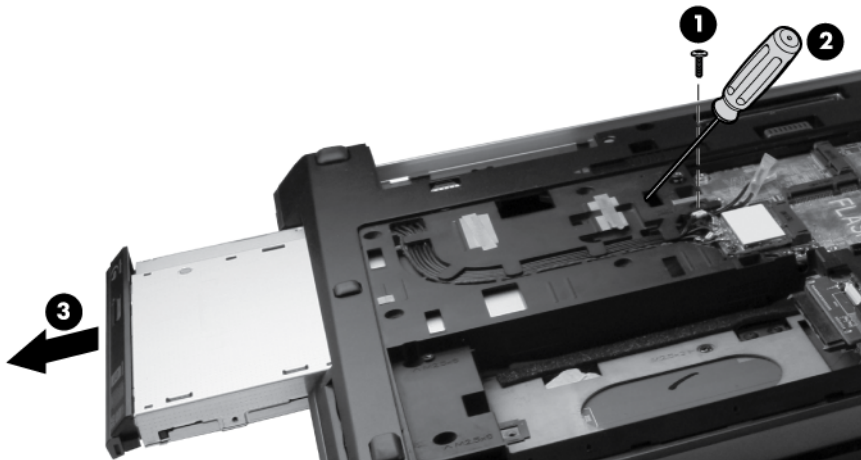

5. If it is necessary to replace the optical drive bracket, position the optical drive with the rear toward you.
6. Remove the three Phillips screws **(1)** that secure the optical drive bracket to the optical drive.
7. Remove the optical drive bracket **(2)**.

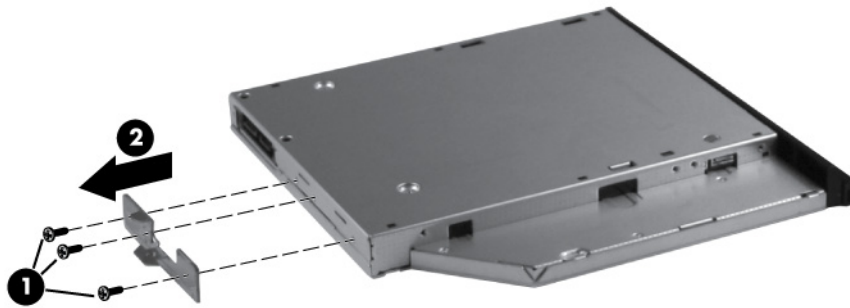

Reverse this procedure to install an optical drive.

Upgrade bay hard drive

Description	Spare part number
Upgrade bay bezel	655547-001

Before removing the upgrade bay hard drive, follow these steps:

1. Shut down the computer. If you are unsure whether the computer is off or in Hibernation, turn the computer on, and then shut it down through the operating system.
2. Disconnect all external devices connected to the computer.

3. Disconnect the power from the computer by first unplugging the power cord from the AC outlet, and then unplugging the AC adapter from the computer.
4. Remove the battery (see [Battery on page 54](#)).
5. Remove the service door (see [Service door on page 60](#)).

Remove the upgrade bay hard drive:

 **IMPORTANT:** Make special note of each screw and screw lock size and location during removal and replacement.

1. Position the computer upside down with the front side toward you.
2. Remove the four Phillips screws securing the hard drive.

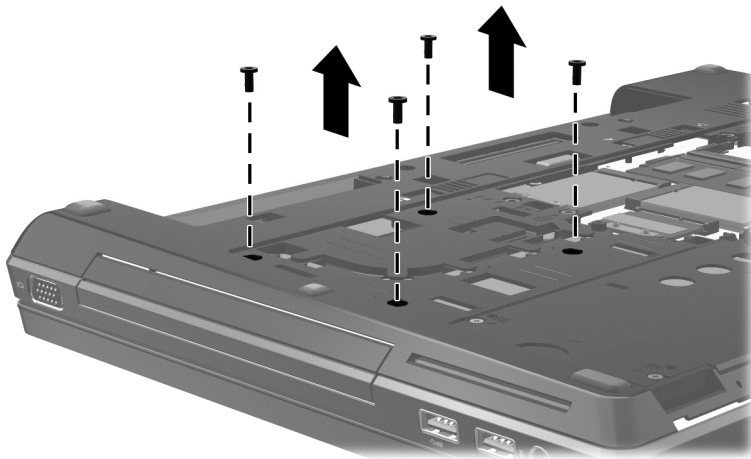

3. Remove the Phillips locking screw **(1)** that secures the upgrade bay bezel to the computer.
4. Insert a small tool **(2)** into the drive release opening and press the upgrade bay bezel tab to the left.
5. Remove the upgrade bay bezel **(3)** from the computer.



6. If it is necessary to remove the hard drive, position the upgrade bay bezel with the front toward you.
7. Loosen the two captive screws **(1)** that secure the hard drive to the bezel.
8. Lift the hard drive connector end up **(2)**. Lift the hard drive out at an angle **(3)**.

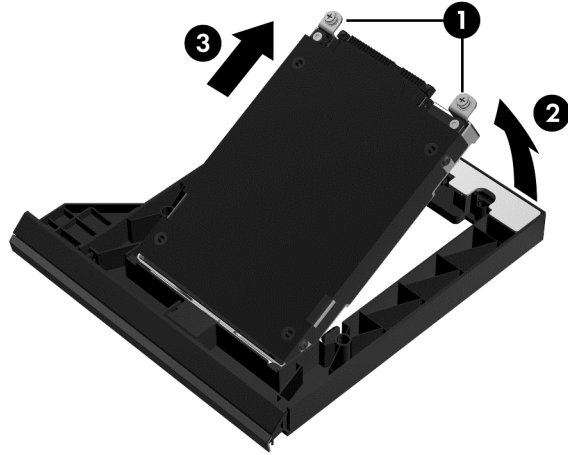

Reverse this procedure to install a hard drive in the upgrade bay.

Keyboard



NOTE: The keyboard spare part kit includes a keyboard cable, numeric keypad, pointing stick, and pointing stick cable.

For use in country/region	Spare part number	For use in country/region	Spare part number
Keyboard with backlight for use only on computer models equipped with the Windows 8 operating system (includes backlight cable):		For use in the Netherlands	703149-B31
For use in Belgium	703149-A41	For use in Norway	703149-091
For use in Canada	703149-DB1	For use in Russia	703149-251
For use in the Czech Republic and Slovakia	703149-FL1	For use in South Korea	703149-AD1
For use in Denmark	703149-081	For use in Sweden and Finland	703149-B71
For use in France	703149-051	For use in Switzerland	703149-BG1
For use in Germany	703149-041	For use in Taiwan	703149-AB1
For use in India	703149-D61	For use in Thailand	703149-281
For use in Italy	703149-061	For use in the United Kingdom and Singapore	703149-031
For use in Latin America	703149-161	For use in the United States	703149-001
Keyboard without backlight for use only on computer models equipped with the Windows 8 operating system:		For use in the Netherlands	703151-B31
For use in Belgium	703151-A41	For use in Norway	703151-091
For use in Brazil	703151-201	For use in Northwest Africa	703151-FP1
For use in Bulgaria	703151-261	For use in Portugal	703151-131
For use in Canada	703151-DB1	For use in Romania	703151-271
For use in the Czech Republic and Slovakia	703151-FL1	For use in Russia	703151-251
For use in Denmark	703151-081	For use in Saudi Arabia	703151-171
For use in France	703151-051	For use in Slovenia	703151-BA1
For use in Germany	703151-041	For use in South Korea	703151-AD1
For use in Greece	703151-151	For use in Spain	703151-071
For use in Hungary	703151-211	For use in Sweden and Finland	703151-B71
For use in Iceland	703151-DD1	For use in Switzerland	703151-BG1
For use in India	703151-D61	For use in Taiwan	703151-AB1
For use in Israel	703151-BB1	For use in Thailand	703151-281
For use in Italy	703151-061	For use in Turkey	703151-141

For use in country/region	Spare part number	For use in country/region	Spare part number
For use in Japan	703151-291	For use in the United Kingdom and Singapore	703151-031
For use in Latin America	703151-161	For use in the United States	703151-001
Keyboard with backlight for use only on computer models equipped with the Windows 7 operating system (includes backlight cable):		For use in the Netherlands	690647-B31
For use in Belgium	690647-A41	For use in Norway	690647-091
For use in the Canada	690647-DB1	For use in Russia	690647-251
For use in the Czech Republic and Slovakia	690647-FL1	For use in South Korea	690647-AD1
For use in Denmark	690647-081	For use in Sweden and Finland	690647-B71
For use in France	690647-051	For use in Switzerland	690647-BG1
For use in Germany	690647-041	For use in Taiwan	690647-AB1
For use in India	690647-D61	For use in Thailand	690647-281
For use in Italy	690647-061	For use in the United Kingdom and Singapore	690647-031
For use in Latin America	690647-161	For use in the United States	690647-001
Keyboard without backlight for use only on computer models equipped with the Windows 7 operating system:		For use in the Netherlands	690648-B31
For use in Belgium	690648-A41	For use in Norway	690648-091
For use in Brazil	690648-201	For use in Northwest Africa	690648-FP1
For use in Bulgaria	690648-261	For use in Portugal	690648-131
For use in Canada	690648-DB1	For use in Romania	690648-271
For use in the Czech Republic and Slovakia	690648-FL1	For use in Russia	690648-251
For use in Denmark	690648-081	For use in Saudi Arabia	690648-171
For use in France	690648-051	For use in Slovenia	690648-BA1
For use in Germany	690648-041	For use in South Korea	690648-AD1
For use in Greece	690648-151	For use in Spain	690648-071
For use in Hungary	690648-211	For use in Sweden and Finland	690648-B71
For use in Iceland	690648-DD1	For use in Switzerland	690648-BG1
For use in India	690648-D61	For use in Taiwan	690648-AB1
For use in Israel	690648-BB1	For use in Thailand	690648-281
For use in Italy	690648-061	For use in Turkey	690648-141

For use in country/region	Spare part number	For use in country/region	Spare part number
For use in Japan	690648-291	For use in the United Kingdom and Singapore	690648-031
For use in Latin America	690648-161	For use in the United States	690648-001

Before removing the keyboard, follow these steps:

 **IMPORTANT:** Make special note of each screw and screw lock size and location during removal and replacement.

1. Shut down the computer. If you are unsure whether the computer is off or in Hibernation, turn the computer on, and then shut it down through the operating system.
2. Disconnect all external devices connected to the computer.
3. Disconnect the power from the computer by first unplugging the power cord from the AC outlet, and then unplugging the AC adapter from the computer.
4. Remove the battery (see [Battery on page 54](#)).
5. Remove the service door (see [Service door on page 60](#)).
6. Remove the Upgrade bay device (see [Upgrade bay device on page 77](#)).

Remove the keyboard:

1. Turn the computer upside down, with the front toward you.
2. Loosen the three Phillips captive spring-loaded screws that secure the keyboard to the computer.

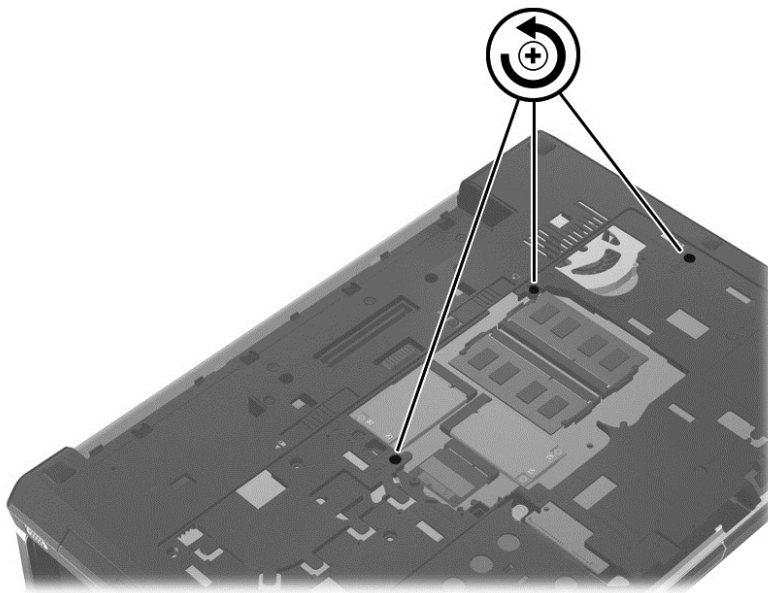

3. Open the computer and turn it on its side.

4. Insert a small, blunt tool into the release hole, and press on the keyboard until it disengages from the base enclosure.

 **NOTE:** The center of the keyboard is the release point. If the keyboard does not easily disengage, press on the keyboard through the opening in the upgrade bay area.

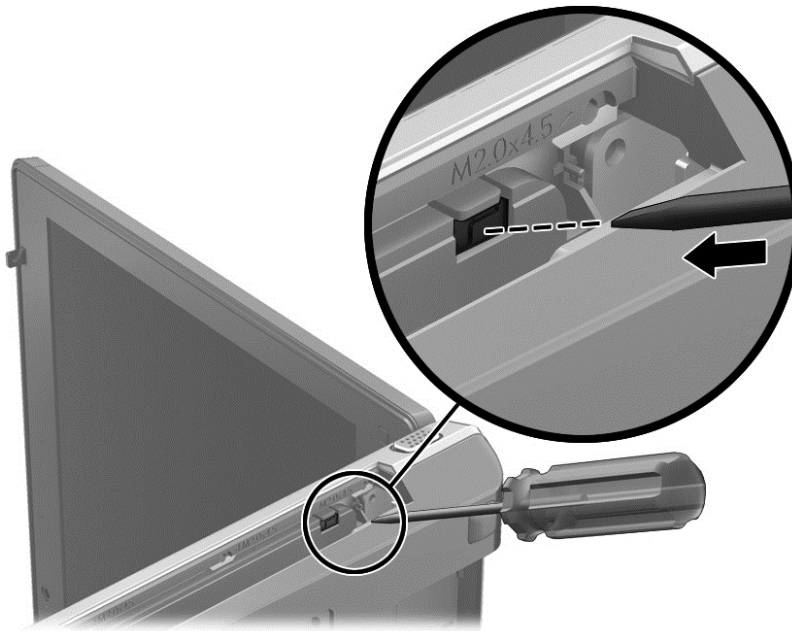

5. Turn the opened computer right-side up, with the front toward you.
6. Lift the rear edge of the keyboard and then rotate the keyboard **(3)** forward until it rests upside down on top of the TouchPad.



 **NOTE:** If you are accessing the memory modules below the keyboard, it is not necessary to remove the cables or keyboard.

7. Release the ZIF connector for the pointing stick cable **(1)** and then disconnect the cable from the system board **(2)**.

8. Release the ZIF connector for the keyboard cable (3), and then disconnect the cable from the system board (4).
9. If so equipped, release the ZIF connector for the keyboard backlight cable (5) and then disconnect the cable from the system board (6).

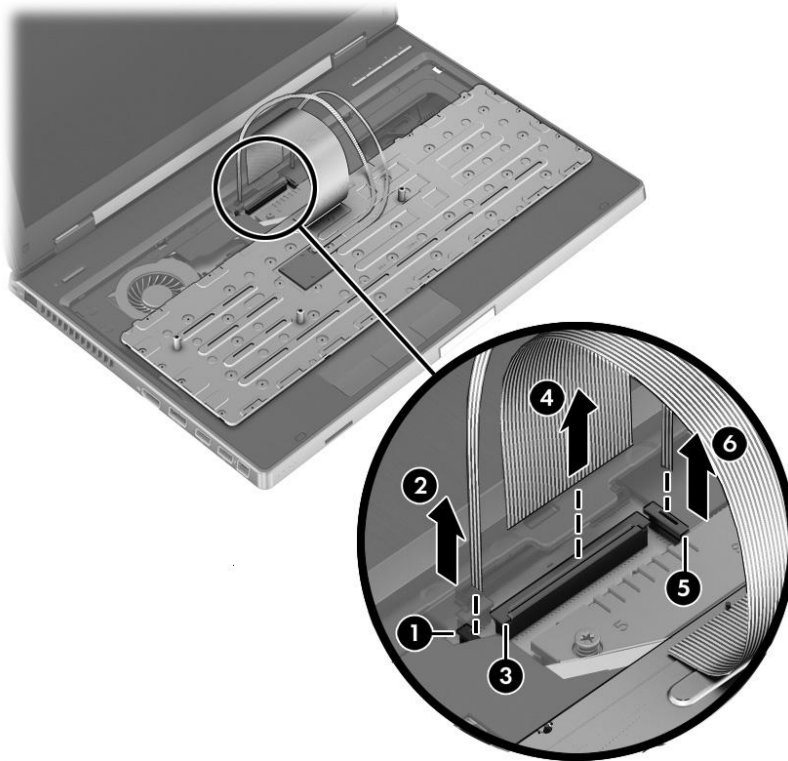

10. Remove the keyboard.

Reverse this procedure to install the keyboard.

Memory Modules (under keyboard)

NOTE: A computer having a system board with spare part number 690643-001 or 696441-001 has four memory slots. In this case, the primary memory is located under the keyboard and expansion memory is located under the service door.

A computer having a system board with spare part number 690642-001 or 696440-001 has two memory module slots. In this case, the primary memory is located under the service door.

To access memory modules under the service door, see [Memory Modules \(under service door\) on page 62](#)

Description	Spare part number
8 GB (DDR3 1600MHz PC3-12800)	670034-001
4 GB (DDR3 1600MHz PC3-12800)	641369-001
2 GB (DDR3 1600MHz PC3-12800)	652972-001

Before removing a memory module, follow these steps:

 **IMPORTANT:** Make special note of each screw and screw lock size and location during removal and replacement.

1. Shut down the computer. If you are unsure whether the computer is off or in Hibernation, turn the computer on, and then shut it down through the operating system.
2. Disconnect all external devices connected to the computer.
3. Disconnect the power from the computer by first unplugging the power cord from the AC outlet, and then unplugging the AC adapter from the computer.
4. Remove the battery (see [Battery on page 54](#)).
5. Remove the service door (see [Service door on page 60](#)).
6. Remove the following components:
 - a. Upgrade bay device (see [Upgrade bay device on page 77](#)).
 - b. Keyboard (see [Keyboard on page 81](#)).

Remove the memory module:

1. Spread the retaining tabs **(1)** on each side of the memory module slot to release the memory module. (The edge of the module opposite the slot rises away from the computer.)
2. Remove the memory module **(2)** by pulling the module away from the slot at an angle.

 **NOTE:** Memory modules are designed with a notch to prevent incorrect insertion into the memory module slot.

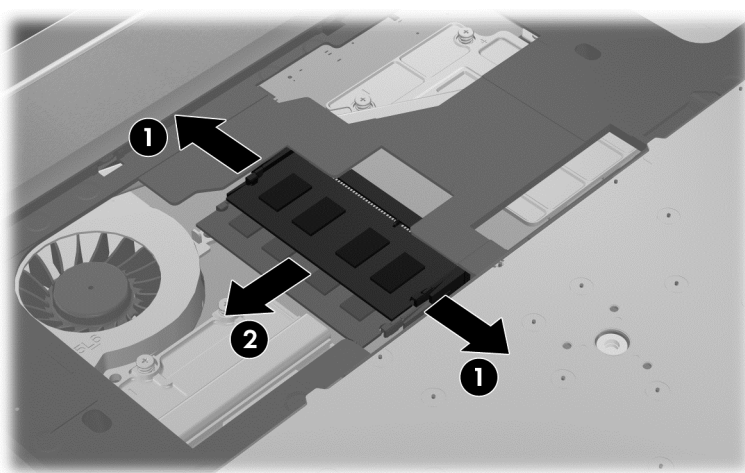

Reverse this procedure to install memory module.

Top cover

The top covers include TouchPad button and bracket.

Description	Spare part number
For use on computer models with a fingerprint reader	652652-001

Before removing the top cover, follow these steps:



IMPORTANT: Make special note of each screw and screw lock size and location during removal and replacement.

1. Shut down the computer. If you are unsure whether the computer is off or in Hibernation, turn the computer on, and then shut it down through the operating system.
2. Disconnect all external devices connected to the computer.
3. Disconnect the power from the computer by first unplugging the power cord from the AC outlet, and then unplugging the AC adapter from the computer.
4. Remove the battery (see [Battery on page 54](#)).
5. Remove the service door (see [Service door on page 60](#)).
6. Remove the following components:
 - a. Hard drive (see [Hard drive on page 72](#)).
 - b. Upgrade bay device (see [Upgrade bay device on page 77](#)).
 - c. Keyboard (see [Keyboard on page 81](#)).

Remove the top cover:

1. Turn the computer right-side up.
2. Release the following ZIF connectors **(1)** and disconnect the corresponding cables **(2)** from the system board:
 - Power button ZIF connector
 - TouchPad ZIF cable
 - TouchPad buttons ZIF cable
 - Fingerprint reader ZIF cable
 - Application buttons ZIF cable

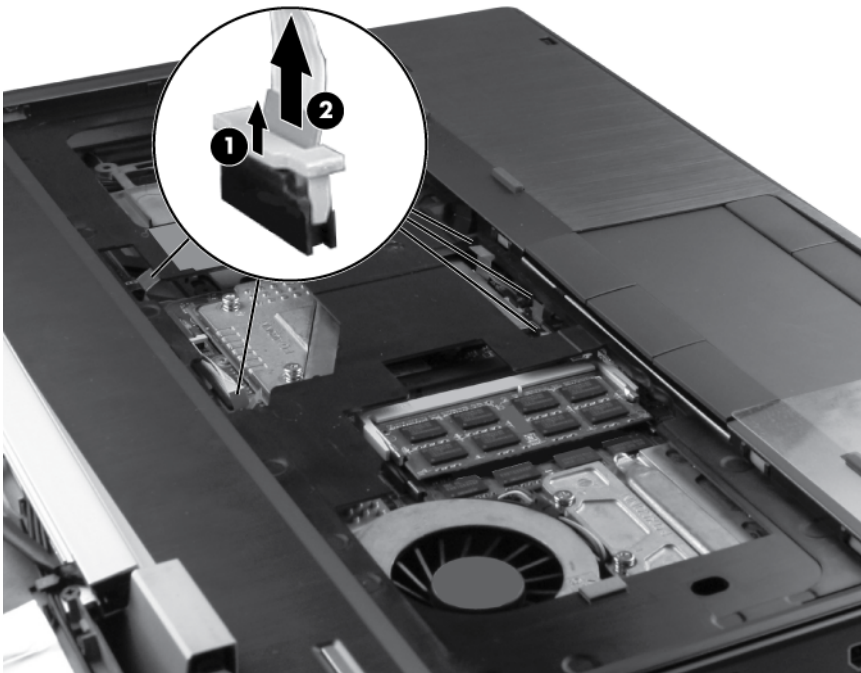

3. Remove the following screws that secure the top cover to the base enclosure:
- Three Phillips screws from the Upgrade bay **(1)**.
 - Three Torx 8 screws in the hard drive bay and four Torx 8 screws in the battery bay **(2)**.
 - Five Torx 8 screws from the front edge and middle of the computer **(3)**.

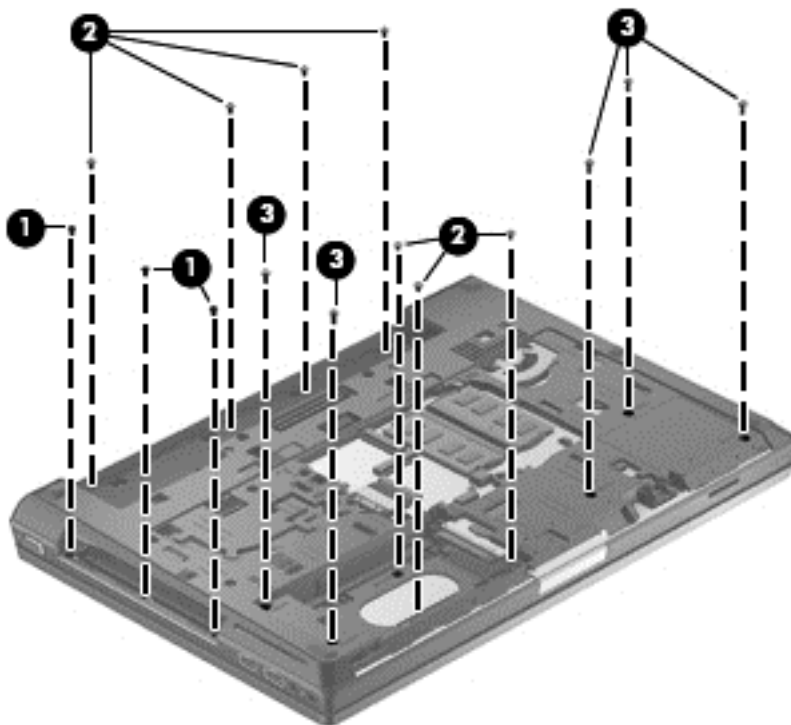

4. Pull up the back edge **(1)** of the top cover, and then lift the cover **(2)** away at an angle.

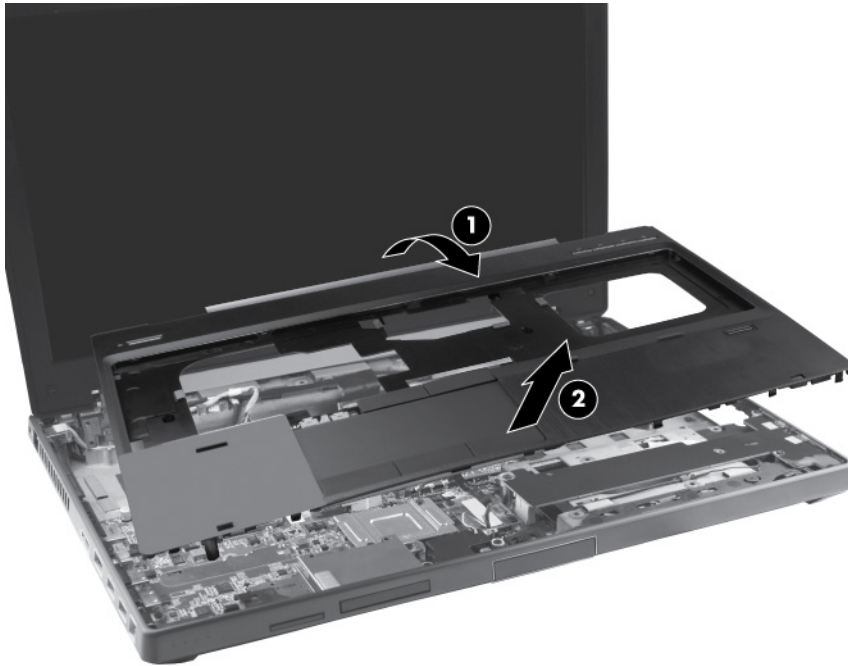

Reverse this procedure to install the top cover.

Power button board

Description	Spare part number
Power button board	690634-001

Before removing the power button board, follow these steps:



IMPORTANT: Make special note of each screw and screw lock size and location during removal and replacement.

1. Shut down the computer. If you are unsure whether the computer is off or in Hibernation, turn the computer on, and then shut it down through the operating system.
2. Disconnect all external devices connected to the computer.
3. Disconnect the power from the computer by first unplugging the power cord from the AC outlet, and then unplugging the AC adapter from the computer.
4. Remove the battery (see [Battery on page 54](#)).
5. Remove the service door (see [Service door on page 60](#)).
6. Remove the following components:
 - a. Hard drive (see [Hard drive on page 72](#)).
 - b. Upgrade bay device (see [Upgrade bay device on page 77](#)).
 - c. Keyboard (see [Keyboard on page 81](#)).
 - d. Top cover (see [Top cover on page 87](#)).

Remove the power button board:

1. Position the top cover upside down, with the front toward you.
2. Remove the two pieces of tape from the top of the power button board **(1)**.
3. Release the ZIF connector **(2)** for the power button board cable and then disconnect the cable **(3)**.

4. Remove the two Torx 8 screws **(4)** that secure the power button board to the top cover and then remove the power button board **(5)**.

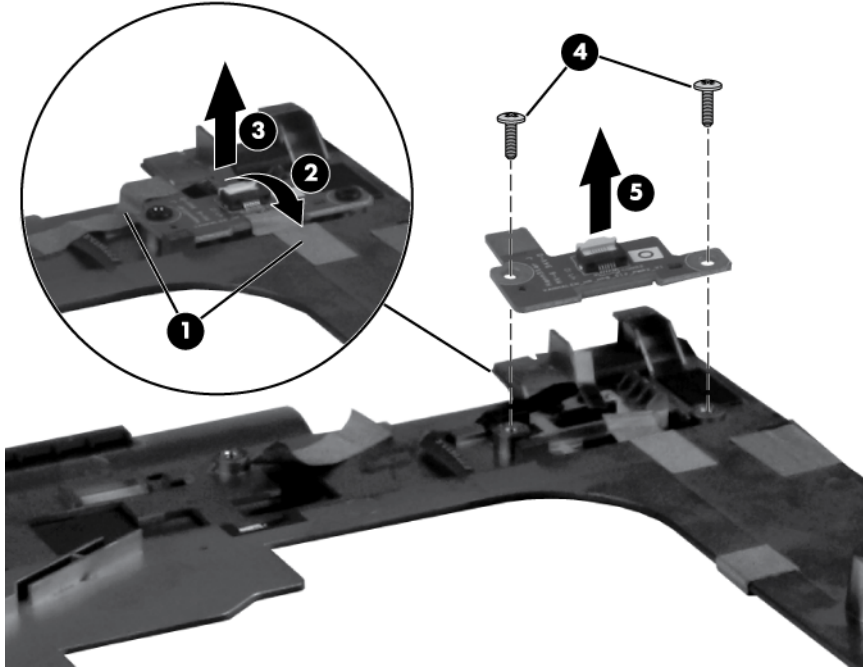

Reverse this procedure to install the power button board.

Function button board

Description	Spare part number
Function button board (includes cable)	690635-001

Before removing the function button board, follow these steps:



IMPORTANT: Make special note of each screw and screw lock size and location during removal and replacement.

1. Shut down the computer. If you are unsure whether the computer is off or in Hibernation, turn the computer on, and then shut it down through the operating system.
2. Disconnect all external devices connected to the computer.
3. Disconnect the power from the computer by first unplugging the power cord from the AC outlet, and then unplugging the AC adapter from the computer.
4. Remove the battery (see [Battery on page 54](#)).
5. Remove the service door (see [Service door on page 60](#)).
6. Remove the following components:
 - a. Hard drive (see [Hard drive on page 72](#)).
 - b. Upgrade bay device (see [Upgrade bay device on page 77](#)).
 - c. Keyboard (see [Keyboard on page 81](#)).
 - d. Top cover (see [Top cover on page 87](#)).

Remove the function button board:

1. Position the top cover upside down, with the front toward you.
2. Remove the tape **(1)** from the top of the function button board.
3. Remove the two Torx 8 screws **(2)** that secure the function button board to the top cover.
4. Lift the function button board **(3)** from the top cover.

5. Disconnect the function button board cable (4) from the function button board.

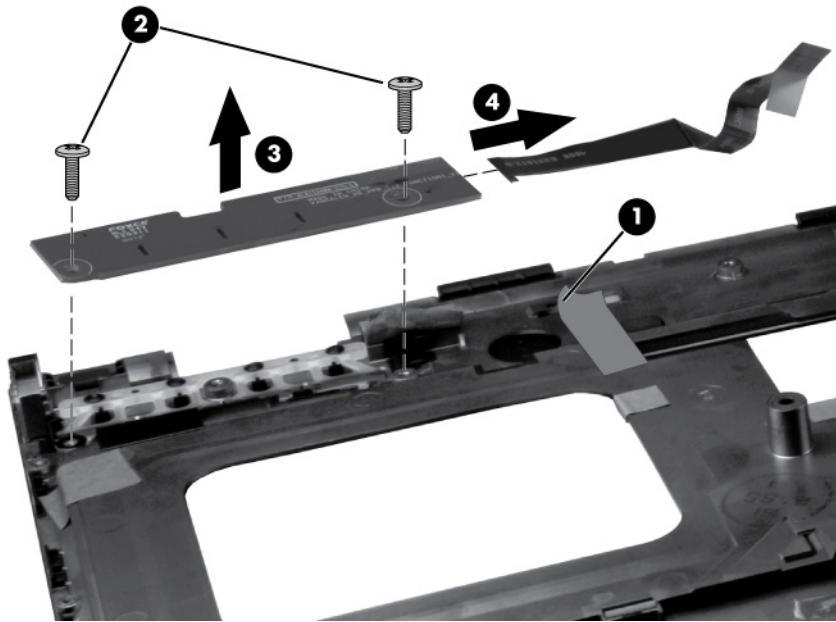

Reverse this procedure to install the function button board.

Fingerprint reader board

Description	Spare part number
Fingerprint reader board (includes bracket)	690631-001

Before removing the fingerprint reader board, follow these steps:



IMPORTANT: Make special note of each screw and screw lock size and location during removal and replacement.

1. Shut down the computer. If you are unsure whether the computer is off or in Hibernation, turn the computer on, and then shut it down through the operating system.
2. Disconnect all external devices connected to the computer.
3. Disconnect the power from the computer by first unplugging the power cord from the AC outlet, and then unplugging the AC adapter from the computer.
4. Remove the battery (see [Battery on page 54](#)).
5. Remove the service door (see [Service door on page 60](#)).
6. Remove the following components:
 - a. Hard drive (see [Hard drive on page 72](#)).
 - b. Upgrade bay device (see [Upgrade bay device on page 77](#)).
 - c. Keyboard (see [Keyboard on page 81](#)).
 - d. Top cover (see [Top cover on page 87](#)).

Remove the fingerprint reader board:

1. Position the top cover upside down, with the front toward you.
2. Remove the Phillips screw **(1)** that secures the fingerprint reader board to the top cover.
3. Remove the fingerprint reader board bracket **(2)** from the fingerprint reader board.

4. Lift the fingerprint reader board (3) from the top cover.

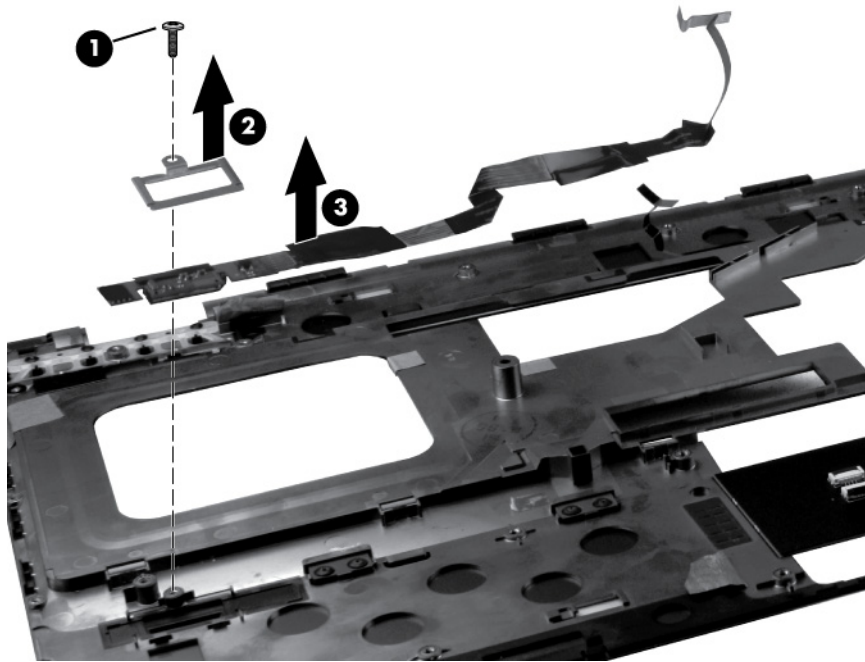

Reverse this procedure to install the fingerprint reader board.

TouchPad button board

Description	Spare part number
TouchPad button board (included with top cover, spare part number 652652-001)	

Before removing the TouchPad button board, follow these steps:



IMPORTANT: Make special note of each screw and screw lock size and location during removal and replacement.

1. Shut down the computer. If you are unsure whether the computer is off or in Hibernation, turn the computer on, and then shut it down through the operating system.
2. Disconnect all external devices connected to the computer.
3. Disconnect the power from the computer by first unplugging the power cord from the AC outlet, and then unplugging the AC adapter from the computer.
4. Remove the battery (see [Battery on page 54](#)).
5. Remove the service door (see [Service door on page 60](#)).
6. Remove the following components:
 - a. Hard drive (see [Hard drive on page 72](#)).
 - b. Upgrade bay device (see [Upgrade bay device on page 77](#)).
 - c. Keyboard (see [Keyboard on page 81](#)).
 - d. Top cover (see [Top cover on page 87](#)).

Remove the TouchPad button board:

1. Position the top cover upside down, with the front toward you.
2. Release the ZIF connector **(1)** for the TouchPad button board cable and then disconnect the cable **(2)**.
3. Remove the four Torx 8 screws **(3)** that secure the TouchPad button board to the top cover.

4. Lift the TouchPad button board (4) from the top cover.

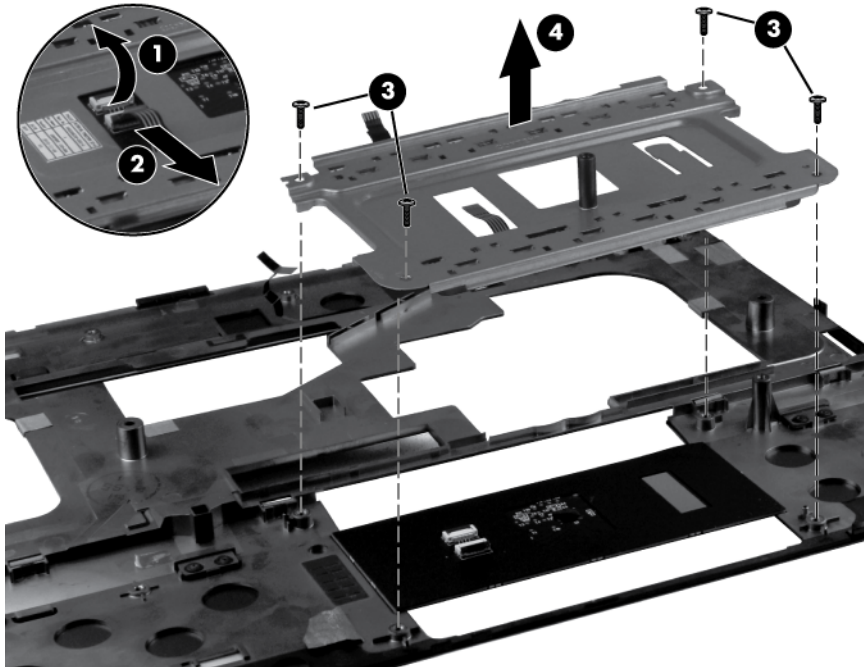
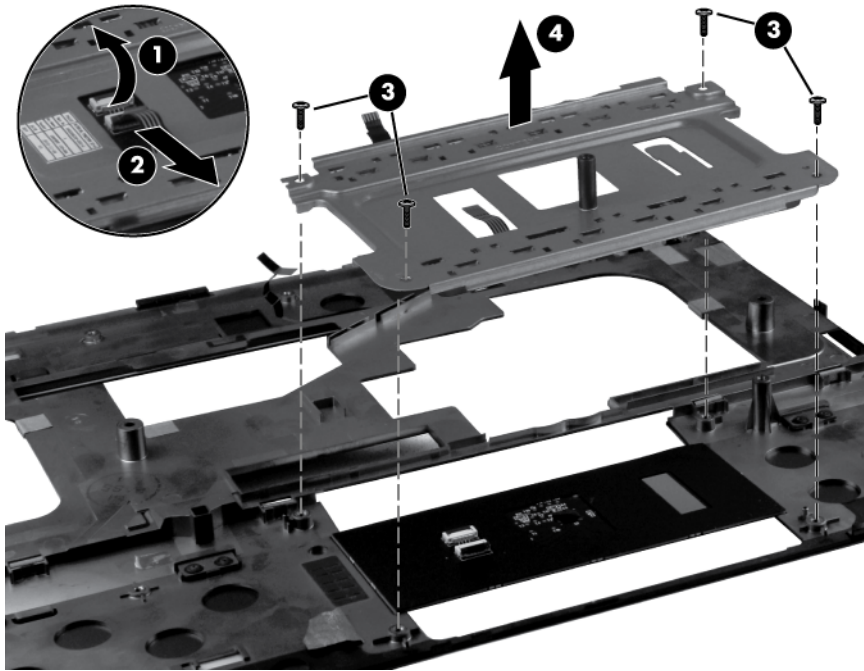

Reverse this procedure to install the TouchPad button board.

VGA port board

Description	Spare part number
VGA port board	690641-001

Before removing the VGA port board, follow these steps:



IMPORTANT: Make special note of each screw and screw lock size and location during removal and replacement.

1. Shut down the computer. If you are unsure whether the computer is off or in Hibernation, turn the computer on, and then shut it down through the operating system.
2. Disconnect all external devices connected to the computer.
3. Disconnect the power from the computer by first unplugging the power cord from the AC outlet, and then unplugging the AC adapter from the computer.
4. Remove the battery (see [Battery on page 54](#)).
5. Remove the service door (see [Service door on page 60](#)).
6. Remove the following components:
 - a. Hard drive (see [Hard drive on page 72](#)).
 - b. Upgrade bay device (see [Upgrade bay device on page 77](#)).
 - c. Keyboard (see [Keyboard on page 81](#)).
 - d. Top cover (see [Top cover on page 87](#)).

Remove the VGA port board:

1. Position the computer right-side up with the front toward you.
2. Remove the Phillips screw **(1)** that secures the VGA port board to the base enclosure.
3. Remove the two Torx 8 screws **(2)** that secure the VGA port board to the base enclosure.

4. Lift and remove the VGA port board from the base enclosure.

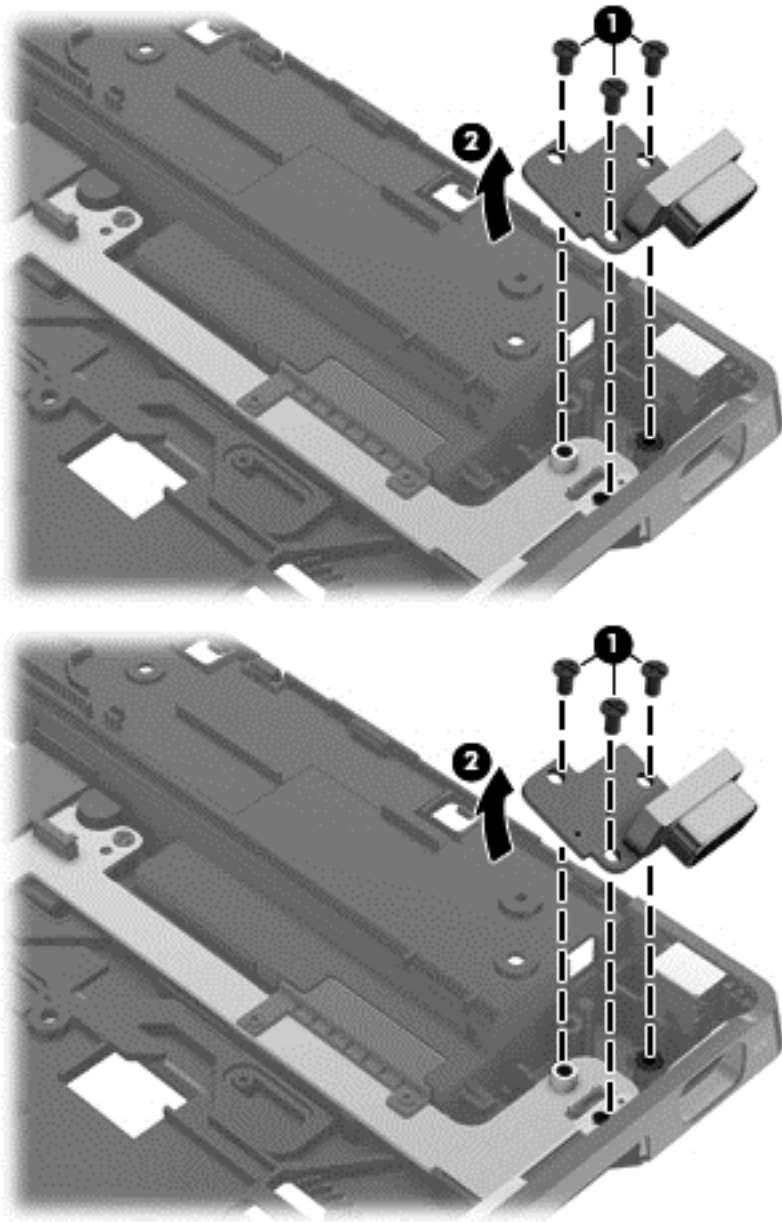

Reverse this procedure to install the VGA port board.

Fan and heat sink assembly

Description	Spare part number
Fan and heat sink assembly for use in computers with AMD FirePro M4000 graphics cards	690628-001
Fan and heat sink assembly for use in computers with NVIDIA Quadro K2000M graphics cards	690630-001
Fan and heat sink assembly for use in computers with NVIDIA Quadro K1000M graphics cards	690629-001

Before removing the fan and heat sink assembly, follow these steps:

 **IMPORTANT:** Make special note of each screw and screw lock size and location during removal and replacement.

1. Shut down the computer. If you are unsure whether the computer is off or in Hibernation, turn the computer on, and then shut it down through the operating system.
2. Disconnect all external devices connected to the computer.
3. Disconnect the power from the computer by first unplugging the power cord from the AC outlet, and then unplugging the AC adapter from the computer.
4. Remove the battery (see [Battery on page 54](#)).
5. Remove the service door (see [Service door on page 60](#)).
6. Remove the following components:
 - a. Hard drive (see [Hard drive on page 72](#)).
 - b. Upgrade bay device (see [Upgrade bay device on page 77](#)).
 - c. Keyboard (see [Keyboard on page 81](#)).
 - d. Top cover (see [Top cover on page 87](#)).

Remove the fan and heat sink assembly:

1. Position the computer right-side up, with the front toward you.
2. Disconnect the fan cable **(1)** from the system board.
3. Loosen the eight captive screws **(2)** that secure the video card heat sink to the base enclosure following the sequence embossed in the heat sinks.

- Lift the fan and heat sink assembly from the base enclosure **(3)**.

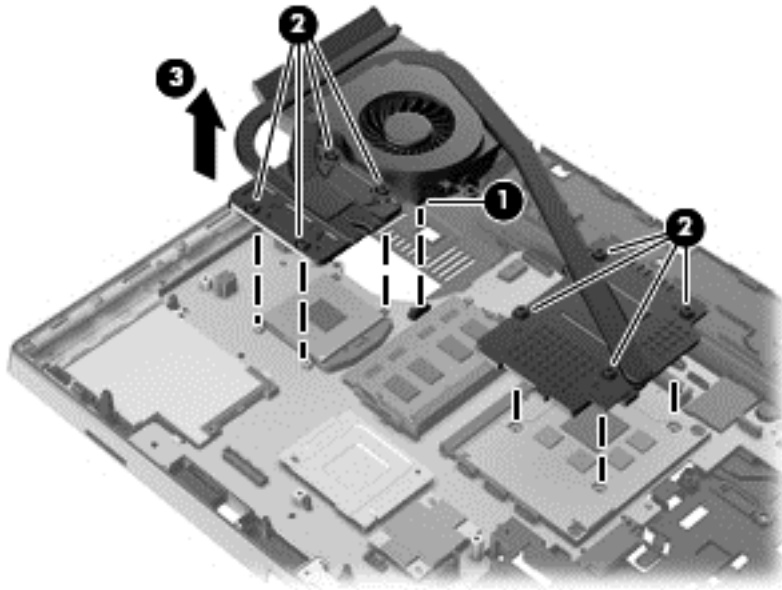

 **NOTE:** The thermal material must be thoroughly cleaned from the surfaces of the system board **(1)**, **(3)**, **(5)**, and **(7)** and the heat sinks **(2)**, **(4)**, **(6)**, and **(8)**, each time the heat sink is removed. Replacement thermal material is included with all heat sink and system board spare part kits.

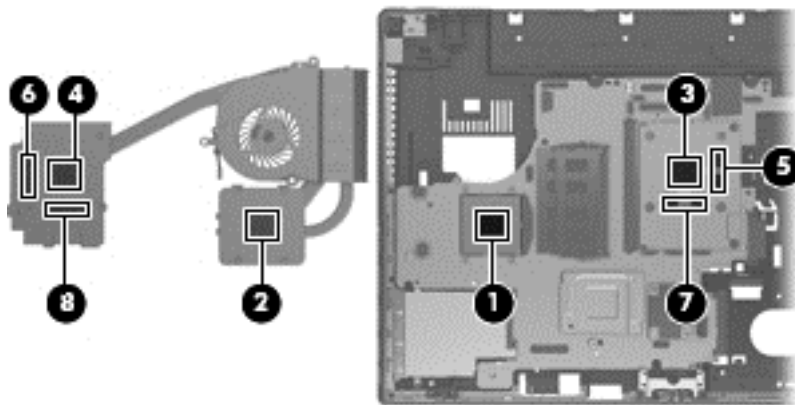

Reverse this procedure to install the fan and heat sink assembly.

 **NOTE:** To properly ventilate the computer, allow at least a 7.6 cm (3 in) clearance on the left side of the computer.

The computer uses an electric fan for ventilation. The fan is controlled by a temperature sensor and is designed to turn on automatically when high temperature conditions exist. These conditions are affected by high external temperatures, system power consumption, power management/battery conservation configurations, battery fast charging, and software requirements. Exhaust air is displaced through the ventilation grill located on the left side of the computer.

Graphics card

 **NOTE:** All graphics card spare part kits include replacement thermal material.

Description	Spare part number
NVIDIA Quadro K2000M (NVIDIA N14P-Q3 2GB DDR3)	690637-001
NVIDIA Quadro K1000M (NVIDIA N14P-Q1 2GB DDR3)	690638-001
AMD FirePro M4000 (Chelsea XT GL 1GB GDDR5)	690639-001

Before removing the graphics card, follow these steps:

 **IMPORTANT:** Make special note of each screw and screw lock size and location during removal and replacement.

1. Shut down the computer. If you are unsure whether the computer is off or in Hibernation, turn the computer on, and then shut it down through the operating system.
2. Disconnect all external devices connected to the computer.
3. Disconnect the power from the computer by first unplugging the power cord from the AC outlet, and then unplugging the AC adapter from the computer.
4. Remove the battery (see [Battery on page 54](#)).
5. Remove the service door (see [Service door on page 60](#)).
6. Remove the following components:
 - a. Hard drive (see [Hard drive on page 72](#)).
 - b. Upgrade bay device (see [Upgrade bay device on page 77](#)).
 - c. Keyboard (see [Keyboard on page 81](#)).
 - d. Top cover (see [Top cover on page 87](#)).
 - e. Fan and heat sink assembly (see [Fan and heat sink assembly on page 100](#)).

Remove the graphics card:

1. Position the computer right-side up, with the front toward you.
2. Remove the two Torx 8 screws **(1)** that secure the graphics card to the computer. (The edge of the board opposite the graphics card slot rises away from the computer.)

3. Remove the graphics card **(2)** by sliding it away from the slot at an angle.

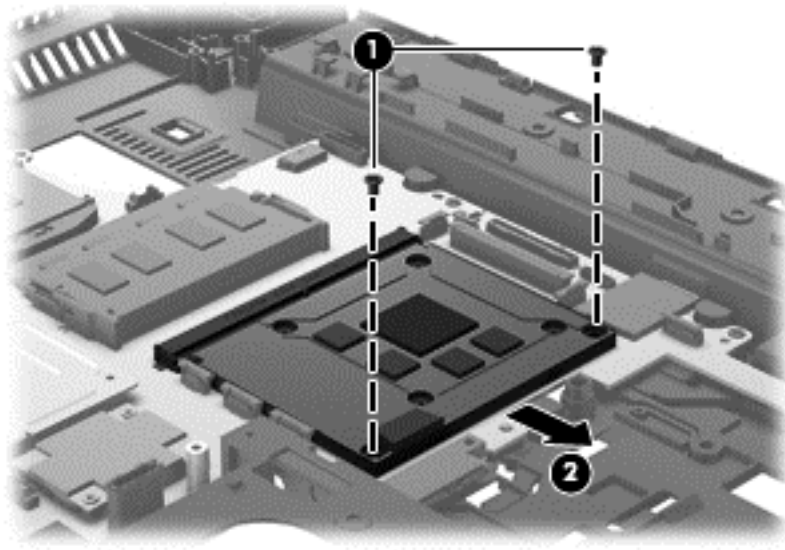

 **NOTE:** The thermal material must be thoroughly cleaned from the surfaces of the system board **(1)**, **(3)**, **(5)**, and **(7)** and the heat sinks **(2)**, **(4)**, **(6)**, and **(8)**, each time the heat sink is removed. Replacement thermal material is included with all heat sink and system board spare part kits.

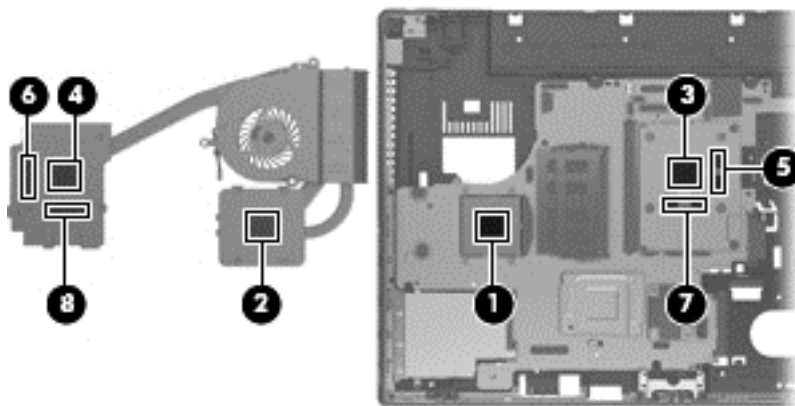

Reverse this procedure to install the graphics card.

Processor



NOTE: All processor spare part kits include replacement thermal material.

Description	Spare part number
Intel Quad Core i7-3840QM 2.80-GHz processor (SC turbo up to 3.80-GHz; 1600-MHz FSB, 8.0-MB L3 cache, 45 W)	703266-002
i7-3820QM, 2.70 GHz (Turbo up to 3.70 GHz), quad-core processor, 1600 MHz, 8 MB L3 Cache, 8 threads, 45W	681284-002
Intel Quad Core i7-3740QM 2.70-GHz processor (SC turbo up to 3.70-GHz; 1600-MHz FSB, 6.0-MB L3 cache, 45 W)	702840-002
i7-3720QM, 2.60GHz (Turbo up to 3.60 GHz), quad-core processor, 1600 MHz, 6 MB L3 Cache, 8 threads, 45W	681283-002
Intel Quad Core i7-3630QM 2.40-GHz processor (SC turbo up to 3.40-GHz; 1600-MHz FSB, 6.0-MB L3 cache, 45 W)	702081-002
i7-3610QM, 2.30 GHz (Turbo up to 3.30 GHz), quad-core processor 1600 MHz, 6MB L3 Cache, 8 threads, 45W	680646-002
i7-3520M, 2.90GHz (Turbo up to 3.60 GHz), dual-core processor, 1600 MHz, 4MB L3 Cache, 4 threads, 35W	681954-002
i5-3360M, 2.80 GHz (Turbo up to 3.50 GHz), dual-core processor, 1600 MHz, 3 MB L3 Cache, 4 threads, 35W	681953-002
i5-3320M, 2.60 GHz (Turbo up to 3.30 GHz), dual-core processor, 1600 MHz, 3 MB L3 Cache, 4 threads, 35W	681952-002

Before removing the processor, follow these steps:



IMPORTANT: Make special note of each screw and screw lock size and location during removal and replacement.

1. Shut down the computer. If you are unsure whether the computer is off or in Hibernation, turn the computer on, and then shut it down through the operating system.
2. Disconnect all external devices connected to the computer.
3. Disconnect the power from the computer by first unplugging the power cord from the AC outlet, and then unplugging the AC adapter from the computer.
4. Remove the battery (see [Battery on page 54](#)).
5. Remove the service door (see [Service door on page 60](#)).
6. Remove the following components:
 - a. Hard drive (see [Hard drive on page 72](#)).
 - b. Upgrade bay device (see [Upgrade bay device on page 77](#)).
 - c. Keyboard (see [Keyboard on page 81](#)).

- d. Top cover (see [Top cover on page 87](#)).
- e. Fan and heat sink assembly (see [Fan and heat sink assembly on page 100](#)).

Remove the processor:

1. Position the computer right-side up, with the front toward you.
2. Use a flat-bladed screwdriver to turn the processor locking screw **(1)** one-half turn counterclockwise until you hear a click.
3. Lift the processor **(2)** straight up and remove it.

 **NOTE:** The gold triangle **(3)** on the processor must be aligned with the triangle embossed on the processor slot when you install the processor.

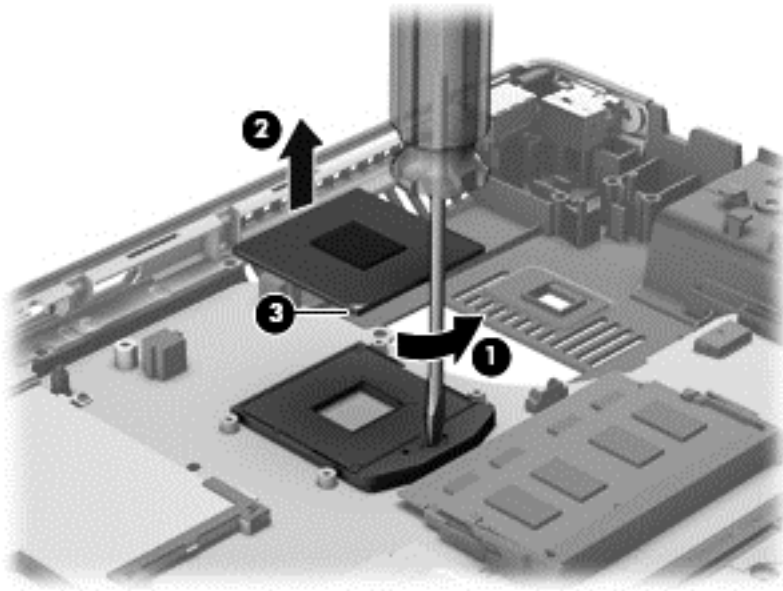

Reverse this procedure to install the processor.

Audio/USB 3.0 board

Description	Spare part number
Audio/USB 3.0 board (select models only)	690636-001

Before removing the audio/USB 3.0 board, follow these steps:



IMPORTANT: Make special note of each screw and screw lock size and location during removal and replacement.

1. Shut down the computer. If you are unsure whether the computer is off or in Hibernation, turn the computer on, and then shut it down through the operating system.
2. Disconnect all external devices connected to the computer.
3. Disconnect the power from the computer by first unplugging the power cord from the AC outlet, and then unplugging the AC adapter from the computer.
4. Remove the battery (see [Battery on page 54](#)).
5. Remove the service door (see [Service door on page 60](#)).
6. Remove the following components:
 - a. Hard drive (see [Hard drive on page 72](#)).
 - b. Upgrade bay device (see [Upgrade bay device on page 77](#)).
 - c. Keyboard (see [Keyboard on page 81](#)).
 - d. Top cover (see [Top cover on page 87](#)).

Remove the audio/USB 3.0 board:

1. Turn the computer right-side up, with the front toward you.
2. Remove the three Torx 8 screws **(1)** that secure the audio/USB 3.0 board to the system board.

3. Disconnect the audio/USB 3.0 board **(2)** from the system board by lifting it out at an angle.

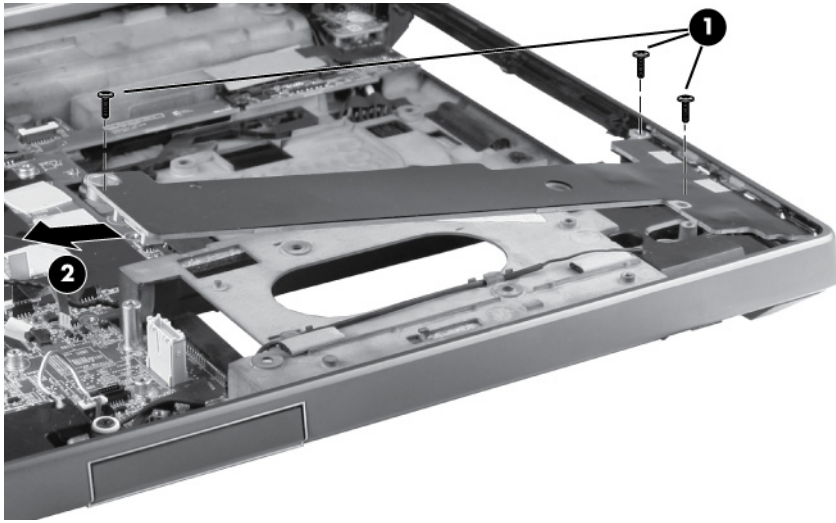

Reverse this procedure to install the audio/USB 3.0 board.

Modem module

 **NOTE:** The modem module spare part kit does not include a modem module cable. The modem module cable is included in the cable kit, spare part number 690623-001. For information about cable kit contents, see [Cable Kit on page 33](#).

Description	Spare part number
56k v.92 MDC data/fax modem module	628824-001

Before removing the modem module, follow these steps:

 **IMPORTANT:** Make special note of each screw and screw lock size and location during removal and replacement.

1. Shut down the computer. If you are unsure whether the computer is off or in Hibernation, turn the computer on, and then shut it down through the operating system.
2. Disconnect all external devices connected to the computer.
3. Disconnect the power from the computer by first unplugging the power cord from the AC outlet, and then unplugging the AC adapter from the computer.
4. Remove the battery (see [Battery on page 54](#)).
5. Remove the service door (see [Service door on page 60](#)).
6. Remove the following components:
 - a. Hard drive (see [Hard drive on page 72](#)).
 - b. Upgrade bay device (see [Upgrade bay device on page 77](#)).
 - c. Keyboard (see [Keyboard on page 81](#)).
 - d. Top cover (see [Top cover on page 87](#)).
 - e. Audio/USB 3.0 board (see [Audio/USB 3.0 board on page 106](#)).

Remove the modem module:

1. Turn the computer right-side up, with the front toward you.
2. Disconnect the modem module cable **(1)** from the system board.
3. Remove the two Phillips barrel screws **(2)** that secure the modem module to the system board.

4. Disconnect the modem module **(3)** from the system board by lifting it straight up.

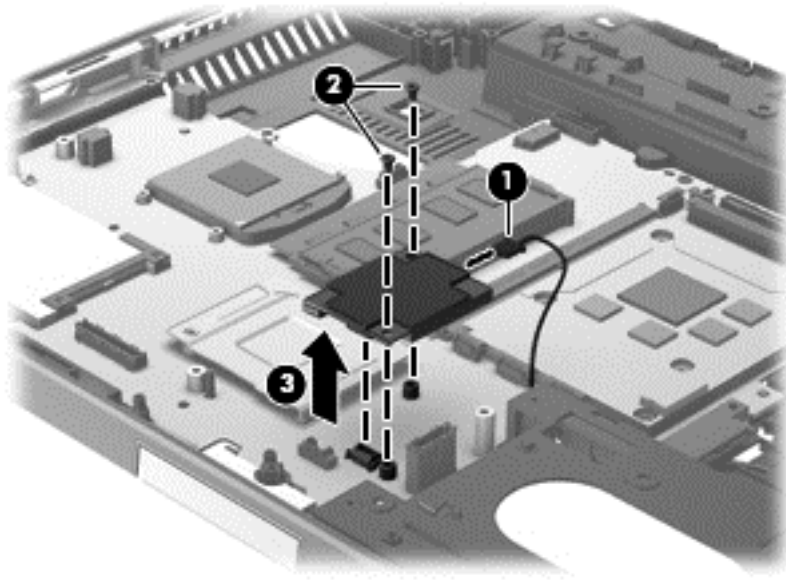

Reverse this procedure to install the modem module.

Speakers

Description	Spare part number
Speaker kit	652669-001

Before removing the speakers, follow these steps:



IMPORTANT: Make special note of each screw and screw lock size and location during removal and replacement.

1. Shut down the computer. If you are unsure whether the computer is off or in Hibernation, turn the computer on, and then shut it down through the operating system.
2. Disconnect all external devices connected to the computer.
3. Disconnect the power from the computer by first unplugging the power cord from the AC outlet, and then unplugging the AC adapter from the computer.
4. Remove the battery (see [Battery on page 54](#)).
5. Remove the service door (see [Service door on page 60](#)).
6. Remove the following components:
 - a. Hard drive (see [Hard drive on page 72](#)).
 - b. Upgrade bay device (see [Upgrade bay device on page 77](#)).
 - c. Keyboard (see [Keyboard on page 81](#)).
 - d. Top cover (see [Top cover on page 87](#)).
 - e. Audio/USB 3.0 board (see [Audio/USB 3.0 board on page 106](#)).

Remove the speakers:

1. Position the computer right-side up, with the front toward you.
2. Remove the display latch:
 - a. Remove the spring **(1)** from the display latch lock.
 - b. Remove the three Phillips screws **(2)** from the display latch lock.
 - c. Push down the button **(3)** in the front right corner of the display latch lock.

- d. Slide the display latch lock to the left and remove by pulling straight up from the base enclosure **(4)**.

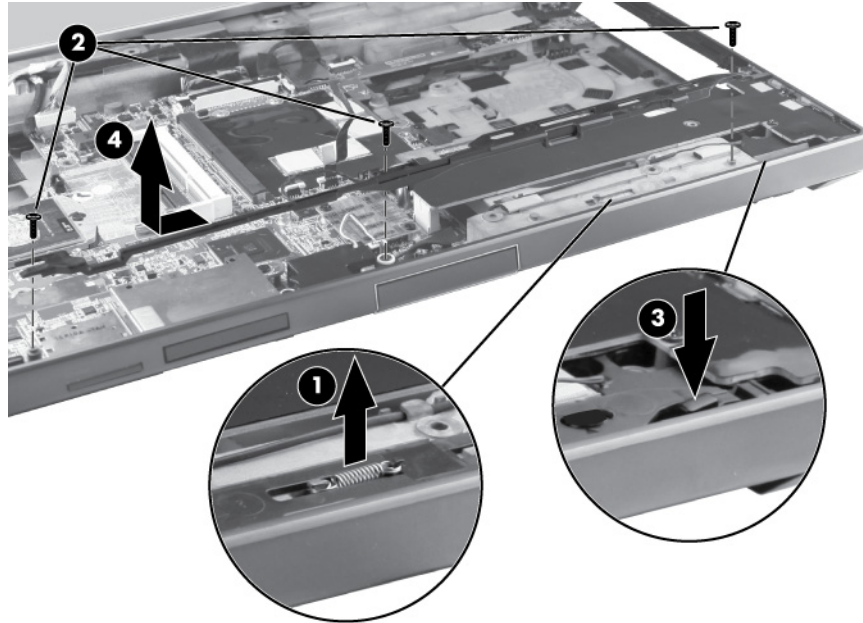

3. Remove the display latch spring buttons:
 - a. In the lower right corner of the base enclosure, remove the two Torx 8 screws **(1)** that secure the display latch spring button to the base enclosure.
 - b. Lift the right display latch spring button **(2)** straight up from the base enclosure.

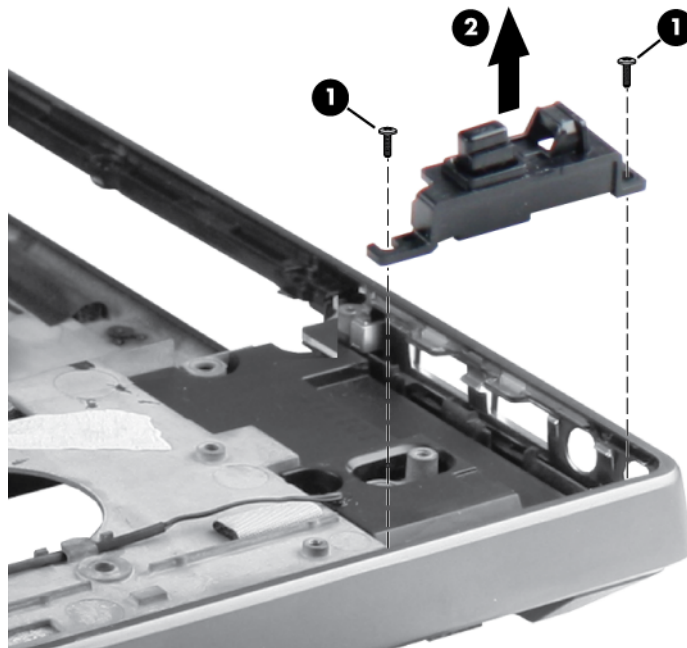

4. Remove the tape **(1)** from the top of the speakers.

5. Disconnect the speaker cable **(2)** from the system board.
6. Remove the four Torx 8 screws **(3)** that secure the speakers to the base enclosure.
7. Remove the speakers **(4)** from the base enclosure.

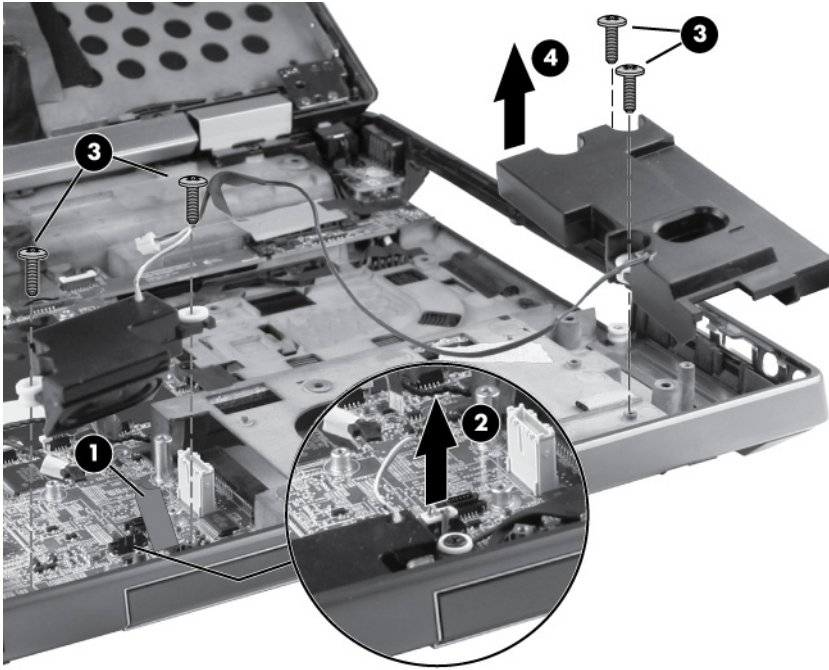

Reverse this procedure to install the speakers.

ExpressCard/USB 2.0 assembly

Description	Spare part number
ExpressCard/USB 2.0 assembly	652680-001

Before removing the ExpressCard/USB 2.0 assembly, follow these steps:



IMPORTANT: Make special note of each screw and screw lock size and location during removal and replacement.

1. Shut down the computer. If you are unsure whether the computer is off or in Hibernation, turn the computer on, and then shut it down through the operating system.
2. Disconnect all external devices connected to the computer.
3. Disconnect the power from the computer by first unplugging the power cord from the AC outlet, and then unplugging the AC adapter from the computer.
4. Remove the battery (see [Battery on page 54](#)).
5. Remove the service door (see [Service door on page 60](#)).
6. Remove the following components:
 - a. Hard drive (see [Hard drive on page 72](#)).
 - b. Upgrade bay device (see [Upgrade bay device on page 77](#)).
 - c. Keyboard (see [Keyboard on page 81](#)).
 - d. Top cover (see [Top cover on page 87](#)).
 - e. Fan and heat sink assembly (see [Fan and heat sink assembly on page 100](#)).
 - f. Processor (see [Processor on page 104](#)).
 - g. Modem module (see [Modem module on page 108](#)).
 - h. Audio/USB 3.0 board (see [Audio/USB 3.0 board on page 106](#)).
 - i. Speakers (see [Speakers on page 110](#)).

Remove the ExpressCard/USB 2.0 assembly:

1. Position the computer right-side up, with the front toward you.
2. Remove the SD and CFast slot protective inserts **(1)**.
3. Remove the three Torx 8 screws **(2)** that secure the assembly to the system board.

4. Lift the assembly up **(3)** and remove the assembly from the base enclosure at a 45 degree angle **(4)**.

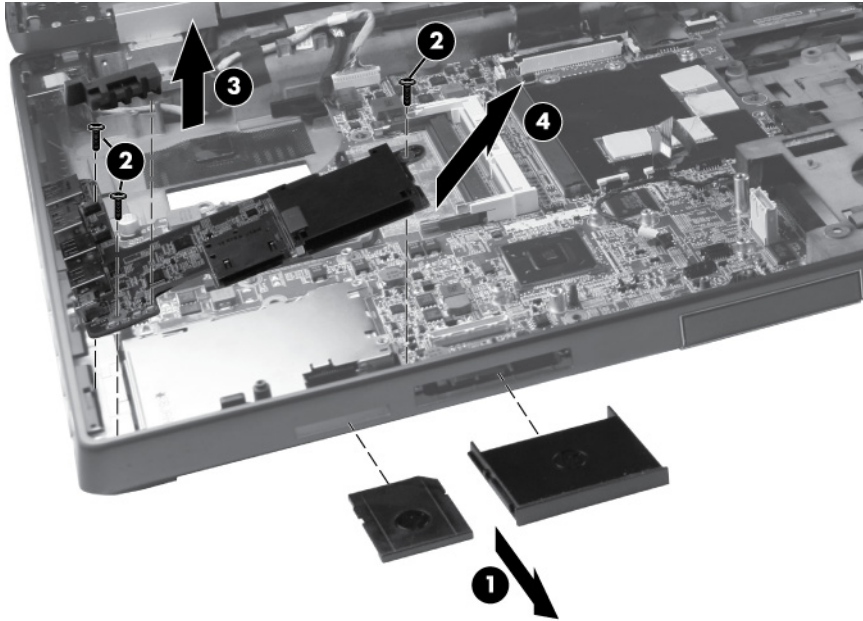

Reverse this procedure to install the ExpressCard/USB 2.0 assembly.

Northbridge chip heat sink

Description	Spare part number
Northbridge chip heat sink	
NOTE: The Northbridge chip heat sink is included with the base enclosure assembly, spare part number 698946-001.	

Before removing the Northbridge chip heat sink, follow these steps:



IMPORTANT: Make special note of each screw and screw lock size and location during removal and replacement.

1. Shut down the computer. If you are unsure whether the computer is off or in Hibernation, turn the computer on, and then shut it down through the operating system.
2. Disconnect all external devices connected to the computer.
3. Disconnect the power from the computer by first unplugging the power cord from the AC outlet, and then unplugging the AC adapter from the computer.
4. Remove the battery (see [Battery on page 54](#)).
5. Remove the service door (see [Service door on page 60](#)).
6. Remove the following components:
 - a. Hard drive (see [Hard drive on page 72](#)).
 - b. Upgrade bay device (see [Upgrade bay device on page 77](#)).
 - c. Keyboard (see [Keyboard on page 81](#)).
 - d. Top cover (see [Top cover on page 87](#)).

Remove the Northbridge chip heat sink:

1. Position the computer right-side up, with the front toward you.
2. Remove the two Phillips screws **(1)** that secure the Northbridge chip heat sink to the system board.

3. Remove the Northbridge chip heat sink from the system board **(2)**.

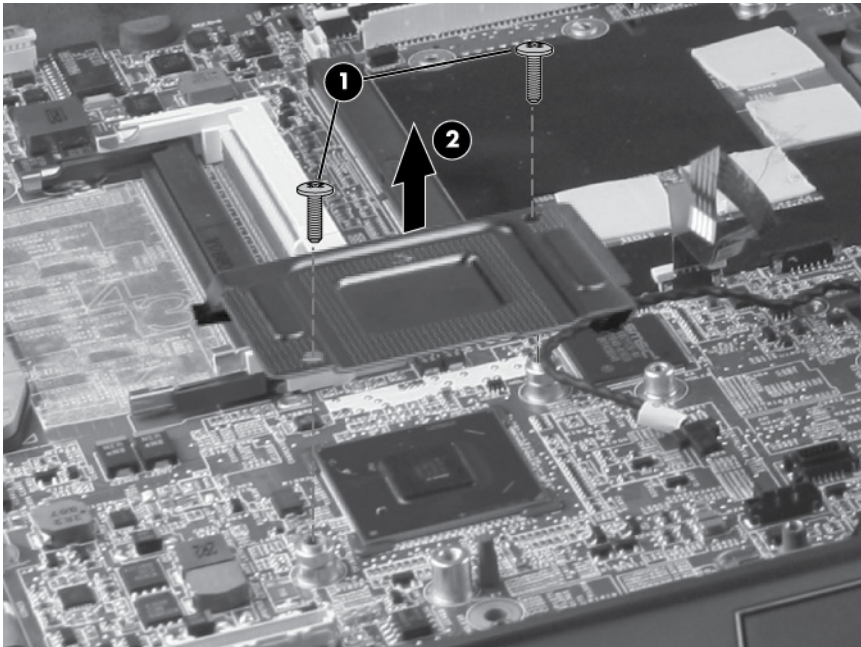

Reverse this procedure to install the Northbridge chip heat sink.

System board

 **NOTE:** All system board spare part kits include replacement thermal material and VGA support bracket.

 **NOTE:** Models that support quad-core processors have four memory slots. Models that support dual-core processors have two memory slots.

Description	Spare part number
For use with quad-core processors and the Windows 8 Professional operating system in all countries except China and Russia	690643-601
For use with quad-core processors and the Windows 8 Standard operating system in all countries except China and Russia	690643-501
For use with quad-core processors and the Windows 7 operating system in all countries except China and Russia	690643-001
For use with quad-core processors in China and Russia only	696441-001
For use with dual-core processors and the Windows 8 Professional operating system in all countries except China and Russia	690642-601
For use with dual-core processors and the Windows 8 Standard operating system in all countries except China and Russia	690642-501
For use with dual-core processors and the Windows 7 operating system in all countries except China and Russia	690642-001
For use with dual-core processors in China and Russia only	696440-001

Before removing the system board, follow these steps:

 **IMPORTANT:** Make special note of each screw and screw lock size and location during removal and replacement.

1. Shut down the computer. If you are unsure whether the computer is off or in Hibernation, turn the computer on, and then shut it down through the operating system.
2. Disconnect all external devices connected to the computer.
3. Disconnect the power from the computer by first unplugging the power cord from the AC outlet, and then unplugging the AC adapter from the computer.
4. Remove the battery (see [Battery on page 54](#)).
5. Remove the service door (see [Service door on page 60](#)).
6. Remove the following components:
 - a. Hard drive (see [Hard drive on page 72](#)).
 - b. Upgrade bay device (see [Upgrade bay device on page 77](#)).
 - c. Keyboard (see [Keyboard on page 81](#)).

- d. Top cover (see [Top cover on page 87](#)).
- e. Fan and heat sink assembly (see [Fan and heat sink assembly on page 100](#)).
- f. Audio/USB 3.0 board (see [Audio/USB 3.0 board on page 106](#)).
- g. Speakers (see [Speakers on page 110](#)).
- h. ExpressCard/USB 2.0 assembly (see [ExpressCard/USB 2.0 assembly on page 113](#)).

When replacing the system board, be sure that the following components are removed from the defective system board and installed on the replacement system board:

- Memory modules (see [Memory Modules \(under service door\) on page 62](#))
- WLAN module (see [WLAN module on page 65](#))
- WWAN module (see [WWAN module on page 68](#))
- Modem module (see [Modem module on page 108](#))
- Processor (see [Processor on page 104](#))
- Graphics card (see [Graphics card on page 102](#))
- Northbridge chip heat sink (see [Northbridge chip heat sink on page 115](#))

Remove the system board:

1. Position the computer right-side up, with the front toward you.
2. Remove the tape **(1)** that secures the cabling to the system board.
3. Remove the screws **(2)** that secure the plastic bracket to the system board, and then remove the bracket **(3)**.

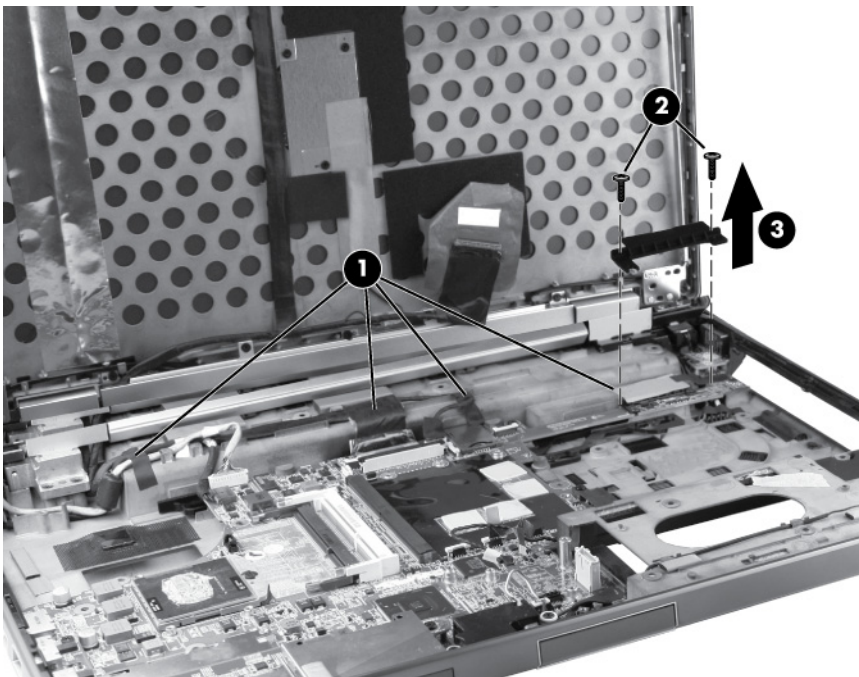

4. Disconnect the power jack **(1)**, the network cable **(2)**, the display cable **(3)**, and the webcam cable **(4)**.

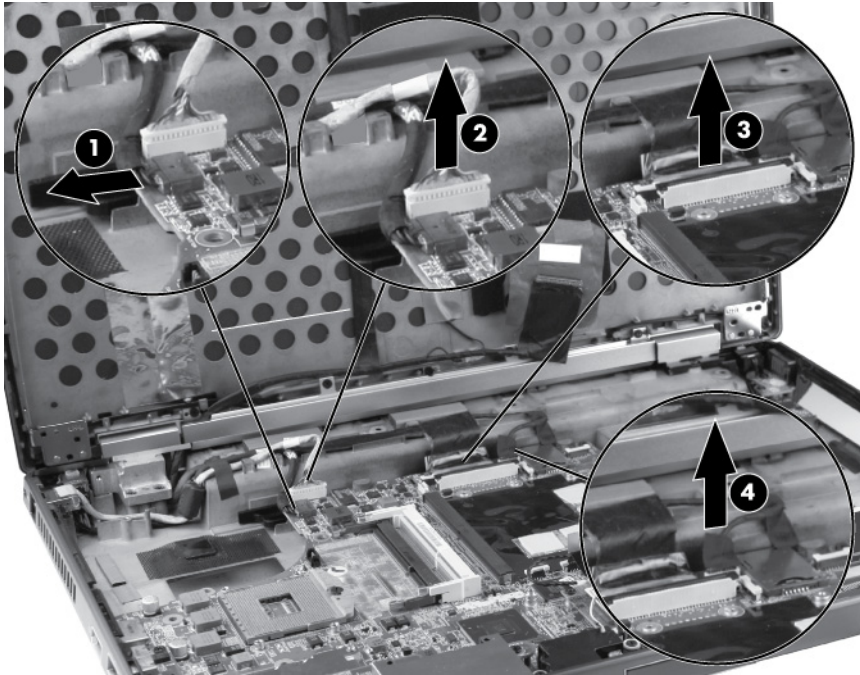

5. Remove the Phillips screw **(1)** that secures the smart card reader to the system board.
6. Remove the three Torx 8 screws **(2)** that secure the system board to the base enclosure.
7. Remove the two Torx 8 screws **(3)** that secure the system board to the optical drive connector.
8. Remove the system board **(4)** from the base enclosure.

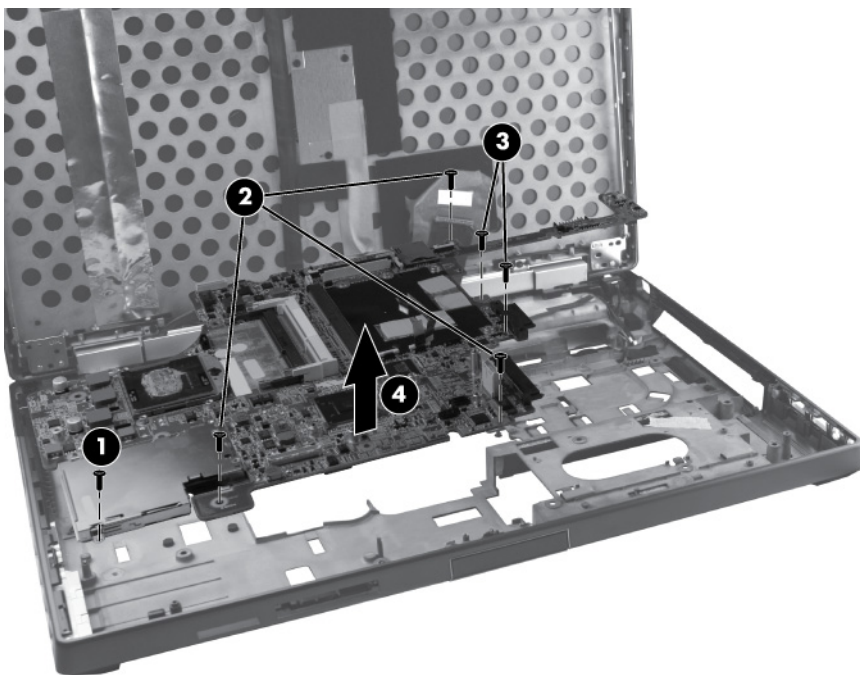

Reverse this procedure to install the system board.

RJ-45 connector cable

 **NOTE:** The RJ-45 connector cable is included in the cable kit, spare part number 690623-001.

Before removing the RJ-45 connector cable, follow these steps:

 **IMPORTANT:** Make special note of each screw and screw lock size and location during removal and replacement.

1. Shut down the computer. If you are unsure whether the computer is off or in Hibernation, turn the computer on, and then shut it down through the operating system.
2. Disconnect all external devices connected to the computer.
3. Disconnect the power from the computer by first unplugging the power cord from the AC outlet, and then unplugging the AC adapter from the computer.
4. Remove the battery (see [Battery on page 54](#)).
5. Remove the service door (see [Service door on page 60](#)).
6. Remove the following components:
 - a. Hard drive (see [Hard drive on page 72](#)).
 - b. Upgrade bay device (see [Upgrade bay device on page 77](#)).
 - c. Keyboard (see [Keyboard on page 81](#)).
 - d. Top cover (see [Top cover on page 87](#)).
 - e. Fan and heat sink assembly (see [Fan and heat sink assembly on page 100](#)).
 - f. Audio/USB 3.0 board (see [Audio/USB 3.0 board on page 106](#)).
 - g. Speakers (see [Speakers on page 110](#)).
 - h. ExpressCard/USB 2.0 assembly (see [ExpressCard/USB 2.0 assembly on page 113](#)).
 - i. System board (see [System board on page 117](#)).

Remove the RJ-45 connector cable:

1. Position the computer right-side up, with the front toward you.
2. Remove the tape **(1)** from the top of the RJ-45 connector cable.
3. Remove the RJ-45 connector cable from the clips and routing channel **(2)** built into the base enclosure.

4. Remove the RJ-45 connector cable from the base enclosure **(3)**.

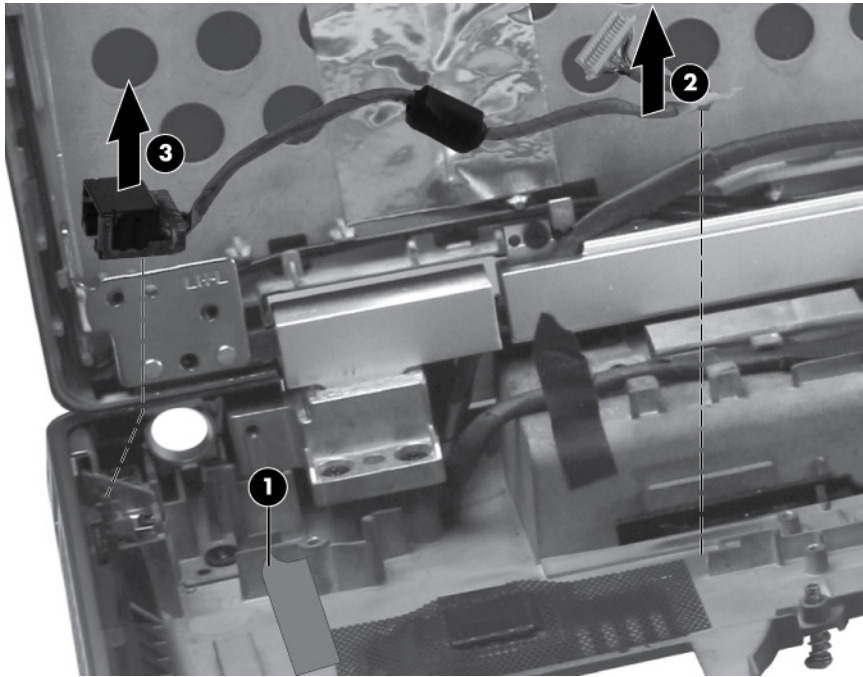

Reverse this procedure to install the RJ-45 connector cable.

Power connector cable

 **NOTE:** The power connector cable is included in the cable kit, spare part number 690623-001.

Before removing the power connector cable, follow these steps:

 **IMPORTANT:** Make special note of each screw and screw lock size and location during removal and replacement.

1. Shut down the computer. If you are unsure whether the computer is off or in Hibernation, turn the computer on, and then shut it down through the operating system.
2. Disconnect all external devices connected to the computer.
3. Disconnect the power from the computer by first unplugging the power cord from the AC outlet, and then unplugging the AC adapter from the computer.
4. Remove the battery (see [Battery on page 54](#)).
5. Remove the service door (see [Service door on page 60](#)).
6. Remove the following components:
 - a. Hard drive (see [Hard drive on page 72](#)).
 - b. Upgrade bay device (see [Upgrade bay device on page 77](#)).
 - c. Keyboard (see [Keyboard on page 81](#)).
 - d. Top cover (see [Top cover on page 87](#)).
 - e. Fan and heat sink assembly (see [Fan and heat sink assembly on page 100](#)).
 - f. Audio/USB 3.0 board (see [Audio/USB 3.0 board on page 106](#)).
 - g. Speakers (see [Speakers on page 110](#)).
 - h. ExpressCard/USB 2.0 assembly (see [ExpressCard/USB 2.0 assembly on page 113](#)).
 - i. System board (see [System board on page 117](#)).

Remove the power connector cable:

1. Position the computer right-side up, with the front toward you.
2. Remove the tape **(1)** from the top of the power connector cable.
3. Lift the power connector cable **(2)** up from the routing in the rear of the base enclosure.

4. Remove the power connector cable from the enclosure **(3)**.

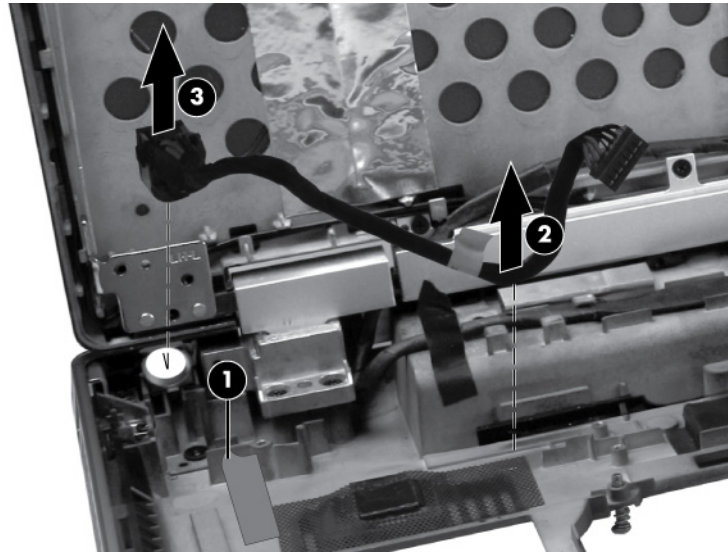

Reverse this procedure to install the power connector cable.

RJ-11 connector cable

 **NOTE:** The RJ-11 connector cable is included in the cable kit, spare part number 690623-001.

Before removing the RJ-11 connector cable, follow these steps:

 **IMPORTANT:** Make special note of each screw and screw lock size and location during removal and replacement.

1. Shut down the computer. If you are unsure whether the computer is off or in Hibernation, turn the computer on, and then shut it down through the operating system.
2. Disconnect all external devices connected to the computer.
3. Disconnect the power from the computer by first unplugging the power cord from the AC outlet, and then unplugging the AC adapter from the computer.
4. Remove the battery (see [Battery on page 54](#)).
5. Remove the service door (see [Service door on page 60](#)).
6. Remove the following components:
 - a. Hard drive (see [Hard drive on page 72](#)).
 - b. Upgrade bay device (see [Upgrade bay device on page 77](#)).
 - c. Keyboard (see [Keyboard on page 81](#)).
 - d. Top cover (see [Top cover on page 87](#)).
 - e. Fan and heat sink assembly (see [Fan and heat sink assembly on page 100](#)).
 - f. Audio/USB 3.0 board (see [Audio/USB 3.0 board on page 106](#)).
 - g. Speakers (see [Speakers on page 110](#)).
 - h. ExpressCard/USB 2.0 assembly (see [ExpressCard/USB 2.0 assembly on page 113](#)).
 - i. System board (see [System board on page 117](#)).

Remove the RJ-11 connector cable:

1. Position the computer right-side up, with the front toward you.

2. Remove the RJ-11 connector cable from the clips and routing channel built into the base enclosure.

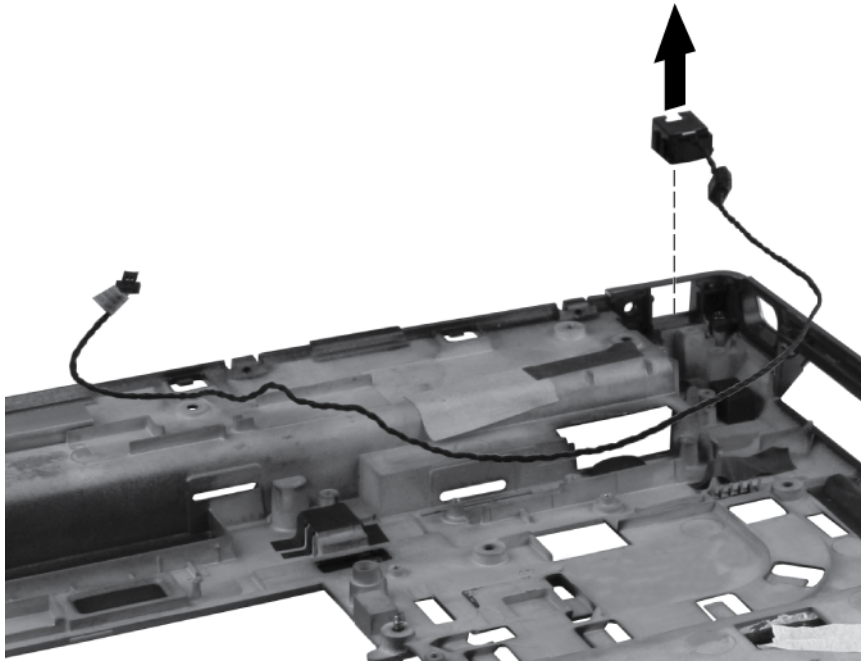

3. Remove the RJ-11 connector cable from the base enclosure.

Reverse this procedure to install the RJ-11 connector cable.

Service door latch

 **NOTE:** The service door latch is included with the battery latch kit , spare part number 690633-001.

Before removing the service door latch, follow these steps:

 **IMPORTANT:** Make special note of each screw and screw lock size and location during removal and replacement.

1. Shut down the computer. If you are unsure whether the computer is off or in Hibernation, turn the computer on, and then shut it down through the operating system.
2. Disconnect all external devices connected to the computer.
3. Disconnect the power from the computer by first unplugging the power cord from the AC outlet, and then unplugging the AC adapter from the computer.
4. Remove the battery (see [Battery on page 54](#)).
5. Remove the service door (see [Service door on page 60](#)).
6. Remove the following components:
 - a. Hard drive (see [Hard drive on page 72](#)).
 - b. Upgrade bay device (see [Upgrade bay device on page 77](#)).
 - c. Keyboard (see [Keyboard on page 81](#)).
 - d. Top cover (see [Top cover on page 87](#)).
 - e. Fan and heat sink assembly (see [Fan and heat sink assembly on page 100](#)).
 - f. Audio/USB 3.0 board (see [Audio/USB 3.0 board on page 106](#)).
 - g. Speakers (see [Speakers on page 110](#)).
 - h. ExpressCard/USB 2.0 assembly (see [ExpressCard/USB 2.0 assembly on page 113](#)).
 - i. System board (see [System board on page 117](#)).
 - j. RJ-11 connector cable (see [RJ-11 connector cable on page 124](#)).

Remove the service door latch:

1. Position the computer right-side up with the front toward you.
2. Remove the three Phillips screws **(1)** that secure the service door latch to the base enclosure.

3. Remove the service door latch from the base enclosure **(2)**, ensuring that the spring **(3)** remains intact with the service door latch.

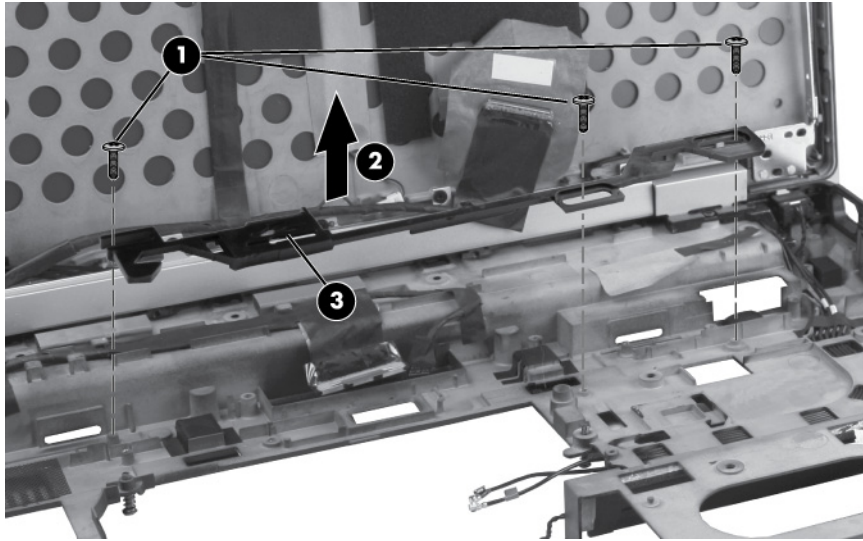

Reverse this procedure to install the service door latch.

Battery latch

 **NOTE:** The battery latch is included with the battery latch kit , spare part number 690633-001.

Before removing the battery latch, follow these steps:

 **IMPORTANT:** Make special note of each screw and screw lock size and location during removal and replacement.

1. Shut down the computer. If you are unsure whether the computer is off or in Hibernation, turn the computer on, and then shut it down through the operating system.
2. Disconnect all external devices connected to the computer.
3. Disconnect the power from the computer by first unplugging the power cord from the AC outlet, and then unplugging the AC adapter from the computer.
4. Remove the battery (see [Battery on page 54](#)).
5. Remove the service door (see [Service door on page 60](#)).
6. Remove the following components:
 - a. Hard drive (see [Hard drive on page 72](#)).
 - b. Upgrade bay device (see [Upgrade bay device on page 77](#)).
 - c. Keyboard (see [Keyboard on page 81](#)).
 - d. Top cover (see [Top cover on page 87](#)).
 - e. Fan and heat sink assembly (see [Fan and heat sink assembly on page 100](#)).
 - f. Audio/USB 3.0 board (see [Audio/USB 3.0 board on page 106](#)).
 - g. Speakers (see [Speakers on page 110](#)).
 - h. ExpressCard/USB 2.0 assembly (see [ExpressCard/USB 2.0 assembly on page 113](#)).
 - i. System board (see [System board on page 117](#)).
 - j. RJ-11 connector cable (see [RJ-11 connector cable on page 124](#)).
 - k. Service door latch (see [Service door latch on page 126](#)).

Remove the battery latch:

1. Position the computer right-side up with the front toward you.

 **CAUTION:** Ensure that the spring **(1)** remains intact while removing the battery latch.

2. Remove the two Phillips screws **(2)** that secure the battery latch to the base enclosure.

3. Remove the battery latch from the base enclosure **(3)**.

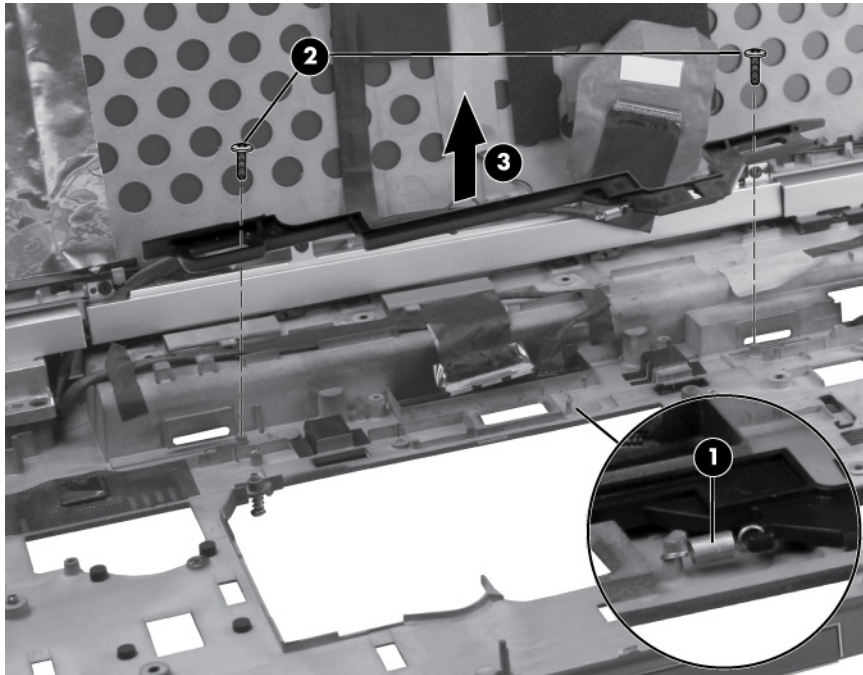

Reverse this procedure to install the battery latch.

Display assembly

Description	Spare part number
39.6-cm (15.6 in) FHD RGB UWVA LCD display assembly with DreamColor:	
For use in computer models without webcams	690627-001
For use in computer models with webcams	690626-001

 **NOTE:** It is not necessary to remove the display panel in order to remove the display assembly. However, for access to the webcam module, WLAN module, or WWAN module, you must remove the display panel. For display panel removal instructions, see [Display panel \(non-DreamColor\) on page 55](#)

Before removing the display assembly, follow these steps:

 **IMPORTANT:** Make special note of each screw and screw lock size and location during removal and replacement.

1. Shut down the computer. If you are unsure whether the computer is off or in Hibernation, turn the computer on, and then shut it down through the operating system.
2. Disconnect all external devices connected to the computer.
3. Disconnect the power from the computer by first unplugging the power cord from the AC outlet, and then unplugging the AC adapter from the computer.
4. Remove the battery (see [Battery on page 54](#)).
5. (Optional) Remove the display panel (see [Display panel \(non-DreamColor\) on page 55](#))
6. Remove the service door (see [Service door on page 60](#))
7. Disconnect the wireless antenna cables from the WLAN module (see [WLAN module on page 65](#)) and the WWAN module (see [WWAN module on page 68](#)).
8. Remove the following components:
 - a. Hard drive (see [Hard drive on page 72](#)).
 - b. Upgrade bay device (see [Upgrade bay device on page 77](#)).
 - c. Keyboard (see [Keyboard on page 81](#)).
 - d. Top cover (see [Top cover on page 87](#)).

Remove the display assembly:

1. Position the computer right side up, with the display closed and the rear toward you.
2. Remove the four Torx T8M2.5×4.5 screws **(1)** that secure the display hinge cover to the base enclosure.

3. Lift the display hinge cover **(2)** straight up and remove it.

The display hinge cover is available using spare part number 652657-001.

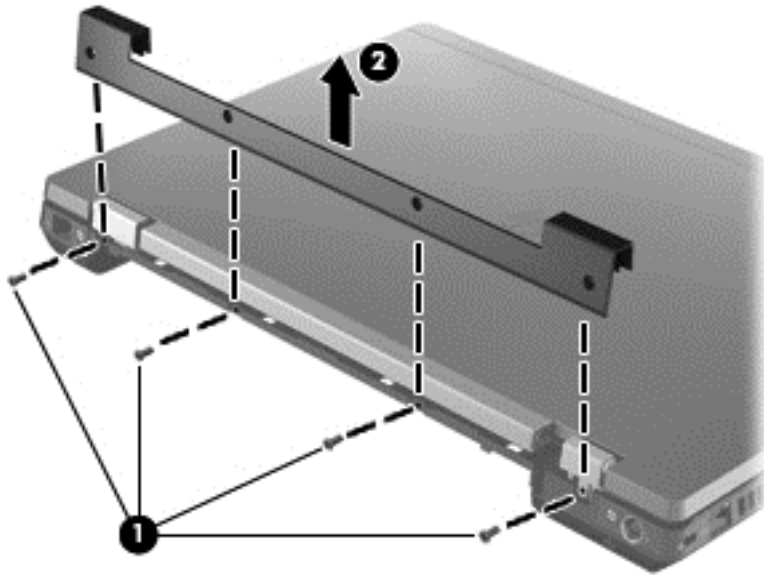

4. Remove the two Torx T8M2.5x4.5 screws that secure the display assembly to the computer.



5. Position the computer upside down, with the front toward you.

6. Remove the WLAN and WWAN antenna cables **(1)** from the routing tabs **(2)** in the base enclosure.

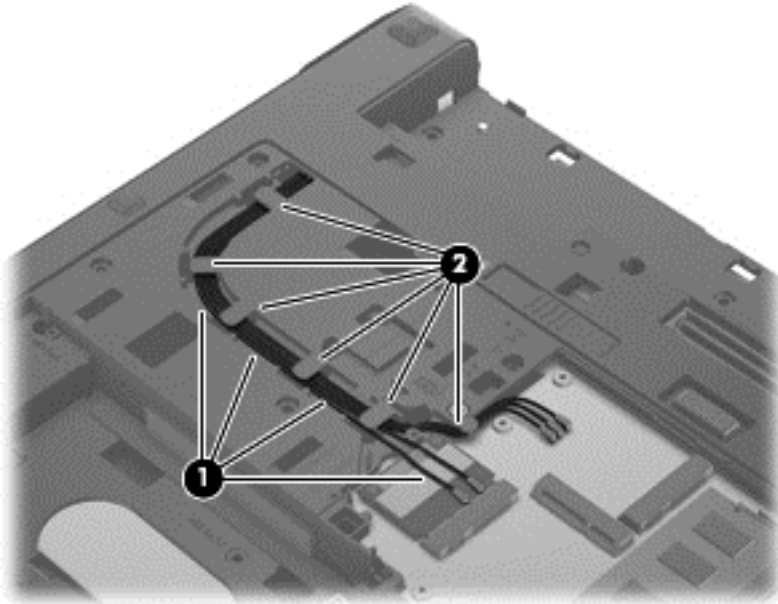

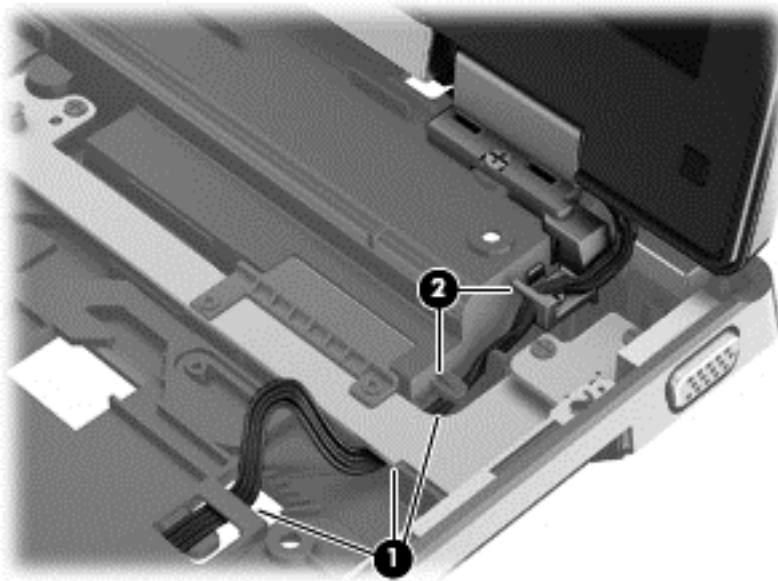

7. Thread the WLAN and WWAN antenna cables **(1)** through the hole and then back up underneath the system board, unhook the antenna cables from the retaining tabs **(2)**.

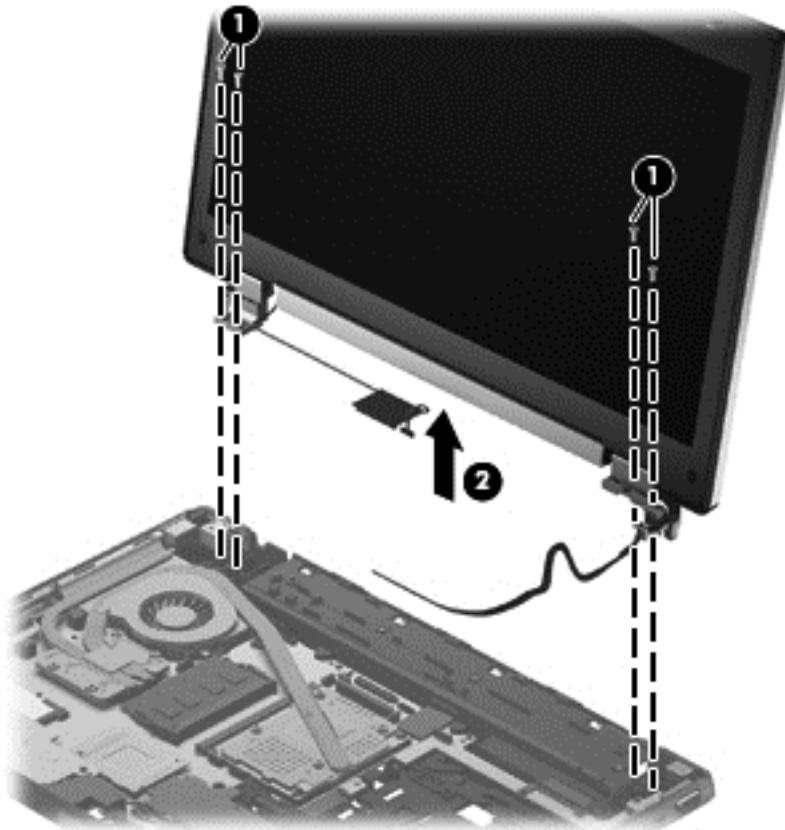

8. Remove the four Torx 8 screws **(1)** from the brackets.
9. Lift the display cable connector **(2)** straight up from the system board and carefully release the display cable from the cable routing slots in the base enclosure.

10. Lift the display assembly straight up from the base enclosure and remove it.



 **NOTE:** For a hinge-up display assembly replacement, reverse these procedures to reinstall the display assembly.

11. Remove the display bezel:
 - a. Remove the two rubber pads **(1)** that cover the display panel screws.

- b.** Remove the two Torx 8 screws **(2)** that secure the display bezel to the display enclosure.

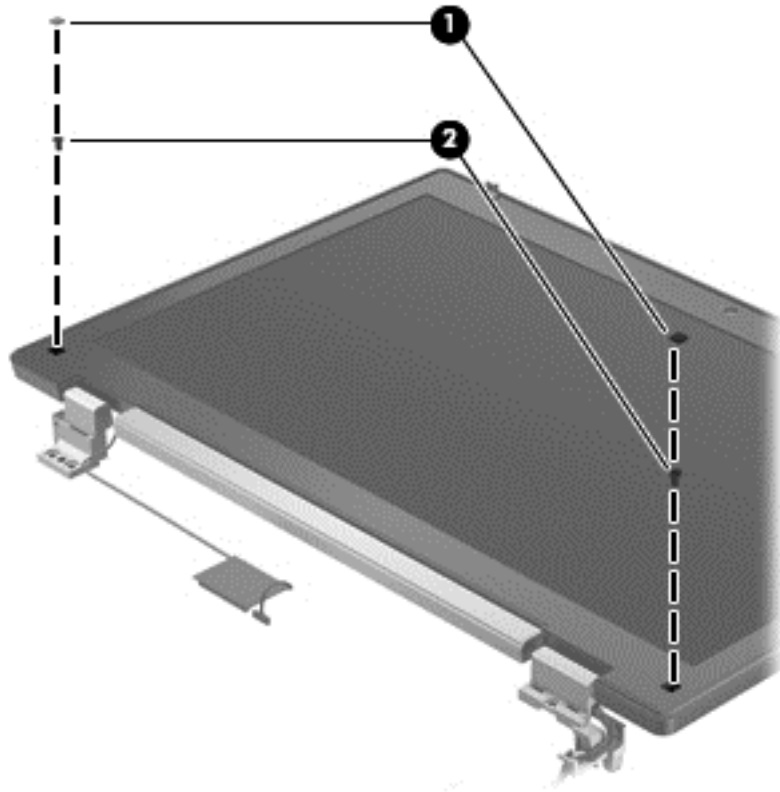

- c.** Flex the top **(1)** of the bezel from the inside edge until it disengages from the display back cover.
- d.** Flex the inside edge of the left side and the right side **(2)** of the bezel until it disengages from the display back cover.
- e.** Flex the bottom **(3)** of the bezel from the inside edge until it disengages from the display back cover.

- f. Remove the display bezel from the display back cover **(4)**.

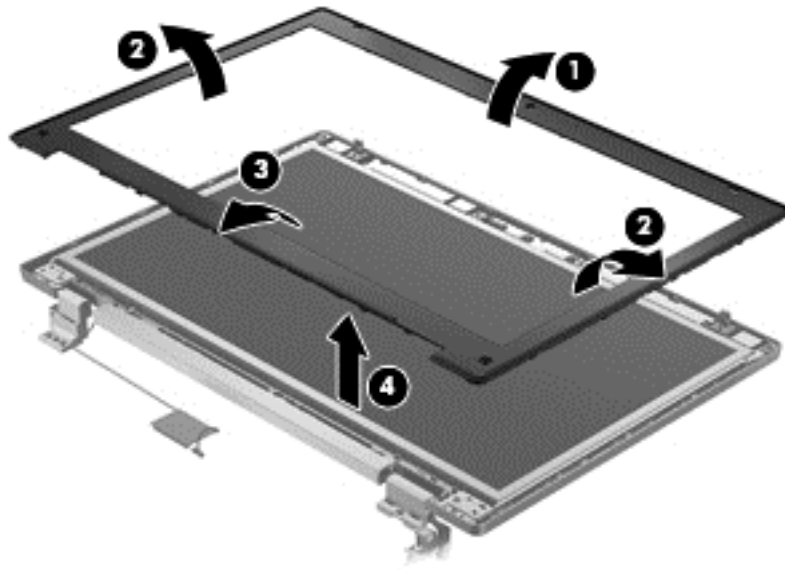

g.

- 12.** If it is necessary to remove the cable routing tray, remove the three Phillips screws **(1)** that secure the cable routing tray to the display enclosure, then pull the cable routing tray towards you **(2)**. The cable routing tray is available in the Plastics kit, spare part number 684794-001.

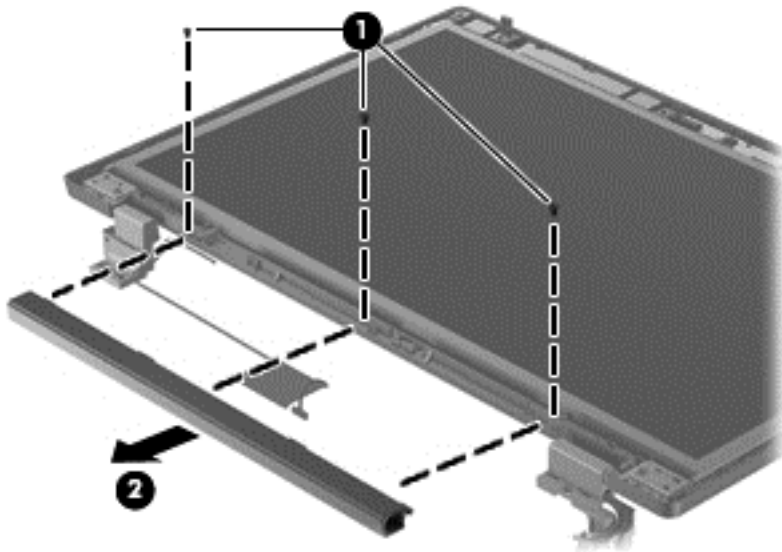

- 13.** Remove the six Torx 8 screws that secure the display panel to the display enclosure.

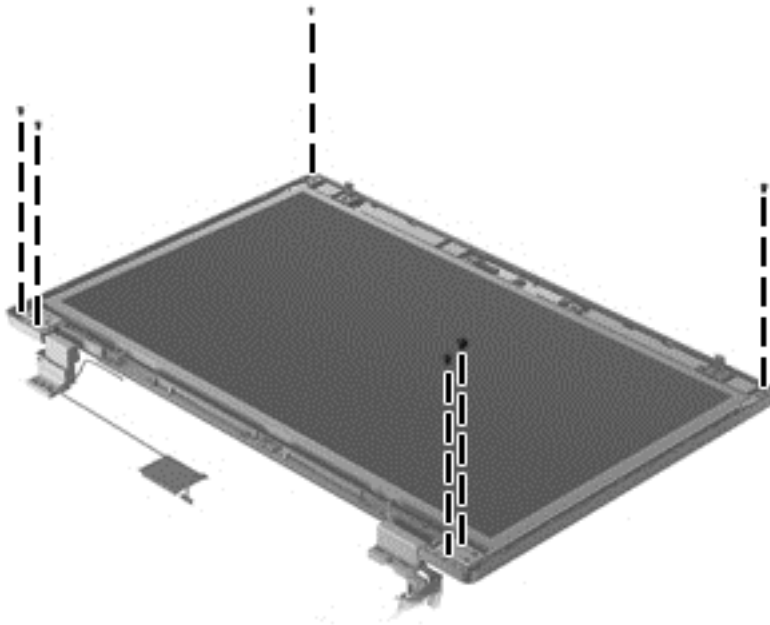

- 14.** If it is necessary to replace the display hinges, Remove the eight Phillips screws (1) that secure the display panel to the display hinges (four on either side). The left and right display hinges are available using spare part number 652646-001.
- a.** Remove the eight Phillips screws (1) that secure the display panel to the display hinges (four on either side).
 - b.** Remove the display hinges (2).

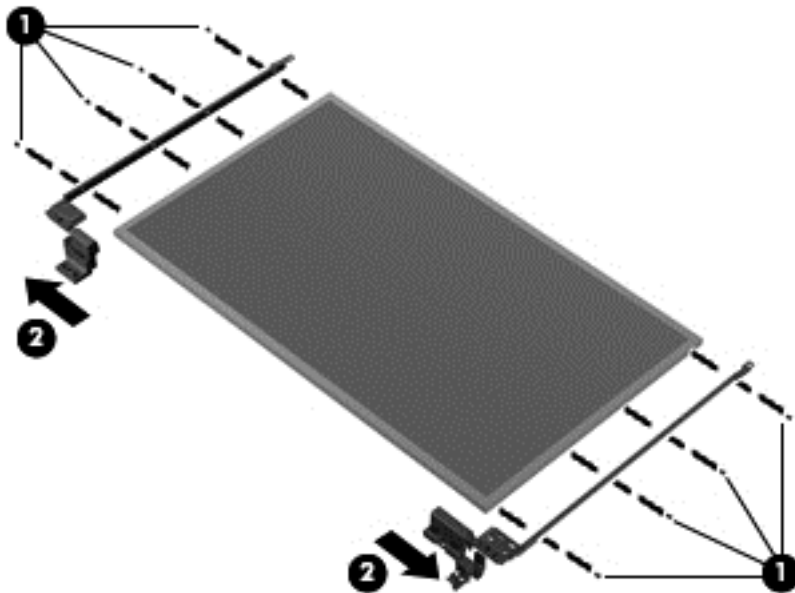

- 15.** If it is necessary to replace the webcam module from the display enclosure, lift the webcam module straight up **(1)**, then pull the connector for the webcam cable and disconnect the cable **(2)**.

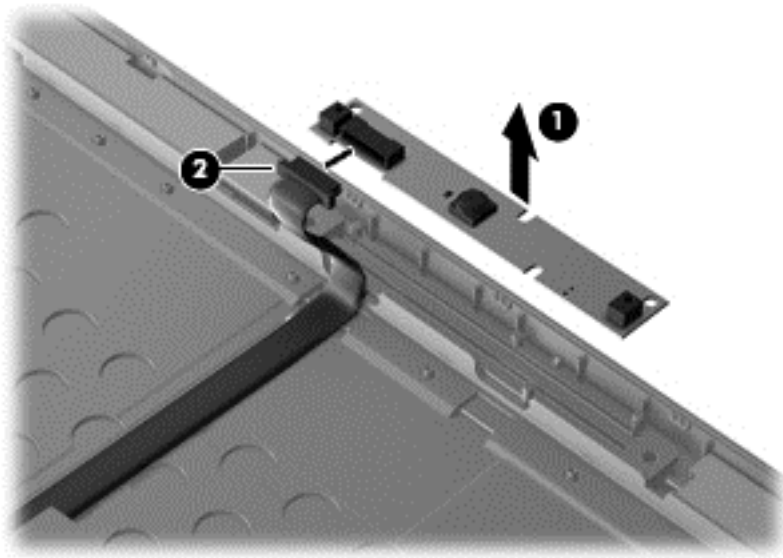

- 16.** If it is necessary to replace the webcam cable, release the tape securing the cable to the display cover **(1)**, and then remove the cable **(2)**.

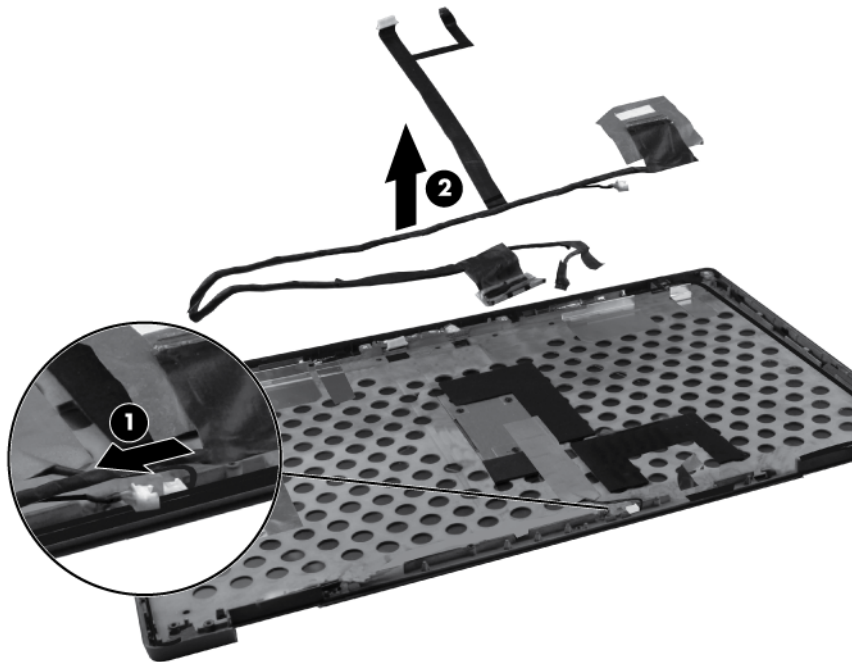

17. If it is necessary to replace the WWAN antenna cables, detach the WWAN antenna transceivers **(1)** from the adhesive on the back cover, and then release the cables from the clips **(2)** that secure the cables to the display back cover.

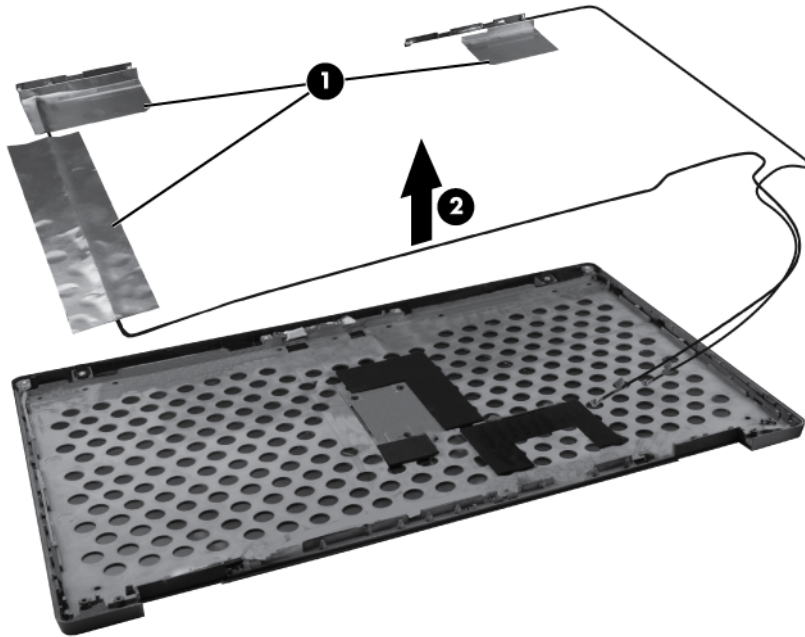

18. If it is necessary to replace the WLAN antenna cables, detach the WLAN antenna transceivers **(1)** from the adhesive on the back cover, and then release the cables from the clips **(2)** that secure the cables to the display back cover.

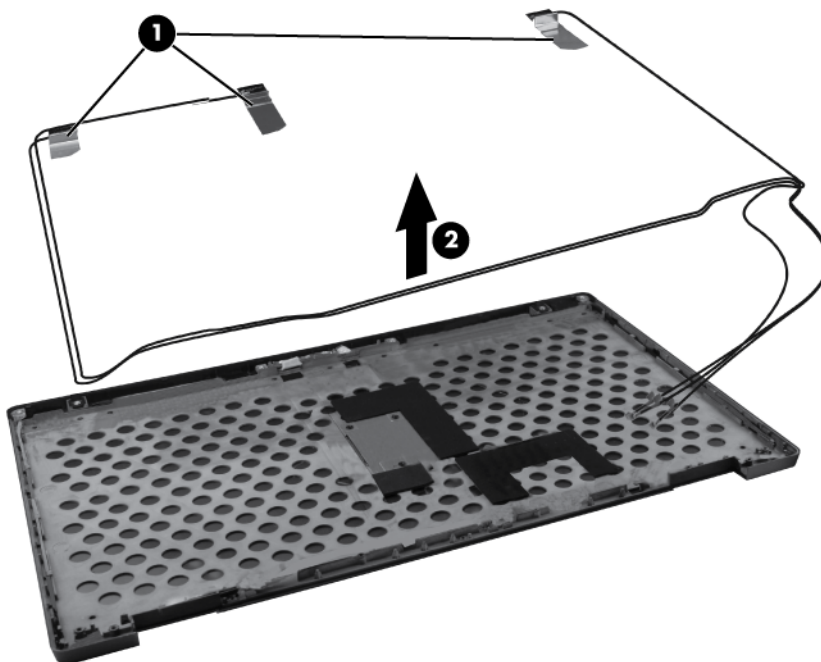

Reverse this procedure to reassemble and install the display assembly.

5 Computer Setup

Windows 8

Using Computer Setup

Computer Setup, or Basic Input/Output System (BIOS), controls communication between all the input and output devices on the system (such as disk drives, display, keyboard, mouse, and printer). Computer Setup includes settings for the types of devices installed, the startup sequence of the computer, and the amount of system and extended memory.

 **NOTE:** Use extreme care when making changes in Computer Setup. Errors can prevent the computer from operating properly.

Starting Computer Setup

 **NOTE:** An external keyboard or mouse connected to a USB port can be used with Computer Setup only if USB legacy support is enabled.

To start Computer Setup, follow these steps:

1. Turn on or restart the computer, and then press **esc** while the “Press the ESC key for Startup Menu” message is displayed at the bottom of the screen.
2. Press **f10** to enter Computer Setup.

Navigating and selecting in Computer Setup

To navigate and select in Computer Setup, follow these steps:

1. Turn on or restart the computer, and then press **esc** while the “Press the ESC key for Startup Menu” message is displayed at the bottom of the screen.
 - To select a menu or a menu item, use the **tab** key and the keyboard arrow keys and then press **enter**, or use a pointing device to click the item.
 - To scroll up and down, click the up arrow or the down arrow in the upper-right corner of the screen, or use the up arrow key or the down arrow key.
 - To close open dialog boxes and return to the main Computer Setup screen, press **esc**, and then follow the on-screen instructions.

 **NOTE:** You can use either a pointing device (TouchPad, pointing stick, or USB mouse) or the keyboard to navigate and make selections in Computer Setup.

2. Press **f10** to enter Computer Setup.

To exit Computer Setup menus, choose one of the following methods:

- To exit Computer Setup menus without saving your changes:

Click the **Exit** icon in the lower-left corner of the screen, and then follow the on-screen instructions.

– or –

Use the **tab** key and the arrow keys to select **File > Ignore Changes and Exit**, and then press **enter**.

- To save your changes and exit Computer Setup menus:

Click the **Save** icon in the lower-left corner of the screen, and then follow the on-screen instructions.

– or –

Use the **tab** key and the arrow keys to select **File > Save Changes and Exit**, and then press **enter**.

Your changes go into effect when the computer restarts.

Restoring factory settings in Computer Setup

 **NOTE:** Restoring defaults will not change the hard drive mode.

To return all settings in Computer Setup to the values that were set at the factory, follow these steps:

1. Turn on or restart the computer, and then press **esc** while the “Press the ESC key for Startup Menu” message is displayed at the bottom of the screen.
2. Press **f10** to enter Computer Setup.
3. Use a pointing device or the arrow keys to select **File > Restore Defaults**.
4. Follow the on-screen instructions.
5. To save your changes and exit, click the **Save** icon in the lower-left corner of the screen, and then follow the on-screen instructions.

– or –

Use the arrow keys to select **File > Save Changes and Exit**, and then press **enter**.

Your changes go into effect when the computer restarts.

 **NOTE:** Your password settings and security settings are not changed when you restore the factory settings.

Updating the BIOS

Updated versions of the BIOS may be available on the HP website.

Most BIOS updates on the HP website are packaged in compressed files called *SoftPaqs*.

Some download packages contain a file named *Readme.txt*, which contains information regarding installing and troubleshooting the file.

Determining the BIOS version

To determine whether available BIOS updates contain later BIOS versions than those currently installed on the computer, you need to know the version of the system BIOS currently installed.

BIOS version information (also known as *ROM date* and *System BIOS*) can be displayed by pressing **fn + esc** (if you are already in Windows) or by using Computer Setup.

1. Start Computer Setup.
2. Use a pointing device or the arrow keys to select **File > System Information**.
3. To exit Computer Setup without saving your changes, click the Exit icon in the lower-left corner of the screen, and then follow the on-screen instructions.

– or –

Use the **tab** key and the arrow keys to select **File > Ignore Changes and Exit**, and then press **enter**.

Downloading a BIOS update

 **CAUTION:** To reduce the risk of damage to the computer or an unsuccessful installation, download and install a BIOS update only when the computer is connected to reliable external power using the AC adapter. Do not download or install a BIOS update while the computer is running on battery power, docked in an optional docking device, or connected to an optional power source. During the download and installation, follow these instructions:

Do not disconnect power on the computer by unplugging the power cord from the AC outlet.

Do not shut down the computer or initiate Sleep.

Do not insert, remove, connect, or disconnect any device, cable, or cord.

1. From the Start screen, type `h`, and then select **Help and Support**.
2. In the **Help and Support** search box, type `maintain`, and then follow the on-screen instructions to identify your computer and access the BIOS update you want to download.
3. At the download area, follow these steps:
 - a. Identify the BIOS update that is later than the BIOS version currently installed on your computer. Make a note of the date, name, or other identifier. You may need this information to locate the update later, after it has been downloaded to your hard drive.
 - b. Follow the on-screen instructions to download your selection to the hard drive.

Make a note of the path to the location on your hard drive where the BIOS update is downloaded. You will need to access this path when you are ready to install the update.

 **NOTE:** If you connect your computer to a network, consult the network administrator before installing any software updates, especially system BIOS updates.

BIOS installation procedures vary. Follow any instructions that are displayed on the screen after the download is complete. If no instructions are displayed, follow these steps:

1. From the Start screen, type `e`, and then click **File Explorer**.
2. Double-click your hard drive designation. The hard drive designation is typically Local Disk (C:).
3. Using the hard drive path you recorded earlier, open the folder on your hard drive that contains the update.
4. Double-click the file that has an `.exe` extension (for example, `filename.exe`).

The BIOS installation begins.

5. Complete the installation by following the on-screen instructions.

 **NOTE:** After a message on the screen reports a successful installation, you can delete the downloaded file from your hard drive.

Using Advanced System Diagnostics

Advanced System Diagnostics allows you to run diagnostic tests to determine if the computer hardware is functioning properly. The following diagnostic tests are available in Advanced System Diagnostics:

- **System Tune-Up**—This group of additional tests checks your computer to make sure that the main components are functioning correctly. System Tune-Up runs longer and more comprehensive tests on memory modules, hard drive SMART attributes, the hard drive surface, the battery (and battery calibration), video memory, and the WLAN module status.
- **Start-up test**—This test analyzes the main computer components that are required to start the computer.
- **Run-in test**—This test repeats the start-up test and checks for intermittent problems that the start-up test does not detect.
- **Hard disk test**—This test analyzes the physical condition of the hard drive, and then checks all data in every sector of the hard drive. If the test detects a damaged sector, it attempts to move the data to a good sector.
- **Memory test**—This test analyzes the physical condition of the memory modules. If it reports an error, replace the memory modules immediately.
- **Battery test**—This test analyzes the condition of the battery and calibrates the battery if necessary. If the battery fails the test, contact HP support to report the issue and purchase a replacement battery.
- **BIOS Management**—You can update or rollback the version of the BIOS on the system. Do not shut down or remove external power during the process. You will be given a confirmation screen before your BIOS is modified. Select **BIOS update**, **BIOS Rollback**, or **Back to main menu**.

You can view system information and error logs or select languages in the Advanced System Diagnostics window.

To start Advanced System Diagnostics:

1. Turn on or restart the computer. While the “Press the ESC key for Startup Menu” message is displayed in the lower-left corner of the screen, press **esc**. When the Startup Menu is displayed, press **f2**.
2. Click the diagnostic test you want to run, and then follow the on-screen instructions.



NOTE: NOTE: you need to stop a diagnostics test while it is running, press **esc**.

Windows 7

Computer Setup, or Basic Input/Output System (BIOS), controls communication between all the input and output devices on the system (such as disk drives, display, keyboard, mouse, and printer). Computer Setup includes settings for the types of peripherals installed, the startup sequence of the computer, and the amount of system and extended memory.

 **NOTE:** Use extreme care when making changes in Computer Setup. Errors can prevent the computer from operating properly.

Starting Computer Setup

 **NOTE:** An external keyboard or mouse connected to a USB port can be used with Computer Setup only if USB legacy support is enabled.

To start Computer Setup, follow these steps:

1. Turn on or restart the computer, and then press **esc** while the “Press the ESC key for Startup Menu” message is displayed at the bottom of the screen.
2. Press **f10** to enter Computer Setup.

Using Computer Setup

Navigating and selecting in Computer Setup

To navigate and select in Computer Setup, follow these steps:

1. Turn on or restart the computer, and then press **esc** while the “Press the ESC key for Startup Menu” message is displayed at the bottom of the screen.
 - To select a menu or a menu item, use the **tab** key and the keyboard arrow keys and then press **enter**, or use a pointing device to click the item.
 - To scroll up and down, click the up arrow or the down arrow in the upper-right corner of the screen, or use the up arrow key or the down arrow key.
 - To close open dialog boxes and return to the main Computer Setup screen, press **esc**, and then follow the on-screen instructions.

 **NOTE:** You can use either a pointing device (TouchPad, pointing stick, or USB mouse) or the keyboard to navigate and make selections in Computer Setup.

2. Press **f10** to enter Computer Setup.

To exit Computer Setup menus, choose one of the following methods:

- To exit Computer Setup menus without saving your changes, click the **Exit** icon in the lower-left corner of the screen, and then follow the on-screen instructions.

– or –

Use the **tab** key and the arrow keys to select **File > Ignore Changes and Exit**, and then press **enter**.
- or –

● To save your changes and exit Computer Setup menus, click the **Save** icon in the lower-left corner of the screen, and then follow the on-screen instructions.

– or –

Use the **tab** key and the arrow keys to select **File > Save Changes and Exit**, and then press **enter**.

Your changes go into effect when the computer restarts.

Restoring factory settings in Computer Setup

 **NOTE:** Restoring defaults will not change the hard drive mode.

To return all settings in Computer Setup to the values that were set at the factory, follow these steps:

1. Turn on or restart the computer, and then press **esc** while the “Press the ESC key for Startup Menu” message is displayed at the bottom of the screen.
2. Press **f10** to enter Computer Setup.
3. Use a pointing device or the arrow keys to select **File > Restore Defaults**.
4. Follow the on-screen instructions.
5. To save your changes and exit, click the **Save** icon in the lower-left corner of the screen, and then follow the on-screen instructions.

– or –

Use the arrow keys to select **File > Save Changes and Exit**, and then press **enter**.

Your changes go into effect when the computer restarts.

 **NOTE:** Your password settings and security settings are not changed when you restore the factory settings.

Updating the BIOS

Updated versions of the BIOS may be available on the HP Web site.

Most BIOS updates on the HP Web site are packaged in compressed files called SoftPaqs.

Some download packages contain a file named Readme.txt, which contains information regarding installing and troubleshooting the file.

Determining the BIOS version

To determine whether available BIOS updates contain later BIOS versions than those currently installed on the computer, you need to know the version of the system BIOS currently installed.

BIOS version information (also known as *ROM date* and *System BIOS*) can be displayed as follows:

1. Start Computer Setup.
2. Use a pointing device or the arrow keys to select **File > System Information**.
3. To exit Computer Setup without saving your changes, click the **Exit** icon in the lower-left corner of the screen, and then follow the on-screen instructions.

– or –

Use the **tab** key and the arrow keys to select **File > Ignore Changes and Exit**, and then press **enter**.



NOTE: You can also determine the BIOS version by turning on or restarting the computer, pressing the **esc** key while the “Press the ESC key for Startup Menu” message is displayed at the bottom of the screen, and then pressing the **f1** key. Follow the on-screen instructions to exit this screen.

Downloading a BIOS update



CAUTION: CAUTION: To reduce the risk of damage to the computer or an unsuccessful installation, download and install a BIOS update only when the computer is connected to reliable external power using the AC adapter. Do not download or install a BIOS update while the computer is running on battery power, docked in an optional docking device, or connected to an optional power source. During the download and installation, follow these instructions:

Do not disconnect power from the computer by unplugging the power cord from the AC outlet.

Do not shut down the computer or initiate Suspend or Hibernation.

Do not insert, remove, connect, or disconnect any device, cable, or cord.

1. Open your Web browser. For U.S. support, go to <http://www.hp.com/go/contactHP>. For worldwide support, go to http://welcome.hp.com/country/us/en/wwcontact_us.html.
2. Follow the on-screen instructions to identify your computer and access the BIOS update you want to download.
3. Click the option for software and driver downloads, type your computer model number in the product box, and then press **enter**. Follow the on-screen instructions to identify your computer and access the BIOS update you want to download.

4. Click your specific product from the models listed.
5. Click the appropriate operating system.
6. Go to the BIOS section and download the BIOS software package.
7. Follow the installation instructions as provided with the downloaded BIOS software package.

 **NOTE:** After a message on the screen reports a successful installation, you can delete the downloaded file from your hard drive.

Using Advanced System Diagnostics

Advanced System Diagnostics allows you to run diagnostic tests to determine if the computer hardware is functioning properly. The following diagnostic tests are available in Advanced System Diagnostics:

- **Start-up test**—This test analyzes the main computer components that are required to start the computer.
- **Run-in test**—This test repeats the start-up test and checks for intermittent problems that the start-up test does not detect.
- **Hard disk test**—This test analyzes the physical condition of the hard drive, and then checks all data in every sector of the hard drive. If the test detects a damaged sector, it attempts to move the data to a good sector.
- **Memory test**—This test analyzes the physical condition of the memory modules. If it reports an error, replace the memory modules immediately.
- **Battery test**—This test analyzes the condition of the battery and calibrates the battery if necessary. If the battery fails the test, contact support to report the issue and purchase a replacement battery.
- **System Tune-Up**—This group of additional tests checks your computer to make sure that the main components are functioning correctly. System Tune-Up runs longer and more comprehensive tests on memory modules, hard drive SMART attributes, the hard drive surface, the battery (and battery calibration), video memory, and the WLAN module status.

You can view system information and error logs in the Advanced System Diagnostics window.

To start Advanced System Diagnostics:

1. Turn on or restart the computer. While the “Press the ESC key for Startup Menu” message is displayed in the lower-left corner of the screen, press **esc**. When the Startup Menu is displayed, press **f2**.
2. Click the diagnostic test you want to run, and then follow the on-screen instructions.

 **NOTE:** If you need to stop a diagnostics test while it is running, press **esc**.

6 Specifications

Computer specifications

	Metric	U.S.
Dimensions		
Length	25.1 cm	9.86 in
Width	37.4 cm	14.72 in
Height (at front)	3.4 cm	1.34 in
Weight (equipped with 39.6-cm (15.6-in) HD+ display, NV Graphics, DVD drive, 1-GB DIMM, 160-GB hard drive, WLAN module, 8-cell battery)	3.1 kg	6.94 lbs
Input power		
Operating voltage	19.5V DC @ 6.15A - 120 W Slim Adapter	
	19.5V DC @ 7.7A - 150 W Slim Adapter	
	19.5V DC @ 10.3A - 200 W Slim Adapter	
Operating current	4.74 A	
Temperature		
Operating	5°C to 35°C	41°F to 95°F
Relative humidity		
Operating	10% to 90%	
Nonoperating	5% to 95%	
Maximum altitude (unpressurized)		
Operating (14.7 to 10.1 psia)	-15 m to 3,048 m	50 ft to 10,000 ft
Nonoperating (14.7 to 4.4 psia)	-15 m to 12,192 m	-50 ft to 40,000 ft
Shock		
Operating	125 g, 2 ms, half-sine	
Nonoperating	200 g, 2 ms, half-sine	
Random vibration		

	Metric	U.S.
Operating	0.75 g zero-to-peak, 10 Hz to 500 Hz, 0.25 oct/min sweep rate	
Nonoperating	1.50 g zero-to-peak, 10 Hz to 500 Hz, 0.5 oct/min sweep rate	

NOTE: Applicable product safety standards specify thermal limits for plastic surfaces. The computer operates well within this range of temperatures.

39.6-cm (15.6-in) HD+ display specifications

	Metric	U.S.
Dimensions		
Height	19.4 cm	7.59 in
Width	34.4 cm	13.54 in
Diagonal	39.6 cm	15.6 in
Surface treatment	Anti-glare	
Contrast ratio	300:1 (typical)	
Refresh rate	60 Hz	
Brightness	200 nits (typical)	
Pixel resolution		
Pitch	0.252 mm	
Format	1366 x 768	
Configuration	RGB stripe	
Backlight	LED	
PPI	100 ppi	
Viewing angle	30/30/20/10 (Left/Right/Down/Up) (minimum) or 45/45/35/25 (Left/Right/Down/Up) (typical)	

39.6-cm (15.6-in) FHD display specifications

	Metric	U.S.
Dimensions		
Height	19.4 cm	7.59 in
Width	34.4 cm	13.54 in
Diagonal	39.6 cm	15.6 in
Surface treatment	Anti-glare	
Contrast ratio	300:1 (typical)	
Refresh rate	60 Hz	
Brightness	220 nits (typical)	
Pixel resolution		
Pitch	0.179 × 0.179 mm	
Format	1920 × 1080	
Configuration	RGB stripe	
Backlight	White LED	
PPI	142 ppi	
Viewing angle	60/60/50/50 (Left/Right/Down/Up) (minimum) or 70/70/60/60 (Left/Right/Down/Up) (typical)	

Hard drive specifications

	750 GB*	500-GB*	320-GB*
Dimensions			
Height	9.5 mm	9.5 mm	9.5 mm
Width	70 mm	70 mm	70 mm
Weight	115 g	115 g	115 g
Interface type	ATA-8, SATA 2.6, 3.0 Gb/s, NCQ	ATA-8, SATA 2.6, 3.0 Gb/s, NCQ	ATA-8, SATA 2.6, 3.0 Gb/s, NCQ
Transfer rate	300 MB/sec	300 MB/sec	300 MB/sec
Security	ATA security	ATA security	ATA security
Seek times (typical read, including setting)			
Single track	1.5 ms	1.5 ms	1.5 ms
Average	11 ms	11 ms	11 ms
Maximum	24 ms	24 ms	24 ms
Logical blocks	1,465,149,168	976,773,168	625,142,448
Disc rotational speed	7200 rpm	7200 rpm	7200 rpm
Operating temperature	32° to 140° F (0° to 60° C)		
*1 GB = 1 billion bytes when referring to hard drive storage capacity. Actual accessible capacity is less. Actual drive specifications may differ slightly.			
NOTE: Certain restrictions and exclusions apply. Contact technical support for details.			

Solid state drive specifications

	256 GB*	128 GB*
Dimensions		
Height	7.0 mm	
Width	70 mm	
Weight	73 g	
Interface type	SATA 3 (6 Gb/s)	
Security	ATA security	
Performance		
Maximum sequential read	Up to 460 MB/s	415 MB/s
Maximum sequential write	Up to 260 MB/s	175 MB/s
Logical blocks	500,118,192	250,069,680
Operating temperature	32° to 158°F (0° to 70°C)	
<p>*1 GB = 1 billion bytes when referring to solid state drive storage capacity. Actual accessible capacity is less. Actual drive specifications may differ slightly.</p>		
<p>NOTE: Certain restrictions and exclusions apply. Contact technical support for details.</p>		

DVD±RW and CD-RW SuperMulti DL Combo Drive specifications

Supported Media	Read: CD-DA, CD-TEXT, CD-ROM, CD-ROM XA, MIXED MODE CD, CD-I, CD-I Bridge (Photo-CD, Video CD), Multisession CD (Photo-CD, CD-EXTRA, Portfolio, CD-R, CD-RW), CD-R, CD-RW, DVD-ROM (DVD-5, DVD-9, DVD-10, DVD-18), DVD-R, DVD-RW, DVD+R, DVD+RW, DVD-RAM	Write: CD-R, CD-RW, DVD+R, DVD+RW, DVD-R, DVD-RW, DVD-RAM, DVD+R DL, DVD-R DL
Access time	CD	DVD
Random	<140ms	< 160 ms
Interface	Gen 1 SATA	
Max data transfer rate	<ul style="list-style-type: none"> • 24X CD-ROM • 8X DVD • 24X CD-R • 24X CD-RW • 8X DVD+R • 8X DVD+RW • 8X DVD-R • 6X DVD-RW • 6X - DVD+R Dual Layer • 6X - DVD-R Dual Layer • 5X DVD-RAM 	
Transfer mode	UDMA Mode 5	
Max Media Capacity (read/write)	8.5 GB	
Transport	Tray Loading	

Blu-ray Disc ROM DVD±RW SuperMulti DL Combo Drive

Supported Media	Read:	Write:		
	CD-DA, , CD-TEXT, CD-ROM, CD-ROM XA, MIXED MODE CD, CD-I, CD-I Bridge (Photo-CD, Video CD), Multisession CD (Photo-CD, CD-EXTRA, Portfolio, CD-R, CD-RW), CD-R, CD-RW, DVD-ROM (DVD-5, DVD-9, DVD-10, DVD-18), DVD-R, DVD-RW, DVD+R, DVD+RW. DVD-RAM, BD-ROM, BD-R, BD-RE	CD-R, CD-RW, DVD+R, DVD+R DL, DVD+RW, DVD-R, DVD-R DL, DVD-RW, DVD-RAM		
Access time	CD-ROM	DVD_ROM	BD-ROM	
Random	<190 ms	< 180ms	<230 ms	
Interface	Gen 1 SATA			
Max data transfer rate	<ul style="list-style-type: none"> • 24X CD-ROM • 8X DVD • 24X CD-R • 24X CD-RW • 8X DVD+R • 8X DVD+RW • 8X DVD-R • 6X DVD-RW • 6X - DVD+R Dual Layer • 6X - DVD-R Dual Layer • 5X DVD-RAM 			
Transfer mode	UDMA Mode 5			
Max Media Capacity (read)	50.0 GB			
Max Media Capacity (/write)	8.5 GB			
Transport	Tray Loading			

DVD-ROM Drive specifications

Supported Media	CD-DA, CD-TEXT, CD-ROM, CD-ROM XA, MIXED MODE CD, CD-I, CD-I Bridge (Photo-CD, Video CD), Multisession CD (Photo-CD, CD-EXTRA, Portfolio, CD-R, CD-RW), CD-R, CD-RW, DVD-ROM (DVD-5, DVD-9, DVD-10, DVD-18), DVD-R, DVD-RW, DVD+R, DVD+RW, DVD-RAM	
Access time	CD	DVD
Random	< 140 ms	< 160 ms
Interface	Gen 1 SATA	
Max data transfer rate	<ul style="list-style-type: none">• 24X CD-ROM• 8X DVD	
Transfer mode	UDMA Mode 5	
Max Media Capacity (read)	8.5 GB	
Transport	Tray Loading	

7 Backup and recovery

Windows 8

To protect your information, use Windows backup and restore utilities to back up individual files and folders, back up your entire hard drive, create system repair media (select models only) by using the installed optical drive (select models only) or an optional external optical drive, or create system restore points. In case of system failure, you can use the backup files to restore the contents of your computer.

From the Start screen, type `restore`, click **Settings**, and then select from the list of displayed options.

 **NOTE:** For detailed instructions on various backup and restore options, perform a search for these topics in Help and Support. From the Start screen, type `h`, and then select **Help and Support**.

In case of system instability, HP recommends that you print the recovery procedures and save them for later use.

 **NOTE:** Windows includes the User Account Control feature to improve the security of your computer. You may be prompted for your permission or password for tasks such as installing software, running utilities, or changing Windows settings. Refer to Help and Support for more information. From the Start screen, type `h`, and then select **Help and Support**.

Backing up your information

Recovery after a system failure is as good as your most recent backup. You should create system repair media and your initial backup immediately after initial system setup. As you add new software and data files, you should continue to back up your system on a regular basis to maintain a reasonably current backup. As you add new software and data files, you should continue to back up your system on a regular basis to maintain a reasonably current backup. The system repair media (select models only) are used to start up (boot) the computer and repair the operating system in case of system instability or failure. Your initial and subsequent backups allow you to restore your data and settings if a failure occurs.

From the Start screen, type `backup`, click **Settings**, and then select **Save backup copies of your files with File History**.

You can back up your information to an optional external hard drive or a network drive.

Note the following when backing up:

- Store personal files in the Documents library, and back it up regularly.
- Back up templates that are stored in their associated programs.
- Save customized settings that appear in a window, toolbar, or menu bar by taking a screen shot of your settings. The screen shot can be a time-saver if you have to reset your preferences.

To create a backup using Backup and Restore:

 **NOTE:** Be sure that the computer is connected to AC power before you start the backup process.

 **NOTE:** The backup process may take over an hour, depending on file size and the speed of the computer.

1. From the Start screen, type `backup`, click **Settings**, and then select from the list of displayed options.
2. Follow the on-screen instructions to set up your backup, create a system image (select models only), or create system repair media (select models only).

Performing a system recovery

In case of system failure or instability, the computer provides the following tools to recover your files:

- Windows recovery tools: You can use Windows Backup and Restore to recover information you have previously backed up. You can also use Windows Startup Repair to fix problems that might prevent Windows from starting correctly.
- **f11** recovery tools: You can use the **f11** recovery tools to recover your original hard drive image. The image includes the Windows operating system and software programs installed at the factory.

 **NOTE:** If you are unable to boot (start up) your computer and you cannot use the system repair media you previously created (select models only), you must purchase Windows 8 operating system media to reboot the computer and repair the operating system. For additional information, see the “Using Windows 8 operating system media (purchased separately)” section.

Using the Windows recovery tools

To recover information you previously backed up:

- ▲ From the Start screen, type `h`, and then select **Help and Support**.

To recover your information using Startup Repair, follow these steps:

 **CAUTION:** Some Startup Repair options will completely erase and reformat the hard drive. All files you have created and any software installed on the computer are permanently removed. When reformatting is complete, the recovery process restores the operating system, as well as the drivers, software, and utilities from the backup used for recovery.

1. If possible, back up all personal files.
2. If possible, check for the presence of the HP Recovery partition and the Windows partition.

From the Start screen, type `e`, and then click **File Explorer**.

– or –

From the Start screen, type `c`, and then select **Computer**.

 **NOTE:** If the Windows partition and the HP Recovery partition are not listed, you must recover your operating system and programs using the Windows 8 operating system DVD and the Driver Recovery media (both purchased separately). For additional information, see the “Using Windows 8 operating system media (purchased separately)” section.

3. If the Windows partition and the HP Recovery partition are listed, restart the computer. After Windows has loaded, press and hold the `shift` key while clicking **Restart**.
4. Select **Startup Repair**.
5. Follow the on-screen instructions.

 **NOTE:** For additional information on recovering information using the Windows tools, perform a search for these topics in Help and Support. From the Start screen, type `h`, and then select **Help and Support**.

Using f11 recovery tools

 **CAUTION:** Using `f11` completely erases hard drive contents and reformats the hard drive. All files that you have created and any software that you have installed on the computer are permanently removed. The `f11` recovery tool reinstalls the operating system and HP programs and drivers that were installed at the factory. Software not installed at the factory must be reinstalled.

To recover the original hard drive image using `f11`:

1. If possible, back up all personal files.
2. If possible, check for the presence of the HP Recovery partition: From the Start screen, type `c`, and then select **Computer**.

 **NOTE:** If the HP Recovery partition is not listed, you must recover your operating system and programs using the Windows 8 operating system media and the Driver Recovery media (both purchased separately). For additional information, see the “Using Windows 8 operating system media (purchased separately)” section.

3. If the HP Recovery partition is listed, restart the computer, and then press `esc` while the “Press the ESC key for Startup Menu” message is displayed at the bottom of the screen.

4. Press **f11** while the “Press <F11> for recovery” message is displayed on the screen.
5. Follow the on-screen instructions.

Using Windows 8 operating system media (purchased separately)

To order a Windows 8 operating system DVD, go to <http://www.hp.com/support>, select your country or region, and follow the on-screen instructions. You can also order the DVD by calling support. For contact information, see the Worldwide Telephone Numbers booklet included with the computer.

 **CAUTION:** Using a Windows 8 operating system media completely erases hard drive contents and reformats the hard drive. All files that you have created and any software that you have installed on the computer are permanently removed. When reformatting is complete, the recovery process helps you restore the operating system, as well as drivers, software, and utilities.

To initiate recovery using a Windows 8 operating system DVD:

 **NOTE:** This process takes several minutes.

1. If possible, back up all personal files.
2. Restart the computer, and then insert the Windows 8 operating system DVD into the optical drive before the Windows operating system loads.
3. When prompted, press any keyboard key.
4. Follow the on-screen instructions.

After the repair is completed:

1. Eject the Windows 8 operating system media and then insert the *Driver Recovery* media.
2. Install the Hardware Enabling Drivers first, and then install Recommended Applications.

Using Windows Refresh for quick and easy recovery

When your computer is not working properly and you need to regain system stability, the Windows Refresh option allows you to start fresh and keep what is important to you.

 **IMPORTANT:** Refresh removes any traditional applications that were not originally installed on the system at the factory.

 **NOTE:** During Refresh, a list of removed traditional applications will be saved so that you have a quick way to see what you might need to reinstall. See Help and Support for instructions on reinstalling traditional applications. From the Start screen, type **h**, and then select **Help and Support**.

 **NOTE:** You may be prompted for your permission or password when using Refresh. See Windows Help and Support for more information. From the Start screen, type **h**, and then select **Help and Support**.

To start Refresh:

1. On the Start screen, point to the far-right upper or lower corner of the screen to display the charms.
2. Click **Settings**.
3. Click **Change PC settings** in the bottom-right corner of the screen, and then select **General** from the PC settings screen.
4. Under **Refresh your PC without affecting your files**, select **Get started**, and follow the on-screen instructions.

Remove everything and reinstall Windows

Sometimes you want to perform detailed reformatting of your computer, or you want to remove personal information before you give away or recycle your computer. The process described in this section provides a speedy, simple way to return the computer to its original state. This option removes all personal data, apps, and settings from your computer, and reinstalls Windows.



IMPORTANT: This option does not provide backups of your information. Before using this option, back up any personal information you wish to retain.

You can initiate this option by using the **f11** key or from the Start screen.

To use the **f11** key:

1. Press **f11** while the computer boots.
– or –
Press and hold **f11** as you press the power button.
2. Select **Troubleshoot** from the boot options menu.
3. Select **Reset your PC**, and follow the on-screen instructions.

To use the Start screen:

1. On the Start screen, point to the far-right upper or lower corner of the screen to display the charms.
2. Click **Settings**.
3. Click **Change PC settings** in the bottom-right corner of the screen, and then select **General** from the PC settings screen.
4. Under **Remove everything and reinstall Windows**, select **Get started**, and follow the on-screen instructions.

Using HP Software Setup

HP Software Setup can be used to reinstall drivers or select software that has been corrupted or deleted from the system.

1. From the Start screen, type `HP Software Setup`, and select **Apps**.
2. Open HP Software Setup.
3. Follow the on-screen directions to reinstall drivers or select software.

Windows 7

To protect your information, use Windows Backup and Restore to back up individual files and folders, back up your entire hard drive (select models only), create system repair discs (select models only) with the installed optical drive (select models only) or an optional external optical drive, or create system restore points. In case of system failure, you can use the backup files to restore the contents of your computer.

Windows Backup and Restore provides the following options:

- Creating a system repair disc (select models only) by using the installed optical drive (select models only) or an optional external optical drive
- Backing up your information
- Creating a system image (select models only)
- Scheduling automatic backups (select models only)
- Creating system restore points
- Recovering individual files
- Restoring the computer to a previous state
- Recovering information using recovery tools



NOTE: For detailed instructions, perform a search for these topics in Help and Support.

In case of system instability, HP recommends that you print the recovery procedures and save them for later use.



NOTE: Windows includes the User Account Control feature to improve the security of your computer. You may be prompted for your permission or password for tasks such as installing software, running utilities, or changing Windows settings. See Help and Support for more information.

Creating recovery media with HP Recovery Disc Creator

HP Recovery Disc Creator is a software program that offers an alternative way to create recovery media. After you successfully set up the computer, you can create recovery media using HP Recovery Disc Creator. This recovery media allows you to reinstall your original operating system as well as select drivers and applications if the hard drive becomes corrupted.

HP Recovery Disc Creator can create two kinds of recovery DVDs as follows:

- Windows DVD—Installs the operating system without additional drivers or applications.
- Driver DVD—Installs specific drivers and applications only, in the same way that the HP Software Setup utility installs drivers and applications.

Creating recovery media



NOTE: The Windows DVD can be created only once. Thereafter, the option to create that media will not be available.

1. Select **Start > All Programs > Productivity and Tools > HP Recovery Disc Creator**.
2. Select **Driver DVD** or **Windows DVD**.
3. From the drop-down menu, select the drive for burning the recovery media.
4. Click the **Burn** button to start the burning process.

Backing up your information

Recovery after a system failure is as good as your most recent backup. Immediately after setting up the computer, you should create system repair discs (select models only) using the installed optical drive (select models only) or an optional external optical drive and back up your system. As you add new software and data files, you should continue to back up your system on a regular basis to maintain a reasonably current backup. The system repair discs (select models only) are used to start up (boot) the computer and repair the operating system in case of system instability or failure. Your initial and subsequent backups allow you to restore your data and settings if a failure occurs.

You can back up your information to an optional external hard drive, a network drive, or discs.

Note the following when backing up:

- Store personal files in the Documents library, and back it up regularly.
- Back up templates that are stored in their associated programs.
- Save customized settings that appear in a window, toolbar, or menu bar by taking a screen shot of your settings. The screen shot can be a time-saver if you have to reset your preferences.
- When backing up to discs, use any of the following types of discs (purchased separately): CD-R, CD-RW, DVD+R, DVD+R DL, DVD-R, DVD-R DL, or DVD±RW. The discs you use will depend on the type of optical drive you are using.

 **NOTE:** DVDs and DVDs with double-layer (DL) support store more information than CDs, so using them for backup reduces the number of recovery discs required.

- When backing up to discs, number each disc before inserting it into the external drive.

To create a backup using Backup and Restore:

 **NOTE:** Be sure that the computer is connected to AC power before you start the backup process.

 **NOTE:** The backup process may take over an hour, depending on file size and the speed of the computer.

1. Select **Start > All Programs > Maintenance > Backup and Restore**.
2. Follow the on-screen instructions to set up your backup, create a system image (select models only), or create a system repair disc (select models only).

Performing a system recovery

In case of system failure or instability, the computer provides the following tools to recover your files:

- Windows recovery tools: You can use Windows Backup and Restore to recover information you have previously backed up. You can also use Windows Startup Repair to fix problems that might prevent Windows from starting correctly.
- **f11** recovery tools: You can use the **f11** recovery tools to recover your original hard drive image. The image includes the Windows operating system and software programs installed at the factory.

 **NOTE:** If you are unable to boot (start up) your computer and you cannot use the system repair discs you previously created (select models only), you must purchase a Windows 7 operating system DVD to reboot the computer and repair the operating system. For additional information, see the Using a Windows 7 operating system DVD (purchased separately) section.

Using the Windows recovery tools

To recover information you previously backed up:

1. Select **Start > All Programs > Maintenance > Backup and Restore**.
2. Follow the on-screen instructions to recover your system settings, your computer (select models only), or your files.

To recover your information using Startup Repair, follow these steps:

 **CAUTION:** Some Startup Repair options completely erase hard drive contents and reformat the hard drive. All files you have created and any software installed on the computer are permanently removed. When reformatting is complete, the recovery process restores the operating system, as well as the drivers, software, and utilities from the backup used for recovery.

1. If possible, back up all personal files.
2. If possible, check for the presence of the Windows partition.

To check for the Windows partition, select **Start > Computer**.

3. If the Windows partition is listed, restart the computer, and then press **f8** before the Windows operating system loads.
4. Select **Startup Repair**.
5. Follow the on-screen instructions.

 **NOTE:** For additional information on recovering information using the Windows tools, perform a search for these topics in Help and Support.

Using f11 recovery tools

 **CAUTION:** Using **f11** recovery tools completely erases hard drive contents and reformats the hard drive. All files you have created and any software installed on the computer are permanently removed. The **f11** recovery tool reinstalls the operating system and HP programs and drivers that were installed at the factory. Software not installed at the factory must be reinstalled.

To recover the original hard drive image using **f11**:

1. If possible, back up all personal files.
2. If possible, check for the presence of the HP Recovery partition: click **Start**, right-click **Computer**, click **Manage**, and then click **Disk Management**.

 **NOTE:** If the HP Recovery partition has been deleted, the **f11** restore option will not function. You must recover your operating system and programs using the Windows 7 operating system DVD and the Driver Recovery disc (both purchased separately) if the Windows partition and the HP Recovery partition are not listed. For additional information, see the Using a Windows 7 operating system DVD (purchased separately) section.

3. If the HP Recovery partition is listed, restart the computer, and then press **esc** while the “Press the ESC key for Startup Menu” message is displayed at the bottom of the screen.
4. Press **f11** while the “Press <F11>” for recovery” message is displayed on the screen.
5. Follow the on-screen instructions.

Using a Windows 7 operating system DVD (purchased separately)

To order a Windows 7 operating system DVD, go to the HP website. For U.S. support, go to <http://www.hp.com/go/contactHP>. For worldwide support, go to http://welcome.hp.com/country/us/en/wwcontact_us.html. You can also order the DVD by calling support. For contact information, see the *Worldwide Telephone Numbers* booklet included with the computer.

 **CAUTION:** Using a Windows 7 operating system DVD completely erases hard drive contents and reformats the hard drive. All files you have created and any software installed on the computer are permanently removed. When reformatting is complete, the recovery process helps you restore the operating system, as well as drivers, software, and utilities.

To initiate recovery using a Windows 7 operating system DVD:

 **NOTE:** This process takes several minutes.

1. If possible, back up all personal files.
2. Restart the computer, and then insert the Windows 7 operating system DVD into the optical drive before the Windows operating system loads.
3. When prompted, press any keyboard key.
4. Follow the on-screen instructions.
5. Click **Next**.
6. Select **Repair your computer**.
7. Follow the on-screen instructions.

After the repair is completed:

1. Eject the Windows 7 operating system DVD, and then insert the Driver Recovery disc.
2. Install the Hardware Enabling Drivers first, and then install Recommended Applications.

8 Power cord set requirements

The wide range input feature of the computer permits it to operate from any line voltage from 100 to 120 volts AC, or from 220 to 240 volts AC.

The 3-conductor power cord set included with the computer meets the requirements for use in the country or region where the equipment is purchased.

Power cord sets for use in other countries and regions must meet the requirements of the country or region where the computer is used.

Requirements for all countries and regions

The requirements listed below are applicable to all countries and regions:

- The length of the power cord set must be at least **1.0 m** (3.3 ft) and no more than **2.0 m** (6.5 ft).
- All power cord sets must be approved by an acceptable accredited agency responsible for evaluation in the country or region where the power cord set will be used.
- The power cord sets must have a minimum current capacity of 10 amps and a nominal voltage rating of 125 or 250 V AC, as required by the power system of each country or region.
- The appliance coupler must meet the mechanical configuration of an EN 60 320/IEC 320 Standard Sheet C13 connector for mating with the appliance inlet on the back of the computer.

Requirements for specific countries and regions

Country/region	Accredited agency	Applicable note number
Australia	EANSW	1
Austria	OVE	1
Belgium	CEBC	1
Canada	CSA	2
Denmark	DEMKO	1
Finland	FIMKO	1
France	UTE	1
Germany	VDE	1
Italy	IMQ	1
Japan	METI	3
The Netherlands	KEMA	1
Norway	NEMKO	1
The People's Republic of China	CCC	5
South Korea	EK	4
Sweden	SEMKO	1
Switzerland	SEV	1
Taiwan	BSMI	4
The United Kingdom	BSI	1
The United States	UL	2

1. The flexible cord must be Type HO5VV-F, 3-conductor, 1.0-mm² conductor size. Power cord set fittings (appliance coupler and wall plug) must bear the certification mark of the agency responsible for evaluation in the country or region where it will be used.
2. The flexible cord must be Type SPT-3 or equivalent, No. 18 AWG, 3-conductor. The wall plug must be a two-pole grounding type with a NEMA 5-15P (15 A, 125 V) or NEMA 6-15P (15 A, 250 V) configuration.
3. The appliance coupler, flexible cord, and wall plug must bear a "T" mark and registration number in accordance with the Japanese Dentori Law. The flexible cord must be Type VCT or VCTF, 3-conductor, 1.00-mm² conductor size. The wall plug must be a two-pole grounding type with a Japanese Industrial Standard C8303 (7 A, 125 V) configuration.
4. The flexible cord must be Type RVV, 3-conductor, 0.75-mm² conductor size. Power cord set fittings (appliance coupler and wall plug) must bear the certification mark of the agency responsible for evaluation in the country or region where it will be used.
5. The flexible cord must be Type VCTF, 3-conductor, 0.75-mm² conductor size. Power cord set fittings (appliance coupler and wall plug) must bear the certification mark of the agency responsible for evaluation in the country or region where it will be used.

9 Recycling

When a non-rechargeable or rechargeable battery has reached the end of its useful life, do not dispose of the battery in general household waste. Follow the local laws and regulations in your area for battery disposal.

HP encourages customers to recycle used electronic hardware, HP original print cartridges, and rechargeable batteries. For more information about recycling programs, see the HP Web site at <http://www.hp.com/recycle>.

Index

Symbols/Numerics

1394 port, identifying 17

A

AC adapter, spare part number 35

accessory battery connector, identifying 20

antennas, disconnecting 68

audio, product description 3

audio-in (microphone) jack, identifying 16

audio-out (headphone) jack, identifying 16

Audio/USB 3.0 board
spare part number 27

audio/USB 3.0 board
removal 106
spare part number 106

B

base enclosure, spare part number 29

battery
removal 54
spare part number 29, 38, 54

battery bay, identifying 20

battery cover, illustrated 32

battery latch removal 128

battery light 14

battery release latch 20

Blu-ray Disc R/RE DVD±RW
SuperMulti DL Drive
removal 77
spare part number 30, 34, 77

Blu-ray Disc ROM DVD±RW
SuperMulti DL Combo Drive
removal 77

spare part
694689-001 number 30
spare part number 34, 77
specifications 154

Bluetooth cable, illustrated 33

Bluetooth compartment,
identifying 21

Bluetooth module
removal 70
spare part number 29, 70

buttons
calculator 12
center pointing stick 8
center TouchPad 8
left pointing stick 8
left TouchPad 8
optical drive eject 16
power 11
right pointing stick 8
right TouchPad 8

C

Cable Kit
contents 33
spare part number 33

cable kit
spare part number 30

cables, service considerations 49

calculator button, identifying 12

calculator light 10

caps lock light, identifying 10

chipset, product description 1

components
bottom 20
display 19
front 14
left side 17
rear 18

right side 16
top 8

computer specifications 148

connector, power 18

connectors, service
considerations 49

D

diskette drive, precautions 49

display assembly
removal 130
spare part number 24, 130

display bezel
removal 55
spare part number 31

display components, spare part
number 31

display hinges, spare part
number 31, 38

display latch button, illustrated 32

display latch kit, spare part
number 38

display panel
product description 2
removal 55

spare part number 31, 55

display release latch 14

display specifications 149, 150

DisplayPort, identifying 17

docking connector, identifying 20

docking support, product
description 5

drives
preventing damage 49

DVD-ROM Drive
precautions 49
removal 77
spare part number 30, 34, 77
specifications 155

DVD±RW and CD-RW SuperMulti
DL Combo Drive
precautions 49
removal 77
spare part number 30, 34, 77

E

electrostatic discharge 50
eSATA port 17
esc key, identifying 13
Ethernet, product description 3
ExpressCard blank, illustrated 32
ExpressCard/USB 2.0 assembly
removal 113
spare part number 113
external media cards, product
description 4
external monitor port 16

F

fingerprint reader board
removal 94
spare part number 94
fingerprint reader, identifying 12
fn key, identifying 13
function button board
removal 92
spare part number 92
function keys, identifying 13

G

graphics card
removal 102
spare part number 28, 102
graphics, product description 1
grounding equipment and
methods 52

H

hard drive
precautions 49
product description 3
removal 72
spare part number 34, 38, 72
spare part numbers 30
specifications 151, 152
hard drive bracket, removal 74
hard drive hardware kit, spare part
number 38
hard drive light 14
hard drive, identifying 21

headphone (audio-out) jack 16
hinge cover
removal 130
spare part number 29, 131
hinge cover, spare part number
38
hinges, spare part number 31, 38
HP Logo Kit
spare part number 38
HP Logo Kit, spare part number
31

I

integrated numeric keypad,
identifying 13
integrated webcam light,
identifying 19
internal display switch 19
internal microphones, identifying
19
inverter cover, illustrated 32

J

jacks
audio-in (microphone) 16
audio-out (headphone) 16
network 17
RJ-11 (modem) 18
RJ-45 (network) 17

K

keyboard
product description 5
removal 81
spare part number 81
spare part numbers 24, 44,
45, 46, 47
keypad
integrated numeric 13
keys
esc 13
fn 13
function 13
Windows applications 13
Windows logo 13

L

latches, battery release 20
lights
battery 14
calculator 10

caps lock 10
hard drive 14
num lk 10
power 10, 14
TouchPad 10
webcam 19
wireless 10

M

mass storage devices, spare part
number 34
Media Card Reader, identifying
15
memory module
identifying 21
product description 2
spare part number 62, 85
under keyboard
;identifying 62, 85
;removal 62, 85
microphone (audio-in) jack
product description 3
microphone (audio-in) jack,
identifying 16
model name 1
modem module
product description 3
removal 108
spare part number 38, 108

N

network jack, identifying 17
Northbridge chip heat sink
removal 115
num lk light 10

O

operating system, product
description 6
optical drive
precautions 49
product description 3
removal 77
spare part number 30, 34, 77
specifications 153, 154, 155
optical drive eject button,
identifying 16
optical drive weight saver
illustrated 32

P

- packing guidelines 51
- PCH thermal material
 - spare part number 39
- plastic parts 48
- Plastics Kit
 - contents 32
 - spare part number 32
- pointing device, product description 5
- pointing stick 8
- pointing stick cover
 - spare part number 39
- ports
 - 1394 17
 - DisplayPort 17
 - external monitor 16
 - product description 4
 - USB 17
 - USB charging 17
- power button board
 - removal 90
 - spare part number 90
- power button, identifying 11
- power connector cable
 - illustrated 33
 - removal 122
 - spare part number 122
- power connector, identifying 18
- power cord
 - set requirements 166
 - spare part number 37
 - spare part numbers 35
- power lights 10, 14
- power requirements, product description 5
- processor
 - product description 1
 - removal 104
 - spare part number 27, 104
 - spare part numbers 44
- product description
 - audio 3
 - chipset 1
 - display panel 2
 - docking support 5
 - Ethernet 3
 - external media cards 4
 - graphics 1
 - hard drives 3

- keyboard 5
- memory module 2
- microphone 3
- modem module 3
- operating system 6
- optical drives 3
- pointing devices 5
- ports 4
- power requirements 5
- processors 1
- product name 1
- security 5
- serviceability 7
- webcam 3
- wireless 4

product name 1

R

- removal/replacement
 - preliminaries 48
 - procedures 53
- RJ-11 (modem) jack
 - spare part number 27
- RJ-11 (modem) jack, identifying 18
- RJ-11 connector cable
 - removal 124
- RJ-11 jack cover
 - illustrated 32
- RJ-45 (network) jack, identifying 17
- RJ-45 connector cable
 - removal 120
- RTC battery
 - removal 64
 - spare part number 38, 64
- Rubber Kit, spare part number 38

S

- Screw Kit, spare part number 36, 38
- SD Card blank, illustrated 32
- security cable slot, identifying 17
- security, product description 5
- service considerations 48
- service door 21
 - removal 60
 - spare part number 38, 60
- service door latch
 - removal 126

- service tag 22, 53
- serviceability, product description 7
- SIM slot, identifying 20
- SIM, removal 59
- slots
 - security cable 17
 - SIM 20
- smart card bracket, spare part number 39
- smart card reader
 - removal 75
 - spare part number 39, 75
- smart card reader, identifying 16
- solid-state drive
 - spare part numbers 47
- solid-state drive, spare part number 34, 72
- solid-state drive, spare part numbers 30
- speakers
 - removal 110
 - spare part number 29, 39, 110
- specifications
 - Blu-ray Disc ROM DVD±RW SuperMulti DL Combo Drive 154
 - computer 148
 - display 149, 150
 - DVD-ROM Drive 155
 - DVD±RW and CD-RW SuperMulti DL Combo Drive 153
 - hard drive 151, 152
 - optical drive 153, 154, 155
- static-shielding materials 52
- system board
 - removal 117
 - spare part number 28, 117
 - spare part numbers 40, 47

T

- tools required 48
- top cover
 - removal 87
 - spare part number 27, 87
- TouchPad
 - buttons 8
 - on/off button 12

- TouchPad button board
 - removal 96
 - spare part number 96
- TouchPad light, identifying 10
- TouchPad zone
 - identifying 9
- transporting guidelines 51

U

- upgrade bay 16
- upgrade bay bezel, spare part number 78
- upgrade bay hard drive, removal 78
- USB 3.0 port 16
- USB charging port 17
- USB ports, identifying 16, 17

V

- vents, identifying 17, 20
- VGA port board
 - removal 98
 - spare part number 98

W

- webcam 19
 - product description 3
- webcam light, identifying 19
- webcam module, spare part number 31
- webcam, identifying 19
- Windows applications key, identifying 13
- Windows logo key, identifying 13
- wireless antennas
 - disconnecting 66, 68
- wireless antennas, identifying 19
- wireless light 10
- wireless, product description 4
- WLAN antennas, identifying 19
- WLAN module
 - removal 65
 - spare part number 29, 38, 65
 - spare part numbers 43
- workstation guidelines 51
- WWAN antennas, identifying 19
- WWAN module
 - removal 68
 - spare part number 29, 38, 68
 - spare part numbers 44, 47

