



## HP ENVY x360 Convertible PC

Maintenance and Service Guide

**IMPORTANT!** This document is intended for HP authorized service providers only.

© Copyright 2014 Hewlett-Packard Development Company, L.P.

Intel and Pentium are trademarks of Intel Corporation in the U.S. and other countries. Bluetooth is a trademark owned by its proprietor and used by Hewlett-Packard Company under license. Microsoft, Windows, Windows 7, and Windows 8 are U.S. registered trademarks of the Microsoft group of companies. SD Logo is a trademark of its proprietor.

The information contained herein is subject to change without notice. The only warranties for HP products and services are set forth in the express warranty statements accompanying such products and services. Nothing herein should be construed as constituting an additional warranty. HP shall not be liable for technical or editorial errors or omissions contained herein.

Second Edition: November 2014

First Edition: June 2014

Document Part Number: 767037-002

## **Product notice**

This guide describes features that are common to most models. Some features may not be available on your computer.

Not all features are available on all editions of Windows 8. This computer may require upgraded and/or separately purchased hardware, drivers, and/or software to take full advantage of Windows 8 functionality. See <http://www.microsoft.com> for details.

This computer may require upgraded and/or separately purchased hardware and/or a DVD drive to install the Windows 7 software and take full advantage of Windows 7 functionality. See <http://windows.microsoft.com/en-us/windows7/get-know-windows-7> for details.

## Safety warning notice

---

 **WARNING!** To reduce the possibility of heat-related injuries or of overheating the device, do not place the device directly on your lap or obstruct the device air vents. Use the device only on a hard, flat surface. Do not allow another hard surface, such as an adjoining optional printer, or a soft surface, such as pillows or rugs or clothing, to block airflow. Also, do not allow the AC adapter to contact the skin or a soft surface, such as pillows or rugs or clothing, during operation. The device and the AC adapter comply with the user-accessible surface temperature limits defined by the International Standard for Safety of Information Technology Equipment (IEC 60950).

---



---

# Table of contents

<b>1 Product description .....</b>	<b>1</b>
<b>2 External component identification .....</b>	<b>4</b>
Right side .....	4
Left side .....	5
Display .....	6
Display modes .....	7
Top .....	8
TouchPad .....	8
Lights .....	9
Buttons and speakers .....	10
Keys .....	11
Bottom .....	12
Service tag and PCID label .....	13
Service tag .....	13
PCID label .....	14
<b>3 Illustrated parts catalog .....</b>	<b>15</b>
Computer major components .....	15
Display assembly subcomponents .....	19
Mass storage devices .....	20
Miscellaneous parts .....	21
Sequential part number listing .....	21
<b>4 Removal and replacement procedures preliminary requirements .....</b>	<b>25</b>
Tools required .....	25
Service considerations .....	25
Plastic parts .....	25
Cables and connectors .....	25
Drive handling .....	26
Grounding guidelines .....	26
Electrostatic discharge damage .....	26
Packaging and transporting guidelines .....	27
Workstation guidelines .....	27

<b>5 Removal and replacement procedures for Authorized Service Provider parts .....</b>	<b>29</b>
Component replacement procedures .....	29
Top cover .....	30
Battery .....	33
TouchPad board .....	35
Hard drive .....	36
Solid-state drive (SSD) .....	38
WLAN module .....	40
Speakers .....	42
USB/audio board .....	44
Fan .....	45
Power button board .....	47
System board .....	49
Memory module .....	52
Heat sink .....	54
Display assembly .....	56
Power connector cable .....	62
<b>6 Using Setup Utility (BIOS) and HP PC Hardware Diagnostics (UEFI) .....</b>	<b>64</b>
Starting Setup Utility (BIOS) .....	64
Updating the BIOS .....	64
Determining the BIOS version .....	64
Downloading a BIOS update .....	65
Using HP PC Hardware Diagnostics (UEFI) .....	65
Downloading HP PC Hardware Diagnostics (UEFI) to a USB device .....	66
<b>7 Specifications .....</b>	<b>67</b>
Computer specifications .....	67
Hard drive specifications .....	68
Solid-state drive specifications .....	68
<b>8 Backing up, restoring, and recovering .....</b>	<b>69</b>
Creating recovery media and backups .....	69
Creating HP Recovery media .....	69
Restore and recovery .....	70
Recovering using HP Recovery Manager .....	71
What you need to know .....	71
Using the HP Recovery partition (select models only) .....	71
Using HP Recovery media to recover .....	72
Changing the computer boot order .....	72

Removing the HP Recovery partition (select models only) .....	72
<b>9 Power cord set requirements .....</b>	<b>73</b>
Requirements for all countries .....	73
Requirements for specific countries and regions .....	73
<b>10 Recycling .....</b>	<b>75</b>
<b>Index .....</b>	<b>76</b>





# 1 Product description

Category	Description
<b>Product Name</b>	HP ENVY x360 Convertible PC
<b>Processor</b>	<b>5th Generation Intel processors</b>  Intel® Core i7-5500U processor (2.4 GHz, SC turbo up to 3.0 GHz, 1600 MHz, 3 MB L3 cache)  Intel Core i5-5200U processor (2.2 GHz, SC turbo up to 2.7 GHz, 1600 MHz, 3 MB L3 cache)  Intel Core i3-5010U processor (2.1 GHz, 1600 MHz, 3 MB L3 cache)  Intel Core i3-5005U processor (2.0 GHz, 1600 MHz, 3 MB L3 cache)  <b>4th Generation Intel processors</b>  Intel Core i7-4510U processor (2.0 GHz, SC turbo up to 3.1 GHz, 1600 MHz, 4 MB L3 cache)  Intel Core i5-4210U processor (1.7 GHz, SC turbo up to 2.7 GHz, 1600 MHz, 3 MB L3 cache)  Intel Core i5-4200U processor (1.6 GHz, SC turbo up to 2.66 GHz, 1600 MHz, 3 MB L3 cache)  Intel Core i3-4030U processor (1.9 GHz, 1600 MHz, 3 MB L3 cache)
<b>Chipset</b>	Integrated SoC FCH (4th generation processors)  Intel BDW U processor BGA (5th generation processors)
<b>Graphics</b>	<b>Internal graphics:</b>  Intel HD Graphics 5500 (5th generation processors)  Intel HD Graphics 4400 (4th generation processors)  Support for DX11, HD Decode, and HDMI
<b>Panel</b>	15.6-in [39.6-cm] (1920×1080), high-definition (FHD), light emitting diode (LED), AntiGlare, 16:9 ultra-wide aspect ratio; typical brightness: 300 nits; slim (3.2-mm), stand viewing angle  15.6-in [39.6-cm] (1366×768), high-definition (HD), white light emitting diode (WLED), AntiGlare; 16:9 ultra-wide aspect ratio; typical brightness: 200 nits; flat (3.8-mm), stand viewing angle  Touch solution with flush glass, multitouch enabled, touch panel supports Home Key with LED  Supports low-voltage differential signaling (LVDS) (co-layout with eDP1.2)
<b>Memory</b>	Support for 8192-MB of DDR3L-1600-MHz system ram in the following configurations: <ul style="list-style-type: none"><li>• 12288 GB (8192 MB + 4096 MB)(5th generation processors only)</li><li>• 8192 GB (8192 MB × 1 or 4096 MB × 2)</li><li>• 6144 GB (4096 MB × 1 + 2048 MB × 1)</li><li>• 4096 GB (4096 MB × 1 or 2048 MB × 2)</li></ul>
<b>Hard drive</b>	Support for 1P 7mm/2P 7.2mm SATA 2.5-inch hard drive  Support for Accelerometer hard drive protection  Support for the following single hard drive configurations: <ul style="list-style-type: none"><li>• 1-TB, 5400-rpm, 7.2-mm</li><li>• 750-GB, 5400-rpm, 7.2-mm</li></ul>





Category	Description
	<ul style="list-style-type: none"> <li>500-GB, 5400-rpm, 7.0-mm</li> </ul> Support for M2 SATA-3 (NGFF), TLC and MLC: <ul style="list-style-type: none"> <li>256 GB Solid-state drive (SSD)</li> </ul> Support for hybrid hard drive configurations: <ul style="list-style-type: none"> <li>500 GB, 5400-rpm + 8 GB NAND Hybrid hard drive, 7.0 mm</li> </ul>
<b>Optical drive</b>	Support for external 9.5 mm tray load, SATA, DVD+/-RW DL SuperMulti drive
<b>Audio and video</b>	Integrated HP TrueVision camera: HD (1280×720 by 30 frames/sec), fixed (no tilt), with activity light Dual digital microphones with appropriate software - echo cancellation, noise suppression Dual speakers Beats Audio
<b>Ethernet</b>	Gigabit LAN
<b>Sensor</b>	Sensor Hub (Accelerometer + Gyroscope + e-Compass)
<b>Wireless</b>	Integrated wireless options with dual antenna (Half Mini Card): Compatible with Miracast-certified devices Intel WiDi 5.0 support <ul style="list-style-type: none"> <li>Qualcomm QCA9565 802.11bgn 1x1 Wi-Fi + BT4.0 Combo Adapter</li> <li>Intel Dual Band Wireless-AC 7260 802.11 ac 2×2 WiFi + BT 4.0 Combo Adapter</li> <li>Intel Dual Band Wireless-AC 3160 802.11ac 1×1 WiFi + BT 4.0 Combo Adapter</li> <li>Broadcom BCM43142 802.11 bgn 1x1 Wi-Fi + BT4.0 Combo Adapter</li> </ul>
<b>Internal expansion</b>	One half-size mini card slot - support for WLAN One 2280 M.2 daughter board - optional support for SSD
<b>External media cards</b>	HP Multi-Format Digital Media Card Reader with push-push technology. Supports SD/SDHC/SDXC.
<b>Ports</b>	AC adapter: HP Smart pin plug (4.5-mm barrel) Audio: one combo audio-out (headphone)/audio-in (microphone) jack HDMI: v. 1.4, supporting up to 1080p, 1920×1080 at 60 Hz RJ-45/Ethernet (2) USB 3.0 (right side) (1) USB 2.0 (left side)
<b>Keyboard/pointing devices</b>	Full size dura coat backlit keyboard with numeric keypad <b>Touchpad requirements:</b> HP Control Zone Trackpad Taps enabled as default Multitouch gestures enabled – ability to turn on and off Support for PS/2 and SMBus Support for Windows 8.1 Modern TouchPad Gestures
<b>Power requirements</b>	Support for 45-W Smart AC adapter (using 4.5 mm plug) with localized cable plug support

<b>Category</b>	<b>Description</b>
	1 meter power cord Prismatic 3-cell, 43.5-Wh, Li-ion battery
<b>Security</b>	Kensington Lock slot TPM 2.0 support (5th generation processors)
<b>Operating system</b>	<b>Preinstalled:</b> Windows 8.1 Update
<b>Serviceability</b>	<b>End user replaceable parts:</b> <ul style="list-style-type: none"><li>• AC adapter</li></ul>

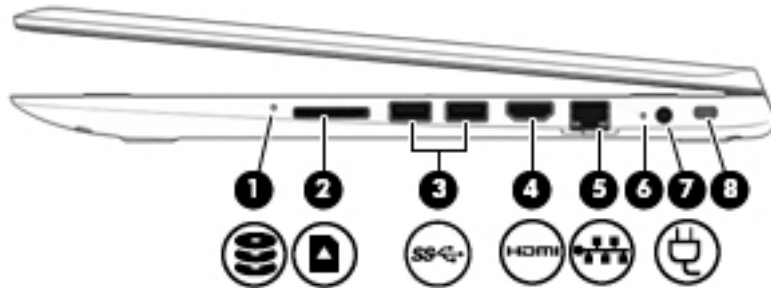
## 2 External component identification



### Right side

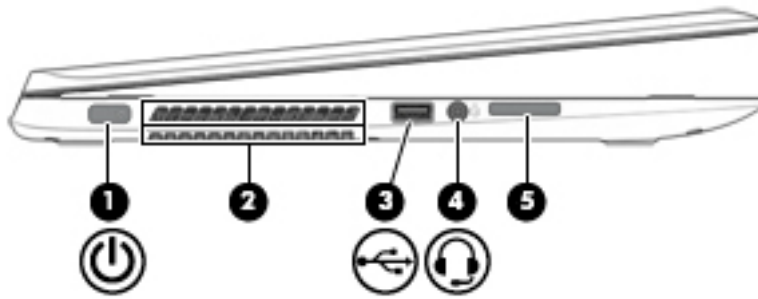

Component	Description
(1) 	<p>Hard drive light</p> <ul style="list-style-type: none"><li>Blinking white: The hard drive is being accessed.</li><li>Amber: HP 3D DriveGuard has temporarily parked the hard drive.</li></ul>
(2) 	<p>Memory card reader</p> <p>Reads optional memory cards that store, manage, share, or access information.</p> <p>To insert a card:</p> <p>Hold the card label-side up, with connectors facing the slot, insert the card into the slot, and then push in on the card until it is firmly seated.</p> <p>To remove a card:</p> <p>Press in on the card it until it pops out.</p>
(3) 	<p>USB 3.0 ports (2)</p> <p>Each USB 3.0 port connects an optional USB device, such as a keyboard, mouse, external drive, printer, scanner or USB hub.</p>
(4) 	<p>HDMI port</p> <p>Connects an optional video or audio device, such as a high-definition television, any compatible digital or audio component, or a high-speed HDMI device.</p>
(5) 	<p>RJ-45 (network) jack/status lights</p> <p>Connects a network cable.</p> <ul style="list-style-type: none"><li>White: The network is connected.</li><li>Amber: Activity is occurring on the network.</li></ul>
(6)	<p>AC adapter light</p> <ul style="list-style-type: none"><li>On: The AC adapter is connected and the battery is charged.</li><li>Off: The computer is using battery power.</li></ul>
(7)	<p>Power connector</p> <p>Connects an AC adapter.</p>
(8)	<p>Security cable slot</p> <p>Attaches an optional security cable to the computer.</p> <p><b>NOTE:</b> The security cable is designed to act as a deterrent, but it may not prevent the computer from being mishandled or stolen.</p>

## Left side



Component	Description
<b>(1)</b>  Power button	<ul style="list-style-type: none"> <li>When the computer is off, press the button to turn on the computer.</li> <li>When the computer is on, press the button briefly to initiate Sleep.</li> <li>When the computer is in the Sleep state, press the button briefly to exit Sleep.</li> <li>When the computer is in Hibernation, press the button briefly to exit Hibernation.</li> </ul> <p><b>CAUTION:</b> Pressing and holding down the power button will result in the loss of unsaved information.</p> <p>If the computer has stopped responding and Windows shutdown procedures are ineffective, press and hold the power button down for at least 5 seconds to turn off the computer.</p> <p>To learn more about your power settings, see your power options. From the Start screen, type <code>power</code>, select <b>Power and sleep settings</b>, and then select <b>Power and sleep</b> from the list of applications.</p>
<b>(2)</b> Vent	<p>Enables airflow to cool internal components.</p> <p><b>NOTE:</b> The computer fan starts up automatically to cool internal components and prevent overheating. It is normal for the internal fan to cycle on and off during routine operation.</p>
<b>(3)</b>  USB 2.0 port	<p>Connects an optional USB device, such as a keyboard, mouse, external drive, printer, scanner or USB hub.</p>
<b>(4)</b>  Audio-out (headphone)/Audio-in (microphone) jack	<p>Connects optional powered stereo speakers, headphones, earbuds, a headset, or a television audio cable. Also connects an optional headset microphone. This jack does not support optional microphone-only devices.</p> <p><b>WARNING!</b> To reduce the risk of personal injury, adjust the volume before putting on headphones, earbuds, or a headset. For additional safety information, refer to the <i>Regulatory, Safety, and Environmental Notices</i>. To access this guide, from the Start screen, type <code>support</code>, and then select the <b>HP Support Assistant</b> app.</p> <p><b>NOTE:</b> When a device is connected to the jack, the computer speakers are disabled.</p> <p><b>NOTE:</b> Be sure that the device cable has a 4-conductor connector that supports both audio-out (headphone) and audio-in (microphone).</p>
<b>(5)</b> Volume button	<p>Controls speaker volume on the tablet.</p> <ul style="list-style-type: none"> <li>To increase speaker volume, press the <b>+</b> edge of the button.</li> </ul>

Component	Description
	<ul style="list-style-type: none"> <li>To decrease speaker volume, press the – edge of the button.</li> </ul>

## Display







Component	Description
(1) WLAN antennas (2)*	Send and receive wireless signals to communicate with wireless local area networks (WLANs).
(2) Internal microphones (2)	Record sound.
(3) Webcam light	On: The webcam is in use.
(4) Webcam	Records video and captures photographs. Some models allow you to video conference and chat online using streaming video.  To use the webcam, from the Start screen, type <code>camera</code> , and then select <b>Camera</b> from the list of applications.

\*The antennas are not visible from the outside of the computer. For optimal transmission, keep the areas immediately around the antennas free from obstructions. For wireless regulatory notices, see the section of the *Regulatory, Safety, and Environmental Notices* that applies to your country or region. To access this guide, from the Start screen, type `support`, and then select the **HP Support Assistant** app.

# Display modes

Your computer has a hinge that allows you to rotate the display 360 degrees. This allows you to use your computer in three modes: productivity mode, entertainment mode, or tablet mode.

Mode		Description
<b>Productivity mode</b>		To use the notebook in productivity mode, raise the display until you can view the display (about 90 to 100 degrees).
<b>Entertainment mode</b>	 	To use your notebook in entertainment mode, raise the display, and then rotate it backward to a stand position (about 315 degrees). You can rest the notebook on the computer bottom or stand it on the front edges. <b>NOTE:</b> The Touchpad and keyboard functions are locked during this mode.
<b>Tablet mode</b>		To use your notebook as a tablet, raise the display, and then rotate it backward until it is flush with the computer bottom (360 degrees). <b>NOTE:</b> The Touchpad and keyboard functions are locked during this mode.

# Top

## TouchPad

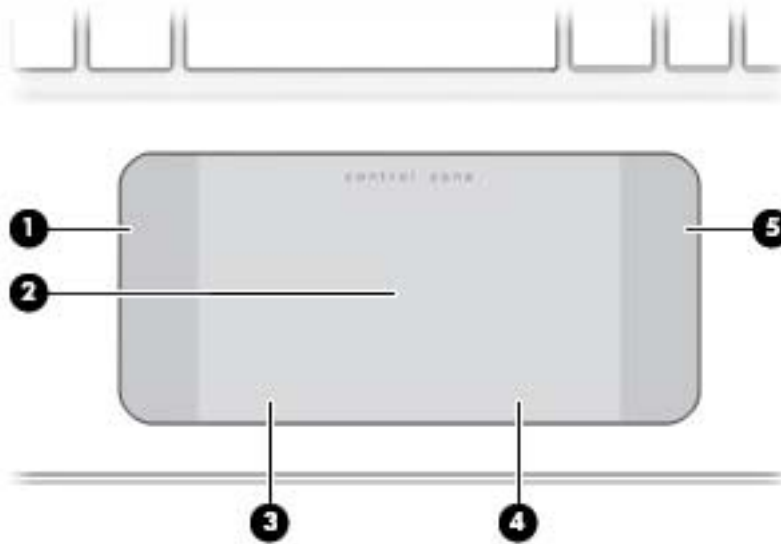



Component		Description
(1)	Left control zone	Textured area that allows you to perform additional gestures.
(2)	TouchPad zone	Reads your finger gestures to move the pointer or activate items on the screen. <b>NOTE:</b> The TouchPad also supports edge-swipe gestures.
(3)	Left TouchPad button	Functions like the left button on an external mouse.
(4)	Right TouchPad button	Functions like the right button on an external mouse.
(5)	Right control zone	Textured area that allows you to perform additional gestures.



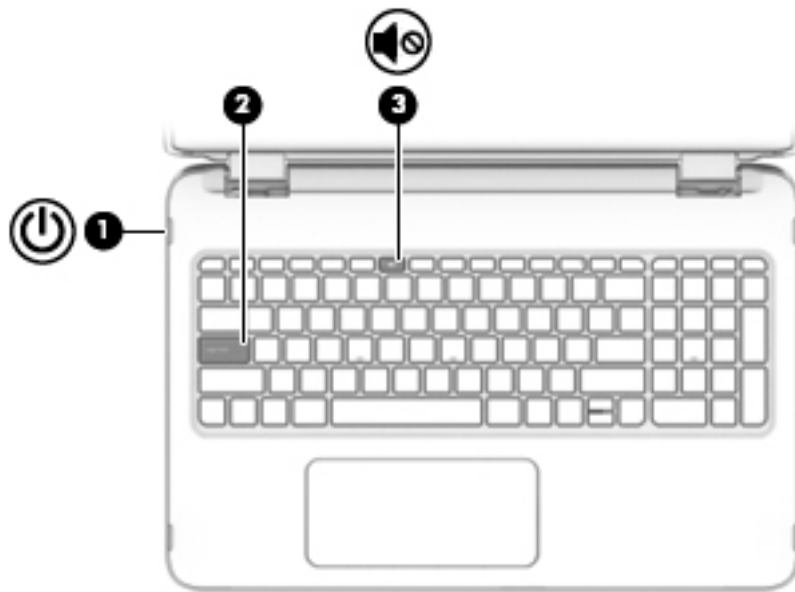

## Lights

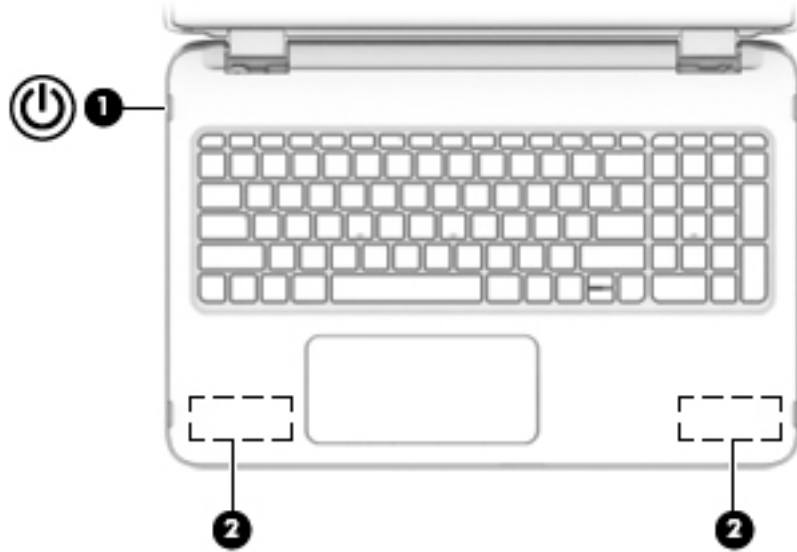

Component	Description
(1)  Power light	<ul style="list-style-type: none"><li>• On: The computer is on.</li><li>• Blinking: The computer is in the Sleep state, a power-saving state. The computer shuts off power to the display and other unneeded components.</li><li>• Off: The computer is off or in Hibernation. Hibernation is a power-saving state that uses the least amount of power.</li></ul>
(2) Caps lock light	On: Caps lock is on, which switches the keys to all capital letters.
(3)  Mute light	<ul style="list-style-type: none"><li>• Amber: Computer sound is off.</li><li>• Off: Computer sound is on.</li></ul>

## Buttons and speakers



Component	Description
(1)  Power button	<ul style="list-style-type: none"><li>• When the computer is off, press the button to turn on the computer.</li><li>• When the computer is on, press the button briefly to initiate Sleep.</li><li>• When the computer is in the Sleep state, press the button briefly to exit Sleep.</li><li>• When the computer is in Hibernation, press the button briefly to exit Hibernation.</li></ul> <p><b>CAUTION:</b> Pressing and holding down the power button will result in the loss of unsaved information.</p> <p>If the computer has stopped responding and Windows shutdown procedures are ineffective, press and hold the power button down for at least 5 seconds to turn off the computer.</p> <p>To learn more about your power settings, see your power options. From the Start screen, type <code>power</code>, select <b>Power and sleep settings</b>, and then select <b>Power and sleep</b> from the list of applications.</p>
(2) Speakers (2)	Produce sound.

## Keys

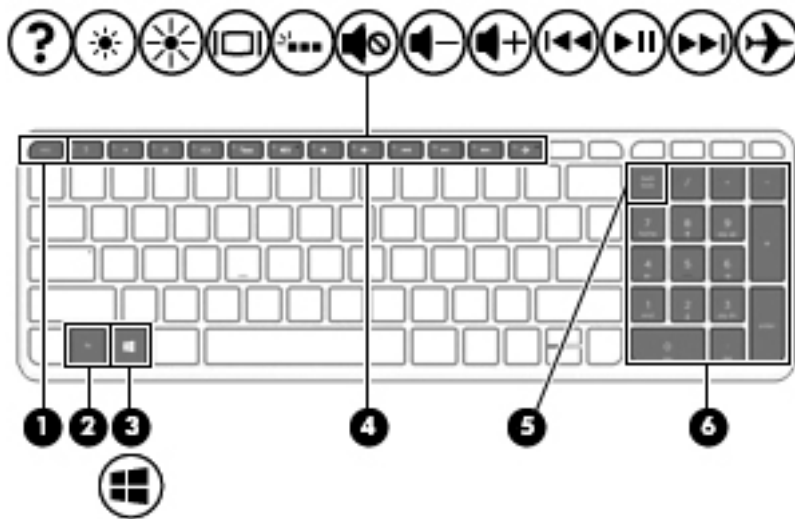

Component	Description
(1) <code>esc</code> key	Displays system information when pressed in combination with the <code>fn</code> key.
(2) <code>fn</code> key	Executes frequently used system functions when pressed in combination with the <code>b</code> or the <code>esc</code> key.
(3)  Windows key	Returns you to the Start screen from an open app or the Windows desktop. <b>NOTE:</b> Pressing the Windows key again will return you to the previous screen.
(4) Action keys	Execute frequently used system functions. <b>NOTE:</b> On select models, the <code>f5</code> action key turns the radiance backlight keyboard feature off or on.
(5) <code>num lk</code> key	Turns the embedded numeric keypad on and off when pressed in combination with the <code>fn</code> key.  Alternates between the navigational and numeric functions on the integrated numeric keypad.
(6) Integrated numeric keypad	When <code>num lk</code> has been enabled, it can be used like an external numeric keypad.

## Bottom

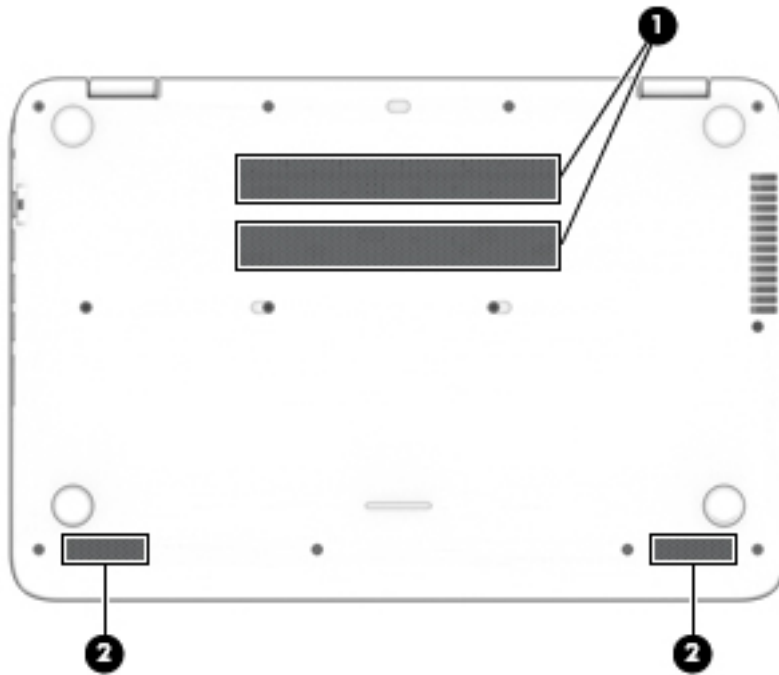

Component	Description
(1) Vents (2)	Enable airflow to cool internal components. <b>NOTE:</b> The computer fan starts up automatically to cool internal components and prevent overheating. It is normal for the internal fan to cycle on and off during routine operation.
(2) Speakers (2)	Produce sound.

# Service tag and PCID label

## Service tag

The labels affixed to the computer provide information you may need when you troubleshoot system problems or travel internationally with the computer.

 **IMPORTANT:** All labels described in this section will be located in one of 3 places depending on your computer model: affixed to the bottom of the computer, located in the battery bay, or under the service door.

- Service label—Provides important information to identify your computer. When contacting support, you will probably be asked for the serial number, and possibly for the product number or the model number. Locate these numbers before you contact support.

Your service label will resemble one of the examples shown below. Refer to the illustration that most closely matches the service label on your computer.

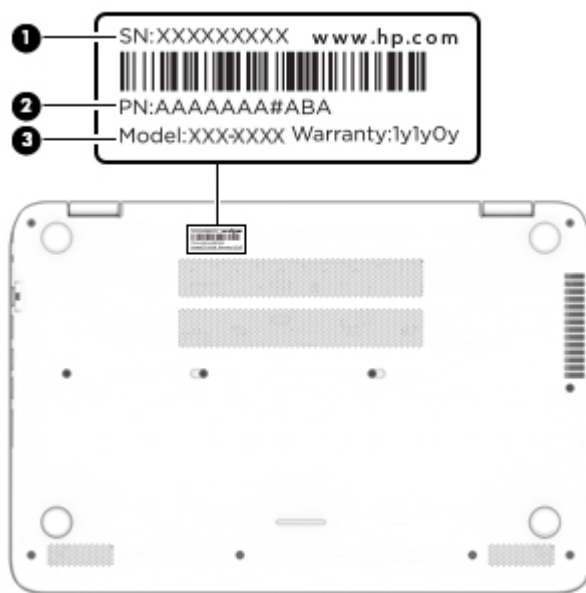

---

### Component

---

- |     |                                  |
|-----|----------------------------------|
| (1) | Serial number                    |
| (2) | Product number                   |
| (3) | Model number and warranty period |
- 

- Microsoft® Certificate of Authenticity label (select models only prior to Windows 8)—Contains the Windows Product Key. You may need the Product Key to update or troubleshoot the operating system. HP platforms preinstalled with Windows 8 or Windows 8.1 do not have the physical label, but have a Digital Product Key electronically installed.

 **NOTE:** This Digital Product Key is automatically recognized and activated by Microsoft Operating Systems on a reinstall of the Windows 8 or Windows 8.1 operating system with HP approved recovery methods.

- Regulatory label(s)—Provide(s) regulatory information about the computer.
- Wireless certification label(s)—Provide(s) information about optional wireless devices and the approval markings for the countries or regions in which the devices have been approved for use.

## PCID label

The PCID label provides the information required to properly reset the notebook firmware (BIOS) back to factory shipped specifications when replacing the system board. The label may have a different number of characters depending on the operating system on the computer.

### Windows 8 models



### Non-Windows 8 models

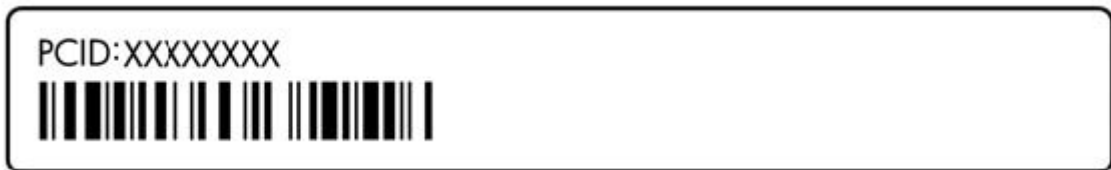

# 3 Illustrated parts catalog

## Computer major components

 **NOTE:** HP continually improves and changes product parts. For complete and current information on supported parts for your computer, go to <http://partsurfer.hp.com>, select your country or region, and then follow the on-screen instructions.

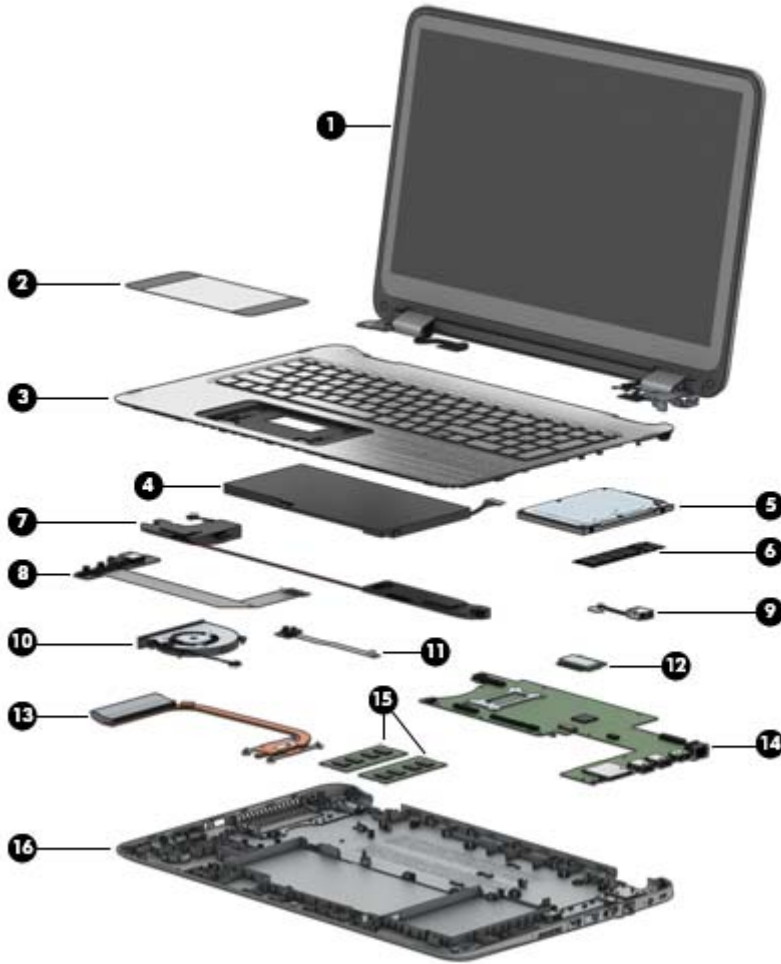

Item	Component	Spare part number
(1)	<b>Display assembly</b>	not spared
(2)	<b>TouchPad board</b> (includes cable)	774598-001
(3)	<b>Top cover</b> (includes keyboard)	
	For use in Belgium	774608-A41
	For use in Bulgaria	774608-261
	For use in Canada (English)	774608-DB1

<b>Item</b>	<b>Component</b>	<b>Spare part number</b>
	For use in the Czech Republic and Slovakia	774608-FL1
	For use in France	774608-051
	For use in Germany	774608-041
	For use in Greece	774608-151
	For use in Hungary	774608-211
	For use in Israel	774608-BB1
	For use in Italy	774608-061
	For use in the Netherlands	774608-DH1
	For use in the Netherlands and Europe	774608-B31
	For use in Romania	774608-271
	For use in Russia	774608-251
	For use in Saudi Arabia	774608-171
	For use in Slovenia	774608-BA1
	For use in Spain	774608-071
	For use in Switzerland	774608-BG1
	For use in Turkey	774608-141
	For use in the United Kingdom	774608-031
	For use in the United States	774608-001
<b>(4)</b>	<b>Battery</b> , 3-cell, 43-Wh, 2.83-Ah, Li-ion	761230-005
<b>(5)</b>	<b>Hard drive</b> (does not include hard drive bracket or hard drive connector cable):	
	1-TB, 5400-rpm, 7.0-mm	762990-005
	750-GB, 5400-rpm, 7.0-mm	752099-005
	500-GB, 5400-rpm, 7.0-mm	778186-005
	500-GB, 5400-rpm, 8 GB hybrid SSD, 7.0-mm	732000-005
	<b>Hard Drive Hardware Kit</b> (not illustrated, includes hard drive bracket and hard drive connector cable)	768020-001
<b>(6)</b>	<b>Solid-state drive</b>	
	256-GB, TLC	777651-001
	256-GB, MLC	777652-001
	<b>Solid-state Drive Hardware Kit</b> (not illustrated; includes cable, bracket, and screws)	777653-001
<b>(7)</b>	<b>Speaker Kit</b> (includes left and right speakers and cable)	774605-001
<b>(8)</b>	<b>USB/audio board</b> (includes cable)	774600-001
<b>(9)</b>	<b>Power connector cable</b>	768012-001
<b>(10)</b>	<b>Fan</b>	778793-001
<b>(11)</b>	<b>Power button board</b> (includes cable)	774599-001



Item	Component	Spare part number
<b>(12)</b>	<b>WLAN module:</b>	
	Intel Dual Band Wireless-AC 7260 802.11 ac 2x2 WiFi + BT 4.0 Combo Adapter	756753-005
	Qualcomm QCA9565 802.11bgn 1x1 Wi-Fi + BT4.0 Combo Adapter	733476-005
	Intel Dual Band Wireless-AC 3160 802.11 ac 1x1 WiFi + BT 4.0 combo adapter	710662-005
	Broadcom BCM43142 802.11 bgn 1x1 Wi-Fi + BT4.0 HMC Combo Adapter	753076-005
	Intel Dual Band Wireless-AC 3160 802.11 ac 1x1 WiFi + Bluetooth 4.0 Combo Adapter	784638-005
	Intel Dual Band Wireless-AC 7260 802.11 ac 2x2 WiFi + BT 4.0 Combo Adapter	784650-005
<b>(13)</b>	<b>Heat sink</b> (includes replacement thermal material)	774595-001
<b>(14)</b>	<b>System board</b> (includes replacement thermal material):	
	Equipped with an Intel Core i7-5500U processor and the Windows 8.1 Standard operating system	782305-501
	Equipped with an Intel Core i7-5500U processor and a non-Windows 8 operating system	782305-001
	Equipped with an Intel Core i7-4510U processor and the Windows 8.1 Standard operating system	780958-501
	Equipped with an Intel Core i7-4510U processor and a non-Windows 8 operating system	780958-001
	Equipped with an Intel Core i5-5200U processor and the Windows 8.1 Standard operating system	782306-501
	Equipped with an Intel Core i5-5200U processor and a non-Windows 8 operating system	782306-001
	Equipped with an Intel Core i5-4210U processor and the Windows 8.1 Standard operating system	774606-501
	Equipped with an Intel Core i5-4210U processor and a non-Windows 8 operating system	774606-001
	Equipped with an Intel Core i3-5010U processor and the Windows 8.1 Standard operating system	802987-501
	Equipped with an Intel Core i3-5010U processor and a non-Windows 8 operating system	802987-001
	Equipped with an Intel Core i3-5005U processor and the Windows 8.1 Standard operating system	782307-501
	Equipped with an Intel Core i3-5005U processor and a non-Windows 8 operating system	782307-001
	Equipped with an Intel Core i3-4030U processor and the Windows 8.1 Standard operating system	774607-501
	Equipped with an Intel Core i3-4030U processor and a non-Windows 8 operating system	774607-001
<b>(15)</b>	<b>Memory module</b> (PC3L, 12800, 1600-MHz):	
	8-GB	693374-005
	4-GB	691740-005
	2-GB	691739-005
<b>(16)</b>	<b>Base enclosure</b>	
	For use in models in North America	
	<ul style="list-style-type: none"> <li>For use in models in North America with the following WLAN module: Qualcomm QCA9565 802.11bgn 1x1 Wi-Fi + BT4.0 Combo Adapter in North America</li> </ul>	774592-001

<b>Item</b>	<b>Component</b>	<b>Spare part number</b>
	<ul style="list-style-type: none"> <li>For use in models in North America with the following WLAN module: Intel Dual Band Wireless-AC 7260 802.11 ac 2x2 WiFi + BT 4.0 Combo Adapter</li> </ul>	784134-001
	<ul style="list-style-type: none"> <li>For use in models in North America with the following WLAN module: Intel Dual Band Wireless-AC 3160 802.11 ac 1x1 WiFi + BT 4.0 Combo Adapter</li> </ul>	785744-001
	<ul style="list-style-type: none"> <li>For use in models in North America with the following WLAN module: Broadcom BCM43142 802.11 bgn 1x1 Wi-Fi + BT4.0 Combo Adapter</li> </ul>	792722-001
	For use in models in EMEA	
	<ul style="list-style-type: none"> <li>For use in models in EMEA with the following WLAN module: Intel Dual Band Wireless-AC 7260 802.11 ac 2x2 WiFi + BT 4.0 Combo Adapter</li> </ul>	784135-001
	<ul style="list-style-type: none"> <li>For use in models in EMEA with the following WLAN module: Intel Dual Band Wireless-AC 3160 802.11 ac 1x1 WiFi + BT 4.0 Combo Adapter</li> </ul>	785745-001
	<ul style="list-style-type: none"> <li>For use in models in EMEA with the following WLAN module: Qualcomm QCA9565 802.11bgn 1x1 Wi-Fi + BT4.0 Combo Adapter in North America</li> </ul>	784133-001
	<ul style="list-style-type: none"> <li>For use in models in EMEA with the following WLAN module: Broadcom BCM43142 802.11 bgn 1x1 Wi-Fi + BT4.0 Combo Adapter</li> </ul>	792723-001

## Display assembly subcomponents

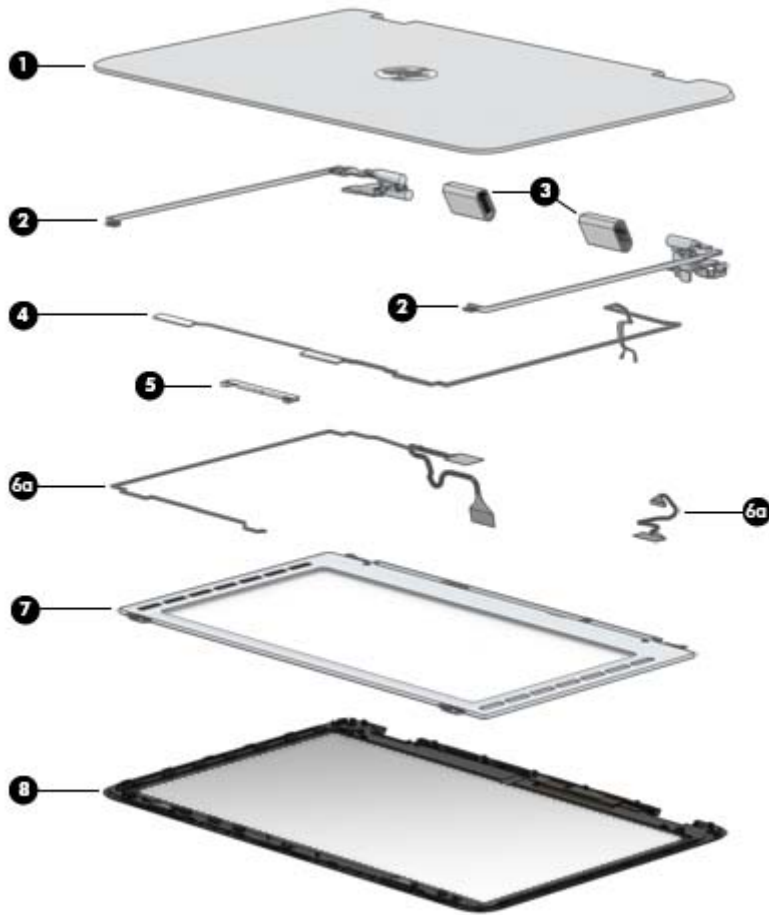

Item	Component	Spare part number
(1)	Display enclosure	774591-001
(2)	Display hinges (includes left and right hinges)	774596-001
(3)	Display hinge covers	774597-001
(4)	Antenna	774590-001
(5)	Webcam	768040-001
	<b>Display cable kit, includes:</b>	
(6a)	Display/webcam cable	
(6b)	Touch cable	
	• HD models	774593-001
	• FHD models	774594-001
	<b>Display panel kit, includes:</b>	
(7)	Bezel/glass	
(8)	Raw display panel	

Item	Component	Spare part number
	Fix bracket, touch control board, and backlight cable (not illustrated)	
	<ul style="list-style-type: none"> <li>• HD models</li> </ul>	774602-001
	<ul style="list-style-type: none"> <li>• FHD models</li> </ul>	774603-001

## Mass storage devices

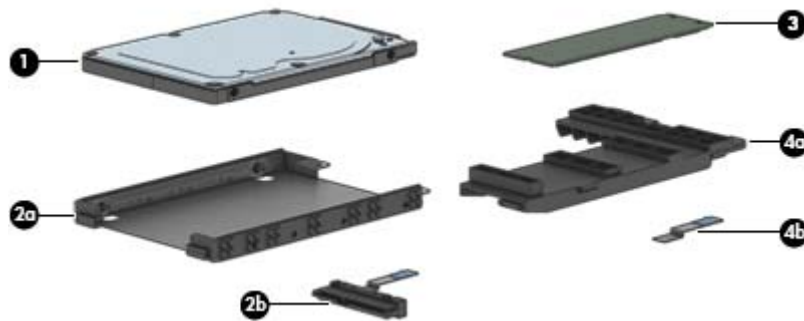

	Component	Spare part number
<b>(1)</b>	<b>Hard drive</b> (does not include hard drive bracket, hard drive connector cable, or screws):	
	1-TB, 5400-rpm, 7.0-mm	762990-005
	750-GB, 5400-rpm, 7.0-mm	752099-005
	500-GB, 5400-rpm, 7.0-mm	778186-005
	500-GB, 5400-rpm, 8 GB hybrid SSD, 7.0-mm	732000-005
	<b>Hard Drive Hardware Kit</b> , includes:	768020-001
<b>(2a)</b>	Hard drive bracket	
<b>(2b)</b>	Hard drive connector cable	
<b>(3)</b>	<b>Solid-state drive</b>	
	256-GB, TLC	777651-001
	256-GB, MLC	777652-001
	<b>Solid-state Drive Hardware Kit</b> , includes:	777653-001
<b>(4a)</b>	Cable	
<b>(4b)</b>	Bracket	
	<b>External DVD±RW Double-Layer with SuperMulti Drive</b> (not illustrated)	747080-001

## Miscellaneous parts

Component	Spare part number
<b>HP Smart AC adapter</b> , 45-W, non-PFC, 4.5-mm, non-slim	741727-001
<b>Power cord</b> (3-pin, black, 1.0-m):	
For use in Europe	755530-021
For use in Israel	755530-BB1
For use in Denmark	755530-081
For use in North America	755530-001
For use in South Africa	755530-AR1
For use in Switzerland	755530-111
For use in the United Kingdom and Singapore	755530-031
<b>Rubber Feet Kit</b>	768019-001
<b>Screw Kit</b>	774604-001
<b>HDMI to VGA adapter</b>	701943-001

## Sequential part number listing

Spare part number	Description
691739-005	2-GB memory module (PC3L, 12800, 1600-MHz)
691740-005	4-GB memory module (PC3L, 12800, 1600-MHz)
693374-005	8-GB memory module (PC3L, 12800, 1600-MHz)
701943-001	HDMI to VGA adapter
710662-005	Intel Dual Band Wireless-AC 3160 802.11 ac 1x1 WiFi + BT 4.0 combo adapter
732000-005	500-GB hard drive, 5400-rpm, 8 GB hybrid SSD, 7.0-mm <b>NOTE:</b> The hard drive bracket and hard drive connector cable are included in the Hard Drive Hardware Kit, spare part number 768020-001.
733476-005	Qualcomm QCA9565 802.11bgn 1x1 Wi-Fi + BT4.0 Combo Adapter
741727-001	45-W HP Smart AC adapter (non-PFC, 4.5-mm, non-slim)
747080-001	External DVD±RW Double-Layer with SuperMulti Drive
752099-005	750-GB hard drive, 5400-rpm, 7.0-mm <b>NOTE:</b> The hard drive bracket and hard drive connector cable are included in the Hard Drive Hardware Kit, spare part number 768020-001.
753076-005	HP hs3110 HSPA+ Mobile Broadband Module
755530-001	Power cord for use in North America (3-pin, black, 1.0-m)
755530-021	Power cord for use in Europe (3-pin, black, 1.0-m)
755530-031	Power cord for use in the United Kingdom and Singapore (3-pin, black, 1.0-m)

Spare part number	Description
755530-081	Power cord for use in Denmark (3-pin, black, 1.0-m)
755530-111	Power cord for use in Switzerland (3-pin, black, 1.0-m)
755530-AR1	Power cord for use in South Africa (3-pin, black, 1.0-m)
755530-BB1	Power cord for use in Israel (3-pin, black, 1.83-m)
756753-005	Intel Dual Band Wireless-AC 7260 802.11 ac 2x2 WiFi + BT 4.0 Combo Adapter
761230-005	3-cell, 43-Wh, 2.83-Ah, Li-ion battery
762990-005	1-TB hard drive, 5400-rpm, 7.0-mm
	<b>NOTE:</b> The hard drive bracket and hard drive connector cable are included in the Hard Drive Hardware Kit, spare part number 768020-001.
768012-001	Power connector cable
768019-001	Rubber Feet Kit
768020-001	Hard Drive Hardware Kit (includes hard drive bracket and hard drive connector cable)
768040-001	Webcam
774590-001	Antenna
774591-001	Display enclosure
774592-001	Base enclosure for use in models in North America with the following WLAN module: Qualcomm QCA9565 802.11bgn 1x1 Wi-Fi + BT4.0 Combo Adapter in North America
774593-001	Display cable for use in HD models
774594-001	Display cable for use in FHD models
774595-001	Heat sink (includes replacement thermal material)
774596-001	Display hinges (includes left and right hinges)
774597-001	Display hinge cover kit
774598-001	Touchpad board
774599-001	Power button board (includes cable)
774600-001	USB/audio board (includes cable)
774602-001	Raw display panel kit for use in HD models (includes bezel, fix bracket, touch control board, and backlight cable)
774603-001	Raw display panel for use in FHD models (includes bezel, fix bracket, touch control board, and backlight cable)
774604-001	Screw Kit
774605-001	Speaker Kit (includes left and right speakers and cable)
774606-001	System board equipped with an Intel Core i5-4210U processor and a non-Windows 8 operating system (includes replacement thermal material)
774606-501	System board equipped with an Intel Core i5-4210U processor and the Windows 8.1 Standard operating system (includes replacement thermal material)
774607-001	System board equipped with an Intel Core i3-4030U processor and a non-Windows 8 operating system (includes replacement thermal material)

Spare part number	Description
774607-501	System board equipped with an Intel Core i3-4030U processor and the Windows 8.1 Standard operating system (includes replacement thermal material)
774608-001	Top cover with keyboard for use in the United States
774608-031	Top cover with keyboard for use in the United Kingdom
774608-041	Top cover with keyboard for use in Germany
774608-051	Top cover with keyboard for use in France
774608-061	Top cover with keyboard for use in Italy
774608-071	Top cover with keyboard for use in Spain
774608-141	Top cover with keyboard for use in Turkey
774608-151	Top cover with keyboard for use in Greece
774608-171	Top cover with keyboard for use in Saudi Arabia
774608-211	Top cover with keyboard for use in Hungary
774608-251	Top cover with keyboard for use in Russia
774608-261	Top cover with keyboard for use in Bulgaria
774608-271	Top cover with keyboard for use in Romania
774608-A41	Top cover with keyboard for use in Belgium
774608-B31	Top cover with keyboard for use in the Netherlands and Europe
774608-BA1	Top cover with keyboard for use in Slovenia
774608-BB1	Top cover with keyboard for use in Israel
774608-BG1	Top cover with keyboard for use in Switzerland
774608-DB1	Top cover with keyboard for use in Canada
774608-DH1	Top cover with keyboard for use in the Netherlands
774608-FL1	Top cover with keyboard for use in the Czech Republic and Slovakia
777651-001	256-GB solid-state drive, TLC
777652-001	256-GB solid-state drive, MLC
777653-001	Solid-state Drive Hardware Kit (includes cable, bracket, and screws)
778186-005	500-GB hard drive, 5400-rpm, SATA, 7.0-mm hard drive <b>NOTE:</b> The hard drive bracket and hard drive connector cable are included in the Hard Drive Hardware Kit, spare part number 768020-001.
778793-001	Fan
780958-001	System board equipped with an Intel Core i7-4510U processor and a non-Windows 8 operating system (includes replacement thermal material)
780958-501	System board equipped with an Intel Core i7-4510U processor and the Windows 8.1 Standard operating system (includes replacement thermal material)
782305-001	System board equipped with an Intel Core i7-5500U processor and a non-Windows 8 operating system (includes replacement thermal material)

<b>Spare part number</b>	<b>Description</b>
782305-501	System board equipped with an Intel Core i7-5500U processor and the Windows 8.1 Standard operating system (includes replacement thermal material)
782306-001	System board equipped with an Intel Core i5-5200U processor and a non-Windows 8 operating system (includes replacement thermal material)
782306-501	System board equipped with an Intel Core i5-5200U processor and the Windows 8.1 Standard operating system (includes replacement thermal material)
782307-001	System board equipped with an Intel Core i3-5005U processor and a non-Windows 8 operating system (includes replacement thermal material)
782307-501	System board equipped with an Intel Core i3-5005U processor and the Windows 8.1 Standard operating system (includes replacement thermal material)
784133-001	Base enclosure for use in models in EMEA with the following WLAN module: Qualcomm QCA9565 802.11bgn 1x1 Wi-Fi + BT4.0 Combo Adapter in North America
784134-001	Base enclosure for use in models in North America with the following WLAN module: Intel Dual Band Wireless-AC 7260 802.11 ac 2x2 WiFi + BT 4.0 Combo Adapter
784135-001	Base enclosure for use in models in EMEA with the following WLAN module: Intel Dual Band Wireless-AC 7260 802.11 ac 2x2 WiFi + BT 4.0 Combo Adapter
784638-005	Intel Dual Band Wireless-AC 3160 802.11 ac 1x1 WiFi + Bluetooth 4.0 Combo Adapter
784650-005	Intel Dual Band Wireless-AC 7260 802.11 ac 2x2 WiFi + BT 4.0 Combo Adapter
785744-001	Base enclosure for use in models in North America with the following WLAN module: Intel Dual Band Wireless-AC 3160 802.11 ac 1x1 WiFi + BT 4.0 Combo Adapter
785745-001	Base enclosure for use in models in EMEA with the following WLAN module: Intel Dual Band Wireless-AC 3160 802.11 ac 1x1 WiFi + BT 4.0 Combo Adapter
792722-001	Base enclosure for use in models in North America with the following WLAN module: Broadcom BCM43142 802.11 bgn 1x1 Wi-Fi + BT4.0 Combo Adapter
792723-001	Base enclosure for use in models in EMEA with the following WLAN module: Broadcom BCM43142 802.11 bgn 1x1 Wi-Fi + BT4.0 Combo Adapter
802987-001	System board equipped with an Intel Core i3-5010U processor and a non-Windows 8 operating system (includes replacement thermal material)
802987-501	System board equipped with an Intel Core i3-5010U processor and the Windows 8.1 Standard operating system (includes replacement thermal material)



---

# 4 Removal and replacement procedures preliminary requirements

## Tools required

You will need the following tools to complete the removal and replacement procedures:

- Flat-bladed screw driver
- Magnetic screw driver
- Phillips P0 and P1 screw drivers

## Service considerations

The following sections include some of the considerations that you must keep in mind during disassembly and assembly procedures.

---

 **NOTE:** As you remove each subassembly from the computer, place the subassembly (and all accompanying screws) away from the work area to prevent damage.

---

## Plastic parts

---

 **CAUTION:** Using excessive force during disassembly and reassembly can damage plastic parts. Use care when handling the plastic parts. Apply pressure only at the points designated in the maintenance instructions.

---

## Cables and connectors

---

 **CAUTION:** When servicing the computer, be sure that cables are placed in their proper locations during the reassembly process. Improper cable placement can damage the computer.

---

Cables must be handled with extreme care to avoid damage. Apply only the tension required to unseat or seat the cables during removal and insertion. Handle cables by the connector whenever possible. In all cases, avoid bending, twisting, or tearing cables. Be sure that cables are routed in such a way that they cannot be caught or snagged by parts being removed or replaced. Handle flex cables with extreme care; these cables tear easily.

## Drive handling

---

**⚠ CAUTION:** Drives are fragile components that must be handled with care. To prevent damage to the computer, damage to a drive, or loss of information, observe these precautions:

Before removing or inserting a hard drive, shut down the computer. If you are unsure whether the computer is off or in Hibernation, turn the computer on, and then shut it down through the operating system.

Before handling a drive, be sure that you are discharged of static electricity. While handling a drive, avoid touching the connector.

Before removing a diskette drive or optical drive, be sure that a diskette or disc is not in the drive and be sure that the optical drive tray is closed.

Handle drives on surfaces covered with at least one inch of shock-proof foam.

Avoid dropping drives from any height onto any surface.

After removing a hard drive, an optical drive, or a diskette drive, place it in a static-proof bag.

Avoid exposing an internal hard drive to products that have magnetic fields, such as monitors or speakers.

Avoid exposing a drive to temperature extremes or liquids.

If a drive must be mailed, place the drive in a bubble pack mailer or other suitable form of protective packaging and label the package “FRAGILE.”

---

## Grounding guidelines

### Electrostatic discharge damage

Electronic components are sensitive to electrostatic discharge (ESD). Circuitry design and structure determine the degree of sensitivity. Networks built into many integrated circuits provide some protection, but in many cases, ESD contains enough power to alter device parameters or melt silicon junctions.

A discharge of static electricity from a finger or other conductor can destroy static-sensitive devices or microcircuitry. Even if the spark is neither felt nor heard, damage may have occurred.

An electronic device exposed to ESD may not be affected at all and can work perfectly throughout a normal cycle. Or the device may function normally for a while, then degrade in the internal layers, reducing its life expectancy.

---

**⚠ CAUTION:** To prevent damage to the computer when you are removing or installing internal components, observe these precautions:

Keep components in their electrostatic-safe containers until you are ready to install them.

Before touching an electronic component, discharge static electricity by using the guidelines described in this section.

Avoid touching pins, leads, and circuitry. Handle electronic components as little as possible.

If you remove a component, place it in an electrostatic-safe container.

---

The following table shows how humidity affects the electrostatic voltage levels generated by different activities.

---

**⚠ CAUTION:** A product can be degraded by as little as 700 V.

---

Typical electrostatic voltage levels			
Event	Relative humidity		
	10%	40%	55%
Walking across carpet	35,000 V	15,000 V	7,500 V
Walking across vinyl floor	12,000 V	5,000 V	3,000 V
Motions of bench worker	6,000 V	800 V	400 V
Removing DIPS from plastic tube	2,000 V	700 V	400 V
Removing DIPS from vinyl tray	11,500 V	4,000 V	2,000 V
Removing DIPS from Styrofoam	14,500 V	5,000 V	3,500 V
Removing bubble pack from PCB	26,500 V	20,000 V	7,000 V
Packing PCBs in foam-lined box	21,000 V	11,000 V	5,000 V

## Packaging and transporting guidelines

Follow these grounding guidelines when packaging and transporting equipment:

- To avoid hand contact, transport products in static-safe tubes, bags, or boxes.
- Protect ESD-sensitive parts and assemblies with conductive or approved containers or packaging.
- Keep ESD-sensitive parts in their containers until the parts arrive at static-free workstations.
- Place items on a grounded surface before removing items from their containers.
- Always be properly grounded when touching a component or assembly.
- Store reusable ESD-sensitive parts from assemblies in protective packaging or nonconductive foam.
- Use transporters and conveyors made of antistatic belts and roller bushings. Be sure that mechanized equipment used for moving materials is wired to ground and that proper materials are selected to avoid static charging. When grounding is not possible, use an ionizer to dissipate electric charges.

## Workstation guidelines

Follow these grounding workstation guidelines:

- Cover the workstation with approved static-shielding material.
- Use a wrist strap connected to a properly grounded work surface and use properly grounded tools and equipment.
- Use conductive field service tools, such as cutters, screw drivers, and vacuums.
- When fixtures must directly contact dissipative surfaces, use fixtures made only of static-safe materials.
- Keep the work area free of nonconductive materials, such as ordinary plastic assembly aids and Styrofoam.
- Handle ESD-sensitive components, parts, and assemblies by the case or PCM laminate. Handle these items only at static-free workstations.

- Avoid contact with pins, leads, or circuitry.
- Turn off power and input signals before inserting or removing connectors or test equipment.

### Equipment guidelines

Grounding equipment must include either a wrist strap or a foot strap at a grounded workstation.

- When seated, wear a wrist strap connected to a grounded system. Wrist straps are flexible straps with a minimum of one megohm  $\pm 10\%$  resistance in the ground cords. To provide proper ground, wear a strap snugly against the skin at all times. On grounded mats with banana-plug connectors, use alligator clips to connect a wrist strap.
- When standing, use foot straps and a grounded floor mat. Foot straps (heel, toe, or boot straps) can be used at standing workstations and are compatible with most types of shoes or boots. On conductive floors or dissipative floor mats, use foot straps on both feet with a minimum of one megohm resistance between the operator and ground. To be effective, the conductive must be worn in contact with the skin.

The following grounding equipment is recommended to prevent electrostatic damage:

- Antistatic tape
- Antistatic smocks, aprons, and sleeve protectors
- Conductive bins and other assembly or soldering aids
- Nonconductive foam
- Conductive tabletop workstations with ground cords of one megohm resistance
- Static-dissipative tables or floor mats with hard ties to the ground
- Field service kits
- Static awareness labels
- Material-handling packages
- Nonconductive plastic bags, tubes, or boxes
- Metal tote boxes
- Electrostatic voltage levels and protective materials

The following table lists the shielding protection provided by antistatic bags and floor mats.

Material	Use	Voltage protection level
Antistatic plastics	Bags	1,500 V
Carbon-loaded plastic	Floor mats	7,500 V
Metallized laminate	Floor mats	5,000 V

---

# 5 Removal and replacement procedures for Authorized Service Provider parts

---

 **CAUTION:** Components described in this chapter should only be accessed by an authorized service provider. Accessing these parts can damage the computer or void the warranty.

 **NOTE:** HP continually improves and changes product parts. For complete and current information on supported parts for your computer, go to <http://partsurfer.hp.com>, select your country or region, and then follow the on-screen instructions.

---

## Component replacement procedures

This chapter provides removal and replacement procedures for Authorized Service Provider only parts.

There are as many as 76 screws that must be removed, replaced, and/or loosened when servicing the computer. Make special note of each screw size and location during removal and replacement.

## Top cover

Description	Spare part number
Top cover with keyboard for use in Belgium	774608-A41
Top cover with keyboard for use in Bulgaria	774608-261
Top cover with keyboard for use in Canada (English)	774608-DB1
Top cover with keyboard for use in the Czech Republic and Slovakia	774608-FL1
Top cover with keyboard for use in France	774608-051
Top cover with keyboard for use in Germany	774608-041
Top cover with keyboard for use in Greece	774608-151
Top cover with keyboard for use in Hungary	774608-211
Top cover with keyboard for use in Israel	774608-BB1
Top cover with keyboard for use in Italy	774608-061
Top cover with keyboard for use in the Netherlands	774608-DH1
Top cover with keyboard for use in the Netherlands and Europe	774608-B31
Top cover with keyboard for use in Romania	774608-271
Top cover with keyboard for use in Russia	774608-251
Top cover with keyboard for use in Saudi Arabia	774608-171
Top cover with keyboard for use in Slovenia	774608-BA1
Top cover with keyboard for use in Spain	774608-071
Top cover with keyboard for use in Switzerland	774608-BG1
Top cover with keyboard for use in Turkey	774608-141
Top cover with keyboard for use in the United Kingdom	774608-031
Top cover with keyboard for use in the United States	774608-001

Before removing the top cover, follow these steps:

1. Turn off the computer. If you are unsure whether the computer is off or in Hibernation, turn the computer on, and then shut it down through the operating system.
2. Disconnect the power from the computer by unplugging the power cord from the computer.
3. Disconnect all external devices from the computer.

Remove the top cover:

1. Position the computer upside-down.

2. Pry the two rear rubber feet off the top cover.

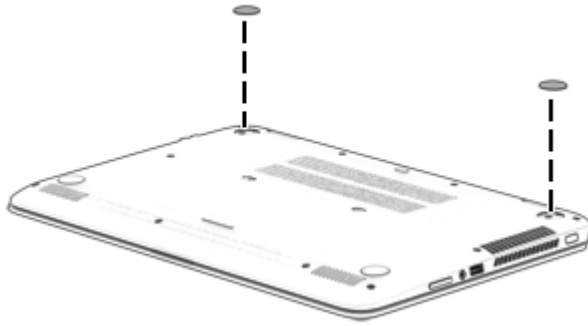

3. Remove the 12 Phillips PM2.5×6.0 screws (1) that secure the top cover to the computer.

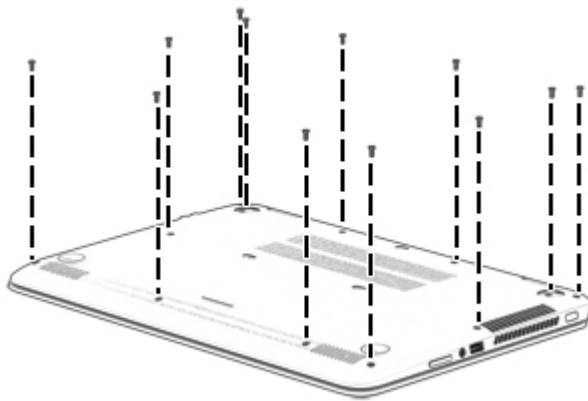

4. Separate the top cover from the computer by lifting up on the front of the top cover (starting near the touchpad) (1), and then lifting the cover up and off the computer (2) far enough to access the keyboard and touchpad cables on the system board.

 **NOTE:** When you lift the top cover, cables are connected from the keyboard and touchpad (installed on the inside of the top cover) to the system board. Be sure not to pull the cables loose when lifting the top cover.

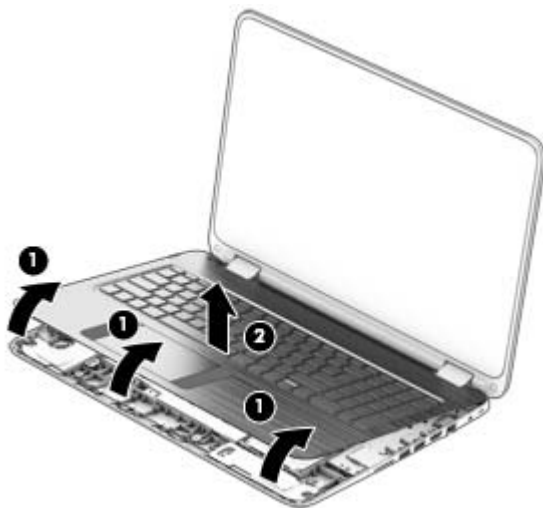

5. Disconnect the keyboard cable **(1)** and the touchpad cable **(2)** from the system board.

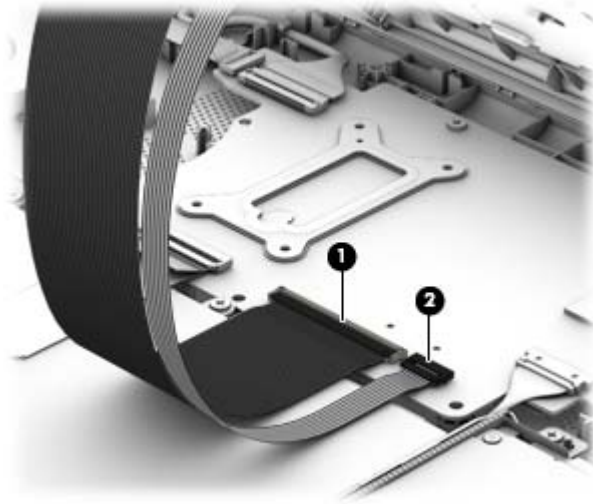

6. Remove the top cover from the computer.  
Reverse this procedure to install the top cover.



## Battery



**NOTE:** You do not have to remove the battery to remove most computer components. Be sure to disconnect the battery cable from the system board before removing any components.

Description	Spare part number
3-cell, 43-Wh, 2.83-Ah, Li-ion battery	761230-005

Before removing the battery, follow these steps:

1. Turn off the computer. If you are unsure whether the computer is off or in Hibernation, turn the computer on, and then shut it down through the operating system.
2. Disconnect the power from the computer by unplugging the power cord from the computer.
3. Disconnect all external devices from the computer.
4. Remove the top cover (see [Top cover on page 30](#)).
5. Disconnect the battery.

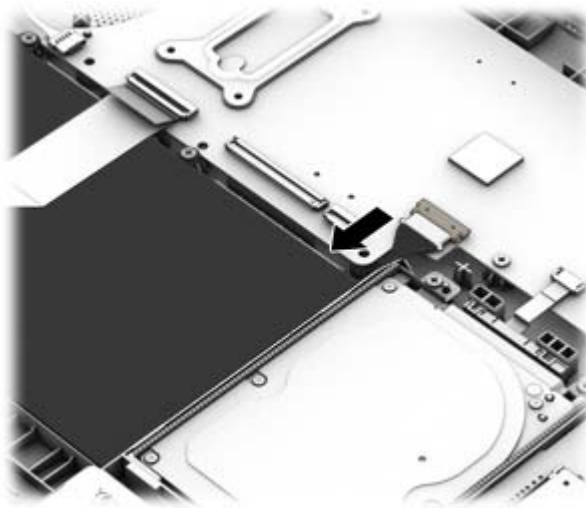

Remove the battery:



**WARNING!** To reduce potential safety issues, use only the battery provided with the computer, a replacement battery provided by HP, or a compatible battery purchased from HP.

1. Remove the three Phillips PM2.5×4.0 screws **(1)** that secure the battery to the computer.

2. Remove the battery (2).

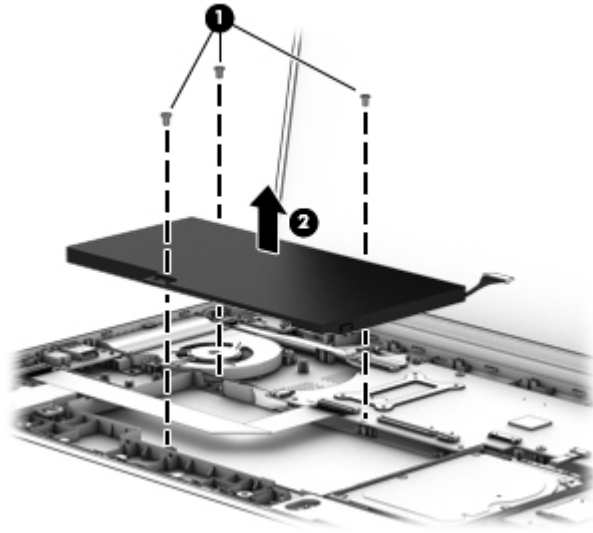

Reverse this procedure to install the battery.

## TouchPad board

Description	Spare part number
Touchpad board (includes cable)	774598-001

Before removing the touchpad board, follow these steps:

1. Turn off the computer. If you are unsure whether the computer is off or in Hibernation, turn the computer on, and then shut it down through the operating system.
2. Disconnect the power from the computer by unplugging the power cord from the computer.
3. Disconnect all external devices from the computer.
4. Remove the top cover (see [Top cover on page 30](#)).

Remove the touchpad board:

1. Position the top cover upside-down.
2. Remove the three Phillips PM2.0×2.0 broadhead screws **(1)** that secure the TouchPad board to the computer.
3. Lift to disengage the cable from the adhesive securing it to the computer **(2)**.
4. Separate the touchpad board from the top cover by pulling it downward away from the top cover **(3)**.

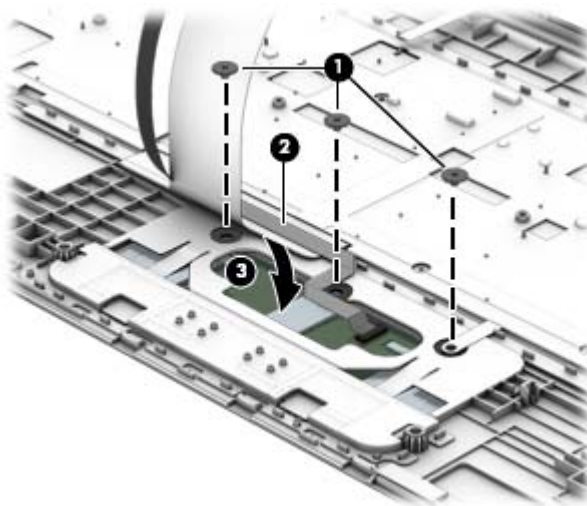

Reverse this procedure to install the touchpad board.

## Hard drive



**NOTE:** The hard drive spare part kit does not include the hard drive bracket and hard drive connector cable. These components are included in the Hard Drive Hardware Kit, spare part number 768020-001.

Description	Spare part number
500-GB, 5400-rpm, 7.0-mm hard drive	778186-005
500-GB, 5400-rpm, 8 GB hybrid SSD, 7.0-mm hard drive	732000-005
Hard Drive Hardware Kit (includes cable, bracket, and screws)	768020-001

Before removing the hard drive, follow these steps:

1. Turn off the computer. If you are unsure whether the computer is off or in Hibernation, turn the computer on, and then shut it down through the operating system.
2. Disconnect the power from the computer by unplugging the power cord from the computer.
3. Disconnect all external devices from the computer.
4. Remove the top cover (see [Top cover on page 30](#)).
5. Disconnect the battery.

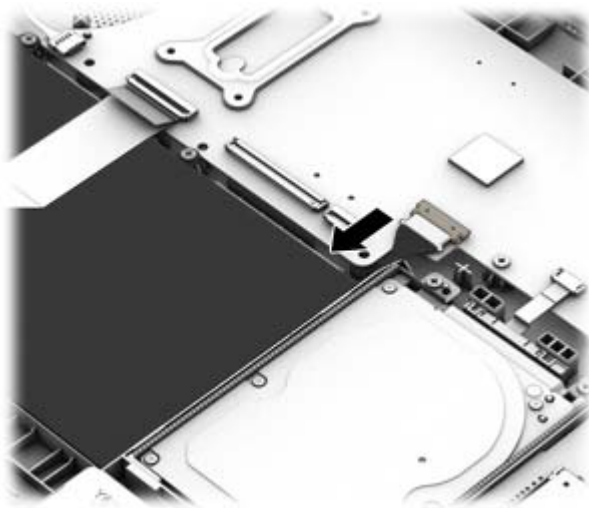

Remove the hard drive:

1. Disconnect the cable **(1)** from the system board.
2. Remove the two Phillips PM2.5×4.0 screws **(2)** that secure the hard drive to the computer.

3. Lift the hard drive out of the computer **(3)**.

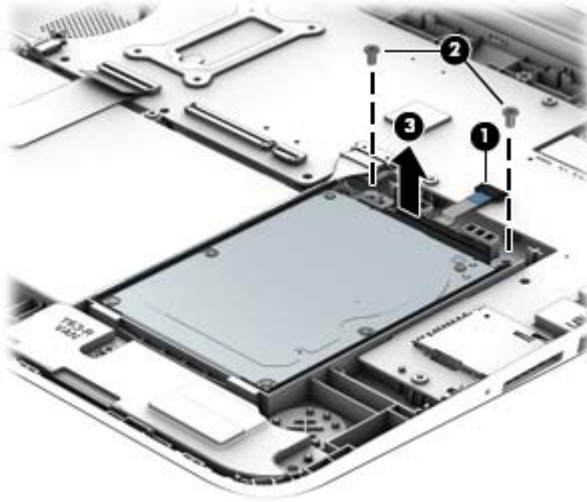

4. If it is necessary to disassemble the hard drive, perform the following steps:
  - a. Disconnect the hard drive connector cable **(1)** from the hard drive.
  - b. Flex the sides of the bracket to remove the pegs from the holes in the hard drive **(2)**.
  - c. Remove the hard drive bracket **(3)** from the hard drive.

The hard drive bracket and hard drive connector cable are available in the Hard Drive Hardware Kit, spare part number 768020-001.

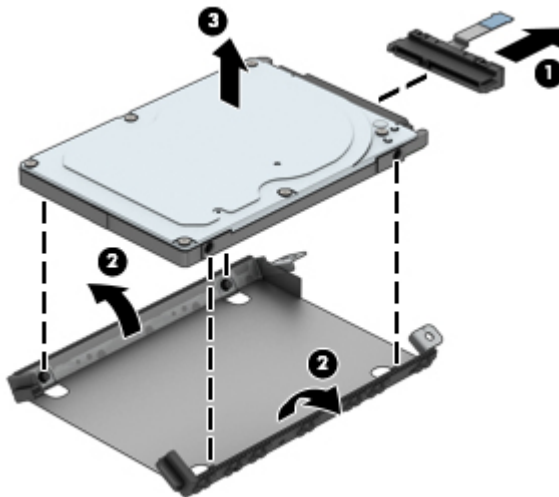

Reverse this procedure to install the hard drive.

## Solid-state drive (SSD)

 **NOTE:** The solid-state drive spare part kit does not include the cable, bracket, or screws. These components are included in the Solid-state Drive Hardware Kit, spare part number 777653-001.

Description	Spare part number
256-GB solid-state drive, TLC	777651-001
256-GB solid-state drive, MLC	777652-001
Solid-state Drive Hardware Kit (includes cable, bracket, and screws)	777653-001

Before removing the solid-state drive, follow these steps:

1. Turn off the computer. If you are unsure whether the computer is off or in Hibernation, turn the computer on, and then shut it down through the operating system.
2. Disconnect the power from the computer by unplugging the power cord from the computer.
3. Disconnect all external devices from the computer.
4. Remove the top cover (see [Top cover on page 30](#)).
5. Disconnect the battery.

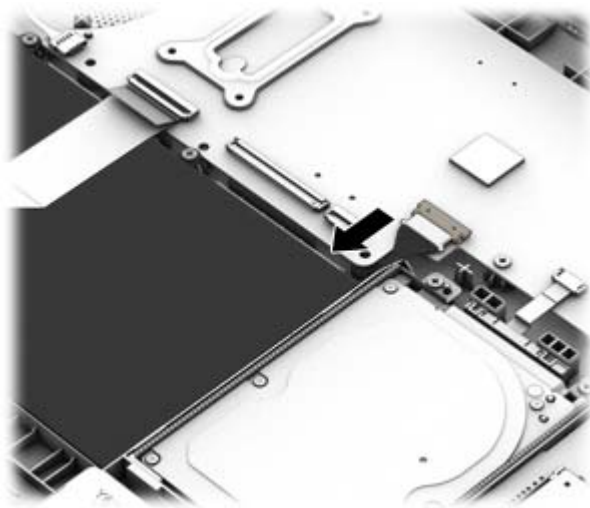

Remove the solid-state drive:

1. Disconnect the cable **(1)** from the system board.
2. Remove the two Phillips PM2.5×4.0 screws **(2)** that secure the solid-state drive bracket to the computer.

3. Lift the solid-state drive assembly out of the computer (3).

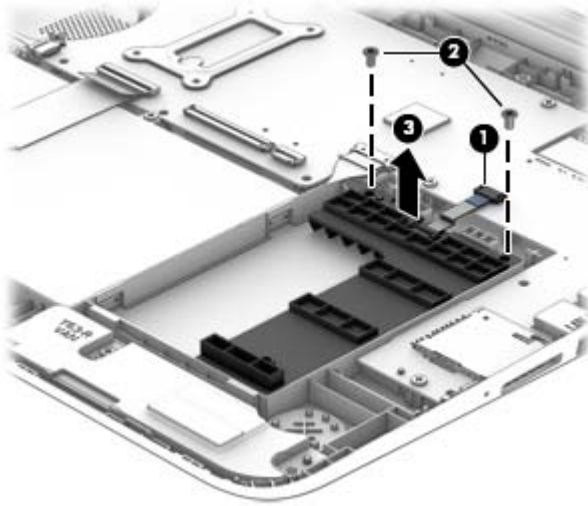

4. If it is necessary to disassemble the solid-state drive, perform the following steps:
  - a. Disconnect the cable (1) from the drive.
  - b. Remove the Phillips PM2.5×4.0 screw (2) that secures the solid-state drive to the bracket.
  - c. Lift the top of the drive upward enough to remove it from the bracket (3).
  - d. Pull the drive up and away from the bracket (4) to disconnect it from the connector in the bracket (5).

The solid-state drive bracket and connector cable are available in the Solid-state Drive Hardware Kit, spare part number 777653-001.

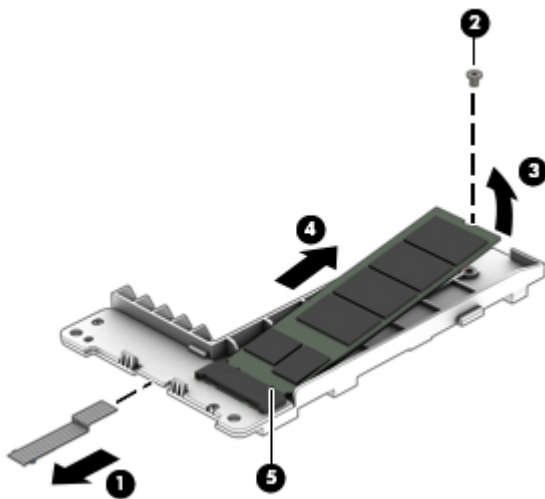

Reverse this procedure to install the solid-state drive.

## WLAN module

Description	Spare part number
Intel Dual Band Wireless-AC 7260 802.11 ac 2x2 WiFi + BT 4.0 Combo Adapter	756753-005
Qualcomm QCA9565 802.11 bgn 1x1 Wi-Fi + BT4.0 Combo Adapter	733476-005
Intel Dual Band Wireless-AC 3160 802.11 ac 1x1 WiFi + BT 4.0 combo adapter	710662-005
Broadcom BCM43142 802.11 bgn 1x1 Wi-Fi + BT4.0 HMC Combo Adapter	753076-005
Intel Dual Band Wireless-AC 3160 802.11 ac 1x1 WiFi + Bluetooth 4.0 Combo Adapter	784638-005
Intel Dual Band Wireless-AC 7260 802.11 ac 2x2 WiFi + BT 4.0 Combo Adapter	784650-005

**CAUTION:** To prevent an unresponsive system, replace the wireless module only with a wireless module authorized for use in the computer by the governmental agency that regulates wireless devices in your country or region. If you replace the module and then receive a warning message, remove the module to restore device functionality, and then contact technical support.

Before removing the WLAN module, follow these steps:

1. Turn off the computer. If you are unsure whether the computer is off or in Hibernation, turn the computer on, and then shut it down through the operating system.
2. Disconnect the power from the computer by unplugging the power cord from the computer.
3. Disconnect all external devices from the computer.
4. Remove the top cover (see [Top cover on page 30](#)).
5. Disconnect the battery.

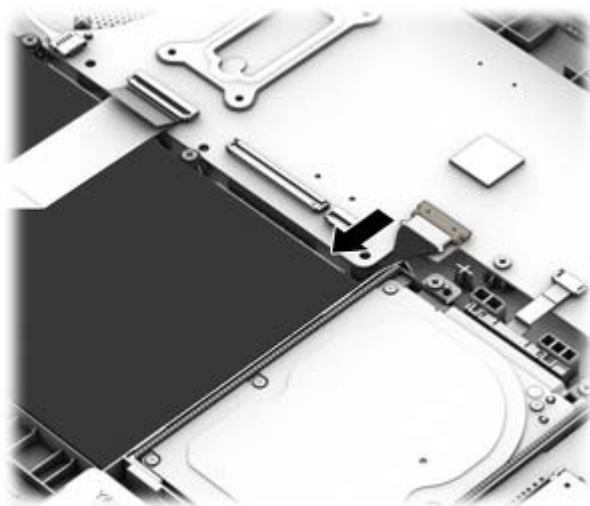

Remove the WLAN module:

1. Disconnect the WLAN antenna cables (**1**) from the terminal on the WLAN module.



 **NOTE:** The WLAN antenna cable labeled “1” connects to the WLAN module “Main” terminal labeled “1”. The WLAN antenna cable labeled “2” connects to the WLAN module “Aux” terminal labeled “2”. If the computer is equipped with an 802.11a/b/g/n WLAN module, the yellow WLAN antenna cable connects to the middle terminal on the WLAN module.

2. Remove the Phillips PM2.0×3.0 screw (2) that secures the WLAN module to the system board. (The WLAN module tilts up.)
3. Remove the WLAN module (3) by pulling the module away from the slot at an angle.

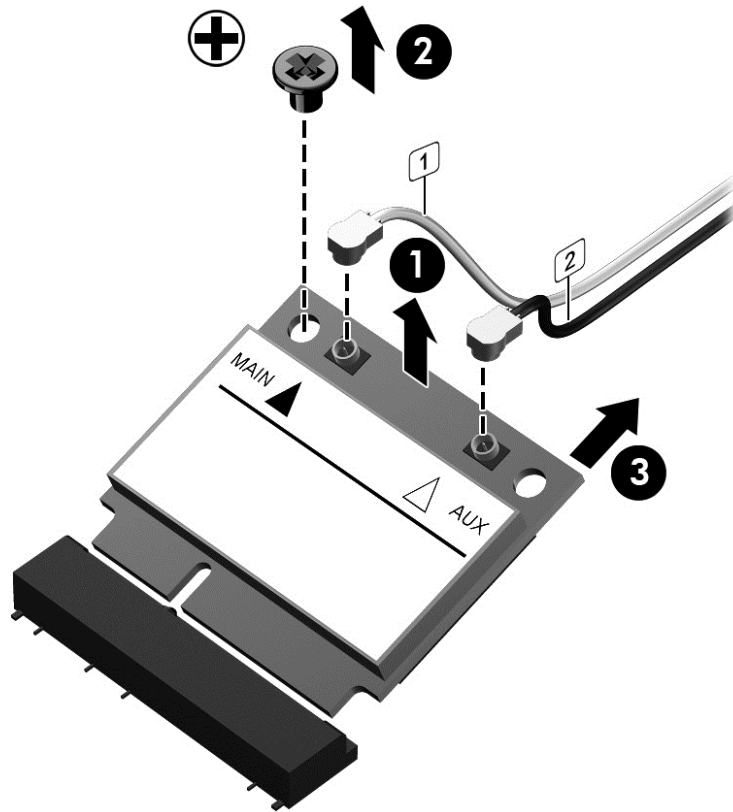

 **NOTE:** If the WLAN antenna cables are not connected to the terminals on the WLAN module, the protective sleeves must be installed on the antenna connectors, as shown in the following illustration.



Reverse this procedure to install the WLAN module.

## Speakers

Description	Spare part number
Speaker Kit (includes left and right speakers and cable)	774605-001

Before removing the speakers, follow these steps:

1. Turn off the computer. If you are unsure whether the computer is off or in Hibernation, turn the computer on, and then shut it down through the operating system.
2. Disconnect the power from the computer by unplugging the power cord from the computer.
3. Disconnect all external devices from the computer.
4. Remove the top cover (see [Top cover on page 30](#)).
5. Disconnect the battery.

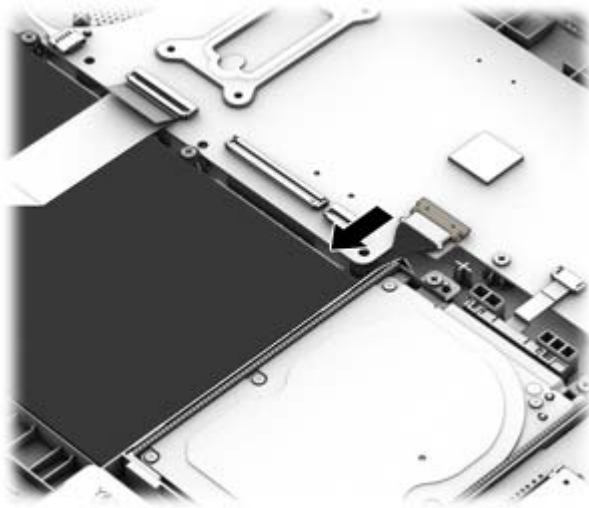

Remove the speakers:

1. Disconnect the speaker cable from the system board **(1)**.
2. Remove the cable from clips built into chassis **(2)**.
3. Remove the two Phillips PM2.5×4.0 screws **(3)** that secure the speakers to the computer.

4. Remove the speakers **(4)** from the computer.

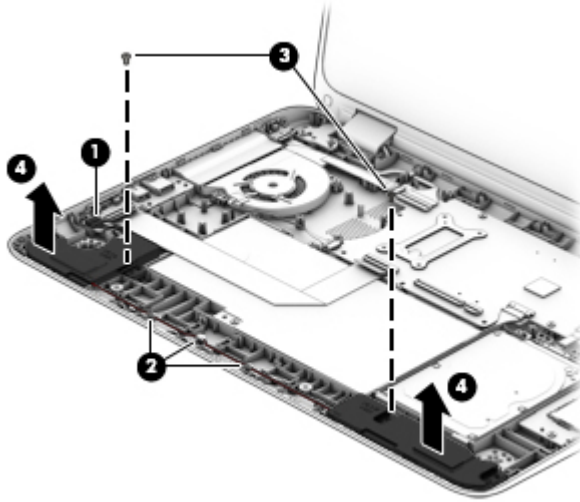

Reverse this procedure to install the speakers.

## USB/audio board

Description	Spare part number
USB/audio board (includes cable)	774600-001

Before removing the USB/audio board, follow these steps:

1. Shut down the computer. If you are unsure whether the computer is off or in Hibernation, turn the computer on, and then shut it down through the operating system.
2. Disconnect all external devices connected to the computer.
3. Disconnect the power from the computer by first unplugging the power cord from the AC outlet and then unplugging the AC adapter from the computer.
4. Remove the top cover (see [Top cover on page 30](#)).

To remove the USB/audio board:

1. Disconnect the USB/audio cable from the system board **(1)**.
2. Disconnect the speaker cable from the USB/audio board **(2)**.
3. Remove the Phillips PM2.5×4.0 screw **(3)**.
4. Lift the USB/audio board and cable from the computer **(4)**.

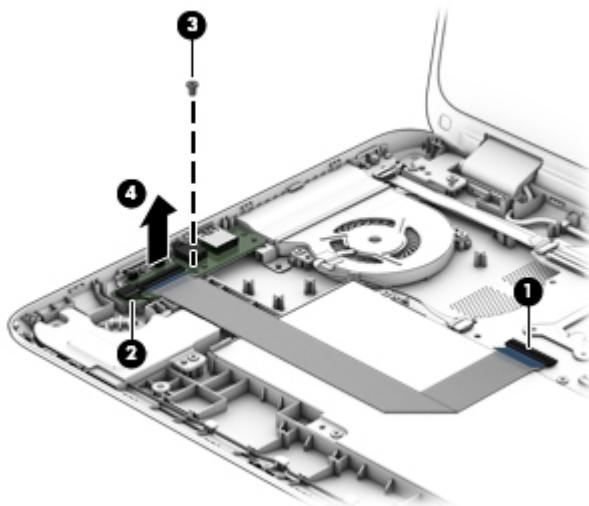

Reverse this procedure to install the USB/audio board.

## Fan

Description	Spare part number
Fan	778793-001

Before removing the fan, follow these steps:

1. Turn off the computer. If you are unsure whether the computer is off or in Hibernation, turn the computer on, and then shut it down through the operating system.
2. Disconnect the power from the computer by unplugging the power cord from the computer.
3. Disconnect all external devices from the computer.
4. Remove the top cover (see [Top cover on page 30](#)).
5. Disconnect the battery.

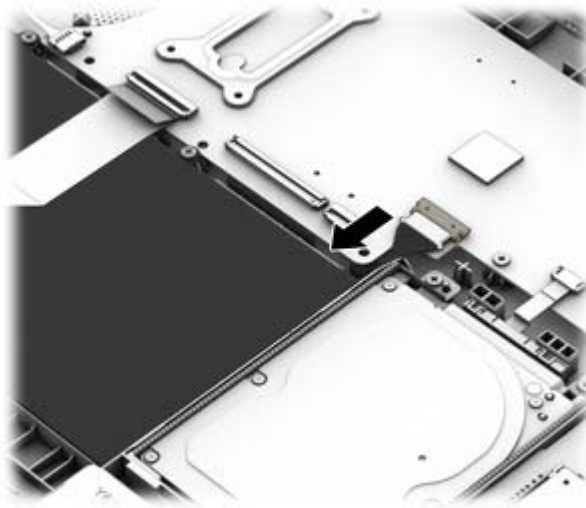

Remove the fan:



**NOTE:** You do not have to remove the heat sink to remove the fan.

1. Disconnect the fan cable **(1)** from the system board.
2. Remove the three Phillips PM2.5×4.0 screws **(2)** that secure the fan to the computer.

**3. Remove the fan (3).**

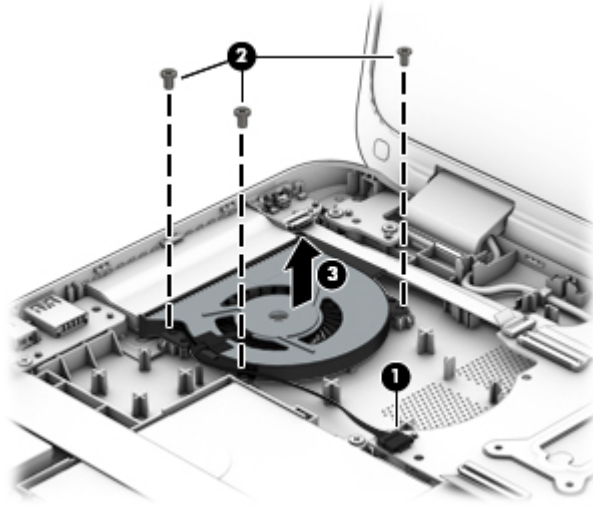

Reverse this procedure to install the fan.

## Power button board

Description	Spare part number
Power button board (includes cable)	774599-001

Before removing the power button board, follow these steps:

1. Turn off the computer. If you are unsure whether the computer is off or in Hibernation, turn the computer on, and then shut it down through the operating system.
2. Disconnect the power from the computer by unplugging the power cord from the computer.
3. Disconnect all external devices from the computer.
4. Remove the top cover (see [Top cover on page 30](#)).
5. Disconnect the battery.

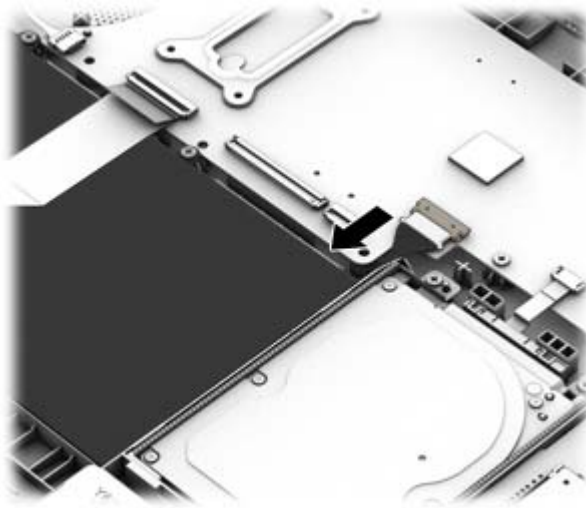

Remove the power button board:

1. Disconnect the power button board cable **(1)** from the system board.
2. Remove the Phillips PM2.5×4.0 screw **(2)** that secures the power button board to the computer.

3. Remove the power button board and cable (3).

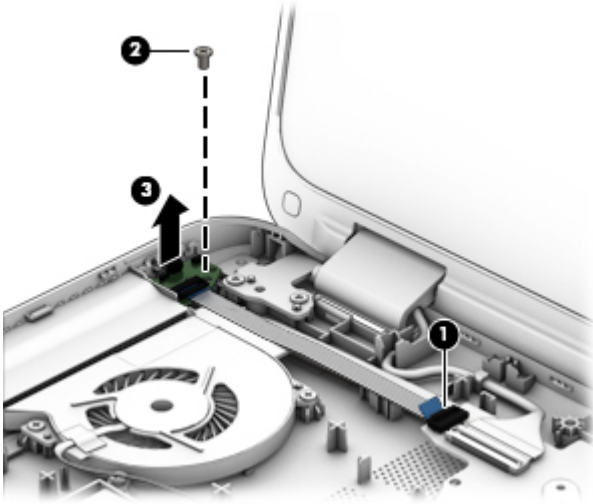

Reverse this procedure to install the power button board.



## System board



**NOTE:** The system board spare part kit includes replacement thermal material.

Description	Spare part number
Intel Core i7-5500U processor and a non-Windows 8 operating system	782305-001
Intel Core i7-5500U processor and the Windows 8.1 Standard operating system	782305-501
Intel Core i7-4510U processor and a non-Windows 8 operating system	780958-001
Intel Core i7-4510U processor and the Windows 8.1 Standard operating system	780958-501
Intel Core i5-5200U processor and a non-Windows 8 operating system	782306-001
Intel Core i5-5200U processor and the Windows 8.1 Standard operating system	782306-501
Intel Core i5-4210U processor and a non-Windows 8 operating system	774606-001
Intel Core i5-4210U processor and the Windows 8.1 Standard operating system	774606-501
Intel Core i3-5010U processor and a non-Windows 8 operating system	802987-001
Intel Core i3-5010U processor and the Windows 8.1 Standard operating system	802987-501
Intel Core i3-5005U processor and a non-Windows 8 operating system	782307-001
Intel Core i3-5005U processor and the Windows 8.1 Standard operating system	782307-501
Intel Core i3-4030U processor and a non-Windows 8 operating system	774607-001
Intel Core i3-4030U processor and the Windows 8.1 Standard operating system	774607-501

Before removing the system board, follow these steps:

1. Turn off the computer. If you are unsure whether the computer is off or in Hibernation, turn the computer on, and then shut it down through the operating system.
2. Disconnect the power from the computer by unplugging the power cord from the computer.
3. Disconnect all external devices from the computer.
4. Remove the top cover (see [Top cover on page 30](#)).

5. Disconnect the battery.

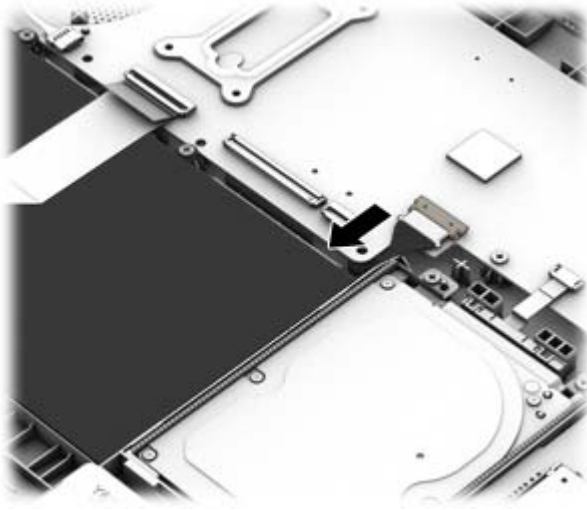

---

 **NOTE:** When replacing the system board, be sure that the following components are removed from the defective system board and installed on the replacement system board:

---

- WLAN module (see [WLAN module on page 40](#))
- Memory module (see [Memory module on page 52](#))
- Heat sink (see [Heat sink on page 54](#))

Remove the system board:

1. Disconnect the following cables from the system board:
  - (1): Power button board cable
  - (2): Left display cable
  - (3): Power connector cable
  - (4): Right display cable
  - (5): Fan cable
  - (6): USB/audio cable
  - (7): Hard drive cable

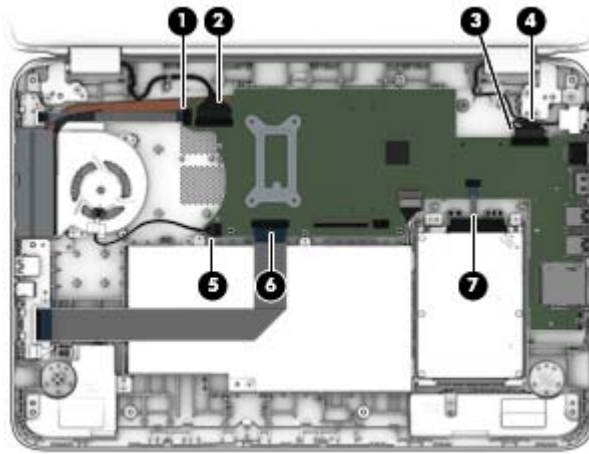

2. Remove the two nuts **(1)** that secure the system board to the computer.
3. Remove the five Phillips PM2.5×4.0 screws **(2)** that secure the system board to the computer.
4. Flex the side of the computer so you can lift the heat sink out **(3)**, and then lift the left side of the system board **(4)**, and then pull it away from the side connectors and remove it from the computer.

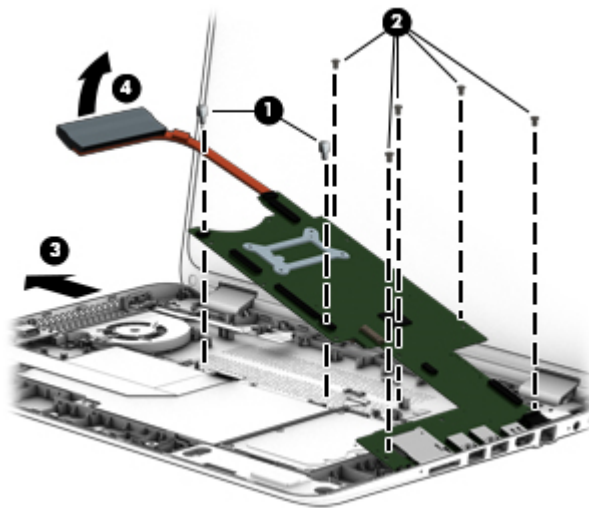

5. Reverse this procedure to install the system board.

## Memory module

Description	Spare part number
8-GB (PC3L, 12800, 1600-MHz)	693374-005
4-GB (PC3L, 12800, 1600-MHz)	691740-005
2-GB (PC3L, 12800, 1600-MHz)	691739-005

### Update BIOS before adding memory modules

Before adding new memory, make sure you update the computer to the latest BIOS.

 **CAUTION:** Failure to update the computer to the latest BIOS prior to installing new memory may result in various system problems.

To update BIOS:

1. Navigate to [www.hp.com](http://www.hp.com).
2. Click **Support & Drivers** > **click Drivers & Software**.
3. In the **Enter a product name/number box**, type the computer model information, and then click **Search**.
4. Click the link for the computer model.
5. Select the operating system, and then click **Next**.
6. Under **Step 2: Select a Download**, click the **BIOS** link.
7. Click the link for the most recent BIOS.
8. Click the **Download** button, and then follow the on-screen instructions.

Before removing a memory module, follow these steps:

1. Turn off the computer. If you are unsure whether the computer is off or in Hibernation, turn the computer on, and then shut it down through the operating system.
2. Disconnect the power from the computer by unplugging the power cord from the computer.
3. Disconnect all external devices from the computer.
4. Remove the top cover (see [Top cover on page 30](#)).

5. Disconnect the battery.

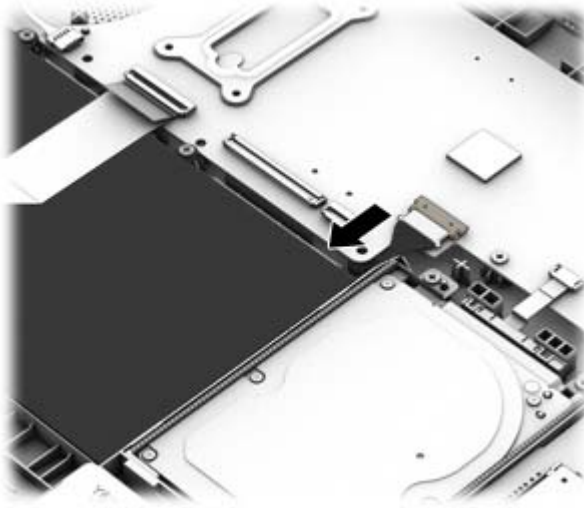

6. Remove the WLAN module (see [WLAN module on page 40](#)).
7. Remove the system board (see [System board on page 49](#)).

Remove the memory module:

1. Position the system board upside-down.
2. Spread the retaining tabs **(1)** on each side of the memory module slot to release the memory module. (The memory module tilts up.)
3. Remove the memory module **(2)** by pulling the module away from the slot at an angle.

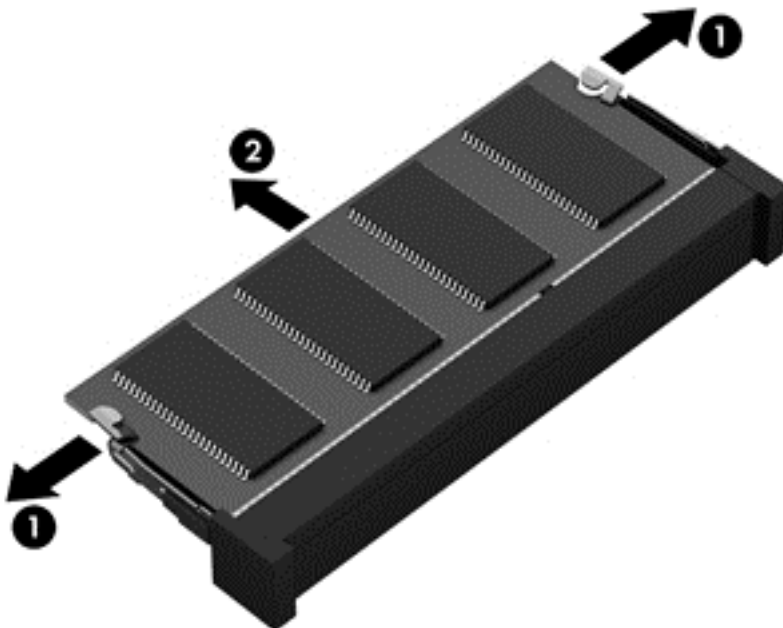

Reverse this procedure to install a memory module.

## Heat sink

Description	Spare part number
Heat sink (includes replacement thermal material)	774595-001

Before removing the heat sink, follow these steps:

1. Turn off the computer. If you are unsure whether the computer is off or in Hibernation, turn the computer on, and then shut it down through the operating system.
2. Disconnect the power from the computer by unplugging the power cord from the computer.
3. Disconnect all external devices from the computer.
4. Remove the top cover (see [Top cover on page 30](#)).
5. Disconnect the battery.

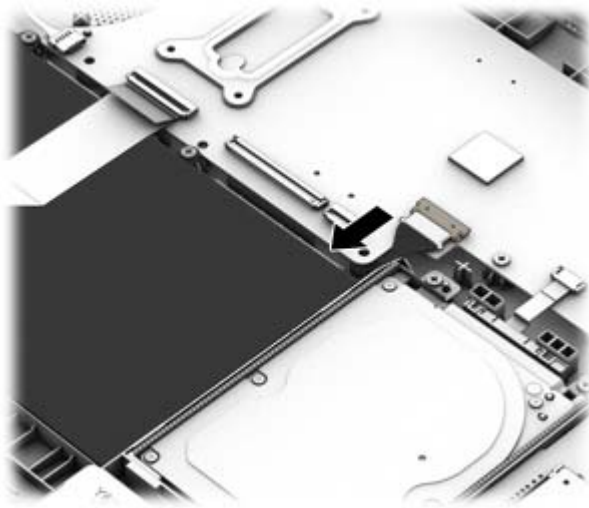

6. Remove the WLAN module (see [WLAN module on page 40](#)).
7. Remove the system board (see [System board on page 49](#)).

Remove the heat sink:





**NOTE:** You do not have to remove the fan to remove the heat sink. You must disengage the tape that secures the heat sink to the fan.

1. Position the system board upside-down.
2. Following the 1 through 4 sequence stamped into the heat sink, loosen the four captive Phillips screws **(1)** that secure the heat sink to the system board.

3. Remove the heat sink (2).

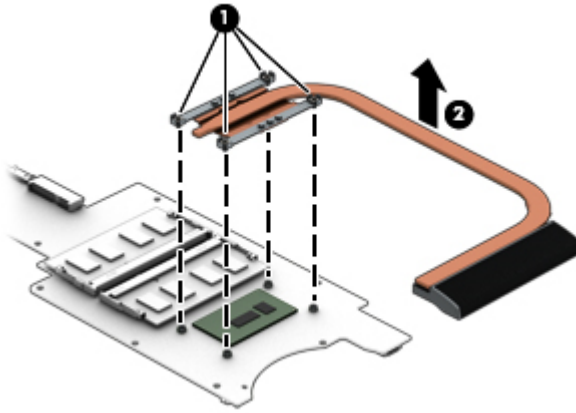
 **NOTE:** Due to the adhesive quality of the thermal material located between the heat sink and the system board components, it may be necessary to move the heat sink from side to side to detach it.



 **NOTE:** The thermal material must be thoroughly cleaned from the surfaces of the heat sink and the system board components each time the heat sink is removed. Thermal paste is used on the processor (1) and the heat sink section (2) that services it

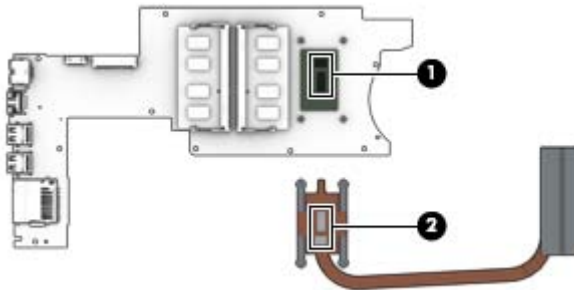

Reverse this procedure to install the heat sink.

## Display assembly

Before removing the display assembly, follow these steps:

1. Shut down the computer. If you are unsure whether the computer is off or in Hibernation, turn the computer on, and then shut it down through the operating system.
2. Disconnect all external devices connected to the computer.
3. Disconnect the power from the computer by first unplugging the power cord from the AC outlet and then unplugging the AC adapter from the computer.
4. Remove the top cover (see [Top cover on page 30](#)).
5. Disconnect the battery.

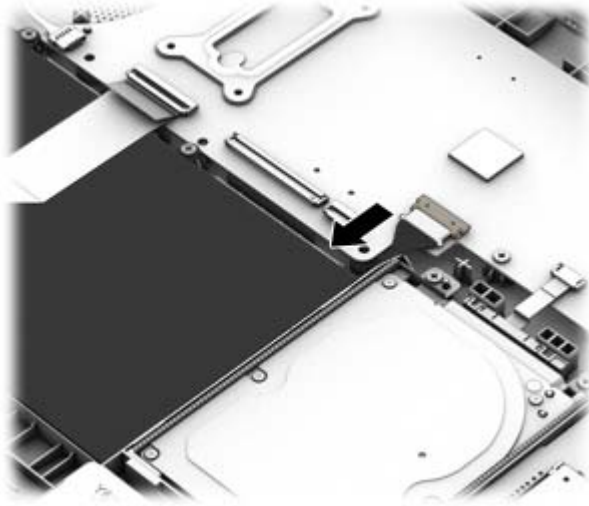

To remove the display assembly:

1. Disconnect the left display panel cable **(1)** from the system board.
2. Disconnect the antenna cables **(2)** from the WLAN module.
3. Disconnect the right display panel cable **(3)** from the system board.

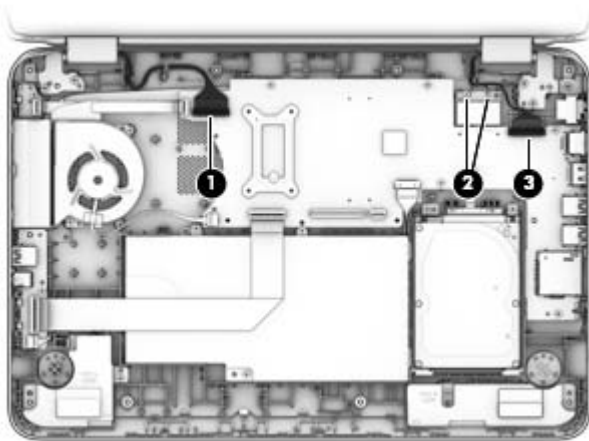

4. Remove two Phillips PM2.5×5.5 screws from each hinge **(1)** and the smaller Phillips PM2.5×3.6 screw from the right hinge **(2)** that secures the display assembly to the computer.



**⚠ CAUTION:** Support the display assembly when removing the screws. Failure to support the display assembly can result in damage to the display assembly and other computer components.

5. Remove the display assembly from the computer **(3)**.

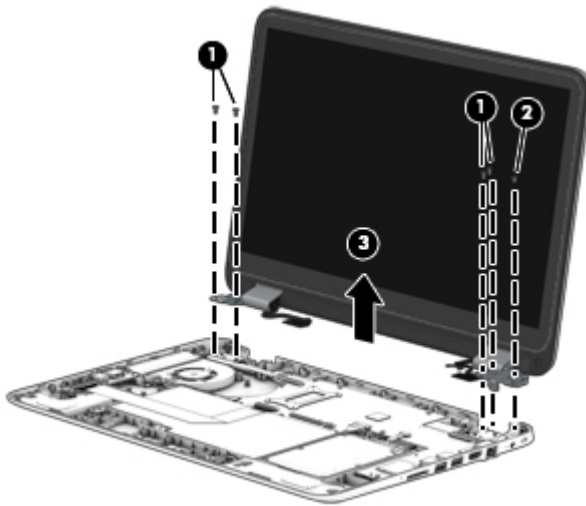

If it is necessary to replace any of the display assembly subcomponents:

1. To remove the display panel and bezel from the display enclosure:

**📝 NOTE:** The display enclosure is available using spare part number 774591-001.

- a. Remove the two screw covers **(1)**.
- b. Remove the two Phillips PM2.5×4.0 screws **(2)** that secure the enclosure to the display panel.
- c. Pry to separate the enclosure from the display **(3)**.

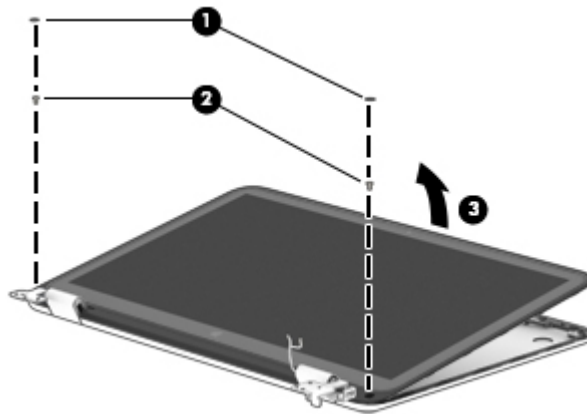

2. The webcam module is mounted on the inside of the bezel. To remove the webcam module:

**📝 NOTE:** The webcam is available using spare part number 768040-001.

- a. Position the display bezel/display panel assembly upside-down.
- b. Disconnect the cable **(1)** from the module.

- c. Use a thin tool to lift the webcam module to disengage the adhesive that secures it to the display **(2)**, and then remove the webcam module **(3)**.

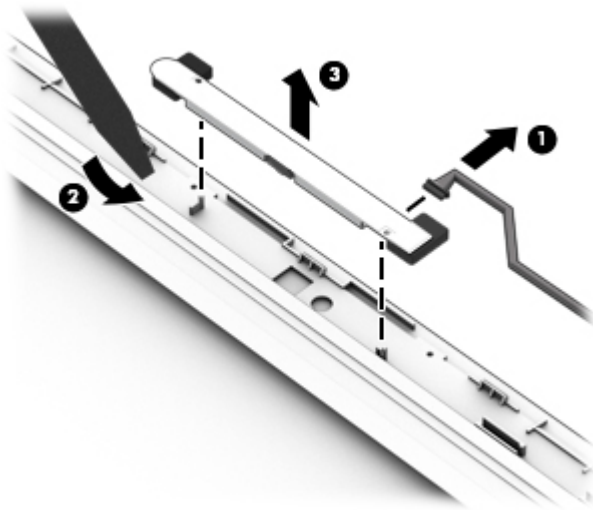

3. The touch screen display cable connects to the board at the bottom of the bezel. To disconnect the touch screen display cable from the display bezel, pull the cable upward to disconnect.

---

 **NOTE:** The touch screen display cable is available in the cable kit using spare part number 774593-001 for HD panels and 774594-001 for FHD panels.

---



4. The display/webcam cable connects to the bottom of the display panel. To remove the display/webcam cable:

---

 **NOTE:** The display/webcam cable is available in the cable kit using spare part number 774593-001 for HD models and 774594-001 for FHD models.

---

- a. Position the display bezel/display panel assembly upside-down.
- b. Disconnect the display cable from the connector at the bottom of the display panel **(1)**.
- c. Disconnect the webcam cable from the webcam **(2)**.
- d. Remove the cable from the routing path and clips along the right side of the display bezel **(3)**.

- e. Remove the display/webcam cable (4).

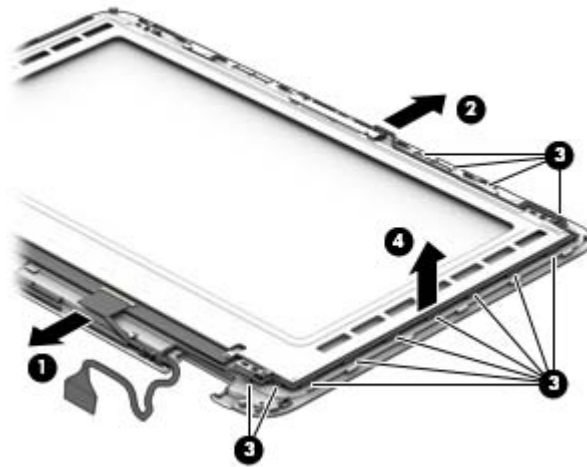

5. To remove the display panel from the bezel:

 **NOTE:** The display panel and bezel are available using spare part number 774602-001 for HD panels and 774603-001 for FHD panels.

- Position the display bezel/display panel assembly upside-down.
- If necessary, disconnect the display/webcam cable from the connector at the bottom of the display panel (1).
- Remove the four Phillips PM2.0×3.0 screws (2) that secure the display panel to the display enclosure.
- Remove the display panel from the bezel (3).

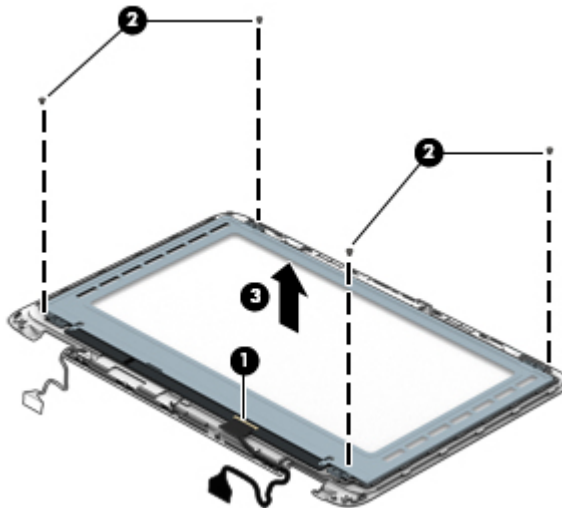

6. The display hinges are located in the display enclosure. To remove the display hinges:

 **NOTE:** The display hinges are available using spare part number 774596-001.

- a. Position the display enclosure so you can access the internal parts.
- b. Remove the four Phillips PM2.5×4.0 screws from the bottom of the hinges **(1)** and the two Phillips PM2.0×3.0 screws **(2)** from the top of the hinges that secure the hinges to the display enclosure.
- c. Remove the hinges from the display **(3)**.

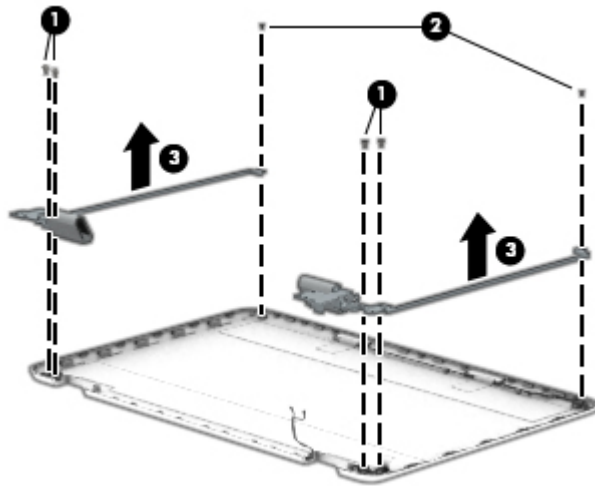

7. The hinge covers are installed on the display hinges. To remove the display hinge covers:

 **NOTE:** The display hinge covers are available using spare part number 774597-001.

- a. From the inside of the hinge covers, remove the two Phillips PM2.0×3.0 screws (one per hinge) **(1)** that secure the hinge covers to the hinges.
- b. Pull the hinge covers off the hinges **(2)**.

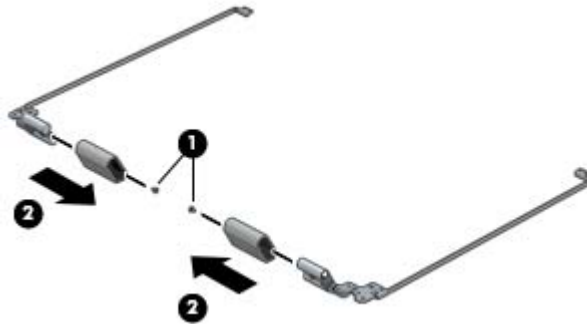

8. The antenna cables are installed in the display enclosure. To remove the antenna cables:

 **NOTE:** The antenna cables are available using spare part number 774590-001.

- a. Lift the tape that secures the antenna cables to the bottom of the display enclosure **(1)**.
- b. Remove the cables from the clips built into the enclosure **(2)**.

- c. Lift the tape that secures the transceivers at the top of the display (3), and then remove the antenna cables from the display enclosure (4).

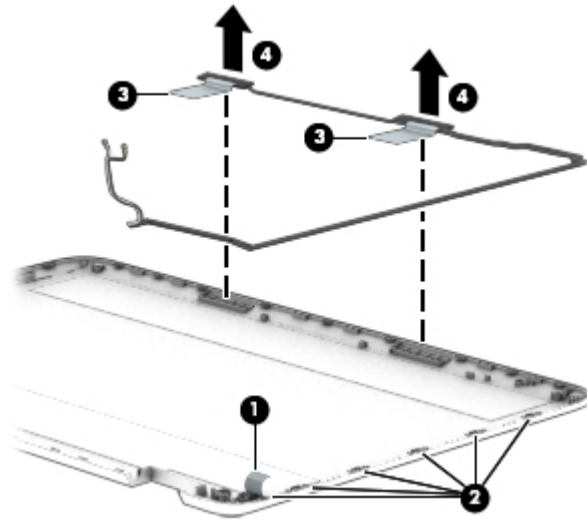

Reverse this procedure to reassemble and install the display assembly.

## Power connector cable

Description	Spare part number
Power connector cable	768012-001

Before removing the power connector cable, follow these steps:

1. Turn off the computer. If you are unsure whether the computer is off or in Hibernation, turn the computer on, and then shut it down through the operating system.
2. Disconnect the power from the computer by unplugging the power cord from the computer.
3. Disconnect all external devices from the computer.
4. Remove the top cover (see [Top cover on page 30](#)).
5. Disconnect the battery.

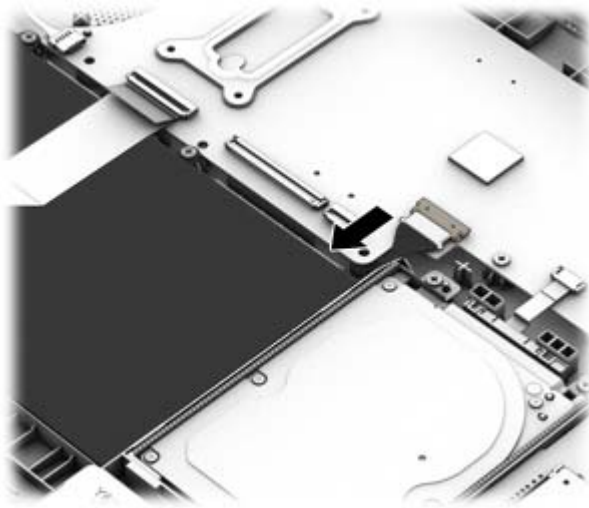

6. Remove the display (see [Display assembly on page 56](#)).

Remove the power connector cable:

1. Disconnect the power connector cable **(1)** from the system board.

2. Remove the power connector **(2)** from the computer.



Reverse this procedure to install the power connector cable.

---

## 6 Using Setup Utility (BIOS) and HP PC Hardware Diagnostics (UEFI)

Setup Utility, or Basic Input/Output System (BIOS), controls communication between all the input and output devices on the system (such as disk drives, display, keyboard, mouse, and printer). Setup Utility (BIOS) includes settings for the types of devices installed, the startup sequence of the computer, and the amount of system and extended memory.

### Starting Setup Utility (BIOS)

To start Setup Utility (BIOS), turn on or restart the computer, quickly press **esc**, and then press **f10**.



**NOTE:** Use extreme care when making changes in Setup Utility (BIOS). Errors can prevent the computer from operating properly.

---

### Updating the BIOS

Updated versions of the BIOS may be available on the HP website.

Most BIOS updates on the HP website are packaged in compressed files called *SoftPaqs*.

Some download packages contain a file named *Readme.txt*, which contains information regarding installing and troubleshooting the file.

### Determining the BIOS version

To determine whether available BIOS updates contain later BIOS versions than those currently installed on the computer, you need to know the version of the system BIOS currently installed.

BIOS version information (also known as *ROM date* and *System BIOS*) can be revealed by pressing **fn+esc** (if you are already in Windows) or by using Setup Utility (BIOS).

1. Start Setup Utility (BIOS) (see [Starting Setup Utility \(BIOS\) on page 64](#)).
2. Use the arrow keys to select **Main**.
3. To exit Setup Utility (BIOS) without saving your changes, use the arrow keys to select **Exit**, select **Exit Discarding Changes**, and then press **enter**.
4. Select **Yes**.



## Downloading a BIOS update

 **CAUTION:** To reduce the risk of damage to the computer or an unsuccessful installation, download and install a BIOS update only when the computer is connected to reliable external power using the AC adapter. Do not download or install a BIOS update while the computer is running on battery power, docked in an optional docking device, or connected to an optional power source. During the download and installation, follow these instructions:

Do not disconnect power from the computer by unplugging the power cord from the AC outlet.

Do not shut down the computer or initiate Sleep.

Do not insert, remove, connect, or disconnect any device, cable, or cord.

1. From the Start screen, type `hp support assistant`, and then select the **HP Support Assistant** app.
2. Click **Updates and tune-ups**, and then click **Check for HP updates now**.
3. Follow the on-screen instructions.
4. At the download area, follow these steps:
  - a. Identify the most recent BIOS update and compare it to the BIOS version currently installed on your computer. If the update is more recent than your BIOS, make a note of the date, name, or other identifier. You may need this information to locate the update later, after it has been downloaded to your hard drive.
  - b. Follow the on-screen instructions to download your selection to the hard drive.

If the update is more recent than your BIOS, make a note of the path to the location on your hard drive where the BIOS update is downloaded. You will need to access this path when you are ready to install the update.

 **NOTE:** If you connect your computer to a network, consult the network administrator before installing any software updates, especially system BIOS updates.

BIOS installation procedures vary. Follow any instructions that are revealed on the screen after the download is complete. If no instructions are revealed, follow these steps:

1. From the Start screen, type `file`, and then select **File Explorer**.
2. Click your hard drive designation. The hard drive designation is typically Local Disk (C:).
3. Using the hard drive path you recorded earlier, open the folder on your hard drive that contains the update.
4. Double-click the file that has an `.exe` extension (for example, `filename.exe`).

The BIOS installation begins.
5. Complete the installation by following the on-screen instructions.

 **NOTE:** After a message on the screen reports a successful installation, you can delete the downloaded file from your hard drive.

## Using HP PC Hardware Diagnostics (UEFI)

HP PC Hardware Diagnostics is a Unified Extensible Firmware Interface (UEFI) that allows you to run diagnostic tests to determine whether the computer hardware is functioning properly. The tool runs outside

the operating system so that it can isolate hardware failures from issues that are caused by the operating system or other software components.

To start HP PC Hardware Diagnostics UEFI:

1. Turn on or restart the computer, quickly press **esc**, and then press **f2**.

The BIOS searches three places for the diagnostic tools, in the following order:

- a. Connected USB drive



**NOTE:** To download the HP PC Hardware Diagnostics (UEFI) tool to a USB drive, see [Downloading HP PC Hardware Diagnostics \(UEFI\) to a USB device on page 66](#).

- b. Hard drive
- c. BIOS

2. When the diagnostic tool opens, use the keyboard arrow keys to select the type of diagnostic test you want to run, and then follow the on-screen instructions.



**NOTE:** If you need to stop a diagnostic test, press **esc**.

## Downloading HP PC Hardware Diagnostics (UEFI) to a USB device



**NOTE:** Instructions for downloading HP PC Hardware Diagnostics (UEFI) are provided in English only.

There are two options to download HP PC Hardware Diagnostics to USB device.

**Option 1: HP PC Diagnostics homepage**—Provides access to the latest UEFI version

1. Go to <http://www.hp.com/go/techcenter/pcdiags>.
2. Click the **UEFI Download** link, and then select **Run**.

**Option 2: Support and Drivers pages**—Provides downloads for a specific product for earlier and later versions.

1. Go to <http://www.hp.com>.
2. Point to Support, located at the top of the page, and then click **Download Drivers**.
3. In the text box, enter the product name, and then click **Go**.

– or –

Click **Find Now** to let HP automatically detect your product.

4. Select your computer model, and then select your operating system.
5. In the **Diagnostic** section, click **HP UEFI Support Environment**.
6. Click **Download**, and then select **Run**.

# 7 Specifications

## Computer specifications

	Metric	U.S.
<b>Dimensions</b>		
Width	<b>383.7 mm</b>	15.11 in
Depth	<b>258.5 mm</b>	10.18 in
Height – Front	<b>7.55 mm</b>	0.30 in
Height – Rear	<b>23.60 mm</b>	0.93 in
Weight – with HDD	<b>2.4 kg</b>	5.29 lbs
Weight – with SSD	<b>2.3 kg</b>	5.07 lbs
<b>Input power</b>		
Operating voltage and current	19.5 V dc @ 3.33 A – 65 W	
	19.5 V dc @ 2.31 A – 45 W	
<b>Temperature</b>		
Operating	<b>5°C to 35°C</b>	41°F to 95°F
Nonoperating	<b>-20°C to 60°C</b>	-4°F to 140°F
<b>Relative humidity</b> (noncondensing)		
Operating	10% to 90%	
Nonoperating	5% to 95%	
<b>Maximum altitude</b> (unpressurized)		
Operating	<b>-15 m to 3,048 m</b>	-50 ft to 10,000 ft
Nonoperating	<b>-15 m to 12,192 m</b>	-50 ft to 40,000 ft
<b>NOTE:</b> Applicable product safety standards specify thermal limits for plastic surfaces. The device operates well within this range of temperatures.		

## Hard drive specifications

	500-GB*	500-GB* hybrid
<b>Dimensions</b>		
Height	7.0 mm	7.0 mm
Width	69.9 mm	70 mm
Weight	110 g	95 g
<b>Interface type</b>	SATA	SATA
<b>Transfer rate</b> (synchronous, maximum)	1.1 GB/sec	100 MB/sec
<b>Security</b>	ATA security	ATA security
<b>Seek times</b> (typical read, including setting)		
Single track	1.5 ms	2 ms
Average (read/write)	11/13 ms	12 ms
Maximum	22 ms	22 ms
<b>Logical blocks</b>	976,773,168	976,773,168
<b>Disk rotational speed</b>	5400 rpm	5400 rpm
<b>Operating temperature</b>	0°C to 60°C (32°F to 140°F)	0°C to 60°C (32°F to 140°F)
*1 GB = 1 billion bytes when referring to hard drive storage capacity. Actual accessible capacity is less.		
<b>NOTE:</b> Certain restrictions and exclusions apply. Contact technical support for details.		

## Solid-state drive specifications

	256-GB* MLC	256-GB* TLC
<b>Height</b>	1.5 mm	1.5 mm
<b>Weight</b>	< 10 g	< 50 g
<b>Form factor</b>	M.2 2280-S3-B-M	M.2 2280-S3-B-M
<b>Transfer rate</b>	up to 520 MB/sec	up to 500 MB/sec
<b>Interface type</b>	SATA-3	SATA-3
Ready time, maximum (to not busy)	1.0 ms	< 1.0 ms
Access times, logical	0.1 ms	0.1 ms
<b>Total logical sectors</b>	500,118,192	500,118,192
<b>Operating temperature</b>	0°C to 70°C (32°F to 158°F)	0°C to 70°C (32°F to 158°F)
*1 GB = 1 billion bytes when referring to hard drive storage capacity. Actual accessible capacity is less. Actual drive specifications may differ slightly.		
<b>NOTE:</b> Certain restrictions and exclusions apply. Contact technical support for details.		

---

# 8 Backing up, restoring, and recovering

This chapter provides information about the following processes:

- Creating recovery media and backups
- Restoring and recovering your system

## Creating recovery media and backups

1. After you successfully set up the computer, create HP Recovery media. This step creates a backup of the HP Recovery partition on the computer. The backup can be used to reinstall the original operating system in cases where the hard drive is corrupted or has been replaced.

HP Recovery media you create will provide the following recovery options:

- **System Recovery**—Reinstalls the original operating system and the programs that were installed at the factory.
- **Minimized Image Recovery**—Reinstalls the operating system and all hardware-related drivers and software, but not other software applications.
- **Factory Reset**—Restores the computer to its original factory state by deleting all information from the hard drive and re-creating the partitions. Then it reinstalls the operating system and the software that was installed at the factory.

See [Creating HP Recovery media on page 69](#).

2. Use the Windows tools to create system restore points and create backups of personal information. For more information and steps, see Help and Support. From the Start screen, type `help`, and then select **Help and Support**.

## Creating HP Recovery media

HP Recovery Manager is a software program that offers a way to create recovery media after you successfully set up the computer. HP Recovery media can be used to perform system recovery if the hard drive becomes corrupted. System recovery reinstalls the original operating system and the software programs installed at the factory, and then configures the settings for the programs. HP Recovery media can also be used to customize the system or restore the factory image if you replace the hard drive.

- Only one set of HP Recovery media can be created. Handle these recovery tools carefully, and keep them in a safe place.
- HP Recovery Manager examines the computer and determines the required storage capacity for the blank USB flash drive or the number of blank DVD discs that will be required.
- To create recovery discs, your computer must have an optical drive with DVD writer capability, and you must use only high-quality blank DVD-R, DVD+R, DVD-R DL, or DVD+R DL discs. Do not use rewritable discs such as CD±RW, DVD±RW, double-layer DVD±RW, or BD-RE (rewritable Blu-ray) discs; they are not compatible with HP Recovery Manager software. Or instead you can use a high-quality blank USB flash drive.
- If your computer does not include an integrated optical drive with DVD writer capability, but you would like to create DVD recovery media, you can use an external optical drive (purchased separately) to create recovery discs, or you can obtain recovery discs for your computer from support. See the

*Worldwide Telephone Numbers* booklet included with the computer. You can also find contact information from the HP website. Go to <http://www.hp.com/support>, select your country or region, and follow the on-screen instructions. If you use an external optical drive, it must be connected directly to a USB port on the computer; the drive cannot be connected to a USB port on an external device, such as a USB hub.

- Be sure that the computer is connected to AC power before you begin creating the recovery media.
- The creation process can take up to an hour or more. Do not interrupt the creation process.
- If necessary, you can exit the program before you have finished creating all of the recovery DVDs. HP Recovery Manager will finish burning the current DVD. The next time you start HP Recovery Manager, you will be prompted to continue, and the remaining discs will be burned.

To create HP Recovery media:



**IMPORTANT:** For tablets, connect to the keyboard dock before beginning these steps (select models only).

1. From the Start screen, type `recovery`, and then select **HP Recovery Manager**.
2. Select **Recovery Media Creation**, and then follow the on-screen instructions.

If you ever need to recover the system, see [Recovering using HP Recovery Manager on page 71](#).

## Restore and recovery

There are several options for recovering your system. Choose the method that best matches your situation and level of expertise:

- Windows offers several options for restoring from backup, refreshing the computer, and resetting the computer to its original state. For more information and steps, see Help and Support. From the Start screen, type `help`, and then select **Help and Support**.
- If you need to correct a problem with a preinstalled application or driver, use the Drivers and Applications Reinstall option of HP Recovery Manager to reinstall the individual application or driver.

From the Start screen, type `recovery`, select **HP Recovery Manager**, select **Drivers and Applications Reinstall**, and then follow the on-screen instructions.

- If you want to reset your computer using a minimized image, you can choose the HP Minimized Image Recovery option from the HP Recovery partition (select models only) or HP Recovery media. Minimized Image Recovery installs only drivers and hardware-enabling applications. Other applications included in the image continue to be available for installation through the Drivers and Applications Reinstall option in HP Recovery Manager.

For more information, see [Recovering using HP Recovery Manager on page 71](#).

- If you want to recover the computer's original factory partitioning and content, you can choose the System Recovery option from the HP Recovery partition (select models only) or use the HP Recovery media that you have created. For more information, see [Recovering using HP Recovery Manager on page 71](#). If you have not already created recovery media, see [Creating HP Recovery media on page 69](#).
- If you have replaced the hard drive, you can use the Factory Reset option of HP Recovery media to restore the factory image to the replacement drive. For more information, see [Recovering using HP Recovery Manager on page 71](#).
- If you wish to remove the recovery partition to reclaim hard drive space, HP Recovery Manager offers the Remove Recovery Partition option.

For more information, see [Removing the HP Recovery partition \(select models only\) on page 72](#).

## Recovering using HP Recovery Manager

HP Recovery Manager software allows you to recover the computer to its original factory state by using the HP Recovery media that you created or by using the HP Recovery partition (select models only). If you have not already created recovery media, see [Creating HP Recovery media on page 69](#).

Using HP Recovery media, you can choose from one of the following recovery options:

- System Recovery—Reinstalls the original operating system, and then configures the settings for the programs that were installed at the factory.
- Minimized Image Recovery (select models only)—Reinstalls the operating system and all hardware-related drivers and software, but not other software applications.
- Factory Reset—Restores the computer to its original factory state by deleting all information from the hard drive and re-creating the partitions. Then it reinstalls the operating system and the software that was installed at the factory.

The HP Recovery partition (select models only) allows System Recovery and Minimized Image Recovery.

### What you need to know

- HP Recovery Manager recovers only software that was installed at the factory. For software not provided with this computer, you must either download the software from the manufacturer's website or reinstall the software from the media provided by the manufacturer.
- Recovery through HP Recovery Manager should be used as a final attempt to correct computer issues.
- HP Recovery media must be used if the computer hard drive fails. If you have not already created recovery media, see [Creating HP Recovery media on page 69](#).
- To use the Factory Reset option, you must use HP Recovery media. If you have not already created recovery media, see [Creating HP Recovery media on page 69](#).
- If the HP Recovery media does not work, you can obtain recovery media for your system from support. See the *Worldwide Telephone Numbers* booklet included with the computer. You can also find contact information from the HP website. Go to <http://www.hp.com/support>, select your country or region, and follow the on-screen instructions.



---

**IMPORTANT:** HP Recovery Manager does not automatically provide backups of your personal data. Before beginning recovery, back up any personal data you wish to retain.

---

### Using the HP Recovery partition (select models only)

The HP Recovery partition (select models only) allows you to perform a system recovery or minimized image recovery without the need for recovery discs or a recovery USB flash drive. This type of recovery can only be used if the hard drive is still working.

To start HP Recovery Manager from the HP Recovery partition:



---

**IMPORTANT:** For tablets, connect to the keyboard dock before beginning these steps (select models only).

---

1. Press **f11** while the computer boots.

– or –

Press and hold **f11** as you press the power button.

2. Select **Troubleshoot** from the boot options menu.
3. Select **Recovery Manager**, and then follow the on-screen instructions.

## Using HP Recovery media to recover

You can use HP Recovery media to recover the original system. This method can be used if your system does not have an HP Recovery partition or if the hard drive is not working properly.

1. If possible, back up all personal files.
2. Insert the HP Recovery media that you created, and then restart the computer.



---

**NOTE:** If the computer does not automatically restart in HP Recovery Manager, change the computer boot order. See [Changing the computer boot order on page 72](#).

---

3. Follow the on-screen instructions.

## Changing the computer boot order

If computer does not restart in HP Recovery Manager, you can change the computer boot order, which is the order of devices listed in BIOS where the computer looks for startup information. You can change the selection for an optical drive or a USB flash drive.

To change the boot order:

1. Insert the HP Recovery media you created.
2. Restart the computer, quickly press **esc**, and then press **f9** for boot options.
3. Select the optical drive or USB flash drive you want to boot from.
4. Follow the on-screen instructions.

## Removing the HP Recovery partition (select models only)

HP Recovery Manager software allows you to remove the HP Recovery partition to free up hard drive space.



---

**IMPORTANT:** After you remove the HP Recovery partition, you can no longer use the Windows Refresh option or the Windows option to remove everything and reinstall Windows. In addition, you will not be able to perform System Recovery or Minimized Image Recovery from the HP Recovery partition. So before you remove the Recovery partition, create HP Recovery media; see [Creating HP Recovery media on page 69](#).

---

Follow these steps to remove the HP Recovery partition:

1. From the Start screen, type `recovery`, and then select **HP Recovery Manager**.
2. Select **Remove Recovery Partition**, and then follow the on-screen instructions.



## 9 Power cord set requirements

The wide-range input feature of the computer permits it to operate from any line voltage from 100 to 120 volts AC, or from 220 to 240 volts AC.

The 3-conductor power cord set included with the computer meets the requirements for use in the country or region where the equipment is purchased.

Power cord sets for use in other countries and regions must meet the requirements of the country or region where the computer is used.

### Requirements for all countries

The following requirements are applicable to all countries and regions:

- The length of the power cord set must be at least 1.0 m (3.3 ft) and no more than 2.0 m (6.5 ft).
- All power cord sets must be approved by an acceptable accredited agency responsible for evaluation in the country or region where the power cord set will be used.
- The power cord sets must have a minimum current capacity of 10 amps and a nominal voltage rating of 125 or 250 V AC, as required by the power system of each country or region.
- The appliance coupler must meet the mechanical configuration of an EN 60 320/IEC 320 Standard Sheet C13 connector for mating with the appliance inlet on the back of the computer. Requirements for all countries 113

### Requirements for specific countries and regions

Country/region	Accredited agency	Applicable note number
Australia	EANSW	1
Austria	OVE	1
Belgium	CEBC	1
Canada	CSA	2
Denmark	DEMKO	1
Finland	FIMKO	1
France	UTE	1
Germany	VDE	1
Italy	IMQ	1
Japan	METI	3
The Netherlands	KEMA	1
Norway	NEMKO	1
The People's Republic of China	COC	5

Country/region	Accredited agency	Applicable note number
South Korea	EK	4
Sweden	CEMKO	1
Switzerland	SEV	1
Taiwan	BSMI	4
The United Kingdom	BSI	1
The United States	UL	2

1. The flexible cord must be Type H05VV-F, 3-conductor, 1.0-mm<sup>2</sup> conductor size. Power cord set fittings (appliance coupler and wall plug) must bear the certification mark of the agency responsible for evaluation in the country or region where it will be used.
2. The flexible cord must be Type SPT-3 or equivalent, No. 18 AWG, 3-conductor. The wall plug must be a two-pole grounding type with a NEMA 5-15P (15 A, 125 V) or NEMA 6-15P (15 A, 250 V) configuration.
3. The appliance coupler, flexible cord, and wall plug must bear a “T” mark and registration number in accordance with the Japanese Dentori Law. The flexible cord must be Type VCT or VCTF, 3-conductor, 1.00-mm<sup>2</sup> conductor size. The wall plug must be a two-pole grounding type with a Japanese Industrial Standard C8303 (7 A, 125 V) configuration.
4. The flexible cord must be Type RVV, 3-conductor, 0.75-mm<sup>2</sup> conductor size. Power cord set fittings (appliance coupler and wall plug) must bear the certification mark of the agency responsible for evaluation in the country or region where it will be used.
5. The flexible cord must be Type VCTF, 3-conductor, 0.75-mm<sup>2</sup> conductor size. Power cord set fittings (appliance coupler and wall plug) must bear the certification mark of the agency responsible for evaluation in the country or region where it will be used.

---

## 10 Recycling

When a non-rechargeable or rechargeable battery has reached the end of its useful life, do not dispose of the battery in general household waste. Follow the local laws and regulations in your area for battery disposal.

HP encourages customers to recycle used electronic hardware, HP original print cartridges, and rechargeable batteries. For more information about recycling programs, see the HP Web site at <http://www.hp.com/recycle>.

# Index

- A**
  - AC adapter 4
  - AC adapter, spare part numbers 21
  - action keys
    - identifying 11
  - antenna
    - spare part number 19, 22
  - antenna, spare part number 19, 22
  - audio, product description 2
  - audio-out (headphone)/audio-in (microphone) jack 5
- B**
  - backups 69
  - base enclosure
    - spare part number 17, 22, 24
  - battery
    - removal 33
    - spare part number 16, 22, 33
  - bezel
    - spare part number 19
  - BIOS
    - determining version 64
    - downloading an update 65
    - updating 64
  - Bluetooth label 13
  - boot order
    - changing HP Recovery Manager 72
  - bottom 13
  - buttons
    - left TouchPad 8
    - power 5, 10
    - right TouchPad 8
    - volume 5
- C**
  - cables, service considerations 25
  - caps lock light, identifying 9
  - chipset, product description 1
  - components
    - bottom 12
    - display 6
    - left side 5
    - right side 4
    - top 8
  - computer
    - major components 15
    - specifications 67
  - connector, power 4
  - connectors, service considerations 25
  - control zone
    - left TouchPad 8
    - right TouchPad 8
- D**
  - deleted files
    - restoring 70
  - display assembly
    - removing 56
    - spare part number 15
    - subcomponents 19
  - display assembly subcomponents
    - removing 56
  - display bezel
    - removing 57
  - display cable
    - removing 58, 59, 60
  - display cable, spare part number 19, 22
  - display enclosure, spare part number 19, 22
  - display hinge
    - spare part number 19
  - display hinge cover kit, spare part number 22
  - display hinge covers
    - removing 59, 60
  - display hinge covers, spare part number 19
  - display hinges, spare part number 19, 22
  - display panel (raw)
    - spare part number 19, 22
  - display panel (raw), spare part number 19, 22
  - display panel, product description 1
  - drives, preventing damage 26
  - DVD±RW Double-Layer with SuperMulti Drive
    - precautions 26
    - spare part number 20, 21
- E**
  - electrostatic discharge 26
  - equipment guidelines 28
  - esc key, identifying 11
  - Ethernet, product description 2
  - external media cards, product description 2
- F**
  - fan
    - removal 45
    - spare part number 16, 23, 45
  - fn key, identifying 11
- G**
  - graphics, product description 1
  - grounding guidelines 26
  - guidelines
    - equipment 28
    - grounding 26
    - packaging 27
    - transporting 27
    - workstation 27
- H**
  - hard drive
    - precautions 26
    - product description 1
    - removal 36
    - spare part numbers 16, 20, 21, 22, 23, 36
    - specifications 68
  - hard drive bracket
    - removal 37, 39
  - hard drive bracket, illustrated 20
  - hard drive connector cable
    - removal 37, 39
  - hard drive connector cable, illustrated 20

- Hard Drive Hardware Kit
  - contents 20
  - spare part number 16, 22, 36
- Hard Drive Hardware Kit, spare part number 20
- hard drive light 4
- HDMI port
  - identifying 4
- HDMI to VGA adapter, spare part number 21
- heat sink
  - removal 54
  - spare part number 17, 22, 54
- hinge covers
  - removing 59, 60
- HP PC Hardware Diagnostics (UEFI)
  - downloading 66
  - using 66
- HP Recovery Manager
  - correcting boot problems 72
  - starting 71
- HP Recovery media
  - creating 69
  - recovery 72
- HP Recovery partition
  - recovery 71
  - removing 72

**I**

- integrated numeric keypad, identifying 11
- internal expansion, product description 2
- internal microphones, identifying 6

**J**

- jacks
  - audio-out (headphone)/audio-in (microphone) 5
  - network 4
  - RJ-45 (network) 4

**K**

- keys
  - action 11
  - esc 11
  - fn 11
  - Windows 11

**L**

- labels
  - Bluetooth 13
  - Microsoft Certificate of Authenticity 13
  - regulatory 13
  - serial number 13
  - wireless certification 13
  - WLAN 13
- lights
  - AC adapter 4
  - caps lock 9
  - hard drive 4
  - mute 9
  - power 9
  - RJ-45 (network) status 4

**M**

- mass storage device
  - illustrated 20
  - precautions 26
  - spare part numbers 20
- memory card reader, identifying 4
- memory card, identifying 4
- memory module
  - product description 1
  - removal 52
  - spare part numbers 17, 21, 52
- microphone
  - product description 2
- minimized image
  - creating 71
- minimized image recovery 71
- model name 1
- mute light, identifying 9

**N**

- network jack, identifying 4

**O**

- operating system, product description 3
- optical drive
  - precautions 26
  - product description 2
  - spare part number 20, 21
- original system recovery 71

**P**

- packaging guidelines 27
- PCID label 14

- plastic parts, service considerations 25
- ports
  - HDMI 4
  - product description 2
  - USB 2.0 5
  - USB 3.0 4
- power button board
  - removal 47
  - spare part number 16, 22, 47
- power button, identifying 5, 10
- power connector cable
  - removal 62
  - spare part number 16, 22, 62
- power connector, identifying 4
- power cord
  - set requirements 73
  - spare part numbers 21, 22
- power lights, identifying 9
- power requirements, product description 2
- processor, product description 1
- product description
  - audio 2
  - chipset 1
  - display panel 1
  - Ethernet 2
  - external media cards 2
  - graphics 1
  - hard drive 1
  - internal expansion 2
  - memory module 1
  - microphone 2
  - operating system 3
  - optical drive 2
  - ports 2
  - power requirements 2
  - processors 1
  - product name 1
  - security 3
  - serviceability 3
  - video 2
  - wireless 2
- product name 1
- product name and number, computer 13

**R**

- recovery
  - discs 69, 72

- HP Recovery Manager 71
  - media 72
  - options 70
  - starting 71
  - supported discs 69
  - system 71
  - USB flash drive 72
  - using HP Recovery media 70
- recovery media
  - creating 69
  - creating using HP Recovery Manager 70
- recovery partition
  - removing 72
- regulatory information
  - regulatory label 13
  - wireless certification labels 13
- removal/replacement
  - procedures 29
- restore
  - Windows File History 70
- RJ-45 (network) jack, identifying 4
- RJ-45 (network) status lights, identifying 4
- Rubber Feet Kit, spare part number 21, 22

**S**

- Screw Kit, spare part number 21, 22
- security cable slot, identifying 4
- security, product description 3
- serial number 13
- serial number, computer 13
- service considerations
  - cables 25
  - connectors 25
  - plastic parts 25
- service tag 13
- serviceability, product description 3
- slots
  - memory card reader 4
  - security cable 4
- solid-state drive
  - removal 38
  - spare part numbers 16, 20, 38
  - specifications 68
- Solid-state Drive Hardware Kit
  - spare part number 16, 23, 38
- Solid-state Drive Hardware Kit, spare part number 20

- Speaker Kit, spare part number 16, 22, 42
- speakers
  - identifying 10
  - removal 42
  - spare part number 16, 22, 42
- specifications
  - computer 67
  - hard drive 68
  - solid-state drive 68
- supported discs
  - recovery 69
- system board
  - removal 49
  - spare part numbers 17, 23, 49
- system recovery 71
- system restore point
  - creating 69

**T**

- tools required 25
- top cover
  - removal 30
  - spare part number 23, 30
- touch cable, spare part number 19
- TouchPad
  - buttons 8
  - control zone 8
- touchpad board
  - removal 35
  - spare part number 22, 35
- TouchPad zone, identifying 8
- transporting guidelines 27
- traveling with the computer 13

**U**

- USB 2.0 port, identifying 5
- USB 3.0 ports, identifying 4
- USB/audio board
  - removing 44
  - spare part number 16, 22, 44

**V**

- vents, identifying 5, 12
- video, product description 2
- volume button, identifying 5

**W**

- webcam
  - identifying 6
  - spare part number 22

- webcam light, identifying 6
- webcam, spare part number 19
- webcam/microphone module
  - removing 57
- Windows
  - File History 70
  - restoring files 70
  - system restore point 69
- Windows key, identifying 11
- wireless certification label 13
- wireless, product description 2
- WLAN antennas, identifying 6
- WLAN device 13
- WLAN label 13
- WLAN module
  - removal 40
  - spare part numbers 17, 21, 22, 40
- workstation guidelines 27