

HP DL380Z Gen9 Virtual Workstation Maintenance and Service Guide

Abstract

This guide describes identification and maintenance procedures, diagnostic tools, specifications, and requirements for hardware components and software. This guide is for an experienced service technician. HP assumes you are qualified in the servicing of computer equipment, trained in recognizing hazards in products, and are familiar with weight and stability precautions.



Part Number: 792112-001
December 2014
Edition: 1

© Copyright 2014 Hewlett-Packard Development Company, L.P.

The information contained herein is subject to change without notice. The only warranties for HP products and services are set forth in the express warranty statements accompanying such products and services. Nothing herein should be construed as constituting an additional warranty. HP shall not be liable for technical or editorial errors or omissions contained herein.

Microsoft®, Windows®, and Windows Server® are U.S. registered trademarks of the Microsoft group of companies.

Intel® Xeon® is a trademark of Intel Corporation in the U.S. and other countries.

Contents

Customer self repair	5
Parts only warranty service	5
Illustrated parts catalog	15
Mechanical components.....	15
System components	19
Removal and replacement procedures.....	25
Required tools.....	25
Preparation procedures.....	25
Power down the server.....	25
Extend the server from the rack.....	26
Remove the server from the rack.....	26
Access the product rear panel.....	27
Access the optional HP Systems Insight Display	28
Release the full-length expansion board retainer	28
Safety considerations.....	29
Preventing electrostatic discharge	29
Symbols on equipment	29
Server warnings and cautions	30
Access panel.....	31
Air baffle	31
PCIe riser blank.....	32
Primary PCIe riser cage.....	33
Secondary PCIe riser cage	34
PCIe riser board.....	35
Drive blank.....	36
Hot-plug drive	36
Power supply blank	37
AC power supply	37
Optical drive	38
Hot-plug fan	41
Fan cage.....	41
FlexibleLOM	42
8-SFF drive cage	43
2-SFF front drive cage.....	44
Universal media bay.....	45
8-SFF drive backplane	46
Systems Insight Display	47
Expansion slot blanks.....	48
Expansion boards	50
Full length expansion board.....	50
Half-length expansion board.....	51
Heatsink.....	52
Processor	54
DIMMs.....	57
HP Smart Storage Battery	57
HP Flexible Smart Array Controller	58
System battery	59
System board	60
HP Trusted Platform Module.....	66

Cabling	67
Eight-bay SFF front drive cage cabling	67
Universal media bay cabling	68
150W PCIe power cable option	69
Diagnostic tools	70
HP UEFI System Utilities	70
Using HP UEFI System Utilities	70
Flexible boot control	71
Restoring and customizing configuration settings	71
Secure Boot configuration	71
Embedded UEFI shell	72
Embedded Diagnostics option	72
HP RESTful API support for UEFI	72
Re-entering the server serial number and product ID	72
HP Pre-boot Health Summary	73
HP Insight Diagnostics	73
HP Insight Diagnostics survey functionality	73
Active Health System	74
Integrated Management Log	75
USB support	75
External USB functionality	75
Internal USB functionality	75
Troubleshooting	76
Troubleshooting resources	76
Component identification	77
Front panel components	77
Front panel LEDs and buttons	79
Power fault LEDs	81
Systems Insight Display LEDs	81
Systems Insight Display LED combinations	82
Rear panel components	83
Rear panel LEDs	84
Non-hot-plug PCI riser board slot definitions	84
System board components	85
System maintenance switch	86
NMI functionality	87
DIMM slot locations	87
SAS and SATA device numbers	88
Hot-plug drive LED definitions	90
Hot-plug fans	91
Specifications	93
Environmental specifications	93
Mechanical specifications	93
Power supply specifications	94
HP 500W Flex Slot Platinum Hot-plug Power Supply	95
HP 800W Flex Slot Platinum Hot-plug Power Supply	95
HP 1400W Flex Slot Platinum Plus Hot-plug Power Supply	96
Acronyms and abbreviations	97
Documentation feedback	99
Index	100

Customer self repair

HP products are designed with many Customer Self Repair (CSR) parts to minimize repair time and allow for greater flexibility in performing defective parts replacement. If during the diagnosis period HP (or HP service providers or service partners) identifies that the repair can be accomplished by the use of a CSR part, HP will ship that part directly to you for replacement. There are two categories of CSR parts:

- **Mandatory**—Parts for which customer self repair is mandatory. If you request HP to replace these parts, you will be charged for the travel and labor costs of this service.
- **Optional**—Parts for which customer self repair is optional. These parts are also designed for customer self repair. If, however, you require that HP replace them for you, there may or may not be additional charges, depending on the type of warranty service designated for your product.

NOTE: Some HP parts are not designed for customer self repair. In order to satisfy the customer warranty, HP requires that an authorized service provider replace the part. These parts are identified as "No" in the Illustrated Parts Catalog.

Based on availability and where geography permits, CSR parts will be shipped for next business day delivery. Same day or four-hour delivery may be offered at an additional charge where geography permits. If assistance is required, you can call the HP Technical Support Center and a technician will help you over the telephone. HP specifies in the materials shipped with a replacement CSR part whether a defective part must be returned to HP. In cases where it is required to return the defective part to HP, you must ship the defective part back to HP within a defined period of time, normally five (5) business days. The defective part must be returned with the associated documentation in the provided shipping material. Failure to return the defective part may result in HP billing you for the replacement. With a customer self repair, HP will pay all shipping and part return costs and determine the courier/carrier to be used.

For more information about HP's Customer Self Repair program, contact your local service provider. For the North American program, refer to the HP website (<http://www.hp.com/go/selfrepair>).

Parts only warranty service

Your HP Limited Warranty may include a parts only warranty service. Under the terms of parts only warranty service, HP will provide replacement parts free of charge.

For parts only warranty service, CSR part replacement is mandatory. If you request HP to replace these parts, you will be charged for the travel and labor costs of this service.

Réparation par le client (CSR)

Les produits HP comportent de nombreuses pièces CSR (Customer Self Repair = réparation par le client) afin de minimiser les délais de réparation et faciliter le remplacement des pièces défectueuses. Si pendant la période de diagnostic, HP (ou ses partenaires ou mainteneurs agréés) détermine que la réparation peut être effectuée à l'aide d'une pièce CSR, HP vous l'envoie directement. Il existe deux catégories de pièces CSR:

Obligatoire - Pièces pour lesquelles la réparation par le client est obligatoire. Si vous demandez à HP de remplacer ces pièces, les coûts de déplacement et main d'œuvre du service vous seront facturés.

Facultatif - Pièces pour lesquelles la réparation par le client est facultative. Ces pièces sont également conçues pour permettre au client d'effectuer lui-même la réparation. Toutefois, si vous demandez à HP de remplacer ces pièces, l'intervention peut ou non vous être facturée, selon le type de garantie applicable à votre produit.

REMARQUE: Certaines pièces HP ne sont pas conçues pour permettre au client d'effectuer lui-même la réparation. Pour que la garantie puisse s'appliquer, HP exige que le remplacement de la pièce soit effectué par un Mainteneur Agréé. Ces pièces sont identifiées par la mention "Non" dans le Catalogue illustré.

Les pièces CSR sont livrées le jour ouvré suivant, dans la limite des stocks disponibles et selon votre situation géographique. Si votre situation géographique le permet et que vous demandez une livraison le jour même ou dans les 4 heures, celle-ci vous sera facturée. Pour bénéficier d'une assistance téléphonique, appelez le Centre d'assistance technique HP. Dans les documents envoyés avec la pièce de rechange CSR, HP précise s'il est nécessaire de lui retourner la pièce défectueuse. Si c'est le cas, vous devez le faire dans le délai indiqué, généralement cinq (5) jours ouvrés. La pièce et sa documentation doivent être retournées dans l'emballage fourni. Si vous ne retournez pas la pièce défectueuse, HP se réserve le droit de vous facturer les coûts de remplacement. Dans le cas d'une pièce CSR, HP supporte l'ensemble des frais d'expédition et de retour, et détermine la société de courses ou le transporteur à utiliser.

Pour plus d'informations sur le programme CSR de HP, contactez votre Mainteneur Agréé local. Pour plus d'informations sur ce programme en Amérique du Nord, consultez le site Web HP (<http://www.hp.com/go/selfrepair>).

Service de garantie "pièces seules"

Votre garantie limitée HP peut inclure un service de garantie "pièces seules". Dans ce cas, les pièces de rechange fournies par HP ne sont pas facturées.

Dans le cadre de ce service, la réparation des pièces CSR par le client est obligatoire. Si vous demandez à HP de remplacer ces pièces, les coûts de déplacement et main d'œuvre du service vous seront facturés.

Riparazione da parte del cliente

Per abbreviare i tempi di riparazione e garantire una maggiore flessibilità nella sostituzione di parti difettose, i prodotti HP sono realizzati con numerosi componenti che possono essere riparati direttamente dal cliente (CSR, Customer Self Repair). Se in fase di diagnostica HP (o un centro di servizi o di assistenza HP) identifica il guasto come riparabile mediante un ricambio CSR, HP lo spedisce direttamente al cliente per la sostituzione. Vi sono due categorie di parti CSR:

Obbligatorie – Parti che devono essere necessariamente riparate dal cliente. Se il cliente ne affida la riparazione ad HP, deve sostenere le spese di spedizione e di manodopera per il servizio.

Opzionali – Parti la cui riparazione da parte del cliente è facoltativa. Si tratta comunque di componenti progettati per questo scopo. Se tuttavia il cliente ne richiede la sostituzione ad HP, potrebbe dover sostenere spese aggiuntive a seconda del tipo di garanzia previsto per il prodotto.

NOTA: alcuni componenti HP non sono progettati per la riparazione da parte del cliente. Per rispettare la garanzia, HP richiede che queste parti siano sostituite da un centro di assistenza autorizzato. Tali parti sono identificate da un "No" nel Catalogo illustrato dei componenti.

In base alla disponibilità e alla località geografica, le parti CSR vengono spedite con consegna entro il giorno lavorativo seguente. La consegna nel giorno stesso o entro quattro ore è offerta con un supplemento di costo solo in alcune zone. In caso di necessità si può richiedere l'assistenza telefonica di un addetto del centro di supporto tecnico HP. Nel materiale fornito con una parte di ricambio CSR, HP specifica se il cliente deve restituire dei componenti. Qualora sia richiesta la resa ad HP del componente difettoso, lo si deve spedire ad HP entro un determinato periodo di tempo, generalmente cinque (5) giorni lavorativi. Il componente difettoso deve essere restituito con la documentazione associata nell'imballo di spedizione fornito. La mancata restituzione del componente può comportare la fatturazione del ricambio da parte di HP. Nel caso di riparazione da parte del cliente, HP sostiene tutte le spese di spedizione e resa e sceglie il corriere/vettore da utilizzare.

Per ulteriori informazioni sul programma CSR di HP contattare il centro di assistenza di zona. Per il programma in Nord America fare riferimento al sito Web HP (<http://www.hp.com/go/selfrepair>).

Servizio di garanzia per i soli componenti

La garanzia limitata HP può includere un servizio di garanzia per i soli componenti. Nei termini di garanzia del servizio per i soli componenti, HP fornirà gratuitamente le parti di ricambio.

Per il servizio di garanzia per i soli componenti è obbligatoria la formula CSR che prevede la riparazione da parte del cliente. Se il cliente invece richiede la sostituzione ad HP, dovrà sostenere le spese di spedizione e di manodopera per il servizio.

Customer Self Repair

HP Produkte enthalten viele CSR-Teile (Customer Self Repair), um Reparaturzeiten zu minimieren und höhere Flexibilität beim Austausch defekter Bauteile zu ermöglichen. Wenn HP (oder ein HP Servicepartner) bei der Diagnose feststellt, dass das Produkt mithilfe eines CSR-Teils repariert werden kann, sendet Ihnen HP dieses Bauteil zum Austausch direkt zu. CSR-Teile werden in zwei Kategorien unterteilt:

Zwingend – Teile, für die das Customer Self Repair-Verfahren zwingend vorgegeben ist. Wenn Sie den Austausch dieser Teile von HP vornehmen lassen, werden Ihnen die Anfahrt- und Arbeitskosten für diesen Service berechnet.

Optional – Teile, für die das Customer Self Repair-Verfahren optional ist. Diese Teile sind auch für Customer Self Repair ausgelegt. Wenn Sie jedoch den Austausch dieser Teile von HP vornehmen lassen möchten, können bei diesem Service je nach den für Ihr Produkt vorgesehenen Garantiebedingungen zusätzliche Kosten anfallen.

HINWEIS: Einige Teile sind nicht für Customer Self Repair ausgelegt. Um den Garantieanspruch des Kunden zu erfüllen, muss das Teil von einem HP Servicepartner ersetzt werden. Im illustrierten Teilekatalog sind diese Teile mit „No“ bzw. „Nein“ gekennzeichnet.

CSR-Teile werden abhängig von der Verfügbarkeit und vom Lieferziel am folgenden Geschäftstag geliefert. Für bestimmte Standorte ist eine Lieferung am selben Tag oder innerhalb von vier Stunden gegen einen Aufpreis verfügbar. Wenn Sie Hilfe benötigen, können Sie das HP technische Support Center anrufen und sich von einem Mitarbeiter per Telefon helfen lassen. Den Materialien, die mit einem CSR-Ersatzteil geliefert werden, können Sie entnehmen, ob das defekte Teil an HP zurückgeschickt werden muss. Wenn es erforderlich ist, das defekte Teil an HP zurückzuschicken, müssen Sie dies innerhalb eines vorgegebenen Zeitraums tun, in der Regel innerhalb von fünf (5) Geschäftstagen. Das defekte Teil muss mit der zugehörigen Dokumentation in der Verpackung zurückgeschickt werden, die im Lieferumfang enthalten ist. Wenn Sie das

defekte Teil nicht zurückschicken, kann HP Ihnen das Ersatzteil in Rechnung stellen. Im Falle von Customer Self Repair kommt HP für alle Kosten für die Lieferung und Rücksendung auf und bestimmt den Kurier-/Frachtdienst.

Weitere Informationen über das HP Customer Self Repair Programm erhalten Sie von Ihrem Servicepartner vor Ort. Informationen über das CSR-Programm in Nordamerika finden Sie auf der HP Website unter (<http://www.hp.com/go/selfrepair>).

Parts-only Warranty Service (Garantieservice ausschließlich für Teile)

Ihre HP Garantie umfasst möglicherweise einen Parts-only Warranty Service (Garantieservice ausschließlich für Teile). Gemäß den Bestimmungen des Parts-only Warranty Service stellt HP Ersatzteile kostenlos zur Verfügung.

Für den Parts-only Warranty Service ist das CSR-Verfahren zwingend vorgegeben. Wenn Sie den Austausch dieser Teile von HP vornehmen lassen, werden Ihnen die Anfahrt- und Arbeitskosten für diesen Service berechnet.

Reparaciones del propio cliente

Los productos de HP incluyen muchos componentes que el propio usuario puede reemplazar (*Customer Self Repair*, CSR) para minimizar el tiempo de reparación y ofrecer una mayor flexibilidad a la hora de realizar sustituciones de componentes defectuosos. Si, durante la fase de diagnóstico, HP (o los proveedores o socios de servicio de HP) identifica que una reparación puede llevarse a cabo mediante el uso de un componente CSR, HP le enviará dicho componente directamente para que realice su sustitución. Los componentes CSR se clasifican en dos categorías:

- **Obligatorio:** componentes para los que la reparación por parte del usuario es obligatoria. Si solicita a HP que realice la sustitución de estos componentes, tendrá que hacerse cargo de los gastos de desplazamiento y de mano de obra de dicho servicio.
- **Opcional:** componentes para los que la reparación por parte del usuario es opcional. Estos componentes también están diseñados para que puedan ser reparados por el usuario. Sin embargo, si precisa que HP realice su sustitución, puede o no conllevar costes adicionales, dependiendo del tipo de servicio de garantía correspondiente al producto.

NOTA: Algunos componentes no están diseñados para que puedan ser reparados por el usuario. Para que el usuario haga valer su garantía, HP pone como condición que un proveedor de servicios autorizado realice la sustitución de estos componentes. Dichos componentes se identifican con la palabra "No" en el catálogo ilustrado de componentes.

Según la disponibilidad y la situación geográfica, los componentes CSR se enviarán para que lleguen a su destino al siguiente día laborable. Si la situación geográfica lo permite, se puede solicitar la entrega en el mismo día o en cuatro horas con un coste adicional. Si precisa asistencia técnica, puede llamar al Centro de asistencia técnica de HP y recibirá ayuda telefónica por parte de un técnico. Con el envío de materiales para la sustitución de componentes CSR, HP especificará si los componentes defectuosos deberán devolverse a HP. En aquellos casos en los que sea necesario devolver algún componente a HP, deberá hacerlo en el periodo de tiempo especificado, normalmente cinco días laborables. Los componentes defectuosos deberán devolverse con toda la documentación relacionada y con el embalaje de envío. Si no

enviara el componente defectuoso requerido, HP podrá cobrarle por el de sustitución. En el caso de todas sustituciones que lleve a cabo el cliente, HP se hará cargo de todos los gastos de envío y devolución de componentes y escogerá la empresa de transporte que se utilice para dicho servicio.

Para obtener más información acerca del programa de Reparaciones del propio cliente de HP, póngase en contacto con su proveedor de servicios local. Si está interesado en el programa para Norteamérica, visite la página web de HP siguiente (<http://www.hp.com/go/selfrepair>).

Servicio de garantía exclusivo de componentes

La garantía limitada de HP puede que incluya un servicio de garantía exclusivo de componentes. Según las condiciones de este servicio exclusivo de componentes, HP le facilitará los componentes de repuesto sin cargo adicional alguno.

Para este servicio de garantía exclusivo de componentes, es obligatoria la sustitución de componentes por parte del usuario (CSR). Si solicita a HP que realice la sustitución de estos componentes, tendrá que hacerse cargo de los gastos de desplazamiento y de mano de obra de dicho servicio.

Customer Self Repair

Veel onderdelen in HP producten zijn door de klant zelf te repareren, waardoor de reparatieduur tot een minimum beperkt kan blijven en de flexibiliteit in het vervangen van defecte onderdelen groter is. Deze onderdelen worden CSR-onderdelen (Customer Self Repair) genoemd. Als HP (of een HP Service Partner) bij de diagnose vaststelt dat de reparatie kan worden uitgevoerd met een CSR-onderdeel, verzendt HP dat onderdeel rechtstreeks naar u, zodat u het defecte onderdeel daarmee kunt vervangen. Er zijn twee categorieën CSR-onderdelen:

Verplicht: Onderdelen waarvoor reparatie door de klant verplicht is. Als u HP verzoekt deze onderdelen voor u te vervangen, worden u voor deze service reiskosten en arbeidsloon in rekening gebracht.

Optioneel: Onderdelen waarvoor reparatie door de klant optioneel is. Ook deze onderdelen zijn ontworpen voor reparatie door de klant. Als u echter HP verzoekt deze onderdelen voor u te vervangen, kunnen daarvoor extra kosten in rekening worden gebracht, afhankelijk van het type garantieservice voor het product.

OPMERKING: Sommige HP onderdelen zijn niet ontwikkeld voor reparatie door de klant. In verband met de garantievoorwaarden moet het onderdeel door een geautoriseerde Service Partner worden vervangen. Deze onderdelen worden in de geïllustreerde onderdelencatalogus aangemerkt met "Nee".

Afhankelijk van de leverbaarheid en de locatie worden CSR-onderdelen verzonden voor levering op de eerstvolgende werkdag. Levering op dezelfde dag of binnen vier uur kan tegen meerkosten worden aangeboden, indien dit mogelijk is gezien de locatie. Indien assistentie gewenst is, belt u een HP Service Partner om via de telefoon technische ondersteuning te ontvangen. HP vermeldt in de documentatie bij het vervangende CSR-onderdeel of het defecte onderdeel aan HP moet worden geretourneerd. Als het defecte onderdeel aan HP moet worden teruggezonden, moet u het defecte onderdeel binnen een bepaalde periode, gewoonlijk vijf (5) werkdagen, retourneren aan HP. Het defecte onderdeel moet met de bijbehorende documentatie worden geretourneerd in het meegeleverde verpakkingsmateriaal. Als u het defecte onderdeel niet terugzendt, kan HP u voor het vervangende onderdeel kosten in rekening brengen. Bij reparatie door de klant betaalt HP alle verzendkosten voor het vervangende en geretourneerde onderdeel en kiest HP zelf welke koerier/transportonderneming hiervoor wordt gebruikt.

Neem contact op met een Service Partner voor meer informatie over het Customer Self Repair programma van HP. Informatie over Service Partners vindt u op de HP website (<http://www.hp.com/go/selfrepair>).

Garantieservice "Parts Only"

Het is mogelijk dat de HP garantie alleen de garantieservice "Parts Only" omvat. Volgens de bepalingen van de Parts Only garantieservice zal HP kosteloos vervangende onderdelen ter beschikking stellen.

Voor de Parts Only garantieservice is vervanging door CSR-onderdelen verplicht. Als u HP verzoekt deze onderdelen voor u te vervangen, worden u voor deze service reiskosten en arbeidsloon in rekening gebracht.

Reparo feito pelo cliente

Os produtos da HP são projetados com muitas peças para reparo feito pelo cliente (CSR) de modo a minimizar o tempo de reparo e permitir maior flexibilidade na substituição de peças com defeito. Se, durante o período de diagnóstico, a HP (ou fornecedores/parceiros de serviço da HP) concluir que o reparo pode ser efetuado pelo uso de uma peça CSR, a peça de reposição será enviada diretamente ao cliente. Existem duas categorias de peças CSR:

Obrigatória – Peças cujo reparo feito pelo cliente é obrigatório. Se desejar que a HP substitua essas peças, serão cobradas as despesas de transporte e mão-de-obra do serviço.

Opcional – Peças cujo reparo feito pelo cliente é opcional. Essas peças também são projetadas para o reparo feito pelo cliente. No entanto, se desejar que a HP as substitua, pode haver ou não a cobrança de taxa adicional, dependendo do tipo de serviço de garantia destinado ao produto.

OBSERVAÇÃO: Algumas peças da HP não são projetadas para o reparo feito pelo cliente. A fim de cumprir a garantia do cliente, a HP exige que um técnico autorizado substitua a peça. Essas peças estão identificadas com a marca "No" (Não), no catálogo de peças ilustrado.

Conforme a disponibilidade e o local geográfico, as peças CSR serão enviadas no primeiro dia útil após o pedido. Onde as condições geográficas permitirem, a entrega no mesmo dia ou em quatro horas pode ser feita mediante uma taxa adicional. Se precisar de auxílio, entre em contato com o Centro de suporte técnico da HP para que um técnico o ajude por telefone. A HP especifica nos materiais fornecidos com a peça CSR de reposição se a peça com defeito deve ser devolvida à HP. Nos casos em que isso for necessário, é preciso enviar a peça com defeito à HP dentro do período determinado, normalmente cinco (5) dias úteis. A peça com defeito deve ser enviada com a documentação correspondente no material de transporte fornecido. Caso não o faça, a HP poderá cobrar a reposição. Para as peças de reparo feito pelo cliente, a HP paga todas as despesas de transporte e de devolução da peça e determina a transportadora/serviço postal a ser utilizado.

Para obter mais informações sobre o programa de reparo feito pelo cliente da HP, entre em contato com o fornecedor de serviços local. Para o programa norte-americano, visite o site da HP (<http://www.hp.com/go/selfrepair>).

Serviço de garantia apenas para peças

A garantia limitada da HP pode incluir um serviço de garantia apenas para peças. Segundo os termos do serviço de garantia apenas para peças, a HP fornece as peças de reposição sem cobrar nenhuma taxa.

No caso desse serviço, a substituição de peças CSR é obrigatória. Se desejar que a HP substitua essas peças, serão cobradas as despesas de transporte e mão-de-obra do serviço.

カスタマーセルフリペア

修理時間を短縮し、故障部品の交換における高い柔軟性を確保するために、HP製品には多数のCSR部品があります。診断の際に、CSR部品を使用すれば修理ができるとHP（HPまたはHP正規保守代理店）が判断した場合、HPはその部品を直接、お客様に発送し、お客様に交換していただきます。CSR部品には以下の2通りがあります。

- **必須** - カスタマーセルフリペアが必須の部品。当該部品について、もしもお客様がHPに交換作業を依頼される場合には、その修理サービスに関する交通費および人件費がお客様に請求されます。
- **任意** - カスタマーセルフリペアが任意である部品。この部品もカスタマーセルフリペア用です。当該部品について、もしもお客様がHPに交換作業を依頼される場合には、お買い上げの製品に適用される保証サービス内容の範囲内においては、別途費用を負担していただくことなく保証サービスを受けることができます。

注： HP製品の一部の部品は、カスタマーセルフリペア用ではありません。製品の保証を継続するためには、HPまたはHP正規保守代理店による交換作業が必須となります。部品カタログには、当該部品がカスタマーセルフリペア除外品である旨が記載されています。

部品供給が可能な場合、地域によっては、CSR部品を翌営業日に届くように発送します。また、地域によっては、追加費用を負担いただくことにより同日または4時間以内に届くように発送することも可能な場合があります。サポートが必要なときは、HPの修理受付窓口にご連絡いただければ、技術者が電話でアドバイスします。交換用のCSR部品または同梱物には、故障部品をHPに返送する必要があるかどうかが表示されています。故障部品をHPに返送する必要がある場合は、指定期限内（通常は5営業日以内）に故障部品をHPに返送してください。故障部品を返送する場合は、届いた時の梱包箱に関連書類とともに入れてください。故障部品を返送しない場合、HPから部品費用が請求されます。カスタマーセルフリペアの際には、HPは送料および部品返送費を全額負担し、使用する宅配便会社や運送会社を指定します。

部品のみ保証サービス

HP保証サービスには、部品のみ保証サービスが適用される場合があります。このサービスでは、交換部品は無償で提供されます。

部品のみ保証サービスにおいては、CSR部品をお客様により交換作業していただくことが必須となります。当該部品について、もしもお客様がHPに交換作業を依頼される場合には、その修理サービスに関する交通費および人件費はお客様の負担となります。

客户自行维修

HP 产品提供许多客户自行维修 (CSR) 部件，以尽可能缩短维修时间和在更换缺陷部件方面提供更大的灵活性。如果在诊断期间 HP（或 HP 服务提供商或服务合作伙伴）确定可以通过使用 CSR 部件完成维修，HP 将直接把该部件发送给您进行更换。有两类 CSR 部件：

- **强制性的** — 要求客户必须自行维修的部件。如果您请求 HP 更换这些部件，则必须为该服务支付差旅费和人工费用。
- **可选的** — 客户可以选择是否自行维修的部件。这些部件也是为客户自行维修设计的。不过，如果您要求 HP 为您更换这些部件，则根据为您的产品指定的保修服务类型，HP 可能收取或不再收取任何附加费用。

注：某些 HP 部件的设计并未考虑客户自行维修。为了满足客户保修的需要，HP 要求授权服务提供商更换相关部件。这些部件在部件图解目录中标记为“否”。

CSR 部件将在下一个工作日发运（取决于备货情况和允许的地理范围）。在允许的地理范围内，可在当天或四小时内发运，但要收取额外费用。如果需要帮助，您可以致电 HP 技术支持中心，将会有技术人员通过电话为您提供帮助。HP 会在随更换的 CSR 部件发运的材料中指明是否必须将有缺陷的部件返还给 HP。如果要求您将有缺陷的部件返还给 HP，那么您必须在规定期限内（通常是五 (5) 个工作日）将缺陷部件发给 HP。有缺陷的部件必须随所提供的发运材料中的相关文件一起返还。如果未能送还缺陷的部件，HP 可能会要求您支付更换费用。客户自行维修时，HP 将承担所有相关运输和部件返回费用，并指定快递商/承运商。

有关 HP 客户自行维修计划的详细信息，请与您当地的服务提供商联系。有关北美地区的计划，请访问 HP 网站 (<http://www.hp.com/go/selfrepair>)。

仅部件保修服务

您的 HP 有限保修服务可能涉及仅部件保修服务。根据仅部件保修服务条款的规定，HP 将免费提供更换的部件。

仅部件保修服务要求进行 CSR 部件更换。如果您请求 HP 更换这些部件，则必须为该服务支付差旅费和人工费用。

客戶自行維修

HP 產品設計了許多「客戶自行維修」(CSR) 的零件以減少維修時間，並且使得更換瑕疵零件時能有更大的彈性。如果在診斷期間 HP (或 HP 服務供應商或維修夥伴) 辨認出此項維修工作可以藉由使用 CSR 零件來完成，則 HP 將直接寄送該零件給您作更換。CSR 零件分為兩種類別：

- **強制的** — 客戶自行維修所使用的零件是強制性的。如果您要求 HP 更換這些零件，HP 將會向您收取此服務所需的外出費用與勞動成本。
- **選購的** — 客戶自行維修所使用的零件是選購的。這些零件也設計用於客戶自行維修之用。不過，如果您要求 HP 為您更換，則可能需要也可能不需要負擔額外的費用，端視針對此產品指定的保固服務類型而定。

備註：某些 HP 零件沒有消費者可自行維修的設計。為符合客戶保固，HP 需要授權的服務供應商更換零件。這些零件在圖示的零件目錄中，被標示為「否」。

基於材料取得及環境允許的情況下，CSR 零件將於下一個工作日以快遞寄送。在環境的允許下當天或四小時內送達，則可能需要額外的費用。若您需要協助，可致電「HP 技術支援中心」，會有一位技術人員透過電話來協助您。不論損壞的零件是否必須退回，HP 皆會在與 CSR 替換零件一起運送的材料中註明。若要將損壞的零件退回 HP，您必須在指定的一段時間內（通常為五 (5) 個工作天），將損壞的零件寄回 HP。損壞的零件必須與寄送資料中隨附的相關技術文件一併退還。如果無法退還損壞的零件，HP 可能要向您收取替換費用。針對客戶自行維修情形，HP 將負責所有運費及零件退還費用並指定使用何家快遞/貨運公司。

如需 HP 的「客戶自行維修」方案詳細資訊，請連絡您當地的服務供應商。至於北美方案，請參閱 HP 網站 (<http://www.hp.com/go/selfrepair>)。

僅限零件的保固服務

您的「HP 有限保固」可能包含僅限零件的保固服務。在僅限零件的保固服務情況下，HP 將免費提供替換零件。

針對僅限零件的保固服務，CSR 零件替換是強制性的。如果您要求 HP 更換這些零件，HP 將會向您收取此服務所需的外出費用與勞動成本。

고객 셀프 수리

HP 제품은 수리 시간을 최소화하고 결함이 있는 부품 교체 시 더욱 융통성을 발휘할 수 있도록 하기 위해 고객 셀프 수리(CSR) 부품을 다량 사용하여 설계되었습니다. 진단 기간 동안 HP(또는 HP 서비스 공급업체 또는 서비스 협력업체)에서 CSR 부품을 사용하여 수리가 가능하다고 판단되면 HP는 해당 부품을 바로 사용자에게 보내어 사용자가 교체할 수 있도록 합니다. CSR 부품에는 두 가지 종류가 있습니다.

- **고객 셀프 수리가 의무 사항인 필수 부품.** 사용자가 HP에 이 부품의 교체를 요청할 경우 이 서비스에 대한 출장비 및 작업비가 청구됩니다.
- **고객 셀프 수리가 선택 사항인 부품.** 이 부품들도 고객 셀프 수리가 가능하도록 설계되었습니다. 하지만 사용자가 HP에 이 부품의 교체를 요청할 경우 사용자가 구입한 제품에 해당하는 보증 서비스 유형에 따라 추가 비용 없이 교체가 가능할 수 있습니다.

참고: 일부 HP 부품은 고객 셀프 수리가 불가능하도록 설계되었습니다. HP는 만족스러운 고객 보증을 위해 공인 서비스 제공업체를 통해 부품을 교체하도록 하고 있습니다. 이러한 부품들은 Illustrated Parts Catalog에 "No"라고 표시되어 있습니다.

CSR 부품은 재고 상태와 지리적 조건이 허용하는 경우 다음 영업일 납품이 가능하도록 배송이 이루어집니다. 지리적 조건이 허용하는 경우 추가 비용이 청구되는 조건으로 당일 또는 4시간 배송이 가능할 수도 있습니다. 도움이 필요하시면 HP 기술 지원 센터로 전화하십시오. 전문 기술자가 전화로 도움을 줄 것입니다. HP는 결함이 발생한 부품을 HP로 반환해야 하는지 여부를 CSR 교체 부품과 함께 배송된 자료에 지정합니다. 결함이 발생한 부품을 HP로 반환해야 하는 경우에는 지정된 기간 내(통상 영업일 기준 5일)에 HP로 반환해야 합니다. 이 때 결함이 발생한 부품은 제공된 포장 재료에 넣어 관련 설명서와 함께 반환해야 합니다. 결함이 발생한 부품을 반환하지 않는 경우 HP가 교체 부품에 대해 비용을 청구할 수 있습니다. 고객 셀프 수리의 경우, HP는 모든 운송 및 부품 반환 비용을 부담하며 이용할 운송업체 및 택배 서비스를 결정합니다.

HP 고객 셀프 수리 프로그램에 대한 자세한 내용은 가까운 서비스 제공업체에 문의하십시오. 북미 지역의 프로그램에 대해서는 HP 웹 사이트(<http://www.hp.com/go/selfrepair>)를 참조하십시오.

부품 제공 보증 서비스

HP 제한 보증에는 부품 제공 보증 서비스가 포함될 수 있습니다. 이러한 경우 HP는 부품 제공 보증 서비스의 조건에 따라 교체 부품만을 무료로 제공합니다.

부품 제공 보증 서비스 제공 시 CSR 부품 교체는 의무 사항입니다. 사용자가 HP에 이 부품의 교체를 요청할 경우 이 서비스에 대한 출장비 및 작업비가 청구됩니다.

Illustrated parts catalog

Mechanical components

HP continually improves and changes product parts. For complete and current supported parts information, see one of the following websites:

- HP PartSurfer website (<http://partsurfer.hp.com>)
- HP PartSurfer mobile site (<http://partsurfermobile.hp.com>)

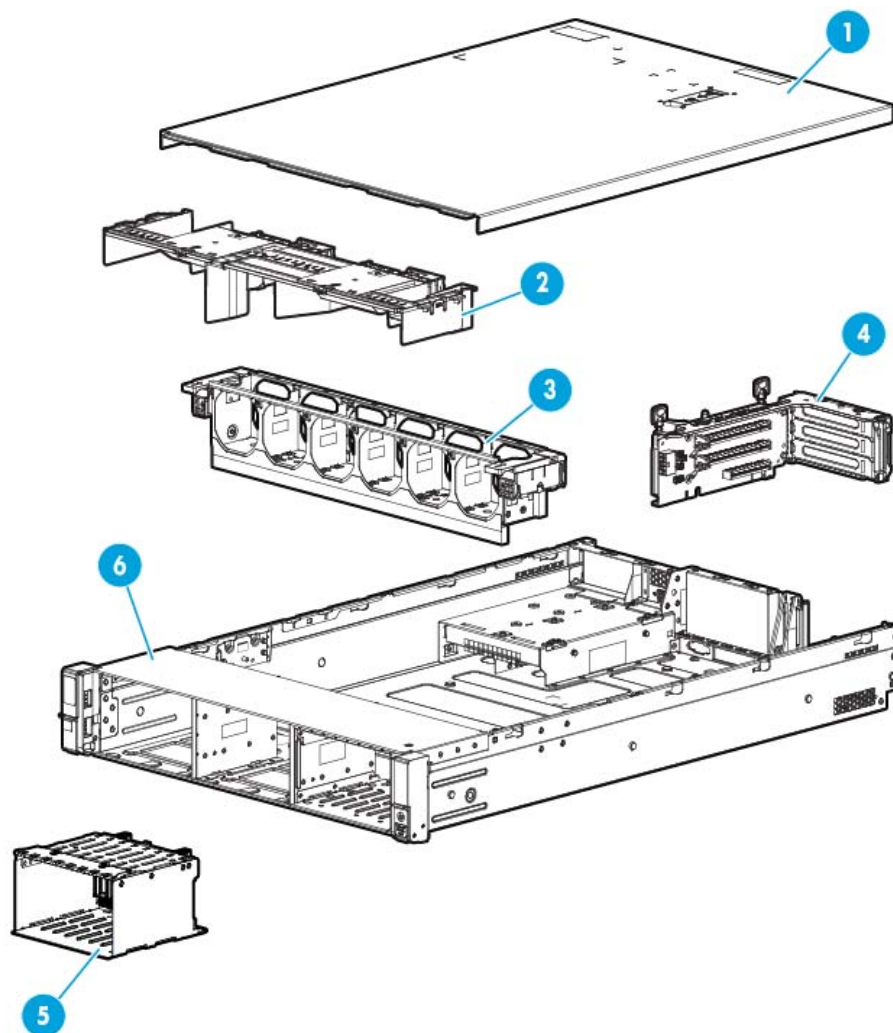

Item	Description	Spare part number	Customer self repair (on page 5)
1	Access panel	777292-001	Mandatory
2	Air baffle kit	777302-001	Mandatory ¹
3	Fan cage	777294-001	Mandatory ¹
4	PCI riser cage	—	—
	a) PCI riser cage, standard primary	777281-001	Optional ²
	b) PCI riser cage, primary optional*	777282-001	Optional ²
	c) PCI riser cage, secondary optional*	777283-001	Optional ²
5	Drive cage, 8SFF	779086-001	Mandatory ¹
6	Rail kit*	—	—
	a) SFF 2U easy install rail kit	744114-001	Mandatory ¹
	b) 2U cable management arm	744116-001	Mandatory ¹
7	Universal media bay*	786579-001	Mandatory ¹
8	Miscellaneous blanks kit*	777301-001	—
	a) Power supply blank	—	Mandatory ¹
	b) Drive blank	—	Mandatory ¹
	c) PCI riser blank	—	Mandatory ¹
	d) HP Flexible Smart Array Controller blank	—	Mandatory ¹
	e) Fan blank	—	Mandatory ¹

* Not shown

¹Mandatory—Parts for which customer self repair is mandatory. If you request HP to replace these parts, you will be charged for the travel and labor costs of this service.

²Optional—Parts for which customer self repair is optional. These parts are also designed for customer self repair. If, however, you require that HP replace them for you, there may or may not be additional charges, depending on the type of warranty service designated for your product.

³No—Some HP parts are not designed for customer self repair. In order to satisfy the customer warranty, HP requires that an authorized service provider replace the part. These parts are identified as "No" in the Illustrated Parts Catalog.

¹Mandatory: Obligatoire—Pièces pour lesquelles la réparation par le client est obligatoire. Si vous demandez à HP de remplacer ces pièces, les coûts de déplacement et main d'œuvre du service vous seront facturés.

²Optional: Facultatif—Pièces pour lesquelles la réparation par le client est facultative. Ces pièces sont également conçues pour permettre au client d'effectuer lui-même la réparation. Toutefois, si vous demandez à HP de remplacer ces pièces, l'intervention peut ou non vous être facturée, selon le type de garantie applicable à votre produit.

³No: Non—Certaines pièces HP ne sont pas conçues pour permettre au client d'effectuer lui-même la réparation. Pour que la garantie puisse s'appliquer, HP exige que le remplacement de la pièce soit effectué par un Mainteneur Agréé. Ces pièces sont identifiées par la mention "Non" dans le Catalogue illustré.

¹Mandatory: Obbligatorie—Parti che devono essere necessariamente riparate dal cliente. Se il cliente ne affida la riparazione ad HP, deve sostenere le spese di spedizione e di manodopera per il servizio.

²Optional: Opzionali—Parti la cui riparazione da parte del cliente è facoltativa. Si tratta comunque di componenti progettati per questo scopo. Se tuttavia il cliente ne richiede la sostituzione ad HP, potrebbe dover sostenere spese addizionali a seconda del tipo di garanzia previsto per il prodotto.

³No: Non CSR—Alcuni componenti HP non sono progettati per la riparazione da parte del cliente. Per rispettare la garanzia, HP richiede che queste parti siano sostituite da un centro di assistenza autorizzato. Tali parti sono identificate da un "No" nel Catalogo illustrato dei componenti.

¹Mandatory: Zwingend—Teile, die im Rahmen des Customer Self Repair Programms ersetzt werden müssen. Wenn Sie diese Teile von HP ersetzen lassen, werden Ihnen die Versand- und Arbeitskosten für diesen Service berechnet.

²Optional: Optional—Teile, für die das Customer Self Repair-Verfahren optional ist. Diese Teile sind auch für Customer Self Repair ausgelegt. Wenn Sie jedoch den Austausch dieser Teile von HP vornehmen lassen möchten, können bei diesem Service je nach den für Ihr Produkt vorgesehenen Garantiebedingungen zusätzliche Kosten anfallen.

³No: Kein—Einige Teile sind nicht für Customer Self Repair ausgelegt. Um den Garantieanspruch des Kunden zu erfüllen, muss das Teil von einem HP Servicepartner ersetzt werden. Im illustrierten Teilekatalog sind diese Teile mit „No“ bzw. „Nein“ gekennzeichnet.

¹Mandatory: Obligatorio—componentes para los que la reparación por parte del usuario es obligatoria. Si solicita a HP que realice la sustitución de estos componentes, tendrá que hacerse cargo de los gastos de desplazamiento y de mano de obra de dicho servicio.

²Optional: Opcional— componentes para los que la reparación por parte del usuario es opcional. Estos componentes también están diseñados para que puedan ser reparados por el usuario. Sin embargo, si precisa que HP realice su sustitución, puede o no conllevar costes adicionales, dependiendo del tipo de servicio de garantía correspondiente al producto.

³No: No—Algunos componentes no están diseñados para que puedan ser reparados por el usuario. Para que el usuario haga valer su garantía, HP pone como condición que un proveedor de servicios autorizado realice la sustitución de estos componentes. Dichos componentes se identifican con la palabra “No” en el catálogo ilustrado de componentes.

¹Mandatory: Verplicht—Onderdelen waarvoor Customer Self Repair verplicht is. Als u HP verzoekt deze onderdelen te vervangen, komen de reiskosten en het arbeidsloon voor uw rekening.

²Optional: Optioneel—Onderdelen waarvoor reparatie door de klant optioneel is. Ook deze onderdelen zijn ontworpen voor reparatie door de klant. Als u echter HP verzoekt deze onderdelen voor u te vervangen, kunnen daarvoor extra kosten in rekening worden gebracht, afhankelijk van het type garantieservice voor het product.

³No: Nee—Sommige HP onderdelen zijn niet ontwikkeld voor reparatie door de klant. In verband met de garantiev voorwaarden moet het onderdeel door een geautoriseerde Service Partner worden vervangen. Deze onderdelen worden in de geïllustreerde onderdelen catalogus aangemerkt met "Nee".

¹Mandatory: Obrigatória—Peças cujo reparo feito pelo cliente é obrigatório. Se desejar que a HP substitua essas peças, serão cobradas as despesas de transporte e mão-de-obra do serviço.

²Optional: Opcional—Peças cujo reparo feito pelo cliente é opcional. Essas peças também são projetadas para o reparo feito pelo cliente. No entanto, se desejar que a HP as substitua, pode haver ou não a cobrança de taxa adicional, dependendo do tipo de serviço de garantia destinado ao produto.

³No: Nenhuma—Algumas peças da HP não são projetadas para o reparo feito pelo cliente. A fim de cumprir a garantia do cliente, a HP exige que um técnico autorizado substitua a peça. Essas peças estão identificadas com a marca “No” (Não), no catálogo de peças ilustrado.

¹Mandatory : 必須 - 顧客自己修理が必須の部品。当該部品について、もしもお客様がHPに交換作業を依頼される場合には、その修理サービスに関する交通費および人件費がお客様に請求されます。

²Optional : 任意 - 顧客自己修理が任意である部品。この部品も顧客自己修理用です。当該部品について、もしもお客様がHPに交換作業を依頼される場合には、お買い上げの製品に適用される保証サービス内容の範囲内においては、費用を負担していただくことなく保証サービスを受けることができます。

³No : 除外 - HP製品の一部の部品は、顧客自己修理用ではありません。製品の保証を継続するためには、HPまたはHP正規保守代理店による交換作業が必須となります。部品カタログには、当該部品が顧客自己修理除外品である旨が記載されています。

¹Mandatory: 强制性的 — 要求客户必须自行维修的部件。如果您请求 HP 更换这些部件，则必须为该服务支付差旅费和人工费用。

²Optional: 可选的 — 客户可以选择是否自行维修的部件。这些部件也是为客户自行维修设计的。不过，如果您要求 HP 为您更换这些部件，则根据您的产品指定的保修服务类型，HP 可能收取或不再收取任何附加费用。

³No: 否 — 某些 HP 部件的设计并未考虑客户自行维修。为了满足客户保修的需要，HP 要求授权服务提供商更换相关部件。这些部件在部件图解目录中标记为“否”。

¹Mandatory: 強制的 — 客戶自行維修所使用的零件是強制性的。如果您要求 HP 更換這些零件，HP 將會向您收取此服務所需的外出費用與勞動成本。

²Optional: 選購的 — 客戶自行維修所使用的零件是選購的。這些零件也設計用於客戶自行維修之用。不過，如果您要求 HP 為您更換，則可能需要也可能不需要負擔額外的費用，端視針對此產品指定的保固服務類型而定。

³No: 否 — 某些 HP 零件沒有消費者可自行維修的設計。為符合客戶保固，HP 需要授權的服務供應商更換零件。這些零件在圖示的零件目錄中，被標示為「否」。

¹ Mandatory: 필수 — 고객 셀프 수리가 의무 사항인 필수 부품. 사용자가 HP에 이 부품의 교체를 요청할 경우 이 서비스에 대한 출장비 및 작업비가 청구됩니다.

² Optional: 옵션 — 고객 셀프 수리가 선택 사항인 부품. 이 부품들도 고객 셀프 수리가 가능하도록 설계되었습니다. 하지만 사용자가 HP에 이 부품의 교체를 요청할 경우 사용자가 구입한 제품에 해당하는 보증 서비스 유형에 따라 추가 비용 없이 교체가 가능할 수 있습니다.

³ No: No — 고객 셀프 수리가 불가능하도록 설계된 HP 부품. 이 부품들은 고객 셀프 수리가 불가능하도록 설계되었습니다. HP는 고객 보증을 만족시키기 위해 공인 서비스 제공업체를 통해 부품을 교체하도록 하고 있습니다.

System components

HP continually improves and changes product parts. For complete and current supported parts information, see one of the following websites:

- HP PartSurfer website (<http://partsurfer.hp.com>)
- HP PartSurfer mobile site (<http://partsurfermobile.hp.com>)

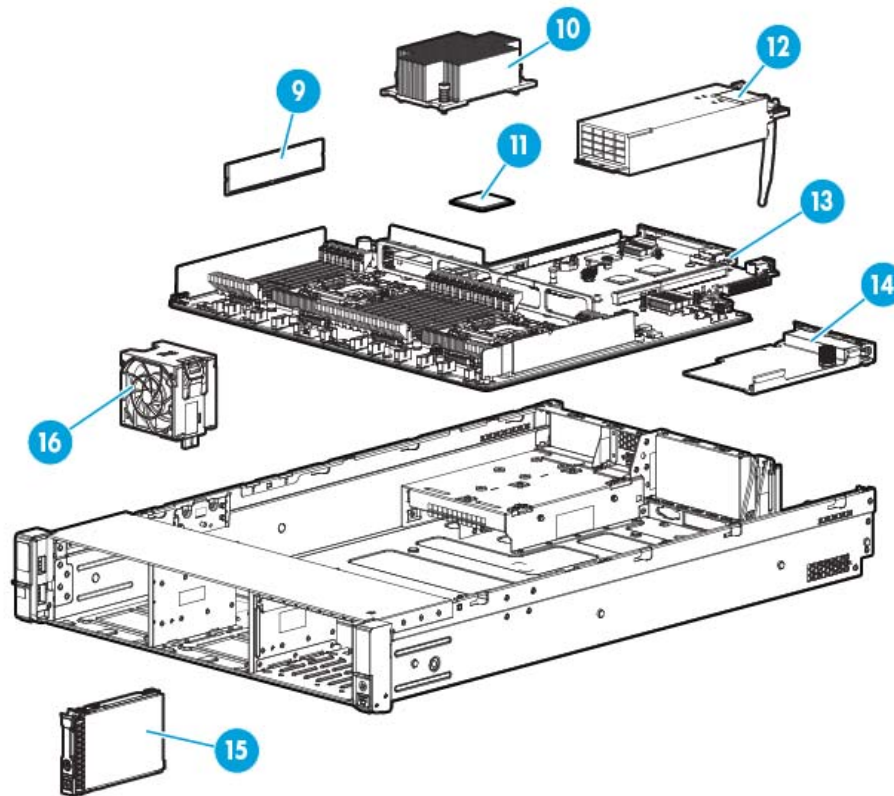

Item	Description	Spare part number	Customer self repair (on page 5)
	System components		
9	DIMMs	—	—
	a) 8-GB, 1Rx4, PC4-2133R	774170-001	Mandatory ¹
	b) 16-GB, 2Rx4, PC4-2133R*	774172-001	Mandatory ¹
	c) 32-GB, 32-GB, 4Rx4, PC4-2133L*	774174-001	Mandatory ¹
10	Heat sink, high performance* NOTE: Heatsink appearance may vary.	777291-001	Optional ²
11	Processors	—	—
	a) 1.80-GHz Intel Xeon E5-2603 v3 processor**	762441-001	Optional ²
	b) 2.00-GHz Intel Xeon E5-2609 v3 processor* **	762443-001	Optional ²
	c) 2.30-GHz Intel Xeon E5-2620 v3 processor* **	762445-001	Optional ²

Item	Description	Spare part number	Customer self repair (on page 5)
	d) 2.60-GHz Intel Xeon E5-2630 v3 processor* **	762446-001	Optional ²
	e) 2.20-GHz Intel Xeon E5-2640 v3 processor* **	762447-001	Optional ²
	f) 2.40-GHz Intel Xeon E5-2650 v3 processor* **	762448-001	Optional ²
	g) 2.60-GHz Intel Xeon E5-2660 v3 processor* **	762449-001	Optional ²
	h) 2.40-GHz Intel Xeon E5-2670 v3 processor* **	762450-001	Optional ²
	i) 2.60-GHz Intel Xeon E5-2680 v3 processor* **	762451-001	Optional ²
	j) 2.90-GHz Intel Xeon E5-2690 v3 processor* **	762452-001	Optional ²
	k) 2.00-GHz Intel Xeon E5-2683 v3 processor* **	762453-001	Optional ²
	l) 2.30-GHz Intel Xeon E5-2695 v3 processor* **	762454-001	Optional ²
	m) 2.70-GHz Intel Xeon E5-2697 v3 processor* **	765154-001	Optional ²
	n) 3.00-GHz Intel Xeon E5-2623 v3 processor* **	780762-001	Optional ²
	o) 3.50-GHz Intel Xeon E5-2637 v3 processor* **	762455-001	Optional ²
	p) 3.50-GHz Intel Xeon E5-2643 v3 processor* **	762456-001	Optional ²
	q) 3.30-GHz Intel Xeon E5-2667 v3 processor* **	762457-001	Optional ²
	r) 3.30-GHz Intel Xeon E5-2687W v3 processor* **	762458-001	Optional ²
	s) 1.50-GHz Intel Xeon E5-2630L v3 processor* **	762459-001	Optional ²
	t) 2.30-GHz Intel Xeon E5-2698 v3 processor* **	780760-002	Optional ²
	u) 2.30-GHz Intel Xeon E5-2699 v3 processor* **	780761-001	Optional ²
	v) 1.80-GHz Intel Xeon E5-2650L v3 processor* **	762461-001	Optional ²
12	Power supplies, hot-plug	—	—
	a) 800 W, Flex Slot Platinum*	754381-001	Mandatory ¹
	b) 1400 W, Flex Slot Platinum*	754383-001	Mandatory ¹
13	System I/O board assembly	775400-001	Optional ²
14	FlexibleLOM	—	—
	a) HP InfiniBand FDR 2-port, 5450-QSFP Adapter	705087-001	Mandatory ¹
	b) HP InfiniBand FDR 2-port, 545FLR-QSFP Adapter*	705088-001	Mandatory ¹
	Drives		
15	Hot-plug drives	—	—
	a) 146-GB, SAS, SFF, 15,000-rpm, 6G	653950-001	Mandatory ¹
	b) 300-GB, SAS, SFF, 10,000-rpm, 6G*	653955-001	Mandatory ¹
	c) 450-GB, SAS, SFF, 10,000-rpm, 6G*	653956-001	Mandatory ¹
	d) 500-GB, SAS, SFF, 7,200-rpm, 6G*	653953-001	Mandatory ¹
	e) 600-GB, SAS, SFF, 10,000-rpm, 6G*	653957-001	Mandatory ¹
	f) 900-GB, SAS, SFF, 10,000-rpm, 6G*	653971-001	Mandatory ¹
	g) 1-TB, SAS, SFF, 7,200-rpm, 6G*	653954-001	Mandatory ¹

Item	Description	Spare part number	Customer self repair (on page 5)
	h) 1-TB, SAS, LFF, 7,200-rpm, 6G*	653947-001	Mandatory ¹
	i) 1.2-TB, SAS, SFF, 10,000-rpm, 6G*	718292-001	Mandatory ¹
	j) 2 -TB, SAS, SFF, 7,200-rpm, 6G*	653948-001	Mandatory ¹
	k) 3 -TB, SAS, LFF, 7,200-rpm, 6G*	653959-001	Mandatory ¹
	l) 6-TB, SAS, LFF, 7,200-rpm, 6G*	761497-001	Mandatory ¹
	m) 500-GB, SATA, LFF, 7,200-rpm, 6G*	658103-001	Mandatory ¹
	n) 1-TB, SATA, SFF, 7,200-rpm, 6G*	656108-001	Mandatory ¹
	o) 1-TB, SATA, LFF, 7,200-rpm, 6G*	657739-001	Mandatory ¹
	p) 2-TB, SATA, LFF, 7,200-rpm, 6G*	658102-001	Mandatory ¹
	q) 3-TB, SATA, LFF, 7,200-rpm, 6G*	628182-001	Mandatory ¹
	r) 4-TB, SATA, LFF, 7,200-rpm, 6G*	693720-001	Mandatory ¹
	s) 6-TB, SATA, LFF, 7,200-rpm, 6G*	761496-001	Mandatory ¹
	Solid state drives	—	—
	a) 100-GB, SAS, ME, SFF, 6G*	692164-001	Mandatory ¹
	b) 200-GB, SAS, ME, SFF, 6G*	692165-001	Mandatory ¹
	c) 200-GB, SAS, ME, SFF, 12G*	741224-001	Mandatory ¹
	d) 200-GB, SAS, HE, SFF, 12G*	741230-001	Mandatory ¹
	e) 400-GB, SAS, ME, SFF, 12G*	741226-001	Mandatory ¹
	f) 400-GB, SAS, HE, SFF, 12G*	741232-001	Mandatory ¹
	g) 800-GB, SAS, VE, SFF, 12G*	762749-001	Mandatory ¹
	h) 800-GB, SAS, ME, SFF, 12G*	741228-001	Mandatory ¹
	i) 800-GB, SAS, HE, SFF, 12G*	741234-001	Mandatory ¹
	j) 800-GB, SAS, VE, LFF, 12G*	762750-001	Mandatory ¹
	k) 800-GB, SAS, ME, LFF, 12G*	692163-001	Mandatory ¹
	l) 1.6-TB, SAS, VE, SFF, 12G*	762751-001	Mandatory ¹
	m) 1.6-TB, SAS, VE, LFF, 12G*	762752-001	Mandatory ¹
	n) 80-GB, SATA, VE, SFF, 6G*	734562-001	Mandatory ¹
	o) 80-GB, SATA, VE, LFF, 6G*	734563-001	Mandatory ¹
	p) 100-GB, SATA, ME, LFF, 6G*	692160-001	Mandatory ¹
	q) 120-GB, SATA, VE, SFF, 6G*	718136-001	Mandatory ¹
	r) 120-GB, SATA, VE, LFF, 6G*	718300-001	Mandatory ¹
	s) 200-GB, SATA, ME, LFF, 6G*	692161-001	Mandatory ¹
	t) 240-GB, SATA, VE, SFF, 6G*	718137-001	Mandatory ¹
	u) 240-GB, SATA, VE, LFF, 6G*	718294-001	Mandatory ¹
	v) 400-GB, SATA, ME, LFF, 6G*	692162-001	Mandatory ¹

Item	Description	Spare part number	Customer self repair (on page 5)
	w) 480-GB, SATA, VE, SFF, 6G*	718138-001	Mandatory ¹
	x) 480-GB, SATA, VE, LFF, 6G*	718296-001	Mandatory ¹
	y) 800-GB, SATA, VE, SFF, 6G*	718139-001	Mandatory ¹
	z) 800-GB, SATA, VE, LFF, 6G*	718298-001	Mandatory ¹
	aa) 300-GB, SATA, VE, SFF, 6G*	739954-001	Mandatory ¹
	bb) 300-GB, SATA, VE, LFF, 6G*	739955-001	Mandatory ¹
	cc) 400-GB, SATA, ME, SFF, 6G*	692166-001	Mandatory ¹
	dd) 600-GB, SATA, VE, SFF, 6G*	739959-001	Mandatory ¹
	ee) 600-GB, SATA, VE, LFF, 6G*	739960-001	Mandatory ¹
	ff) 800-GB, SATA, ME, SFF, 6G*	692167-001	Mandatory ¹
16	Hot-plug fan, high performance*	777286-001	Mandatory ¹
17	Standard cabled power switch module*	777289-001	Mandatory ¹
	Other boards		
18	8-SFF backplane board*	777279-001	Optional ²
19	HP Smart Array P440ar Controller*	749796-001	Optional ²
20	HP H240ar HBA*	749997-001	Optional ²
21	HP 12Gb DL380 Gen9 SAS Expander Card	761879-001	Optional ²
22	HP NVIDIA Quadro K2200 3GB GPU*	783874-001	Optional ²
23	HP NVIDIA Quadro K4200 4GB GPU*	783875-001	Optional ²
24	HP NVIDIA Quadro K6000 4GB GPU*	736859-001	Optional ²
25	HP NVIDIA GRID K1 Quad GPU*	788358-001	Optional ²
26	HP NVIDIA GRID K2 RAF PCIe GPU*	756822-001	Optional ²
	Miscellaneous		
27	SFF standard ear kit, Gen9, left and right*	777295-001	Optional ²
28	0.5 thermal grease*	777297-001	Optional ²
29	1.0 thermal grease*	777298-001	Optional ²
30	HP Smart Storage Battery*	750450-001	Mandatory ¹
	Cables		
31	8 SFF mini-SAS cable*	784621-001	Mandatory ¹
32	8 SFF/12 LFF/4 LFF/24 SFF power cable*	784622-001	Mandatory ¹
33	DVD SATA cable*	784623-001	Mandatory ¹
34	2 SFF/26 SFF/4 LFF power cable*	784624-001	Mandatory ¹
35	2 SFF mini-SAS cable*	784625-001	Mandatory ¹
36	3 LFF/2 SFF mini-SAS cable*	784626-001	Mandatory ¹
37	2 SFF/8 SFF SAS cable (to H240)*	784629-001	Mandatory ¹

*Not shown

**All processors in this HP server must have the same cache size, speed, number of cores, and rated maximum power consumption.

¹Mandatory—Parts for which customer self repair is mandatory. If you request HP to replace these parts, you will be charged for the travel and labor costs of this service.

²Optional—Parts for which customer self repair is optional. These parts are also designed for customer self repair. If, however, you require that HP replace them for you, there may or may not be additional charges, depending on the type of warranty service designated for your product.

³No—Some HP parts are not designed for customer self repair. In order to satisfy the customer warranty, HP requires that an authorized service provider replace the part. These parts are identified as "No" in the Illustrated Parts Catalog.

¹Mandatory: Obligatoire—Pièces pour lesquelles la réparation par le client est obligatoire. Si vous demandez à HP de remplacer ces pièces, les coûts de déplacement et main d'œuvre du service vous seront facturés.

²Optional: Facultatif—Pièces pour lesquelles la réparation par le client est facultative. Ces pièces sont également conçues pour permettre au client d'effectuer lui-même la réparation. Toutefois, si vous demandez à HP de remplacer ces pièces, l'intervention peut ou non vous être facturée, selon le type de garantie applicable à votre produit.

³No: Non—Certaines pièces HP ne sont pas conçues pour permettre au client d'effectuer lui-même la réparation. Pour que la garantie puisse s'appliquer, HP exige que le remplacement de la pièce soit effectué par un Mainteneur Agréé. Ces pièces sont identifiées par la mention "Non" dans le Catalogue illustré.

¹Mandatory: Obbligatorie—Parti che devono essere necessariamente riparate dal cliente. Se il cliente ne affida la riparazione ad HP, deve sostenere le spese di spedizione e di manodopera per il servizio.

²Optional: Opzionali—Parti la cui riparazione da parte del cliente è facoltativa. Si tratta comunque di componenti progettati per questo scopo. Se tuttavia il cliente ne richiede la sostituzione ad HP, potrebbe dover sostenere spese aggiuntive a seconda del tipo di garanzia previsto per il prodotto.

³No: Non CSR—Alcuni componenti HP non sono progettati per la riparazione da parte del cliente. Per rispettare la garanzia, HP richiede che queste parti siano sostituite da un centro di assistenza autorizzato. Tali parti sono identificate da un "No" nel Catalogo illustrato dei componenti.

¹Mandatory: Zwingend—Teile, die im Rahmen des Customer Self Repair Programms ersetzt werden müssen. Wenn Sie diese Teile von HP ersetzen lassen, werden Ihnen die Versand- und Arbeitskosten für diesen Service berechnet.

²Optional: Optional—Teile, für die das Customer Self Repair-Verfahren optional ist. Diese Teile sind auch für Customer Self Repair ausgelegt. Wenn Sie jedoch den Austausch dieser Teile von HP vornehmen lassen möchten, können bei diesem Service je nach den für Ihr Produkt vorgesehenen Garantiebedingungen zusätzliche Kosten anfallen.

³No: Kein—Einige Teile sind nicht für Customer Self Repair ausgelegt. Um den Garantieanspruch des Kunden zu erfüllen, muss das Teil von einem HP Servicepartner ersetzt werden. Im illustrierten Teilekatalog sind diese Teile mit „No“ bzw. „Nein“ gekennzeichnet.

¹Mandatory: Obligatorio—componentes para los que la reparación por parte del usuario es obligatoria. Si solicita a HP que realice la sustitución de estos componentes, tendrá que hacerse cargo de los gastos de desplazamiento y de mano de obra de dicho servicio.

²Optional: Opcional— componentes para los que la reparación por parte del usuario es opcional. Estos componentes también están diseñados para que puedan ser reparados por el usuario. Sin embargo, si precisa que HP realice su sustitución, puede o no conllevar costes adicionales, dependiendo del tipo de servicio de garantía correspondiente al producto.

³No: No—Algunos componentes no están diseñados para que puedan ser reparados por el usuario. Para que el usuario haga valer su garantía, HP pone como condición que un proveedor de servicios autorizado realice la sustitución de estos componentes. Dichos componentes se identifican con la palabra "No" en el catálogo ilustrado de componentes.

¹Mandatory: Verplicht—Onderdelen waarvoor Customer Self Repair verplicht is. Als u HP verzoekt deze onderdelen te vervangen, komen de reiskosten en het arbeidsloon voor uw rekening.

²Optional: Optioneel—Onderdelen waarvoor reparatie door de klant optioneel is. Ook deze onderdelen zijn ontworpen voor reparatie door de klant. Als u echter HP verzoekt deze onderdelen voor u te vervangen, kunnen daarvoor extra kosten in rekening worden gebracht, afhankelijk van het type garantieservice voor het product.

³No: Nee—Sommige HP onderdelen zijn niet ontwikkeld voor reparatie door de klant. In verband met de garantievooraarden moet het onderdeel door een geautoriseerde Service Partner worden vervangen. Deze onderdelen worden in de geïllustreerde onderdelencatalogus aangemerkt met "Nee".

¹Mandatory: Obrigatória—Peças cujo reparo feito pelo cliente é obrigatório. Se desejar que a HP substitua essas peças, serão cobradas as despesas de transporte e mão-de-obra do serviço.

²Optional: Opcional—Peças cujo reparo feito pelo cliente é opcional. Essas peças também são projetadas para o reparo feito pelo cliente. No entanto, se desejar que a HP as substitua, pode haver ou não a cobrança de taxa adicional, dependendo do tipo de serviço de garantia destinado ao produto.

³No: Nenhuma—Algumas peças da HP não são projetadas para o reparo feito pelo cliente. A fim de cumprir a garantia do cliente, a HP exige que um técnico autorizado substitua a peça. Essas peças estão identificadas com a marca “No” (Não), no catálogo de peças ilustrado.

¹Mandatory: 必須・顧客自己修理が必須の部品。当該部品について、もしもお客様がHPに交換作業を依頼される場合には、その修理サービスに関する交通費および人件費がお客様に請求されます。

²Optional: 任意・顧客自己修理が任意である部品。この部品も顧客自己修理用です。当該部品について、もしもお客様がHPに交換作業を依頼される場合には、お買い上げの製品に適用される保証サービス内容の範囲内においては、費用を負担していただくことなく保証サービスを受けることができます。

³No: 除外・HP製品の一部の部品は、顧客自己修理用ではありません。製品の保証を継続するためには、HPまたはHP正規保守代理店による交換作業が必須となります。部品カタログには、当該部品が顧客自己修理除外品である旨が記載されています。

¹Mandatory: 强制性的 — 要求客户必须自行维修的部件。如果您请求 HP 更换这些部件，则必须为该服务支付差旅费和人工费用。

²Optional: 可选的 — 客户可以选择是否自行维修的部件。这些部件也是为客户自行维修设计的。不过，如果您要求 HP 为您更换这些部件，则根据为您的产品指定的保修服务类型，HP 可能收取或不再收取任何附加费用。

³No: 否 — 某些 HP 部件的设计并未考虑客户自行维修。为了满足客户保修的需要，HP 要求授权服务提供商更换相关部件。这些部件在部件图解目录中标记为“否”。

¹Mandatory: 強制的 — 客戶自行維修所使用的零件是強制性的。如果您要求 HP 更換這些零件，HP 將會向您收取此服務所需的外出費用與勞動成本。

²Optional: 選購的 — 客戶自行維修所使用的零件是選購的。這些零件也設計用於客戶自行維修之用。不過，如果您要求 HP 為您更換，則可能需要也可能不需要負擔額外的費用，端視針對此產品指定的保固服務類型而定。

³No: 否 — 某些 HP 零件沒有消費者可自行維修的設計。為符合客戶保固，HP 需要授權的服務供應商更換零件。這些零件在圖示的零件目錄中，被標示為「否」。

¹ Mandatory: 필수 — 고객 셀프 수리가 의무 사항인 필수 부품. 사용자가 HP에 이 부품의 교체를 요청할 경우 이 서비스에 대한 출장비 및 작업비가 청구됩니다.

² Optional: 옵션 — 고객 셀프 수리가 선택 사항인 부품. 이 부품들도 고객 셀프 수리가 가능하도록 설계되었습니다. 하지만 사용자가 HP에 이 부품의 교체를 요청할 경우 사용자가 구입한 제품에 해당하는 보증 서비스 유형에 따라 추가 비용 없이 교체가 가능할 수 있습니다.

³ No: No — 고객 셀프 수리가 불가능하도록 설계된 HP 부품. 이 부품들은 고객 셀프 수리가 불가능하도록 설계되었습니다. HP는 고객 보증을 만족시키기 위해 공인 서비스 제공업체를 통해 부품을 교체하도록 하고 있습니다.

Removal and replacement procedures

Required tools

You need the following items for some procedures:

- T-10/T-15 Torx screwdriver
- HP Insight Diagnostics software ("HP Insight Diagnostics" on page 73)

Preparation procedures

To access some components and perform certain service procedures, you must perform one or more of the following procedures:

- Extend the server from the rack (on page 26).
If you are performing service procedures in an HP, Compaq branded, telco, or third-party rack cabinet, you can use the locking feature of the rack rails to support the server and gain access to internal components.
For more information about telco rack solutions, refer to the RackSolutions.com website (<http://www.racksolutions.com/hp>).
- Power down the server (on page 25).
If you must remove a server from a rack or a non-hot-plug component from a server, power down the server.
- Remove the server from the rack (on page 26).
If the rack environment, cabling configuration, or the server location in the rack creates awkward conditions, remove the server from the rack.
- Access the product rear panel (on page 27).
- Access the Systems Insight Display ("Access the optional HP Systems Insight Display" on page 27).
- Release the full-length expansion board retainer (on page 28).

Power down the server

Before powering down the server for any upgrade or maintenance procedures, perform a backup of critical server data and programs.



IMPORTANT: When the server is in standby mode, auxiliary power is still being provided to the system.

To power down the server, use one of the following methods:

- Press and release the Power On/Standby button.
This method initiates a controlled shutdown of applications and the OS before the server enters standby mode.

- Press and hold the Power On/Standby button for more than 4 seconds to force the server to enter standby mode.
This method forces the server to enter standby mode without properly exiting applications and the OS. If an application stops responding, you can use this method to force a shutdown.
- Use a virtual power button selection through HP iLO.
This method initiates a controlled remote shutdown of applications and the OS before the server enters standby mode.

Before proceeding, verify the server is in standby mode by observing that the system power LED is amber.

Extend the server from the rack

⚠ WARNING: To reduce the risk of personal injury or equipment damage, be sure that the rack is adequately stabilized before extending a component from the rack.

1. Pull down the quick release levers on each side of the server.
2. Extend the server from the rack.

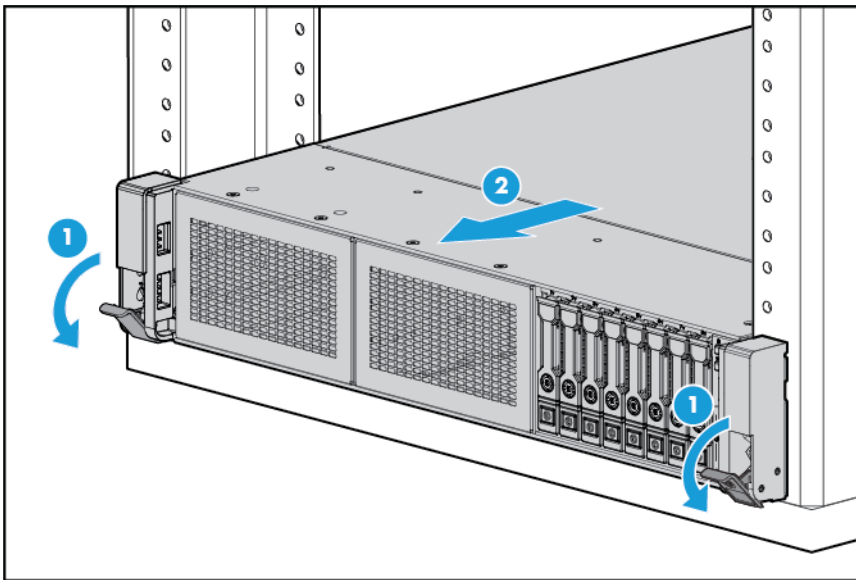

3. After performing the installation or maintenance procedure, slide the server back into the rack, and then press the server firmly into the rack to secure it in place.

⚠ WARNING: To reduce the risk of personal injury, be careful when pressing the server rail-release latches and sliding the server into the rack. The sliding rails could pinch your fingers.

Remove the server from the rack

To remove the server from an HP, Compaq branded, telco, or third-party rack:

1. Power down the server (on page 25).
2. Extend the server from the rack (on page 26).
3. Disconnect the cabling and remove the server from the rack. For more information, refer to the documentation that ships with the rack mounting option.

4. Place the server on a sturdy, level surface.

Access the product rear panel

Opening the cable management arm

To access the server rear panel:

1. Release the cable management arm.

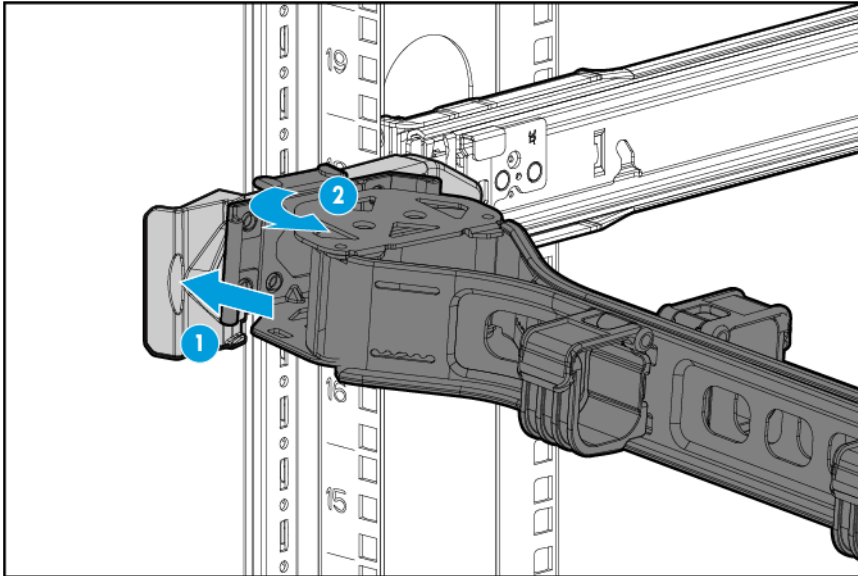

2. Open the cable management arm. The cable management arm can be right-mounted or left-mounted.

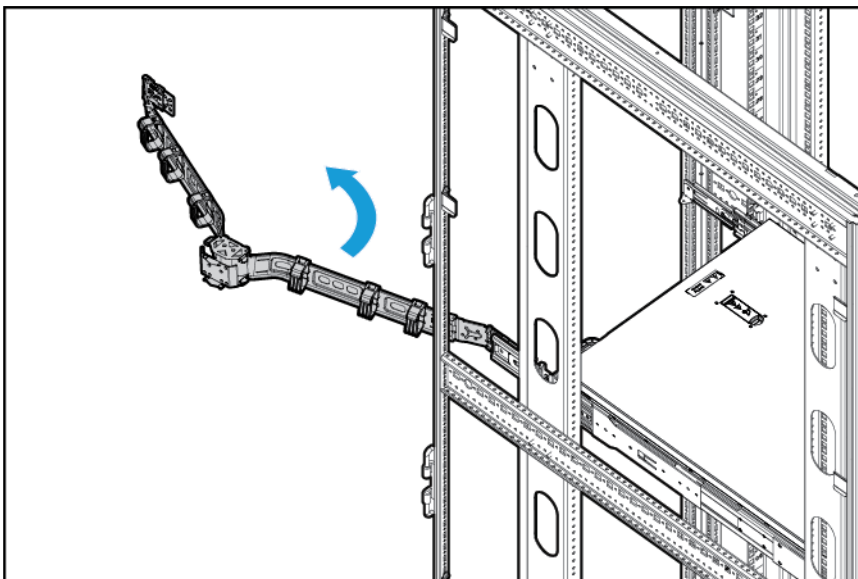

Access the optional HP Systems Insight Display

To access a pop-out HP Systems Insight Display on models with this option installed:

1. Press and release the panel.
2. After the display fully ejects, rotate the display to view the LEDs.

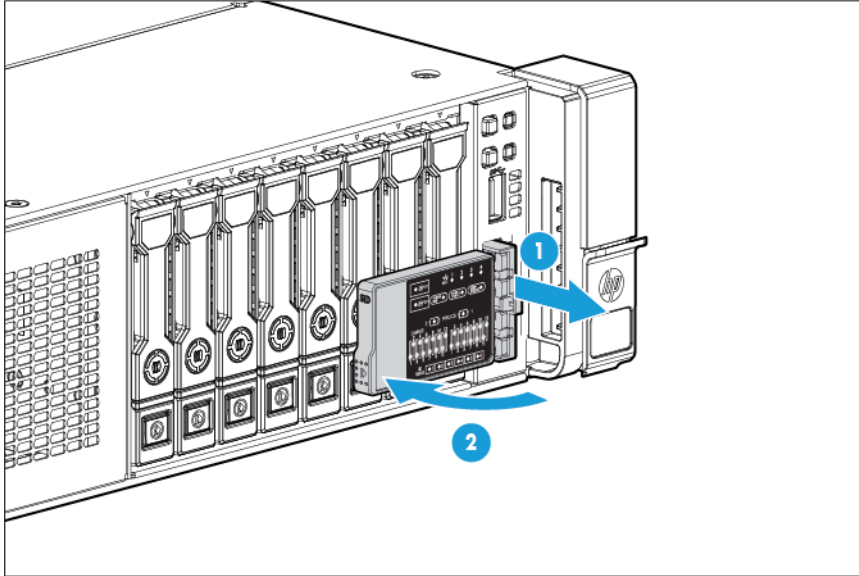

Release the full-length expansion board retainer

To remove the component:

1. Power down the server (on page 25).
2. Remove all power:
 - a. Disconnect each power cord from the power source.
 - b. Disconnect each power cord from the server.
3. Do one of the following:
 - o Extend the server from the rack (on page 26).
 - o Remove the server from the rack (on page 26).
4. Remove the access panel ("Access panel" on page 30).

5. Release the full-length expansion board retainer.

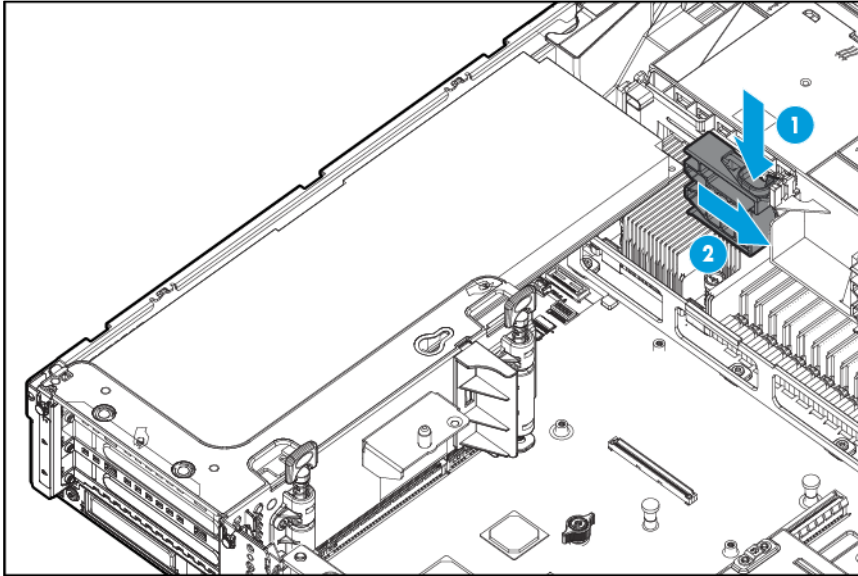

To replace the component, reverse the removal procedure.

Safety considerations

Before performing service procedures, review all the safety information.

Preventing electrostatic discharge

To prevent damaging the system, be aware of the precautions you need to follow when setting up the system or handling parts. A discharge of static electricity from a finger or other conductor may damage system boards or other static-sensitive devices. This type of damage may reduce the life expectancy of the device.

To prevent electrostatic damage:

- Avoid hand contact by transporting and storing products in static-safe containers.
- Keep electrostatic-sensitive parts in their containers until they arrive at static-free workstations.
- Place parts on a grounded surface before removing them from their containers.
- Avoid touching pins, leads, or circuitry.
- Always be properly grounded when touching a static-sensitive component or assembly.

Symbols on equipment

The following symbols may be placed on equipment to indicate the presence of potentially hazardous conditions.



This symbol indicates the presence of hazardous energy circuits or electric shock hazards. Refer all servicing to qualified personnel.

WARNING: To reduce the risk of injury from electric shock hazards, do not open this enclosure. Refer all maintenance, upgrades, and servicing to qualified personnel.



This symbol indicates the presence of electric shock hazards. The area contains no user or field serviceable parts. Do not open for any reason.

WARNING: To reduce the risk of injury from electric shock hazards, do not open this enclosure.



This symbol on an RJ-45 receptacle indicates a network interface connection.

WARNING: To reduce the risk of electric shock, fire, or damage to the equipment, do not plug telephone or telecommunications connectors into this receptacle.



This symbol indicates the presence of a hot surface or hot component. If this surface is contacted, the potential for injury exists.

WARNING: To reduce the risk of injury from a hot component, allow the surface to cool before touching.

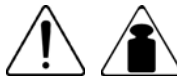

27.66 kg
61.0 lb

This symbol indicates that the component exceeds the recommended weight for one individual to handle safely.

WARNING: To reduce the risk of personal injury or damage to the equipment, observe local occupational health and safety requirements and guidelines for manual material handling.



These symbols, on power supplies or systems, indicate that the equipment is supplied by multiple sources of power.

WARNING: To reduce the risk of injury from electric shock, remove all power cords to completely disconnect power from the system.

Server warnings and cautions

Before installing a server, be sure that you understand the following warnings and cautions.



WARNING: To reduce the risk of electric shock or damage to the equipment:

- Do not disable the power cord grounding plug. The grounding plug is an important safety feature.
- Plug the power cord into a grounded (earthed) electrical outlet that is easily accessible at all times.
- Unplug the power cord from the power supply to disconnect power to the equipment.
- Do not route the power cord where it can be walked on or pinched by items placed against it. Pay particular attention to the plug, electrical outlet, and the point where the cord extends from the server.





WARNING: To reduce the risk of personal injury from hot surfaces, allow the drives and the internal system components to cool before touching them.



CAUTION: Do not operate the server for long periods with the access panel open or removed. Operating the server in this manner results in improper airflow and improper cooling that can lead to thermal damage.

Access panel

 **WARNING:** To reduce the risk of personal injury from hot surfaces, allow the drives and the internal system components to cool before touching them.

 **CAUTION:** Do not operate the server for long periods with the access panel open or removed. Operating the server in this manner results in improper airflow and improper cooling that can lead to thermal damage.

To remove the component:

1. Power down the server (on page [25](#)).
2. Extend the server from the rack (on page [26](#)).
Open or unlock the locking latch, slide the access panel to the rear of the chassis, and remove the access panel.

To replace the component:

1. Place the access panel on top of the server with the hood latch open. Allow the panel to extend past the rear of the server approximately 1.25 cm (0.5 in).
2. Push down on the hood latch. The access panel slides to a closed position.
3. Tighten the security screw on the hood latch.

Air baffle

 **CAUTION:** For proper cooling, do not operate the server without the access panel, baffles, expansion slot covers, or blanks installed. If the server supports hot-plug components, minimize the amount of time the access panel is open.

To remove the component:

1. Power down the server (on page [25](#)).
2. Remove all power:
 - a. Disconnect each power cord from the power source.
 - b. Disconnect each power cord from the server.
3. Do one of the following:
 - o Extend the server from the rack (on page [26](#)).
 - o Remove the server from the rack (on page [26](#)).
4. Remove the access panel ("[Access panel](#)" on page [30](#)).

5. Remove the air baffle.

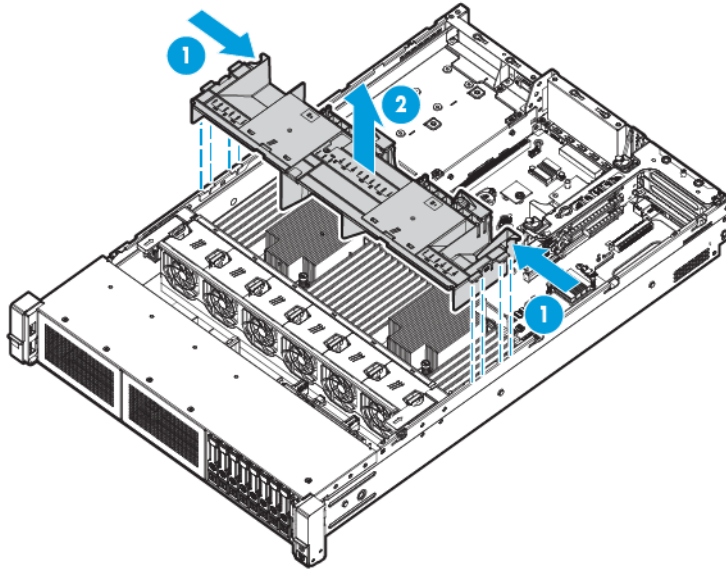

To replace the component, reverse the removal procedure.

PCIe riser blank

CAUTION: To prevent improper cooling and thermal damage, do not operate the server unless all PCI slots have either an expansion slot cover or an expansion board installed.

To remove the component:

1. Power down the server (on page 25).
2. Remove all power:
 - a. Disconnect each power cord from the power source.
 - b. Disconnect each power cord from the server.
3. Do one of the following:
 - o Extend the server from the rack (on page 26).
 - o Remove the server from the rack (on page 26).
4. Remove the access panel ("Access panel" on page 30).

5. Remove the PCIe riser blank.

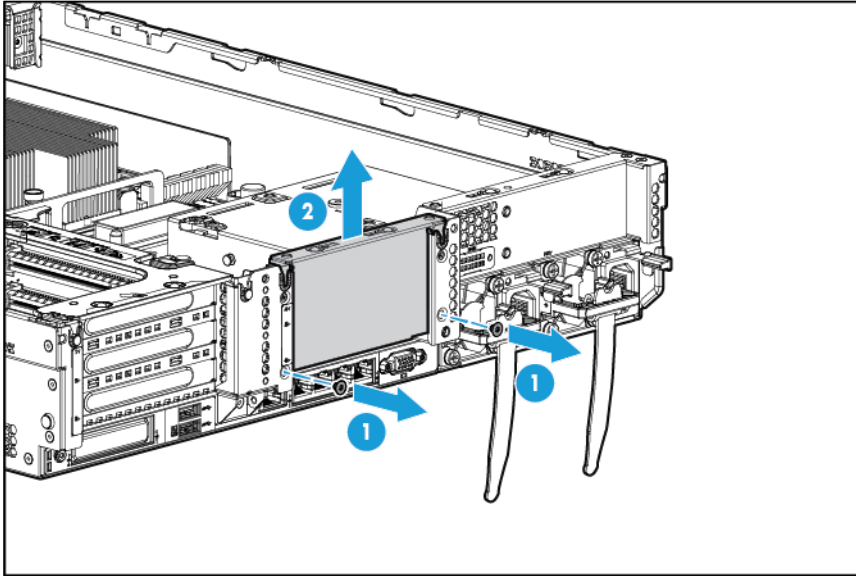

To replace the component, reverse the removal procedure.

Primary PCIe riser cage



WARNING: To reduce the risk of personal injury, electric shock, or damage to the equipment, remove the power cord to remove power from the server. The front panel Power On/Standby button does not completely shut off system power. Portions of the power supply and some internal circuitry remain active until AC power is removed.

To remove the component:

1. Power down the server (on page 25).
2. Remove all power:
 - a. Disconnect each power cord from the power source.
 - b. Disconnect each power cord from the server.
3. Disconnect any external cables that are connected to the expansion board.
4. Do one of the following:
 - o Extend the server from the rack (on page 26).
 - o Remove the server from the rack (on page 26).
5. Remove the access panel ("Access panel" on page 30).
6. Disconnect any internal cables that are connected to the expansion board.
7. If any full-length expansion boards are installed, release the full-length expansion board retainer (on page 28).

8. Remove the PCIe riser cage.

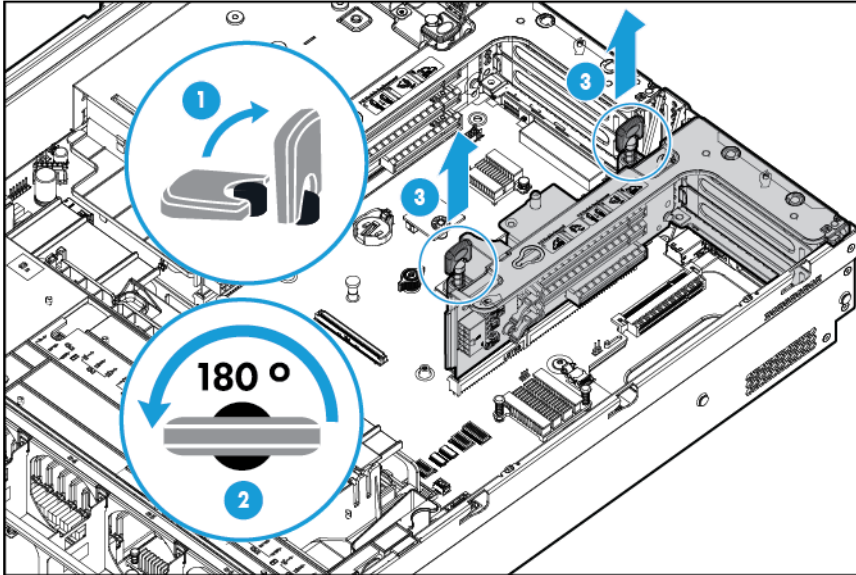

To replace the component, reverse the removal procedure.

Secondary PCIe riser cage



WARNING: To reduce the risk of personal injury, electric shock, or damage to the equipment, remove the power cord to remove power from the server. The front panel Power On/Standby button does not completely shut off system power. Portions of the power supply and some internal circuitry remain active until AC power is removed.

To remove the component:

1. Power down the server (on page 25).
2. Remove all power:
 - a. Disconnect each power cord from the power source.
 - b. Disconnect each power cord from the server.
3. Disconnect any external cables that are connected to the expansion board.
4. Do one of the following:
 - o Extend the server from the rack (on page 26).
 - o Remove the server from the rack (on page 26).
5. Remove the access panel ("Access panel" on page 30).
6. Disconnect any internal cables that are connected to the expansion board.
7. If any full-length expansion boards are installed, release the full-length expansion board retainer (on page 28).

8. Remove the secondary PCIe riser cage.

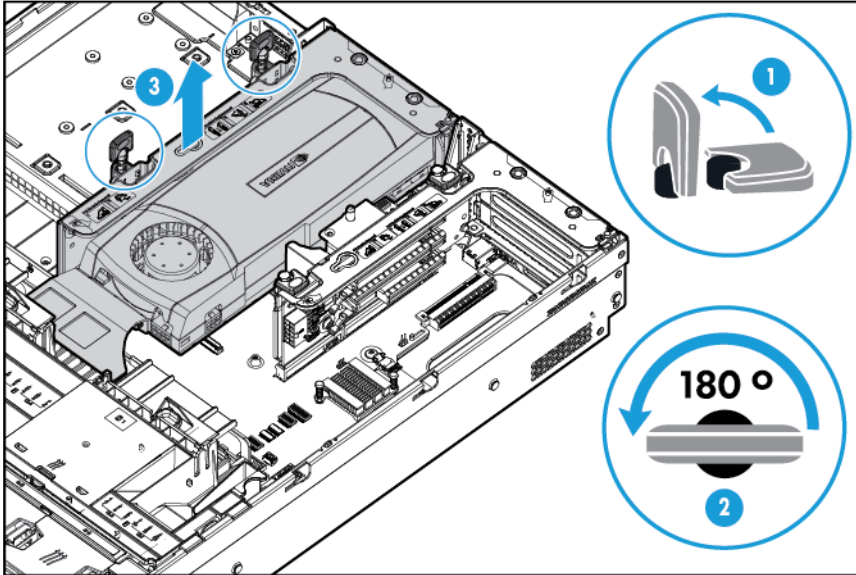

To replace the component, reverse the removal procedure.

PCIe riser board

To remove the component:

1. Power down the server (on page 25).
2. Remove all power:
 - a. Disconnect each power cord from the power source.
 - b. Disconnect each power cord from the server.
3. Do one of the following:
 - o Extend the server from the rack (on page 26).
 - o Remove the server from the rack (on page 26).
4. Remove the access panel ("Access panel" on page 30).
5. If any full-length expansion boards are installed, release the full-length expansion board retainer (on page 28).
6. Remove the PCIe riser cage:
 - o Primary PCIe riser cage (on page 33)
 - o Secondary PCIe riser cage (on page 34)
7. Remove any expansion boards (on page 49) from the PCIe riser cage.

8. Remove the PCIe riser board.

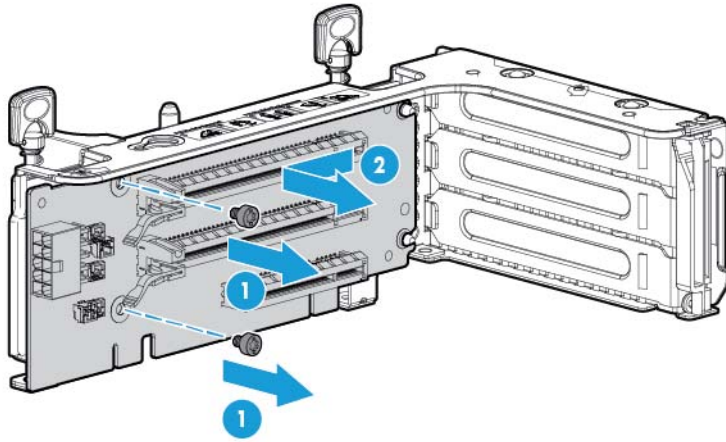

To replace the component, reverse the removal procedure.

Drive blank

- CAUTION:** To prevent improper cooling and thermal damage, do not operate the server unless all bays are populated with either a component or a blank.

To remove the component:

1. Remove the drive blank.

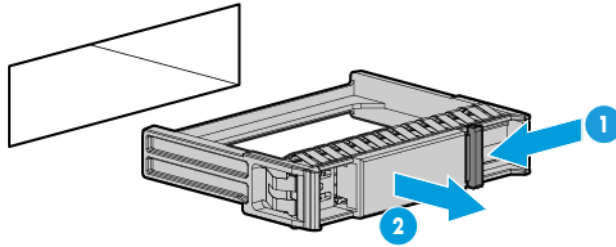

To replace the blank, slide the blank into the bay until it locks into place.

Hot-plug drive

- CAUTION:** To prevent improper cooling and thermal damage, do not operate the server unless all bays are populated with either a component or a blank.

To remove the component:

1. Back up all server data on the drive.
2. Determine the status of the drive from the drive LED definitions ("[Hot-plug drive LED definitions](#)" on page 90).

3. Remove the drive.

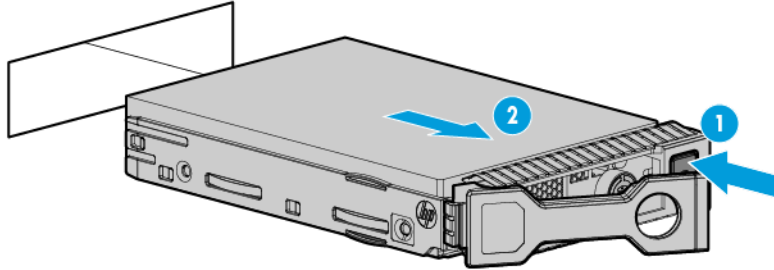

To replace the component, reverse the removal procedure.

Power supply blank

Remove the component as indicated.

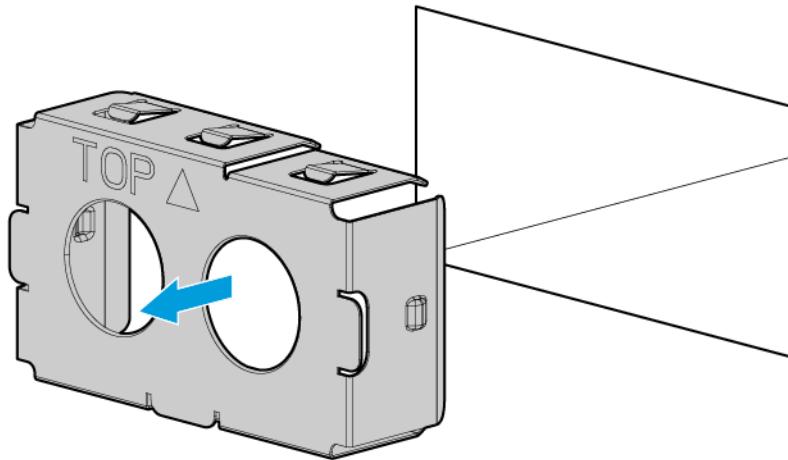

To replace the component, reverse the removal procedure.

AC power supply

⚠ CAUTION: To prevent improper cooling and thermal damage, do not operate the server unless all bays are populated with either a component or a blank.

To remove the component:

1. Power down the server (on page 25).
2. Remove all power:
 - a. Disconnect each power cord from the power source.
 - b. Disconnect each power cord from the server.
3. Access the product rear panel (on page 27).
4. Remove the power supply.



WARNING: To reduce the risk of personal injury from hot surfaces, allow the power supply or power supply blank to cool before touching it.

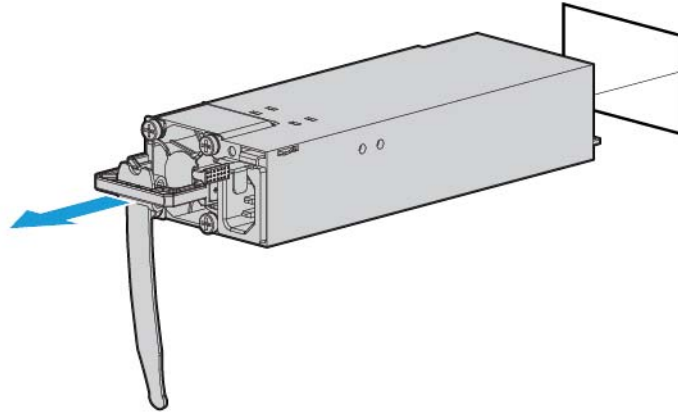

To replace the component, reverse the removal procedure.

Optical drive

To remove the component:

1. Power down the server (on page 25).
2. Remove all power:
 - a. Disconnect each power cord from the power source.
 - b. Disconnect each power cord from the server.
3. Do one of the following:
 - o Extend the server from the rack (on page 26).
 - o Remove the server from the rack (on page 26).
4. Remove the access panel ("Access panel" on page 30).
5. Remove the fan cage ("Fan cage" on page 41).

6. Disconnect the optical drive cable.

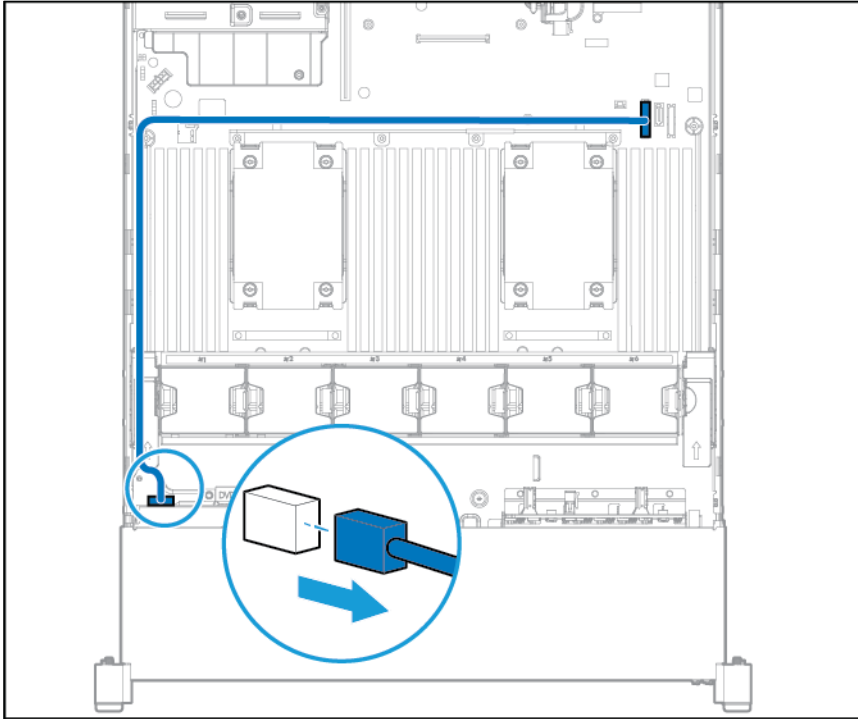

7. Remove the optical drive.

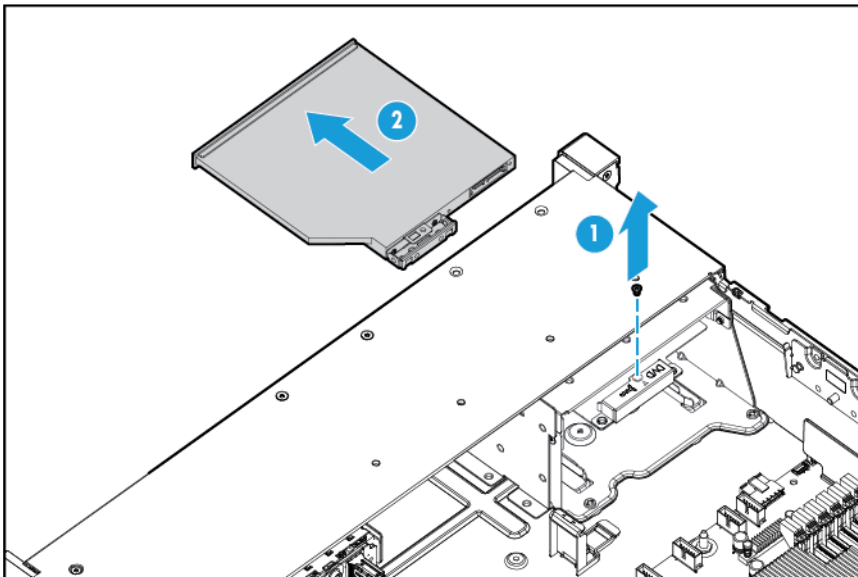

8. Remove the optical drive bracket, for use with the replacement optical drive.

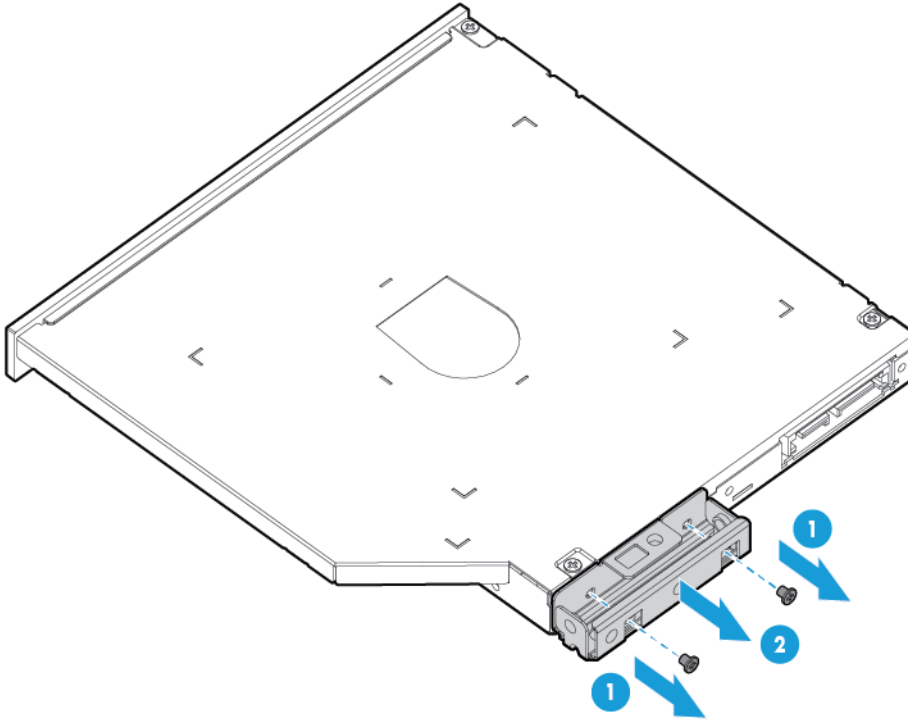

9. Before replacing the component, install the optical drive bracket, retained from the optical drive you are replacing.

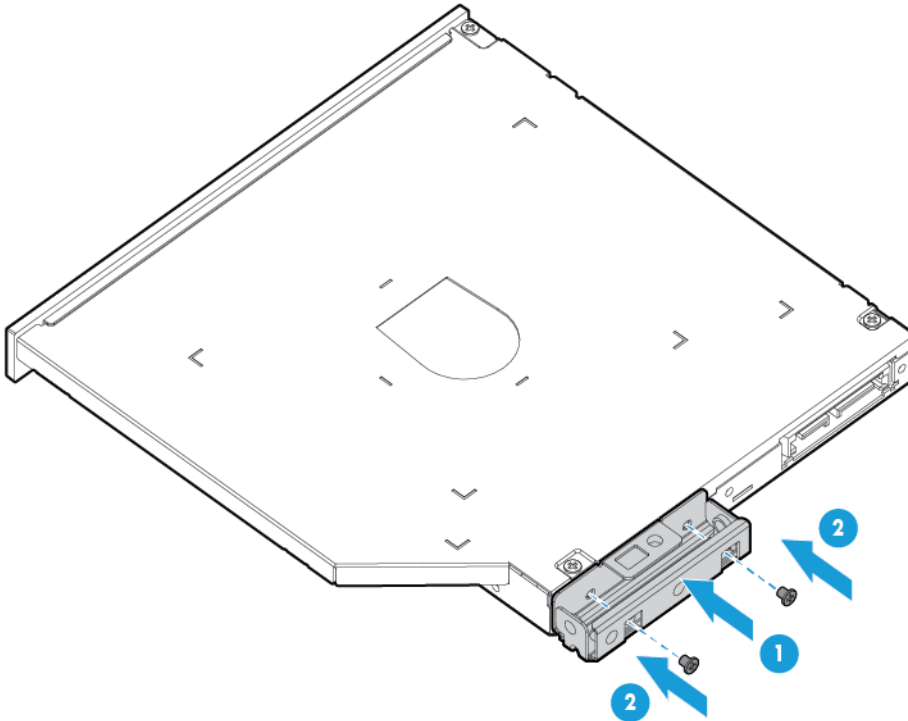

To replace the component, reverse the removal procedure.

Hot-plug fan

To remove the component:

1. Power down the server (on page 25).
2. Remove all power:
 - a. Disconnect each power cord from the power source.
 - b. Disconnect each power cord from the server.
3. Do one of the following:
 - o Extend the server from the rack (on page 26).
 - o Remove the server from the rack (on page 26).
4. Remove the access panel ("Access panel" on page 30).
5. Remove the fan.

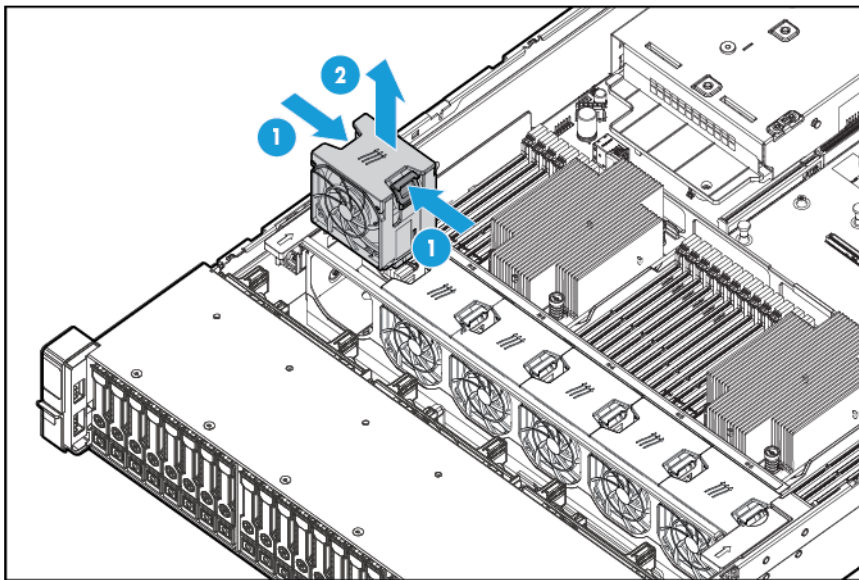

CAUTION: Do not operate the server for long periods with the access panel open or removed. Operating the server in this manner results in improper airflow and improper cooling that can lead to thermal damage.



IMPORTANT: For optimum cooling, install fans in all primary fan locations. For more information, refer to the fan locations table ("Hot-plug fans" on page 91).

To replace the component, reverse the removal procedure.

Fan cage

To remove the component:

1. Power down the server (on page 25).
2. Remove all power:
 - a. Disconnect each power cord from the power source.
 - b. Disconnect each power cord from the server.

3. Do one of the following:
 - Extend the server from the rack (on page 26).
 - Remove the server from the rack (on page 26).
4. Remove the access panel ("Access panel" on page 30).
5. Remove the fan cage.

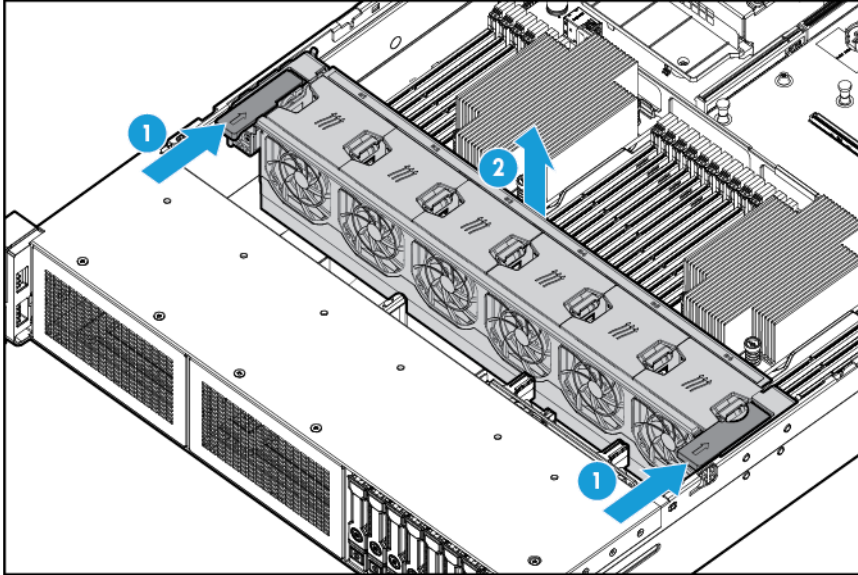

CAUTION: Do not operate the server for long periods with the access panel open or removed. Operating the server in this manner results in improper airflow and improper cooling that can lead to thermal damage.

IMPORTANT: For optimum cooling, install fans in all primary fan locations. For more information, refer to the fan locations table ("Hot-plug fans" on page 91).

FlexibleLOM

To remove the component:

1. Power down the server (on page 25).
2. Remove all power:
 - a. Disconnect each power cord from the power source.
 - b. Disconnect each power cord from the server.
3. Disconnect the LAN segment cables.
4. Do one of the following:
 - Extend the server from the rack (on page 26).
 - Remove the server from the rack (on page 26).

5. Remove the FlexibleLOM.

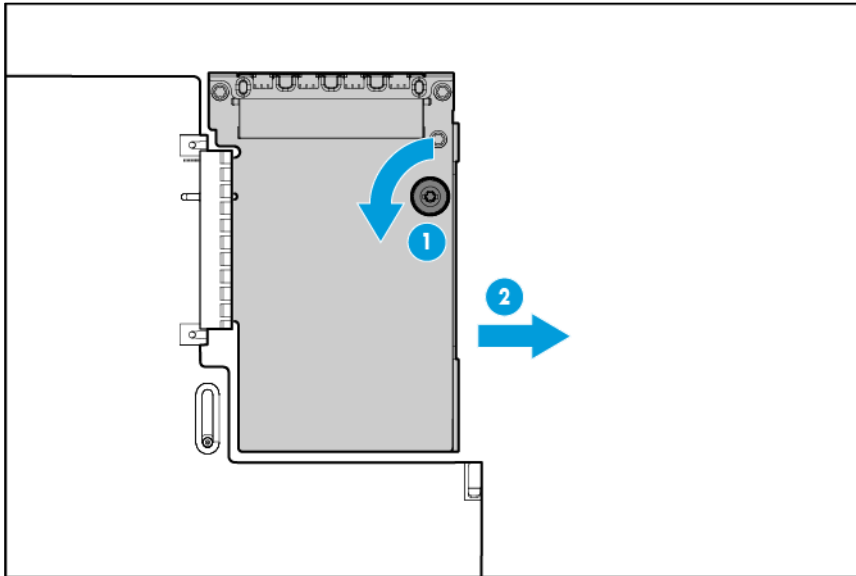

To replace the component, reverse the removal procedure.

8-SFF drive cage

To remove the component:

1. Power down the server (on page 25).
2. Remove all power:
 - a. Disconnect each power cord from the power source.
 - b. Disconnect each power cord from the server.
3. Do one of the following:
 - o Extend the server from the rack (on page 26).
 - o Remove the server from the rack (on page 26).
4. Remove the access panel ("Access panel" on page 30).
5. Remove all drives ("Hot-plug drive" on page 36).
6. Remove the fan cage ("Fan cage" on page 41).
7. Disconnect all cables from the drive backplane.

8. Remove the drive cage.

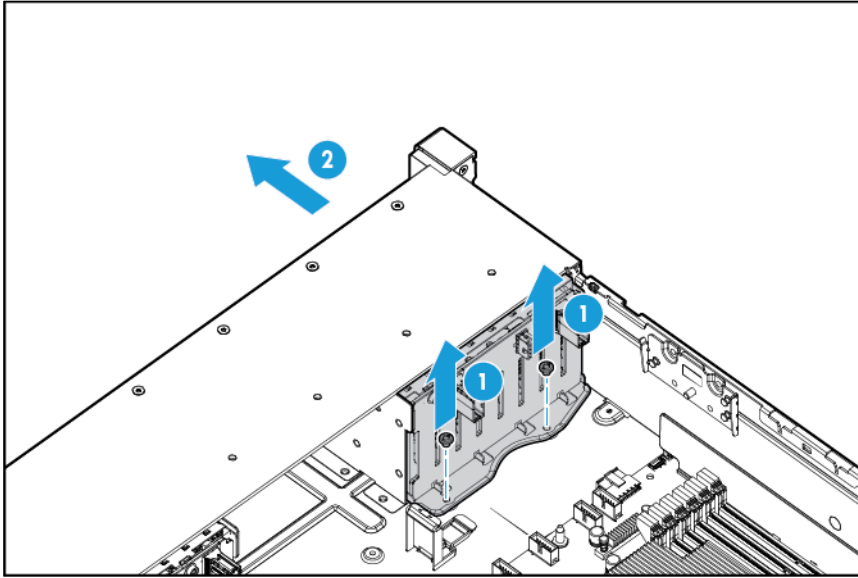

To replace the component, reverse the removal procedure.

2-SFF front drive cage

To remove the component:

1. Power down the server (on page 25).
2. Remove all power:
 - a. Disconnect each power cord from the power source.
 - b. Disconnect each power cord from the server.
3. Do one of the following:
 - o Extend the server from the rack (on page 26).
 - o Remove the server from the rack (on page 26).
4. Remove the access panel ("Access panel" on page 30).
5. Remove all drives ("Hot-plug drive" on page 36).
6. Disconnect all cables from the drive backplane.

7. Remove the drive cage.

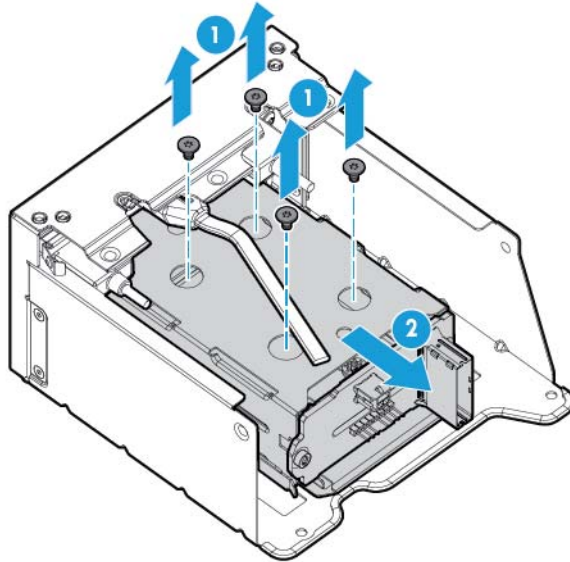

To replace the component, reverse the removal procedure.

Universal media bay

To remove the component:

1. Power down the server (on page 25).
2. Remove all power:
 - a. Disconnect each power cord from the power source.
 - b. Disconnect each power cord from the server.
3. Do one of the following:
 - o Extend the server from the rack (on page 26).
 - o Remove the server from the rack (on page 26).
4. Remove the access panel ("Access panel" on page 30).
5. Remove all hot-plug hard drives.
6. Remove the fan cage ("Fan cage" on page 41).
7. Disconnect all cables from the universal media bay.

8. Remove the universal media bay.

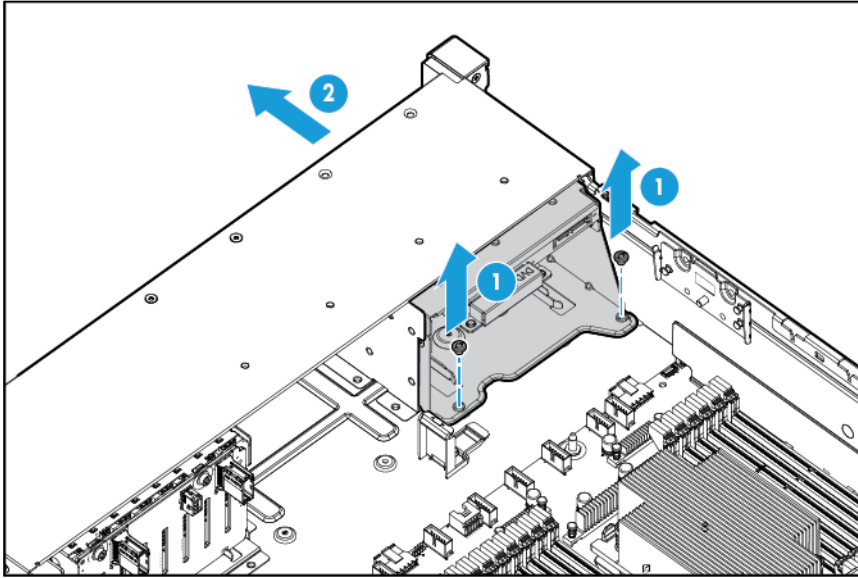

To replace the component, reverse the removal procedure.

8-SFF drive backplane

To remove the component:

1. Power down the server (on page 25).
2. Remove all power:
 - a. Disconnect each power cord from the power source.
 - b. Disconnect each power cord from the server.
3. Do one of the following:
 - o Extend the server from the rack (on page 26).
 - o Remove the server from the rack (on page 26).
4. Remove the access panel ("Access panel" on page 30).
5. Remove the fan cage ("Fan cage" on page 41).
6. Remove all drives ("Hot-plug drive" on page 36).

7. Remove the drive backplane.

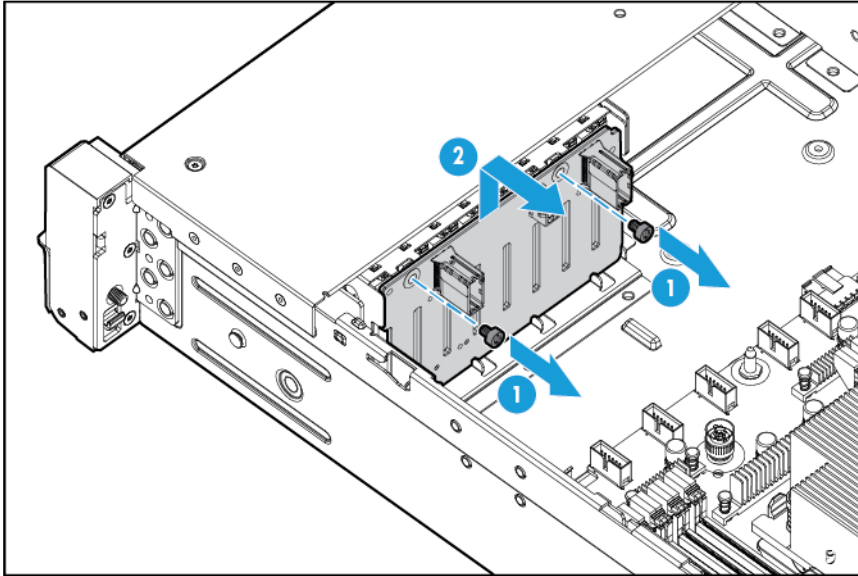

To replace the component, reverse the removal procedure.

Systems Insight Display

To remove the component:

1. Power down the server (on page 25).
2. Remove all power:
 - a. Disconnect each power cord from the power source.
 - b. Disconnect each power cord from the server.
3. Do one of the following:
 - o Extend the server from the rack (on page 26).
 - o Remove the server from the rack (on page 26).
4. Remove the access panel ("Access panel" on page 30).
5. Remove the air baffle ("Air baffle" on page 31).
6. Remove the fan cage ("Fan cage" on page 41).
7. Disconnect the Systems Insight Display cable and the USB cable from the system board, and then disconnect the USB cable from the front of the Systems Insight Display.

8. Remove the screw securing the Systems Insight Display, and then remove the Systems Insight Display.

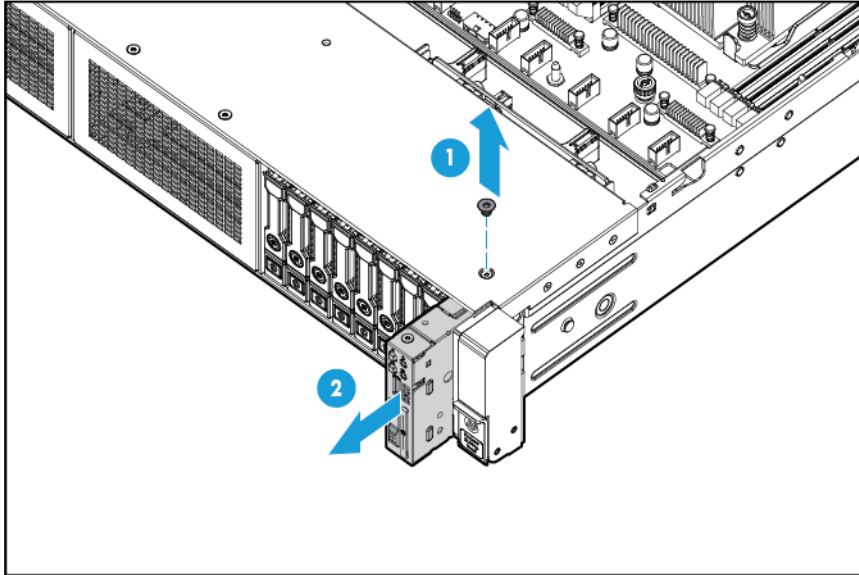

To replace the component, reverse the removal procedure.

Expansion slot blanks

-
- ⚠ WARNING:** To reduce the risk of personal injury, electric shock, or damage to the equipment, remove the power cord to remove power from the server. The front panel Power On/Standby button does not completely shut off system power. Portions of the power supply and some internal circuitry remain active until AC power is removed.
-
- ⚠ CAUTION:** For proper cooling, do not operate the server without the access panel, baffles, expansion slot covers, or blanks installed. If the server supports hot-plug components, minimize the amount of time the access panel is open.
-

To remove the component:

1. Power down the server (on page 25).
2. Remove all power:
 - a. Disconnect each power cord from the power source.
 - b. Disconnect each power cord from the server.
3. Do one of the following:
 - Extend the server from the rack (on page 26).
 - Remove the server from the rack (on page 26).
4. Remove the access panel ("Access panel" on page 30).
5. Remove the PCIe riser cage:
 - Primary PCIe riser cage (on page 33)
 - Secondary PCIe riser cage (on page 34)
6. Remove the expansion slot blank:

- Primary PCIe riser cage

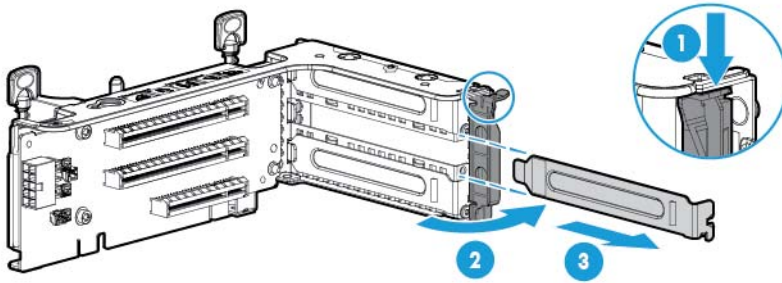

- Optional primary PCIe riser cage

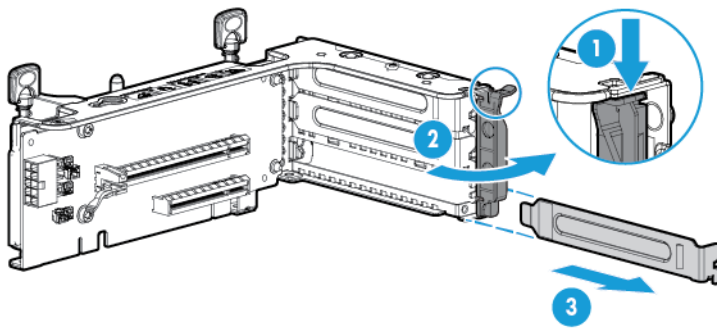

- Secondary PCIe riser cage

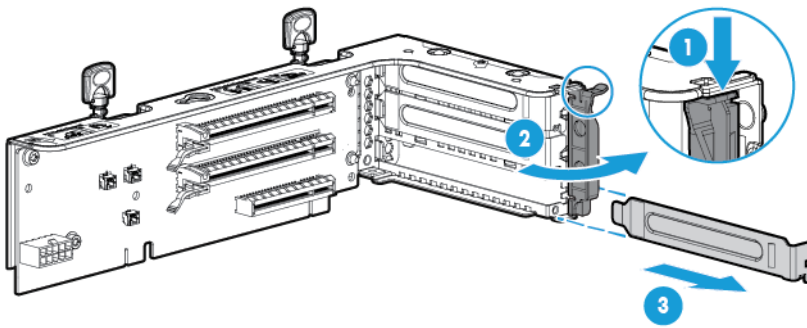

To replace the component, reverse the removal procedure.

Expansion boards

Full length expansion board

⚠ WARNING: To reduce the risk of personal injury, electric shock, or damage to the equipment, remove the power cord to remove power from the server. The front panel Power On/Standby button does not completely shut off system power. Portions of the power supply and some internal circuitry remain active until AC power is removed.

To remove the component:

1. Power down the server (on page 25).
2. Remove all power:
 - a. Disconnect each power cord from the power source.
 - b. Disconnect each power cord from the server.
3. Disconnect any external cables that are connected to the expansion board.
4. Do one of the following:
 - o Extend the server from the rack (on page 26).
 - o Remove the server from the rack (on page 26).
5. Remove the access panel ("Access panel" on page 30).
6. Disconnect any internal cables that are connected to the expansion board.
7. Release the full-length expansion board retainer (on page 28).
8. Remove the PCIe riser cage:
 - o Primary PCIe riser cage (on page 33)
 - o Secondary PCIe riser cage (on page 34)
9. Remove the expansion board.

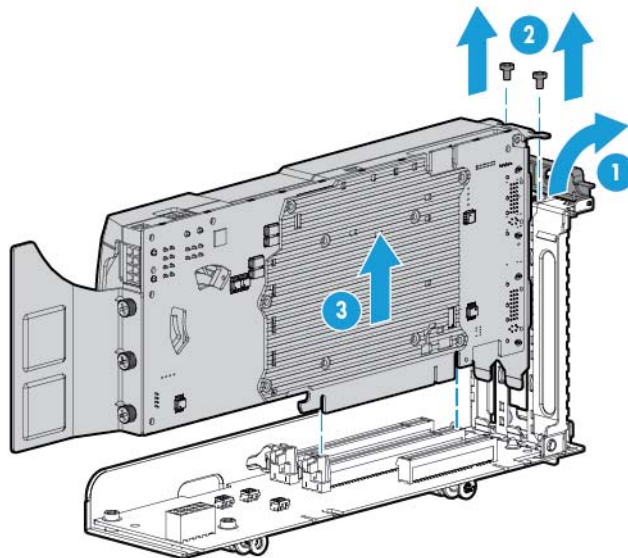

To replace the component, reverse the removal procedure.

Half-length expansion board

⚠ WARNING: To reduce the risk of personal injury, electric shock, or damage to the equipment, remove the power cord to remove power from the server. The front panel Power On/Standby button does not completely shut off system power. Portions of the power supply and some internal circuitry remain active until AC power is removed.

To remove the component:

1. Power down the server (on page 25).
2. Remove all power:
 - a. Disconnect each power cord from the power source.
 - b. Disconnect each power cord from the server.
3. Disconnect any external cables that are connected to the expansion board.
4. Do one of the following:
 - o Extend the server from the rack (on page 26).
 - o Remove the server from the rack (on page 26).
5. Remove the access panel ("Access panel" on page 30).
6. Disconnect any internal cables that are connected to the expansion board.
7. Remove the PCIe riser cage:
 - o Primary PCIe riser cage (on page 33)
 - o Secondary PCIe riser cage (on page 34)
8. Remove the expansion board.

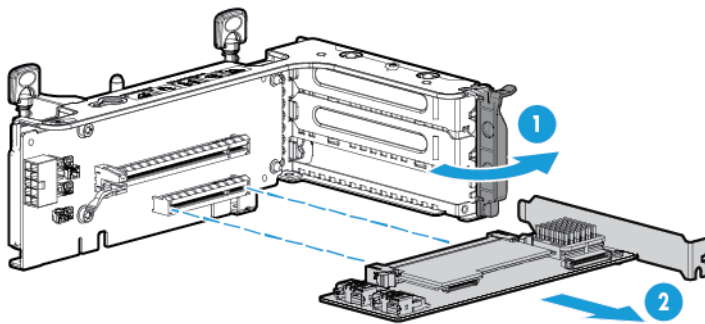

To replace the component, reverse the removal procedure.

Heatsink

⚠ WARNING: To reduce the risk of personal injury from hot surfaces, allow the drives and the internal system components to cool before touching them.

⚠ CAUTION: The heatsink thermal interface media is not reusable and must be replaced if the heatsink is removed from the processor after it has been installed.

⚠ CAUTION: To avoid thermal shutdown, all fans must be installed in a dual processor configuration.

NOTE: Heatsink appearance may vary.

To remove the component:

1. Power down the server (on page 25).
2. Remove all power:
 - a. Disconnect each power cord from the power source.
 - b. Disconnect each power cord from the server.
3. Do one of the following:
 - o Extend the server from the rack (on page 26).
 - o Remove the server from the rack (on page 26).
4. Remove the access panel ("Access panel" on page 30).
5. Remove the air baffle ("Air baffle" on page 31).
6. Remove the heatsink.

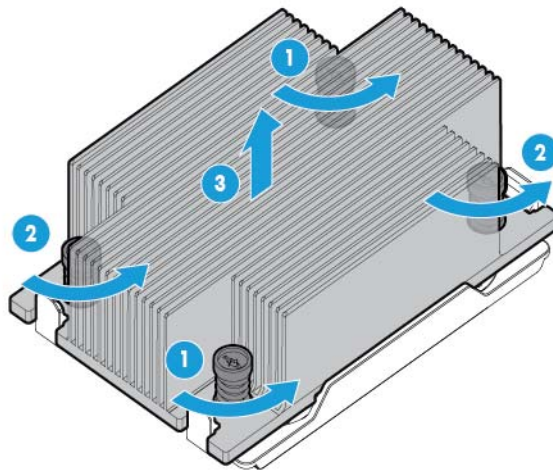

To replace the component:

1. Remove the thermal interface protective cover from the heatsink.

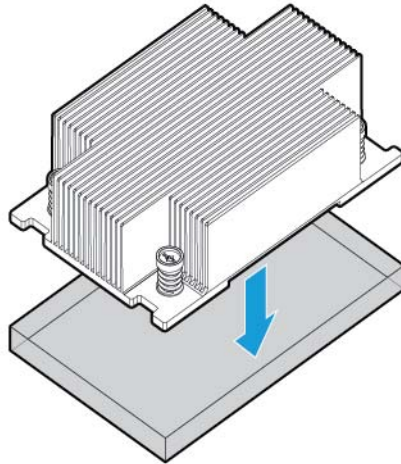

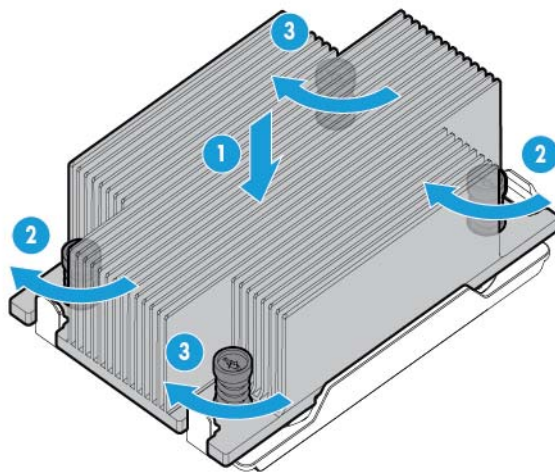

2. Install the heatsink.





3. Install the air baffle ("[Air baffle](#)" on page 31).
4. Install the access panel ("[Access panel](#)" on page 30).
5. Slide the server into the rack.
6. Connect each power cord to the server.
7. Connect each power cord to the power source.
8. Power up the server.

Processor

-
-  **WARNING:** To reduce the risk of personal injury from hot surfaces, allow the drives and the internal system components to cool before touching them.

 -  **CAUTION:** To prevent possible server malfunction, do not mix processors of different speeds or cache sizes. Refer to the label on the processor heatsink for a description of the processor.

 -  **CAUTION:** To prevent possible server overheating, always populate each processor socket with a processor socket cover and a heatsink blank or a processor and a heatsink.

 -  **IMPORTANT:** Processor socket 1 must always be populated. If processor socket 1 is empty, the server does not power up.
-

Depending on the memory configuration and processor model, the memory speed may run at 1600MHz, 1866MHz, or 2133MHz.

To remove the component:

1. Update the system ROM.
Locate and download the latest ROM version from the HP website (<http://www.hp.com/support>). Follow the instructions on the website to update the system ROM.
2. Power down the server (on page 25).
3. Remove the server from the rack (on page 26).
4. Remove the access panel ("Access panel" on page 30).
5. Remove the heatsink ("Heatsink" on page 51).
6. Open each of the processor locking levers in the order indicated, and then open the processor retaining bracket.

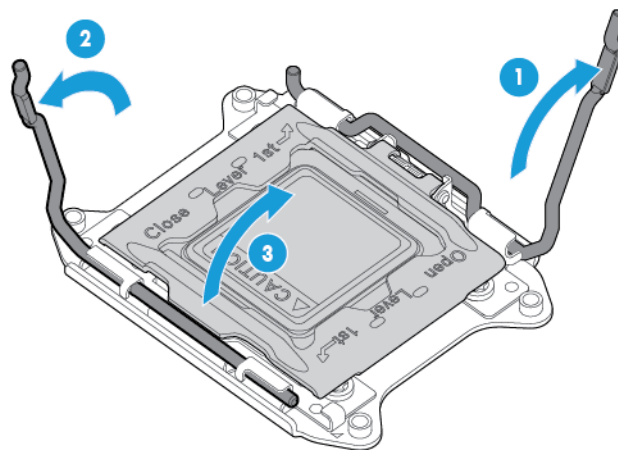

7. Remove the processor from the processor retaining bracket.

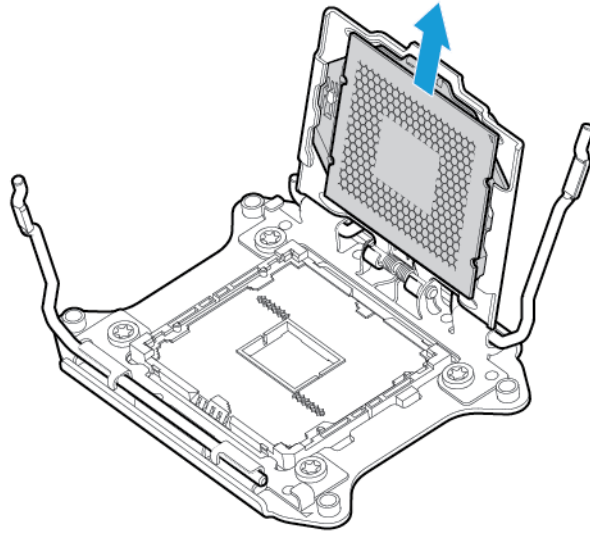

△ **CAUTION:** To avoid damage to the processor, do not touch the bottom of the processor, especially the contact area.

To replace the component:

△ **CAUTION:** To avoid damage to the system board, processor socket, and screws, do not overtighten the heatsink screws.

1. Install the processor. Verify that the processor is fully seated in the processor retaining bracket by visually inspecting the processor installation guides on either side of the processor. **THE PINS ON THE SYSTEM BOARD ARE VERY FRAGILE AND EASILY DAMAGED.**

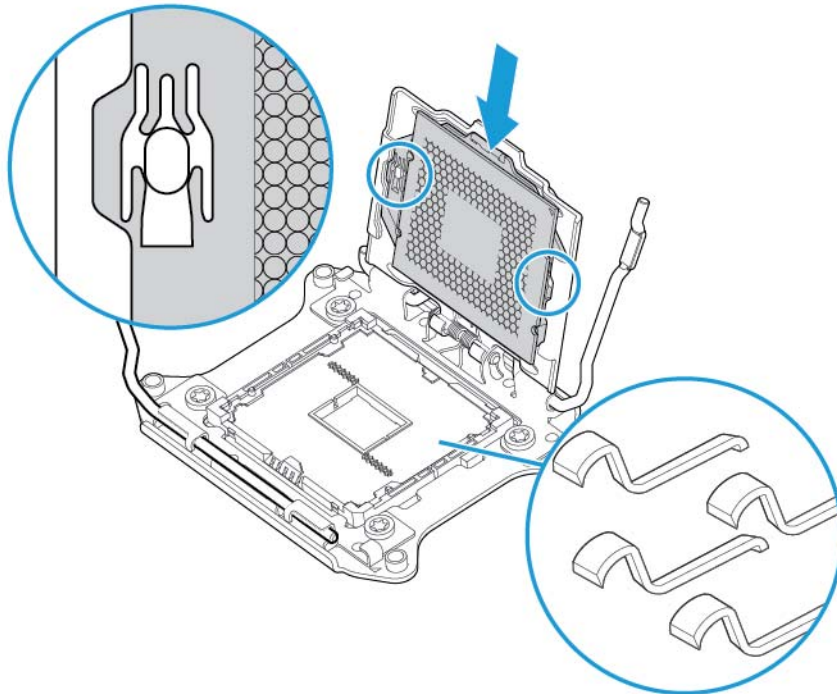

△ **CAUTION: THE PINS ON THE SYSTEM BOARD ARE VERY FRAGILE AND EASILY DAMAGED.** To avoid damage to the system board, do not touch the processor or the processor socket contacts.

2. Close the processor retaining bracket. When the processor is installed properly inside the processor retaining bracket, the processor retaining bracket clears the flange on the front of the socket.

△ **CAUTION:** Do not press down on the processor. Pressing down on the processor may cause damage to the processor socket and the system board. Press only in the area indicated on the processor retaining bracket.

3. Press and hold the processor retaining bracket in place, and then close each processor locking lever. Press only in the area indicated on the processor retaining bracket.

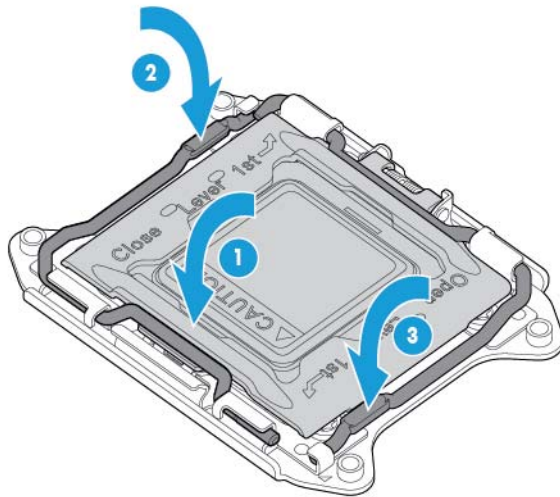

4. Align and install the heatsink.

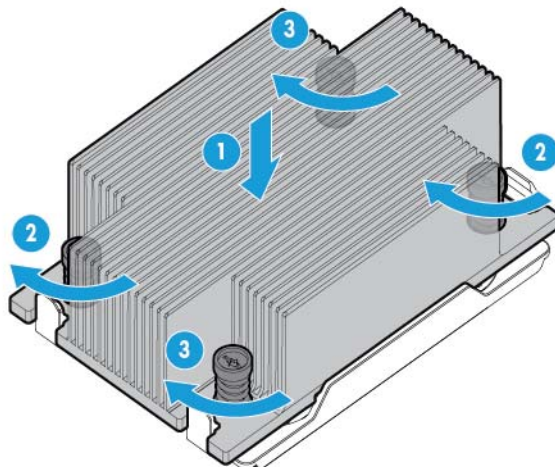

5. Install the access panel ("Access panel" on page 30).

DIMMs



IMPORTANT: This server does not support mixing RDIMMs and UDIMMs. Attempting to mix these two types causes the server to halt during BIOS initialization.

To identify the DIMMs installed in the server, see "DIMM slot locations (on page 87)."

To remove the component:

1. Power down the server (on page 25).
2. Remove all power:
 - a. Disconnect each power cord from the power source.
 - b. Disconnect each power cord from the server.
3. Do one of the following:
 - o Extend the server from the rack (on page 26).
 - o Remove the server from the rack (on page 26).
4. Remove the access panel ("Access panel" on page 30).
5. Remove the air baffle ("Air baffle" on page 31).
6. Remove the DIMM.

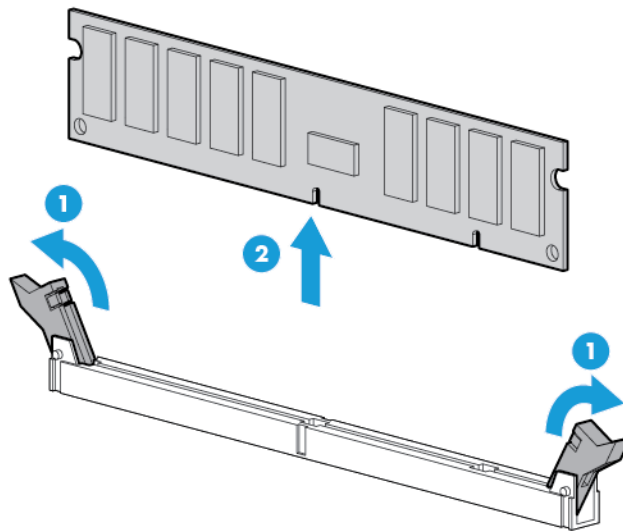

To replace the component, reverse the removal procedure.

For DIMM configuration information, see the server user guide.

HP Smart Storage Battery

To remove the component:

1. Power down the server (on page 25).
2. Remove all power:
 - a. Disconnect each power cord from the power source.

- b. Disconnect each power cord from the server.
3. Do one of the following:
 - o Extend the server from the rack (on page 26).
 - o Remove the server from the rack (on page 26).
4. Remove the access panel ("Access panel" on page 30).
5. Remove the air baffle ("Air baffle" on page 31).
6. Remove the fan cage ("Fan cage" on page 41).
7. Disconnect the cable, and then remove the HP Smart Storage Battery.

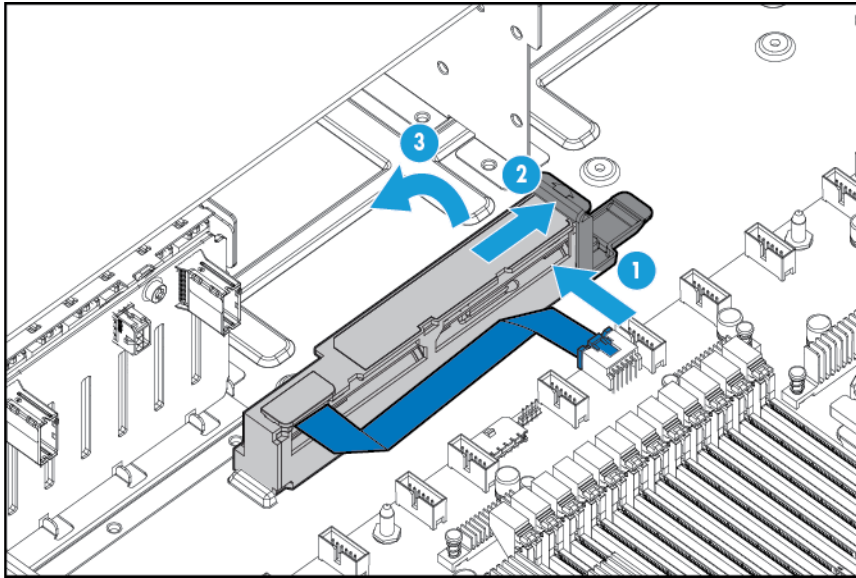

To replace the component, reverse the removal procedure.

HP Flexible Smart Array Controller

⚠ CAUTION: HP recommends performing a complete backup of all server data before performing a controller or adapter installation or removal.

To remove the component:

1. Power down the server (on page 25).
2. Remove all power:
 - a. Disconnect each power cord from the power source.
 - b. Disconnect each power cord from the server.
3. Do one of the following:
 - o Extend the server from the rack (on page 26).
 - o Remove the server from the rack (on page 26).
4. Remove the access panel ("Access panel" on page 30).
5. Remove the air baffle ("Air baffle" on page 31).
6. Disconnect the SAS cables.

7. Remove the controller.

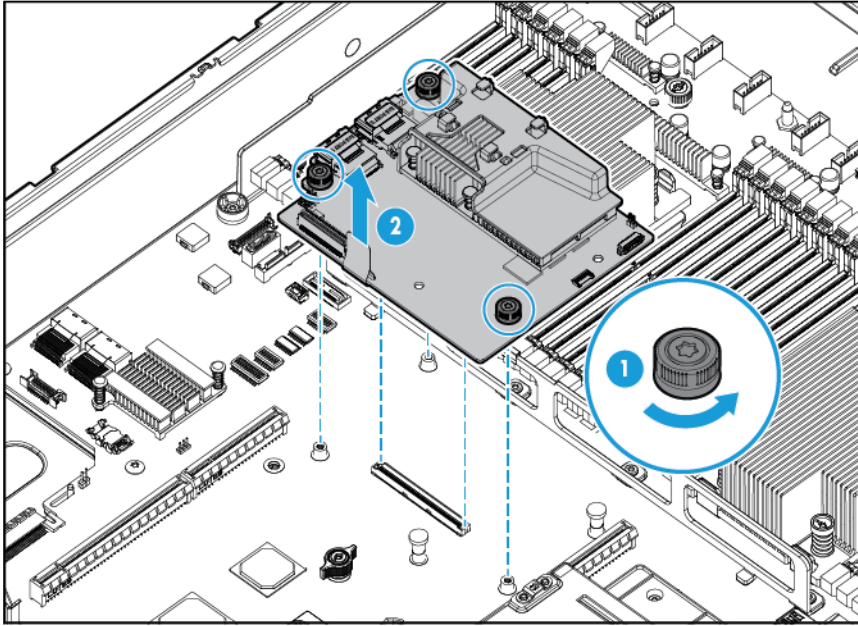

To replace the component, reverse the removal procedure.

System battery

If the server no longer automatically displays the correct date and time, you may need to replace the battery that provides power to the real-time clock.



WARNING: The computer contains an internal lithium manganese dioxide, a vanadium pentoxide, or an alkaline battery pack. A risk of fire and burns exists if the battery pack is not properly handled. To reduce the risk of personal injury:

- Do not attempt to recharge the battery.
- Do not expose the battery to temperatures higher than 60°C (140°F).
- Do not disassemble, crush, puncture, short external contacts, or dispose of in fire or water.
- Replace only with the spare designated for this product.

To remove the component:

1. Power down the server (on page 25).
2. Remove all power:
 - a. Disconnect each power cord from the power source.
 - b. Disconnect each power cord from the server.
3. Do one of the following:
 - o Extend the server from the rack (on page 26).
 - o Remove the server from the rack (on page 26).
4. Remove the access panel ("Access panel" on page 30).
5. If installed, remove the secondary PCIe riser cage ("Secondary PCIe riser cage" on page 34).
6. Locate the battery ("System board components" on page 85).

7. Remove the battery.

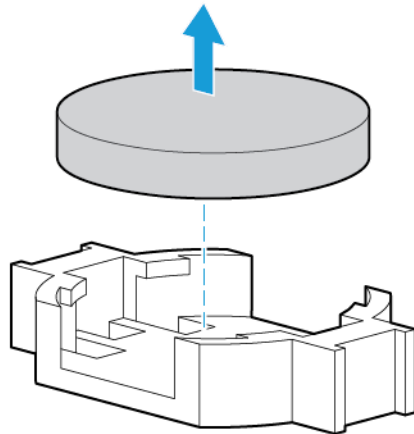

To replace the component, reverse the removal procedure.

For more information about battery replacement or proper disposal, contact an authorized reseller or an authorized service provider.

System board

To remove the component:

1. Power down the server (on page [25](#)).
2. Remove all power:
 - a. Disconnect each power cord from the power source.
 - b. Disconnect each power cord from the server.
3. Remove the server from the rack (on page [26](#)).
4. Remove all power supplies ("AC power supply" on page [37](#)).
5. Remove the access panel ("Access panel" on page [30](#)).
6. Remove the air baffle ("Air baffle" on page [31](#)).
7. Remove the PCIe riser cage.
8. If installed, remove the secondary PCIe riser cage ("Secondary PCIe riser cage" on page [34](#)).
9. Remove the FlexibleLOM ("FlexibleLOM" on page [42](#)).
10. Remove all DIMMs ("DIMMs" on page [57](#)).
11. Remove the fan cage ("Fan cage" on page [41](#)).
12. Disconnect all cables connected to the system board.
13. Remove the heatsink ("Heatsink" on page [51](#)).
14. Remove the processor ("Processor" on page [53](#)).
15. Loosen the system board thumbscrews.

16. Remove the system board, using the handle to lift it out of the chassis.

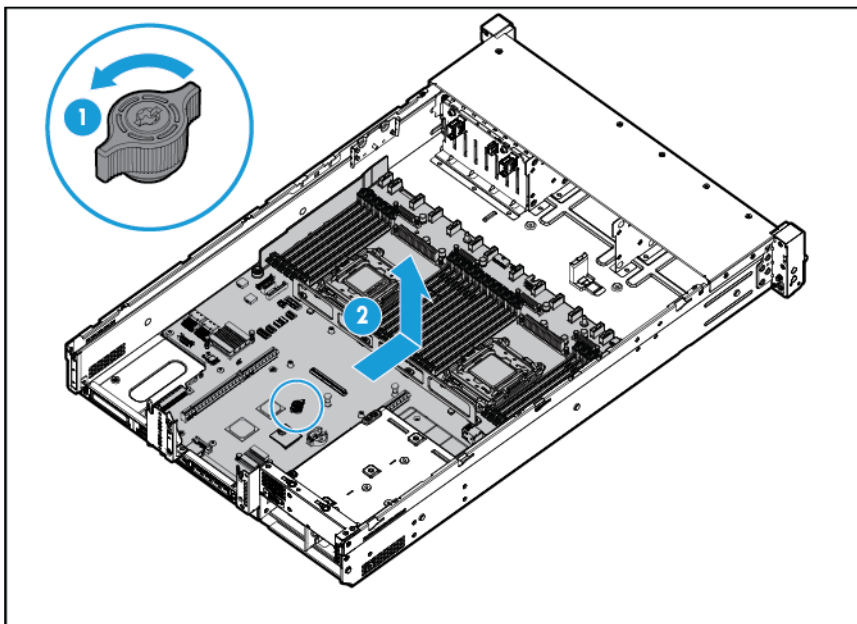

To replace the component:

1. Install the spare system board.

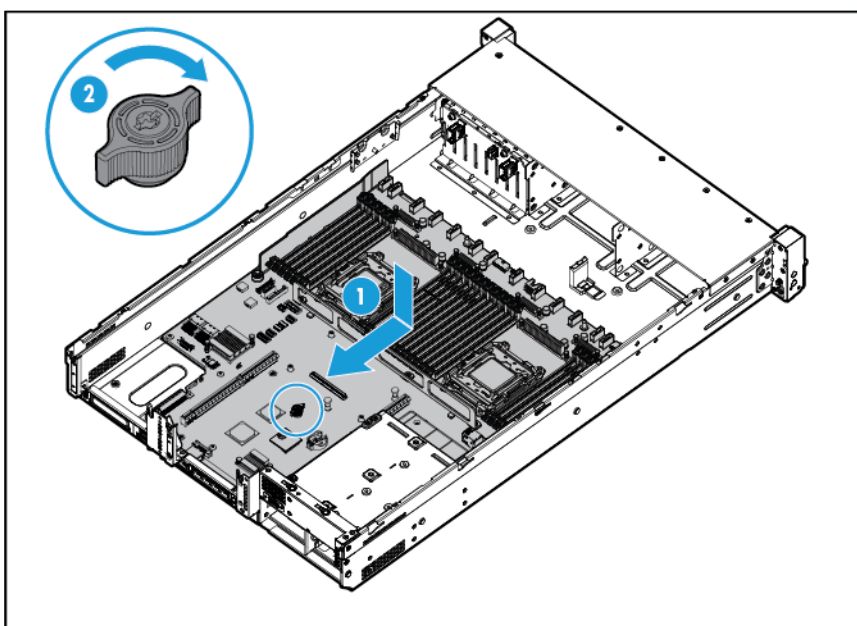

2. Open each of the processor locking levers in the order indicated in the following illustration, and then open the processor retaining bracket.

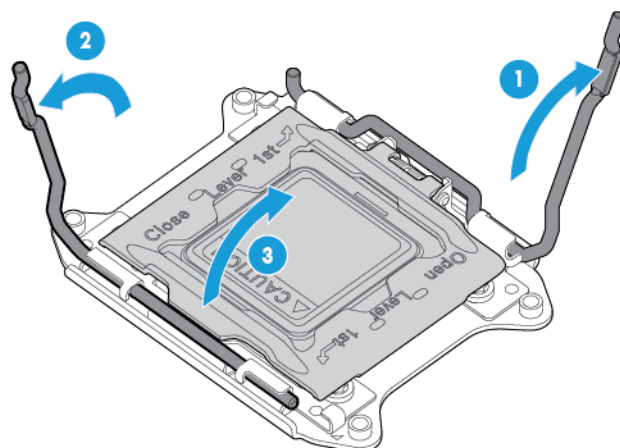

3. Remove the clear processor socket cover. Retain the processor socket cover for future use.

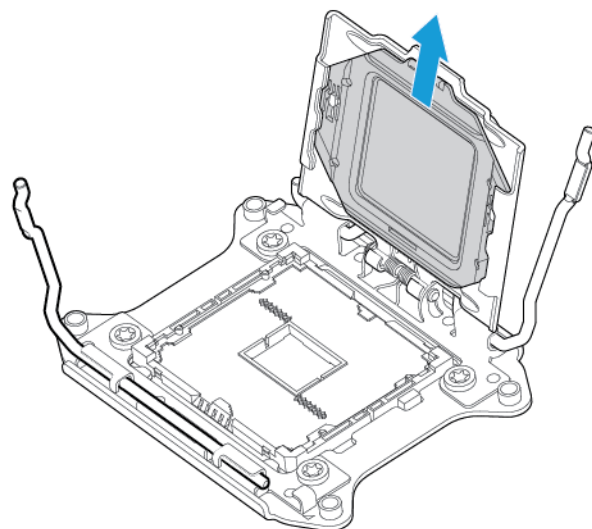

△ CAUTION: THE PINS ON THE SYSTEM BOARD ARE VERY FRAGILE AND EASILY DAMAGED. To avoid damage to the system board, do not touch the processor or the processor socket contacts.

4. Install the processor. Verify that the processor is fully seated in the processor retaining bracket by visually inspecting the processor installation guides on either side of the processor. **THE PINS ON THE SYSTEM BOARD ARE VERY FRAGILE AND EASILY DAMAGED.**

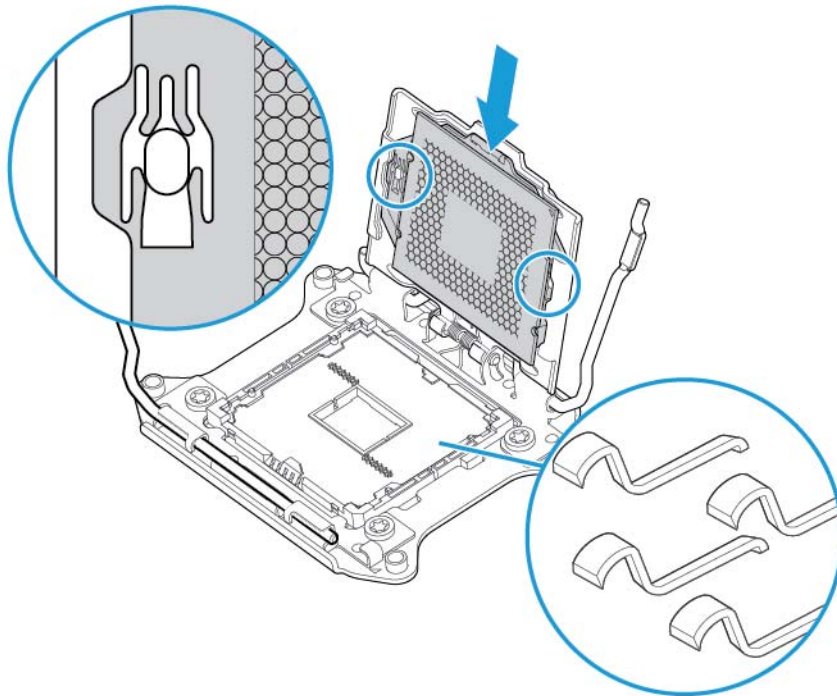

5. Close the processor retaining bracket. When the processor is installed properly inside the processor retaining bracket, the processor retaining bracket clears the flange on the front of the socket.

-
- △ **CAUTION:** Do not press down on the processor. Pressing down on the processor may cause damage to the processor socket and the system board. Press only in the area indicated on the processor retaining bracket.
-
- △ **CAUTION:** Close and hold down the processor cover socket while closing the processor locking levers. The levers should close without resistance. Forcing the levers closed can damage the processor and socket, requiring system board replacement.
-

6. Press and hold the processor retaining bracket in place, and then close each processor locking lever. Press only in the area indicated on the processor retaining bracket.

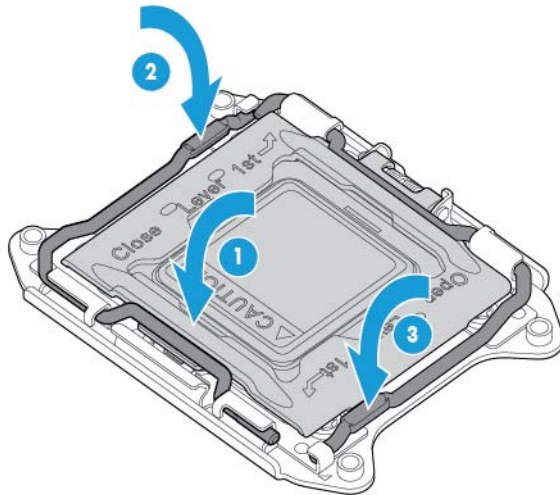

7. Install the processor socket cover onto the processor socket of the failed system board.
8. Clean the old thermal grease from the heatsink and the top of the processor with the alcohol swab. Allow the alcohol to evaporate before continuing.
9. Apply all the grease to the top of the processor in the following pattern to ensure even distribution.

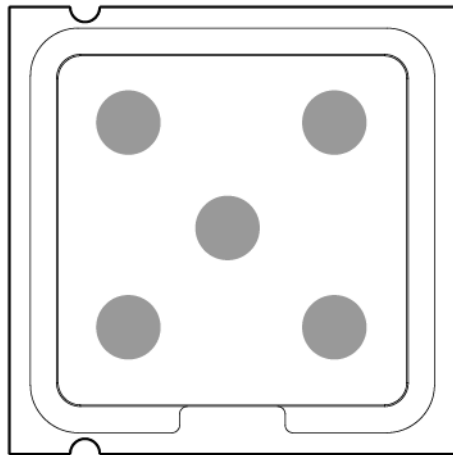

10. Install the heatsink.
NOTE: Heatsink appearance may vary.

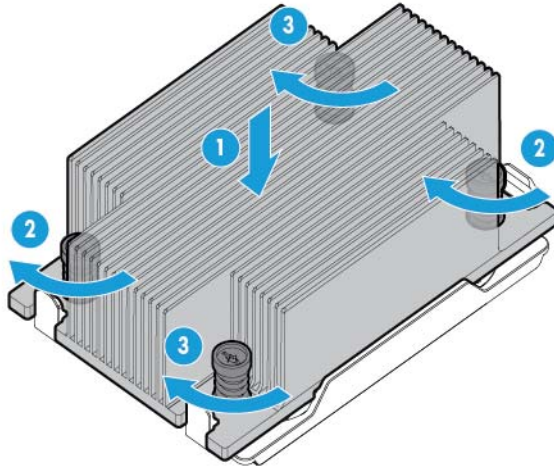

IMPORTANT: Install all components with the same configuration that was used on the failed system board.

11. Install all components removed from the failed system board.
12. Install the access panel.
13. Install the power supplies ("AC power supply" on page 37).
14. Power up the server.
15. Ensure all firmware, including option cards and embedded devices, is updated to the same versions to ensure the latest drivers are being used.
16. Re-enter any Secure Boot Keys that were previously added in the Secure Boot configuration (on page 71).

After you replace the system board, you must re-enter the server serial number and the product ID.

1. During the server startup sequence, press the **F9** key to access UEFI System Utilities.
2. Select the **System Configuration > BIOS/Platform Configuration (RBSU) > Advanced Options > Advanced System ROM Options > Serial Number**, and then press the **Enter** key.
3. Enter the serial number and press the **Enter** key. The following message appears:
The serial number should only be modified by qualified service personnel.
This value should always match the serial number located on the chassis.
4. Press the **Enter** key to clear the warning.
5. Enter the serial number and press the **Enter** key.
6. Select **Product ID**. The following warning appears:
Warning: The Product ID should ONLY be modified by qualified service personnel. This value should always match the Product ID located on the chassis.
7. Enter the product ID and press the **Enter** key.
8. Press the **F10** key to confirm exiting System Utilities. The server automatically reboots.

HP Trusted Platform Module

The TPM is not a customer-removable part.



CAUTION: Any attempt to remove an installed TPM from the system board breaks or disfigures the TPM security rivet. Upon locating a broken or disfigured rivet on an installed TPM, administrators should consider the system compromised and take appropriate measures to ensure the integrity of the system data.

If you suspect a TPM board failure, leave the TPM installed and remove the system board ("[System board](#)" on page [60](#)). Contact an HP authorized service provider for a replacement system board and TPM board.

Cabling

Eight-bay SFF front drive cage cabling

Bay 2 installation

- Connected to an HP 12G SAS Expander Card

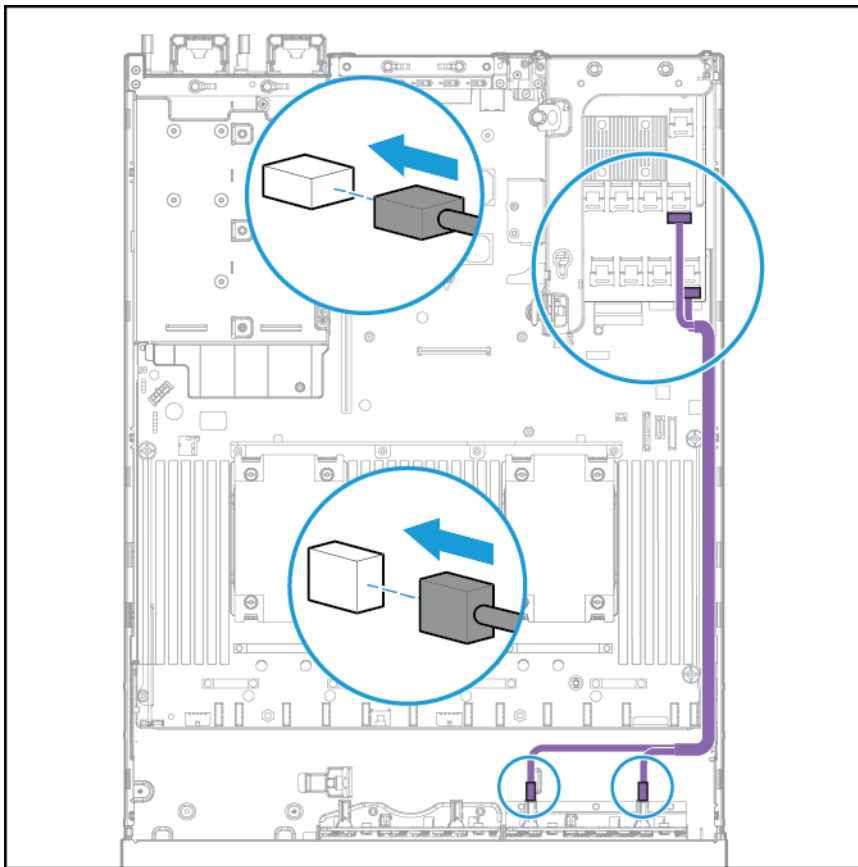

Universal media bay cabling

Connect the VGA cable to the optional VGA connector. Connect the USB cable to the front dual internal USB 3.0 connector.

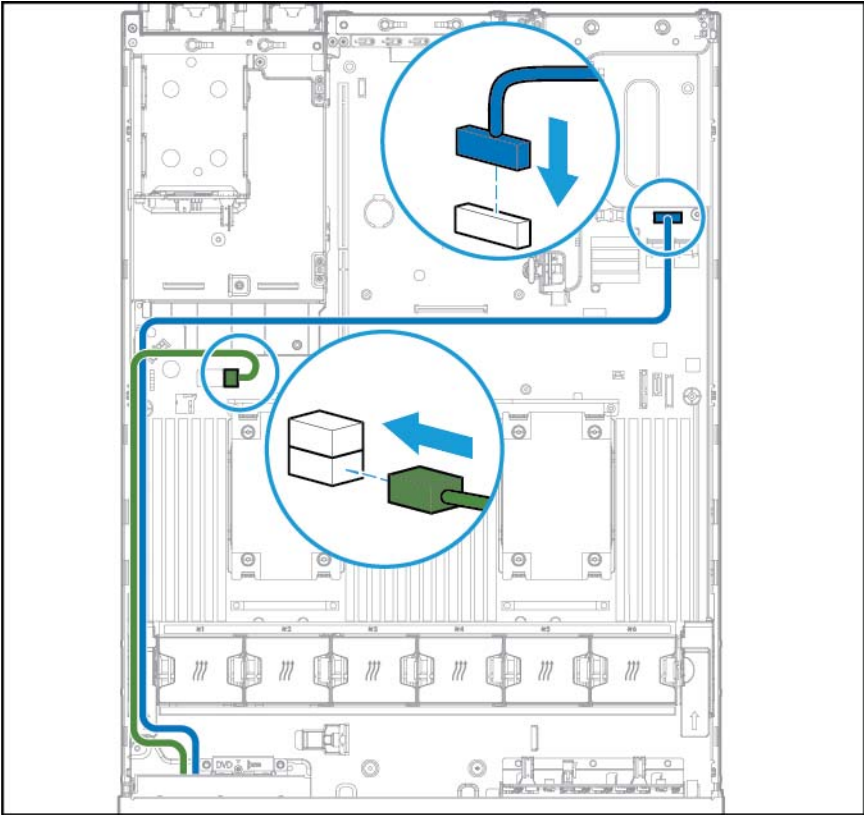

Connect the SATA optical drive cable to the front optical disk drive connector.

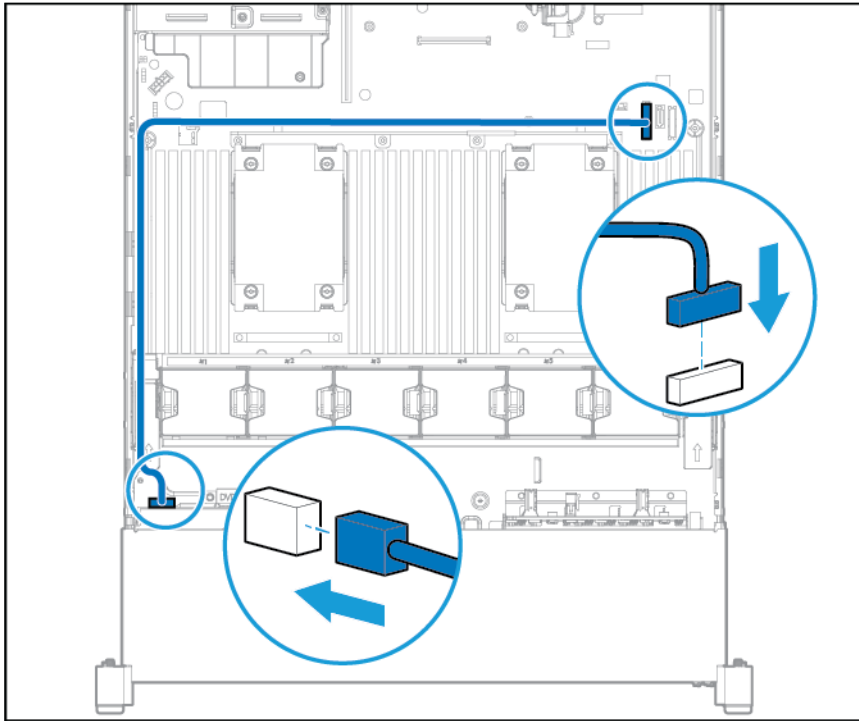

150W PCIe power cable option

⚠ **CAUTION:** To prevent damage to the server or expansion boards, power down the server and remove all AC power cords before removing or installing the PCI expansion cage.

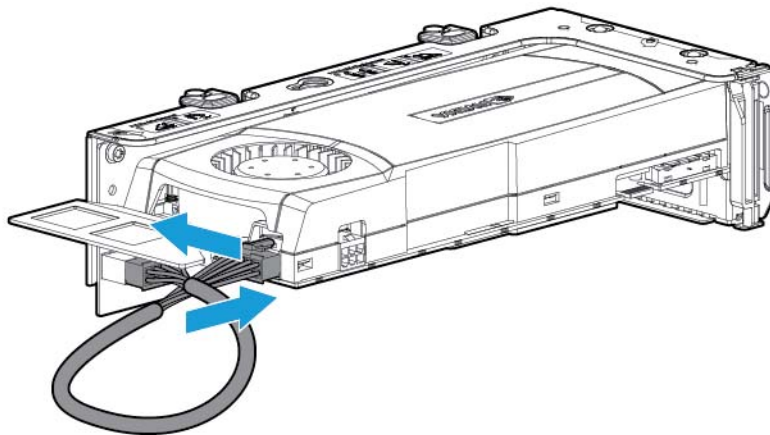

Diagnostic tools

HP UEFI System Utilities

The HP UEFI System Utilities is embedded in the system ROM. The UEFI System Utilities enable you to perform a wide range of configuration activities, including:

- Configuring system devices and installed options
- Enabling and disabling system features
- Displaying system information
- Selecting the primary boot controller
- Configuring memory options
- Selecting a language
- Launching other pre-boot environments such as the Embedded UEFI Shell and Intelligent Provisioning

For more information on the HP UEFI System Utilities, see the *HP UEFI System Utilities User Guide for HP ProLiant Gen9 Servers* on the HP website (<http://www.hp.com/go/ProLiantUEFI/docs>).

Scan the QR code located at the bottom of the screen to access mobile-ready online help for the UEFI System Utilities and UEFI Shell. For on-screen help, press **F1**.

Using HP UEFI System Utilities

To use the System Utilities, use the following keys.

Action	Key
Access System Utilities	F9 during server POST
Navigate menus	Up and Down arrows
Select items	Enter
Save selections	F10
Access Help for a highlighted configuration option*	F1

*Scan the QR code on the screen to access online help for the UEFI System Utilities and UEFI Shell.

Default configuration settings are applied to the server at one of the following times:

- Upon the first system power-up
- After defaults have been restored

Default configuration settings are sufficient for typical server operations; however, you can modify configuration settings as needed. The system prompts you for access to the System Utilities each time the system is powered up.

Flexible boot control

This feature enables you to do the following:

- Add Boot Options
 - Browse all FAT16 and FAT32 file systems.
 - Select an X64 UEFI application with an .EFI extension to add as a new UEFI boot option, such as an OS boot loader or other UEFI application.
The new boot option is appended to the boot order list. When you select a file, you are prompted to enter the boot option description (which is then displayed in the Boot menu), as well as any optional data to be passed to an .EFI application.
- Boot to System Utilities
Toward the end of the boot process, the boot options screen appears. This screen is visible for several seconds before the system attempts to boot from a supported boot device. During this time, you can access the System Utilities by pressing the **F9** key.
- Choose between supported modes: Legacy BIOS Boot Mode or UEFI Boot Mode



IMPORTANT: If the default boot mode settings are different than the user defined settings, the system may not boot the OS installation if the defaults are restored. To avoid this issue, use the User Defined Defaults feature in UEFI System Utilities to override the factory default settings.

For more information, see the *HP UEFI System Utilities User Guide for HP ProLiant Gen9 Servers* on the HP website (<http://www.hp.com/go/ProLiantUEFI/docs>).

Restoring and customizing configuration settings

You can reset all configuration settings to the factory default settings, or you can restore system default configuration settings, which are used instead of the factory default settings.

You can also configure default settings as necessary, and then save the configuration as the custom default configuration. When the system loads the default settings, it uses the custom default settings instead of the factory defaults.

Secure Boot configuration

Secure Boot is integrated in the UEFI specification on which the HP implementation of UEFI is based. Secure Boot is completely implemented in the BIOS and does not require special hardware. It ensures that each component launched during the boot process is digitally signed and that the signature is validated against a set of trusted certificates embedded in the UEFI BIOS. Secure Boot validates the software identity of the following components in the boot process:

- UEFI drivers loaded from PCIe cards
- UEFI drivers loaded from mass storage devices
- Pre-boot UEFI shell applications
- OS UEFI boot loaders

Once enabled, only firmware components and operating systems with boot loaders that have an appropriate digital signature can execute during the boot process. Only operating systems that support Secure Boot and have an EFI boot loader signed with one of the authorized keys can boot when Secure Boot is enabled. For

more information about supported operating systems, see the *HP UEFI System Utilities and Shell Release Notes* on the HP website (<http://www.hp.com/go/ProLiantUEFI/docs>).

A physically present user can customize the certificates embedded in the UEFI BIOS by adding/removing their own certificates.

Embedded UEFI shell

The system BIOS in all HP Gen9 servers includes an Embedded UEFI Shell in the ROM. The UEFI Shell environment provides an API, a command line prompt, and a set of CLIs that allow scripting, file manipulation, and system information. These features enhance the capabilities of the UEFI System Utilities.

For more information, see the following documents:

- *HP UEFI Shell User Guide for HP ProLiant Gen9 Servers* on the HP website (<http://www.hp.com/go/ProLiantUEFI/docs>)
- *UEFI Shell Specification* on the UEFI website (<http://www.uefi.org/specifications>)

Embedded Diagnostics option

The system BIOS in all HP Gen9 servers includes an Embedded Diagnostics option in the ROM. The Embedded Diagnostics option can run comprehensive diagnostics of the server hardware, including processors, memory, drives, and other server components.

For more information on the Embedded Diagnostics option, see the *HP UEFI System Utilities User Guide for HP ProLiant Gen9 Servers* on the HP website (<http://www.hp.com/go/ProLiantUEFI/docs>).

HP RESTful API support for UEFI

HP Gen9 servers include support for a UEFI compliant System BIOS, along with UEFI System Utilities and Embedded UEFI Shell pre-boot environments. HP Gen9 servers also support configuring the UEFI BIOS settings using the HP RESTful API, a management interface that server management tools can use to perform configuration, inventory, and monitoring of an HP server. A REST client uses HTTPS operations to configure supported server settings, such as UEFI BIOS settings.

For more information about the HP RESTful API and the HP RESTful Interface Tool, see the HP website (<http://www.hp.com/support/restfulinterface/docs>).

Re-entering the server serial number and product ID

After you replace the system board, you must re-enter the server serial number and the product ID.

1. During the server startup sequence, press the **F9** key to access UEFI System Utilities.
2. Select the **System Configuration > BIOS/Platform Configuration (RBSU) > Advanced Options > Advanced System ROM Options > Serial Number**, and then press the **Enter** key.
3. Enter the serial number and press the **Enter** key. The following message appears:
The serial number should only be modified by qualified service personnel.
This value should always match the serial number located on the chassis.
4. Press the **Enter** key to clear the warning.
5. Enter the serial number and press the **Enter** key.
6. Select **Product ID**. The following warning appears:

Warning: The Product ID should ONLY be modified by qualified service personnel. This value should always match the Product ID located on the chassis.

7. Enter the product ID and press the **Enter** key.
8. Press the **F10** key to confirm exiting System Utilities. The server automatically reboots.

HP Pre-boot Health Summary

If the server does not power on, you can use HP iLO to display diagnostic information on an external monitor. This feature is supported on servers that support external video and have a UID button. When power is available to the server but the server is not powered on, iLO runs on auxiliary power and can take control of the server video adapter to display the HP ProLiant Pre-boot Health Summary.

For additional information, see the *HP iLO 4 User Guide* on the HP website (<http://www.hp.com/go/ilo>) or the *HP ProLiant Gen9 Troubleshooting Guide, Volume I: Troubleshooting*.

The *HP ProLiant Gen9 Troubleshooting Guide, Volume I: Troubleshooting* provides procedures for resolving common problems and comprehensive courses of action for fault isolation and identification, issue resolution, and software maintenance on HP servers and server blades. To view the guide, select a language:

- English (http://www.hp.com/support/Gen9_TSG_en)
- French (http://www.hp.com/support/Gen9_TSG_fr)
- Spanish (http://www.hp.com/support/Gen9_TSG_es)
- German (http://www.hp.com/support/Gen9_TSG_de)
- Japanese (http://www.hp.com/support/Gen9_TSG_ja)
- Simplified Chinese (http://www.hp.com/support/Gen9_TSG_zh_cn)

HP Insight Diagnostics

HP Insight Diagnostics is a proactive server management tool, available in both offline and online versions, that provides diagnostics and troubleshooting capabilities to assist IT administrators who verify server installations, troubleshoot problems, and perform repair validation.

HP Insight Diagnostics Offline Edition performs various in-depth system and component testing while the OS is not running. To run this utility, boot the server using Intelligent Provisioning.

HP Insight Diagnostics Online Edition is a web-based application that captures system configuration and other related data needed for effective server management. Available in Microsoft Windows and Linux versions, the utility helps to ensure proper system operation.

For more information or to download the utility, see the HP website (<http://www.hp.com/servers/diags>). HP Insight Diagnostics Online Edition is also available in the SPP.

HP Insight Diagnostics survey functionality

HP Insight Diagnostics (on page 73) provides survey functionality that gathers critical hardware and software information on HP servers.

This functionality supports operating systems that are supported by the server. For operating systems supported by the server, see the HP website (<http://www.hp.com/go/supportos>).

If a significant change occurs between data-gathering intervals, the survey function marks the previous information and overwrites the survey data files to reflect the latest changes in the configuration.

Survey functionality is installed with every Intelligent Provisioning-assisted HP Insight Diagnostics installation, or it can be installed through the SPP.

Active Health System

HP Active Health System provides the following features:

- Combined diagnostics tools/scanners
- Always on, continuous monitoring for increased stability and shorter downtimes
- Rich configuration history
- Health and service alerts
- Easy export and upload to Service and Support

The HP Active Health System monitors and records changes in the server hardware and system configuration. The Active Health System assists in diagnosing problems and delivering rapid resolution if server failures occur.

The Active Health System collects the following types of data:

- Server model
- Serial number
- Processor model and speed
- Storage capacity and speed
- Memory capacity and speed
- Firmware/BIOS

HP Active Health System does not collect information about Active Health System users' operations, finances, customers, employees, partners, or data center, such as IP addresses, host names, user names, and passwords. HP Active Health System does not parse or change operating system data from third-party error event log activities, such as content created or passed through by the operating system.

The data that is collected is managed according to the HP Data Privacy policy. For more information see the HP website (<http://www.hp.com/go/privacy>).

The Active Health System, in conjunction with the system monitoring provided by Agentless Management or SNMP Pass-thru, provides continuous monitoring of hardware and configuration changes, system status, and service alerts for various server components.

The Agentless Management Service is available in the SPP, which can be downloaded from the HP website (<http://www.hp.com/go/spp/download>). The Active Health System log can be downloaded manually from HP iLO or HP Intelligent Provisioning and sent to HP.

For more information, see the following documents:

- *HP iLO User Guide* on the HP website (<http://www.hp.com/go/ilo/docs>)
- *HP Intelligent Provisioning User Guide* on the HP website (<http://www.hp.com/go/intelligentprovisioning/docs>)

Integrated Management Log

The IML records hundreds of events and stores them in an easy-to-view form. The IML timestamps each event with 1-minute granularity.

You can view recorded events in the IML in several ways, including the following:

- From within HP SIM
- From within operating system-specific IML viewers:
 - For Windows: IML Viewer
 - For Linux: IML Viewer Application
- From within the HP iLO web interface
- From within HP Insight Diagnostics (on page [73](#))

USB support

HP provides standard USB 2.0 support, standard USB 3.0 support, and legacy USB support. Standard support is provided by the OS through the appropriate USB device drivers.

Before the OS loads, HP provides support for USB 2.0 devices through legacy USB support, which is enabled by default in the system ROM. USB 3.0 ports are not functional before the OS loads. The native OS provides USB 3.0 support through appropriate xHCI drivers.

Legacy USB support provides USB functionality in environments where USB support is not available normally. Specifically, HP provides legacy USB functionality for the following:

- POST (system boot)
- UEFI System Utilities
- Pre-boot UEFI shell
- DOS
- Operating environments which do not provide native USB support

External USB functionality

HP provides external USB support to enable local connection of USB devices for server administration, configuration, and diagnostic procedures.

For additional security, external USB functionality can be disabled through USB options in UEFI System Utilities.

Internal USB functionality

An internal USB connector is available for use with security key devices and USB drive keys. This solution provides for use of a permanent USB key installed in the internal connector, avoiding issues of clearance on the front of the rack and physical access to secure data.

Troubleshooting

Troubleshooting resources

The *HP ProLiant Gen9 Troubleshooting Guide, Volume I: Troubleshooting* provides procedures for resolving common problems and comprehensive courses of action for fault isolation and identification, issue resolution, and software maintenance on HP servers and server blades. To view the guide, select a language:

- English (http://www.hp.com/support/Gen9_TSG_en)
- French (http://www.hp.com/support/Gen9_TSG_fr)
- Spanish (http://www.hp.com/support/Gen9_TSG_es)
- German (http://www.hp.com/support/Gen9_TSG_de)
- Japanese (http://www.hp.com/support/Gen9_TSG_ja)
- Simplified Chinese (http://www.hp.com/support/Gen9_TSG_zh_cn)

The *HP ProLiant Gen9 Troubleshooting Guide, Volume II: Error Messages* provides a list of error messages and information to assist with interpreting and resolving error messages on HP servers and server blades. To view the guide, select a language:

- English (http://www.hp.com/support/Gen9_EMG_en)
- French (http://www.hp.com/support/Gen9_EMG_fr)
- Spanish (http://www.hp.com/support/Gen9_EMG_es)
- German (http://www.hp.com/support/Gen9_EMG_de)
- Japanese (http://www.hp.com/support/Gen9_EMG_ja)
- Simplified Chinese (http://www.hp.com/support/Gen9_EMG_zh_cn)

Component identification

Front panel components

- SFF model (8-drive)

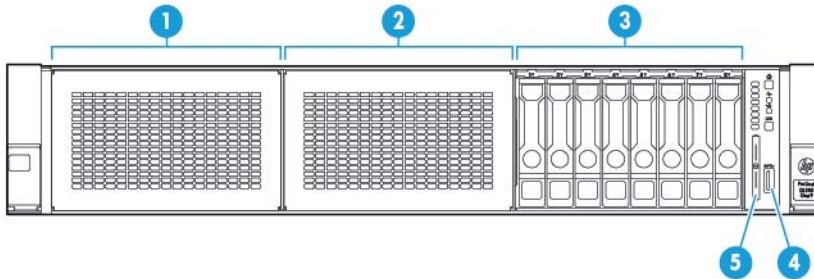

Item	Description
1	Bay 1 (optional drives or optical drive, video, USB)
2	Bay 2 (optional drives)
3	Fixed drive bays
4	Front USB 3.0 connector
5	Serial label pull tab

- SFF model (24-drive)

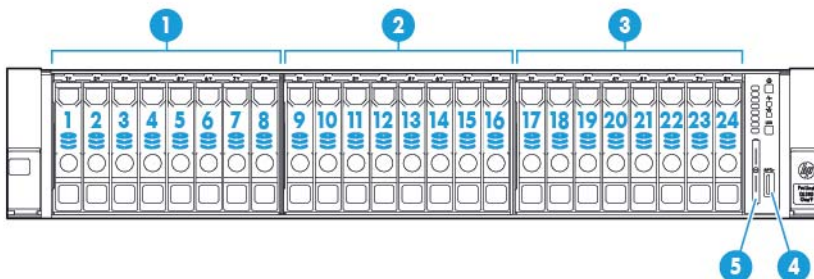

Item	Description
1	Bay 1
2	Bay 2
3	Bay 3, fixed drive bay
4	Front USB 3.0 connector
5	Serial label pull tab

- LFF model (12-drive)

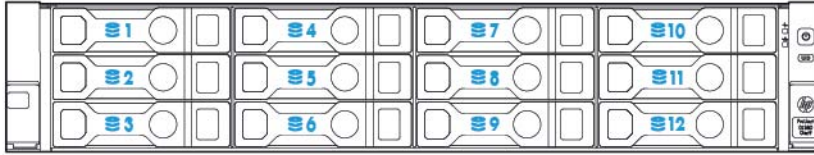

Item	Description
1-12	Drive bays

- LFF model (4-drive)

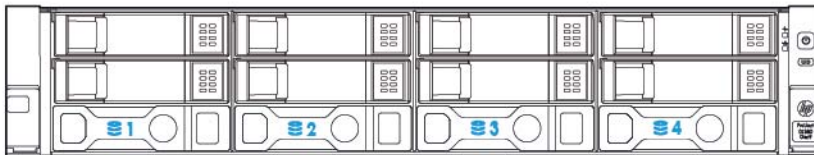

Item	Description
1-4	Drive bays

Front panel LEDs and buttons

- SFF front panel LEDs and button

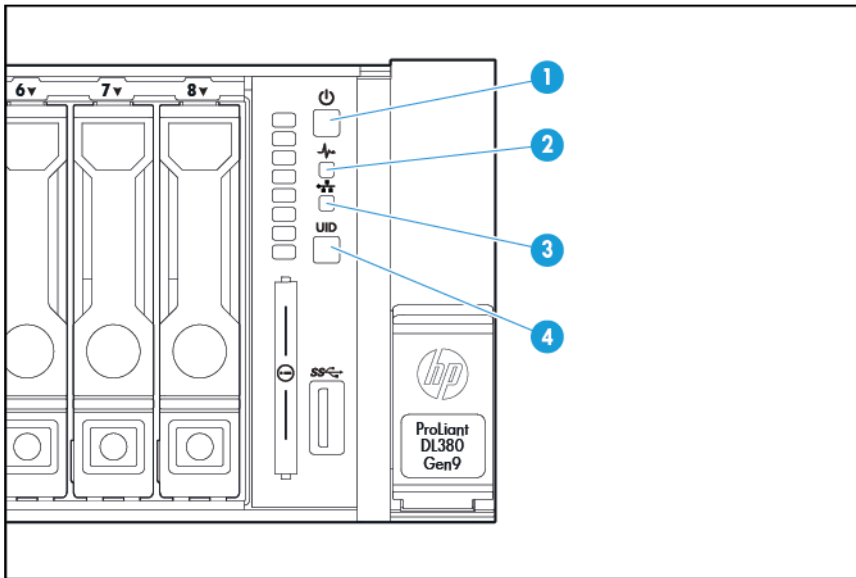

Item	Description	Status
1	Power On/Standby button and system power LED*	Solid green = System on Flashing green (1 Hz/cycle per sec) = Performing power on sequence Solid amber = System in standby Off = No power present**
2	Health LED*	Solid green = Normal Flashing green (1 Hz/cycle per sec) = iLO is rebooting Flashing amber = System degraded Flashing red (1 Hz/cycle per sec) = System critical†
3	NIC status LED*	Solid green = Link to network Flashing green (1 Hz/cycle per sec) = Network active Off = No network activity
4	UID button/LED*	Solid blue = Activated Flashing blue: <ul style="list-style-type: none"> 1 Hz/cycle per sec = Remote management or firmware upgrade in progress 4 Hz/cycle per sec = iLO manual reboot sequence initiated 8 Hz/cycle per sec = iLO manual reboot sequence in progress Off = Deactivated

*When all four LEDs described in this table flash simultaneously, a power fault has occurred. For more information, see "Power fault LEDs (on page 80)."

**Facility power is not present, power cord is not attached, no power supplies are installed, power supply failure has occurred, or the power button cable is disconnected.

†If the health LED indicates a degraded or critical state, review the system IML or use iLO to review the system health status.

- LFF LEDs and button

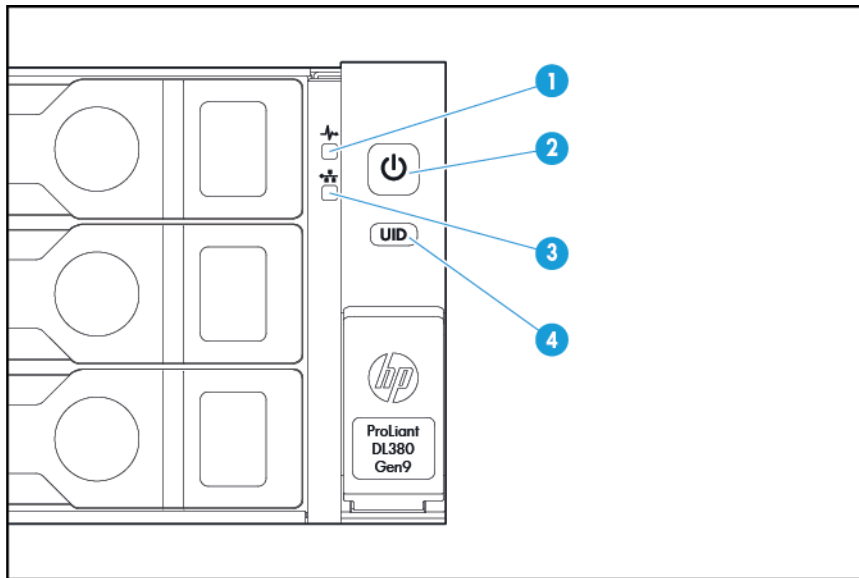

Item	Description	Status
1	Health LED*	Solid green = Normal Flashing green (1 Hz/cycle per sec) = iLO is rebooting Flashing amber = System degraded Flashing red (1 Hz/cycle per sec) = System critical**
2	Power On/Standby button and system power LED*	Solid green = System on Flashing green (1 Hz/cycle per sec) = Performing power on sequence Solid amber = System in standby Off = No power present†
3	NIC status LED*	Solid green = Link to network Flashing green (1 Hz/cycle per sec) = Network active Off = No network activity
4	UID button/LED*	Solid blue = Activated Flashing blue: <ul style="list-style-type: none"> 1 Hz/cycle per sec = Remote management or firmware upgrade in progress 4 Hz/cycle per sec = iLO manual reboot sequence initiated 8 Hz/cycle per sec = iLO manual reboot sequence in progress Off = Deactivated

*When all four LEDs described in this table flash simultaneously, a power fault has occurred. For more information, see "Power fault LEDs (on page 80)."

**If the health LED indicates a degraded or critical state, review the system IML or use iLO to review the system health status.

†Facility power is not present, power cord is not attached, no power supplies are installed, power supply failure has occurred, or the power button cable is disconnected.

Power fault LEDs

The following table provides a list of power fault LEDs, and the subsystems that are affected. Not all power faults are used by all servers.

Subsystem	LED behavior
System board	1 flash
Processor	2 flashes
Memory	3 flashes
Riser board PCIe slots	4 flashes
FlexibleLOM	5 flashes
Removable HP Flexible Smart Array controller/Smart SAS HBA controller	6 flashes
System board PCIe slots	7 flashes
Power backplane or storage backplane	8 flashes
Power supply	9 flashes

Systems Insight Display LEDs

The HP Systems Insight Display LEDs represent the system board layout. The display enables diagnosis with the access panel installed.

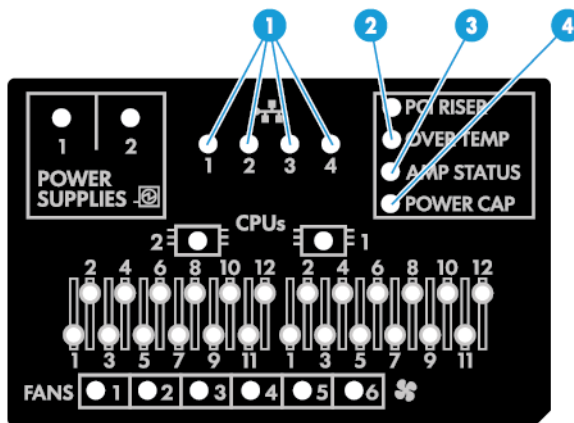

Item	Description	Status
1	NIC link/activity	Off = No link to network. If the power is off, view the rear panel RJ-45 LEDs for status (" Rear panel LEDs " on page 84). Flashing green = Network link and activity Solid green = Network link
2	Over temp	Off = Normal Solid amber = High system temperature detected

Item	Description	Status
3	AMP status	Off = AMP modes disabled Solid green = AMP mode enabled Solid amber = Failover Flashing amber = Invalid configuration
4	Power cap	Off = System is in standby, or no cap is set. Solid green = Power cap applied
—	All other LEDs	Off = Normal Amber = Failure For more information on the activation of these LEDs, see "Systems Insight Display LED combinations (on page 82)."

Systems Insight Display LED combinations

When the health LED on the front panel illuminates either amber or red, the server is experiencing a health event. Combinations of illuminated Systems Insight Display LEDs, the system power LED, and the health LED indicate system status.

Systems Insight Display LED and color	Health LED	System power LED	Status
Processor (amber)	Red	Amber	One or more of the following conditions may exist: <ul style="list-style-type: none"> • Processor in socket X has failed. • Processor X is not installed in the socket. • Processor X is unsupported. • ROM detects a failed processor during POST.
Processor (amber)	Amber	Green	Processor in socket X is in a pre-failure condition.
DIMM (amber)	Red	Green	One or more DIMMs have failed.
DIMM (amber)	Amber	Green	DIMM in slot X is in a pre-failure condition.
Over temp (amber)	Amber	Green	The Health Driver has detected a cautionary temperature level.
Over temp (amber)	Red	Amber	The server has detected a hardware critical temperature level.
PCI riser (amber)	Red	Green	The PCI riser cage is not seated properly.
Fan (amber)	Amber	Green	One fan has failed or has been removed.
Fan (amber)	Red	Green	Two or more fans have failed or been removed.
Power supply (amber)	Red	Amber	One or more of the following conditions may exist: <ul style="list-style-type: none"> • Only one power supply is installed and that power supply is in standby. • Power supply fault • System board fault
Power supply (amber)	Amber	Green	One or more of the following conditions may exist: <ul style="list-style-type: none"> • Redundant power supply is installed and only one power supply is functional. • AC power cord is not plugged into redundant power supply. • Redundant power supply fault

Systems Insight Display LED and color	Health LED	System power LED	Status
			<ul style="list-style-type: none"> Power supply mismatch at POST or power supply mismatch through hot-plug addition
Power cap (off)	—	Amber	Standby
Power cap (green)	—	Flashing green	Waiting for power
Power cap (green)	—	Green	Power is available.
Power cap (flashing amber)	—	Amber	Power is not available.



IMPORTANT: If more than one DIMM slot LED is illuminated, further troubleshooting is required. Test each bank of DIMMs by removing all other DIMMs. Isolate the failed DIMM by replacing each DIMM in a bank with a known working DIMM.

Rear panel components

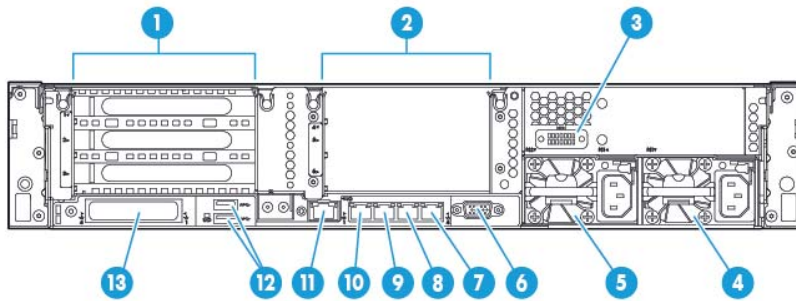

Item	Description
1	PCIe slots 1–3 (top to bottom)
2	Optional PCIe slots 4–6 (top to bottom)*
3	Optional serial port
4	Power supply 1 (PS1)
5	Power supply 2 (PS2)
6	Video connector
7	1Gb RJ-45 port 4
8	1Gb RJ-45 port 3
9	1Gb RJ-45 port 2
10	1Gb RJ-45 port 1
11	iLO connector
12	USB 3.0 connectors
13	FlexibleLOM option

*Requires second processor

Rear panel LEDs

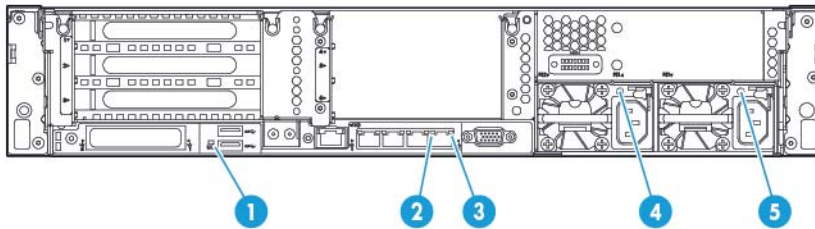

Item	Description	Status
1	UID LED	Off = Deactivated Solid blue = Activated Flashing blue = System being managed remotely
2	NIC link LED	Off = No network link Green = Network link
3	NIC activity LED	Off = No network activity Solid green = Link to network Flashing green = Network activity
4	Power supply 2 LED	Off = System is off or power supply has failed. Solid green = Normal
5	Power supply 1 LED	Off = System is off or power supply has failed. Solid green = Normal

Non-hot-plug PCI riser board slot definitions

- Primary riser cage connector, connected to processor 1 or the Southbridge

	PCIe 3-slot riser cage*	Optional PCIe 2-slot x16 riser cage
1 - FL/FH	PCIe3 x16 (8,4,2,1)	—
2 - HL/FH	PCIe3 x16 (8,4,2,1)	PCIe3 x16 (16,8,4,2,1)
3 - HL/FH	PCIe3 x8 (8,4,2,1)	PCIe3 x8 (8,4,2,1)

- Secondary riser cage connector, connected to processor 2 (processor 2 must be installed)

	PCIe 3-slot riser cage*
4 - FL/FH	PCIe3 x16 (16,8,4,2,1)
5 - HL/FH	PCIe3 x16 (16,8,4,2,1)
6 - HL/FH	PCIe3 x8 (8,4,2,1)

*The server ships with one PCIe3 riser cage installed in the primary riser cage connector.

Notes:

- "Primary" denotes the riser cage is installed in the primary riser connector.
- "Secondary" denotes the riser cage is installed in the secondary riser connector.

- Installing the riser cages listed in the table above in either the primary or secondary riser connectors determines the form factor of the PCI expansion boards supported by those riser cages.
- FL/FH denotes full-length, full-height. HL/FH denotes half-length, full-height.

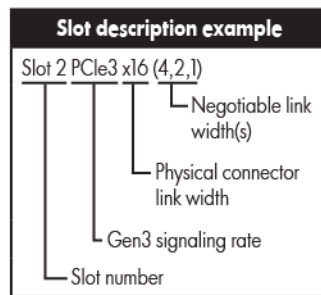

System board components

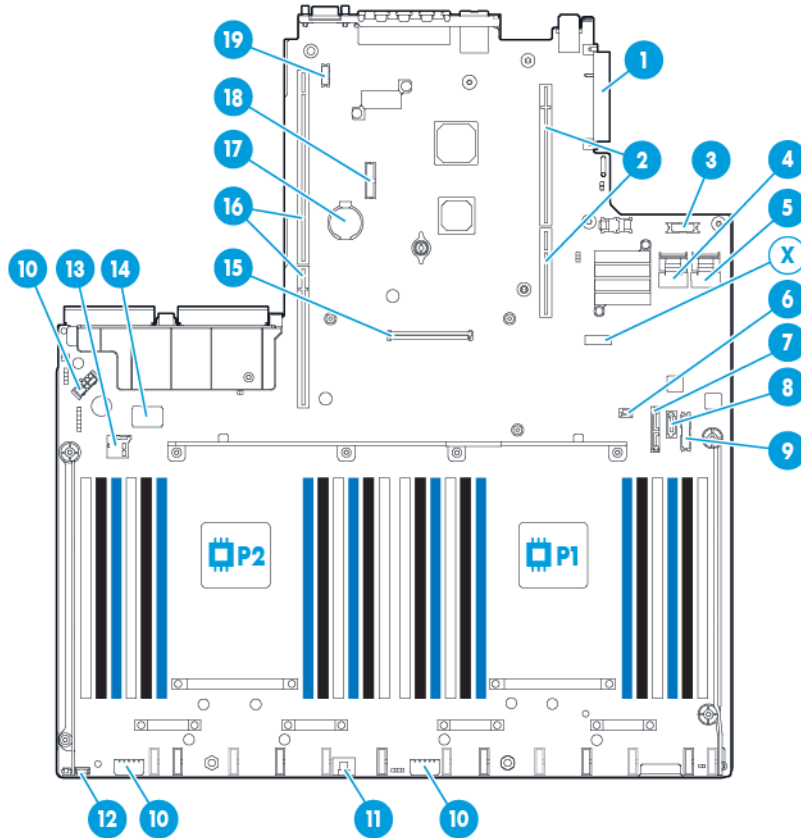

Item	Description
1	FlexibleLOM connector
2	Primary (processor 1) PCI riser connector
3	Optical front VGA/USB 2.0 connector
4	x4 SATA port 1

Item	Description
5	x4 SATA port 2
6	Backplane presence detect connector
7	Optical/SATA port 5
8	SATA port 4
9	Front power/USB 3.0 connector
10	Drive backplane power connector
11	HP Smart Storage Battery connector
12	Optional Location Discovery Services connector
13	Micro SD card slot
14	Dual internal USB 3.0 connector
15	Smart Array/HBA connector
16	Secondary processor (processor 2) PCI riser connector
17	System battery
18	TPM connector
19	Optional serial port connector
X	System maintenance switch

System maintenance switch

Position	Default	Function
S1	Off	Off = iLO security is enabled. On = iLO security is disabled.
S2	Off	Off = System configuration can be changed. On = System configuration is locked.
S3	Off	Reserved
S4	Off	Reserved
S5	Off	Off = Power-on password is enabled. On = Power-on password is disabled.
S6	Off	Off = No function. On = ROM reads system configuration as invalid.
S7	Off	Off = Set default boot mode to UEFI. On = Set default boot mode to legacy.
S8	—	Reserved
S9	—	Reserved
S10	—	Reserved
S11	—	Reserved
S12	—	Reserved

To access the redundant ROM, set S1, S5, and S6 to on.

When the system maintenance switch position 6 is set to the On position, the system is prepared to erase all system configuration settings from both CMOS and NVRAM.



CAUTION: Clearing CMOS and/or NVRAM deletes configuration information. Be sure to properly configure the server or data loss could occur.

NMI functionality

An NMI crash dump enables administrators to create crash dump files when a system is hung and not responding to traditional debug mechanisms.

Crash dump log analysis is an essential part of diagnosing reliability problems, such as hangs in operating systems, device drivers, and applications. Many crashes freeze a system, and the only available action for administrators is to cycle the system power. Resetting the system erases any information that could support problem analysis, but the NMI feature preserves that information by performing a memory dump before a hard reset.

To force the OS to invoke the NMI handler and generate a crash dump log, the administrator can use the iLO Virtual NMI feature.

For more information, see the HP website (<http://www.hp.com/support/NMI>).

DIMM slot locations

DIMM slots are numbered sequentially (1 through 12) for each processor. The supported AMP modes use the letter assignments for population guidelines.

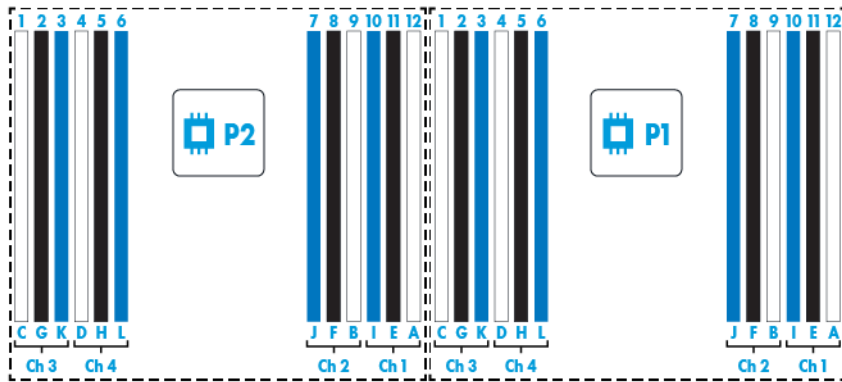

	1st slot of channel	2nd slot of channel	3rd slot of channel
	A B C D	E F G H	I J K L
Number of DIMMs to install	4	8	12

SAS and SATA device numbers

- SFF 8-device bay numbering

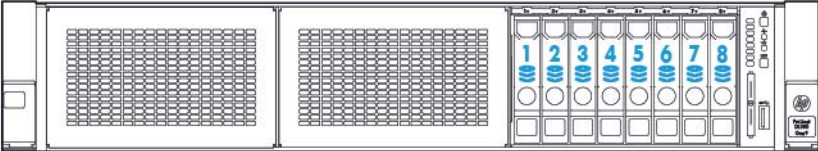

- SFF 8-device bay numbering with SAS expander solution used

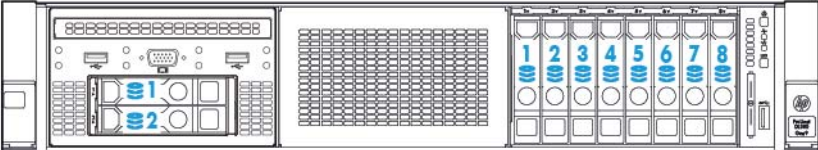

- Optional SFF 16-device bay numbering

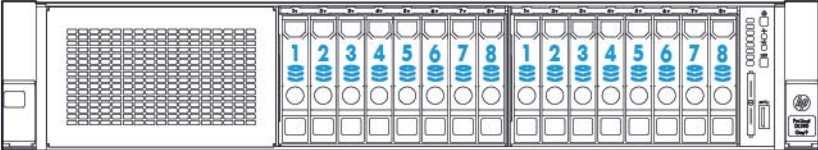

- Optional SFF 16-device bay numbering with SAS expander solution used

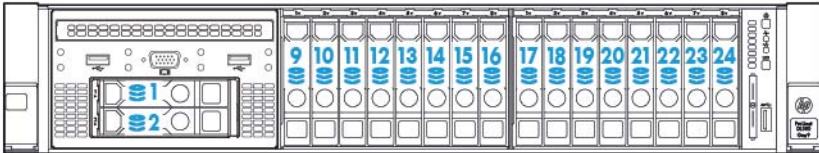

- Optional 24 SFF device bay numbering

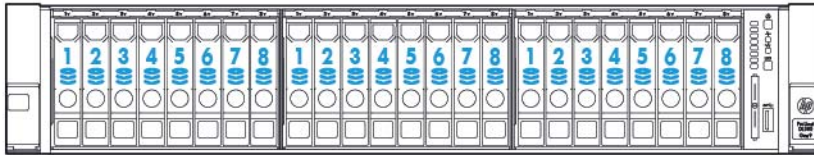

- Optional 24 SFF device bay numbering with SAS expander solution used

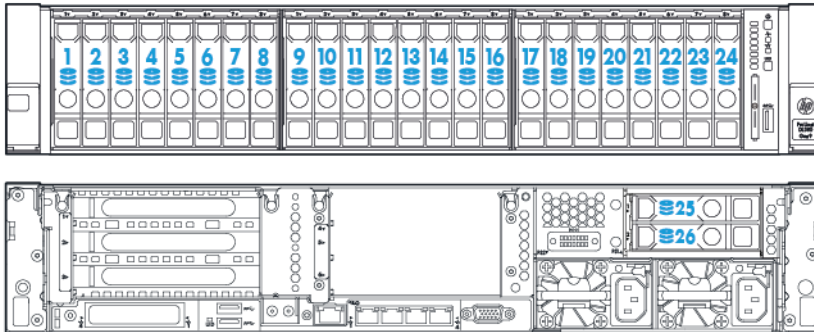

- LFF 12-device bay numbering

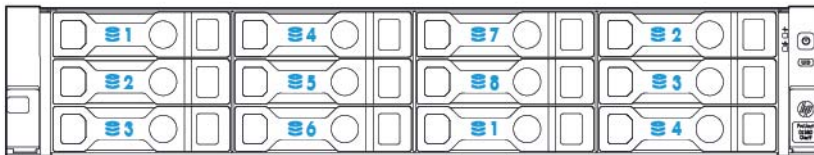

- LFF 12-device bay number with 2-bay rear SAS expander solution used

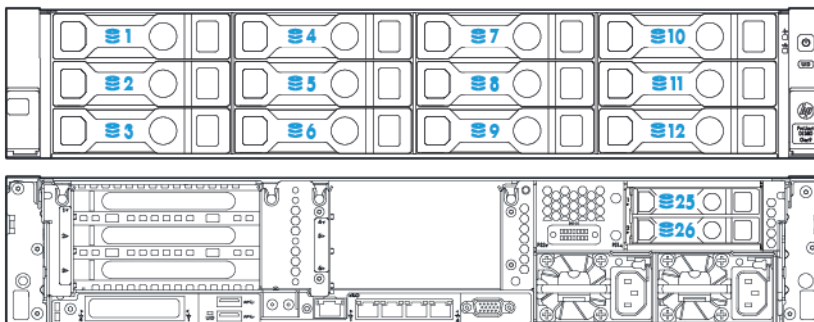

- LFF 12-device bay number with 3-bay rear SAS expander solution used

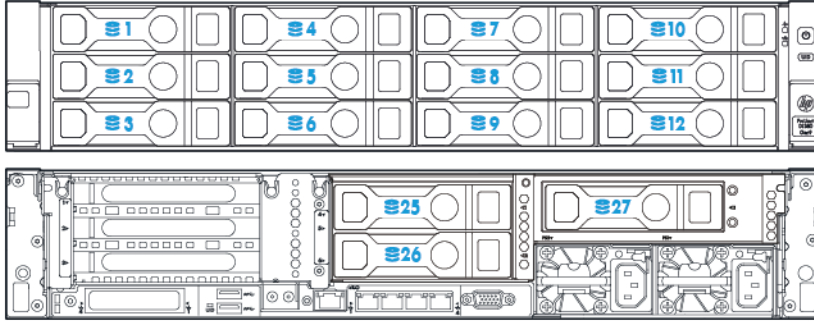

- LFF 4-device bay numbering

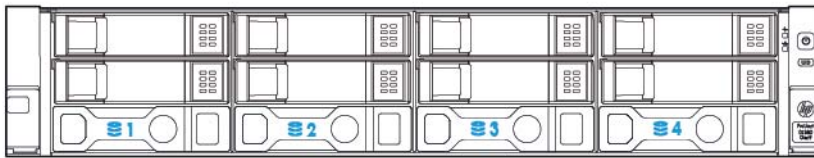

Hot-plug drive LED definitions

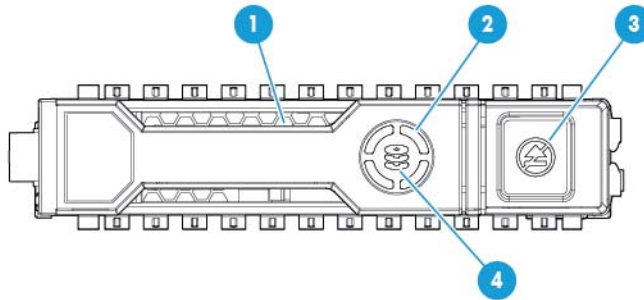

Item	LED	Status	Definition
1	Locate	Solid blue	The drive is being identified by a host application.
		Flashing blue	The drive carrier firmware is being updated or requires an update.
2	Activity ring	Rotating green	Drive activity
		Off	No drive activity
3	Do not remove	Solid white	Do not remove the drive. Removing the drive causes one or more of the logical drives to fail.
		Off	Removing the drive does not cause a logical drive to fail.
4	Drive status	Solid green	The drive is a member of one or more logical drives.

Item	LED	Status	Definition
		Flashing green	The drive is rebuilding or performing a RAID migration, strip size migration, capacity expansion, or logical drive extension, or is erasing.
		Flashing amber/green	The drive is a member of one or more logical drives and predicts the drive will fail.
		Flashing amber	The drive is not configured and predicts the drive will fail.
		Solid amber	The drive has failed.
		Off	The drive is not configured by a RAID controller.

Hot-plug fans

- △ **CAUTION:** To avoid damage to server components, fan blanks must be installed in fan bays 1 and 2 in a single-processor configuration.
- △ **CAUTION:** To avoid damage to the equipment, do not operate the server for extended periods of time if the server does not have the optimal number of fans installed. Although the server might boot, HP does not recommend operating the server without the required fans installed and operating.

Valid fan configurations are listed in the following table.

Configuration	Fan bay 1	Fan bay 2	Fan bay 3	Fan bay 4	Fan bay 5	Fan bay 6
1 processor	Fan blank	Fan blank	Fan	Fan	Fan	Fan
1 processor, 24 SFF or 12 LFF configuration with high performance fans	Fan	Fan	Fan	Fan	Fan	Fan
2 processors	Fan	Fan	Fan	Fan	Fan	Fan

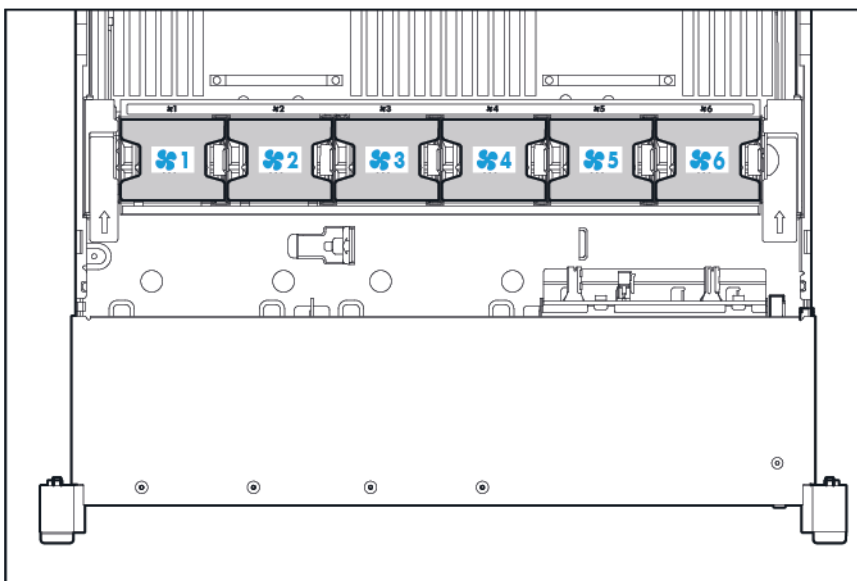

For a single-processor configuration, excluding 24-SFF and 12-LFF configurations, four fans and two blanks are required in specific fan bays for redundancy. A fan failure or missing fan causes a loss of redundancy. A second fan failure or missing fan causes an orderly shutdown of the server.

For a dual-processor configuration and single-processor 24-SFF or 12-LFF configurations, six fans are required for redundancy. A fan failure or missing fan causes a loss of redundancy. A second fan failure or missing fan causes an orderly shutdown of the server.

The high performance fan option might be necessary for the following installations:

- Optional GPU riser installations
- ASHRAE compliant configurations

For more information, see the HP website (<http://www.hp.com/servers/ASHRAE>).

The server supports variable fan speeds. The fans operate at minimum speed until a temperature change requires a fan speed increase to cool the server. The server shuts down during the following temperature-related scenarios:

- At POST and in the OS, HP iLO performs an orderly shutdown if a cautionary temperature level is detected. If the server hardware detects a critical temperature level before an orderly shutdown occurs, the server performs an immediate shutdown.
- When the Thermal Shutdown feature is disabled in the BIOS/Platform Configuration (RBSU), HP iLO does not perform an orderly shutdown when a cautionary temperature level is detected. Disabling this feature does not disable the server hardware from performing an immediate shutdown when a critical temperature level is detected.



CAUTION: A thermal event can damage server components when the Thermal Shutdown feature is disabled in the BIOS/Platform Configuration (RBSU).

Specifications

Environmental specifications

Specification	Value
Temperature range*	—
Operating	10°C to 35°C (50°F to 95°F)
Nonoperating	-30°C to 60°C (-22°F to 140°F)
Relative humidity (noncondensing)	—
Operating	Minimum to be the higher (more moisture) of -12°C (10.4°F) dew point or 8% relative humidity Maximum to be 24°C (75.2°F) dew point or 90% relative humidity
Nonoperating	5% to 95% 38.7°C (101.7°F), maximum wet bulb temperature

* All temperature ratings shown are for sea level. An altitude derating of 1.0°C per 304.8 m (1.8°F per 1000 ft) to 3048 m (10,000 ft) is applicable. No direct sunlight allowed. Maximum rate of change is 20°C per hour (36°F per hour). The upper limit and rate of change might be limited by the type and number of options installed.

For certain approved hardware configurations, the supported system inlet temperature range is extended:

- 5°C to 10°C (41°F to 50°F) and 35°C to 40°C (95°F to 104°F) at sea level with an altitude derating of 1.0°C per every 175 m (1.8°F per every 574 ft) above 900 m (2953 ft) to a maximum of 3048 m (10,000 ft).
- 40°C to 45°C (104°F to 113°F) at sea level with an altitude derating of 1.0°C per every 125 m (1.8°F per every 410 ft) above 900 m (2953 ft) to a maximum of 3048 m (10,000 ft).

The approved hardware configurations for this system are listed on the HP website (<http://www.hp.com/servers/ASHRAE>).

Mechanical specifications

Specification	Value
Height	8.73 cm (3.44 in)
Depth, SFF	67.94 cm (26.75 in)
Depth, LFF	73.02 cm (28.75 in)
Width	44.54 cm (17.54 in)
Weight (maximum—all SFF drives)*	14.7 kg (32.6 lb)
Weight (minimum—one LFF drive)**	23.6 kg (51.5 lb)

*The SFF configuration includes the following components:

- SFF drive (1)
- Drive blanks (7)
- Drive bay blanks for bays 1 and 2 (2)
- Fan assemblies (4)
- Fan blanks (2)
- Standard heatsink (1)
- 1P air baffle (1)
- X8 HP Flexible Smart Array Controller (1)
- Primary riser cage (1)
- Secondary riser cage blank (1)
- Power supply (1)
- Power supply blank (1)
- Cables for the above components

**The LFF configuration includes the following components:

- LFF drives (12)
- Fan assemblies (6)
- SE heatsinks (2)
- 2P air baffle (1)
- X8 HP Flexible Smart Array Controller (1)
- Primary riser cage (1)
- Secondary riser cage (1)
- Power supplies (2)
- Cables for the above components

The 12 LFF configuration does not contain a rear three-bay LFF drive cage option.

Power supply specifications

Depending on installed options, the server is configured with one of the following power supplies:

- HP 500W Flex Slot Platinum Hot-plug Power Supply (on page 95)
- HP 800W Flex Slot Platinum Hot-plug Power Supply (on page 95)
- HP 1400W Flex Slot Platinum Plus Hot-plug Power Supply (on page 95)

For detailed power supply specifications, see the HP website (<http://www.hp.com/go/proliant/powersupply>).

HP 500W Flex Slot Platinum Hot-plug Power Supply

Specification	Value
Input requirements	
Rated input voltage	100 to 120 VAC 200 to 240 VAC 240 VDC for China only
Rated input frequency	50 Hz to 60 Hz
Rated input current	5.8 A at 100 VAC 2.8 A at 200 VAC 2.4 A at 240 VDC
Maximum rated input power	580 W at 100 VAC 560 W at 200 VAC
BTUs per hour	1979 at 100 VAC 1911 at 200 VAC
Power supply output	
Rated steady-state power	500 W at 100 VAC to 120 VAC input 500 W at 200 VAC to 240 VAC input
Maximum peak power	500 W at 100 VAC to 120 VAC input 500 W at 200 VAC to 240 VAC input

HP 800W Flex Slot Platinum Hot-plug Power Supply

Specification	Value
Input requirements	
Rated input voltage	100 to 120 VAC 200 to 240 VAC 240 VDC for China only
Rated input frequency	50 Hz to 60 Hz
Rated input current	9.4 A at 100 VAC 4.5 A at 200 VAC 3.8 A at 240 VDC
Maximum rated input power	940 W at 100 VAC 900 W at 200 VAC
BTUs per hour	3207 at 100 VAC 3071 at 200 VAC
Power supply output	
Rated steady-state power	800 W at 100 VAC to 120 VAC input 800 W at 200 VAC to 240 VAC input
Maximum peak power	800 W at 100 VAC to 120 VAC input 800 W at 200 VAC to 240 VAC input

HP 1400W Flex Slot Platinum Plus Hot-plug Power Supply

Specification	Value
Input requirements	
Rated input voltage	200 to 240 VAC
Rated input frequency	50 Hz to 60 Hz
Rated input current	8.0 A at 200 VAC 6.7 A at 240 VAC
Maximum rated input power	1600 W at 200 VAC 1600 W at 240 VAC
BTUs per hour	5459 at 200 VAC 5459 at 240 VAC
Power supply output	
Rated steady-state power	1400 W at 200 VAC to 240 VAC input
Maximum peak power	1400 W at 200 VAC to 240 VAC input

Acronyms and abbreviations

AMP

Advanced Memory Protection

FBWC

flash-backed write cache

FDR

fourteen data rate

FIO

Factory Integrated Option

FLR

FlexibleLOM for rack servers

FLR-SFP

FlexibleLOM for rack servers with an SFP+ connector

HP SIM

HP Systems Insight Manager

iLO

Integrated Lights-Out

IML

Integrated Management Log

LFF

large form factor

NEBS

Network Equipment-Building System

NMI

nonmaskable interrupt

NVRAM

nonvolatile memory

PCIe

Peripheral Component Interconnect Express

POST

Power-On Self Test

QDR

quad data rate

RBSU

ROM-Based Setup Utility

SAS

serial attached SCSI

SATA

serial ATA

SFF

small form factor

SFP

small form-factor pluggable

TPM

Trusted Platform Module

UID

unit identification

USB

universal serial bus

Documentation feedback

HP is committed to providing documentation that meets your needs. To help us improve the documentation, send any errors, suggestions, or comments to Documentation Feedback (<mailto:docsfeedback@hp.com>). Include the document title and part number, version number, or the URL when submitting your feedback.

Index

A

AC power supply 38, 113, 114
access panel 31
air baffle 32

B

battery 64, 66
buttons 95

C

cable management arm 28
cables 74
cabling 74
cautions 31
components 16, 95
components, identification 16, 95
connectors 95
CSR (customer self repair) 6, 16
customer self repair (CSR) 6, 16

D

diagnostic tools 88, 91
diagnostics utility 91
DIMM slot locations 105
DIMMs 63, 105
drive LEDs 108
drives 37, 108

E

electrostatic discharge 30
embedded UEFI diagnostics 90
environmental specifications 111
error messages 94
expansion board retainers 29
expansion boards 56, 57
expansion slot blanks 55
extending server from rack 27
external USB functionality 93

F

fan cage 42
fans 42, 109
features 95
FlexibleLOM 43
front panel buttons 97
front panel components 95
front panel LEDs 97
full-length expansion board 29

H

hard drive backplane 49
hard drive bays 95
hard drive blanks 37
hard drive cage 44
hard drive LEDs 108
hard drives, determining status of 108
health LEDs 97
heatsink 58
hot-plug fans 28, 109
HP Insight Diagnostics 91
HP technical support 6

I

illustrated parts catalog 16
iLO (Integrated Lights-Out) 92, 93
IML (Integrated Management Log) 93
Insight Diagnostics 91
Integrated Lights-Out (iLO) 93
Integrated Management Log (IML) 93
internal USB functionality 93

L

LEDs 100, 108
LEDs, front panel 108
LEDs, hard drive 108
LEDs, SAS hard drive 108
LEDs, troubleshooting 94

M

maintenance 26
management tools 88
mechanical components 16
mechanical specifications 111

O

optical drive 39, 95

P

part numbers 16
PCI expansion slots 102
PCIe riser blank 33
PCIe riser board 36
PCIe riser cage 34, 35
power supply blank 38
power supply LEDs 102
power supply specifications 113, 114
powering down 26
preparation procedures 26
problem diagnosis 94

R

rear panel components 101
rear panel LEDs 102
rear panel, accessing 28
removal and replacement procedures 26
removing server from rack 27

S

safety considerations 30
SAS and SATA device numbers 106
serial number 90
spare part numbers 16, 19
specifications 111
specifications, environmental 111
specifications, mechanical 111
specifications, power 113, 114
specifications, server 111
static electricity 30
symbols on equipment 30
system battery 66
system board components 103
system board replacement 67
system components 19, 95
system maintenance switch 104
system power LED 97
Systems Insight Display 28, 54, 100

Systems Insight Display LEDs 99, 100

T

technical support 6
tools 26
TPM (Trusted Platform Module) 73
troubleshooting 94

U

USB connector 95
USB support 93
utilities 88

V

video connector 95

W

warnings 31