

FB10000 Error Messages Troubleshooting

Error ID: 67004: Safety - Emergency stop pressed - Loader (REC side)

Error Severity: **Critical**

Possible Causes

- [The loader \(REC side\) emergency stop button was pressed](#)
- [E.S. button is faulty or cable CX161-03400 connecting the E.S. to the B&R module is disconnected](#)
- [Safety B&R module is faulty](#)

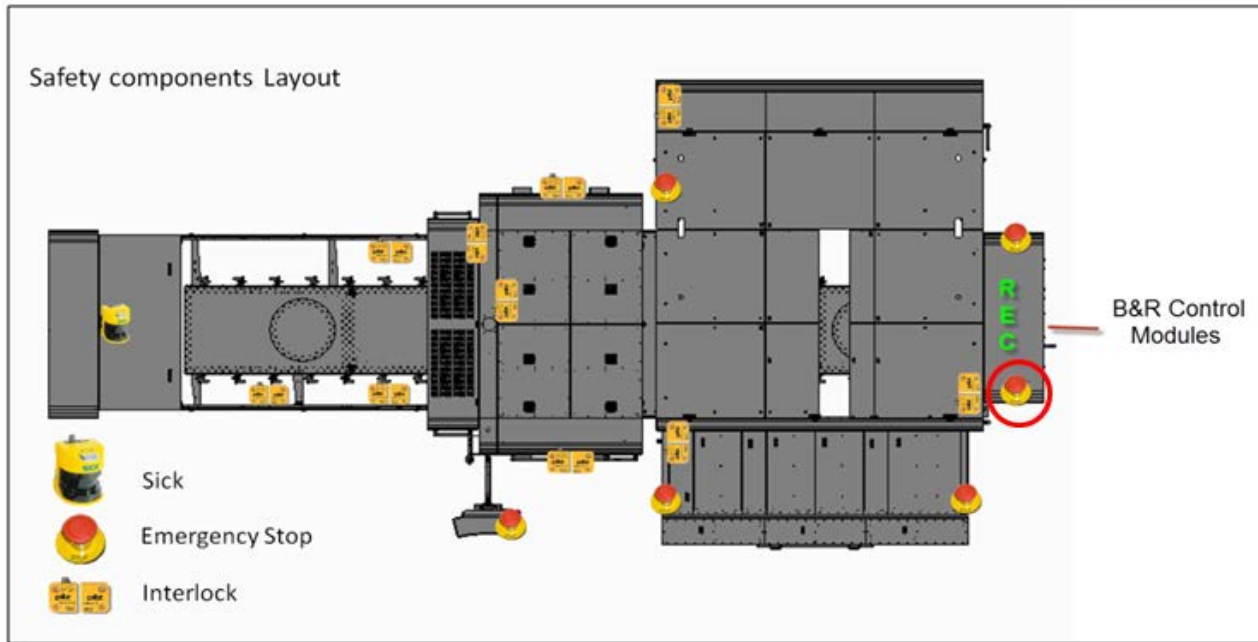

Troubleshooting Flowchart

Troubleshooting Flowchart

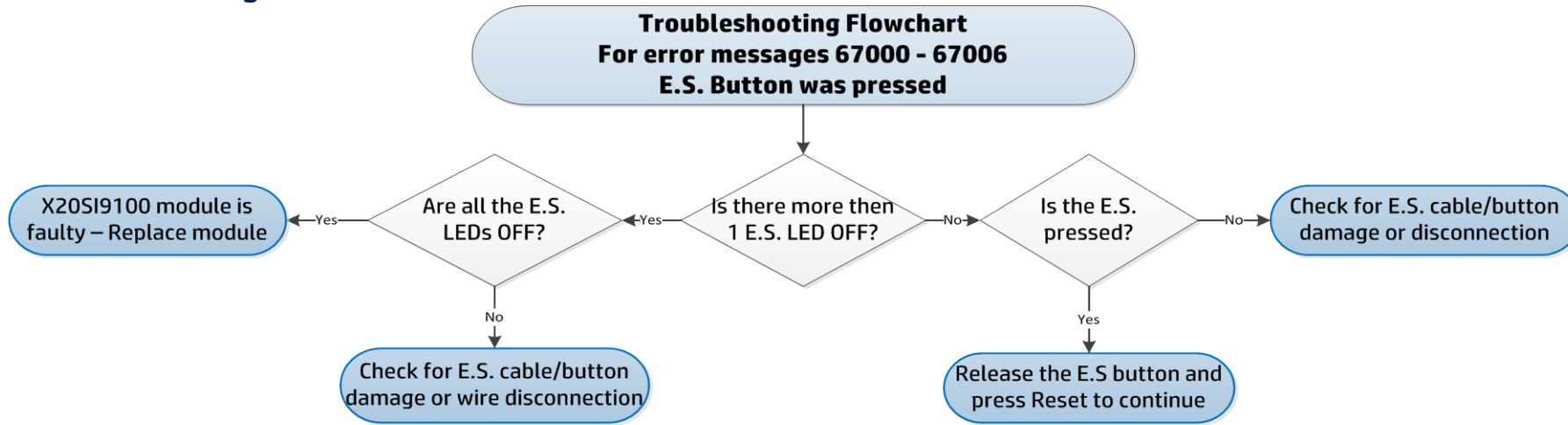

**2SD11 LEDs and Connections
E.S. Button Loader REC side**

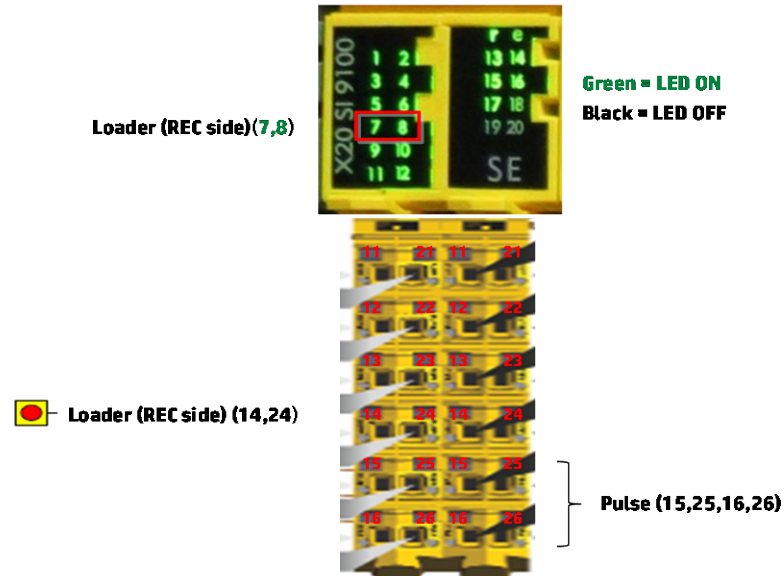

Recommended Actions

Loading table right emergency stop button is pressed

1. Release the Loader (REC side) emergency stop button.
2. Press the Reset (blue) button on the operator console.
3. Tap Get Ready to continue
4. If the error message persists, check wiring between the E.S. button and the 2SDI1 B&R module.

**WARNING! High Voltage System! Do not touch any wiring while system is UP!
From this stage and on, only an HP certified electrician may perform the tests.**

E.S. button is faulty or cable CX161-03400 connecting the E.S. to the B&R module is disconnected

5. Go to the REC cabinet and check LEDs SI 7 and SI 8 in the 2SDI1 B&R Safety Module.



Safety B&R PLC

Safety B&R module



In normal operation, both LEDs should be turned on (light green).

In case of error in one of the channels, the corresponding LED turns off.

In case of error in both channels, both LEDs turn off.

If all LEDs in the module are OFF, this indicates a connection problem between the B&R PLC and the X20SI910 B&R module.

6. If this is the case, check the connections between these two components and strengthen them as required.
7. Check the E.S. button and the cable connecting it to the Safety B&R module (in the REC).



8. Disconnect B&R 2SDI-SI 7(14) and 2TBM2(2) wires and check continuity between their ends:
9. When the E.S. button is the released position, you should get continuity between the two wires (normally closed).
10. Repeat steps 3 to 4 with the second couple of wires - B&R 2SDI-SI 8(24) and 2TBM4(2).

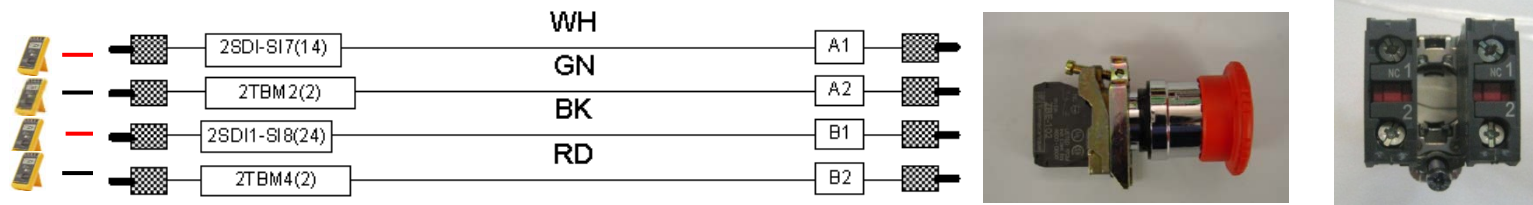

11. If both checks show continuity, this means that the cable and the button are ok.
12. If one of the checks shows no continuity, then we should check separately the E.S. button and the cable.
13. To check the E.S. button, disassemble it in a way its contacts are visible and set it to its Released position.
14. Use a DVM to check continuity between each couple of E.S. button poles [A1-A2 & B1-B2].
15. If there is continuity (normally closed) and the error persists, then the problem is not in the E.S. but in the cable.

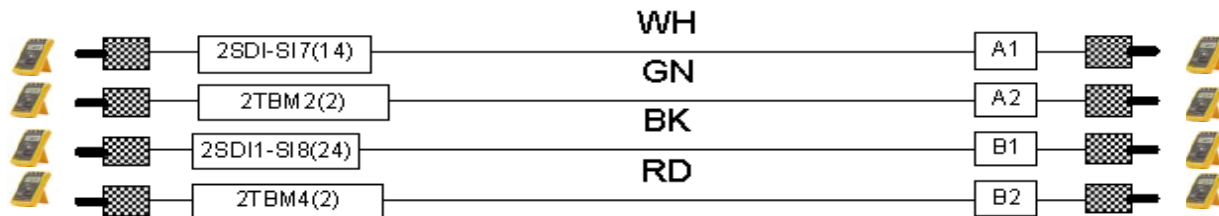

16. To check the cable between the E.S. button and the B&R Module, check end-to-end continuity of the four wires of the cable.
17. If the error persists, this might indicate that the B&R module itself is faulty.



Safety B&R Module is faulty

1. Turn the machine on.
2. Measure the voltage of the four wires via 24V_gnd (24V_0) as shown below, you should get 24V in all 4 wires.

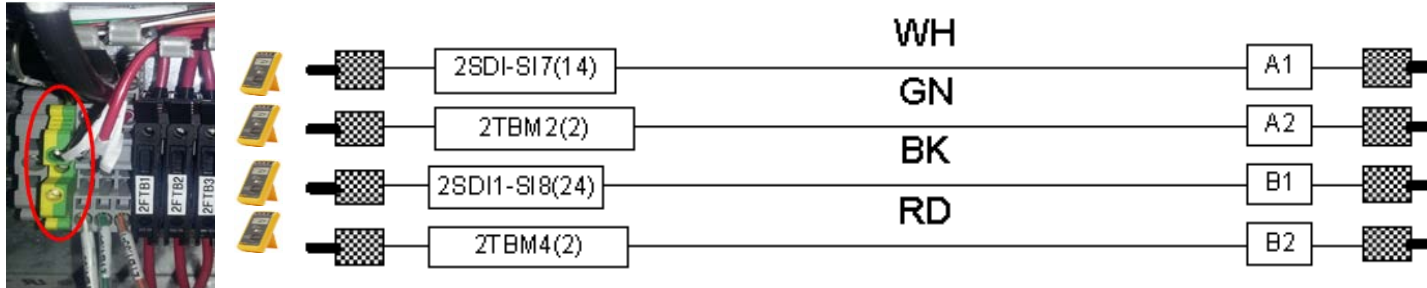

3. If the error persists, this means that the B&R module is faulty and should be replaced.

Note: Each B&R Safety module is comprised of three components: Base, BSU (Bus Supply Unit) module, and two (12 pins) Terminal blocks as shown below. Replacing a B&R module means replacing its BSU unit which is the “heart” of the module.

4. Before replacing a B&R module, turn the machine power OFF.
5. Release the two TBs from the faulty BSU module together with their wires, as shown in the figure below.
6. Pull the BSU out of the module base and replace it by a new BSU module.
7. Plug the two TBs back into the BSU module until you hear a click.
Upon turning on the machine, the R/E led will blink green once, signaling that it has detected the new module.

Step 1: Press the two latches (1) on top of the two TBs (2) and unplug them from the faulty BSU module.

Step 2: Press the two latches (5) on top of the BSU module (3) and unplug it from its base (4).

Step 3: Plug the new BSU module (3) into its base (4).

Step 4: Plug the two TBs (2) back into the BSU module (3) until you hear a click.

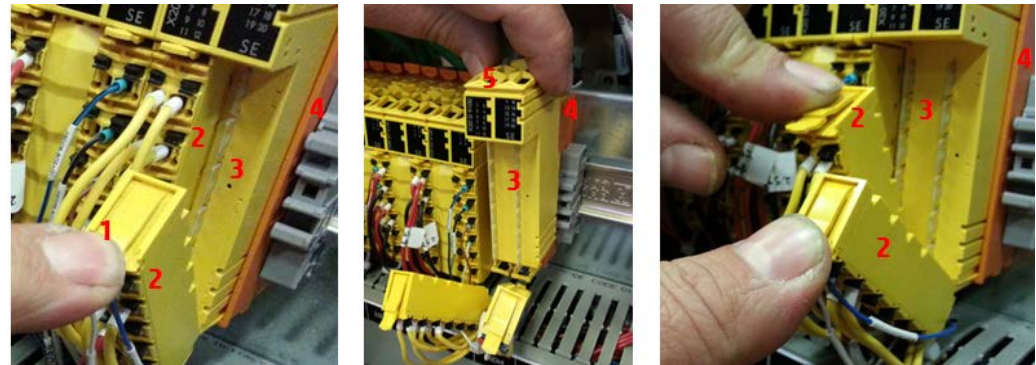

8. Turn the machine on and configure the B&R Safety PLC to recognize and set the new module(s) as described below.

Blinks green before configuring

Blinks orange once and turns off

Static lit "FAIL" LEDs = defective module that must be changed immediately

Set to 1 if one module was replaced

Press Enter to reset & configure the module

Constantly lit SE LED indicates a defective module that must be replaced immediately

9. Set the Safety PLC selector to 1 (one new module) and press the Enter button to instruct the Safety PLC to configure the new module. Upon completion, the MXCHG LED will blink orange once and then will turn off to confirm that the module was configured.

Note: This procedure takes up to two minutes. However, when the PLC encounters internal errors, it runs a full system scan and resets the entire system. This procedure takes between 40 to 60 minutes.

10. If the MXCHG LED continues blinking orange once every 5 seconds, this indicates that the PLC failed to configure the new module (in case of 2 replaced modules, it will blink twice every 5 seconds etc.). Check if you have set the scan selector according to the number of new modules.

Note: Interchanging two existing modules will be detected by the Safety PLC as two new modules.

11. If the MXCHG LED continues blinking orange once every 5 seconds, please consult the detailed [B&R PLC configuration guide](#), on page 4 for further instructions.
12. If the error persists, contact your HP regional specialist.
13. If none of the above steps solved the problem, contact your HP service specialist..

Note: The diagram in the next page gives an overview of the tested components and provides at the bottom, a legend of the B&R naming conventions.



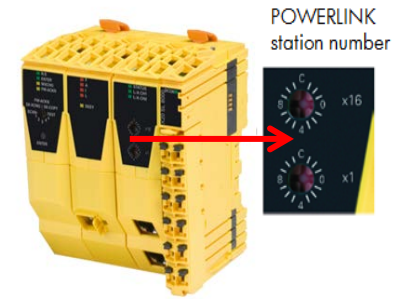
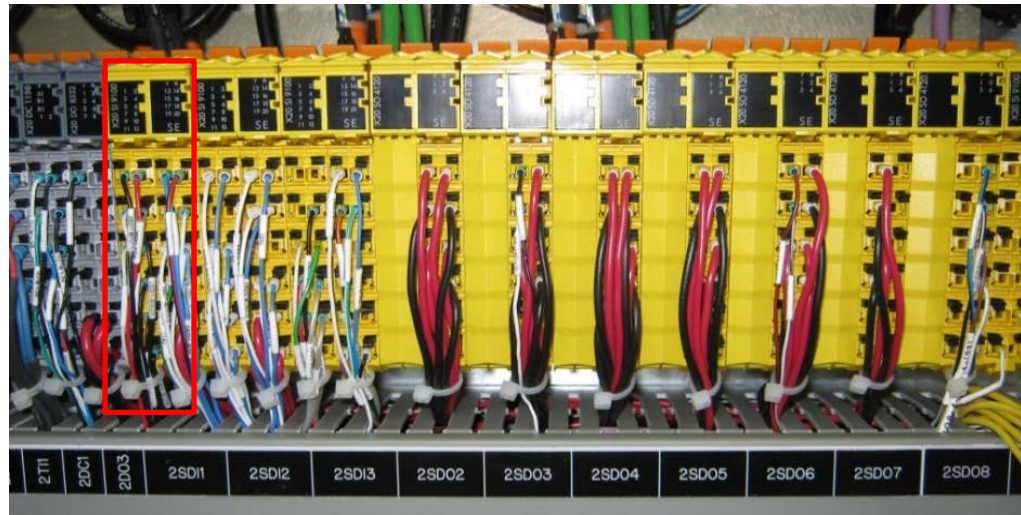
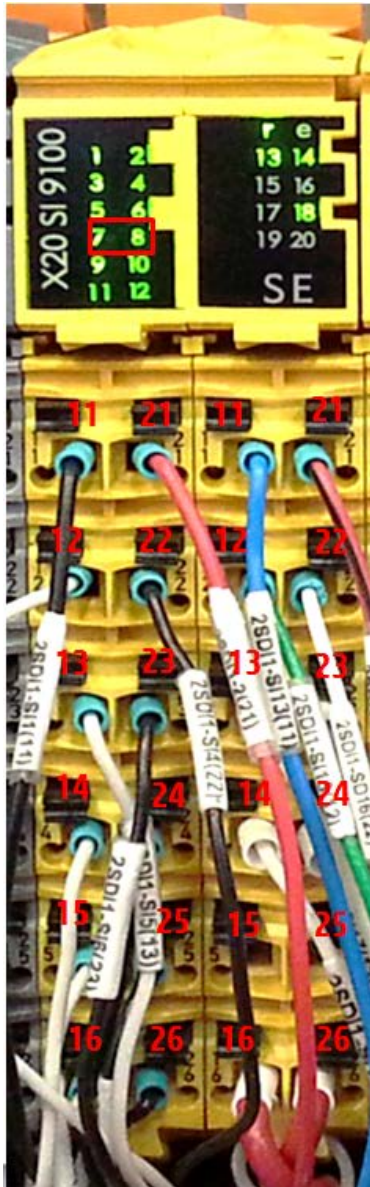

Note: The Safety PLC (Configuration link) is set as Station 6

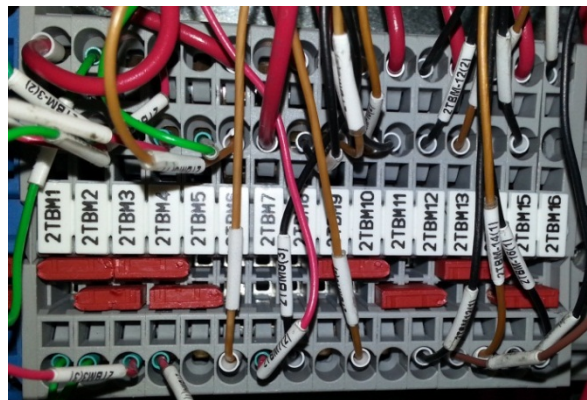
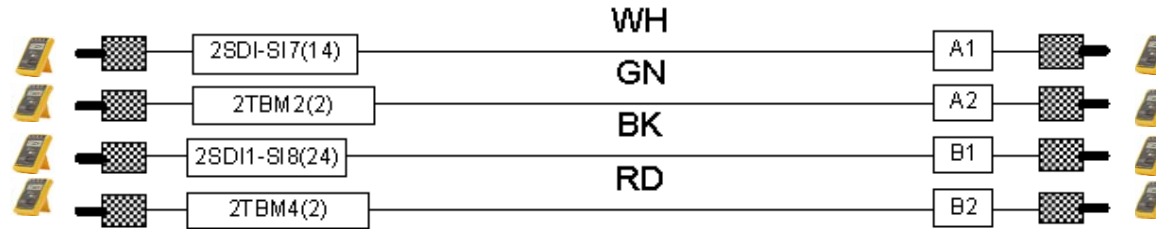

Location [2=REC]
 S = Safety
 I/O Type
 B&R Module # [pair]
 B&R LED #
 Terminal point

2 S DI 1 - SI 7 (14)

