



HP Notebook 14

Maintenance and Service Guide
IMPORTANT! This document is intended for
HP authorized service providers only.

© Copyright 2016 HP Development Company, L.P.

Bluetooth is a trademark owned by its proprietor and used by HP Inc. under license. Intel and Celeron are trademarks of Intel Corporation in the U.S. and other countries. Microsoft and Windows are either registered trademarks or trademarks of Microsoft Corporation in the United States and/or other countries.

Product notice

This guide describes features that are common to most models. Some features may not be available on your computer.

Not all features are available in all editions of Windows. This computer may require upgraded and/or separately purchased hardware, drivers and/or software to take full advantage of Windows functionality. Go to <http://www.microsoft.com> for details.

The information contained herein is subject to change without notice. The only warranties for HP products and services are set forth in the express warranty statements accompanying such products and services. Nothing herein should be construed as constituting an additional warranty. HP shall not be liable for technical or editorial errors or omissions contained herein.

First Edition: February 2015

Document Part Number: 855909-001

Important Notice

 **CAUTION:** This computer does not have user-replaceable parts. Your computer includes parts that should only be accessed by an authorized service provider. Accessing parts described in Chapter 5, "Removal and replacement procedures for authorized service provider parts," can damage the computer or void your warranty.

Safety warning notice

 **WARNING!** To reduce the possibility of heat-related injuries or of overheating the device, do not place the device directly on your lap or obstruct the device air vents. Use the device only on a hard, flat surface. Do not allow another hard surface, such as an adjoining optional printer, or a soft surface, such as pillows or rugs or clothing, to block airflow. Also, do not allow the AC adapter to contact the skin or a soft surface, such as pillows or rugs or clothing, during operation. The device and the AC adapter comply with the user-accessible surface temperature limits defined by the International Standard for Safety of Information Technology Equipment (IEC 60950-1).

Table of contents

1 Product description	1
2 External component identification	2
Right side (select products only)	2
Left side	2
Display	3
Front	4
Top	5
TouchPad	5
Lights	6
Buttons	7
Keys	8
Using the action keys	8
Locating system information	9
3 Illustrated parts catalog	10
Computer major components	10
Display assembly subcomponents	13
Miscellaneous parts	14
4 Removal and replacement procedures preliminary requirements	15
Tools required	15
Service considerations	15
Plastic parts	15
Cables and connectors	16
Drive handling	16
Grounding guidelines	17
Electrostatic discharge damage	17
Packaging and transporting guidelines	18
Workstation guidelines	18
Equipment guidelines	19
5 Removal and replacement procedures for authorized service provider parts	20
Component replacement procedures	20
Base enclosure	20
Battery	22

Optical drive dummy	22
Hard drive	23
Memory	25
WLAN module	28
Heat sink and fan	30
Speakers	32
Microphone	34
System board	36
WLAN cable	39
Display assembly	41
Webcam	45
6 Using Setup Utility (BIOS)	47
Starting Setup Utility (BIOS)	47
Updating Setup Utility (BIOS)	47
Determining the BIOS version	47
Downloading a BIOS update	48
7 Backing up, restoring, and recovering	49
Creating recovery media and backups	49
Creating HP Recovery media (select products only)	49
Using Windows tools	50
Restore and recovery	50
8 Using HP PC Hardware Diagnostics (UEFI)	51
Downloading HP PC Hardware Diagnostics (UEFI) to a USB device	51
9 Specifications	53
Computer specifications	53
35.56 cm (14-in) display specifications	54
Hard drive specifications	54
10 Power cord set requirements	56
Requirements for all countries	56
Requirements for specific countries and regions	56
11 Recycling	58
Index	59

1 Product description

Category	Description
Product Name	HP Notebook 14
Processors	<ul style="list-style-type: none">• Intel® Celeron® Processor 3215U• Fifth generation Intel® Core™ i3-5005U
Panel	14" HD LCD, 16:9 LED type, resolution 1366 x 768
Memory	SODIMM 4 GB PC3L 12800 (maximum 8 GB)
Hard drive	SATA 500 GB 5400 RPM 7mm
Optical drive dummy	Dummy, ODD Bezel, ODD
Audio and video	<ul style="list-style-type: none">• Audio-out (headphone)/Audio-in (microphone) combo jack• Internal microphone• HDMI port
Ethernet	RJ-45 network jack
Wireless	Wireless LAN —IEEE802.11 b/g/n support Wireless LAN+ Bluetooth (select products only)—IEEE802.11 b/g/n support, BT 4.0, USB interface
Ports	<ul style="list-style-type: none">• 2 x USB2.0• 1 x USB3.0
External media cards	Supports optional SD/MS/MS Pro memory cards
Power requirements	19.5 V dc @ 2.31 A – 45 W
Security	Security cable slot (select products only)
Operating system	Windows 10 64-bit
Serviceability	End user replaceable parts: <ul style="list-style-type: none">• AC adapter• Power cord

2 External component identification

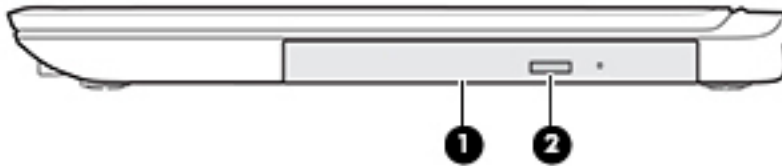

Right side (select products only)



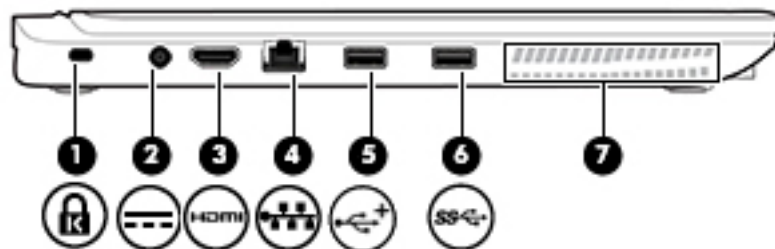

Component	Description
(1) Optical drive (select products only)	Depending on your computer, reads an optical disc or reads and writes to an optical disc. NOTE: For disc compatibility information, type <code>help</code> in the taskbar search box, select Help and Support , and then type <code>disc compatibility</code> in the search box.
(2) Optical drive eject button (select products only)	Releases the optical drive disc tray.

Left side



Component	Description
(1) Security cable slot	Attaches an optional security cable to the computer. NOTE: The security cable is designed to act as a deterrent, but it may not prevent the computer from being mishandled or stolen.
(2) Power connector	Connects an AC adapter.
(3)  HDMI port	Connects an optional video or audio device, such as a high-definition television, any compatible digital or audio component, or a high-speed High-Definition Multimedia Interface (HDMI) device.
(4)  RJ-45 (network) jack/status lights	Connects a network cable. <ul style="list-style-type: none">• White: The network is connected.• Amber: Activity is occurring on the network.

Component	Description
(5)  USB 2.0 port	Connects an optional USB device, such as a keyboard, mouse, external drive, printer, scanner or USB hub.
(6)  USB 3.0 port	Connects an optional USB device, such as a keyboard, mouse, external drive, printer, scanner or USB hub.
(7) Vent	Enables airflow to cool internal components. NOTE: The computer fan starts up automatically to cool internal components and prevent overheating. It is normal for the internal fan to cycle on and off during routine operation.

Display

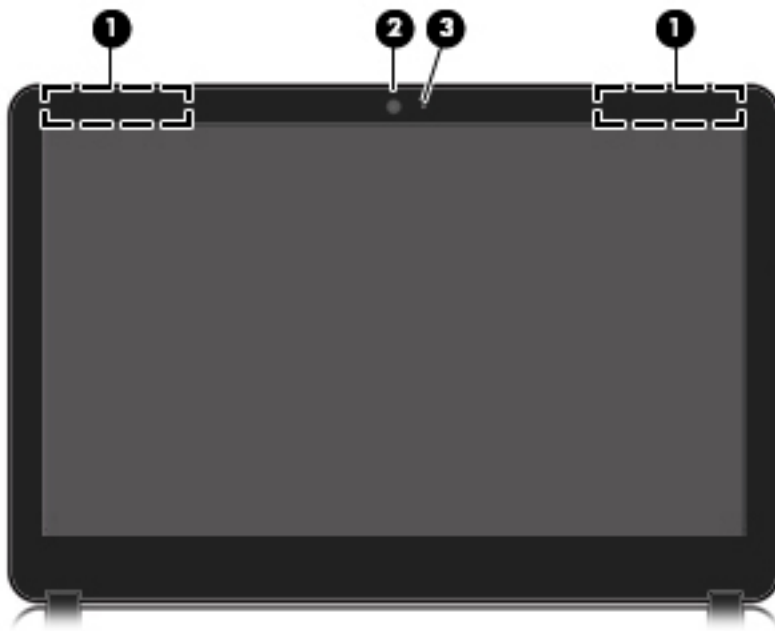

Component	Description
(1) WLAN antennas (2)*	Send and receive wireless signals to communicate with wireless local area networks (WLANs).
(2) Webcam	Records video and captures photographs. Some products allow you to video conference and chat online using streaming video. To use a webcam (integrated camera): ▲ Type camera in the taskbar search box, and then select Camera .
(3) Webcam light	On: The webcam is in use.

*The antennas are not visible from the outside of the computer. For optimal transmission, keep the areas immediately around the antenna free from obstructions.



For wireless regulatory notices, see the section of the *Regulatory, Safety, and Environmental Notices* that applies to your country or region.

To access this guide:

Component	Description
▲	Select the Start button, select All apps , select HP Help and Support , and then select HP Documentation .

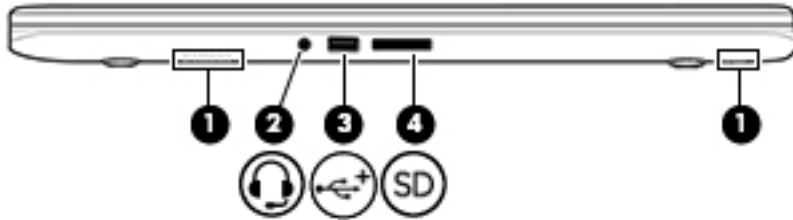
Front



Component	Description	
(1)	Speakers (2)	Produce sound.
(2) 	Audio-out (headphone)/Audio-in (microphone) combo jack	<p>Connects optional powered stereo speakers, headphones, earbuds, a headset, or a television audio cable. Also connects an optional headset microphone. This jack does not support optional standalone microphones.</p> <p>WARNING! To reduce the risk of personal injury, adjust the volume before putting on headphones, earbuds, or a headset. For additional safety information, refer to the <i>Regulatory, Safety, and Environmental Notices</i>.</p> <p>To access this guide:</p> <p>▲ Select the Start button, select All apps, select HP Help and Support, and then select HP Documentation.</p> <p>NOTE: When a device is connected to the jack, the computer speakers are disabled.</p>
(3) 	USB 2.0 port	Connects an optional USB device, such as a keyboard, mouse, external drive, printer, scanner or USB hub.
(4) 	Memory card reader	<p>Reads optional memory cards that enable you to store, manage, share, or access information.</p> <p>To insert a card:</p> <ol style="list-style-type: none"> 1. Hold the card label-side up, with connectors facing the computer. 2. Insert the card into the memory card reader, and then press in on the card until it is firmly seated. <p>To remove a card:</p> <p>▲ Press in on the card, and then remove it from the memory card reader.</p>

Top

TouchPad

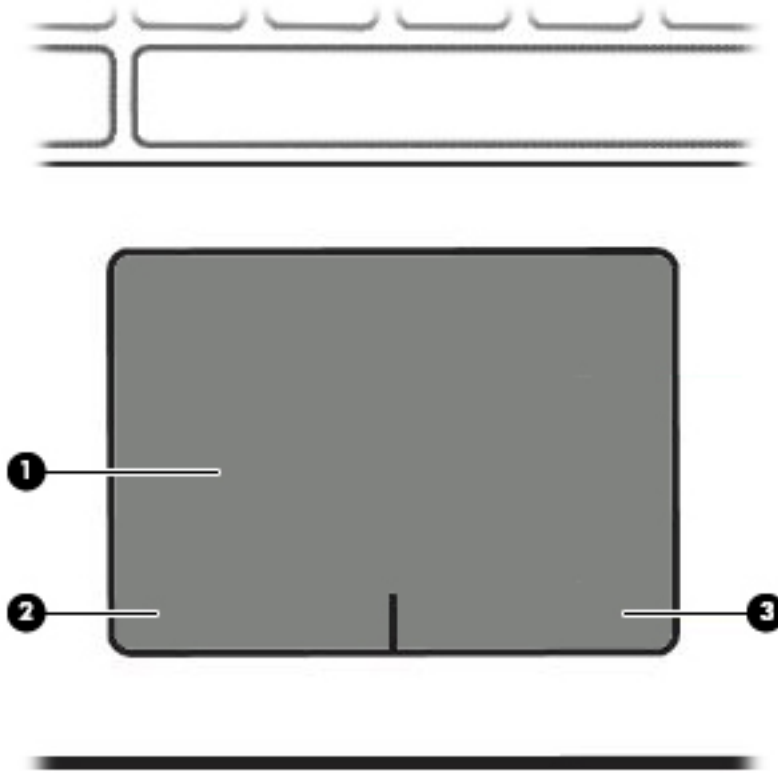

Component	Description
(1) TouchPad zone	Reads your finger gestures to move the pointer or activate items on the screen.
(2) Left TouchPad button	Functions like the left button on an external mouse.
(3) Right TouchPad button	Functions like the right button on an external mouse.

Lights

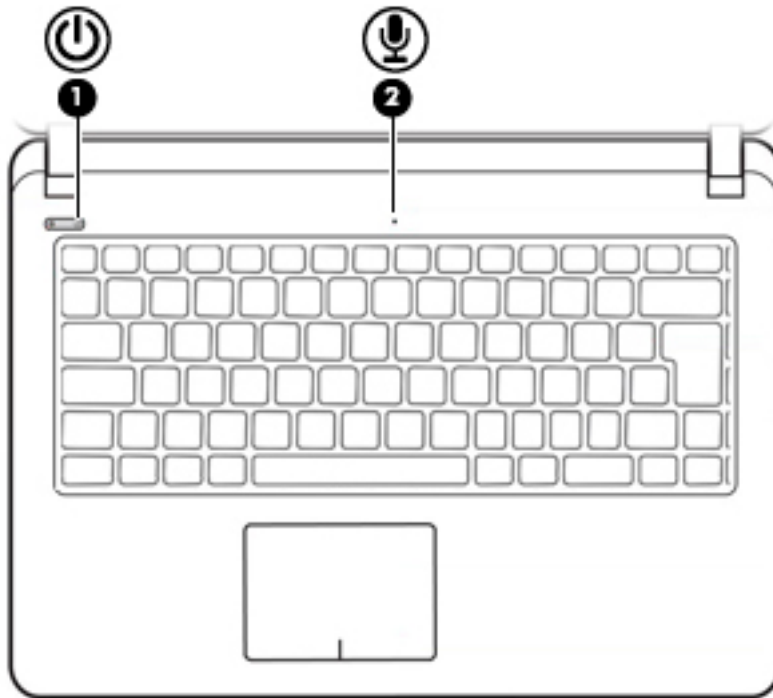

Component	Description
(1)  Power light	<ul style="list-style-type: none">• On: The computer is on.• Blinking: The computer is in the Sleep state, a power-saving state. The computer shuts off power to the display and other unneeded components.• Off: The computer is off or in Hibernation. Hibernation is a power-saving state that uses the least amount of power.
(2) Internal microphone	Records sound.

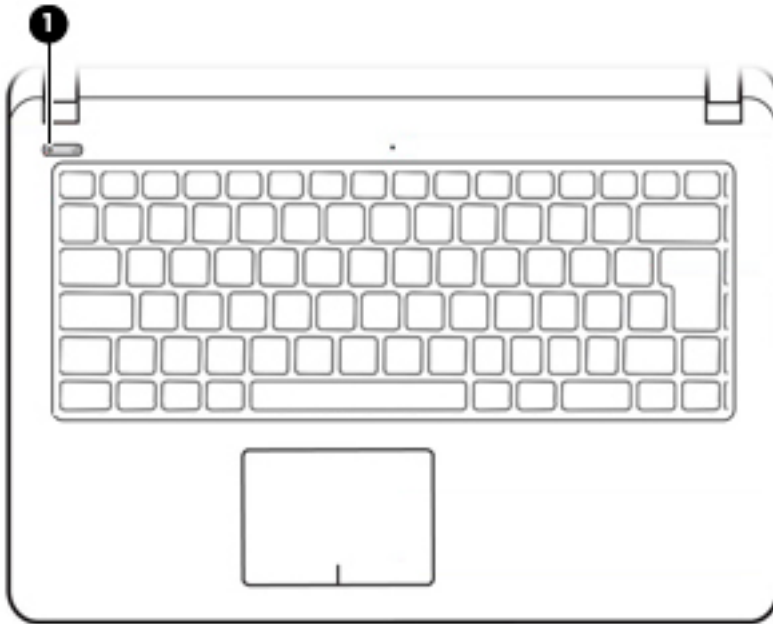

Buttons



Component	Description
(1)  Power button	<ul style="list-style-type: none">• When the computer is off, press the button to turn on the computer.• When the computer is on, press the button briefly to initiate Sleep.• When the computer is in the Sleep state, press the button briefly to exit Sleep.• When the computer is in Hibernation, press the button briefly to exit Hibernation. <p>CAUTION: Pressing and holding down the power button results in the loss of unsaved information.</p> <p>If the computer has stopped responding and shutdown procedures are ineffective, press and hold the power button down for at least 5 seconds to turn off the computer.</p> <p>To learn more about your power settings, see your power options.</p> <p>▲ Type <code>power</code> in the taskbar search box, and then select Power and sleep settings.</p> <p>– or –</p> <p>Right-click the Start button, and then select Power Options.</p>

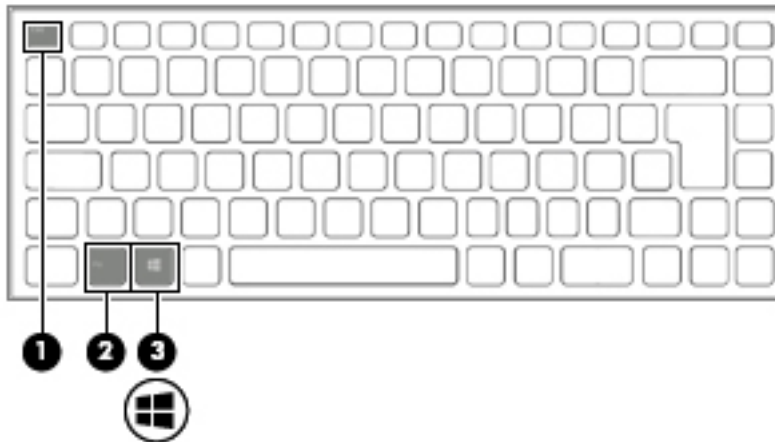

Keys







Component	Description
(1)  esc key	Executes frequently used system functions when pressed in combination with the fn key.
(2)  fn key	Executes frequently used system functions when pressed in combination with the esc key, action keys, or the spacebar .
(3)  Windows key	Opens the Start menu. NOTE: Pressing the Windows key again will close the Start menu.

Using the action keys

- An action key performs an assigned function.
- The icon on each action key illustrates the function for that key.
- To use an action key, press and hold the key.

Function key	Icon	Description
f1		Suspend
f2		Power saving
f3		Display switch
f4		Radio on/off
f5		On-screen display
f6		TouchPad on/off
f7		Webcam on/off
f8		Mutes or restores speaker sound.

Function key	Icon	Description
f9		Decreases speaker volume incrementally while you hold down the key.
f10		Increases speaker volume incrementally while you hold down the key.
f11		Decreases the screen brightness incrementally as long as you hold down the key.
f12		Increases the screen brightness incrementally as long as you hold down the key.

Locating system information

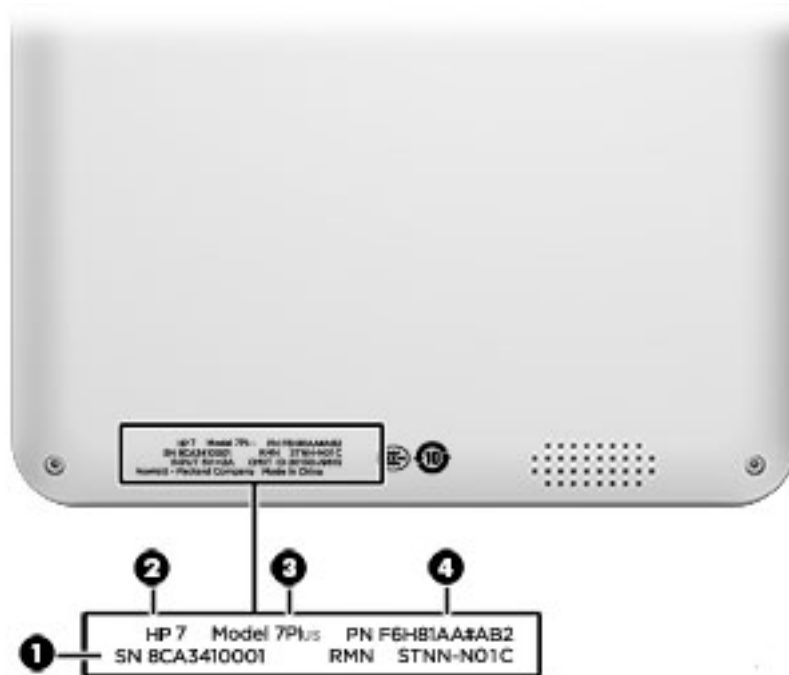

Important system information is located on the back of the computer. You may need the information when travelling internationally or when you contact support:

- (1):** Serial number
- (2):** Product number
- (3):** Model number
- (4):** Warranty period



3 Illustrated parts catalog

Computer major components

-
-  **NOTE:** HP continually improves and changes product parts. For complete and current information on supported parts for your computer, go to <http://partsurfer.hp.com>, select your country or region, and then follow the on-screen instructions.
 -  **NOTE:** Details about your computer, including model, serial number, product key, and length of warranty, are on the service tag at the bottom of your computer. See [Locating system information on page 9](#) for details.

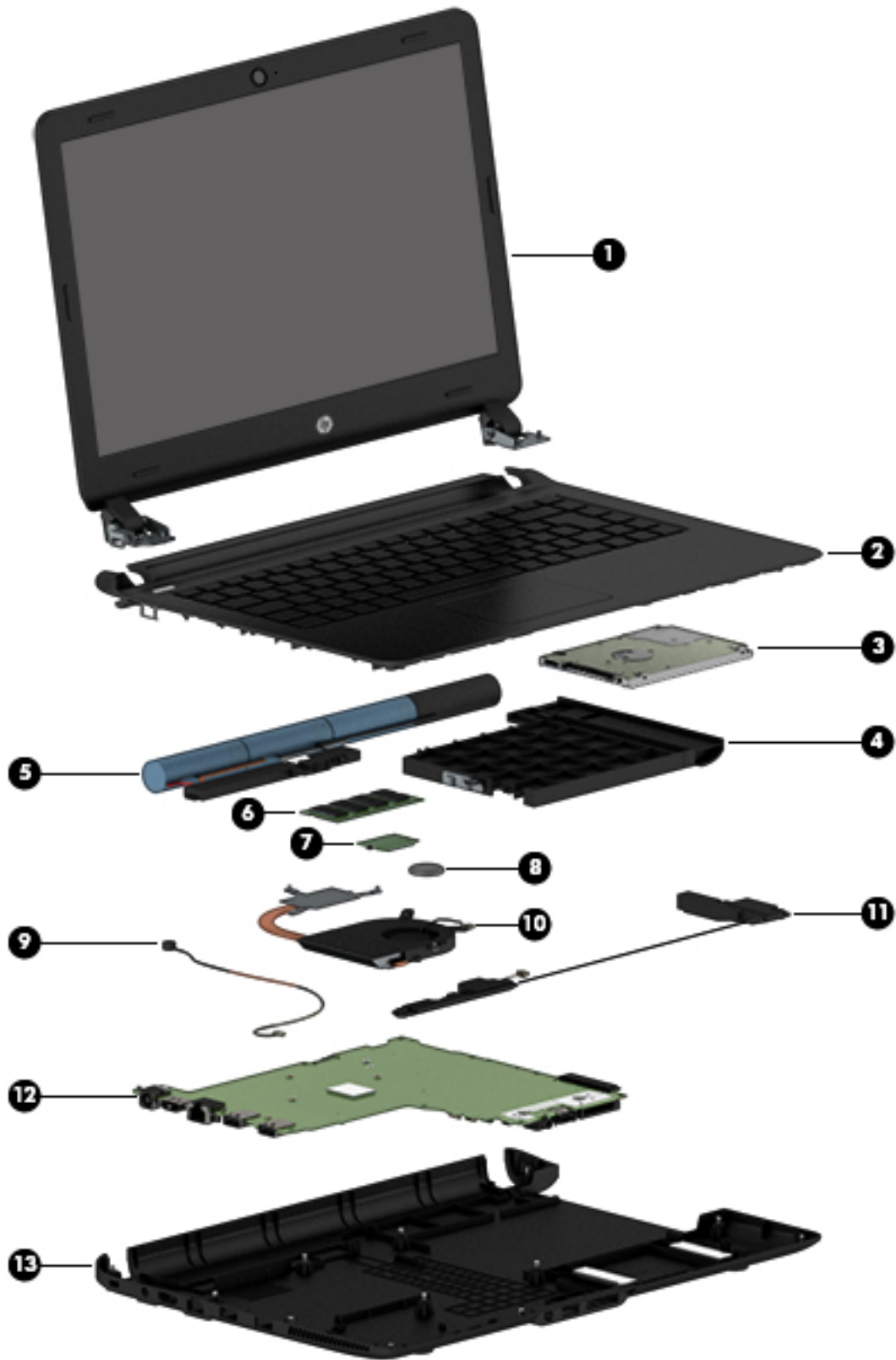

Item	Component	Spare part number
(1)	Display assembly (see Display assembly subcomponents on page 13)	

Item	Component	Spare part number
(2)	Top cover (includes keyboard and TouchPad)	854457-001
(3)	Hard drive (see Hard drive on page 23)	683839-855
(4)	Optical drive dummy (see Optical drive dummy on page 22)	854470-001
(5)	Battery (see Battery on page 22)	854472-001
(6)	Memory (see Memory on page 25)	691799-855
(7)	WLAN module (see WLAN module on page 28)	792505-855
(8)	RTC battery	855483-001
(9)	Webcam (see Webcam on page 45)	854509-001
(10)	Fan (see Heat sink and fan on page 30)	854468-001
	Heat sink (see Heat sink and fan on page 30)	854469-001
(11)	Speaker (see Speakers on page 32)	854475-001
(12)	System board (see System board on page 36)	854479-001
(13)	Base enclosure	854473-001

Display assembly subcomponents

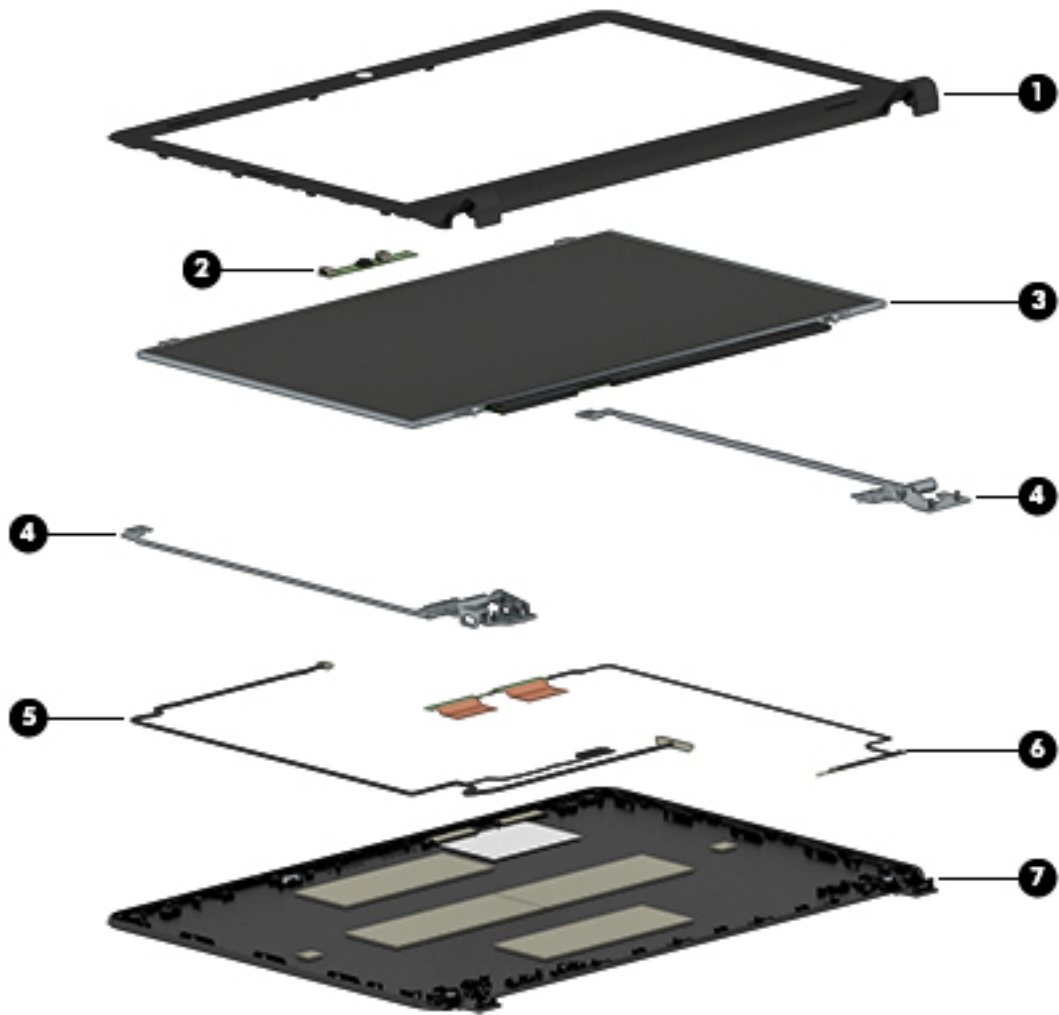

Item	Component	Spare part number
(1)	Display bezel	854447-001
(2)	Microphone (see Microphone on page 34)	854474-001
(3)	Panel	854448-001
(4)	Hinge kit	854508-001
(5)	WLAN antennas	854450-001 854451-001
(6)	WLAN cable	792505-855
(7)	Back cover	854507-001
	Not shown:	
	Display cable	854449-001
	Touch panel cable (select products only)	854477-001

Miscellaneous parts

Component	Spare part number
AC adapter	741553-851
DC connector	854443-001
Middle frame	854476-001
Power cord	438722-004
Screw kit	854511-001
RTC battery	855483-001

4 Removal and replacement procedures preliminary requirements

Tools required

You will need the following tools to complete the removal and replacement procedures:

- Flat-bladed screwdriver
- Magnetic screwdriver
- Phillips P0 and P1 screwdrivers

Service considerations

The following sections include some of the considerations that you must keep in mind during disassembly and assembly procedures.

 **NOTE:** As you remove each subassembly from the computer, place the subassembly (and all accompanying screws) away from the work area to prevent damage.

Plastic parts

 **CAUTION:** Using excessive force during disassembly and reassembly can damage plastic parts. Use care when handling the plastic

Cables and connectors

⚠ CAUTION: When servicing the computer, be sure that cables are placed in their proper locations during the reassembly process. Improper cable placement can damage the computer.

Cables must be handled with extreme care to avoid damage. Apply only the tension required to unseat or seat the cables during removal and insertion. Handle cables by the connector whenever possible. In all cases, avoid bending, twisting, or tearing cables. Be sure that cables are routed in such a way that they cannot be caught or snagged by parts being removed or replaced. Handle flex cables with extreme care; these cables tear easily.

Drive handling

⚠ CAUTION: Drives are fragile components that must be handled with care. To prevent damage to the computer, damage to a drive, or loss of information, observe these precautions:

Before removing or inserting a hard drive, shut down the computer. If you are unsure whether the computer is off or in Hibernation, turn the computer on, and then shut it down through the operating system.

Before handling a drive, be sure that you are discharged of static electricity. While handling a drive, avoid touching the connector.

Before removing an optical drive, be sure that a disc is not in the drive and be sure that the optical drive tray is closed.

Handle drives on surfaces covered with at least one inch of shock-proof foam.

Avoid dropping drives from any height onto any surface.

After removing a hard drive or an optical drive, place it in a static-proof bag.

Avoid exposing an internal hard drive to products that have magnetic fields, such as monitors or speakers.

Avoid exposing a drive to temperature extremes or liquids.

If a drive must be mailed, place the drive in a bubble pack mailer or other suitable form of protective packaging and label the package "FRAGILE."

Grounding guidelines

Electrostatic discharge damage

Electronic components are sensitive to electrostatic discharge (ESD). Circuitry design and structure determine the degree of sensitivity. Networks built into many integrated circuits provide some protection, but in many cases, ESD contains enough power to alter device parameters or melt silicon junctions.

A discharge of static electricity from a finger or other conductor can destroy static-sensitive devices or microcircuitry. Even if the spark is neither felt nor heard, damage may have occurred.

An electronic device exposed to ESD may not be affected at all and can work perfectly throughout a normal cycle. Or the device may function normally for a while, then degrade in the internal layers, reducing its life expectancy.

CAUTION: To prevent damage to the computer when you are removing or installing internal components, observe these precautions:

Keep components in their electrostatic-safe containers until you are ready to install them.

Before touching an electronic component, discharge static electricity by using the guidelines described in this section.

Avoid touching pins, leads, and circuitry. Handle electronic components as little as possible.

If you remove a component, place it in an electrostatic-safe container.

The following table shows how humidity affects the electrostatic voltage levels generated by different activities.

CAUTION: A product can be degraded by as little as 700 V.

Typical electrostatic voltage levels			
Event	Relative humidity		
	10%	40%	55%
Walking across carpet	35,000 V	15,000 V	7,500 V
Walking across vinyl floor	12,000 V	5,000 V	3,000 V
Motions of bench worker	6,000 V	800 V	400 V
Removing DIPS from plastic tube	2,000 V	700 V	400 V
Removing DIPS from vinyl tray	11,500 V	4,000 V	2,000 V
Removing DIPS from plastic foam	14,500 V	5,000 V	3,500 V
Removing bubble pack from PCB	26,500 V	20,000 V	7,000 V
Packing PCBs in foam-lined box	21,000 V	11,000 V	5,000 V

Packaging and transporting guidelines

Follow these grounding guidelines when packaging and transporting equipment:

- To avoid hand contact, transport products in static-safe tubes, bags, or boxes.
- Protect ESD-sensitive parts and assemblies with conductive or approved containers or packaging.
- Keep ESD-sensitive parts in their containers until the parts arrive at static-free workstations.
- Place items on a grounded surface before removing items from their containers.
- Always be properly grounded when touching a component or assembly.
- Store reusable ESD-sensitive parts from assemblies in protective packaging or nonconductive foam.
- Use transporters and conveyors made of antistatic belts and roller bushings. Be sure that mechanized equipment used for moving materials is wired to ground and that proper materials are selected to avoid static charging. When grounding is not possible, use an ionizer to dissipate electric charges.

Workstation guidelines

Follow these grounding workstation guidelines:

- Cover the workstation with approved static-shielding material.
- Use a wrist strap connected to a properly grounded work surface and use properly grounded tools and equipment.
- Use conductive field service tools, such as cutters, screwdrivers, and vacuums.
- When fixtures must directly contact dissipative surfaces, use fixtures made only of static safe materials.
- Keep the work area free of nonconductive materials, such as ordinary plastic assembly aids and plastic foam.
- Handle ESD-sensitive components, parts, and assemblies by the case or PCM laminate. Handle these items only at static-free workstations.
- Avoid contact with pins, leads, or circuitry.
- Turn off power and input signals before inserting or removing connectors or test equipment.

Equipment guidelines

Grounding equipment must include either a wrist strap or a foot strap at a grounded workstation.

- When seated, wear a wrist strap connected to a grounded system. Wrist straps are flexible straps with a minimum of one megohm $\pm 10\%$ resistance in the ground cords. To provide proper ground, wear a strap snugly against the skin at all times. On grounded mats with banana-plug connectors, use alligator clips to connect a wrist strap.
- When standing, use foot straps and a grounded floor mat. Foot straps (heel, toe, or boot straps) can be used at standing workstations and are compatible with most types of shoes or boots. On conductive floors or dissipative floor mats, use foot straps on both feet with a minimum of one megohm resistance between the operator and ground. To be effective, the conductive equipment must be worn in contact with the skin.

The following grounding equipment is recommended to prevent electrostatic damage:

- Antistatic tape
- Antistatic smocks, aprons, and sleeve protectors
- Conductive bins and other assembly or soldering aids
- Nonconductive foam
- Conductive tabletop workstations with ground cords of one megohm resistance
- Static-dissipative tables or floor mats with hard ties to the ground
- Field service kits
- Static awareness labels
- Material-handling packages
- Nonconductive plastic bags, tubes, or boxes
- Metal tote boxes
- Electrostatic voltage levels and protective materials

The following table lists the shielding protection provided by antistatic bags and floor mats.

Material	Use	Voltage protection level
Antistatic plastics	Bags	1,500 V
Carbon-loaded plastic	Floor mats	7,500 V
Metallized laminate	Floor mats	5,000 V

5 Removal and replacement procedures for authorized service provider parts

CAUTION: Components described in this chapter should be accessed only by an authorized service provider. Accessing these parts can damage the computer or void the warranty.

CAUTION: This computer does not have user-replaceable parts. Only HP authorized service providers should perform the removal and replacement procedures described here. Accessing the internal part could damage the computer or void the warranty.

Component replacement procedures

NOTE: Details about your computer, including model, serial number, product key, and length of warranty, are on the service tag at the bottom of your computer. See [Locating system information on page 9](#) for details.

NOTE: HP continually improves and changes product parts. For complete and current information on supported parts for your computer, go to <http://partsurfer.hp.com>, select your country or region, and then follow the on-screen instructions.

There are as many as xx screws that must be removed, replaced, and/or loosened when servicing the parts described in this chapter. Make special note of each screw size and location during removal and replacement.

Base enclosure

Description	Spare part number
Base enclosure	854473-001

Before disassembling the computer, follow these steps:

1. Turn off the computer. If you are unsure whether the computer is off or in Hibernation, turn the computer on, and then shut it down through the operating system.
2. Disconnect the power from the computer by unplugging the power cord from the computer.
3. Disconnect all external devices from the computer.

Remove the base enclosure:

1. Position the computer upside down on a flat surface.
2. Remove 13 screws **(1)**.
3. Slide a nylon flake tool around the edge of the base enclosure **(2)** to loosen it, taking care not to damage the internal clips.

4. Press lightly on the base enclosure with both hands to release the headphone jack before removing the base enclosure (3).

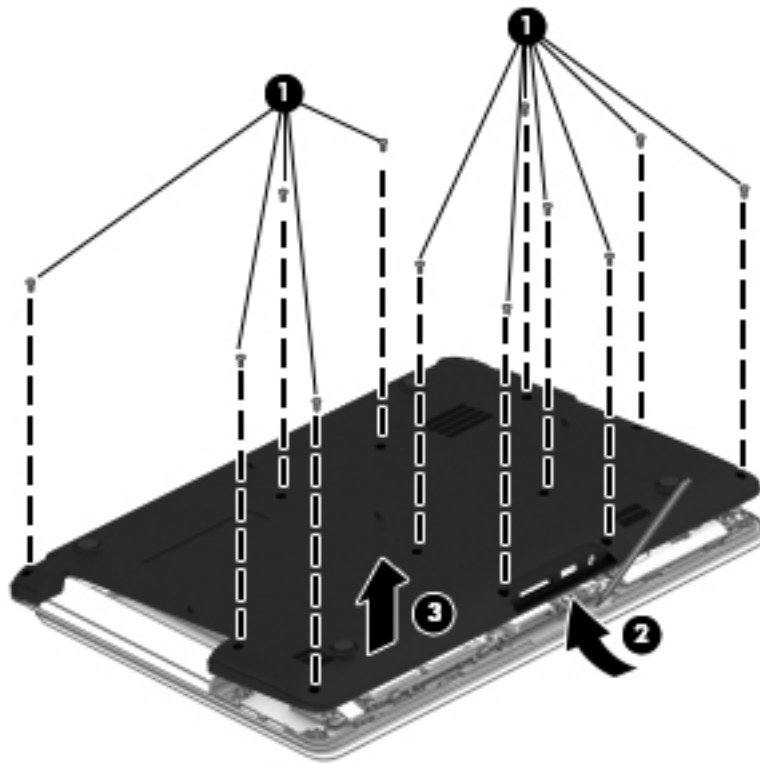

Battery

Description	Spare part number
Battery LI-ION, 23.76 Wh, 00, N/A	854472-001

Remove the battery:

- WARNING!** To reduce potential safety issues, use only the user-replaceable battery provided with the computer, a replacement battery provided by HP, or a compatible battery purchased from HP.
- CAUTION:** Removing a user-replaceable battery that is the sole power source for the computer can cause loss of information. To prevent loss of information, save your work or shut down the computer through Windows before removing the battery.

1. Position the computer upside down on a flat surface.
2. Carefully remove the battery to avoid damaging the connection.

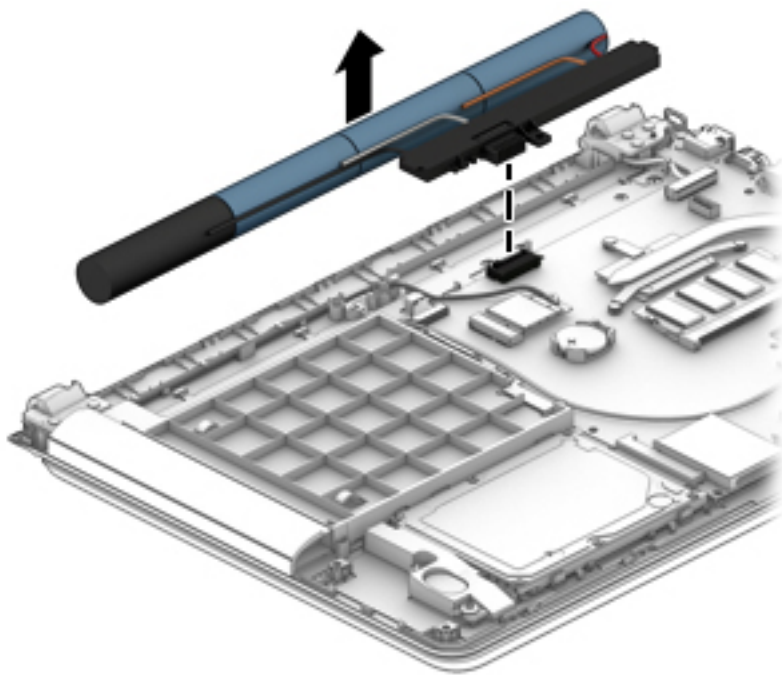

To insert the battery, reverse the removal procedures.

Optical drive dummy

Description	Spare part number
Optical drive dummy	854470-001
Optical drive bezel	854471-001

- IMPORTANT:** Make special note of each screw and screw lock size and location during removal and replacement.

Before removing the optical drive dummy, follow these steps:

1. Shut down the computer.
2. Disconnect all external devices connected to the computer.
3. Disconnect the power from the computer by first unplugging the power cord from the AC outlet and then unplugging the AC adapter from the computer.
4. Remove the base enclosure (see [Base enclosure on page 20](#)), and then remove the following components:
 - ▲ Battery (see [Battery on page 22](#)).

Remove the optical drive dummy:

- ▲ Remove 1 screw **(1)**, and then remove the optical drive dummy **(2)**.

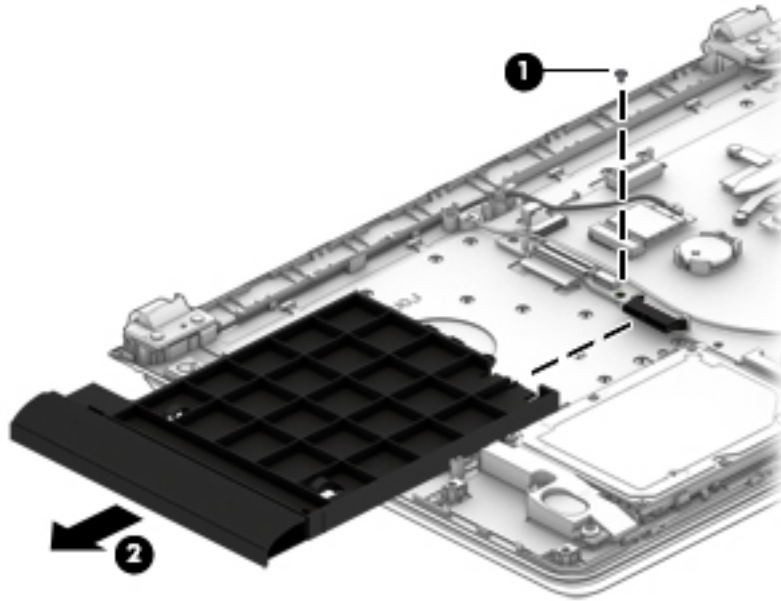

Reverse this procedure to install the optical drive dummy.

Hard drive

Description	Spare part number
Hard drive, SATA 500 GB 5400 RPM 7MM	683839-855

 **IMPORTANT:** Make special note of each screw and screw lock size and location during removal and replacement.

Before removing the hard drive, follow these steps:

1. Shut down the computer.
2. Disconnect all external devices connected to the computer.

3. Disconnect the power from the computer by first unplugging the power cord from the AC outlet and then unplugging the AC adapter from the computer.
4. Remove the base enclosure (see [Base enclosure on page 20](#)), and then remove the following components:
 - a. Battery (see [Battery on page 22](#)).
 - b. Optical drive dummy (see [Optical drive dummy on page 22](#)).

Remove the hard drive:

- ▲ Gently pull the hard drive horizontally **(1)**, and then remove it **(2)**.

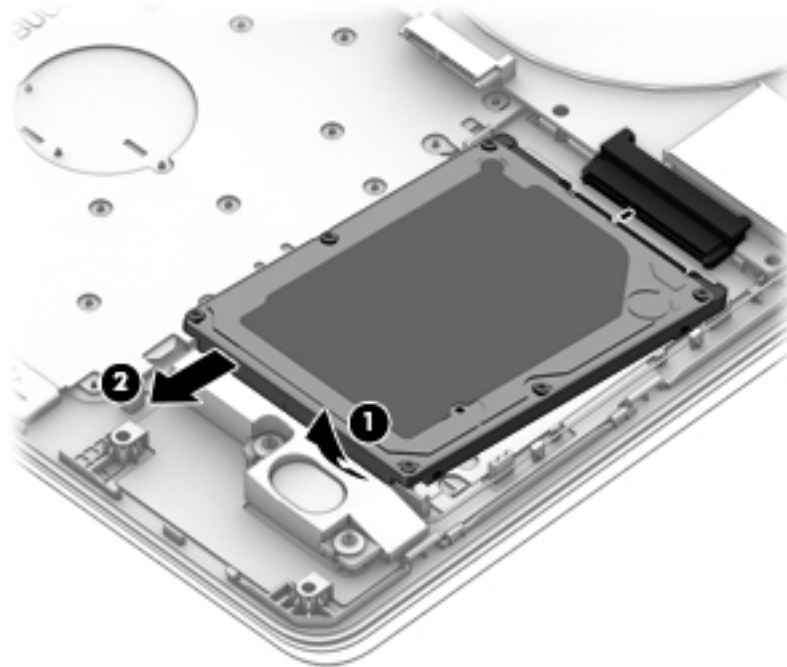

Reverse this procedure to install the hard drive.

Memory

Description	Spare part number
Memory—SODIMM 4GB PC3L 12800 (maximum 8 GB)	691799-855

 **IMPORTANT:** Make special note of each screw and screw lock size and location during removal and replacement.

Before removing the memory, follow these steps:

1. Shut down the computer.
2. Disconnect all external devices connected to the computer.
3. Disconnect the power from the computer by first unplugging the power cord from the AC outlet and then unplugging the AC adapter from the computer.
4. Remove the base enclosure (see [Base enclosure on page 20](#)), and then remove the following components:
 - a. Battery (see [Battery on page 22](#)).
 - b. Optical drive dummy (see [Optical drive dummy on page 22](#)).
 - c. Hard drive (see [Hard drive on page 23](#)).

If you are replacing a memory module, remove the existing memory module:

1. Lift the clear film covering the memory module.
2. Pull away the retention clips (**1**) on each side of the memory module.
The memory module tilts up.

3. Grasp the edge of the memory module (**2**), and then gently pull the memory module out of the memory module slot.

CAUTION: To prevent damage to the memory module, hold the memory module by the edges only. Do not touch the components on the memory module.

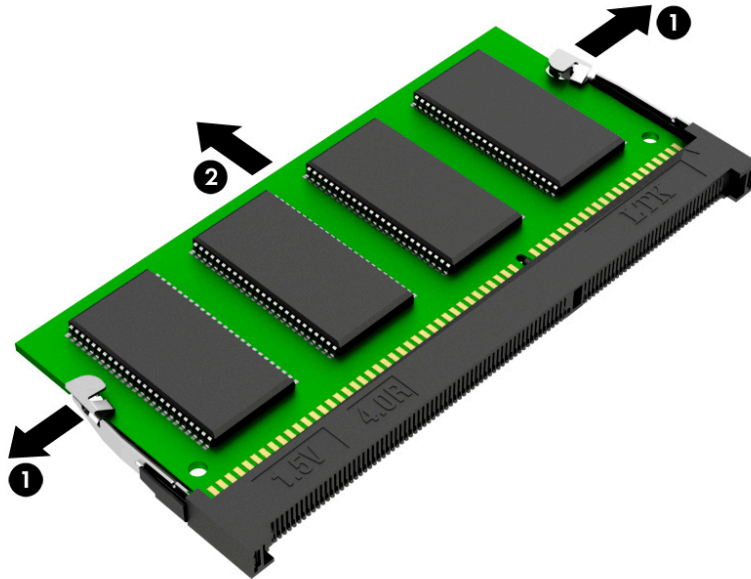

To protect a memory module after removal, place it in an electrostatic-safe container.

To install a memory module:

CAUTION: To prevent damage to the memory module, hold the memory module by the edges only. Do not touch the components on the memory module.

1. Align the notched edge (**1**) of the memory module with the tab in the memory module slot.

2. With the memory module at a 45-degree angle from the surface of the memory module compartment (2), press the module into the memory module slot until it is seated.

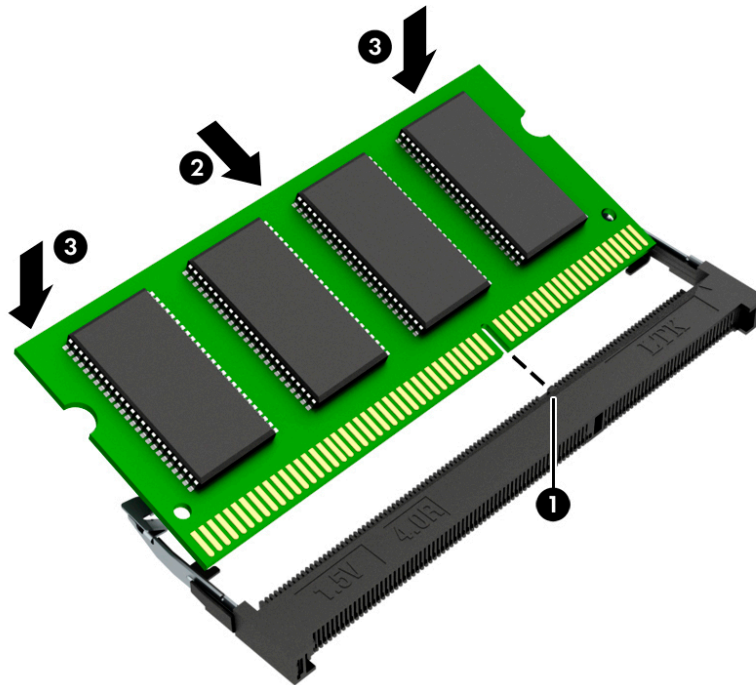

3. Gently press the memory module down (3), applying pressure to both the left and right edges of the memory module, until the retention clips snap into place.

⚠ CAUTION: To prevent damage to the memory module, be sure that you do not bend the memory module.

WLAN module

Description	Spare part number
WLAN RT 802.11 b/g/n +Bluetooth 4.0 1x1 SANJI	792505-855



IMPORTANT: Make special note of each screw and screw lock size and location during removal and replacement.

Before removing the WLAN module, follow these steps:

1. Shut down the computer.
2. Disconnect all external devices connected to the computer.
3. Disconnect the power from the computer by first unplugging the power cord from the AC outlet and then unplugging the AC adapter from the computer.
4. Remove the base enclosure (see [Base enclosure on page 20](#)), and then remove the following components:
 - a. Battery (see [Battery on page 22](#)).
 - b. Optical drive dummy (see [Optical drive dummy on page 22](#)).
 - c. Hard drive (see [Hard drive on page 23](#)).
 - d. Memory (see [Memory on page 25](#)).

Remove the WLAN module:

1. Carefully disconnect 2 antenna cables **(1)**.

2. Remove 1 Phillips screw **(2)**, and then remove the WLAN module **(3)**.

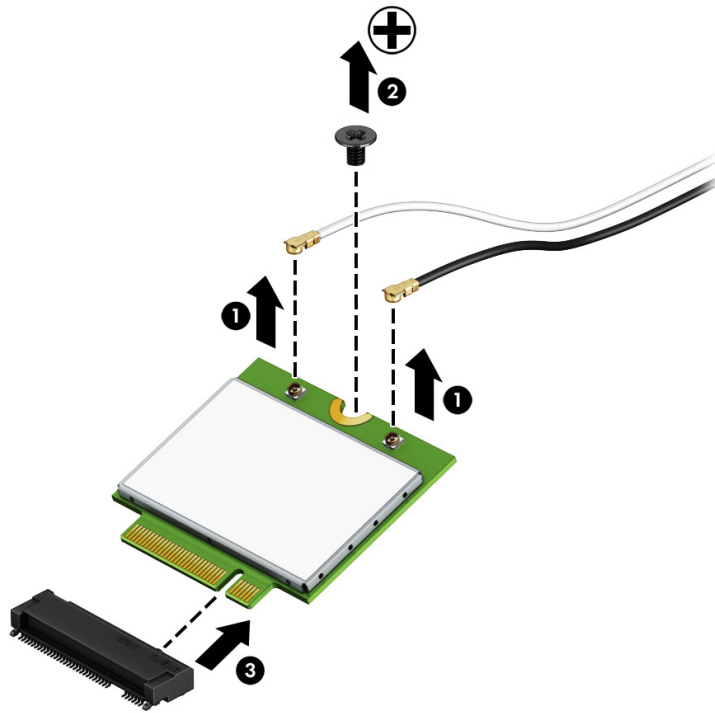

Reverse this procedure to install the WLAN module.

Heat sink and fan

Description	Spare part number
Fan	854468-001
Heat sink	854469-001



IMPORTANT: Make special note of each screw and screw lock size and location during removal and replacement.

Before removing the heat sink and the fan, follow these steps:

1. Shut down the computer.
2. Disconnect all external devices connected to the computer.
3. Disconnect the power from the computer by first unplugging the power cord from the AC outlet and then unplugging the AC adapter from the computer.
4. Remove the base enclosure (see [Base enclosure on page 20](#)), and then remove the following components:
 - a. Battery (see [Battery on page 22](#)).
 - b. Optical drive dummy (see [Optical drive dummy on page 22](#)).
 - c. Hard drive (see [Hard drive on page 23](#)).
 - d. Memory (see [Memory on page 25](#)).
 - e. WLAN module (see [WLAN module on page 28](#)).

Remove the heat sink and the fan:

1. Disconnect the heat sink connector from the system board **(1)**, and then loosen the cables from the routing channels.
2. Remove 3 screws from the heat sink**(2)**, and then loosen 3 captive screws from the fan **(3)**.

3. Lift to remove the heat sink and fan assembly(4).

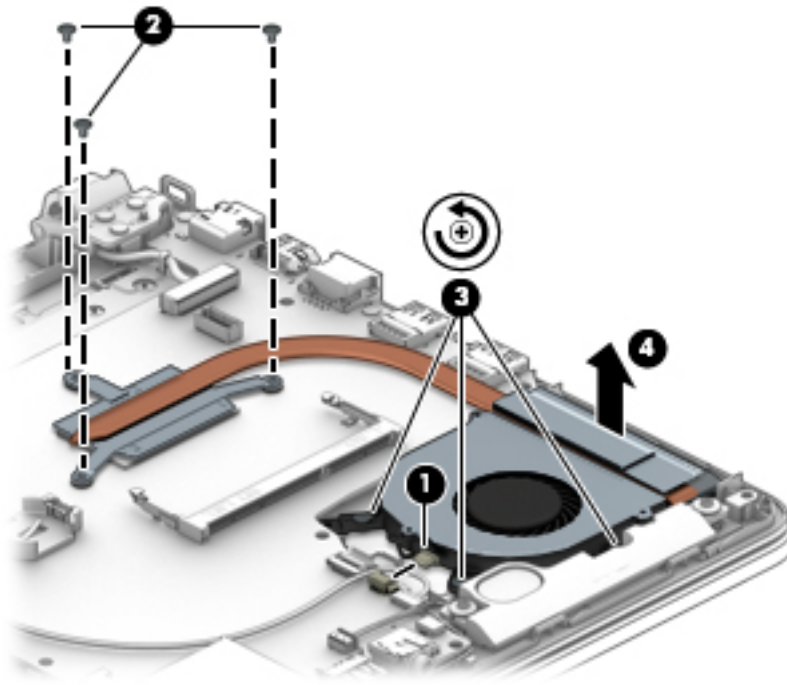

Reverse this procedure to install the heat sink and the fan.

Speakers

 **NOTE:** The speaker spare part kit includes the cable.

Description	Spare part number
Speaker Kit	854475-001

 **IMPORTANT:** Make special note of each screw and screw lock size and location during removal and replacement.

Before removing the speaker, follow these steps:

1. Shut down the computer.
2. Disconnect all external devices connected to the computer.
3. Disconnect the power from the computer by first unplugging the power cord from the AC outlet and then unplugging the AC adapter from the computer.
4. Remove the base enclosure (see [Base enclosure on page 20](#)), and then remove the following components:
 - a. Battery (see [Battery on page 22](#)).
 - b. Optical drive dummy (see [Optical drive dummy on page 22](#)).
 - c. Hard drive (see [Hard drive on page 23](#)).
 - d. Memory (see [Memory on page 25](#)).
 - e. WLAN module (see [WLAN module on page 28](#)).
 - f. Heat sink and fan (see [Heat sink and fan on page 30](#)).

Remove the speakers:

1. Disconnect the connector from the system board **(1)**.
2. Release the speaker cable from the routing channels **(2)**.

3. Lift the left speaker and the right speaker (3) to remove them.

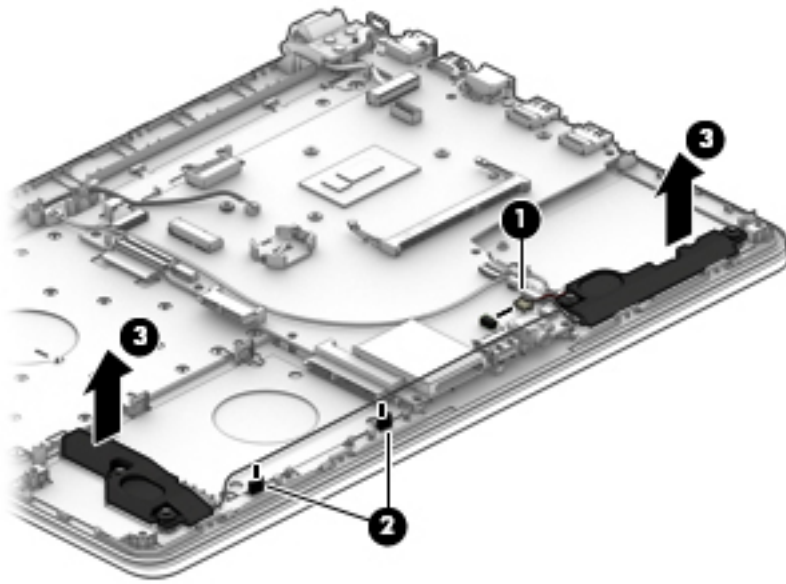

Reverse this procedure to install the speakers.

Microphone

Description	Spare part number
Microphone	854474-001



IMPORTANT: Make special note of each screw and screw lock size and location during removal and replacement.

Before removing the microphone, follow these steps:

1. Shut down the computer.
2. Disconnect all external devices connected to the computer.
3. Disconnect the power from the computer by first unplugging the power cord from the AC outlet and then unplugging the AC adapter from the computer.
4. Remove the base enclosure (see [Base enclosure on page 20](#)), and then remove the following components:
 - a. Battery (see [Battery on page 22](#)).
 - b. Optical drive dummy (see [Optical drive dummy on page 22](#)).
 - c. Hard drive (see [Hard drive on page 23](#)).
 - d. Memory (see [Memory on page 25](#)).
 - e. WLAN module (see [WLAN module on page 28](#)).
 - f. Heat sink and fan (see [Heat sink and fan on page 30](#)).
 - g. Speakers (see [Speakers on page 32](#)).

Remove the microphone:

1. Remove 4 strips of tape from the microphone cable, and then disconnect the microphone connector from the system board **(1)**.

2. Pull the microphone up carefully to avoid breaking the cable **(2)**, and then remove it **(3)**.

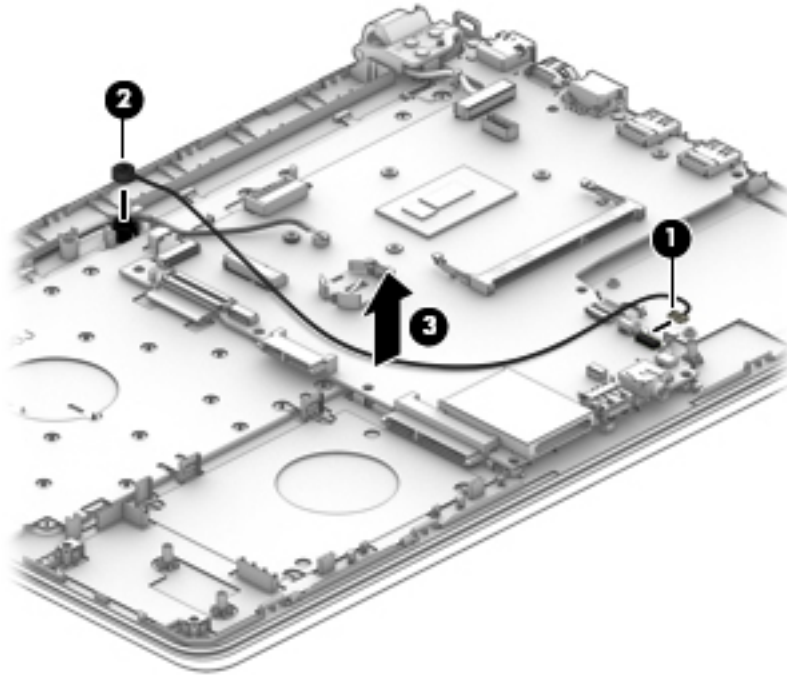

Reverse this procedure to install the microphone.

System board

Description	Spare part number
System board	
Intel system board i3-5005U	854479-001
Intel system board Celeron 3215U	854480-001



IMPORTANT: Make special note of each screw and screw lock size and location during removal and replacement.

Before removing the system board, follow these steps:

1. Shut down the computer.
2. Disconnect all external devices connected to the computer.
3. Disconnect the power from the computer by first unplugging the power cord from the AC outlet and then unplugging the AC adapter from the computer.
4. Remove the base enclosure (see [Base enclosure on page 20](#)), and then remove the following components:
 - a. Battery (see [Battery on page 22](#)).
 - b. Optical drive dummy (see [Optical drive dummy on page 22](#)).
 - c. Hard drive (see [Hard drive on page 23](#)).
 - d. Memory (see [Memory on page 25](#)).
 - e. WLAN module (see [WLAN module on page 28](#)).
 - f. Heat sink and fan (see [Heat sink and fan on page 30](#)).
 - g. Speakers (see [Speakers on page 32](#)).
 - h. Microphone (see [Microphone on page 34](#)).

Remove the system board:

1. Open the keyboard cable zero-insertion force (ZIF) connector **(1)**, and then release it from the system board **(2)**.

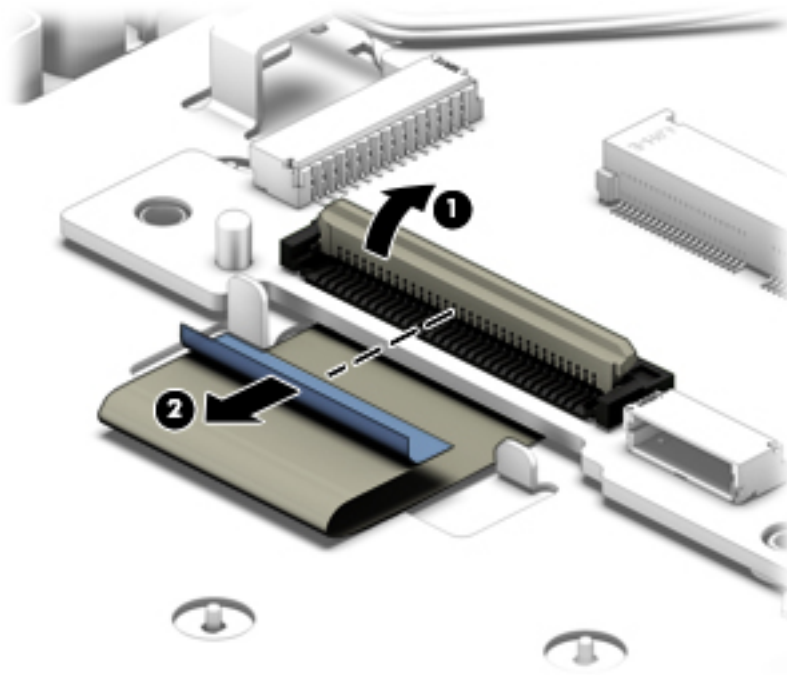

2. Open the display cable zero-insertion force (ZIF) connector **(1)**, and then release it from the system board **(2)**.

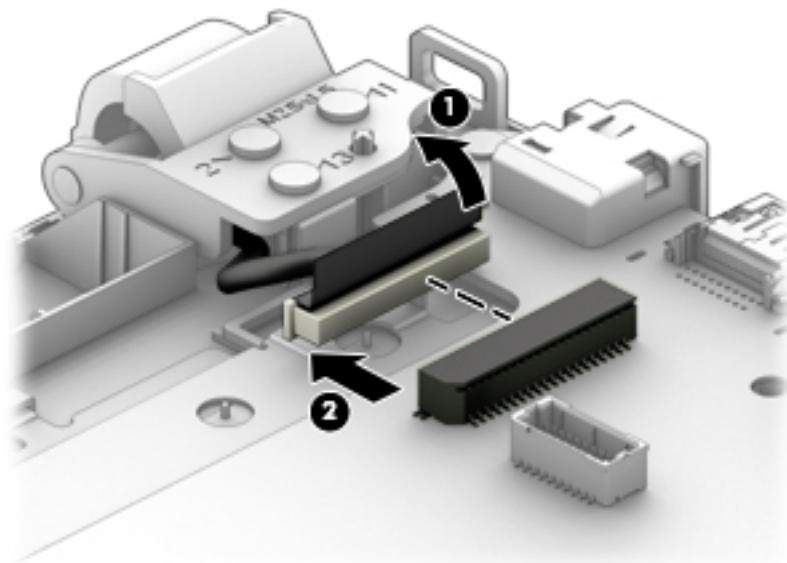

3. Open the TouchPad cable zero-insertion force (ZIF) connector **(1)**, and then disconnect it from the system board **(2)**.

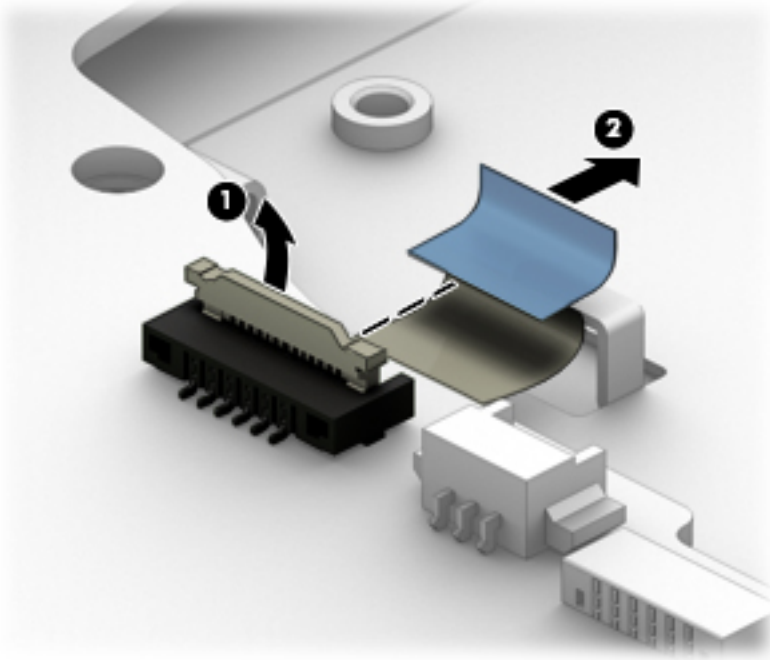

4. Remove 2 Phillips screws **(1)**.
5. Lift the system board **(2)**, and then remove it **(3)**.

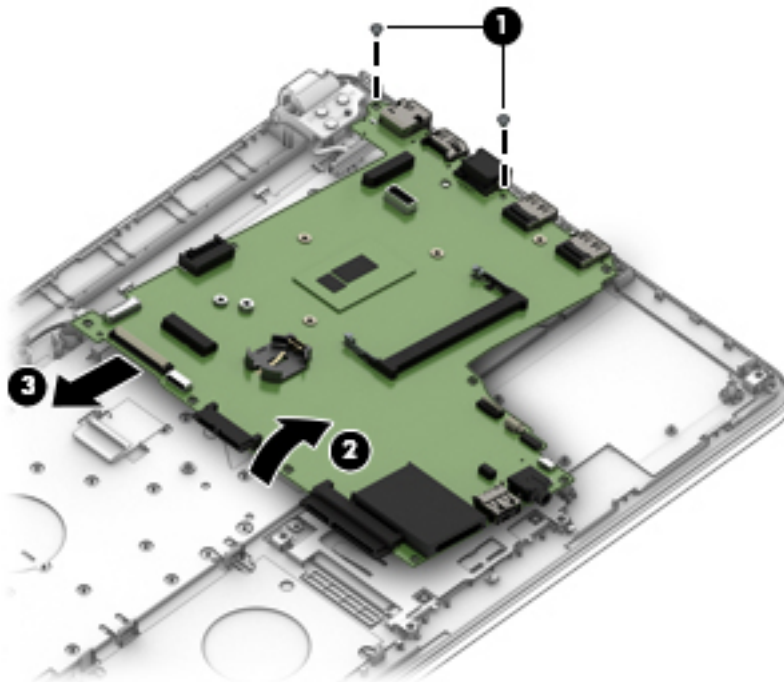

Reverse this procedure to install the system board.

WLAN cable

Description	Spare part number
WLAN cable	792505-855

 **IMPORTANT:** Make special note of each screw and screw lock size and location during removal and replacement.

Before removing the WLAN cable, follow these steps:

1. Shut down the computer.
2. Disconnect all external devices connected to the computer.
3. Disconnect the power from the computer by first unplugging the power cord from the AC outlet and then unplugging the AC adapter from the computer.
4. Remove the base enclosure (see [Base enclosure on page 20](#)), and then remove the following components:
 - a. Battery (see [Battery on page 22](#)).
 - b. Optical drive dummy (see [Optical drive dummy on page 22](#)).
 - c. Hard drive (see [Hard drive on page 23](#)).
 - d. Memory (see [Memory on page 25](#)).
 - e. WLAN module (see [WLAN module on page 28](#)).
 - f. Heat sink and fan (see [Heat sink and fan on page 30](#)).
 - g. Speakers (see [Speakers on page 32](#)).
 - h. Microphone (see [Microphone on page 34](#)).
 - i. System board (see [System board on page 36](#)).

Remove the WLAN cable:

- ▲ Disconnect the WLAN antenna from the WLAN module **(1)**, release the WLAN cable from the tape securing it **(2)**, and then lift the cable to remove it **(3)**.

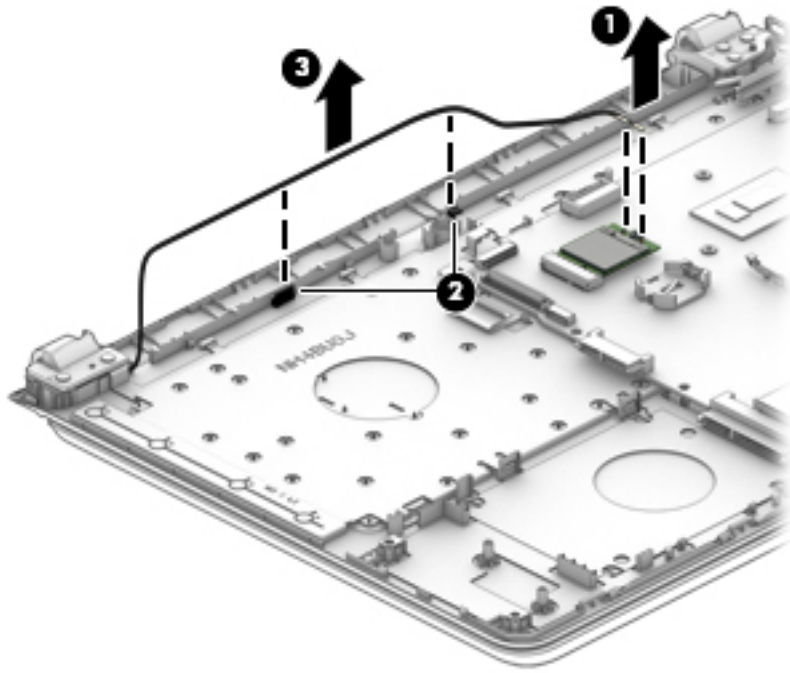

Reverse this procedure to install the WLAN cable.

Display assembly

Description	Spare part number
Bezel	854447-001
Panel	854448-001
Display cable	854449-001
Touch panel cable (select products only)	854477-001
Hinge kit (includes left and right hinges)	854508-001
WLAN antenna, 670 mm	854450-001
WLAN antenna, 720 mm	854451-001



IMPORTANT: Make special note of each screw and screw lock size and location during removal and replacement.

Before removing the display assembly, follow these steps:

1. Shut down the computer.
2. Disconnect all external devices connected to the computer.
3. Disconnect the power from the computer by first unplugging the power cord from the AC outlet and then unplugging the AC adapter from the computer.
4. Remove the base enclosure (see [Base enclosure on page 20](#)), and then remove the following components:
 - a. Battery (see [Battery on page 22](#)).
 - b. Optical drive dummy (see [Optical drive dummy on page 22](#)).
 - c. Hard drive (see [Hard drive on page 23](#)).
 - d. Memory (see [Memory on page 25](#)).
 - e. WLAN module (see [WLAN module on page 28](#)).
 - f. Heat sink and fan (see [Heat sink and fan on page 30](#)).
 - g. Speakers (see [Speakers on page 32](#)).
 - h. Microphone (see [Microphone on page 34](#)).
 - i. System board (see [System board on page 36](#)).
 - j. WLAN cable (see [WLAN cable on page 39](#)).

Remove the display assembly:

1. Remove 2 screws from the right hinge and 3 screws from the left hinge **(1)**, and then remove the display assembly **(2)**.

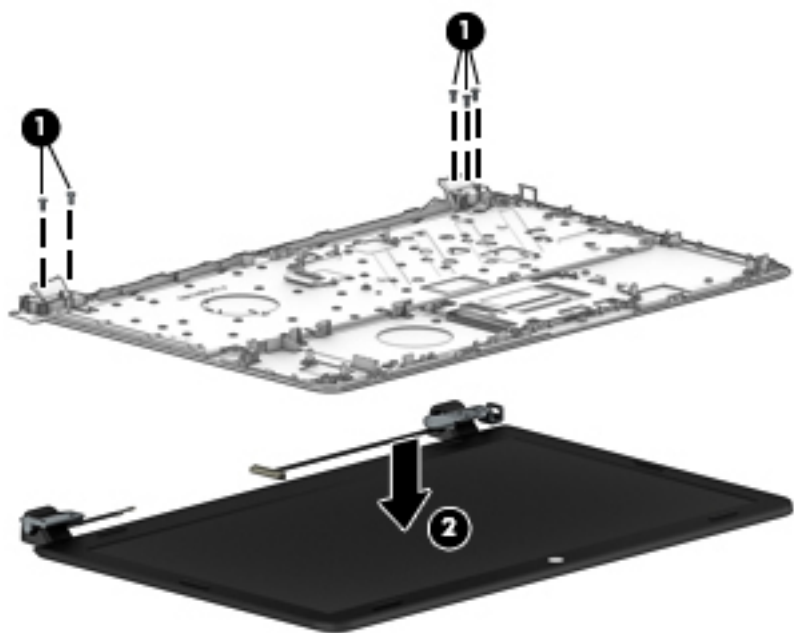

2. Remove 4 screws from the right hinge and 3 screws from the left hinge **(1)**, and then remove the display assembly **(2)**.

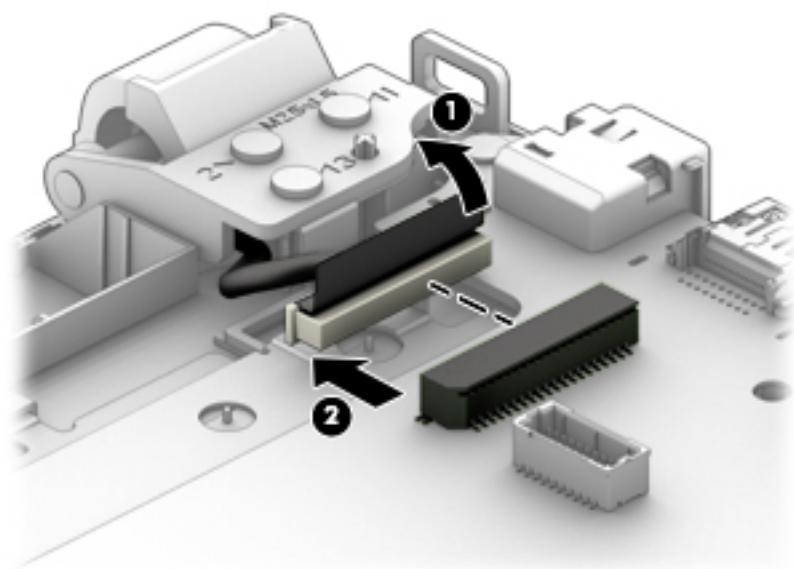

3. Slide a nylon flake tool **(1)** around the outer edge of the bezel to release the bezel from the screen **(2)**.

4. Lift the sides of the bezel (3), and then remove it (4).

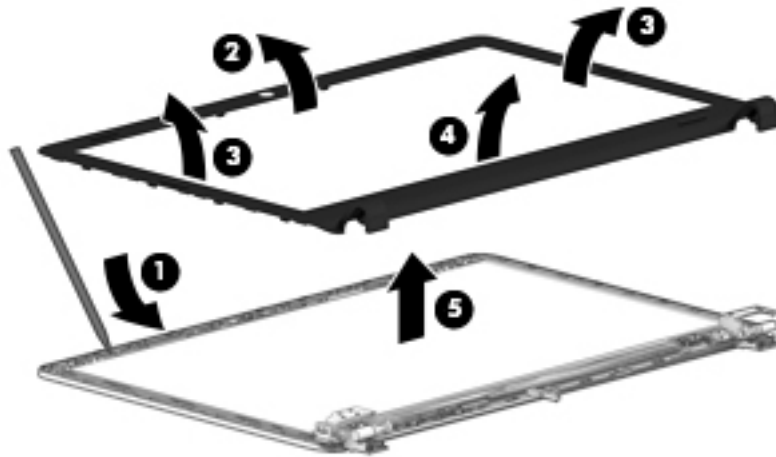

5. Remove the tape covering the display panel connector (1), and then disconnect it from the display panel (2).

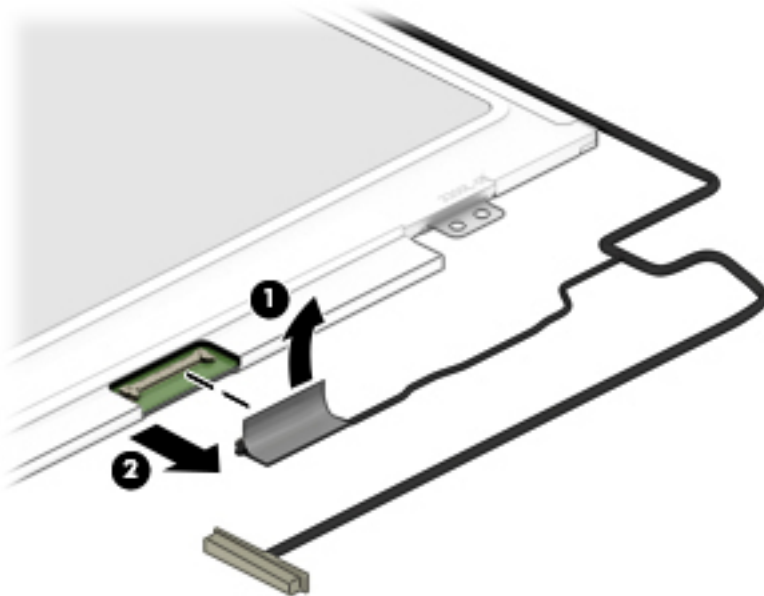

6. Remove 4 screws from the display panel (1), and then remove it (2).

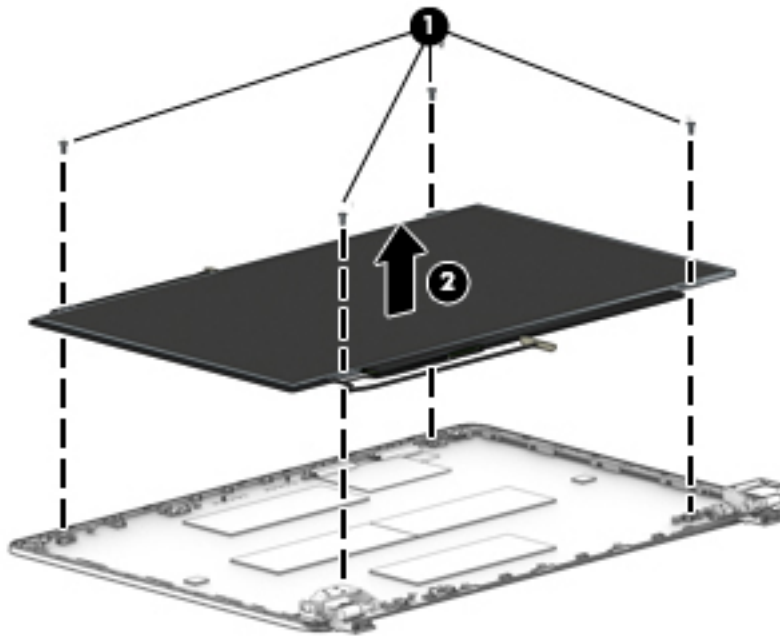

7. Remove 1 screw from the top of each hinge bracket (1) and 3 screws from each hinge (2) and then remove the hinge brackets (3).

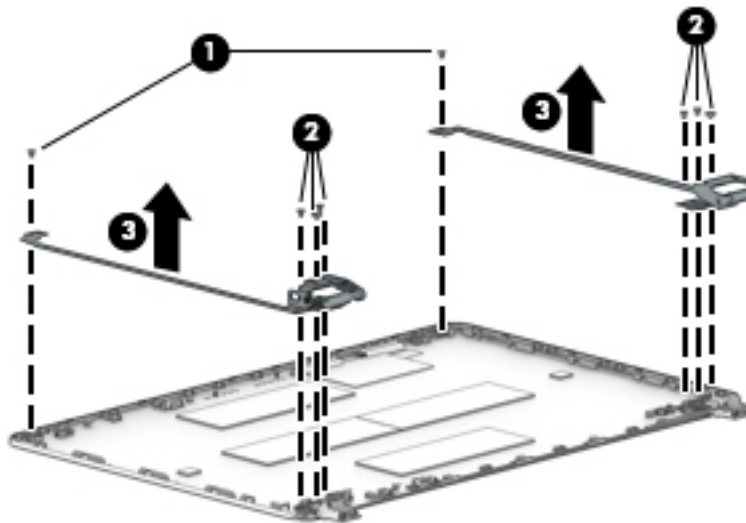

Reverse this procedure to install the display assembly.

Webcam

Description	Spare part number
Webcam	854509-001



IMPORTANT: Make special note of each screw and screw lock size and location during removal and replacement.

Before removing the webcam, follow these steps:

1. Shut down the computer.
2. Disconnect all external devices connected to the computer.
3. Disconnect the power from the computer by first unplugging the power cord from the AC outlet and then unplugging the AC adapter from the computer.
4. Remove the base enclosure (see [Base enclosure on page 20](#)), and then remove the following components:
 - a. Battery (see [Battery on page 22](#)).
 - b. Optical drive dummy (see [Optical drive dummy on page 22](#)).
 - c. Hard drive (see [Hard drive on page 23](#)).
 - d. Memory (see [Memory on page 25](#)).
 - e. WLAN module (see [WLAN module on page 28](#)).
 - f. Heat sink and fan (see [Heat sink and fan on page 30](#)).
 - g. Speakers (see [Speakers on page 32](#)).
 - h. Microphone (see [Microphone on page 34](#)).
 - i. System board (see [System board on page 36](#)).
 - j. WLAN cable (see [WLAN cable on page 39](#)).
 - k. Display assembly (see [Display assembly on page 41](#)).

Remove the webcam:

- ▲ Lift the webcam board **(1)**, disconnect the webcam cable **(2)**, and then use a nylon flake tool to remove the webcam **(3)**.

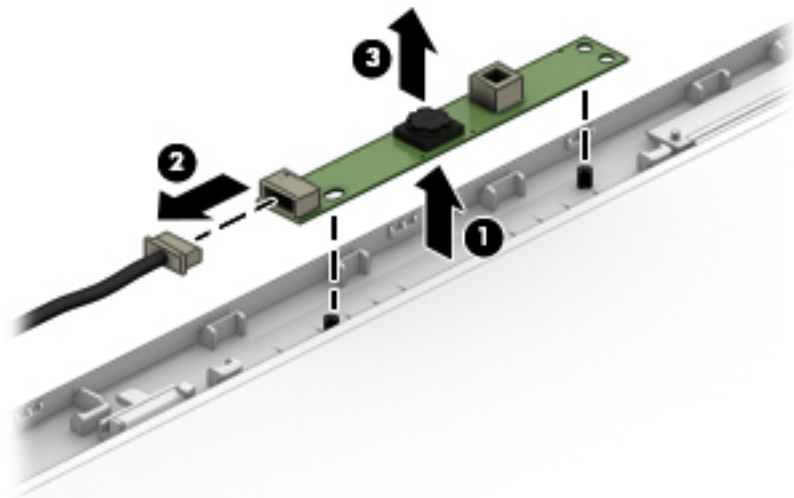

Reverse this procedure to install the webcam.

6 Using Setup Utility (BIOS)

Setup Utility, or Basic Input/Output System (BIOS), controls communication between all the input and output devices on the system (such as disk drives, display, keyboard, mouse, and printer). Setup Utility (BIOS) includes settings for the types of devices installed, the startup sequence of the computer, and the amount of system and extended memory.

 **NOTE:** To start Setup Utility on convertible computers, your computer must be in notebook mode and you must use the keyboard attached to your notebook.

Starting Setup Utility (BIOS)

 **CAUTION:** Use extreme care when making changes in Setup Utility (BIOS). Errors can prevent the computer from operating properly.

- ▲ Turn on or restart the computer, quickly press **esc**, and then press **f10**.

Updating Setup Utility (BIOS)

Updated versions of Setup Utility (BIOS) may be available on the HP website.

Most BIOS updates on the HP website are packaged in compressed files called *SoftPaqs*.

Some download packages contain a file named *Readme.txt*, which contains information regarding installing and troubleshooting the file.

Determining the BIOS version

To decide whether you need to update Setup Utility (BIOS), first determine the BIOS version on your computer.

To reveal the BIOS version information (also known as *ROM date* and *System BIOS*), use one of these options.

- HP Support Assistant
 1. Type `support` in the taskbar search box, and then select the **HP Support Assistant** app.
– or –
Click the question mark icon in the taskbar.
 2. Select **My PC**, and then select **Specifications**.
- Setup Utility (BIOS)
 1. Start Setup Utility (BIOS) (see [Starting Setup Utility \(BIOS\) on page 47](#)).
 2. Select **Main**, select **System Information**, and then make note of the BIOS version.
 3. Select **Exit**, select **No**, and then follow the on-screen instructions.

To check for later BIOS versions, see [Downloading a BIOS update on page 48](#).

Downloading a BIOS update

 **CAUTION:** To reduce the risk of damage to the computer or an unsuccessful installation, download and install a BIOS update only when the computer is connected to reliable external power using the AC adapter. Do not download or install a BIOS update while the computer is running on battery power, docked in an optional docking device, or connected to an optional power source. During the download and installation, follow these instructions:

- Do not disconnect power from the computer by unplugging the power cord from the AC outlet.
- Do not shut down the computer or initiate Sleep.
- Do not insert, remove, connect, or disconnect any device, cable, or cord.

 **NOTE:** If your computer is connected to a network, consult the network administrator before installing any software updates, especially system BIOS updates.

1. Type `support` in the taskbar search box, and then select the **HP Support Assistant** app.
– or –
Click the question mark icon in the taskbar.
2. Click **Updates**, and then click **Check for updates and messages**.
3. Follow the on-screen instructions.
4. At the download area, follow these steps:
 - a. Identify the most recent BIOS update and compare it to the BIOS version currently installed on your computer. If the update is more recent than your BIOS version, make a note of the date, name, or other identifier. You may need this information to locate the update later, after it has been downloaded to your hard drive.
 - b. Follow the on-screen instructions to download your selection to the hard drive.

Make a note of the path to the location on your hard drive where the BIOS update is downloaded. You will need to access this path when you are ready to install the update.

BIOS installation procedures vary. Follow any instructions that appear on the screen after the download is complete. If no instructions appear, follow these steps:

1. Type `file` in the taskbar search box, and then select **File Explorer**.
2. Click your hard drive designation. The hard drive designation is typically Local Disk (C:).
3. Using the hard drive path you recorded earlier, open the folder that contains the update.
4. Double-click the file that has an `.exe` extension (for example, `filename.exe`).

The BIOS installation begins.
5. Complete the installation by following the on-screen instructions.

 **NOTE:** After a message on the screen reports a successful installation, you can delete the downloaded file from your hard drive.

7 Backing up, restoring, and recovering

This chapter provides information about the following processes. The information in the chapter is standard procedure for most products.

- Creating recovery media and backups
- Restoring and recovering your system

Creating recovery media and backups

The following methods of creating recovery media and backups are available on select products only. Choose the available method according to your computer model.

- Use Windows tools to create system restore points and create backups of personal information.



NOTE: If storage is 32 GB or less, Microsoft System Restore is disabled by default.

Creating HP Recovery media (select products only)

If possible, check for the presence of the Recovery partition and the Windows partition. From the **Start** menu, select **File Explorer**, and then select **This PC**.

- If your computer does not list the Windows partition and the Recovery partition, you can obtain recovery media for your system from support. See the *Worldwide Telephone Numbers* booklet included with the computer. You can also find contact information on the HP website. Go to <http://www.hp.com/support>, select your country or region, and follow the on-screen instructions.

You can use Windows tools to create system restore points and create backups of personal information, see [Using Windows tools on page 50](#).

- If your computer does list the Recovery partition and the Windows partition, you can create recovery media after you successfully set up the computer. HP Recovery media can be used to perform system recovery if the hard drive becomes corrupted. System recovery reinstalls the original operating system and software programs that were installed at the factory and then configures the settings for the programs. HP Recovery media can also be used to customize the system or restore the factory image if you replace the hard drive.
 - Only one set of recovery media can be created. Handle these recovery tools carefully, and keep them in a safe place.
 - To create recovery discs, your computer must have an optical drive with DVD writer capability, and you must use only high-quality blank DVD-R, DVD+R, DVD-R DL, or DVD+R DL discs. You can also use a high-quality blank USB flash drive.
 - If your computer does not include an integrated optical drive with DVD writer capability, but you would like to create DVD recovery media, you can use an external optical drive (purchased separately) to create recovery discs. If you use an external optical drive, it must be connected directly to a USB port on the computer; the drive cannot be connected to a USB port on an external device, such as a USB hub. If you cannot create DVD media yourself, you can obtain recovery discs for your computer from HP. See the *Worldwide Telephone Numbers* booklet included with the computer. You can also find contact information on the HP website. Go to <http://www.hp.com/support>, select your country or region, and follow the on-screen instructions.

- Be sure that the computer is connected to AC power before you begin creating the recovery media.
- The creation process can take an hour or more. Do not interrupt the creation process.
- If necessary, you can exit the program before you have finished creating all of the recovery DVDs.

Using Windows tools

You can create recovery media, system restore points, and backups of personal information using Windows tools.



NOTE: If storage is 32 GB or less, Microsoft System Restore is disabled by default.

For more information and steps, see the Get started app.

- ▲ Select the **Start** button, and then select the **Get started** app.

Restore and recovery

There are several options for recovering your system. Choose the method that best matches your situation and level of expertise:



IMPORTANT: Not all methods are available on all products.

- Windows offers several options for restoring from backup, refreshing the computer, and resetting the computer to its original state. For more information see the Get started app.
 - ▲ Select the **Start** button, and then select the **Get started** app.
- If you want to recover the Windows partition to original factory content, you can choose the System Recovery option from the HP Recovery partition (select products only) or use the HP Recovery media. If you have not already created recovery media, see [Creating HP Recovery media \(select products only\) on page 49](#).
- On select products, if you want to recover the computer's original factory partition and content, or if you have replaced the hard drive, you can use the Factory Reset option of HP Recovery media.

8 Using HP PC Hardware Diagnostics (UEFI)

HP PC Hardware Diagnostics is a Unified Extensible Firmware Interface (UEFI) that allows you to run diagnostic tests to determine whether the computer hardware is functioning properly. The tool runs outside the operating system so that it can isolate hardware failures from issues that are caused by the operating system or other software components.

When HP PC Hardware Diagnostics (UEFI) detects a failure that requires hardware replacement, a 24-digit Failure ID code is generated. This ID code can then be provided to support to help determine how to correct the problem.

 **NOTE:** To start diagnostics on a convertible computer, your computer must be in notebook mode and you must use the keyboard attached.

To start HP PC Hardware Diagnostics (UEFI), follow these steps:

1. Turn on or restart the computer, and quickly press [esc](#).
2. Press [f2](#).

The BIOS searches three places for the diagnostic tools, in the following order:

- a. Connected USB drive

 **NOTE:** To download the HP PC Hardware Diagnostics (UEFI) tool to a USB drive, see [Downloading HP PC Hardware Diagnostics \(UEFI\) to a USB device on page 51](#).

- b. Hard drive
 - c. BIOS
3. When the diagnostic tool opens, select the type of diagnostic test you want to run, and then follow the on-screen instructions.

 **NOTE:** If you need to stop a diagnostic test, press [esc](#).

Downloading HP PC Hardware Diagnostics (UEFI) to a USB device

 **NOTE:** The HP PC Hardware Diagnostics (UEFI) download instructions are provided in English only, and you must use a Windows computer to download and create the HP UEFI support environment because only .exe files are offered.

There are two options to download HP PC Hardware Diagnostics to a USB device.

Download the latest UEFI version

1. Go to <http://www.hp.com/go/techcenter/pcdiags>. The HP PC Diagnostics home page is displayed.
2. In the HP PC Hardware Diagnostics section, select the **Download** link, and then select **Run**.

Download any version of UEFI for a specific product

1. Go to <http://www.hp.com/support>.
2. Select **Get software and drivers**.

3. Enter the product name or number.

– or –

Select **Identify now** to let HP automatically detect your product.

4. Select your computer, and then select your operating system.
5. In the **Diagnostic** section, follow the on-screen instructions to select and download the UEFI version you want.

9 Specifications

Computer specifications

	Metric	U.S.
Dimensions		
Width	342 mm	13.46 in
Depth	240 mm	9.45 in
Height (front to back)	23.5 mm	.93 in
Weight	1.81 kg (depending on configuration)	3.99 lb
Input power		
Operating voltage and current	19.5 V dc @ 2.31 – 45 W	
Temperature		
Operating	5°C to 35°C	41°F to 95°F
Nonoperating	-20°C to 60°C	-4°F to 140°F
Relative humidity (noncondensing)		
Operating	10% to 90%	
Nonoperating	5% to 95%	
Maximum altitude (unpressurized)		
Operating	-15 m to 3,048 m	-50 ft to 10,000 ft
Nonoperating	-15 m to 12,192 m	-50 ft to 40,000 ft
NOTE: Applicable product safety standards specify thermal limits for plastic surfaces. The device operates well within this range of temperatures.		

35.56 cm (14-in) display specifications

	Metric	U.S.
Dimensions		
Height	20.77 cm	8.175 in
Width	37.78 cm	14.875 in
Diagonal	39.62 cm	15.6 in
Number of colors	Up to 16.8 million	
Contrast ratio	500:1 (typical)	
Brightness	200 nits	
Pixel resolution		
Pitch	0.252mm x 0.252mm	
Format	1366x768	
Configuration	RGB vertical stripe	
Backlight	LED	
Character display	80 x 25	
Total power consumption	2.0 W	
Viewing angle	±65° horizontal, ±50° vertical (typical)	

Hard drive specifications

	500 GB*
Dimensions	
Height	7 mm
Width	70 mm
Weight	107 g max
Interface type	SATA
Transfer rate	300 MB/sec
Security	ATA security
Seek times (typical read, including setting)	
Single track	1.5 ms
Average	12.0 ms
Maximum	22.0 ms
Logical blocks	976,752,240
Disk rotational speed	5400 rpm
Operating temperature	0°C to 60°C (0°F to 140°F)

500 GB*

*Size refers to hard drive storage capacity. Actual accessible capacity is less. Actual drive specifications may differ slightly.

NOTE: Certain restrictions and exclusions apply. Contact support for details.

10 Power cord set requirements

The wide-range input feature of the computer permits it to operate from any line voltage from 100 to 120 volts AC, or from 220 to 240 volts AC.

The 3-conductor power cord set included with the computer meets the requirements for use in the country or region where the equipment is purchased.

Power cord sets for use in other countries and regions must meet the requirements of the country or region where the computer is used.

Requirements for all countries

The following requirements are applicable to all countries and regions:

- The length of the power cord set must be at least **1.0 m** (3.3 ft) and no more than **2.0 m** (6.5 ft).
- All power cord sets must be approved by an acceptable accredited agency responsible for evaluation in the country or region where the power cord set will be used.
- The power cord sets must have a minimum current capacity of 10 amps and a nominal voltage rating of 125 or 250 V AC, as required by the power system of each country or region.
- The appliance coupler must meet the mechanical configuration of an EN 60 320/IEC 320 Standard Sheet C13 connector for mating with the appliance inlet on the back of the computer.

Requirements for specific countries and regions

Country/region	Accredited agency	Applicable note number
Australia	EANSW	1
Austria	OVE	1
Belgium	CEBC	1
Canada	CSA	2
Denmark	DEMKO	1
Finland	FIMKO	1
France	UTE	1
Germany	VDE	1
Italy	IMQ	1
Japan	METI	3
The Netherlands	KEMA	1
Norway	NEMKO	1
The People's Republic of China	COC	5
South Korea	EK	4

Country/region	Accredited agency	Applicable note number
Sweden	SEMKO	1
Switzerland	SEV	1
Taiwan	BSMI	4
The United Kingdom	BSI	1
The United States	UL	2

- 1.** The flexible cord must be Type H05VV-F, 3-conductor, 1.0-mm² conductor size. Power cord set fittings (appliance coupler and wall plug) must bear the certification mark of the agency responsible for evaluation in the country or region where it will be used.
- 2.** The flexible cord must be Type SPT-3 or equivalent, No. 18 AWG, 3-conductor. The wall plug must be a two-pole grounding type with a NEMA 5-15P (15 A, 125 V) or NEMA 6-15P (15 A, 250 V) configuration.
- 3.** The appliance coupler, flexible cord, and wall plug must bear a “T” mark and registration number in accordance with the Japanese Dentori Law. The flexible cord must be Type VCT or VCTF, 3-conductor, 1.00-mm² conductor size. The wall plug must be a two-pole grounding type with a Japanese Industrial Standard C8303 (7 A, 125 V) configuration.
- 4.** The flexible cord must be Type RVV, 3-conductor, 0.75-mm² conductor size. Power cord set fittings (appliance coupler and wall plug) must bear the certification mark of the agency responsible for evaluation in the country or region where it will be used.
- 5.** The flexible cord must be Type VCTF, 3-conductor, 0.75-mm² conductor size. Power cord set fittings (appliance coupler and wall plug) must bear the certification mark of the agency responsible for evaluation in the country or region where it will be used.

11 Recycling

When a non-rechargeable or rechargeable battery has reached the end of its useful life, do not dispose of the battery in general household waste. Follow the local laws and regulations in your area for battery disposal.

HP encourages customers to recycle used electronic hardware, HP original print cartridges, and rechargeable batteries. For more information about recycling programs, see the HP Web site at <http://www.hp.com/recycle>.

Index

A

- AC adapter, spare part numbers 14
- action keys 8
- audio, product description 1
- audio-out (headphone)/audio-in (microphone) jack, identifying 4

B

- back cover, spare part number 13
- backups 49
- base enclosure
 - removal 20
 - spare part numbers 12
- base enclosure, spare part number 20
- battery
 - removal 22
 - spare part number 22
 - spare part numbers 12

BIOS

- determining version 47
- downloading an update 48
- starting the Setup Utility 47
- updating 47

buttons

- left TouchPad 5
- power 7
- right TouchPad 5

C

- components
 - display 3
 - front 4
 - left side 2
 - right side 2
 - top 5
- computer major components 10
- computer specifications 53
- connector, power 2

D

- DC connector
 - spare part numbers 14
- display
 - specifications 54

- display assembly
 - removal 41
 - spare part numbers 41
 - subcomponents 13
- display bezel
 - spare part number 13
- display panel
 - product description 1

E

- esc key, identifying 8
- Ethernet, product description 1

F

- fan
 - removal 30
 - spare part numbers 12, 30
- fn key, identifying 8

H

- hard drive
 - product description 1
 - removal 23
 - spare part numbers 12, 23
 - specifications 54
- HDMI port
 - identifying 2
- heat sink
 - removal 30
 - spare part numbers 12, 30
- hinge kit
 - spare part number 13
- HP PC Hardware Diagnostics (UEFI) using 51
- HP Recovery media
 - creating 49

J

- jacks
 - audio-out (headphone)/audio-in (microphone) 4
 - network 2
 - RJ-45 (network) 2

K

- keys
 - esc 8
 - fn 8
 - Windows 8

L

- labels
 - serial number 9
- lights
 - power light 6
 - RJ-45 (network) status 2

M

- memory
 - removal 25
 - spare part number 12
 - spare part numbers 25
- memory card reader, identifying 4
- memory card, identifying 4
- memory module
 - product description 1
- microphone
 - identifying 6
 - product description 1
 - removal 34
 - spare part numbers 34
- microphone, spare part number 13
- middle frame, spare part number 14
- model name 1

N

- network jack, identifying 2

O

- operating system, product description 1
- optical drive dummy
 - product description 1
 - removal 22
 - spare part number 12
 - spare part numbers 22
- optical drive eject button, identifying 2

optical drive, identifying 2

P

panel

 spare part number 13

ports

 HDMI 2

 product description 1

 USB 2.0 3, 4

 USB 3.0 3

power button, identifying 7

power connector, identifying 2

power cord

 set requirements 56

power cord, spare part number 14

power light, identifying 6

power requirements, product description 1

processor

 product description 1

product description

 audio 1

 display panel 1

 Ethernet 1

 external media cards 1

 hard drive 1

 memory module 1

 microphone 1

 operating system 1

 optical drive dummy 1

 ports 1

 power requirements 1

 processors 1

 product name 1

 security 1

 serviceability 1

 video 1

 wireless 1

product name 1

product name and number,
 computer 9

R

recover

 options 50

recovery

 discs 49

 supported discs 49

recovery media

 creating 49

regulatory information 9

removal/replacement

 procedures 20

RJ-45 (network) jack, identifying 2

RJ-45 (network) status lights,
 identifying 2

RTC battery

 spare part number 12

RTC battery, spare part number 14

S

screw kit, spare part number 14

security cable slot, identifying 2

security, product description 1

serial number 9

serial number, computer 9

serviceability, product description 1

slots

 memory card reader 4

 security cable 2

speaker

 removal 32

 spare part numbers 32

speaker kit

 spare part number 12

speakers

 identifying 4

specifications

 computer 53

 display 54

 hard drive 54

supported discs, recovery 49

system board

 removal 36

 spare part number 12

 spare part numbers 36

system information

 locating 9

system restore point

 creating 50

system restore point, creating 49

T

top cover

 spare part numbers 12

TouchPad

 buttons 5

TouchPad zone, identifying 5

U

USB 2.0 port, identifying 3, 4

USB 3.0 port, identifying 3

V

vent, identifying 3

video, product description 1

W

warranty period 9

webcam

 identifying 3

 removal 45

 spare part numbers 12, 45

webcam light, identifying 3

Windows

 system restore point 49, 50

Windows key, identifying 8

Windows tools

 using 50

wireless, product description 1

WLAN antennas, identifying 3

WLAN antennas, spare part
 numbers 13

WLAN cable

 removal 39

 spare part number 13

 spare part numbers 39

WLAN module

 removal 28

 spare part number 12

 spare part numbers 28