



**HP Pavilion x360 Convertible PC  
(model numbers 15-bk100 through 15-  
bk199 and 15-bk000 through 15-bk099)**

**Maintenance and Service Guide  
IMPORTANT! This document is intended for  
HP authorized service providers only.**

© Copyright 2016 HP Development Company, L.P.

#### Product notice

Bluetooth is a trademark owned by its proprietor and used by HP Inc. under license. Intel, Core, and Pentium are U.S. registered trademarks of Intel Corporation. Microsoft and Windows are either registered trademarks or trademarks of Microsoft Corporation in the United States and/or other countries. SD Logo is a trademark of its proprietor.

This guide describes features that are common to most models. Some features may not be available on your computer.

Not all features are available in all editions of Windows 10. This computer may require upgraded and/or separately purchased hardware, drivers and/or software to take full advantage of Windows 10 functionality. See <http://www.microsoft.com> for details.

The information contained herein is subject to change without notice. The only warranties for HP products and services are set forth in the express warranty statements accompanying such products and services. Nothing herein should be construed as constituting an additional warranty. HP shall not be liable for technical or editorial errors or omissions contained herein.

Second Edition: August 2016

First Edition: May 2016

Document Part Number: 862394-002

## Safety warning notice

---

 **WARNING!** To reduce the possibility of heat-related injuries or of overheating the device, do not place the device directly on your lap or obstruct the device air vents. Use the device only on a hard, flat surface. Do not allow another hard surface, such as an adjoining optional printer, or a soft surface, such as pillows or rugs or clothing, to block airflow. Also, do not allow the AC adapter to contact the skin or a soft surface, such as pillows or rugs or clothing, during operation. The device and the AC adapter comply with the user-accessible surface temperature limits defined by the International Standard for Safety of Information Technology Equipment (IEC 60950).

---



---

# Table of contents

<b>1 Product description .....</b>	<b>1</b>
<b>2 External component identification .....</b>	<b>5</b>
Locating hardware .....	5
Locating software .....	5
Display .....	6
Keys .....	7
Lights .....	8
TouchPad .....	9
Left side .....	10
Right side .....	12
Bottom .....	13
<b>3 Illustrated parts catalog .....</b>	<b>14</b>
Locating the model number, product number, serial number, and warranty information .....	14
Computer major components .....	16
Display components .....	21
Miscellaneous parts .....	22
<b>4 Removal and replacement procedures preliminary requirements .....</b>	<b>23</b>
Tools required .....	23
Service considerations .....	23
Plastic parts .....	23
Cables and connectors .....	23
Drive handling .....	24
Grounding guidelines .....	25
Electrostatic discharge damage .....	25
Packaging and transporting guidelines .....	26
Workstation guidelines .....	26
Equipment guidelines .....	27
<b>5 Removal and replacement procedures .....</b>	<b>28</b>
Component replacement procedures .....	28
Keyboard/top cover .....	28
Battery .....	33
Speakers .....	34

Hard drive .....	35
RTC battery .....	36
WLAN module .....	37
Connector board .....	39
System board .....	40
Fan/heat sink assembly .....	44
Memory module .....	47
Display assembly .....	48
Power button board .....	57
Power connector cable .....	58
<b>6 Using Setup Utility (BIOS) .....</b>	<b>59</b>
Starting Setup Utility (BIOS) .....	59
Updating Setup Utility (BIOS) .....	59
Determining the BIOS version .....	59
Downloading a BIOS update .....	60
<b>7 Using HP PC Hardware Diagnostics (UEFI) .....</b>	<b>61</b>
Downloading HP PC Hardware Diagnostics (UEFI) to a USB device .....	61
<b>8 Specifications .....</b>	<b>63</b>
Computer specifications .....	63
<b>9 Backing up, restoring, and recovering .....</b>	<b>65</b>
Creating recovery media and backups .....	65
Creating HP Recovery media (select products only) .....	65
Using Windows tools .....	66
Restore and recovery .....	67
Recovering using HP Recovery Manager .....	67
What you need to know before you get started .....	67
Using the HP Recovery partition (select products only) .....	68
Using HP Recovery media to recover .....	68
Changing the computer boot order .....	69
Removing the HP Recovery partition (select products only) .....	70
<b>10 Power cord set requirements .....</b>	<b>71</b>
Requirements for all countries .....	71
Requirements for specific countries and regions .....	71
<b>11 Recycling .....</b>	<b>73</b>







# 1 Product description

Category	Description	HP Pavilion x360 Convertible PC (model numbers 15-bk100 through 15-bk199)	HP Pavilion x360 Convertible PC (model numbers 15-bk000 through 15-bk099)
<b>Product Name</b>	HP Pavilion x360 Convertible PC (model numbers 15-bk100 through 15-bk199)	√	
	HP Pavilion x360 Convertible PC (model numbers 15-bk000 through 15-bk099)		√
<b>Processors</b>	<ul style="list-style-type: none"> <li>Intel® Core™ i5-7200U 2.50-GHz (SC turbo up to 3.10-GHz) processor (2133-MHz front-side bus (FSB), 3.0-MB L3 cache, dual core, 15-W)</li> </ul>	√	
	<ul style="list-style-type: none"> <li>Intel Core i3-7100U 2.40-GHz processor (2133-MHz FSB, 3.0-MB L3 cache, dual core, 15-W)</li> </ul>		
	<ul style="list-style-type: none"> <li>Intel Core i7-6500U 2.50-GHz (SC turbo up to 3.10-GHz) processor (1600-MHz FSB, 4.0-MB L3 cache, dual core, 15-W)</li> </ul>	√	√
	<ul style="list-style-type: none"> <li>Intel Core i5-6200U 2.30-GHz (SC turbo up to 2.80-GHz) processor (1600-MHz FSB, 3.0-MB L3 cache, dual core, 15-W)</li> </ul>		
	<ul style="list-style-type: none"> <li>Intel Core i3-6100U 2.30-GHz processor (1600-MHz FSB, 3.0-MB L3 cache, dual core, 15-W)</li> <li>Intel Pentium™ 4405U 2.10-GHz processor (1600-MHz FSB, 2.0-MB L3 cache, dual core, 15-W)</li> </ul>		
<b>Chipset</b>	Intel integrated soldered-on-chip (SOC)	√	√
<b>Graphics</b>	<p><b>Internal graphics:</b></p> <p>Intel HD Graphics 620 on computer models equipped with an Intel Core i5-7200U or Intel Core i3-7100U processor</p> <p>Intel HD Graphics 520 on computer models equipped with an Intel Core i7-6500U, Intel Core</p>	√	

Category	Description	HP Pavilion x360 Convertible PC (model numbers 15-bk100 through 15-bk199)	HP Pavilion x360 Convertible PC (model numbers 15-bk000 through 15-bk099)
<b>Graphics</b> <i>(continued)</i>	i5-6200U, Intel Core i3-6100U, or Intel Pentium processor  Support for HD decode, DX12, and high-definition multimedia interface (HDMI) v1.4	√	√
<b>Panel</b>	15.6-in, full-high-definition (FHD), AntiGlare (AG; 1920×1080), white light- emitting diode (WLED), UWVA, embedded DisplayPort (eDP), slim-flat (3.2-mm), TouchScreen display with flush glass, multitouch enabled, 220 nits, 16:9 ultra wide aspect ratio;  15.6-in, high-definition (HD), BrightView (BV; 1366×768), WLED, SVA, eDP, slim-flat (3.2- mm), TouchScreen display with flush glass, multitouch enabled, 220 nits, 16:9 ultra wide aspect ratio;  Support for active stylus	√	√
<b>Memory module</b>	Two SODIMM slots, non- accessible/non-upgradeable  Support for DDR3L-1600 dual channel  <b>Support for up to 8-GB maximum system memory in the following configurations:</b> <ul style="list-style-type: none"> <li>• 8192-MB: (8192-MB × 1)</li> <li>• 6144-MB: (4096-MB + 2048-MB)</li> <li>• 4096-MB: (4096-MB × 1)</li> </ul>	√	√
<b>Hard drive</b>	<b>Hard drives:</b>  Support for all 7.2- and 7.0-mm, SATA, 2.5-in hard drives  Support for Accelerometer hard drive protection  Support for the following hard drives: <ul style="list-style-type: none"> <li>• 1-TB, 5400-rpm, SATA, 7.2- mm hard drive</li> <li>• 500-GB, 5400-rpm, SATA, 7.0-mm hard drive</li> </ul> Support for a 500-GB, 5400- rpm, SATA, 8-GB hybrid, 7.0-mm, solid-state hard drive	√	√

Category	Description	HP Pavilion x360 Convertible PC (model numbers 15-bk100 through 15-bk199)	HP Pavilion x360 Convertible PC (model numbers 15-bk000 through 15-bk099)
<b>Optical drive</b>	Support for HP USB external DVD ±RW DL SuperMulti Drive	√	√
<b>Audio and video</b>	HP TrueVision HD webcam with indicator light, 720p by 30 frames per second, f2.0  Bang & Olufsen audio  Dual speakers  HD Audio (Conexant CX7700)  Integrated dual-array microphones with appropriate beam-forming, echo- cancellation, and noise suppression software  Support for HP Noise Cancellation	√	√
<b>Ethernet</b>	Integrated 10/100/1000 network interface controller (NIC)	√	√
<b>Sensors</b>	Accelerometer (2, including one for hard drive protection)  E-compass  Gyroscope  Sensor hub	√	√
<b>Wireless</b>	Integrated wireless local area network (WLAN) options by way of wireless module  Two WLAN antennas  Support for the following WLAN modules:	√	√
	<ul style="list-style-type: none"> <li>Intel Dual Band Wireless-AC 3168 802.11 AC 1×1 WiFi + Bluetooth® 4.2 Combo Adaptor (non-vPro)</li> </ul>	√	
	<ul style="list-style-type: none"> <li>Intel Dual Band Wireless-AC 3165 802.11 AC 1×1 WiFi + Bluetooth 4.2 Combo Adapter</li> </ul>	√	√
	Compatible with MiraCast- certified devices  Support for Intel WiDi	√	√
<b>External media cards</b>	Micro-Secure Digital (SD) media reader slot	√	√
<b>Ports</b>	<ul style="list-style-type: none"> <li>Audio-in (mono microphone)/audio-out</li> </ul>	√	√

Category	Description	HP Pavilion x360 Convertible PC (model numbers 15-bk100 through 15-bk199)	HP Pavilion x360 Convertible PC (model numbers 15-bk000 through 15-bk099)
<b>Ports</b> <i>(continued)</i>	<ul style="list-style-type: none"> <li>(stereo headphone) combination</li> <li>AC Smart Pin adapter plug</li> <li>HDMI v1.4 supporting up to 1920×1080 @ 60 Hz</li> <li>RJ-45/Ethernet</li> <li>USB 3.0 (2)</li> <li>USB 2.0</li> </ul>	√	√
<b>Keyboard/pointing devices</b>	Full-size, backlit, island-style keyboard with numeric keypad  TouchPad requirements: <ul style="list-style-type: none"> <li>ClickPad with image sensor</li> <li>Multitouch gestures enabled</li> <li>Support for Windows modern trackpad gestures</li> <li>Taps enabled as default</li> </ul>	√	√
<b>Power requirements</b>	Support for the following AC adapters: <ul style="list-style-type: none"> <li>65-W HP Smart AC adapter (non-PFC, S-3P, 4.5-mm)</li> <li>45-W HP Smart AC adapter (non-PFC, RC, 4.5-mm)</li> </ul>	√	√
	<ul style="list-style-type: none"> <li>65-W HP Smart AC adapter (non-PFC, EM, 4.5-mm)</li> </ul>	√	
	Support for a C5, 1.00-meter (3.28-foot) power cord varying by country/region	√	√
	Support for a 3-cell, 48-WHr, 4.2-AHr, Li-ion battery	√	√
<b>Security</b>	Support for Trusted Platform Module (TPM) 2.0 and security cable lock	√	√
<b>Operating system</b>	<b>Preinstalled:</b> Windows 10  <b>For developed market (ML):</b> Windows 10 Home ML and Windows 10 Home High End ML  <b>For emerging market (EM/SL):</b> Windows 10 Home EM/SL and Windows 10 Home High End EM/SL/China	√	√
<b>Serviceability</b>	<b>End user replaceable part:</b> AC adapter	√	√

---

## 2 External component identification

### Locating hardware

To find out what hardware is installed on your computer:

- ▲ Type `device manager` in the taskbar search box, and then select the **Device Manager** app.

A list displays all the devices installed on your computer.

For information about system hardware components and the system BIOS version number, press `fn+esc` (select products only).

### Locating software

To find out what software is installed on your computer:

- ▲ Select the **Start** button, and then select **All apps**.

– or –

Right-click the **Start** button, and then select **Programs and Features**.

# Display



Item	Component	Description
(1)	Internal microphones (2)	Record sound.
(2)	Webcam light	On: The webcam is in use.
(3)	Webcam	Allows you to video chat, record video, and record still photographs. Some products also provide HD or 3D capability, apps for gaming, or facial recognition software for Windows Hello.  To use the webcam:  ▲ Type <code>camera</code> in the taskbar search box, and then select <b>Camera</b> .
(4)	WLAN antennas*	Send and receive wireless signals to communicate with WLANs.

\*The antennas are not visible from the outside of the computer, and the antenna location may vary. For optimal transmission, keep the areas immediately around the antennas free from obstructions.

For wireless regulatory notices, see the section of the *Regulatory, Safety, and Environmental Notices* that applies to your country or region.

To access this guide:

- ▲ Select the **Start** button, select **All apps**, select **HP Help and Support**, and then select **HP Documentation**.

# Keys

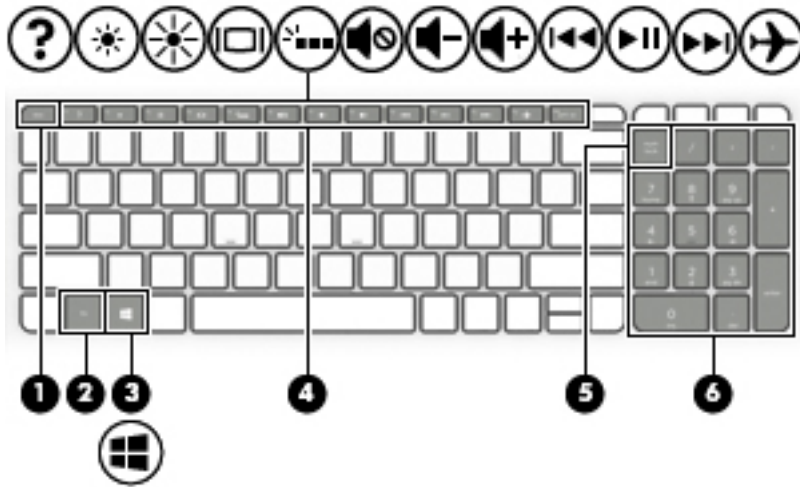

Item	Component	Description
(1)	esc key	Displays system information when pressed in combination with the <b>fn</b> key.
(2)	fn key	Displays system information when pressed in combination with the <b>esc</b> key.
(3)	Windows key	Opens the <b>Start</b> menu. <b>NOTE:</b> Pressing the Windows key again will close the <b>Start</b> menu.
(4)	Action keys	Execute frequently used system functions. <b>NOTE:</b> On select products, the <b>f5</b> action key turns the keyboard backlight feature off or on.
(5)	num lock key (select products only)	Alternates between the navigational and numeric functions on the integrated numeric keypad.
(6)	Integrated numeric keypad (select products only)	When <b>num lock</b> is on, the keypad can be used like an external numeric keypad.

# Lights

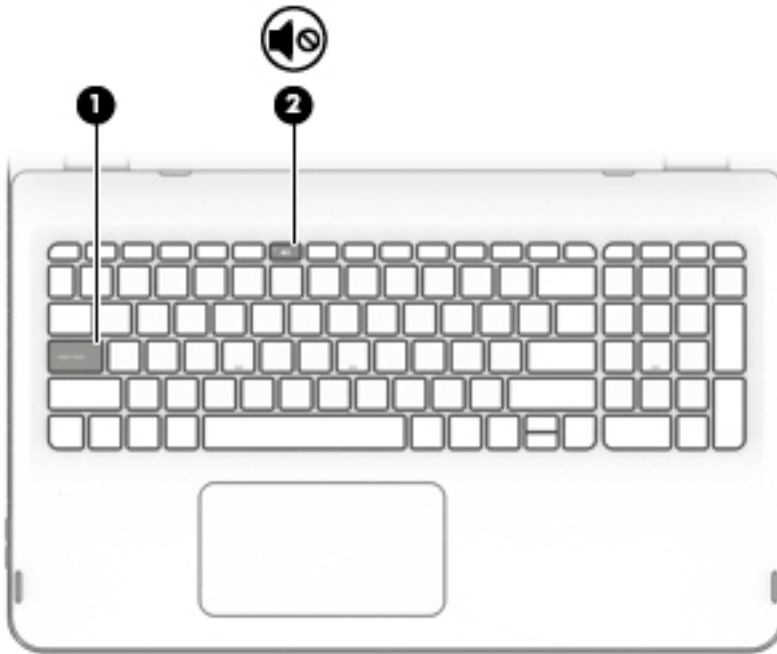

Item	Component	Description
(1)	Caps lock light	On: Caps lock is on, which switches the key input to all capital letters.
(2)	Mute light	<ul style="list-style-type: none"><li>• Amber: Computer sound is off.</li><li>• Off: Computer sound is on.</li></ul>



# TouchPad

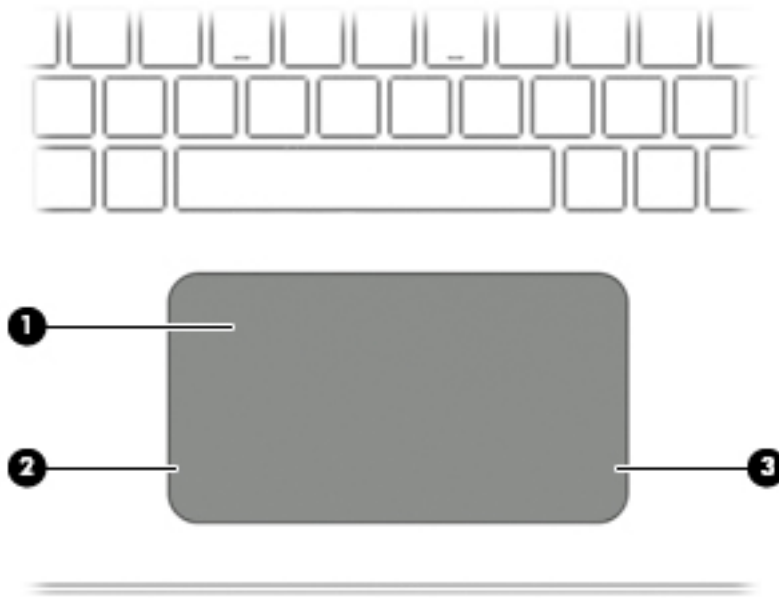

Item	Component	Description
(1)	TouchPad zone	Reads your finger gestures to move the pointer or activate items on the screen.
(2)	Left TouchPad button	Functions like the left button on an external mouse.
(3)	Right TouchPad button	Functions like the right button on an external mouse.

## Left side

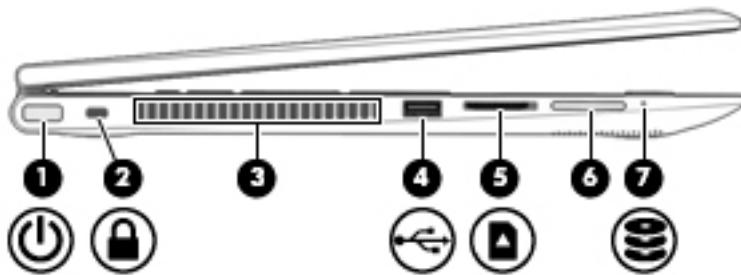

Item	Component	Description
(1)	Power button	<ul style="list-style-type: none"> <li>When the computer is off, press the button to turn on the computer.</li> <li>When the computer is on, press the button briefly to initiate Sleep.</li> <li>When the computer is in the Sleep state, press the button briefly to exit Sleep.</li> <li>When the computer is in Hibernation, press the button briefly to exit Hibernation.</li> </ul> <p><b>CAUTION:</b> Pressing and holding down the power button results in the loss of unsaved information.</p> <p>If the computer has stopped responding and shutdown procedures are ineffective, press and hold the power button down for at least 5 seconds to turn off the computer.</p> <p>To learn more about your power settings, see your power options.</p> <p>▲ Type <code>power</code> in the taskbar search box, and then select <b>Power and sleep settings</b>.</p> <p>– or –</p> <p>Right-click the <b>Start</b> button, and then select <b>Power Options</b>.</p>
(2)	Security cable slot	<p>Attaches an optional security cable to the computer.</p> <p><b>NOTE:</b> The security cable is designed to act as a deterrent, but it may not prevent the computer from being mishandled or stolen.</p>
(3)	Vent	<p>Enables airflow to cool internal components.</p> <p><b>NOTE:</b> The computer fan starts up automatically to cool internal components and prevent overheating. It is normal for the internal fan to cycle on and off during routine operation.</p>
(4)	USB 2.0 port	<p>Connects an optional USB device, such as a keyboard, mouse, external drive, printer, scanner, or USB hub.</p>
(5)	Memory card reader	<p>Reads optional memory cards that enable you to store, manage, share, or access information.</p> <p>To insert a card:</p> <ol style="list-style-type: none"> <li>Hold the card label-side up, with connectors facing the computer.</li> </ol>

Item	Component	Description
		<p>2. Insert the card into the memory card reader, and then press in on the card until it is firmly seated.</p> <p>To remove a card:</p> <p>▲ Press in on the card, and then remove it from the memory card reader.</p>
(6)	Volume button	<p>Control speaker volume on the computer.</p> <ul style="list-style-type: none"> <li>• Notebook and interactive stand mode: <ul style="list-style-type: none"> <li>◦ To increase the volume, press the edge closest to the hinge.</li> <li>◦ To decrease the volume, press the edge closest to the TouchPad.</li> </ul> </li> <li>• Tablet and entertainment stand mode: <ul style="list-style-type: none"> <li>◦ To increase the volume, press the edge closest to the TouchPad.</li> <li>◦ To decrease the volume, press the edge closest to the hinge.</li> </ul> </li> </ul>
(7)	Drive light	<ul style="list-style-type: none"> <li>• Blinking white: The hard drive is being accessed.</li> <li>• Amber: HP 3D DriveGuard has temporarily parked the hard drive.</li> </ul>

## Right side

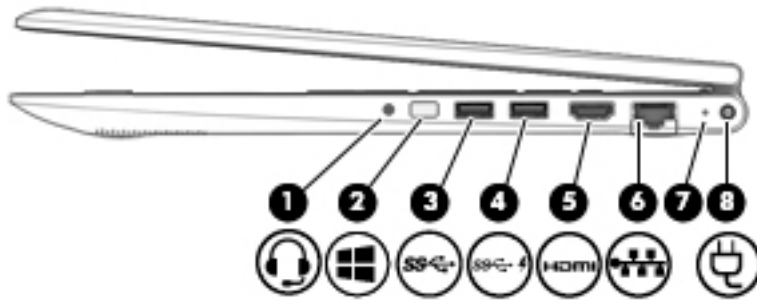

Item	Component	Description
(1)	Audio-out (headphone)/Audio-in (microphone) combo jack	<p>Connects optional powered stereo speakers, headphones, earbuds, a headset, or a television audio cable. Also connects an optional headset microphone. This jack does not support optional standalone microphones.</p> <p><b>WARNING!</b> To reduce the risk of personal injury, adjust the volume before putting on headphones, earbuds, or a headset. For additional safety information, refer to the <i>Regulatory, Safety, and Environmental Notices</i>.</p> <p>To access this guide:</p> <ul style="list-style-type: none"> <li>▲ Select the <b>Start</b> button, select <b>All apps</b>, select <b>HP Help and Support</b>, and then select <b>HP Documentation</b>.</li> </ul> <p><b>NOTE:</b> When a device is connected to the jack, the computer speakers are disabled.</p>
(2)	Windows Button	<p>Opens the <b>Start</b> menu.</p> <p><b>NOTE:</b> Pressing the Windows button again will close the <b>Start</b> menu.</p>
(3)	USB 3.0 port	<p>Connects an optional USB device, such as a keyboard, mouse, external drive, printer, scanner, or USB hub.</p>
(4)	USB 3.0 charging (powered) port	<p>Connects an optional USB device, such as a keyboard, mouse, external drive, printer, scanner, or USB hub. Standard USB ports will not charge all USB devices or will charge using a low current. Some USB devices require power and require you to use a powered port.</p> <p><b>NOTE:</b> USB charging ports can also charge select models of cell phones and MP3 players, even when the computer is off.</p>
(5)	HDMI port	<p>Connects an optional video or audio device, such as a high-definition television, any compatible digital or audio component, or a high-speed HDMI device.</p>
(6)	RJ-45 (network) jack/status lights	<p>Connects a network cable.</p> <ul style="list-style-type: none"> <li>• White: The network is connected.</li> <li>• Amber: Activity is occurring on the network.</li> </ul>
(7)	AC adapter and battery light	<ul style="list-style-type: none"> <li>• White: The AC adapter is connected and the battery is fully charged.</li> <li>• Blinking white: The AC adapter is disconnected and the battery has reached a low battery level.</li> </ul>

Item	Component	Description
(7)	AC adapter and battery light <i>(continued)</i>	<ul style="list-style-type: none"> <li>Amber: The AC adapter is connected and the battery is charging.</li> <li>Off: The battery is not charging.</li> </ul>
(8)	Power connector	Connects an AC adapter.

## Bottom

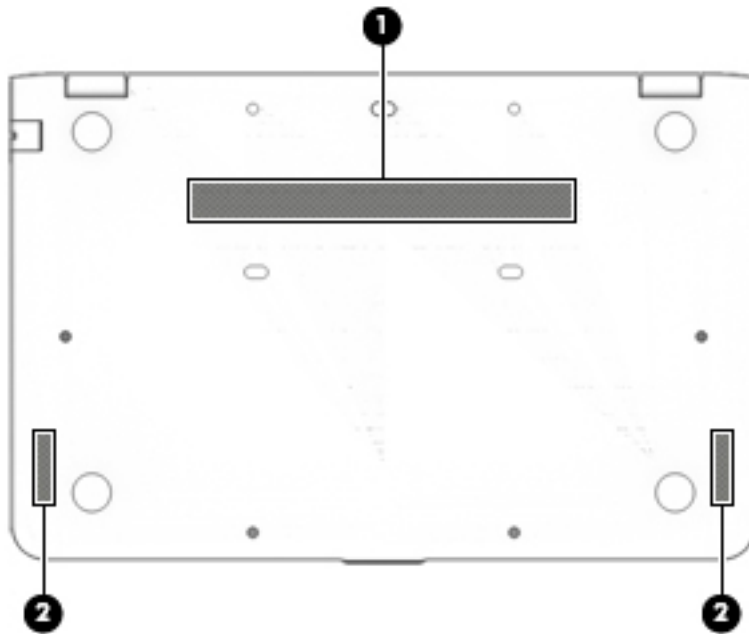

Item	Component	Description
(1)	Vent	<p>Enable airflow to cool internal components.</p> <p><b>NOTE:</b> The computer fan starts up automatically to cool internal components and prevent overheating. It is normal for the internal fan to cycle on and off during routine operation.</p>
(2)	Speakers (2)	Produce sound.

# 3 Illustrated parts catalog

**NOTE:** HP continually improves and changes product parts. For complete and current information on supported parts for your computer, go to <http://partsurfer.hp.com>, select your country or region, and then follow the on-screen instructions.

## Locating the model number, product number, serial number, and warranty information

The model number (1), product number (2), serial number (3), and warranty information (4) are located on the bottom of the computer. This information may be needed when travelling internationally or when contacting support.

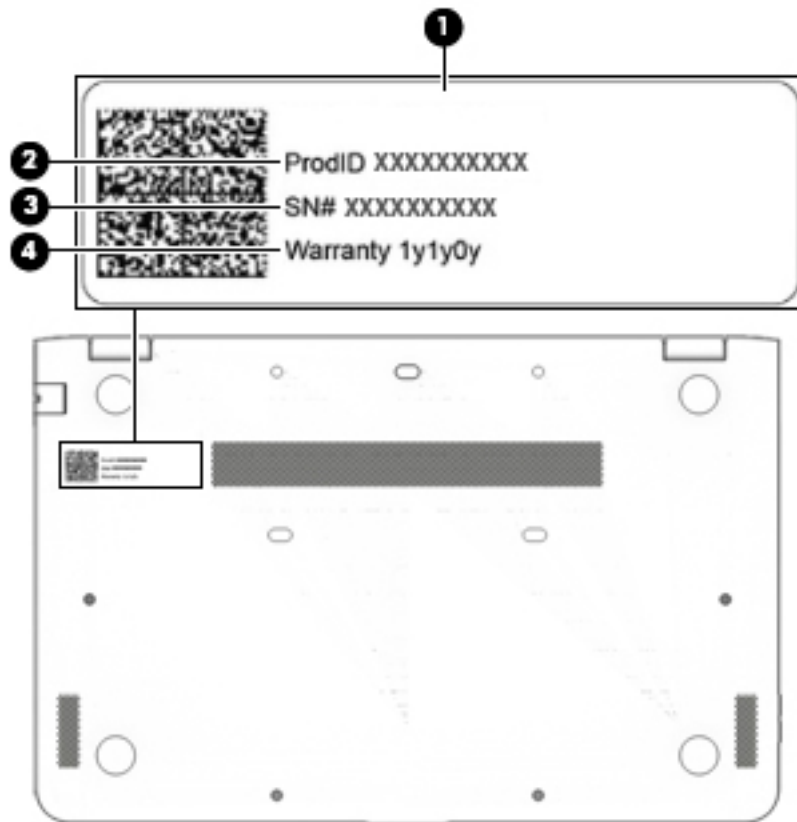

Item	Description	Function
(1)	Model description	This is the alphanumeric identifier used to locate documents, drivers, and support for the computer.
(3)	Product number/Part number (p/n)	This number provides specific information about the product's hardware components. The part number helps a service technician to determine what components and parts are needed.

<b>Item</b>	<b>Description</b>	<b>Function</b>
<b>(3)</b>	Serial number (s/n)	This is an alphanumeric identifier that is unique to each product.
<b>(4)</b>	Warranty period	This number describes the duration of the warranty period for the computer.

## Computer major components

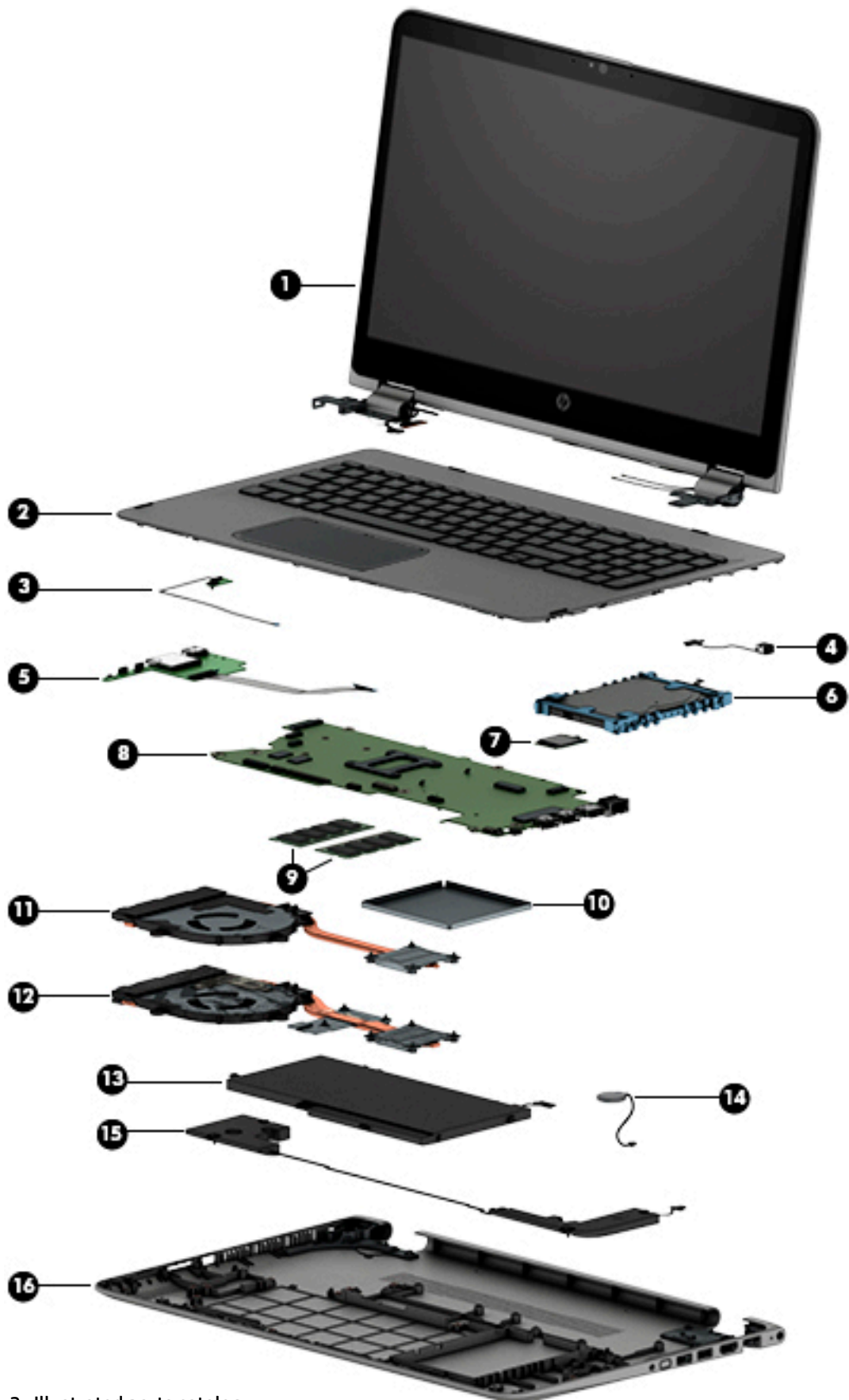



Item	Component	Spare part number
(1)	<b>Display assembly:</b> The display assembly is spared at the subcomponent level only. For more display assembly spare part information, see <a href="#">Display components on page 21</a> .	
(2)	<b>Keyboard/top cover with backlight</b> (includes backlight cable, keyboard cable, TouchPad, and TouchPad cable):	
	In cardinal red finish for use in the United States	862649-001
	In natural silver finish for use in the United States	862647-001
	In sport purple finish for use in the United States	862651-001
	<b>Keyboard/top cover in cardinal red finish</b> (includes keyboard cable, TouchPad, and TouchPad cable):	
	For use in Belgium	862650-A41
	For use in Bulgaria	862650-261
	For use in the Czech Republic and Slovakia	862650-FL1
	For use in Denmark, Finland, and Norway	862650-DH1
	For use in France	862650-051
	For use in Germany	862650-041
	For use in Greece	862650-151
	For use in Hungary	862650-211
	For use in Israel	862650-BB1
	For use in Italy	862650-061
	For use in the Netherlands	862650-B31
	For use in Portugal	862650-131
	For use in Romania	862650-271
	For use in Russia	862650-251
	For use in Saudi Arabia	862650-171
	For use in Slovenia	862650-F81
	For use in Spain	862650-071
	For use in Switzerland	862650-BG1
	For use in Turkey	862650-141
	For use in the United Kingdom	862650-031
	For use in the United States	862650-001
	<b>Keyboard/top cover in natural silver finish</b> (includes keyboard cable, TouchPad, and TouchPad cable):	
	For use in Belgium	862648-A41
	For use in Bulgaria	862648-261
	For use in the Czech Republic and Slovakia	862648-FL1
	For use in Denmark, Finland, and Norway	862648-DH1
	For use in France	862648-051

<b>Item</b>	<b>Component</b>	<b>Spare part number</b>
	For use in Germany	862648-041
	For use in Greece	862648-151
	For use in Hungary	862648-211
	For use in Israel	862648-BB1
	For use in Italy	862648-061
	For use in the Netherlands	862648-B31
	For use in Portugal	862648-131
	For use in Romania	862648-271
	For use in Russia	862648-251
	For use in Saudi Arabia	862648-171
	For use in Slovenia	862648-F81
	For use in Spain	862648-071
	For use in Switzerland	862648-BG1
	For use in Turkey	862648-141
	For use in the United Kingdom	862648-031
	For use in the United States	862648-001
	<b>Keyboard/top cover in sport purple finish</b> (includes keyboard cable, TouchPad, and TouchPad cable):	
	For use in Belgium	862652-A41
	For use in Bulgaria	862652-261
	For use in the Czech Republic and Slovakia	862652-FL1
	For use in Denmark, Finland, and Norway	862652-DH1
	For use in France	862652-051
	For use in Germany	862652-041
	For use in Greece	862652-151
	For use in Hungary	862652-211
	For use in Israel	862652-BB1
	For use in Italy	862652-061
	For use in the Netherlands	862652-B31
	For use in Portugal	862652-131
	For use in Romania	862652-271
	For use in Russia	862652-251
	For use in Saudi Arabia	862652-171
	For use in Slovenia	862652-F81
	For use in Spain	862652-071

Item	Component	Spare part number
	For use in Switzerland	862652-BG1
	For use in Turkey	862652-141
	For use in the United Kingdom	862652-031
	For use in the United States	862652-001
(3)	<b>Power button board</b> (includes cable and double-sided adhesive)	807528-001
(4)	<b>Power connector cable</b>	807522-001
(5)	<b>Connector board</b> (includes cable, memory card reader, USB port, and double-sided adhesive)	807527-001
(6)	<b>Hard drive:</b>  <b>NOTE:</b> The hard drive spare part kit does not include the hard drive bracket, cable, or screws. The hard drive bracket and screws are included in the Hard Drive Kit, spare part number 808238-001.	
	1-TB, 5400-rpm, SATA, 7.2-mm hard drive	762990-005
	500-GB, 5400-rpm, SATA, 7.0-mm hard drive	778186-005
	500-GB, 5400-rpm, SATA, 8-GB hybrid, 7.0-mm, solid-state hard drive	732000-005
(7)	<b>WLAN module:</b>	
	Intel Dual Band Wireless-AC 3168 802.11 AC 1×1 WiFi + Bluetooth 4.2 Combo Adaptor (non-vPro) (for use only on computer models with model numbers 15-bk100 through 15-bk199)	863934-005
	Intel Dual Band Wireless-AC 3165 802.11 AC 1×1 WiFi + Bluetooth 4.2 Combo Adapter (for use on all computer models)	806723-005
(8)	<b>System board</b> (includes processor and replacement thermal material):	
	For use only on computer models with model numbers 15-bk100 through 15-bk199:	
	Equipped with an Intel Core i5-7200U 2.50-GHz (SC turbo up to 3.10-GHz) processor (2133-MHz FSB, 3.0-MB L3 cache, dual core, 15-W), a graphics subsystem with UMA memory, and the Windows 10 Professional operating system	863887-601
	Equipped with an Intel Core i5-7200U 2.50-GHz (SC turbo up to 3.10-GHz) processor (2133-MHz FSB, 3.0-MB L3 cache, dual core, 15-W), a graphics subsystem with UMA, and a non-Windows operating system	863887-001
	Equipped with an Intel Core i3-7100U 2.40-GHz processor (2133-MHz FSB, 3.0-MB L3 cache, dual core, 15-W), a graphics subsystem with UMA memory, and the Windows 10 Professional operating system	863886-601
	Equipped with an Intel Core i3-7100U 2.40-GHz processor (2133-MHz FSB, 3.0-MB L3 cache, dual core, 15-W), a graphics subsystem with UMA, and a non-Windows operating system	863886-001
	For use only on computer models with model numbers 15-bk000 through 15-bk099:	
	Equipped with an Intel Core i7-6500U 2.50-GHz (SC turbo up to 3.10-GHz) processor (1600-MHz FSB, 4.0-MB L3 cache, dual core, 15-W), an nVIDIA N165-GM (GeForce 930M) graphics subsystem with 2048-MB of dedicated video memory, and the Windows 10 Professional operating system	863126-601
	Equipped with an Intel Core i7-6500U 2.50-GHz (SC turbo up to 3.10-GHz) processor (1600-MHz FSB, 4.0-MB L3 cache, dual core, 15-W), an nVIDIA N165-GM (GeForce 930M) graphics subsystem with 2048-MB of dedicated video memory, and a non-Windows operating system	863126-001

Item	Component	Spare part number
	Equipped with an Intel Core i5-6200U 2.30-GHz (5C turbo up to 2.80-GHz) processor (1600-MHz FSB, 3.0-MB L3 cache, dual core, 15-W), an nVIDIA N16S-GM (GeForce 930M) graphics subsystem with 2048-MB of dedicated video memory, and the Windows 10 Professional operating system	863125-601
	Equipped with an Intel Core i5-6200U 2.30-GHz (5C turbo up to 2.80-GHz) processor (1600-MHz FSB, 3.0-MB L3 cache, dual core, 15-W), an nVIDIA N16S-GM (GeForce 930M) graphics subsystem with 2048-MB of dedicated video memory, and a non-Windows operating system	863125-001
	Equipped with an Intel Core i5-6200U 2.30-GHz (5C turbo up to 2.80-GHz) processor (1600-MHz FSB, 3.0-MB L3 cache, dual core, 15-W), an Intel HD Graphics 520 graphics subsystem with UMA memory, and the Windows 10 Professional operating system	860593-601
	Equipped with an Intel Core i5-6200U 2.30-GHz (5C turbo up to 2.80-GHz) processor (1600-MHz FSB, 3.0-MB L3 cache, dual core, 15-W), an Intel HD Graphics 520 graphics subsystem with UMA memory, and a non-Windows operating system	860593-001
	Equipped with an Intel Core i3-6100U 2.30-GHz processor (1600-MHz FSB, 3.0-MB L3 cache, dual core, 15-W), an Intel HD Graphics 520 graphics subsystem with UMA memory, and the Windows 10 Professional operating system	860592-601
	Equipped with an Intel Core i3-6100U 2.30-GHz processor (1600-MHz FSB, 3.0-MB L3 cache, dual core, 15-W), an Intel HD Graphics 520 graphics subsystem with UMA memory, and a non-Windows operating system	860592-001
	Equipped with an Intel Pentium 4405U 2.10-GHz processor (1600-MHz FSB, 2.0-MB L3 cache, dual core, 15-W), an Intel HD Graphics 510 graphics subsystem with UMA memory, and the Windows 10 Professional operating system	860591-601
	Equipped with an Intel Pentium 4405U 2.10-GHz processor (1600-MHz FSB, 2.0-MB L3 cache, dual core, 15-W), an Intel HD Graphics 510 graphics subsystem with UMA memory, and a non-Windows operating system	860591-001
<b>(9)</b>	<b>Memory modules (2; PC3L, 12800, 1600):</b>	
	8-GB	693374-005
	4-GB	691740-005
	2-GB	691739-005
<b>(10)</b>	<b>Memory module shield</b> (The memory module shield is not available as a replacement spare part component)	
	<b>Fan/heat sink assembly</b> (includes replacement thermal material):	
<b>(11)</b>	For use only on computer models equipped with a graphics subsystem with UMA video memory	862523-001
<b>(12)</b>	For use only on computer models equipped with a graphics subsystem with discrete video memory	863970-001
<b>(13)</b>	<b>3-cell, 48-WHr, 4.2-AHr, Li-ion battery</b> (includes cable)	796356-005
<b>(14)</b>	<b>RTC battery</b> (includes cable and double-sided adhesive)	683502-001
<b>(15)</b>	<b>Speakers</b> (includes cables and four isolators)	807535-001
<b>(16)</b>	<b>Base enclosure</b> (includes front rubber feet, retention magnets, shielding, and vents)	
	In cardinal red finish	862640-001
	In natural silver finish	862639-001
	In sport purple finish	862641-001

Item	Component	Spare part number
	<b>Rubber Kit</b> (not illustrated, includes base enclosure rubber feet, screw cover strips, and screw cover plugs)	
	In cardinal red finish	862645-001
	In natural silver finish	807533-001
	In sport purple finish	862646-001

## Display components

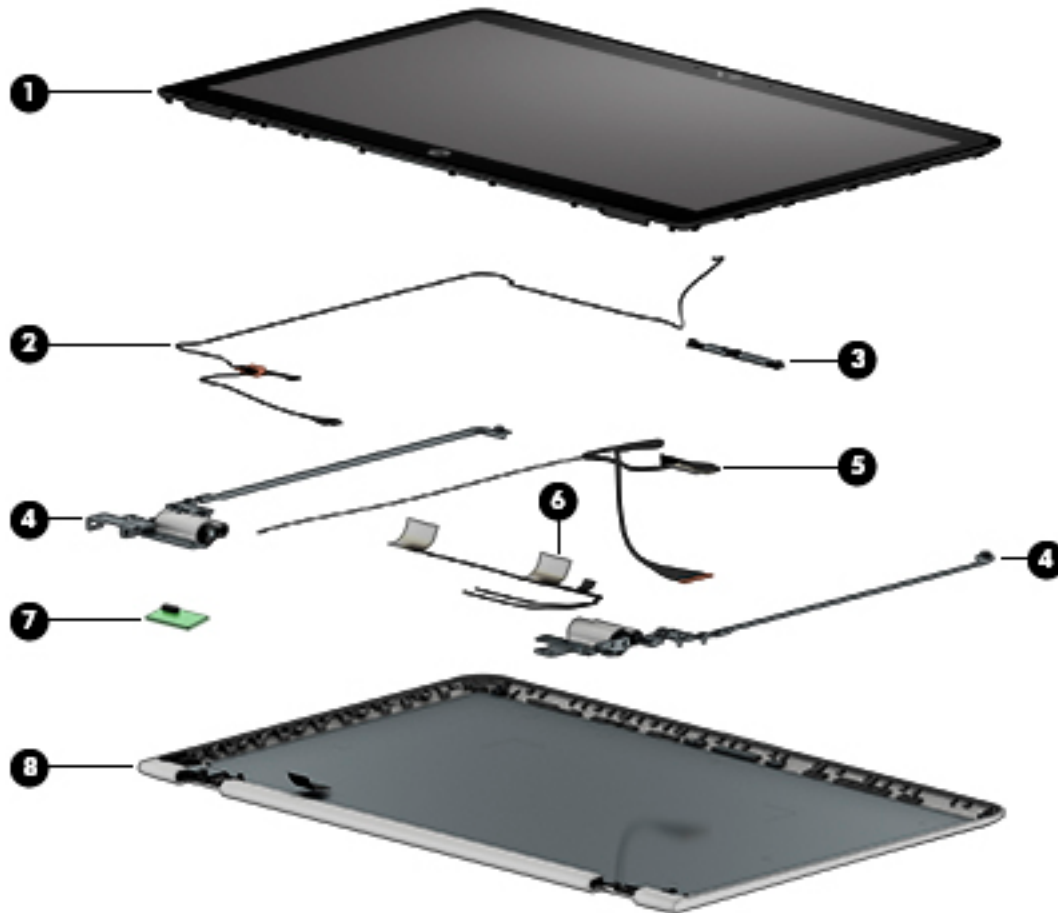

Item	Component	Spare part number
<b>(1)</b>	<b>Display panel assembly</b> (includes bezel, panel, and TouchScreen board):	
	15.6-in, FHD, WLED, AntiGlare (1920×1080), slim-flat (3.2-mm), UWVA, eDP	862643-001
	15.6-in, HD, WLED, BrightView (1366×768), slim-flat (3.2-mm), SVA, eDP	862644-001
<b>(2)</b>	<b>Webcam/microphone module</b> (includes double-sided adhesive)	756762-035
<b>(3)</b>	<b>Webcam/microphone module cable</b> (includes G-sensor board cable and double-sided adhesive):	
	For use only on computer models with model numbers 15-bk100 through 15-bk199	903912-001
	For use only on computer models with model numbers 15-bk000 through 15-bk099	807529-001

Item	Component	Spare part number
(4)	<b>Display hinges</b> (2)	862642-001
	<b>Display hinge covers</b> (2; not illustrated)	810455-001
(5)	<b>Display panel cable</b> (includes TouchScreen board cable, adhesive support strip, and double-sided adhesive):	
	For use only on computer models with model numbers 15-bk100 through 15-bk199	903913-001
	For use only on computer models with model numbers 15-bk000 through 15-bk099	808240-001
(6)	<b>Antenna Kit</b> (includes auxiliary antenna cables and transceivers and main antenna cables and transceivers)	862635-001
(7)	<b>G-sensor board</b> (includes double-sided adhesive)	807530-001
(8)	<b>Back cover:</b>	
	In cardinal red finish	862637-001
	In natural silver finish	862636-001
	In sport purple finish	862638-001

## Miscellaneous parts

Component	Spare part number
<b>AC adapter:</b>	
65-W HP Smart AC adapter (non-PFC, S-3P, 4.5-mm) for use on all computer models	710412-001
65-W HP Smart AC adapter (non-PFC, EM, 4.5-mm) for use only on computer models with model numbers 15-bk100 through 15-bk199	714635-850
45-W HP Smart AC adapter (non-PFC, RC, 4.5-mm, slim) for use on all computer models	741553-850
<b>HP 15.6-in black and red chroma sleeve</b>	853427-001
<b>HP HDMI-to-VGA adapter</b>	701943-001
<b>HP USB external DVD±RW DL SuperMulti Drive</b>	747080-001
<b>Power cord</b> (C5, 1.00-m):	
For use in Denmark on all computer models	213353-008
For use in Europe on all computer models	213350-009
For use in India only on computer models with model numbers 15-bk100 through 15-bk199	404827-003
For use in Israel on all computer models	398063-003
For use in North America on all computer models	213349-009
For use in Switzerland on all computer models	213354-008
For use in the United Kingdom and Singapore on all computer models	213351-008
<b>Power cord</b> (Option-917, 3-cord, 1.00-m, ROHS)	361240-002
<b>Screw Kit</b>	807534-001

---

# 4 Removal and replacement procedures preliminary requirements

## Tools required

You will need the following tools to complete the removal and replacement procedures:

- Case utility tool or similar plastic, flat-edged tool
- Flat-bladed screwdriver
- Magnetic screwdriver
- Phillips P00, P0, and P1 screwdrivers
- Torx T4 screwdriver

## Service considerations

The following sections include some of the considerations that you must keep in mind during disassembly and assembly procedures.



---

**NOTE:** As you remove each subassembly from the computer, place the subassembly (and all accompanying screws) away from the work area to prevent damage.

---

### Plastic parts



---

**CAUTION:** Using excessive force during disassembly and reassembly can damage plastic parts. Use care when handling the plastic

---

### Cables and connectors



---

**CAUTION:** When servicing the computer, be sure that cables are placed in their proper locations during the reassembly process. Improper cable placement can damage the computer.

---

Cables must be handled with extreme care to avoid damage. Apply only the tension required to unseat or seat the cables during removal and insertion. Handle cables by the connector whenever possible. In all cases, avoid bending, twisting, or tearing cables. Be sure that cables are routed in such a way that they cannot be caught or snagged by parts being removed or replaced. Handle flex cables with extreme care; these cables tear easily.

## Drive handling

---

**⚠ CAUTION:** Drives are fragile components that must be handled with care. To prevent damage to the computer, damage to a drive, or loss of information, observe these precautions:

Before removing or inserting a hard drive, shut down the computer. If you are unsure whether the computer is off or in Hibernation, turn the computer on, and then shut it down through the operating system.

Before handling a drive, be sure that you are discharged of static electricity. While handling a drive, avoid touching the connector.

Before removing a diskette drive or optical drive, be sure that a diskette or disc is not in the drive and be sure that the optical drive tray is closed.

Handle drives on surfaces covered with at least one inch of shock-proof foam.

Avoid dropping drives from any height onto any surface.

Avoid exposing an internal hard drive to products that have magnetic fields, such as monitors or speakers.

Avoid exposing an internal hard drive to products that have magnetic fields, such as monitors or speakers.

Avoid exposing a drive to temperature extremes or liquids.

If a drive must be mailed, place the drive in a bubble pack mailer or other suitable form of protective packaging and label the package "FRAGILE."

---



# Grounding guidelines

## Electrostatic discharge damage

Electronic components are sensitive to electrostatic discharge (ESD). Circuitry design and structure determine the degree of sensitivity. Networks built into many integrated circuits provide some protection, but in many cases, ESD contains enough power to alter device parameters or melt silicon junctions.

A discharge of static electricity from a finger or other conductor can destroy static-sensitive devices or microcircuitry. Even if the spark is neither felt nor heard, damage may have occurred.

An electronic device exposed to ESD may not be affected at all and can work perfectly throughout a normal cycle. Or the device may function normally for a while, then degrade in the internal layers, reducing its life expectancy.

**CAUTION:** To prevent damage to the computer when you are removing or installing internal components, observe these precautions:

Keep components in their electrostatic-safe containers until you are ready to install them.

Before touching an electronic component, discharge static electricity by using the guidelines described in this section.

Avoid touching pins, leads, and circuitry. Handle electronic components as little as possible.

If you remove a component, place it in an electrostatic-safe container.

The following table shows how humidity affects the electrostatic voltage levels generated by different activities.

**CAUTION:** A product can be degraded by as little as 700 V.

Typical electrostatic voltage levels			
Event	Relative humidity		
	10%	40%	55%
Walking across carpet	35,000 V	15,000 V	7,500 V
Walking across vinyl floor	12,000 V	5,000 V	3,000 V
Motions of bench worker	6,000 V	800 V	400 V
Removing DIPS from plastic tube	2,000 V	700 V	400 V
Removing DIPS from vinyl tray	11,500 V	4,000 V	2,000 V
Removing DIPS from Styrofoam	14,500 V	5,000 V	3,500 V
Removing bubble pack from PCB	26,500 V	20,000 V	7,000 V
Packing PCBs in foam-lined box	21,000 V	11,000 V	5,000 V

## Packaging and transporting guidelines

Follow these grounding guidelines when packaging and transporting equipment:

- To avoid hand contact, transport products in static-safe tubes, bags, or boxes.
- Protect ESD-sensitive parts and assemblies with conductive or approved containers or packaging.
- Keep ESD-sensitive parts in their containers until the parts arrive at static-free workstations.
- Place items on a grounded surface before removing items from their containers.
- Always be properly grounded when touching a component or assembly.
- Store reusable ESD-sensitive parts from assemblies in protective packaging or nonconductive foam.
- Use transporters and conveyors made of antistatic belts and roller bushings. Be sure that mechanized equipment used for moving materials is wired to ground and that proper materials are selected to avoid static charging. When grounding is not possible, use an ionizer to dissipate electric charges.

## Workstation guidelines

Follow these grounding workstation guidelines:

- Cover the workstation with approved static-shielding material.
- Use a wrist strap connected to a properly grounded work surface and use properly grounded tools and equipment.
- Use conductive field service tools, such as cutters, screwdrivers, and vacuums.
- When fixtures must directly contact dissipative surfaces, use fixtures made only of static safe materials.
- Keep the work area free of nonconductive materials, such as ordinary plastic assembly aids and Styrofoam.
- Handle ESD-sensitive components, parts, and assemblies by the case or PCM laminate. Handle these items only at static-free workstations.
- Avoid contact with pins, leads, or circuitry.
- Turn off power and input signals before inserting or removing connectors or test equipment.

## Equipment guidelines

Grounding equipment must include either a wrist strap or a foot strap at a grounded workstation.

- When seated, wear a wrist strap connected to a grounded system. Wrist straps are flexible straps with a minimum of one megohm  $\pm 10\%$  resistance in the ground cords. To provide proper ground, wear a strap snugly against the skin at all times. On grounded mats with banana-plug connectors, use alligator clips to connect a wrist strap.
- When standing, use foot straps and a grounded floor mat. Foot straps (heel, toe, or boot straps) can be used at standing workstations and are compatible with most types of shoes or boots. On conductive floors or dissipative floor mats, use foot straps on both feet with a minimum of one megohm resistance between the operator and ground. To be effective, the conductive must be worn in contact with the skin.

The following grounding equipment is recommended to prevent electrostatic damage:

- Antistatic tape
- Antistatic smocks, aprons, and sleeve protectors
- Conductive bins and other assembly or soldering aids
- Nonconductive foam
- Conductive computerop workstations with ground cords of one megohm resistance
- Static-dissipative tables or floor mats with hard ties to the ground
- Field service kits
- Static awareness labels
- Material-handling packages
- Nonconductive plastic bags, tubes, or boxes
- Metal tote boxes
- Electrostatic voltage levels and protective materials

The following table lists the shielding protection provided by antistatic bags and floor mats.

Material	Use	Voltage protection level
Antistatic plastics	Bags	1,500 V
Carbon-loaded plastic	Floor mats	7,500 V
Metallized laminate	Floor mats	5,000 V

# 5 Removal and replacement procedures

**CAUTION:** Components described in this chapter should only be accessed by an authorized service provider. Accessing these parts can damage the computer or void the warranty.

## Component replacement procedures

**NOTE:** Details about the computer, including model, serial number, product key, and length of warranty, are on the service tag on the back of the computer. See [Locating the model number, product number, serial number, and warranty information on page 14](#) for details.

This chapter provides removal and replacement procedures.

There are as many as 54 screws that must be removed, replaced, and/or loosened when servicing the computer. Make special note of each screw size and location during removal and replacement.

### Keyboard/top cover

For use in country	Spare part number	For use in country	Spare part number
Keyboard/top cover with backlight (includes backlight cable, keyboard cable, TouchPad, and TouchPad cable):		In natural silver finish for use in the United States	862647-001
In cardinal red finish for use in the United States	862649-001	In sport purple finish for use in the United States	862651-001
Keyboard/top cover in cardinal red finish (includes keyboard cable, TouchPad, and TouchPad cable):		For use in the Netherlands	862650-B31
For use in Belgium	862650-A41	For use in Portugal	862650-131
For use in Bulgaria	862650-261	For use in Romania	862650-271
For use in the Czech Republic and Slovakia	862650-FL1	For use in Russia	862650-251
For use in Denmark, Finland, and Norway	862650-DH1	For use in Saudi Arabia	862650-171
For use in France	862650-051	For use in Slovenia	862650-F81
For use in Germany	862650-041	For use in Spain	862650-071
For use in Greece	862650-151	For use in Switzerland	862650-BG1
For use in Hungary	862650-211	For use in Turkey	862650-141
For use in Israel	862650-BB1	For use in the United Kingdom	862650-031
For use in Italy	862650-061	For use in the United States	862650-001
Keyboard/top cover in natural silver finish (includes keyboard cable, TouchPad, and TouchPad cable):		For use in the Netherlands	862648-B31
For use in Belgium	862648-A41	For use in Portugal	862648-131
For use in Bulgaria	862648-261	For use in Romania	862648-271

For use in country	Spare part number	For use in country	Spare part number
For use in the Czech Republic and Slovakia	862648-FL1	For use in Russia	862648-251
For use in Denmark, Finland, and Norway	862648-DH1	For use in Saudi Arabia	862648-171
For use in France	862648-051	For use in Slovenia	862648-F81
For use in Germany	862648-041	For use in Spain	862648-071
For use in Greece	862648-151	For use in Switzerland	862648-BG1
For use in Hungary	862648-211	For use in Turkey	862648-141
For use in Israel	862648-BB1	For use in the United Kingdom	862648-031
For use in Italy	862648-061	For use in the United States	862648-001
Keyboard/top cover in natural silver finish (includes keyboard cable, TouchPad, and TouchPad cable):		For use in the Netherlands	862648-B31
For use in Belgium	862648-A41	For use in Portugal	862648-131
For use in Bulgaria	862648-261	For use in Romania	862648-271
For use in the Czech Republic and Slovakia	862648-FL1	For use in Russia	862648-251
For use in Denmark, Finland, and Norway	862648-DH1	For use in Saudi Arabia	862648-171
For use in France	862648-051	For use in Slovenia	862648-F81
For use in Germany	862648-041	For use in Spain	862648-071
For use in Greece	862648-151	For use in Switzerland	862648-BG1
For use in Hungary	862648-211	For use in Turkey	862648-141
For use in Israel	862648-BB1	For use in the United Kingdom	862648-031
For use in Italy	862648-061	For use in the United States	862648-001

Before disassembling the computer, follow these steps:

1. Turn off the computer. If you are unsure whether the computer is off or in Hibernation, turn the computer on, and then shut it down through the operating system.
2. Disconnect the power from the computer by unplugging the power cord from the computer.
3. Disconnect all external devices from the computer.

Remove the keyboard/top cover:

1. Close the computer.
2. Turn the computer upside down with the front toward you.
3. Remove the four computer feet **(1)**.
4. Remove the two screw cover strips **(2)**.

5. Remove the two screw cover plugs (3).

The computer feet, screw cover strips, and screw cover plugs are included in the Rubber Kits, using the following spare part numbers:

- 862645-001 – In cardinal red finish
- 807533-001 – In natural silver finish
- 862646-001 – in sport purple finish

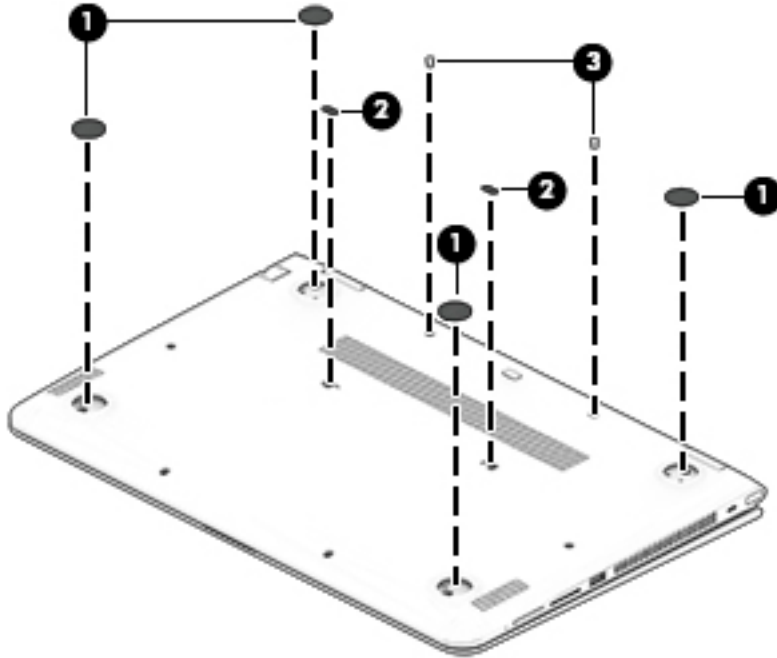

6. Remove the twelve Phillips M2.5×7.0 screws that secure the keyboard/top cover to the computer.

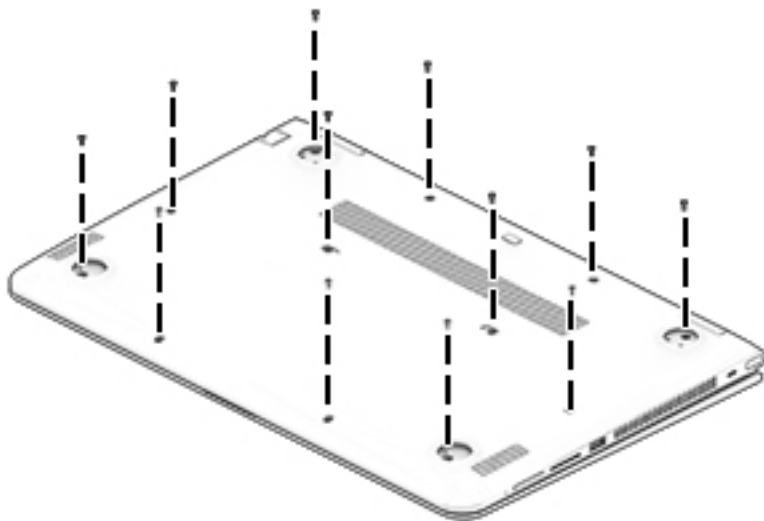

7. Turn the computer right side up with the front toward you.

8. Open the computer.

9. Insert a case utility tool **(1)** or similar plastic, flat-edged tool between the keyboard/top cover and the computer near the display hinge area.
10. Release the keyboard/top cover **(2)** by lifting the rear edge up and forward.

---

**⚠ CAUTION:** Before lifting the front edge of the keyboard/top cover and detaching it from the base enclosure, be aware that the backlight cable, keyboard cable, and TouchPad cable are still connected to the system board. The keyboard/top cover should only be moved as far as these cables allow. Failure to follow this caution can result in damage to these cables and their main components.

---

11. Remove the keyboard/top cover **(3)** by lifting the front edge as far as the backlight cable, keyboard cable, and TouchPad cable allow.

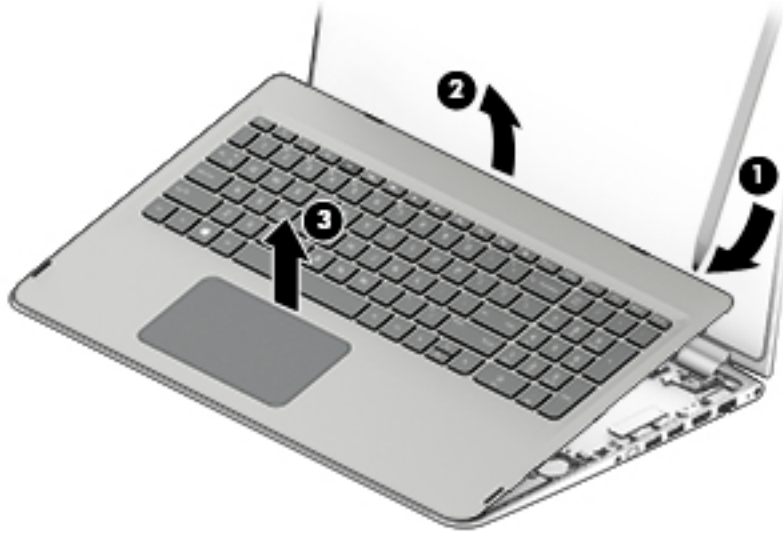

12. Lift the front edge of the keyboard/top cover **(1)** until the backlight cable, keyboard cable, and TouchPad cable are accessible.
13. Release the zero insertion force (ZIF) connector **(2)** to which the TouchPad cable is connected, and then disconnect the TouchPad cable from the system board.
14. Release the ZIF connector **(3)** to which the keyboard cable is connected, and then disconnect the keyboard cable from the system board.

15. Release the ZIF connector **(4)** to which the backlight cable is connected, and then disconnect the backlight cable from the system board.

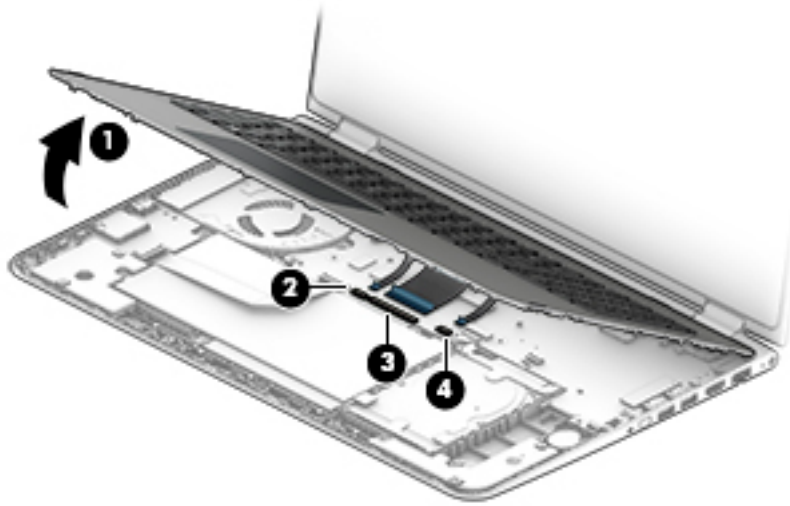

16. Remove the keyboard/top cover.  
Reverse this procedure to install the keyboard/top cover.



## Battery

Description	Spare part number
3-cell, 48-WHr, 4.2-AHr, Li-ion battery (includes cable)	796356-005

Before removing the battery, follow these steps:

1. Turn off the computer. If you are unsure whether the computer is off or in Hibernation, turn the computer on, and then shut it down through the operating system.
2. Disconnect the power from the computer by unplugging the power cord from the computer.
3. Disconnect all external devices from the computer.
4. Remove the keyboard/top cover (see [Keyboard/top cover on page 28](#)).

Remove the battery:

1. Disconnect the battery cable **(1)** from the system board.
2. Remove the four Phillips M2.5×4.4 screws **(2)** that secure the battery to the base enclosure.
3. Detach the card reader board cable **(3)** from the battery. (The card reader board cable is attached to the battery with double-sided adhesive.)
4. Use a case utility tool **(4)** or similar plastic, flat-edged tool to lift the right side of the battery until it rests at an angle.
5. Remove the battery **(5)** by sliding it up and to the right at an angle.

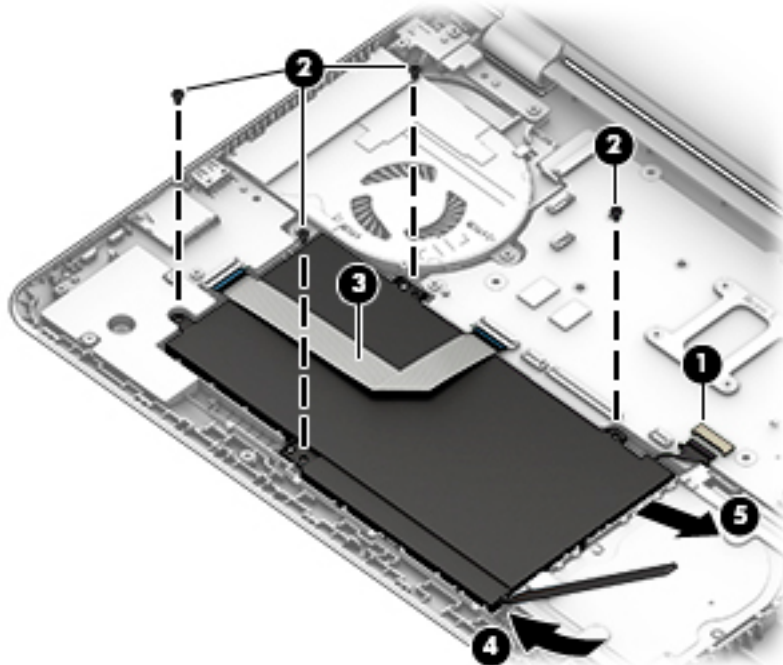

Reverse this procedure to install the battery.

## Speakers

Description	Spare part number
Speakers (includes cables and four isolators)	807535-001

Before removing the speakers, follow these steps:

1. Turn off the computer. If you are unsure whether the computer is off or in Hibernation, turn the computer on, and then shut it down through the operating system.
2. Disconnect the power from the computer by unplugging the power cord from the computer.
3. Disconnect all external devices from the computer.
4. Remove the keyboard/top cover (see [Keyboard/top cover on page 28](#)).
5. Disconnect the battery cable from the system board (see [Battery on page 33](#)).

Remove the speakers:

1. Disconnect the speaker cable **(1)** from the system board.
2. Release the speaker cables from the routing clips **(2)** and channel built into the base enclosure.
3. Remove the four Phillips PM2.5×5.5 shoulder screws **(3)** that secure the speakers to the base enclosure.
4. Remove the speakers **(4)**.

 **NOTE:** When removing the speakers, make note of the location of the four rubber isolators **(5)**. Failure to properly install or damage to these isolators can result in degraded speaker performance.

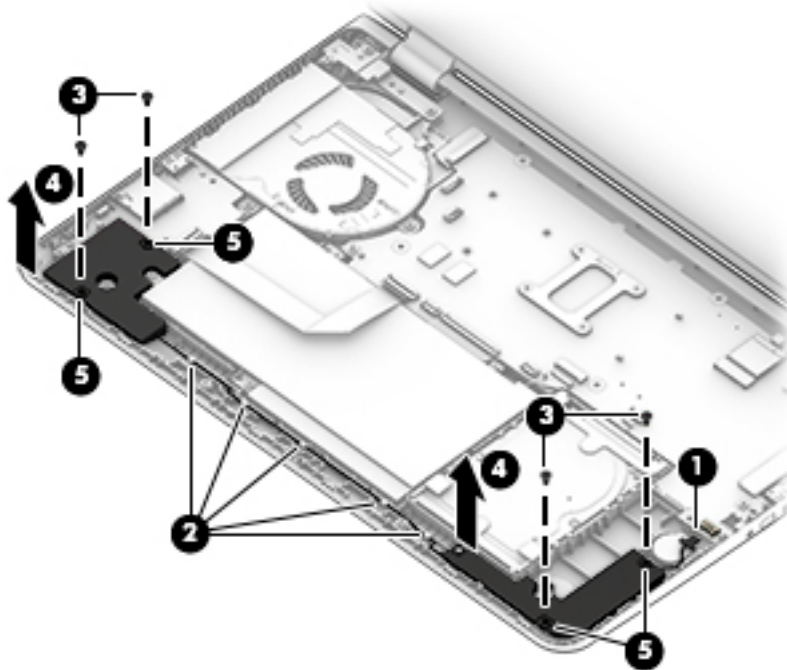

Reverse this procedure to install the speakers.

## Hard drive



**NOTE:** The hard drive spare part kit does not include the hard drive bracket or cable. The hard drive bracket and cable are included in the Hard Drive Kit, spare part number 808238-001.

Description	Spare part number
1-TB, 5400-rpm, SATA, 7.2-mm hard drive	762990-005
500-GB, 5400-rpm, SATA, 7.0-mm hard drive	778186-005
500-GB, 5400-rpm, SATA, 8-GB hybrid, 7.0-mm, solid-state hard drive	732000-005

Before removing the hard drive, follow these steps:

1. Turn off the computer. If you are unsure whether the computer is off or in Hibernation, turn the computer on, and then shut it down through the operating system.
2. Disconnect the power from the computer by unplugging the power cord from the computer.
3. Disconnect all external devices from the computer.
4. Remove the keyboard/top cover (see [Keyboard/top cover on page 28](#)).
5. Disconnect the battery cable from the system board (see [Battery on page 33](#)).

Remove the hard drive:

1. Release the ZIF connector **(1)** to which the hard drive cable is connected, and then disconnect the hard drive cable from the system board.
2. Use the tab **(2)** to lift the front edge of the hard drive **(3)** until it rests at an angle.
3. Remove the hard drive **(4)** by sliding it up and forward at an angle.

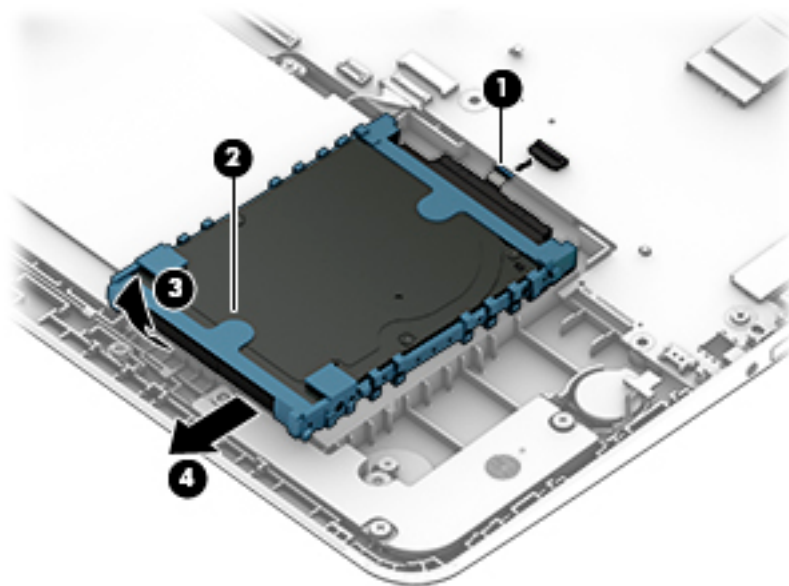

4. If it is necessary to replace the hard drive bracket, separate the left and right sides of the bracket **(1)** from the hard drive, and then remove the hard drive bracket **(2)**.

5. If it is necessary to replace the hard drive cable, detach the cable **(3)** from the front end of the hard drive.

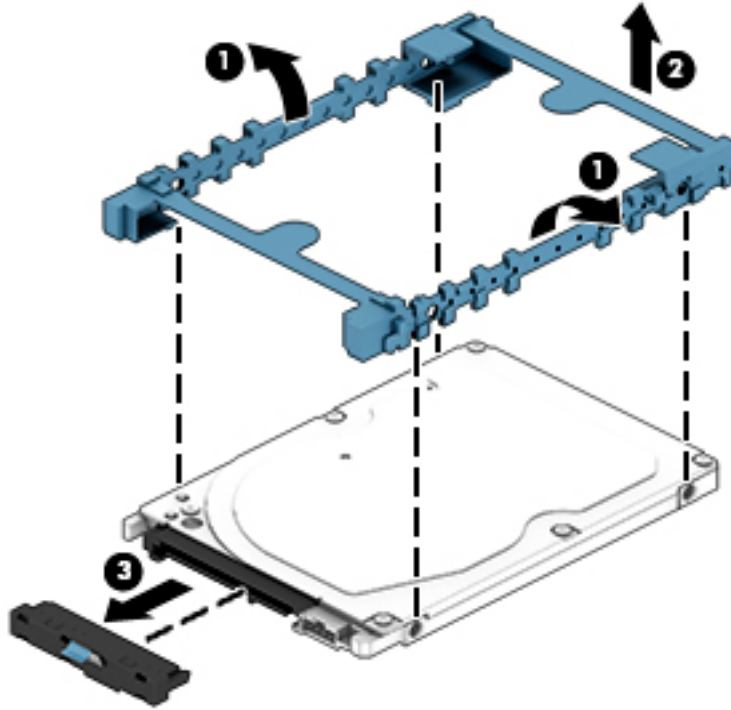

Reverse this procedure to reassemble and install the hard drive.

## RTC battery

Description	Spare part number
RTC battery (includes cable and double-sided adhesive)	683502-001

Before removing the TouchPad cable, follow these steps:

1. Turn off the computer. If you are unsure whether the computer is off or in Hibernation, turn the computer on, and then shut it down through the operating system.
2. Disconnect the power from the computer by unplugging the power cord from the computer.
3. Disconnect all external devices from the computer.
4. Remove the keyboard/top cover (see [Keyboard/top cover on page 28](#)).
5. Remove the battery (see [Battery on page 33](#)).

Remove the RTC battery:

1. Disconnect the RTC battery cable **(1)** from the system board.

2. Detach the RTC battery (2) from the base enclosure. (The RTC battery cable is secured to the base enclosure with double-sided adhesive.)

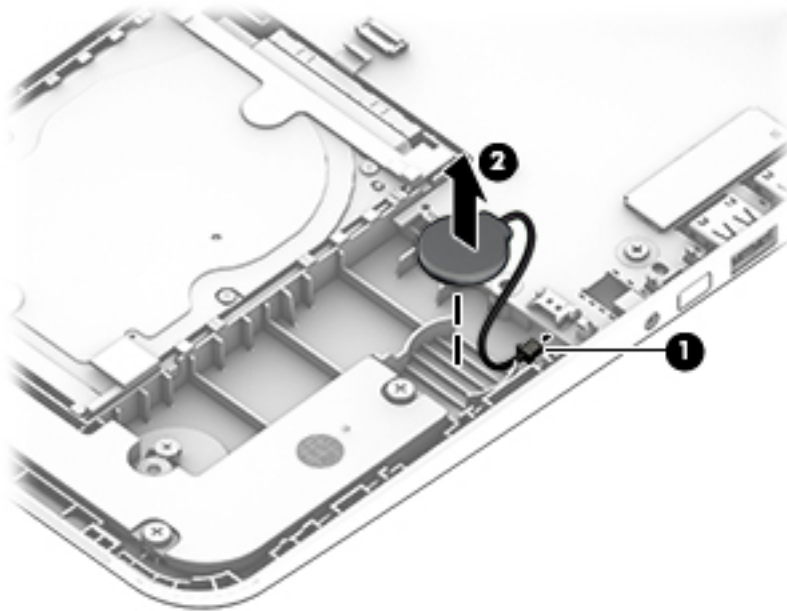

3. Remove the RTC battery.

Reverse this procedure to install the RTC battery.

## WLAN module

Description	Spare part number
Intel Dual Band Wireless-AC 3168 802.11 AC 1×1 WiFi + Bluetooth 4.2 Combo Adaptor (non-vPro) (for use only on computer models with model numbers 15-bk100 through 15-bk199)	863934-005
Intel Dual Band Wireless-AC 3165 802.11 AC 1×1 WiFi + Bluetooth 4.2 Combo Adapter (for use on all computer models)	806723-005

**CAUTION:** To prevent an unresponsive system, replace the wireless module only with a wireless module authorized for use in the computer by the governmental agency that regulates wireless devices in your country or region. If you replace the module and then receive a warning message, remove the module to restore device functionality, and then contact technical support.

Before removing the WLAN module, follow these steps:

1. Turn off the computer. If you are unsure whether the computer is off or in Hibernation, turn the computer on, and then shut it down through the operating system.
2. Disconnect the power from the computer by unplugging the power cord from the computer.
3. Disconnect all external devices from the computer.
4. Remove the base enclosure (see [Keyboard/top cover on page 28](#)).
5. Disconnect the battery cable from the system board (see [Battery on page 33](#)).

Remove the WLAN module:

1. Disconnect the WLAN antenna cables **(1)** from the terminals on the WLAN module.

---

 **NOTE:** The WLAN antenna cable labeled “1/MAIN” connects to the WLAN module “Main” terminal. The WLAN antenna cable labeled “2/AUX” connects to the WLAN module “Aux” terminal.

---

2. Remove the grounding pad **(2)** that covers the WLAN retention screw.
3. Remove the Phillips PM2.0×3.3 screw **(3)** that secures the WLAN module to the computer.
4. Release the WLAN module **(4)** by lifting the rear edge of the module until it rests at an angle.
5. Remove the WLAN module **(5)** by pulling the module away from the slot at an angle.

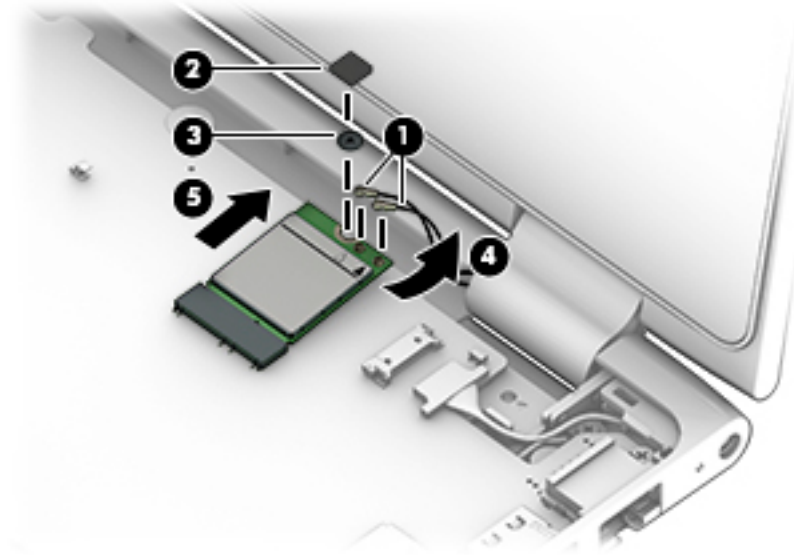

---

 **NOTE:** If the WLAN antenna cables are not connected to the WLAN module terminal, the protective sleeves should be installed on the antenna connectors, as shown in the following illustration.

---

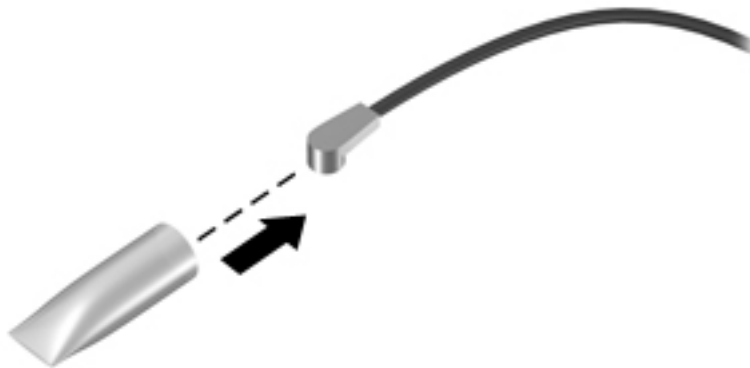

Reverse this procedure to install the WLAN module.

## Connector board

Description	Spare part number
Connector board (includes cable, memory card reader, USB port, and double-sided adhesive)	807527-001

Before removing the connector board, follow these steps:

1. Turn off the computer. If you are unsure whether the computer is off or in Hibernation, turn the computer on, and then shut it down through the operating system.
2. Disconnect the power from the computer by unplugging the power cord from the computer.
3. Disconnect all external devices from the computer.
4. Remove the base enclosure (see [Keyboard/top cover on page 28](#)).
5. Remove the base enclosure (see [Keyboard/top cover on page 28](#)).
6. Disconnect the battery cable from the system board (see [Battery on page 33](#)).

Remove the connector board:

1. Release the ZIF connector **(1)** to which the connector board cable is connected, and then disconnect the connector board cable from the system board.
2. Detach the connector board cable **(2)** from the battery. (The connector board cable is attached to the battery with double-sided adhesive.)
3. Remove the two Phillips PM2.0×3.3 screws **(3)** that secure the connector board to the base enclosure.
4. Remove the connector board **(4)**.

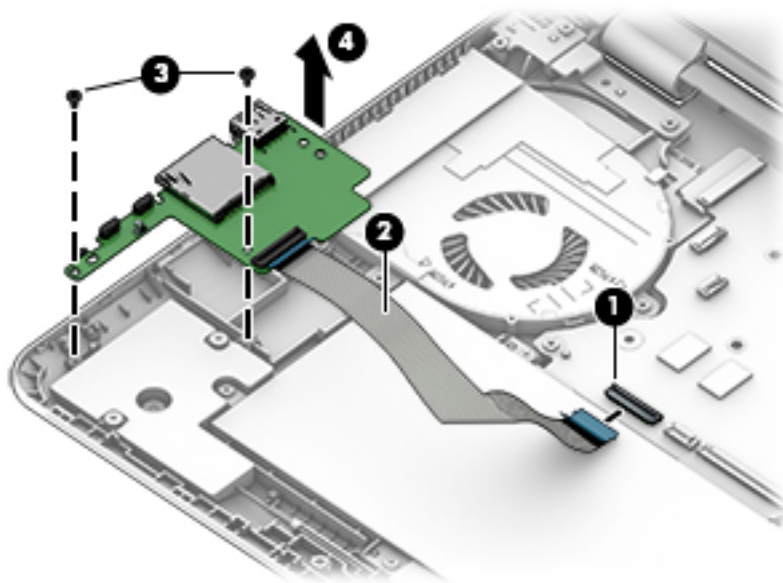

Reverse this procedure to install the connector board.

## System board

Description	Spare part number
For use only on computer models with model numbers 15-bk100 through 15-bk199:	
Equipped with an Intel Core i5-7200U 2.50-GHz (SC turbo up to 3.10-GHz) processor (2133-MHz FSB, 3.0-MB L3 cache, dual core, 15-W), a graphics subsystem with UMA memory, and the Windows 10 Professional operating system	863887-601
Equipped with an Intel Core i5-7200U 2.50-GHz (SC turbo up to 3.10-GHz) processor (2133-MHz FSB, 3.0-MB L3 cache, dual core, 15-W), a graphics subsystem with UMA, and a non-Windows operating system	863887-001
Equipped with an Intel Core i3-7100U 2.40-GHz processor (2133-MHz FSB, 3.0-MB L3 cache, dual core, 15-W), a graphics subsystem with UMA memory, and the Windows 10 Professional operating system	863886-601
Equipped with an Intel Core i3-7100U 2.40-GHz processor (2133-MHz FSB, 3.0-MB L3 cache, dual core, 15-W), a graphics subsystem with UMA, and a non-Windows operating system	863886-001
For use only on computer models with model numbers 15-bk000 through 15-bk099:	
Equipped with an Intel Core i7-6500U 2.50-GHz (SC turbo up to 3.10-GHz) processor (1600-MHz FSB, 4.0-MB L3 cache, dual core, 15-W), an nVIDIA N16S-GM (GeForce 930M) graphics subsystem with 2048-MB of dedicated video memory, and the Windows 10 Professional operating system	863126-601
Equipped with an Intel Core i7-6500U 2.50-GHz (SC turbo up to 3.10-GHz) processor (1600-MHz FSB, 4.0-MB L3 cache, dual core, 15-W), an nVIDIA N16S-GM (GeForce 930M) graphics subsystem with 2048-MB of dedicated video memory, and a non-Windows operating system	863126-001
Equipped with an Intel Core i5-6200U 2.30-GHz (SC turbo up to 2.80-GHz) processor (1600-MHz FSB, 3.0-MB L3 cache, dual core, 15-W), an nVIDIA N16S-GM (GeForce 930M) graphics subsystem with 2048-MB of dedicated video memory, and the Windows 10 Professional operating system	863125-601
Equipped with an Intel Core i5-6200U 2.30-GHz (SC turbo up to 2.80-GHz) processor (1600-MHz FSB, 3.0-MB L3 cache, dual core, 15-W), an nVIDIA N16S-GM (GeForce 930M) graphics subsystem with 2048-MB of dedicated video memory, and a non-Windows operating system	863125-001
Equipped with an Intel Core i5-6200U 2.30-GHz (SC turbo up to 2.80-GHz) processor (1600-MHz FSB, 3.0-MB L3 cache, dual core, 15-W), an Intel HD Graphics 520 graphics subsystem with UMA memory, and the Windows 10 Professional operating system	860593-601
Equipped with an Intel Core i5-6200U 2.30-GHz (SC turbo up to 2.80-GHz) processor (1600-MHz FSB, 3.0-MB L3 cache, dual core, 15-W), an Intel HD Graphics 520 graphics subsystem with UMA memory, and a non-Windows operating system	860593-001
Equipped with an Intel Core i3-6100U 2.30-GHz processor (1600-MHz FSB, 3.0-MB L3 cache, dual core, 15-W), an Intel HD Graphics 520 graphics subsystem with UMA memory, and the Windows 10 Professional operating system	860592-601
Equipped with an Intel Core i3-6100U 2.30-GHz processor (1600-MHz FSB, 3.0-MB L3 cache, dual core, 15-W), an Intel HD Graphics 520 graphics subsystem with UMA memory, and a non-Windows operating system	860592-001
Equipped with an Intel Pentium 4405U 2.10-GHz processor (1600-MHz FSB, 2.0-MB L3 cache, dual core, 15-W), an Intel HD Graphics 510 graphics subsystem with UMA memory, and the Windows 10 Professional operating system	860591-601
Equipped with an Intel Pentium 4405U 2.10-GHz processor (1600-MHz FSB, 2.0-MB L3 cache, dual core, 15-W), an Intel HD Graphics 510 graphics subsystem with UMA memory, and a non-Windows operating system	860591-001

Before removing the system board, follow these steps:



1. Turn off the computer. If you are unsure whether the computer is off or in Hibernation, turn the computer on, and then shut it down through the operating system.
2. Disconnect the power from the computer by unplugging the power cord from the computer.
3. Disconnect all external devices from the computer.
4. Remove the base enclosure (see [Keyboard/top cover on page 28](#)).
5. Disconnect the battery cable from the system board (see [Battery on page 33](#)).
6. Disconnect the WLAN module antenna cables from the WLAN module (see [WLAN module on page 37](#)).



**NOTE:** When replacing the system board, be sure that the following components are removed from the defective system board and installed on the replacement system board.

- Memory module (see [Memory module on page 47](#))
- WLAN module (see [WLAN module on page 37](#))
- Fan/heat sink assembly (see [Fan/heat sink assembly on page 44](#))

Remove the system board:

1. Release the ZIF connector **(1)** to which the display panel cable is connected, and then disconnect the display panel cable from the system board.
2. Detach the display panel cable **(2)** from the system board. (The display panel cable is attached to the system board with double-sided adhesive.)
3. Release the ZIF connector **(3)** to which the webcam/microphone module cable is connected, and then disconnect the webcam/microphone module cable from the system board.
4. Detach the grounding tape **(4)** that secures the webcam/microphone module cable to the system board.
5. Release the ZIF connector **(5)** to which the power button board cable is connected, and then disconnect the power button board cable from the system board.
6. Detach the power button board cable **(6)** from the fan. (The power button board cable is attached to the fan with double-sided adhesive.)
7. Release the ZIF connector **(7)** to which the connector board cable is connected, and then disconnect the connector board cable from the system board.
8. Release the ZIF connector **(8)** to which the hard drive cable is connected, and then disconnect the hard drive cable from the system board.
9. Disconnect the speaker cable **(9)** from the system board.
10. Disconnect the RTC battery cable **(10)** from the system board.

11. Disconnect the the power connector cable (**11**) from the system board.

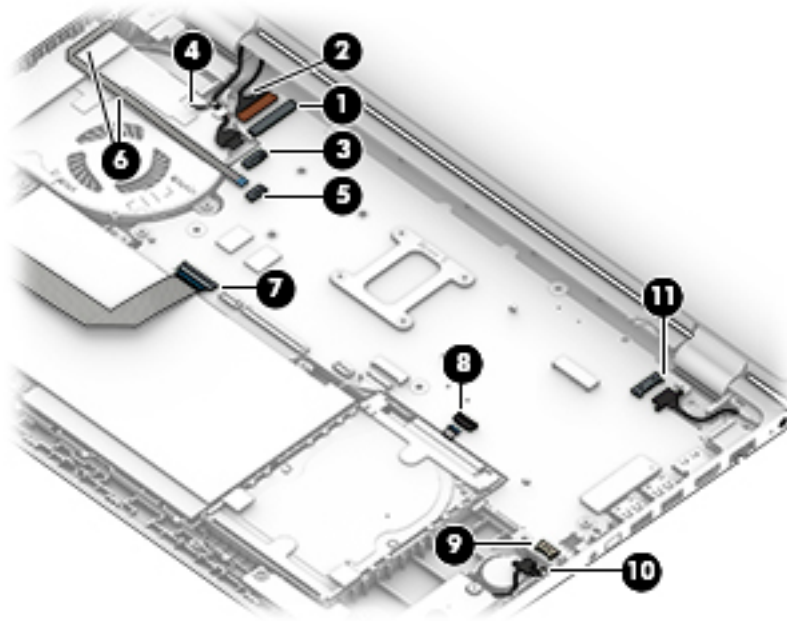

12. Remove the five Phillips PM2.5×4.4 screws that secure the system board to the base enclosure.

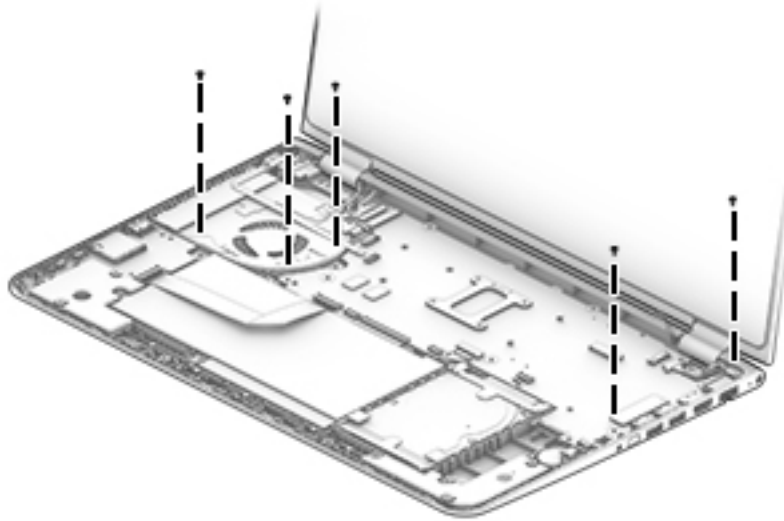

13. Lift the left side of the system board (**1**) until it rests at an angle.

14. Remove the system board (2) by sliding it up and to the left at an angle.

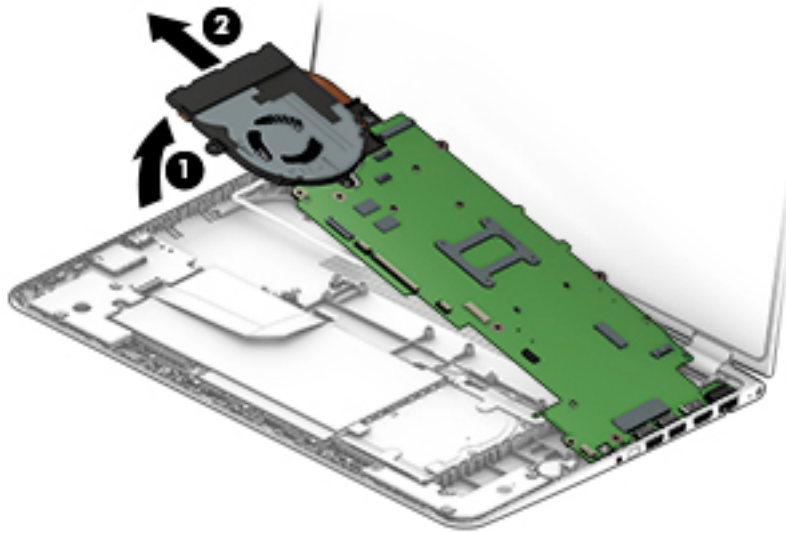

Reverse this procedure to install the system board.

## Fan/heat sink assembly

Description	Spare part number
For use only on computer models equipped with a graphics subsystem with discrete video memory	863970-001
For use only on computer models equipped with a graphics subsystem with UMA video memory	862523-001

Before removing the fan/heat sink assembly, follow these steps:

1. Turn off the computer. If you are unsure whether the computer is off or in Hibernation, turn the computer on, and then shut it down through the operating system.
2. Disconnect the power from the computer by unplugging the power cord from the computer.
3. Disconnect all external devices from the computer.
4. Remove the base enclosure (see [Keyboard/top cover on page 28](#)).
5. Disconnect the battery cable from the system board (see [Battery on page 33](#)).
6. Disconnect the WLAN module antenna cables from the WLAN module (see [WLAN module on page 37](#)).
7. Remove the system board (see [System board on page 40](#)).

Remove the fan/heat sink assembly:

1. Turn the system board upside down with the front toward you.
2. Disconnect the fan cable **(1)** from the system board.



**NOTE:** The number of screws used to secure the fan/heat sink assembly to the system board varies by computer model. Computer models equipped with a graphics subsystem with discrete memory require eight screws. Computer models equipped with a graphics subsystem with UMA memory require four screws.

3. Loosen the seven or four Phillips PM2.0×6.5 captive screws **(2)** that secure the fan/heat sink assembly to the system board.

4. Remove the fan/heat sink assembly (3).

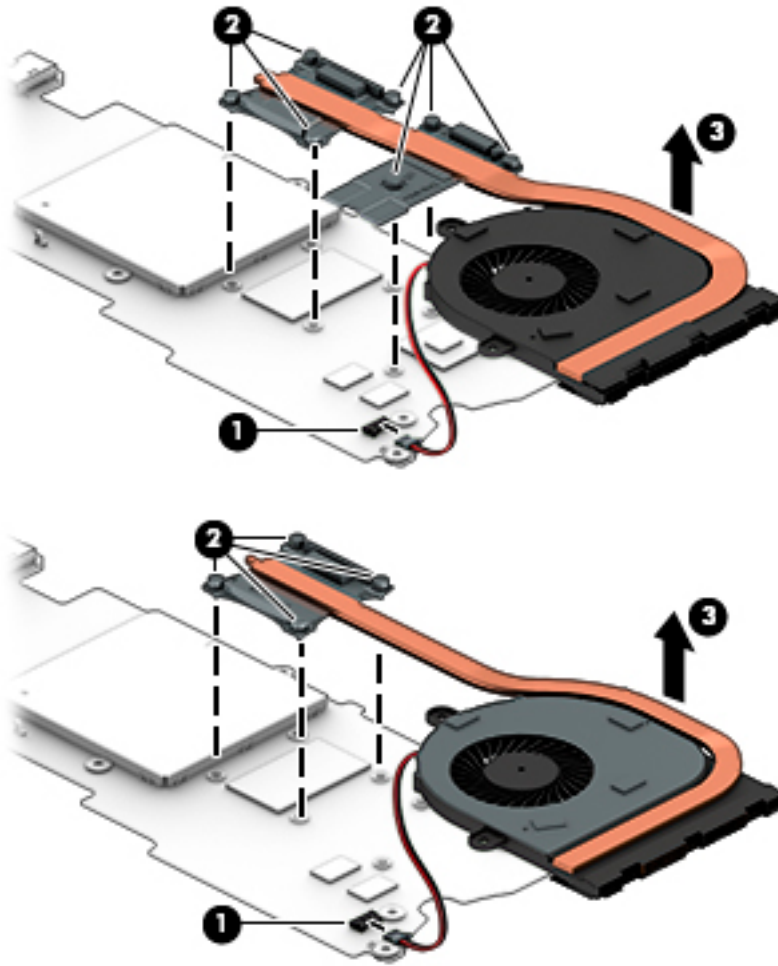

 **NOTE:** The thermal material must be thoroughly cleaned from the surfaces of the fan/heat sink assembly and the system board each time the fan/heat sink assembly is removed.

Thermal material is used on the processor (1) and the heat sink section (2) that services it. Thermal material is also used on the graphics subsystem chip (3) and the heat sink section (4) that services it. The following illustration shows the thermal material locations on a computer model equipped with a graphics subsystem with discrete memory.

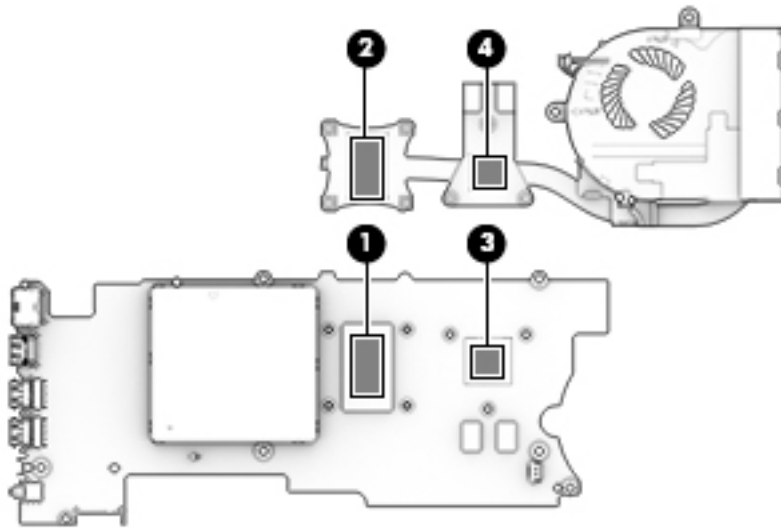

 **NOTE:** Thermal material is used on the processor **(1)** and the heat sink section **(2)** that services it. The following illustration shows the thermal material locations on a computer model equipped with a graphics subsystem with UMA memory.

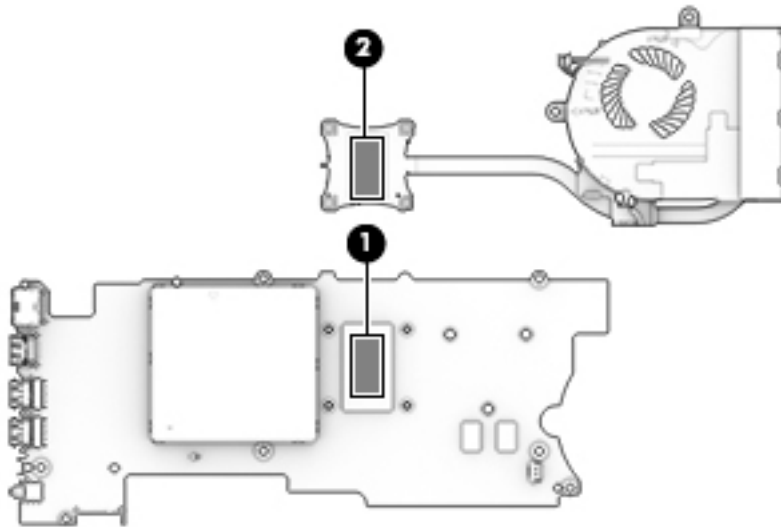

Reverse this procedure to install the fan/heat sink assembly.

## Memory module

Description	Spare part number
8-GB (PC3L, 12800, 1600)	693374-005
4-GB (PC3L, 12800, 1600)	691740-005
2-GB (PC3L, 12800, 1600)	691739-005

Before removing a memory module, follow these steps:

1. Turn off the computer. If you are unsure whether the computer is off or in Hibernation, turn the computer on, and then shut it down through the operating system.
2. Disconnect the power from the computer by unplugging the power cord from the computer.
3. Disconnect all external devices from the computer.
4. Remove the base enclosure (see [Keyboard/top cover on page 28](#)).
5. Disconnect the battery cable from the system board (see [Battery on page 33](#)).
6. Disconnect the WLAN module antenna cables from the WLAN module (see [WLAN module on page 37](#)).
7. Remove the system board (see [System board on page 40](#)).

Remove the memory module:

1. Turn the system board upside down with the front toward you.
2. Remove the memory module shield.

The memory module shield is not available as a replacement spare part component.

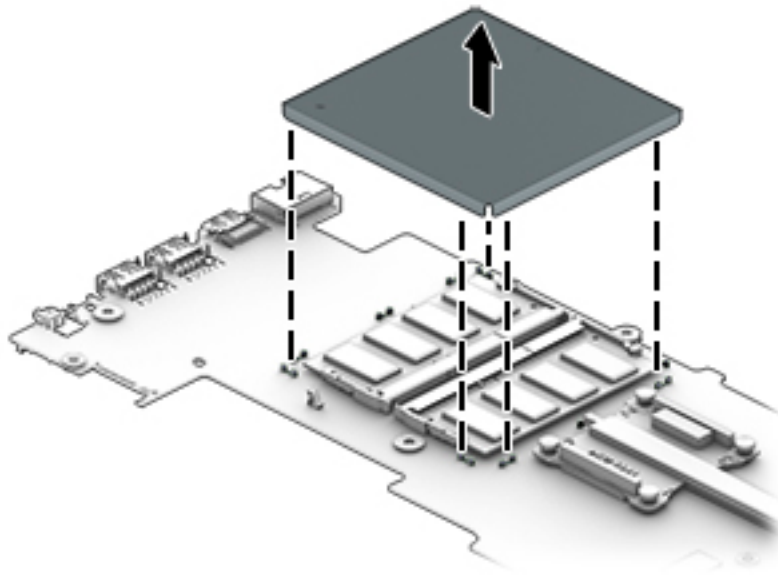

3. Spread the retaining tabs **(1)** on each side of the memory module slot to release the memory module. (The memory module tilts up.)

4. Remove the memory module **(2)** by pulling it away from the slot at an angle.

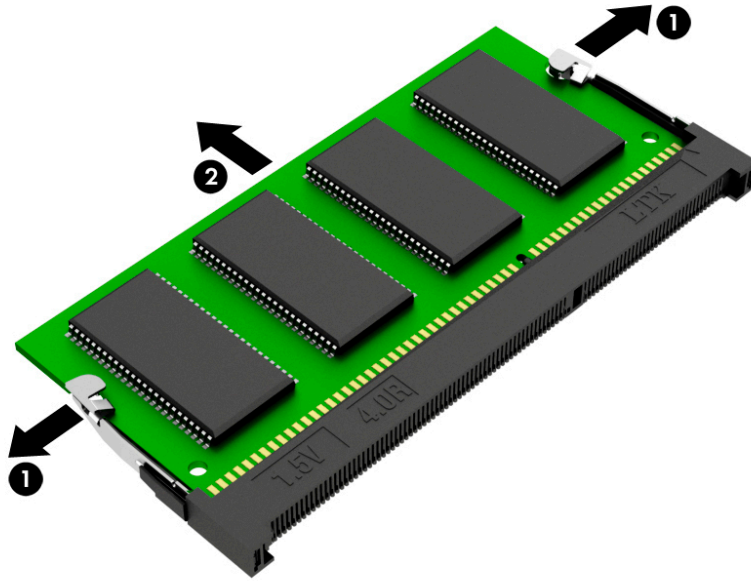

Reverse this procedure to install a memory module.

## Display assembly

 **NOTE:** The display assembly is spared at the subcomponent level only. For display assembly spare part information, see the individual removal subsections.

Before removing the display assembly, follow these steps:

1. Turn off the computer. If you are unsure whether the computer is off or in Hibernation, turn the computer on, and then shut it down through the operating system.
2. Disconnect the power from the computer by unplugging the power cord from the computer.
3. Disconnect all external devices from the computer.
4. Remove the base enclosure (see [Keyboard/top cover on page 28](#)).
5. Disconnect the battery cable from the system board (see [Battery on page 33](#)).
6. Disconnect the WLAN module antenna cables from the WLAN module (see [WLAN module on page 37](#)).
7. Remove the system board (see [System board on page 40](#)).

Remove the display assembly:

1. Remove the five Phillips PM2.5×4.4 screws **(1)** and the Phillips PM2.0×3.3 screw **(2)** that secure the display assembly to the base enclosure.



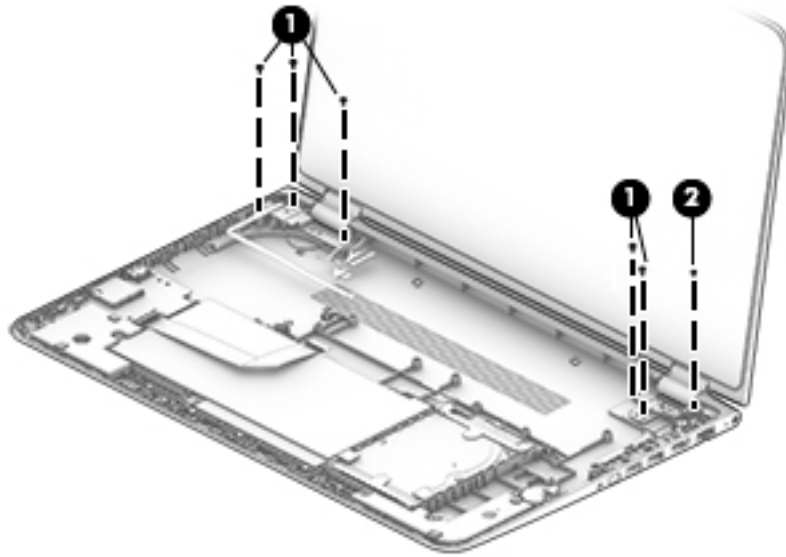

2. Release the display panel cable **(1)** and the wireless antenna cables **(2)** from the retention clips built into the base enclosure.
3. Swing the top edge of the display assembly **(3)** back until the display hinges disengage from the retention pins built into the base enclosure.
4. Slide the display assembly **(4)** forward and separate it from the base enclosure.



5. If it is necessary to replace the display panel assembly:

- a. Use a case utility tool or similar plastic, flat-edged tool to separate the top corners **(1)** of the display panel assembly from the display back cover.
- b. Lift the top edge **(2)** of the display panel assembly up and forward until the display panel assembly completely detaches from the display back cover.

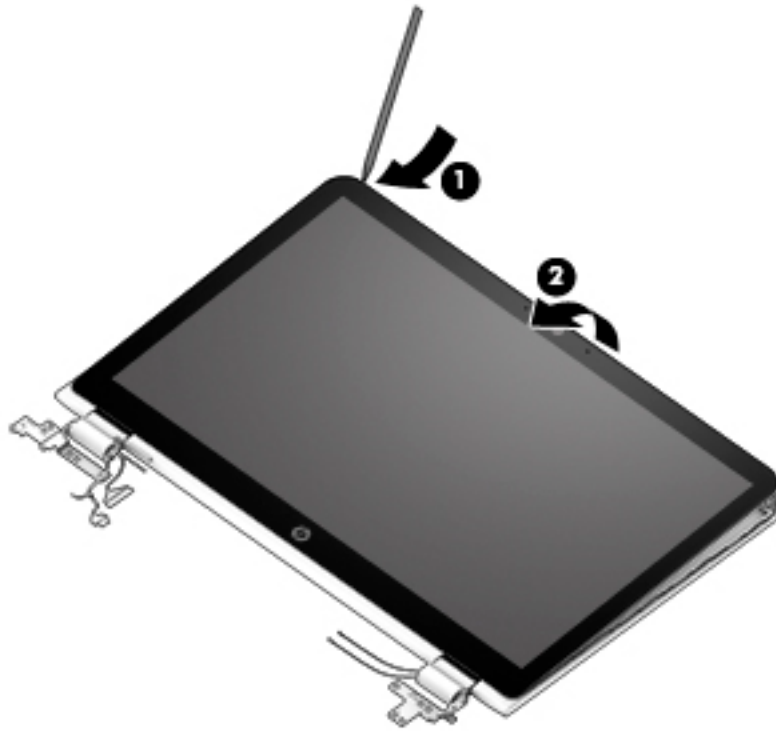

---

**⚠ CAUTION:** Before turning the display panel assembly upside down, make sure the work surface is clear of tools, screws, and any other foreign objects. Failure to follow this caution can result in damage to the display panel assembly.

---

- c. Swing the top edge **(1)** of the display panel assembly up and forward until the display panel assembly rests upside down in front of the display back cover.
- d. Release the adhesive support strip **(2)** that secures the display panel cable connector to the TouchScreen board.
- e. Disconnect the display panel cable **(3)** from the TouchScreen board.
- f. Detach the display panel cable **(4)** from the display panel. (The display panel cable is attached to the display panel with double-sided adhesive.)
- g. Release the adhesive support strip **(5)** that secures the display panel cable connector to the display panel.

- h.** Disconnect the display panel cable **(6)** from the display panel.

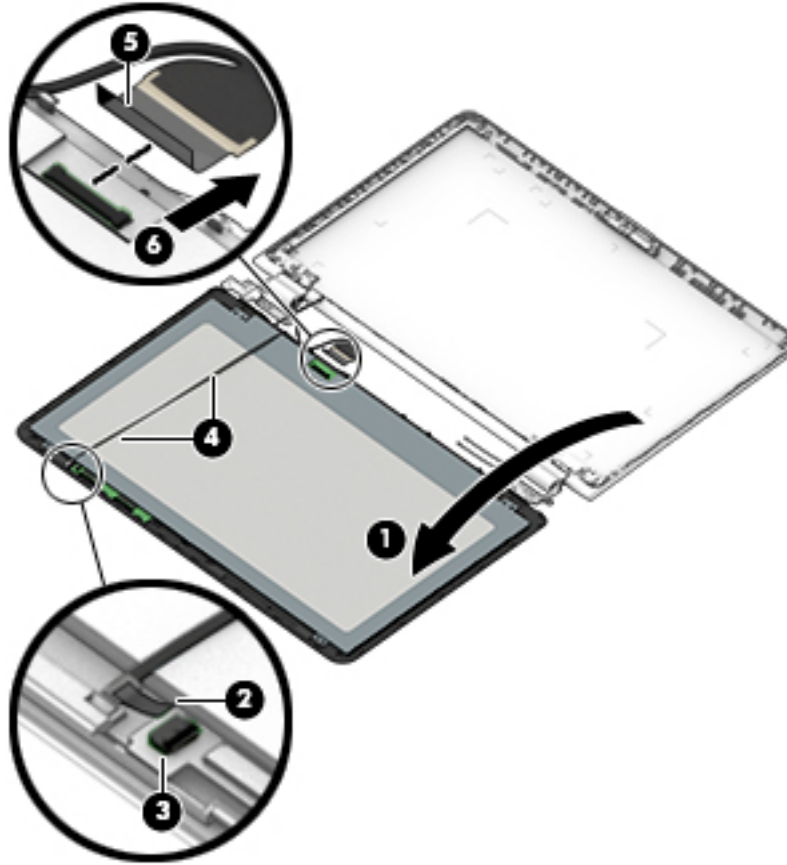

- i.** Remove the display panel assembly.

The display panel assembly is available using spare part numbers 862643-001 (15.6-in, FHD, WLED, AntiGlare (1920×1080), slim-flat (3.2-mm), UWVA, eDP) and 862644-001 (15.6-in, HD, WLED, BrightView (1366×768), slim-flat (3.2-mm), SVA, eDP).

- 6.** If it is necessary to replace the webcam/microphone module:

- a.** Remove the display panel assembly.
- b.** Detach the webcam/microphone module **(1)** from the display back cover. The webcam/microphone module is attached to the display back cover with double-sided adhesive.)

- c. Disconnect the webcam/microphone module cable **(2)** from the webcam/microphone module.

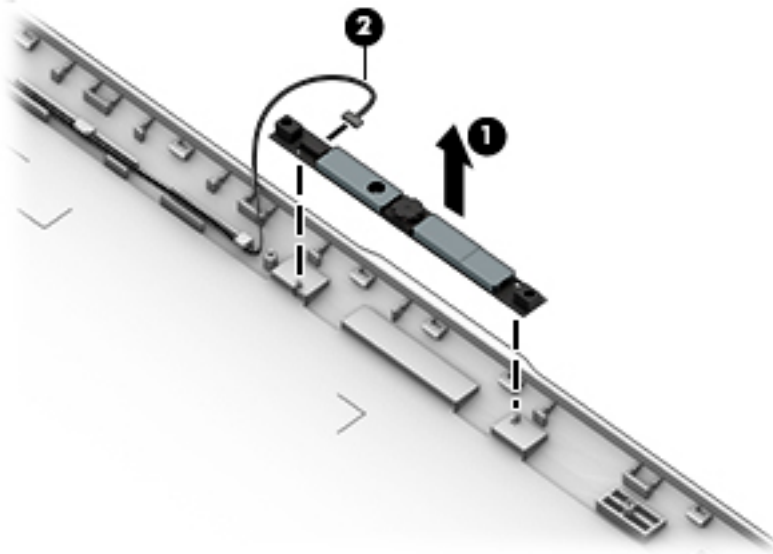

- d. Remove the webcam/microphone module.  
The webcam/microphone module is available using spare part number 756762-035.
7. If it is necessary to replace the display hinges:
- a. Remove the display panel assembly.
  - b. Release the display panel cable **(1)** and the wireless antenna cables **(2)** from the display hinge covers.
  - c. Remove the ten Phillips PM2.5×3.3 screws **(3)** that secure the display hinges to the display back cover.

- d. Rotate the display hinges (4) toward the inside of the display back cover, and then remove the display hinges.

The display hinges are available using spare part number 862642-001.

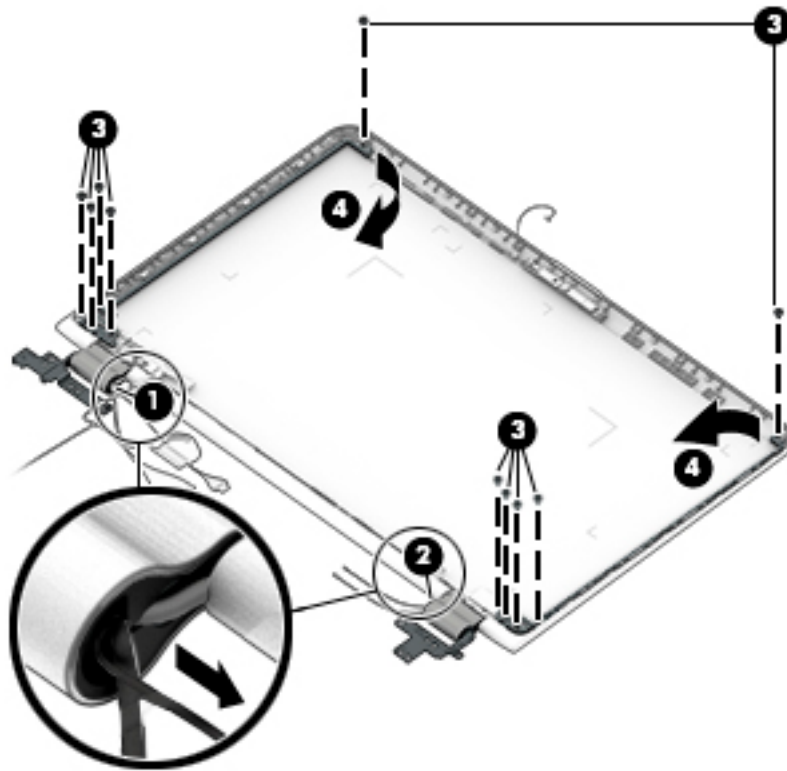

8. If it is necessary to replace the display panel cable:

 **NOTE:** The display panel cable includes the TouchScreen board cable, adhesive support strip, and double-sided adhesive.

- a. Remove the display panel assembly.
- b. Remove the display left hinge.

- c. Remove the display panel cable from the display back cover.

The display panel cable is available using spare part numbers 903913-001 (for use only on computer models with model numbers 15-bk100 through 15-bk199) and 808240-001 (for use only on computer models with model numbers 15-bk000 through 15-bk099).

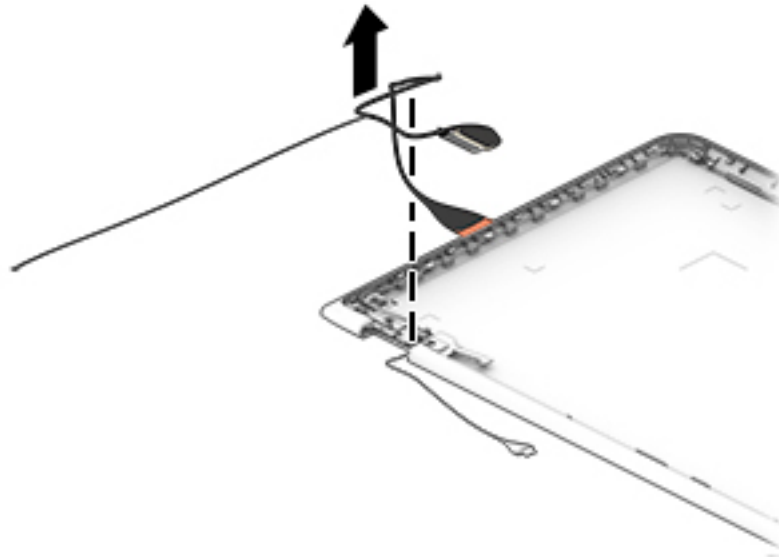

- 9. If it is necessary to replace the G-sensor board:

- a. Remove the display panel assembly.
- b. Release the adhesive support strip **(1)** that secures the G-sensor board cable to the display back cover.
- c. Disconnect the G-sensor board cable **(2)** from the G-sensor board.
- d. Detach the G-sensor board **(3)** from the display back cover. (The G-sensor board is secured to the display back cover with double-sided adhesive.)

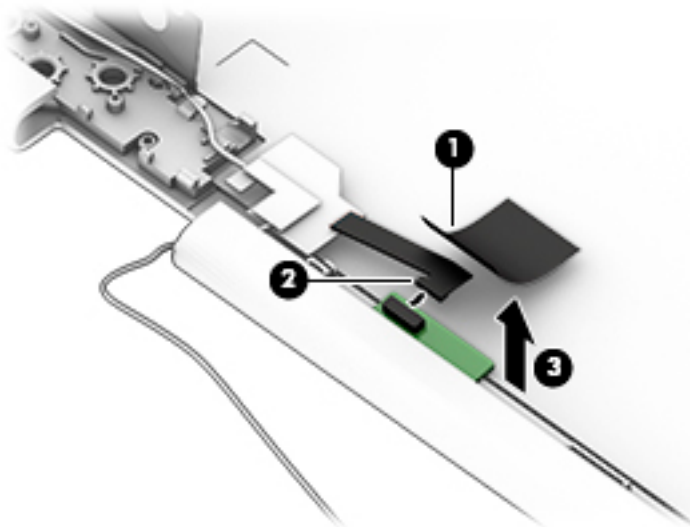

- e. Remove the G-sensor board.

The G-sensor board is available using spare part number 807530-001.

**10.** If it is necessary to replace the webcam/microphone module cable:



**NOTE:** The webcam/microphone module cable includes the G-sensor board cable and double-sided adhesive.

- a. Remove the display panel assembly.
- b. Remove the webcam/microphone module.
- c. Remove the display left hinge.
- d. Release the adhesive support strip **(1)** that secures the G-sensor board cable to the display back cover.
- e. Disconnect the G-sensor board cable **(2)** from the G-sensor board.
- f. Release the shielding **(3)** that secures the webcam/microphone module cable to the display back cover.
- g. Release the webcam/microphone module cable from the retention clips **(4)** and channel built into the left and top edges of the display back cover.
- h. Remove the webcam/microphone module cable **(5)**.

The webcam/microphone module cable is available using spare part numbers 903912-001 (for use only on computer models with model numbers 15-bk100 through 15-bk199) and 807529-001 (for use only on computer models with model numbers 15-bk000 through 15-bk099).

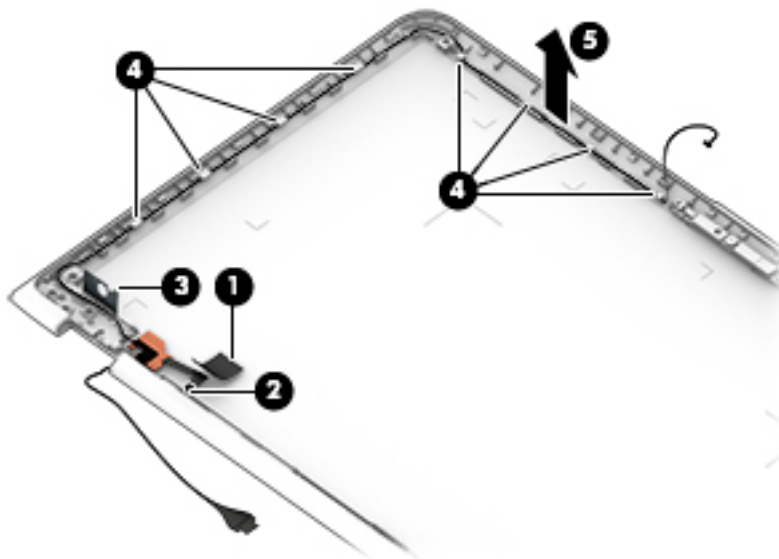

**11.** If it is necessary to replace the wireless antenna:

- a. Remove the display panel assembly.
- b. Remove the display right hinge.
- c. Detach the wireless antenna transceivers **(1)** from the display back cover. (The wireless antenna transceivers are secured to the display back cover with double-sided adhesive.)
- d. Detach the retention tape **(2)** that secures the wireless antenna cables to the display back cover.
- e. Release the wireless antenna cables from the routing clips **(3)** and channel built into the display back cover.

- f. Remove the wireless antenna cables and transceivers (4).

The wireless antenna cables and transceivers are available using spare part number 862635-001.

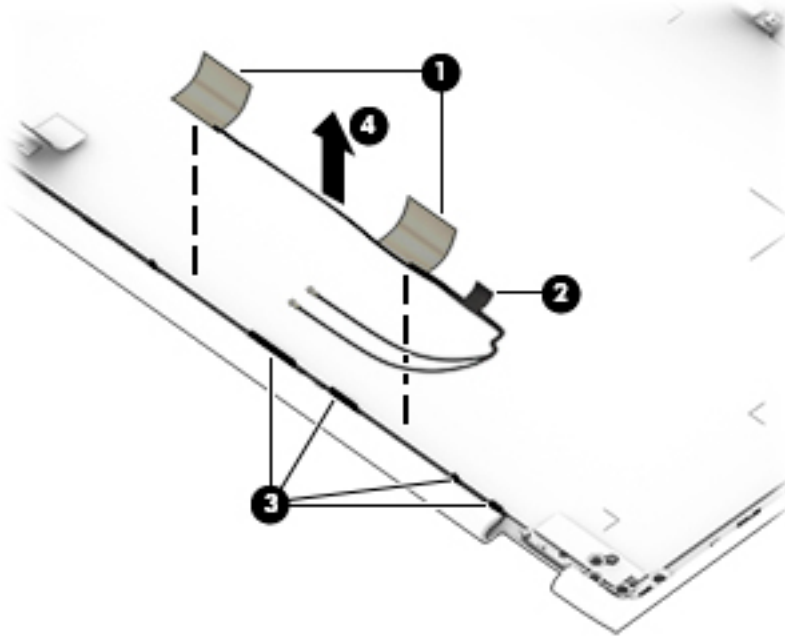

Reverse this procedure to reassemble and install the display assembly.



## Power button board

Description	Spare part number
Power button board (includes cable and double-sided adhesive)	807528-001

Before removing the power connector cable, follow these steps:

1. Turn off the computer. If you are unsure whether the computer is off or in Hibernation, turn the computer on, and then shut it down through the operating system.
2. Disconnect the power from the computer by unplugging the power cord from the computer.
3. Disconnect all external devices from the computer.
4. Remove the base enclosure (see [Keyboard/top cover on page 28](#)).
5. Disconnect the battery cable from the system board (see [Battery on page 33](#)).
6. Disconnect the WLAN module antenna cables from the WLAN module (see [WLAN module on page 37](#)).
7. Remove the system board (see [System board on page 40](#)).
8. Remove the display assembly (see [Display assembly on page 48](#)).

Remove the power button board:

1. Remove the Phillips PM2.5×4.4 screw **(1)** that secures the power button board to the base enclosure.
2. Release the power button board by “toeing” the front edge **(2)** up and forward.
3. Remove the power button board **(3)** by sliding it up and forward at an angle.

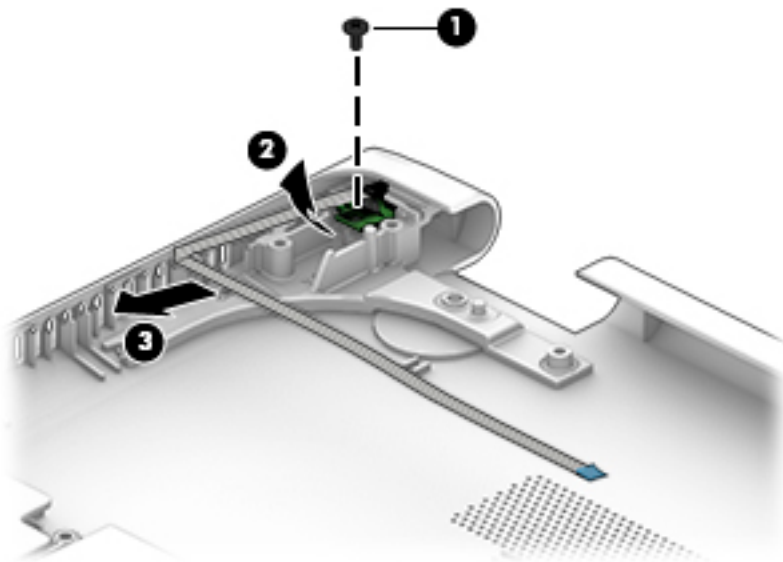

Reverse this procedure to install the power connector cable.

## Power connector cable

Description	Spare part number
Power connector cable	807522-001

Before removing the power connector cable, follow these steps:

1. Turn off the computer. If you are unsure whether the computer is off or in Hibernation, turn the computer on, and then shut it down through the operating system.
2. Disconnect the power from the computer by unplugging the power cord from the computer.
3. Disconnect all external devices from the computer.
4. Remove the base enclosure (see [Keyboard/top cover on page 28](#)).
5. Disconnect the battery cable from the system board (see [Battery on page 33](#)).
6. Disconnect the WLAN module antenna cables from the WLAN module (see [WLAN module on page 37](#)).
7. Remove the system board (see [System board on page 40](#)).
8. Remove the display assembly (see [Display assembly on page 48](#)).

Remove the power connector cable:

1. Remove the Phillips PM2.0×2.3 screw **(1)** that secures the power connector cable and bracket to the base enclosure.
2. Remove the power connector cable bracket **(2)** by lifting it up, and then sliding it to the left.
3. Remove the power connector cable **(3)** by sliding it to the left.

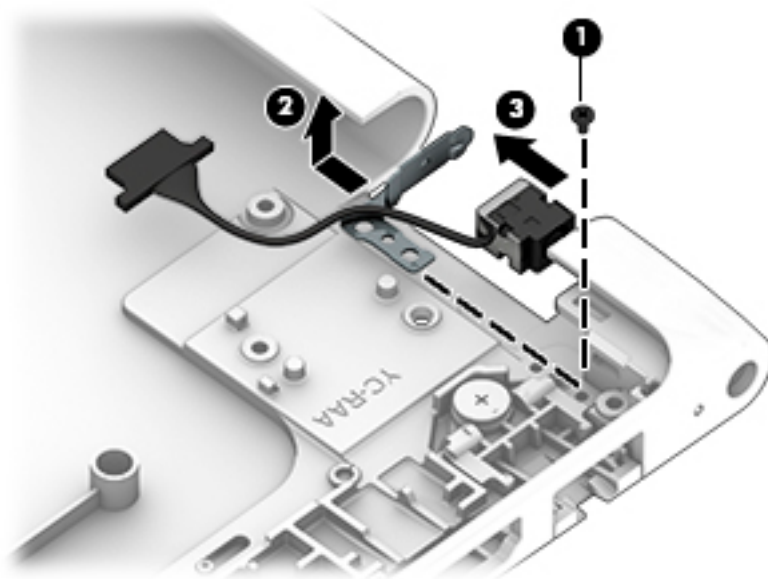

Reverse this procedure to install the power connector cable.

---

## 6 Using Setup Utility (BIOS)

Setup Utility, or Basic Input/Output System (BIOS), controls communication between all the input and output devices on the system (such as disk drives, display, keyboard, mouse, and printer). Setup Utility (BIOS) includes settings for the types of devices installed, the startup sequence of the computer, and the amount of system and extended memory.

---

 **NOTE:** To start Setup Utility on convertible computers, your computer must be in notebook mode and you must use the keyboard attached to your notebook.

---

### Starting Setup Utility (BIOS)

---

 **CAUTION:** Use extreme care when making changes in Setup Utility (BIOS). Errors can prevent the computer from operating properly.

---

- ▲ Turn on or restart the computer, quickly press **esc**, and then press **f10**.

### Updating Setup Utility (BIOS)

Updated versions of Setup Utility (BIOS) may be available on the HP website.

Most BIOS updates on the HP website are packaged in compressed files called *SoftPaqs*.

Some download packages contain a file named *Readme.txt*, which contains information regarding installing and troubleshooting the file.

### Determining the BIOS version

To decide whether you need to update Setup Utility (BIOS), first determine the BIOS version on your computer.

To reveal the BIOS version information (also known as *ROM date* and *System BIOS*), use one of these options.

- HP Support Assistant
  1. Type `support` in the taskbar search box, and then select the **HP Support Assistant** app.  
– or –  
Click the question mark icon in the taskbar.
  2. Select **My PC**, and then select **Specifications**.
- Setup Utility (BIOS)
  1. Start Setup Utility (BIOS) (see [Starting Setup Utility \(BIOS\) on page 59](#)).
  2. Select **Main**, select **System Information**, and then make note of the BIOS version.
  3. Select **Exit**, select **No**, and then follow the on-screen instructions.

To check for later BIOS versions, see [Downloading a BIOS update on page 60](#).

## Downloading a BIOS update

---

 **CAUTION:** To reduce the risk of damage to the computer or an unsuccessful installation, download and install a BIOS update only when the computer is connected to reliable external power using the AC adapter. Do not download or install a BIOS update while the computer is running on battery power, docked in an optional docking device, or connected to an optional power source. During the download and installation, follow these instructions:

- Do not disconnect power from the computer by unplugging the power cord from the AC outlet.
- Do not shut down the computer or initiate Sleep.
- Do not insert, remove, connect, or disconnect any device, cable, or cord.

 **NOTE:** If your computer is connected to a network, consult the network administrator before installing any software updates, especially system BIOS updates.

---

1. Type `support` in the taskbar search box, and then select the **HP Support Assistant** app.  
– or –  
Click the question mark icon in the taskbar.
2. Click **Updates**, and then click **Check for updates and messages**.
3. Follow the on-screen instructions.
4. At the download area, follow these steps:
  - a. Identify the most recent BIOS update and compare it to the BIOS version currently installed on your computer. If the update is more recent than your BIOS version, make a note of the date, name, or other identifier. You may need this information to locate the update later, after it has been downloaded to your hard drive.
  - b. Follow the on-screen instructions to download your selection to the hard drive.  
  
Make a note of the path to the location on your hard drive where the BIOS update is downloaded. You will need to access this path when you are ready to install the update.

BIOS installation procedures vary. Follow any instructions that appear on the screen after the download is complete. If no instructions appear, follow these steps:

1. Type `file` in the taskbar search box, and then select **File Explorer**.
2. Click your hard drive designation. The hard drive designation is typically Local Disk (C:).
3. Using the hard drive path you recorded earlier, open the folder that contains the update.
4. Double-click the file that has an `.exe` extension (for example, `filename.exe`).  
  
The BIOS installation begins.
5. Complete the installation by following the on-screen instructions.

---

 **NOTE:** After a message on the screen reports a successful installation, you can delete the downloaded file from your hard drive.

---

# 7 Using HP PC Hardware Diagnostics (UEFI)

HP PC Hardware Diagnostics is a Unified Extensible Firmware Interface (UEFI) that allows you to run diagnostic tests to determine whether the computer hardware is functioning properly. The tool runs outside the operating system so that it can isolate hardware failures from issues that are caused by the operating system or other software components.

When HP PC Hardware Diagnostics (UEFI) detects a failure that requires hardware replacement, a 24-digit Failure ID code is generated. This ID code can then be provided to support to help determine how to correct the problem.

---

 **NOTE:** To start diagnostics on a convertible computer, your computer must be in notebook mode and you must use the keyboard attached.

---

To start HP PC Hardware Diagnostics (UEFI), follow these steps:

1. Turn on or restart the computer, and quickly press [esc](#).
2. Press [f2](#).

The BIOS searches three places for the diagnostic tools, in the following order:

- a. Connected USB drive

---

 **NOTE:** To download the HP PC Hardware Diagnostics (UEFI) tool to a USB drive, see [Downloading HP PC Hardware Diagnostics \(UEFI\) to a USB device on page 61](#).

---

- b. Hard drive

- c. BIOS

3. When the diagnostic tool opens, select the type of diagnostic test you want to run, and then follow the on-screen instructions.

---

 **NOTE:** If you need to stop a diagnostic test, press [esc](#).

---

## Downloading HP PC Hardware Diagnostics (UEFI) to a USB device

---

 **NOTE:** The HP PC Hardware Diagnostics (UEFI) download instructions are provided in English only, and you must use a Windows computer to download and create the HP UEFI support environment because only .exe files are offered.

---

There are two options to download HP PC Hardware Diagnostics to a USB device.

### Download the latest UEFI version

1. Go to <http://www.hp.com/go/techcenter/pcdiags>. The HP PC Diagnostics home page is displayed.
2. In the HP PC Hardware Diagnostics section, select the **Download** link, and then select **Run**.

### Download any version of UEFI for a specific product

1. Go to <http://www.hp.com/support>.
2. Select **Get software and drivers**.

3. Enter the product name or number.

– or –

Select **Identify now** to let HP automatically detect your product.

4. Select your computer, and then select your operating system.
5. In the **Diagnostic** section, follow the on-screen instructions to select and download the UEFI version you want.

# 8 Specifications

## Computer specifications

The power information in this section may be helpful if you plan to travel internationally with the computer.

The computer operates on DC power, which can be supplied by an AC or a DC power source. The AC power source must be rated at 100–240 V, 50–60 Hz. Although the computer can be powered from a standalone DC power source, it should be powered only with an AC adapter or a DC power source that is supplied and approved by HP for use with this computer.

The computer can operate on DC power within the following specifications. Operating voltage and current varies by platform. The voltage and current for your computer is located on the regulatory label.

	Metric	U.S.
<b>Dimensions</b>		
Width	38.2 cm	15.04 in
Depth	25.0 cm	9.84 in
Height	1.9 cm	0.94 in
Weight	2.3 kg	5.07 lbs
<b>Input power</b>		
Operating voltage and current	5 V dc @ 2 A / 12 V dc @ 3 A / 15 V dc @ 3 A – 45 W USB-C	
	5 V dc @ 3 A / 9 V dc @ 3 A / 10 V dc @ 3.75 A / 12 V dc @ 3.75 A / 15 V dc @ 3 A / 20 V dc @ 2.25 A - 45 W USB-C	
	5 V dc @ 3 A / 9 V dc @ 3 A / 10 V dc @ 5.0 A / 12 V dc @ 5.0 A / 15 V dc @ 4.33 A / 20 V dc @ 3.25 A - 65 W USB-C	
	5 V dc @ 3 A / 9 V dc @ 3 A / 10 V dc @ 5.0 A / 12 V dc @ 5.0 A / 15 V dc @ 5.0 A / 20 V dc @ 4.5 A - 90 W USB-C	
	19.5 V dc @ 2.31 A – 45 W	
	19.5 V dc @ 3.33 A – 65 W	
	19.5 V dc @ 4.62 A – 90 W	
	19.5 V dc @ 6.15 A – 120 W	
	19.5 V dc @ 7.70 A – 150 W	
	19.5 V dc @ 10.3 A – 200 W	
<b>NOTE:</b> This product is designed for IT power systems in Norway with phase-to-phase voltage not exceeding 240 V rms.		
<b>Temperature</b>		
Operating	5°C to 35°C	41°F to 95°F
Non-operating	-20°C to 60°C	-4°F to 140°F
<b>Relative humidity</b> (non-condensing)		
Operating	10% to 90%	

	<b>Metric</b>	<b>U.S.</b>
Non-operating	5% to 95%	
<b>Maximum altitude</b> (unpressurized)		
Operating	<b>-15 m to 3,048 m</b>	-50 ft to 10,000 ft
Non-operating	<b>-15 m to 12,192 m</b>	-50 ft to 40,000 ft
<b>NOTE:</b> Applicable product safety standards specify thermal limits for plastic surfaces. The device operates well within this range of temperatures.		



---

# 9 Backing up, restoring, and recovering

This chapter provides information about the following processes. The information in the chapter is standard procedure for most products.

- Creating recovery media and backups
- Restoring and recovering your system

For additional information, refer to the HP support assistant app.

▲ Type `support` in the taskbar search box, and then select the **HP Support Assistant** app.

– or –

Click the question mark icon in the taskbar.

---

 **IMPORTANT:** If you will be performing recovery procedures on a tablet, the tablet battery must be at least 70% charged before you start the recovery process.

**IMPORTANT:** For a tablet with a detachable keyboard, connect the keyboard to the keyboard dock before beginning any recovery process.

---

## Creating recovery media and backups

The following methods of creating recovery media and backups are available on select products only. Choose the available method according to your computer model.

- Use HP Recovery Manager to create HP Recovery media after you successfully set up the computer. This step creates a backup of the HP Recovery partition on the computer. The backup can be used to reinstall the original operating system in cases where the hard drive is corrupted or has been replaced. For information on creating recovery media, see [Creating HP Recovery media \(select products only\) on page 65](#). For information on the recovery options that are available using the recovery media, see [Using Windows tools on page 66](#).
- Use Windows tools to create system restore points and create backups of personal information.

For more information, see [Recovering using HP Recovery Manager on page 67](#).

---

 **NOTE:** If storage is 32 GB or less, Microsoft System Restore is disabled by default.

---

## Creating HP Recovery media (select products only)

If possible, check for the presence of the Recovery partition and the Windows partition. From the **Start** menu, select **File Explorer**, and then select **This PC**.

- If your computer does not list the Windows partition and the Recovery partition, you can obtain recovery media for your system from support. See the *Worldwide Telephone Numbers* booklet included with the computer. You can also find contact information on the HP website. Go to <http://www.hp.com/support>, select your country or region, and follow the on-screen instructions.

You can use Windows tools to create system restore points and create backups of personal information, see [Using Windows tools on page 66](#).

- If your computer does list the Recovery partition and the Windows partition, you can use HP Recovery Manager to create recovery media after you successfully set up the computer. HP Recovery media can be used to perform system recovery if the hard drive becomes corrupted. System recovery reinstalls the original operating system and software programs that were installed at the factory and then configures the settings for the programs. HP Recovery media can also be used to customize the system or restore the factory image if you replace the hard drive.
  - Only one set of recovery media can be created. Handle these recovery tools carefully, and keep them in a safe place.
  - HP Recovery Manager examines the computer and determines the required storage capacity for the media that will be required.
  - To create recovery discs, your computer must have an optical drive with DVD writer capability, and you must use only high-quality blank DVD-R, DVD+R, DVD-R DL, or DVD+R DL discs. Do not use rewritable discs such as CD±RW, DVD±RW, double-layer DVD±RW, or BD-RE (rewritable Blu-ray) discs; they are not compatible with HP Recovery Manager software. Or, instead, you can use a high-quality blank USB flash drive.
  - If your computer does not include an integrated optical drive with DVD writer capability, but you would like to create DVD recovery media, you can use an external optical drive (purchased separately) to create recovery discs. If you use an external optical drive, it must be connected directly to a USB port on the computer; the drive cannot be connected to a USB port on an external device, such as a USB hub. If you cannot create DVD media yourself, you can obtain recovery discs for your computer from HP. See the *Worldwide Telephone Numbers* booklet included with the computer. You can also find contact information on the HP website. Go to <http://www.hp.com/support>, select your country or region, and follow the on-screen instructions.
  - Be sure that the computer is connected to AC power before you begin creating the recovery media.
  - The creation process can take an hour or more. Do not interrupt the creation process.
  - If necessary, you can exit the program before you have finished creating all of the recovery DVDs. HP Recovery Manager will finish burning the current DVD. The next time you start HP Recovery Manager, you will be prompted to continue.

To create HP Recovery media:



---

**IMPORTANT:** For a tablet with a detachable keyboard, connect the keyboard to the keyboard dock before beginning these steps.

---

1. Type `recovery` in the taskbar search box, and then select **HP Recovery Manager**.
2. Select **Create recovery media**, and then follow the on-screen instructions.

If you ever need to recover the system, see [Recovering using HP Recovery Manager on page 67](#).

## Using Windows tools

You can create recovery media, system restore points, and backups of personal information using Windows tools.



---

**NOTE:** If storage is 32 GB or less, Microsoft System Restore is disabled by default.

---

For more information and steps, see the Get started app.

- ▲ Select the **Start** button, and then select the **Get started** app.

# Restore and recovery

There are several options for recovering your system. Choose the method that best matches your situation and level of expertise:

---

 **IMPORTANT:** Not all methods are available on all products.

---

- Windows offers several options for restoring from backup, refreshing the computer, and resetting the computer to its original state. For more information see the Get started app.
  - ▲ Select the **Start** button, and then select the **Get started** app.
- If you need to correct a problem with a preinstalled application or driver, use the Reinstall drivers and/or applications option (select products only) of HP Recovery Manager to reinstall the individual application or driver.
  - ▲ Type `recovery` in the taskbar search box, select **HP Recovery Manager**, select **Reinstall drivers and/or applications**, and then follow the on-screen instructions.
- If you want to recover the Windows partition to original factory content, you can choose the System Recovery option from the HP Recovery partition (select products only) or use the HP Recovery media. For more information, see [Recovering using HP Recovery Manager on page 67](#). If you have not already created recovery media, see [Creating HP Recovery media \(select products only\) on page 65](#).
- On select products, if you want to recover the computer's original factory partition and content, or if you have replaced the hard drive, you can use the Factory Reset option of HP Recovery media. For more information, see [Recovering using HP Recovery Manager on page 67](#).
- On select products, if you want to remove the recovery partition to reclaim hard drive space, HP Recovery Manager offers the Remove Recovery Partition option.

For more information, see [Removing the HP Recovery partition \(select products only\) on page 70](#).

## Recovering using HP Recovery Manager

HP Recovery Manager software allows you to recover the computer to its original factory state by using the HP Recovery media that you either created or that you obtained from HP, or by using the HP Recovery partition (select products only). If you have not already created recovery media, see [Creating HP Recovery media \(select products only\) on page 65](#).

### What you need to know before you get started

- HP Recovery Manager recovers only software that was installed at the factory. For software not provided with this computer, you must either download the software from the manufacturer's website or reinstall the software from the media provided by the manufacturer.

---

 **IMPORTANT:** Recovery through HP Recovery Manager should be used as a final attempt to correct computer issues.

---

- HP Recovery media must be used if the computer hard drive fails. If you have not already created recovery media, see [Creating HP Recovery media \(select products only\) on page 65](#).
- To use the Factory Reset option (select products only), you must use HP Recovery media. If you have not already created recovery media, see [Creating HP Recovery media \(select products only\) on page 65](#).
- If your computer does not allow the creation of HP Recovery media or if the HP Recovery media does not work, you can obtain recovery media for your system from support. See the *Worldwide Telephone Numbers* booklet included with the computer. You can also find contact information from the HP

website. Go to <http://www.hp.com/support>, select your country or region, and follow the on-screen instructions.

---

 **IMPORTANT:** HP Recovery Manager does not automatically provide backups of your personal data. Before beginning recovery, back up any personal data you want to retain.

---

Using HP Recovery media, you can choose from one of the following recovery options:

---

 **NOTE:** Only the options available for your computer display when you start the recovery process.

---

- System Recovery—Reinstalls the original operating system, and then configures the settings for the programs that were installed at the factory.
- Factory Reset—Restores the computer to its original factory state by deleting all information from the hard drive and re-creating the partitions. Then it reinstalls the operating system and the software that was installed at the factory.

The HP Recovery partition (select products only) allows System Recovery only.

## Using the HP Recovery partition (select products only)

The HP Recovery partition allows you to perform a system recovery without the need for recovery discs or a recovery USB flash drive. This type of recovery can be used only if the hard drive is still working.

To start HP Recovery Manager from the HP Recovery partition:

---

 **IMPORTANT:** For a tablet with a detachable keyboard, connect the keyboard to the keyboard dock before beginning these steps (select products only).

---

1. Type `recovery` in the taskbar search box, select **Recovery Manager**, and then select **HP Recovery Environment**.

- or -

For computers or tablets with keyboards attached, press **f11** while the computer boots, or press and hold **f11** as you press the power button.

For tablets without keyboards:

Turn on or restart the tablet, and then quickly hold down the volume down button; then select **f11**.

- or -

Turn on or restart the tablet, and then quickly hold down the Windows button; then select **f11**.

2. Select **Troubleshoot** from the boot options menu.
3. Select **Recovery Manager**, and then follow the on-screen instructions.

## Using HP Recovery media to recover

You can use HP Recovery media to recover the original system. This method can be used if your system does not have an HP Recovery partition or if the hard drive is not working properly.

1. If possible, back up all personal files.
2. Insert the HP Recovery media, and then restart the computer.

---

 **NOTE:** If the computer does not automatically restart in HP Recovery Manager, change the computer boot order. See [Changing the computer boot order on page 69](#).

---

3. Follow the on-screen instructions.

## Changing the computer boot order

If your computer does not restart in HP Recovery Manager, you can change the computer boot order, which is the order of devices listed in BIOS where the computer looks for startup information. You can change the selection to an optical drive or a USB flash drive.

To change the boot order:



---

**IMPORTANT:** For a tablet with a detachable keyboard, connect the keyboard to the keyboard dock before beginning these steps.

---

1. Insert the HP Recovery media.
2. Access BIOS:

For computers or tablets with keyboards attached:

- ▲ Turn on or restart the computer or tablet, quickly press **esc**, and then press **f9** for boot options.

For tablets without keyboards:

- ▲ Turn on or restart the tablet, and then quickly hold down the volume down button; then select **f9**.

- or -

Turn on or restart the tablet, and then quickly hold down the Windows button; then select **f9**.

3. Select the optical drive or USB flash drive from which you want to boot.
4. Follow the on-screen instructions.

## Removing the HP Recovery partition (select products only)

HP Recovery Manager software allows you to remove the HP Recovery partition to free up hard drive space.



**IMPORTANT:** After you remove the HP Recovery partition, you will not be able to perform System Recovery or create HP recovery media from the HP Recovery partition. So before you remove the Recovery partition, create HP Recovery media; see [Creating HP Recovery media \(select products only\) on page 65](#).



**NOTE:** The Remove Recovery Partition option is only available on products that support this function.

Follow these steps to remove the HP Recovery partition:

1. Type `recovery` in the taskbar search box, and then select **HP Recovery Manager**.
2. Select **Remove Recovery Partition**, and then follow the on-screen instructions.

# 10 Power cord set requirements

The wide-range input feature of the computer permits it to operate from any line voltage from 100 to 120 volts AC, or from 220 to 240 volts AC.

The 3-conductor power cord set included with the computer meets the requirements for use in the country or region where the equipment is purchased.

Power cord sets for use in other countries and regions must meet the requirements of the country or region where the computer is used.

## Requirements for all countries

The following requirements are applicable to all countries and regions:

- The length of the power cord set must be at least **1.0 m** (3.2 ft) and no more than **1.8 m** (6 ft).
- All power cord sets must be approved by an acceptable accredited agency responsible for evaluation in the country or region where the power cord set will be used.
- The power cord sets must have a minimum current capacity of 10 amps and a nominal voltage rating of 125 or 250 V AC, as required by the power system of each country or region.
- The appliance coupler must meet the mechanical configuration of an EN 60 320/IEC 320 Standard Sheet C13 connector for mating with the appliance inlet on the back of the computer.

## Requirements for specific countries and regions

Country/region	Accredited agency	Applicable note number
Australia	EANSW	1
Austria	OVE	1
Belgium	CEBC	1
Canada	CSA	2
Denmark	DEMKO	1
Finland	FIMKO	1
France	UTE	1
Germany	VDE	1
Italy	IMQ	1
Japan	METI	3
The Netherlands	KEMA	1
Norway	NEMKO	1
The People's Republic of China	COC	5
South Korea	EK	4

Country/region	Accredited agency	Applicable note number
Sweden	SEMKO	1
Switzerland	SEV	1
Taiwan	BSMI	4
The United Kingdom	BSI	1
The United States	UL	2

1. The flexible cord must be Type H05VV-F, 3-conductor, 1.0-mm<sup>2</sup> conductor size. Power cord set fittings (appliance coupler and wall plug) must bear the certification mark of the agency responsible for evaluation in the country or region where it will be used.
2. The flexible cord must be Type SPT-3 or equivalent, No. 18 AWG, 3-conductor. The wall plug must be a two-pole grounding type with a NEMA 5-15P (15 A, 125 V) or NEMA 6-15P (15 A, 250 V) configuration.
3. The appliance coupler, flexible cord, and wall plug must bear a “T” mark and registration number in accordance with the Japanese Dentori Law. The flexible cord must be Type VCT or VCTF, 3-conductor, 1.00-mm<sup>2</sup> conductor size. The wall plug must be a two-pole grounding type with a Japanese Industrial Standard C8303 (7 A, 125 V) configuration.
4. The flexible cord must be Type RVV, 3-conductor, 0.75-mm<sup>2</sup> conductor size. Power cord set fittings (appliance coupler and wall plug) must bear the certification mark of the agency responsible for evaluation in the country or region where it will be used.
5. The flexible cord must be Type VCTF, 3-conductor, 0.75-mm<sup>2</sup> conductor size. Power cord set fittings (appliance coupler and wall plug) must bear the certification mark of the agency responsible for evaluation in the country or region where it will be used.



---

# 11 Recycling

When a non-rechargeable or rechargeable battery has reached the end of its useful life, do not dispose of the battery in general household waste. Follow the local laws and regulations in your area for battery disposal.

HP encourages customers to recycle used electronic hardware, HP original print cartridges, and rechargeable batteries. For more information about recycling programs, see the HP Web site at <http://www.hp.com/recycle>.

# Index

- A**
  - AC adapter light 12, 13
  - AC adapter, spare part numbers 22
  - action keys 7
  - antenna 6
    - removal 55
    - spare part number 22, 56
  - audio, product description 3
  - audio-in jack 12
  - audio-out jack 12
- B**
  - back cover, spare part numbers 22
  - backups 65
  - base enclosure, spare part numbers 20
  - battery
    - removal 33
    - spare part number 20, 33
  - battery light 12, 13
  - BIOS
    - determining version 59
    - downloading an update 60
    - starting the Setup Utility 59
    - updating 59
  - boot order
    - changing 69
  - bottom components 13
  - buttons
    - power 10
    - TouchPad 9
    - volume 11
    - Windows 12
- C**
  - caps lock light 8
  - chipset, product description 1
  - components
    - bottom 13
    - display 6
    - keys 7
    - left side 10
    - lights 8
    - right side 12
    - TouchPad 9
- computer**
  - major components 16
  - specifications 63
- connector board
  - removal 39
  - spare part number 19, 39
- D**
  - display assembly, removal 48
  - display components 6, 21
  - display panel
    - product description 2
  - display panel assembly
    - removal 49
    - spare part numbers 21, 51
  - display panel cable
    - removal 53
    - spare part numbers 22, 54
  - drive light 11
- E**
  - esc key 7
  - Ethernet, product description 3
  - eyboard/top cover
    - spare part numbers 28
- F**
  - fan/heat sink assembly
    - removal 44
    - spare part numbers 20, 44
  - feet
    - removal 29
    - spare part numbers 30
  - fn key 7
- G**
  - G-sensor board
    - removal 54
    - spare part number 22, 54
  - graphics, product description 1, 2
- H**
  - hard drive
    - product description 2
    - removal 35
    - spare part numbers 19, 35
  - hard drive bracket
    - removal 35
    - spare part number 35
  - hard drive cable
    - removal 36
    - spare part number 35
  - HDMI port 12
  - HDMI-to-VGA adapter, spare part number 22
  - headphone jack 12
  - hinge
    - removal 52
    - spare part number 22, 53
  - hinge cover, spare part number 22
  - HP PC Hardware Diagnostics (UEFI) using 61
  - HP Recovery Manager
    - correcting boot problems 69
    - starting 68
  - HP Recovery media
    - creating 65
    - recovery 68
  - HP Recovery partition
    - recovery 68
    - removing 70
- I**
  - integrated numeric keypad 7
- J**
  - jacks
    - audio-in 12
    - audio-out 12
    - headphone 12
    - microphone 12
    - network 12
    - RJ-45 12
- K**
  - key components 7
  - keyboard
    - product description 4

- keyboard/top cover
  - removal 28
- keyboard/top cover, spare part numbers 17, 18
- keys
  - action 7
  - esc 7
  - fn 7
  - num lock 7
  - Windows 7
- L**
- left-side components 10
- light components 8
- lights
  - AC adapter 12, 13
  - battery 12, 13
  - caps lock 8
  - drive 11
  - mute 8
  - network status 12
  - RJ-45 status 12
  - webcam 6
- locating information
  - hardware 5
  - software 5
- M**
- memory card 10
- memory card reader 10
- memory module
  - product description 2
  - removal 47
  - spare part numbers 20, 47
- memory module shield
  - removal 47
  - spare part number 20, 47
- microphone
  - location 6
  - product description 3
- microphone jack 12
- minimized image recovery 68
- minimized image, creating 67
- miscellaneous parts 22
- model name 1
- mute light 8
- N**
- network jack 12
- network status lights 12
- num lock key 7
- numeric keypad 7
- O**
- operating system, product description 4
- optical drive
  - product description 3
  - spare part number 22
- original system recovery 67
- P**
- pointing device, product description 4
- ports
  - HDMI 12
  - product description 3, 4
  - USB 2.0 10
  - USB 3.0 12
  - USB 3.0 charging 12
- power button 10
- power button board
  - removal 57
  - spare part number 19, 57
- power connector 13
- power connector cable
  - removal 58
  - spare part number 19, 58
- power cord
  - set requirements 71
  - spare part numbers 22
- power requirements, product description 4
- processor
  - product description 1
- product description
  - audio 3
  - chipset 1
  - display panel 2
  - Ethernet 3
  - external media cards 3
  - graphics 1, 2
  - hard drive 2
  - keyboard 4
  - memory module 2
  - microphone 3
  - operating system 4
  - optical drive 3
  - pointing device 4
  - ports 3, 4
  - power requirements 4
- processors 1
- product name 1
- security 4
- sensors 3
- serviceability 4
- video 3
- wireless 3
- product name 1
- R**
- recover
  - options 67
- recovery
  - discs 66, 68
  - HP Recovery Manager 67
  - media 68
  - starting 68
  - supported discs 66
  - system 67
  - USB flash drive 68
  - using HP Recovery media 66
- recovery media
  - creating 65
  - creating using HP Recovery Manager 66
- recovery partition
  - removing 70
- removal/replacement procedures 28
- right-side components 12
- RJ-45 jack 12
- RJ-45 status lights 12
- RTC battery
  - removal 36
  - spare part number 20, 36
- Rubber Kit, spare part numbers 21, 30
- S**
- screw cover plugs
  - removal 30
  - spare part numbers 30
- screw cover strips
  - removal 29
  - spare part numbers 30
- Screw Kit, spare part number 22
- security cable slot 10
- security, product description 4
- sensors, product description 3
- service tag 14

- serviceability, product description 4
- sleeve, spare part number 22
- slots
  - memory card reader 10
  - security cable 10
- speakers
  - location 13
  - removal 34
  - spare part number 20, 34
- specifications 63
- supported discs, recovery 66
- system board
  - removal 40
  - spare part numbers 19, 40
- system recovery 67
- system restore point
  - creating 66
- system restore point, creating 65

## T

- TouchPad buttons 9
- TouchPad components 9
- TouchPad zone 9

## U

- USB 2.0 port 10
- USB 3.0 charging port 12
- USB 3.0 port 12

## V

- vents 10, 13
- video, product description 3
- volume buttons 11

## W

- webcam 6
- webcam light 6
- webcam/microphone module
  - removal 51
  - spare part number 21, 52
- webcam/microphone module cable
  - removal 55
  - spare part numbers 21, 55
- Windows
  - system restore point 65, 66
- Windows button 12
- Windows key 7
- Windows tools
  - using 66

- wireless antenna 6
  - removal 55
  - spare part number 22, 56
- wireless, product description 3
- WLAN antenna 6
  - removal 55
  - spare part number 22, 56
- WLAN module
  - removal 37
  - spare part numbers 19, 37