



# Color LaserJet Enterprise MFP M681, M682



M681dh



Flow M681f

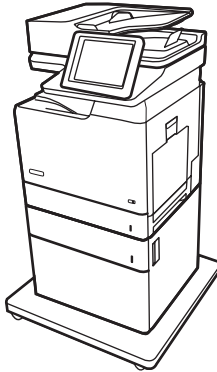

M681f

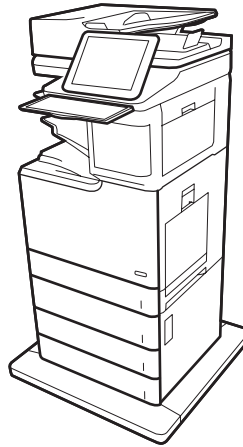

Flow M681z

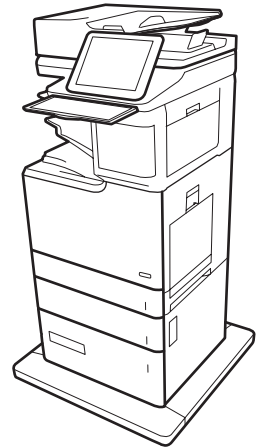

Flow M682z

EN Installation Guide

FR Guide d'installation

ES Guía de instalación

PT Guia de Instalação



[www.hp.com/support/colorljM681MFP](http://www.hp.com/support/colorljM681MFP)  
[www.hp.com/support/colorljM682MFP](http://www.hp.com/support/colorljM682MFP)

ES Lea esto primero

1

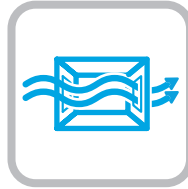
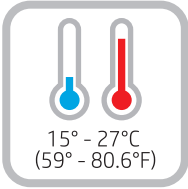

**EN** Select a sturdy, well-ventilated, dust-free area, away from direct sunlight to position the printer.

**FR** Choisissez un support solide et un endroit propre, bien aéré et à l'abri du rayonnement direct du soleil pour placer votre imprimante.

**ES** Busque una superficie sólida en un lugar bien ventilado, sin polvo y alejado de la luz solar directa para colocar la impresora.

**PT** Escolha um local firme, bem ventilado, sem poeira e longe da exposição direta à luz do sol para instalar a impressora.

2

M681dh  
Flow M681f

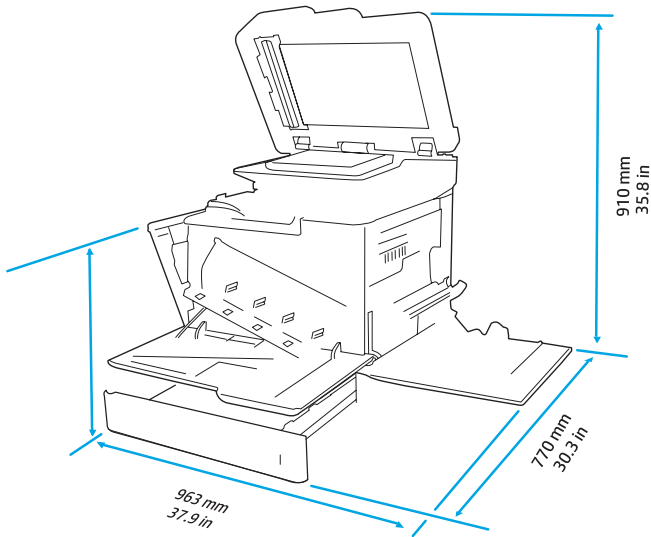
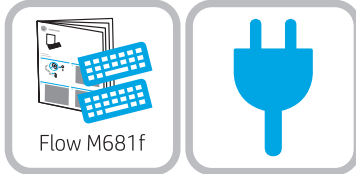
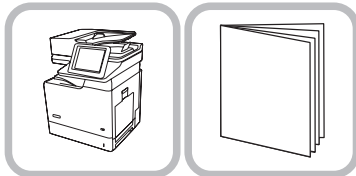
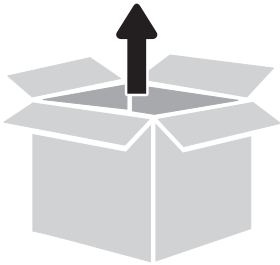

M681f

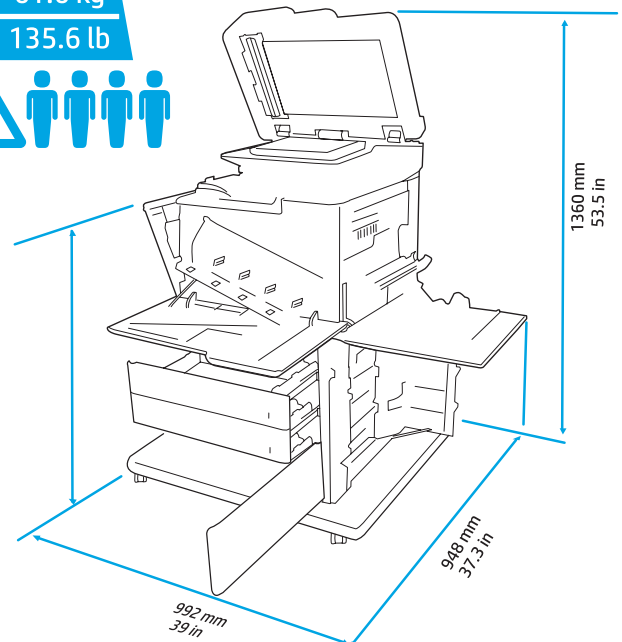
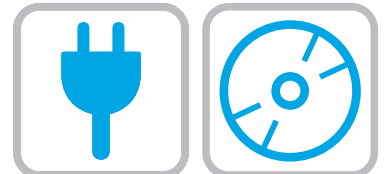
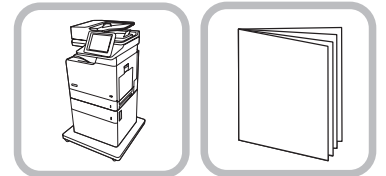
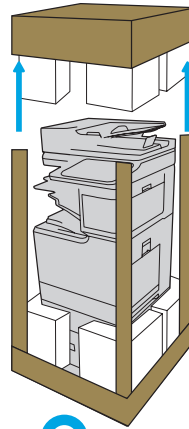

### Flow M681z

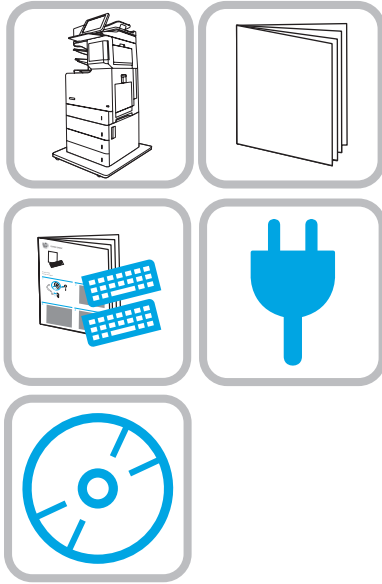
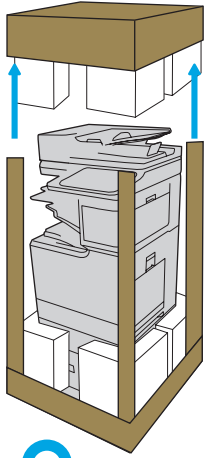

74.7 kg  
164.3 lb

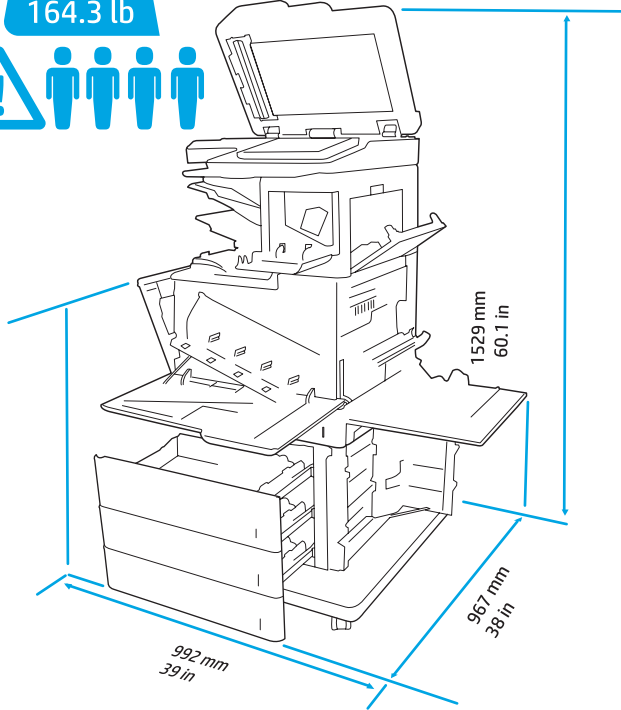

### Flow M682z

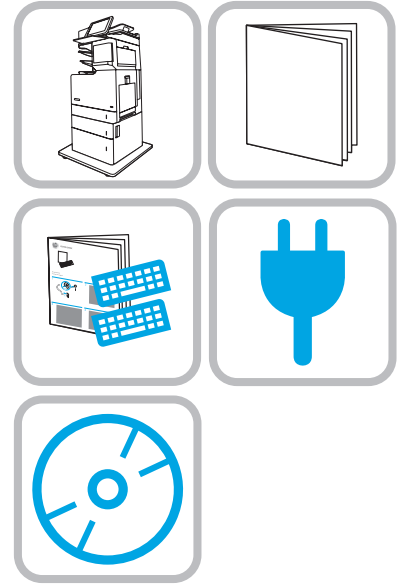
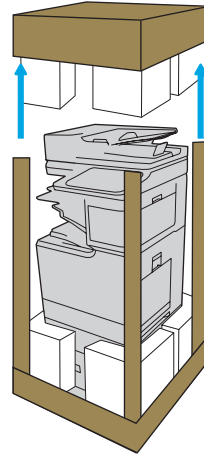

75.4 kg  
165.9 lb

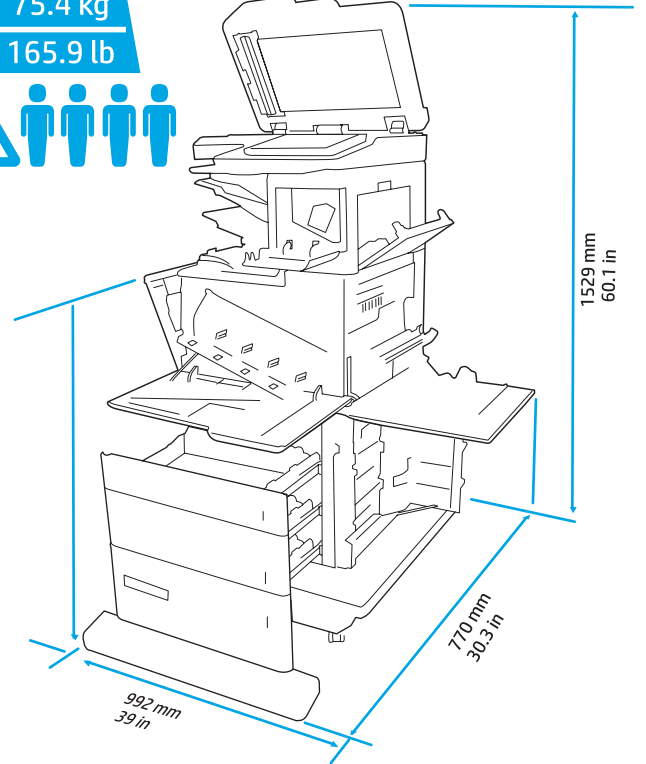

# 3

3.1

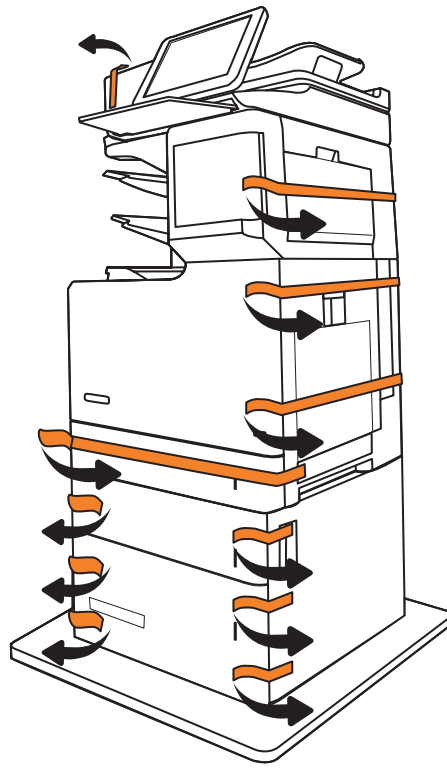

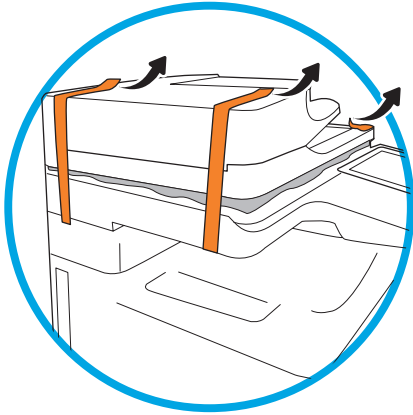

3.2



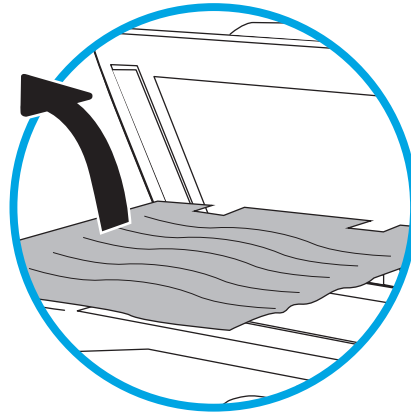

3.3



**EN** **CAUTION:** Do not extend more than one paper tray at a time.  
 Do not use paper tray as a step.  
Keep hands out of paper trays when closing.  
All trays must be closed when moving the printer.

**FR** **ATTENTION :** Ne pas utiliser plus d'un bac à papier à la fois.  
 N'utilisez pas le bac à papier comme marche pied.  
Ecartez vos mains des bacs à papier lors de la fermeture.  
Lorsque vous déplacez l'imprimante, tous les bacs doivent être fermés.

**ES** **PRECAUCIÓN:** No extienda más de una bandeja para papel cada vez.  
 No utilice la bandeja para papel como apoyo para subirse encima.  
Mantenga las manos alejadas de las bandejas para papel cuando las cierre.  
Todas las bandejas deben estar cerradas para mover la impresora.

**PT** **CUIDADO:** Não estenda mais de uma bandeja de papel ao mesmo tempo. Não use papel na bandeja como um degrau. Afaste suas mãos da bandeja do papel ao fechá-la. Todas as bandejas devem estar fechadas quando transportar a impressora.  

4.1

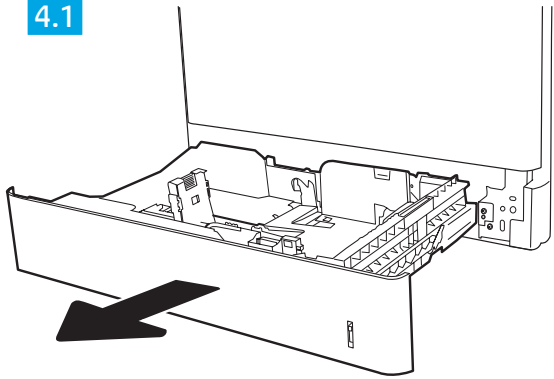

4.2

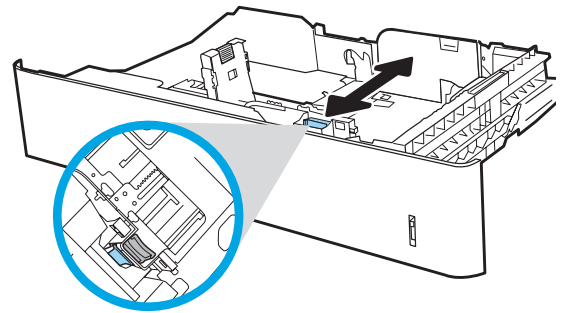

4.3

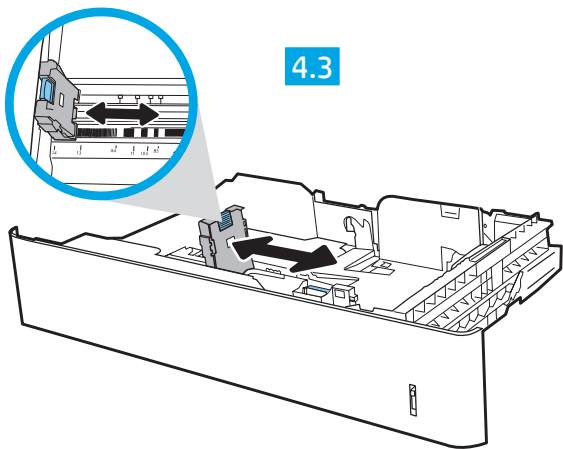

4.4

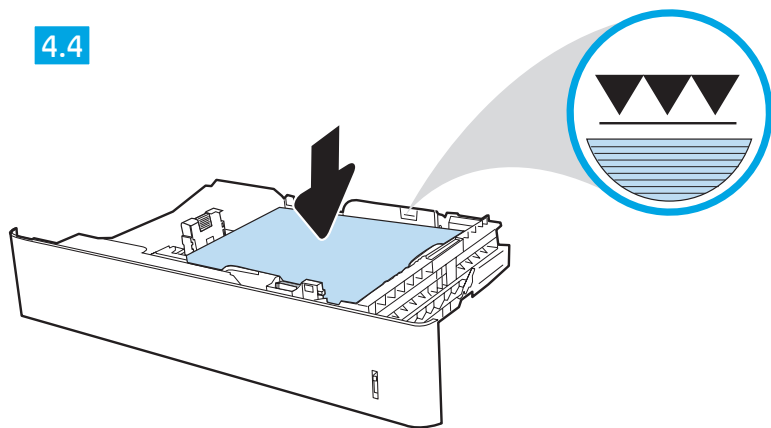

4.5

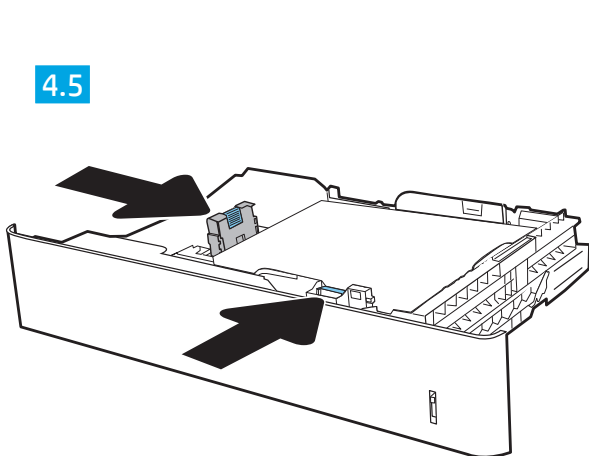

4.6

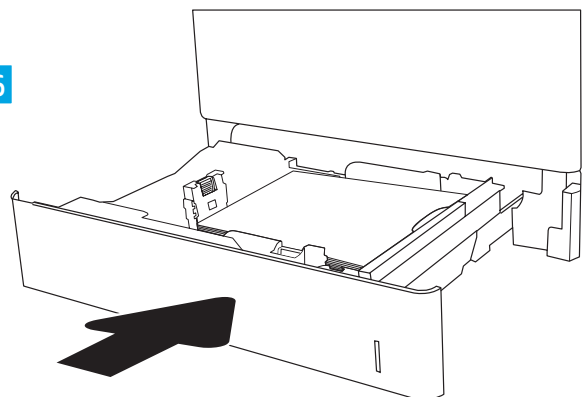

# 5

M681f  
Flow M681z  
Flow M682z

5.1

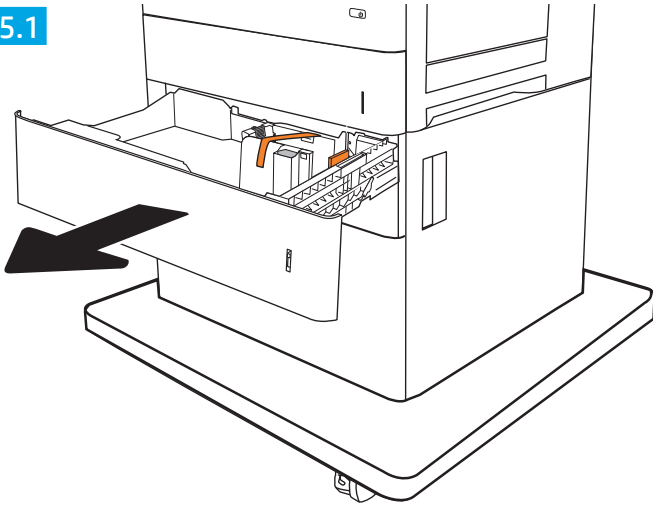

5.2

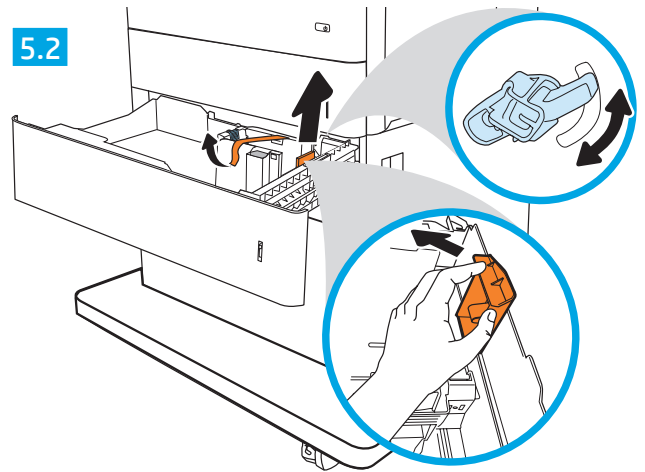

5.3

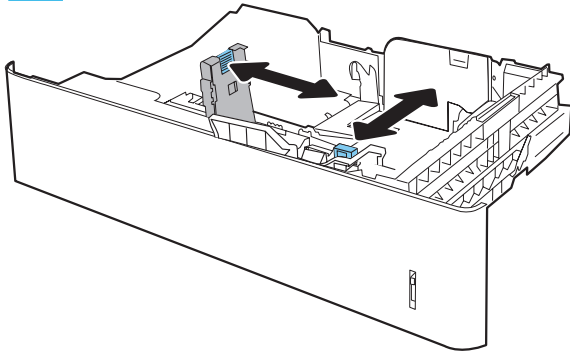

5.4

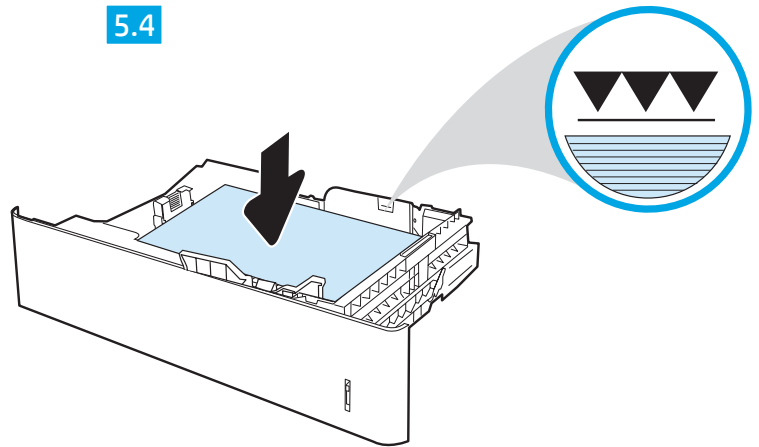

5.5

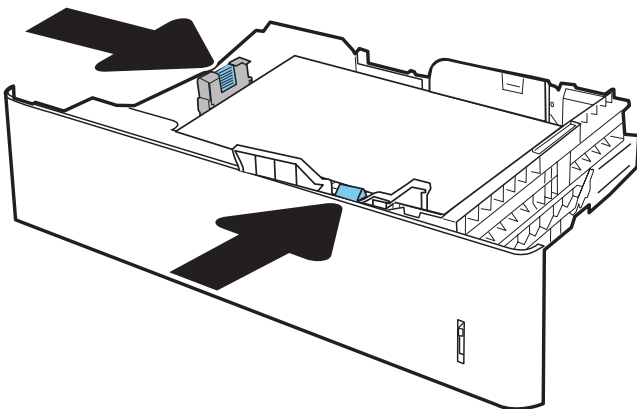

5.6

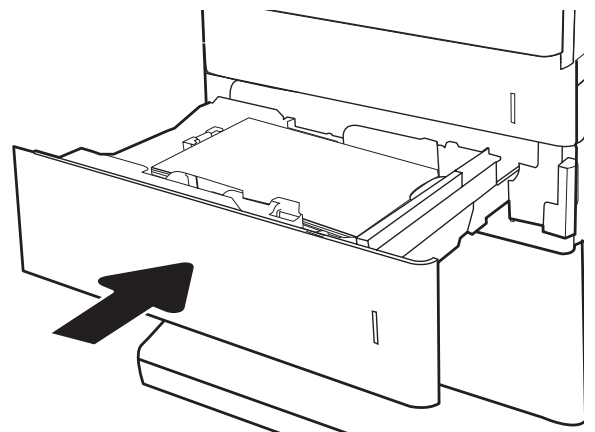

6.1

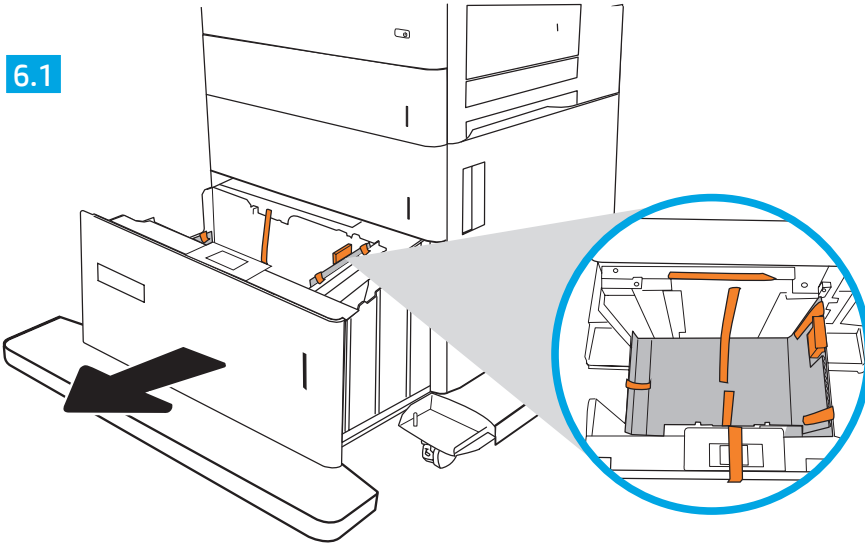

6.2



6.3

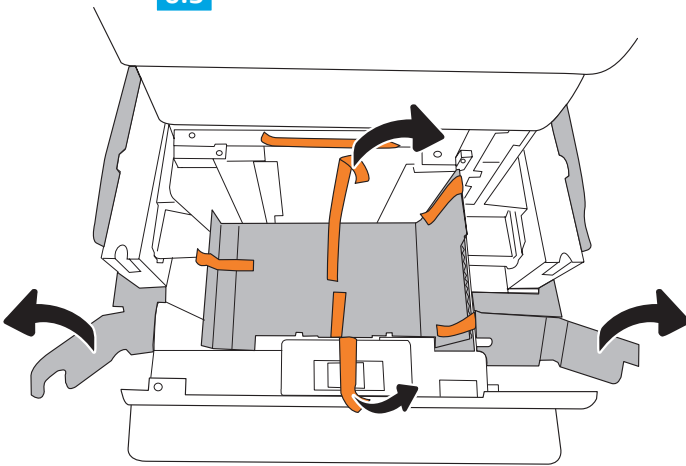

6.4

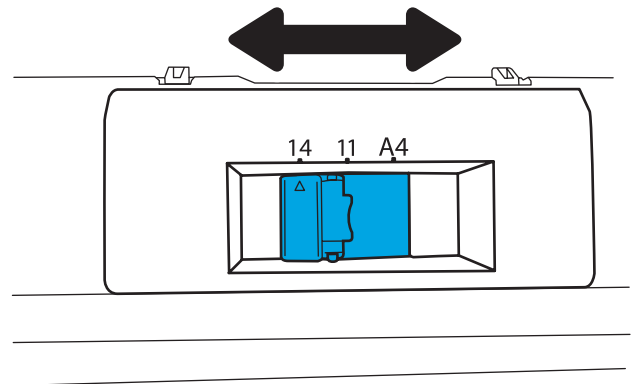

6.5

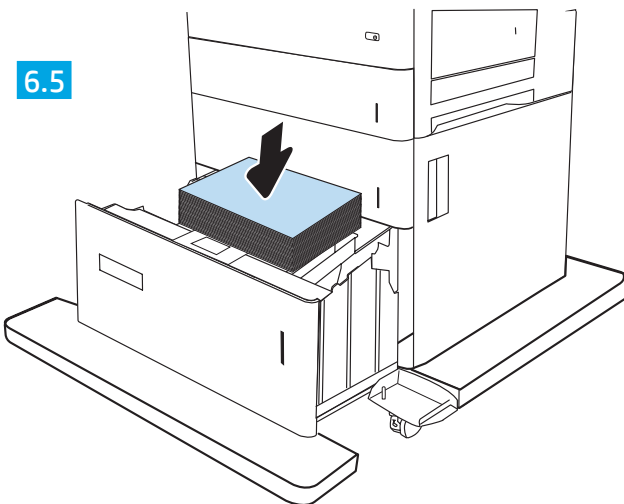

6.6

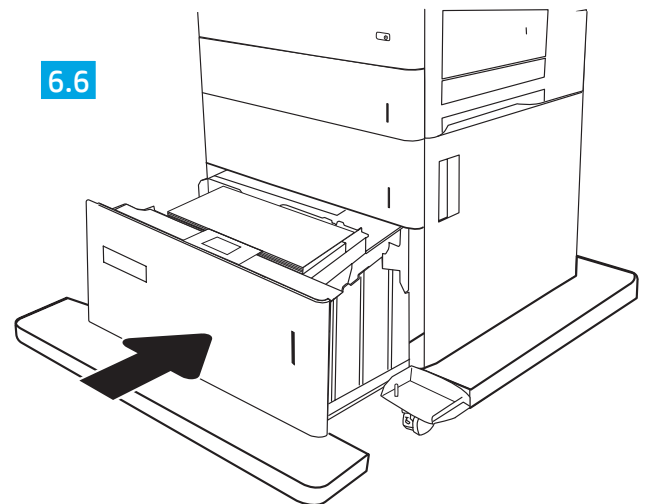



# 7



**EN** If you are connecting to a network, connect the network cable now.  
**CAUTION:** Do not connect the USB cable now.  
**NOTE:** The cables are not included with the printer.

**ES** Si se está conectando a una red, conecte ahora el cable de red.  
**PRECAUCIÓN:** No conecte todavía el cable USB.  
**NOTA:** Los cables no se incluyen con la impresora.

**FR** Si vous vous connectez à un réseau, branchez le câble réseau maintenant.  
**ATTENTION :** Ne connectez pas le câble USB pour le moment.  
**REMARQUE :** Les câbles ne sont pas fournis avec l'imprimante.

**PT** Se estiver conectando em rede, conecte o cabo de rede agora.  
**CUIDADO:** Não conecte o cabo USB agora.  
**NOTA:** Os cabos não estão incluídos com a impressora.

# 8



Flow M681f  
 M681f  
 Flow M681z  
 Flow M682z

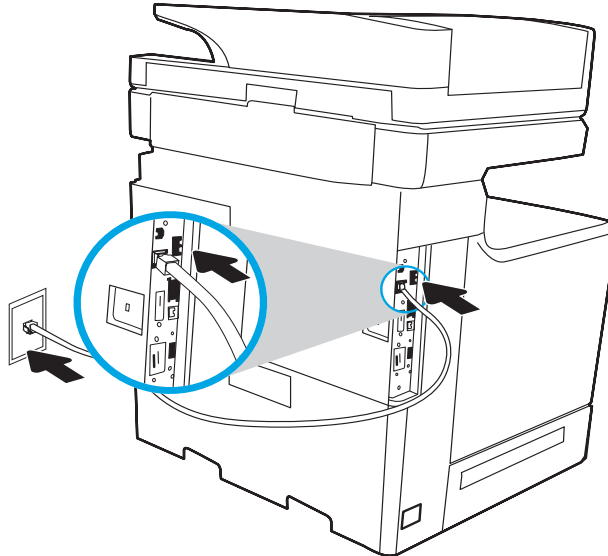

**EN** Connect the phone cord for fax. A country/region specific adapter for the RJ11 telephone cord may be required to connect to the telephone jack.  
**NOTE:** The cables are not included with the printer.

**ES** Conecte el cable telefónico para fax. Puede que se requiera un adaptador específico de país/región para conectar el cable telefónico RJ11 a la toma de teléfono.  
**NOTA:** Los cables no se incluyen con la impresora.

**FR** Branchez le cordon téléphonique au télécopieur. Un adaptateur spécifique à votre pays/région pour le cordon de téléphone RJ11 peut être requis pour le branchement à la prise téléphonique.  
**REMARQUE :** Les câbles ne sont pas fournis avec l'imprimante.

**PT** Conecte o cabo telefónico para fax. Um adaptador específico do país/região pode ser necessário para conectar o cabo telefónico RJ-11 à tomada telefónica.  
**NOTA:** Os cabos não estão incluídos com a impressora.

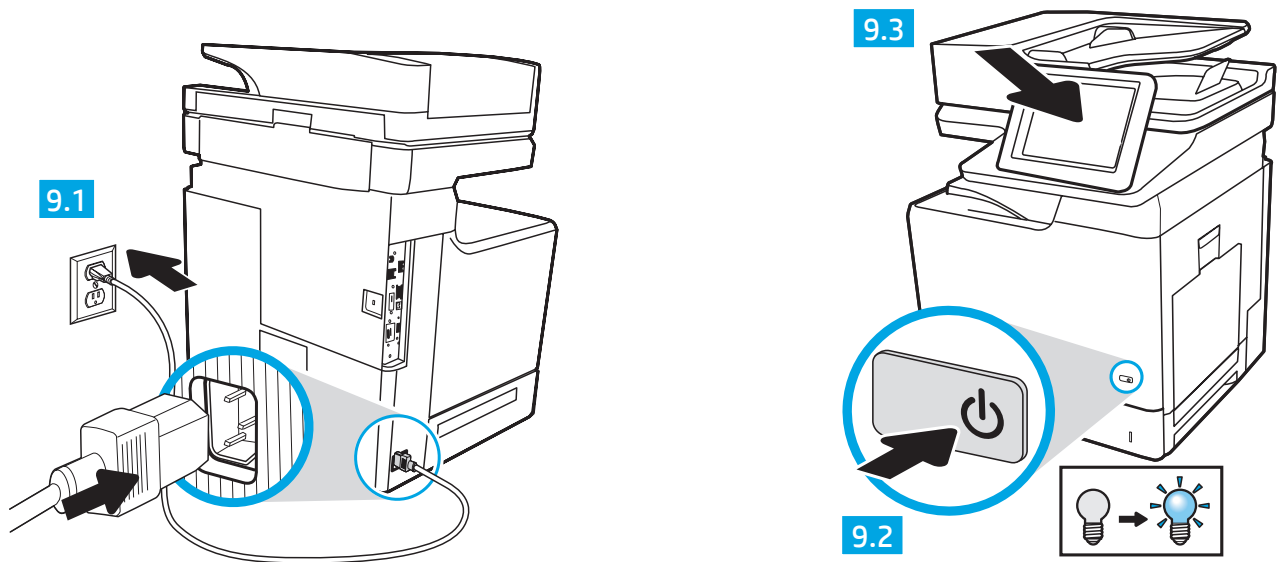

**EN** 9.1 Connect the power cable between the printer and a grounded AC outlet. 9.2 Turn on the printer. 9.3 On the **Initial Setup** screen, set the language, the location, the date/time format, and other features.

**NOTE:** For advanced setup for network-connected printers, enter the printer IP address in the address bar of a web browser after software installation is complete. To find the IP address, select the Information **i** button, and then select the Network **🌐** icon.

**CAUTION:** Make sure your power source is adequate for the printer voltage rating. The voltage rating is on the printer label. The printer uses 100-127 Vac or 220-240 Vac and 50/60 Hz. To prevent damage to the printer, use only the power cable that is provided with the printer.

**FR** 9.1 Connectez le cordon d'alimentation entre l'imprimante et une prise secteur avec mise à la terre. 9.2 Allumez l'imprimante. 9.3 Sur l'écran de **configuration initiale**, définissez la langue, le lieu, le format de date et d'heure, et d'autres fonctions.

**REMARQUE :** Pour effectuer la configuration avancée des imprimantes connectées en réseau, entrez l'adresse IP de l'imprimante dans la barre d'adresse d'un navigateur Web après avoir terminé l'installation de l'imprimante. Pour rechercher l'adresse IP, sélectionnez le bouton d'information **i**, puis l'icône de réseau **🌐**.

**ATTENTION :** Vérifiez que la source d'alimentation électrique est adéquate pour la tension nominale de l'imprimante. Cette tension nominale est indiquée sur l'étiquette de l'imprimante. L'imprimante utilise 100-127 V (ca) ou 220-240 V (ca) et 50/60 Hz. Afin d'éviter d'endommager l'imprimante, utilisez uniquement le cordon d'alimentation fourni avec l'imprimante.

**ES** 9.1 Conecte el cable de alimentación a la impresora y a una toma de CA con conexión a tierra. 9.2 Encienda la impresora. 9.3 En la pantalla **Configuración inicial**, configure el idioma, la ubicación, el formato de fecha/hora y otras características.

**NOTA:** Para realizar una configuración avanzada de las impresoras que se conectan a la red, una vez finalizada la instalación del software, introduzca la dirección IP de la impresora en la barra de direcciones de un navegador web. Para encontrar la dirección IP, seleccione el botón **i** y, a continuación, seleccione el icono **🌐** Red.

**PRECAUCIÓN:** Asegúrese de que la fuente de alimentación es adecuada para el voltaje de la impresora. La información sobre el voltaje se encuentra en la etiqueta de la impresora. La impresora utiliza 100-127 VCA o 220-240 VCA y 50/60 Hz. Para evitar daños a la impresora, utilice solo el cable de alimentación que se proporciona con esta.

**ADVERTENCIA:** Para evitar daños en el producto, en áreas en las que se utilice 110 V y 220 V, verifique el voltaje del enchufe.

**PT** 9.1 Conecte o cabo de alimentação entre a impressora e uma tomada CA aterrada. 9.2 Ligue a impressora. 9.3 Na tela **Configuração inicial**, defina o idioma, o local, o formato de data e hora e outros recursos.

**NOTA:** Para configuração avançada de impressoras conectadas em rede, digite o endereço IP da impressora na barra de endereço de um navegador da Web depois de concluir a instalação do software. Para encontrar o endereço IP, selecione o botão Informações e **i**, depois, o ícone de rede **🌐**.

**CUIDADO:** Verifique se a fonte de alimentação é adequada para a classificação de tensão da impressora. A classificação de tensão está na etiqueta da impressora. A impressora utiliza 100-127 Vca ou 220-240 Vca e 50/60 Hz. Para evitar danos à impressora, utilize somente o cabo de alimentação fornecido com a impressora.

**AVISO:** Para impedir danos ao produto, em áreas onde 110V e 220V estiverem em uso, verifique a tensão da tomada.

# 10

Flow M681z

10.1

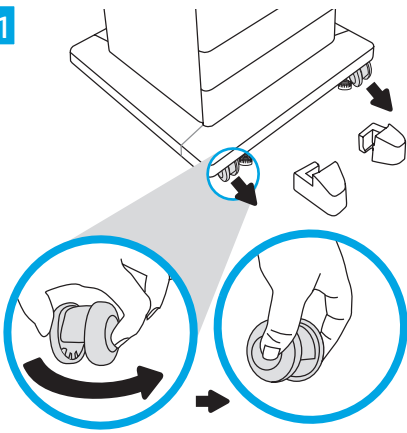

10.2

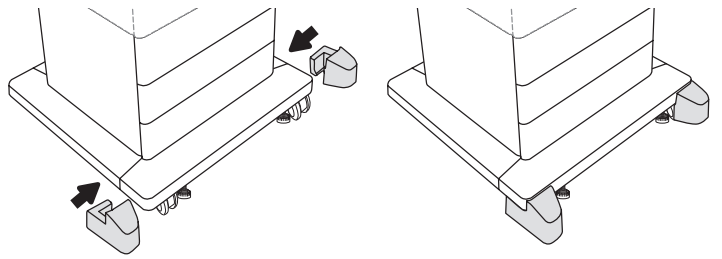

10.3

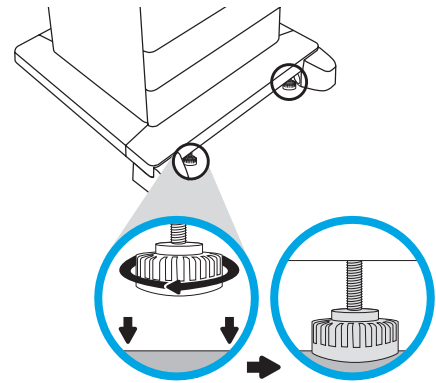

M681f  
Flow M682z

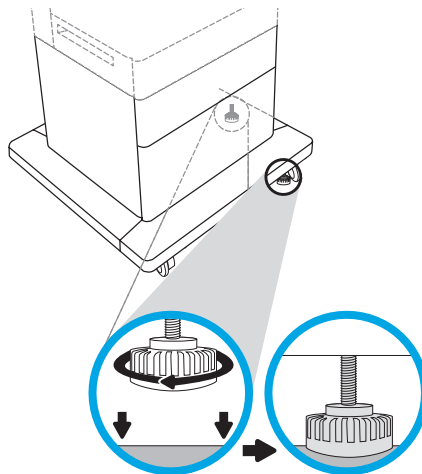

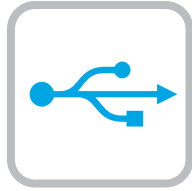

 Windows

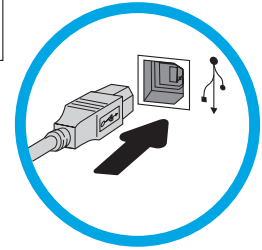
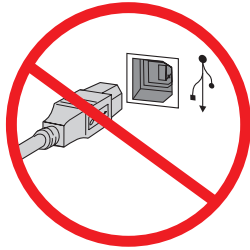

**EN** **Windows:** Do not connect the USB cable until prompted during the software installation in the next step. If the network cable was connected in step 8, proceed to step 12.

**Mac:** Connect the USB cable now.

**NOTE:** The cables are not included with the printer.

**FR** **Windows :** ne branchez pas le câble USB tant que vous n'y êtes pas invité durant l'installation du logiciel à l'étape suivante. Si le câble réseau a été connecté à l'étape 8, passez à l'étape 12.

**Mac :** branchez le câble USB maintenant.

**REMARQUE :** Les câbles ne sont pas fournis avec l'imprimante.

**ES** **Windows:** No conecte el cable USB hasta que se le indique durante la instalación del software en el siguiente paso. Si el cable de red se conectó en el paso 8, continúe con el paso 12.

**Mac:** Conecte ahora el cable USB.

**NOTA:** Los cables no se incluyen con la impresora.

**PT** **Windows:** Não conecte o cabo USB até que seja solicitado a fazê-lo durante a instalação do software na próxima etapa. Se o cabo de rede foi conectado na etapa 8, vá para a etapa 12.

**Mac:** Conecte o cabo USB agora.

**NOTA:** Os cabos não estão incluídos com a impressora.



EN

Locate or download the software installation files

#### Method 1: Download HP Easy Start (Windows and OS X)

1. Go to [123.hp.com/laserjet](http://123.hp.com/laserjet) and click **Download**.
2. Follow the onscreen instructions to download and launch the installation file.
3. Follow the onscreen instructions to run the software installation.

#### Method 2: Download from Product Support website (Windows and OS X)

1. Go to [www.hp.com/support/colorljM681MFP](http://www.hp.com/support/colorljM681MFP) or [www.hp.com/support/colorljM682MFP](http://www.hp.com/support/colorljM682MFP).
2. Select **Software and Drivers**.
3. Download the software for your printer model and operating system.
4. Launch the installation file by clicking on the .exe or .zip file as necessary.

#### Method 3: Install from the printer CD (Windows only)

Insert the printer CD into the computer and follow the on-screen instructions. See the Install Notes file on the product CD for more specific software installation instructions.

#### Method 4: IT managed setup (Windows only)

Visit [hp.com/go/upd](http://hp.com/go/upd) to download and install the HP Universal Print Driver.

**OS X INSTALL NOTE:** If connecting using a USB cable, complete the following steps to configure the output device:

1. From the Apple menu, click **System Preferences**.
2. Select **Print & Scan** (or **Printers & Scanners**).
3. Select the printer, select **Options & Supplies**, and then select **Driver**.
4. Manually configure the accessory.



**NOTE:** See the install notes on the printer CD for features not supported in Windows XP, Windows Vista®, Server 2003, and Server 2008 (all 32 bit versions).

FR

Localiser ou télécharger les fichiers d'installation du logiciel

#### Méthode 1 : Téléchargement de HP Easy Start (Windows et OS X)

1. Rendez-vous sur [123.hp.com/laserjet](http://123.hp.com/laserjet) et cliquez sur **Télécharger**.
2. Suivez les instructions à l'écran pour télécharger et lancer le fichier d'installation.
3. Suivez les instructions à l'écran pour installer le logiciel.

#### Méthode 2 : Téléchargement à partir du site Web d'assistance du produit (Windows et OS X)

1. Rendez-vous sur [www.hp.com/support/colorljM681MFP](http://www.hp.com/support/colorljM681MFP) ou [www.hp.com/support/colorljM682MFP](http://www.hp.com/support/colorljM682MFP).
2. Sélectionnez **Logiciel et pilotes**.
3. Téléchargez le logiciel adapté à votre modèle d'imprimante et à votre système d'exploitation.
4. Lancez le fichier d'installation en cliquant sur le fichier .exe ou .zip le cas échéant.

#### Méthode 3 : Installation avec le CD de l'imprimante (Windows uniquement)

Insérez le CD de l'imprimante dans l'ordinateur et suivez les instructions affichées à l'écran. Consultez les notes d'installation sur le CD du produit pour obtenir des instructions plus détaillées sur l'installation du logiciel.

#### Méthode 4 : Configuration Géré par le service informatique (Windows uniquement)

Visitez la page [hp.com/go/upd](http://hp.com/go/upd) pour télécharger et installer le pilote d'impression universel HP Pilote d'impression.

**OS X INSTALL NOTE :** Si vous vous connectez par l'intermédiaire d'un câble USB, effectuez les étapes suivantes pour configurer le périphérique de sortie :

1. Dans le menu Apple, cliquez sur **Préférences Système**.
2. Sélectionnez **Imprimer et numériser** (ou **Imprimantes et scanners**).
3. Sélectionnez l'imprimante, puis **Options et consommables**, et sélectionnez **Pilote**.
4. Configurez manuellement l'accessoire.



**REMARQUE :** Voir les notes d'installation sur le CD de l'imprimante pour connaître les fonctions non prises en charge dans la version 32 bits de Windows XP, Windows Vista®, Server 2003 et Server 2008.

## ES Ubicación o descarga de los archivos de instalación del software

### Método 1: Descarga desde HP Easy Start (Windows y OS X)

1. Vaya a [123.hp.com/laserjet](http://123.hp.com/laserjet) y haga clic en **Descargar**.
2. Siga las instrucciones en pantalla para descargar e iniciar el archivo de instalación.
3. Siga las instrucciones en pantalla para instalar el software.

### Método 2: Descarga desde el sitio web de asistencia del producto (Windows y OS X)

1. Vaya a [www.hp.com/support/colorljM681MFP](http://www.hp.com/support/colorljM681MFP) or [www.hp.com/support/colorljM682MFP](http://www.hp.com/support/colorljM682MFP).
2. Seleccione **Software y controladores**.
3. Descargue el software para su modelo de impresora y sistema operativo.
4. Haga clic en el archivo .exe o .zip según sea necesario para iniciar el archivo de instalación.

### Método 3: Instalación desde el CD de la impresora (solo Windows)

Inserte el CD de la impresora en el equipo y siga las instrucciones que se muestran en pantalla. Consulte el archivo Notas de instalación incluido en el CD del producto para obtener instrucciones más específicas acerca de la instalación del software.

### Método 4: Configuración gestionada de IT (solo Windows)

Visite [hp.com/go/upd](http://hp.com/go/upd) para descargar e instalar el HP Universal Controlador de impresión.

**OS X INSTALL NOTA:** Si se conecta utilizando un cable USB, siga los siguientes pasos para configurar el dispositivo de salida:

1. En el menú Apple, haga clic en **Preferencias del sistema**.
2. Seleccione **Print & Scan** (o **Impresoras y escáneres**).
3. Seleccione la impresora, seleccione **Opciones y recambios**, y enseguida seleccione **Controlador**.
4. Configure el accesorio manualmente.

 **NOTA:** Consulte las notas de instalación del CD de la impresora para las funciones que no admite Windows XP, Windows Vista®, Server 2003 y Server 2008 (todas las versiones de 32 bits).

## PT Localizar ou baixar os arquivos de instalação do software

### Método 1: Faça download do HP Easy Start (Windows e OS X)

1. Acesse [123.hp.com/laserjet](http://123.hp.com/laserjet) e clique em **Fazer download**.
2. Siga as instruções na tela para fazer download do arquivo de instalação e para iniciá-lo.
3. Siga as instruções exibidas na tela para executar a instalação do software.

### Método 2: Faça o download no site de suporte do produto (Windows e OS X)

1. Acesse [www.hp.com/support/colorljM681MFP](http://www.hp.com/support/colorljM681MFP) ou [www.hp.com/support/colorljM682MFP](http://www.hp.com/support/colorljM682MFP).
2. Seleccione **Software e Drivers**.
3. Faça download do software para seu modelo de impressora e sistema operacional.
4. Inicie o arquivo de instalação clicando no arquivo .exe ou .zip, conforme necessário.

### Método 3: Instale do CD da impressora (somente Windows)

Insira o CD da impressora no computador e siga as instruções na tela. Para instruções de instalação de software mais específicas, consulte o arquivo Notas de Instalação do CD do produto.

### Método 4: Configuração gerenciada por TI (somente Windows)

Acesse [hp.com/go/upd](http://hp.com/go/upd) para fazer download do HP Universal Print Driver e instalá-lo.

**NOTA DE INSTALAÇÃO DO OS X:** Se você usar um cabo USB para conexão, conclua estas etapas para configurar o dispositivo de saída:

1. No menu Apple, clique em **Preferências do sistema**.
2. Seleccione **Imprimir e digitalizar** (ou **Impressoras e scanners**).
3. Seleccione a impressora. Em seguida, seleccione **Opções e suprimentos** e depois **Driver**.
4. Configure manualmente o acessório.

 **NOTA:** Consulte as notas de instalação no CD da impressora para saber quais recursos não são suportados no Windows XP, Windows Vista®, Server 2003 e Server 2008 (todas as versões de 32 bits).

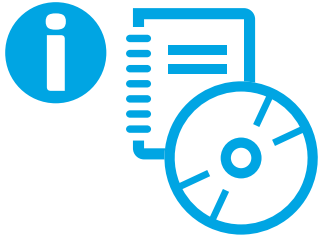

**EN** For information on firmware updates, advanced configuration using the Embedded Web Server, fax and network scan instructions, Scan to Email and remote and mobile printing using HP ePrint, see the User Guide on the printer CD or go to [www.hp.com/support/colorljM681MFP](http://www.hp.com/support/colorljM681MFP) or [www.hp.com/support/colorljM682MFP](http://www.hp.com/support/colorljM682MFP). Press the Help  button on the printer control panel to access Help topics.

**FR** Pour obtenir plus d'informations sur les mises à jour de micrologiciels, la configuration avancée à l'aide du serveur Web intégré, des instructions concernant la télécopie, la numérisation en réseau, la numérisation vers un courrier électronique et l'impression à distance et mobile par l'intermédiaire de HP ePrint, consultez le Manuel de l'utilisateur sur le CD de l'imprimante ou rendez-vous sur [www.hp.com/support/colorljM681MFP](http://www.hp.com/support/colorljM681MFP) ou [www.hp.com/support/colorljM682MFP](http://www.hp.com/support/colorljM682MFP). Appuyez sur le bouton Aide  sur le panneau de commande de l'imprimante pour accéder aux rubriques d'aide.

**ES** Para obtener información acerca de las actualizaciones del firmware, la configuración avanzada mediante el servidor Web incorporado, las instrucciones del envío de faxes y el escaneado en red, escaneado a correo electrónico e impresión remota y móvil utilizando HP ePrint, consulte la Guía del usuario en el CD de la impresora o vaya a [www.hp.com/support/colorljM681MFP](http://www.hp.com/support/colorljM681MFP) o [www.hp.com/support/colorljM682MFP](http://www.hp.com/support/colorljM682MFP). Toque el botón Ayuda  en el panel de control de la impresora para acceder a los temas de ayuda.

**PT** Para obter informações sobre atualizações de firmware, configuração avançada usando o Servidor da Web Incorporado, instruções sobre digitalização em rede, digitalização para e-mail e impressão remota e móvel usando o HP ePrint, consulte o Guia do usuário no CD da impressora ou acesse [www.hp.com/support/colorljM681MFP](http://www.hp.com/support/colorljM681MFP) ou [www.hp.com/support/colorljM682MFP](http://www.hp.com/support/colorljM682MFP). Pressione o botão Ajuda  no painel de controle da impressora para acessar os tópicos da Ajuda.

## Copyright and License

© Copyright 2017 HP Development Company, L.P.

Reproduction, adaptation or translation without prior written permission is prohibited, except as allowed under the copyright laws.

The information contained herein is subject to change without notice.

The only warranties for HP products and services are set forth in the express warranty statements accompanying such products and services. Nothing herein should be construed as constituting an additional warranty. HP shall not be liable for technical or editorial errors or omissions contained herein.

## FCC Regulations

This equipment has been tested and found to comply with the limits for a Class A digital device, pursuant to Part 15 of the FCC rules. These limits are designed to provide reasonable protection against harmful interference in a residential installation. This equipment generates, uses, and can radiate radio frequency energy, and if not installed and used in accordance with the instruction manual, may cause harmful interference to radio communications. Operation of this equipment in a residential area is likely to cause harmful interference in which case the user will be required to correct the interference at his own expense.

**NOTE:** Any changes or modifications to the printer that are not expressly approved by HP could void the user's authority to operate this equipment. Use of a shielded interface cable is required to comply with the Class A limits of Part 15 of FCC rules.

## Trademark Credits

Windows®, Windows® XP, Windows Vista®, Windows® 7, Windows® 8, and Windows Server® are trademarks of the Microsoft Group of companies.

Apple and the Apple logo are trademarks of Apple Inc., registered in the U.S. and other countries.

OS X is a trademark of Apple Inc., registered in the U.S. and other countries.

AirPrint and the AirPrint logo are trademarks of Apple Inc.



J8A10-90940

## Copyright et licence

© Copyright 2017 HP Development Company, L.P.

La reproduction, l'adaptation ou la traduction de ce document sans l'autorisation écrite préalable de HP est interdite, sauf dans des conditions conformes aux lois relatives au copyright.

Les informations contenues dans ce document peuvent être modifiées sans préavis.

Les seules garanties pour les produits et services HP sont décrites dans les déclarations de garantie expresse qui accompagnent ces produits et services. Les informations contenues dans ce document ne constituent en aucun cas une garantie supplémentaire. HP n'est pas responsable des erreurs d'ordre technique ou éditorial ou des omissions contenues dans ce document.

## Réglementations de la FCC

Ce matériel a été testé et respecte les limitations concernant les équipements numériques de classe A, conformément à l'article 15 de la réglementation FCC. Ces limites sont destinées à assurer une protection suffisante contre les interférences produites dans une installation résidentielle. Cet équipement génère, utilise et peut émettre des fréquences radioélectriques. S'il n'est pas installé et utilisé conformément au manuel d'instructions, il peut provoquer des interférences préjudiciables aux communications radio. L'utilisation de cet équipement dans une zone résidentielle peut provoquer des interférences préjudiciables. Dans un tel cas, il incombe à l'utilisateur de corriger ces interférences à ses propres frais.

**REMARQUE :** Toute modification apportée au produit sans le consentement de HP peut se traduire par la révocation du droit d'exploitation de l'équipement dont jouit l'utilisateur. Un câble d'interface blindé est requis afin de satisfaire aux stipulations de l'article 15 des réglementations de la FCC sur les appareils de classe A.

## Créditions concernant les marques

Windows®, Windows® XP, Windows Vista®, Windows® 7, Windows® 8, et Windows Server® sont des marques commerciales du groupe de sociétés Microsoft.

Apple et le logo Apple sont des marques commerciales d'Apple, Inc. enregistrés aux États-Unis et dans d'autres pays/régions.

OS X est une marque commerciale d'Apple Inc. aux États-Unis et dans d'autres pays/régions.

Le nom et le logo AirPrint sont des marques de commerce d'Apple Inc.

