



User Guide

© Copyright 2017 HP Development Company, L.P.

HDMI, the HDMI Logo and High-Definition Multimedia Interface are trademarks or registered trademarks of HDMI Licensing LLC. NVIDIA and G-SYNC are trademarks and/or registered trademarks of NVIDIA Corporation in the U.S. and other countries. Windows is either a registered trademark or trademark of Microsoft Corporation in the United States and/or other countries.

The information contained herein is subject to change without notice. The only warranties for HP products and services are set forth in the express warranty statements accompanying such products and services. Nothing herein should be construed as constituting an additional warranty. HP shall not be liable for technical or editorial errors or omissions contained herein.

Product Notice





This guide describes features that are common to most models. Some features may not be available on your product. To access the latest user guide, go to <http://www.hp.com/support>. Select **Find your product**, and then follow the on-screen instructions.

Second Edition: March 2017

Document Part Number: 912362-002

About This Guide

This guide provides information on monitor features, setting up the monitor, using the software and technical specifications.

-
-  **WARNING!** Indicates a hazardous situation that, if not avoided, **could** result in death or serious injury.
 -  **CAUTION:** Indicates a hazardous situation that, if not avoided, **could** result in minor or moderate injury.
 -  **IMPORTANT:** Indicates information considered important but not hazard-related (for example, messages related to property damage). A notice alerts the user that failure to follow a procedure exactly as described could result in loss of data or in damage to hardware or software. Also contains essential information to explain a concept or to complete a task.
 -  **NOTE:** Contains additional information to emphasize or supplement important points of the main text.
 -  **TIP:** Provides helpful hints for completing a task.
-



This product incorporates HDMI technology.

Table of contents

1 Getting started	1
Important safety information	1
Product features and components	2
Features	2
Identifying rear and side components	3
Setting up the monitor	4
Removing the stand's hinge blocker	4
Connecting the cables	5
Connecting USB devices	8
Adjusting the monitor for comfort	9
Turning on the monitor	10
Installing a security cable	11
Storing headphones	11
Using the ambient light	12
Mounting the display head	13
Removing the monitor stand	13
Attaching the VESA mounting bracket	14
2 Using the monitor	15
Software and utilities	15
Enabling G-SYNC	15
The Setup Information file	15
The Image Color Matching file	15
Installing the .inf and .icm files	16
Installing from the optical disc (available in select regions)	16
Downloading from the web	16
Using the on-screen display (OSD) menu	16
Selecting a faster response time for gaming	17
Using Deep Sleep mode	17
Selecting the Low Blue Light mode	18
3 Support and troubleshooting	19
Solving common problems	19
Menu button lockout	19
Contacting support	20
Preparing to call technical support	20

Locating the serial number and product number	20
4 Maintaining the monitor	21
Maintenance guidelines	21
Cleaning the monitor	21
Shipping the monitor	21
Appendix A Technical specifications	22
Preset display resolutions	23
Entering user modes	23
Power adapter	24
Energy saver feature	24
Appendix B Accessibility	25
Supported assistive technologies	25
Contacting support	25

1 Getting started

Important safety information

An AC power adapter and cord may be included with the monitor. If another cord is used, use only a power source and connection appropriate for this monitor. For information on the correct power cord set to use with the monitor, refer to the *Product Notices* provided on the optical disc or in your documentation kit.

 **WARNING!** To reduce the risk of electric shock or damage to the equipment:

- Plug the power cord into an AC outlet that is easily accessible at all times.
- Disconnect power from the computer by unplugging the power cord from the AC outlet.
- If provided with a 3-pin attachment plug on the power cord, plug the cord into a grounded (earthed) 3-pin outlet. Do not disable the power cord grounding pin, for example, by attaching a 2-pin adapter. The grounding pin is an important safety feature.

For your safety, do not place anything on power cords or cables. Arrange them so that no one may accidentally step on or trip over them.

To reduce the risk of serious injury, read the *Safety & Comfort Guide*. It describes proper workstation setup, and proper posture, health, and work habits for computer users. The *Safety & Comfort Guide* also provides important electrical and mechanical safety information. The *Safety & Comfort Guide* is available on the Web at <http://www.hp.com/ergo>.

 **IMPORTANT:** For the protection of the monitor, as well as the computer, connect all power cords for the computer and its peripheral devices (such as a monitor, printer, scanner) to some form of surge protection device such as a power strip or Uninterruptible Power Supply (UPS). Not all power strips provide surge protection; the power strips must be specifically labeled as having this ability. Use a power strip whose manufacturer offers a Damage Replacement Policy so you can replace the equipment, if surge protection fails.

Use the appropriate and correctly sized furniture designed to properly support your HP LCD monitor.

 **WARNING!** LCD monitors that are inappropriately situated on dressers, bookcases, shelves, desks, speakers, chests, or carts may fall over and cause personal injury.

Care should be taken to route all cords and cables connected to the LCD monitor so that they cannot be pulled, grabbed, or tripped over.

Be sure that the total ampere rating of the products connected to the AC outlet does not exceed the current rating of the outlet, and that the total ampere rating of the products connected to the cord does not exceed the rating of the cord. Look on the power label to determine the ampere rating (AMPS or A) for each device.

Install the monitor near an AC outlet that you can easily reach. Disconnect the monitor by grasping the plug firmly and pulling it from the AC outlet. Never disconnect the monitor by pulling the cord.

Do not drop the monitor or place it on an unstable surface.

 **NOTE:** This product is suitable for entertainment purposes. Consider placing the monitor in a controlled luminous environment to avoid interference from surrounding light and bright surfaces that may cause disturbing reflections from the screen.

Product features and components

Features

The monitor features include the following:

- 88.9 cm (35-inch) diagonal viewable area with 3440 × 1440 UWQHD resolution, plus full-screen support for lower resolutions
- Tilt and height-adjustment capability
- Wide viewing angle technology and curved arc to provide an immersive viewing experience with increased field of vision, enhanced peripheral readability, and improved visual perception
- HDMI (High-Definition Multimedia Interface) video input
- DisplayPort video input
- HDCP (High-bandwidth Digital Content Protection) used on digital inputs
- USB 3.0 hub with one upstream port and three downstream charging ports
- Audio headphone/variable line-out jack
- DisplayPort, HDMI, and USB Type-B to Type-A cables included
- Plug and Play capability, if supported by your operating system
- On-screen display (OSD) adjustments in several languages for easy setup and screen optimization
- Software and documentation disc that includes monitor drivers and product documentation
- VESA mounting bracket for attaching the monitor to a wall-mount device or swing arm
- Security cable slot provision on rear of monitor for optional security cable
- User configurable ambient lighting with full-range LEDs
- Convenient headphones storage hook on monitor stand
- NVIDIA G-SYNC™ technology with high refresh rates, providing PC gaming advantages in reaction time and a more true-to-life experience
 - Smoothness is achieved by synchronizing display refresh rates to the GPU in your GeForce GTX-powered desktop or notebook, eliminating screen tearing and minimizing display stutter and input lag
 - Scenes appear instantly, objects look sharper, and game play is super smooth, giving you a stunning visual experience and a serious competitive edge



NOTE: For safety and regulatory information, refer to the *Product Notices* provided in your documentation kit. To locate updates to the user guide for your product, go to <http://www.hp.com/support>. Select **Find your product**, and then follow the on-screen instructions.

Identifying rear and side components

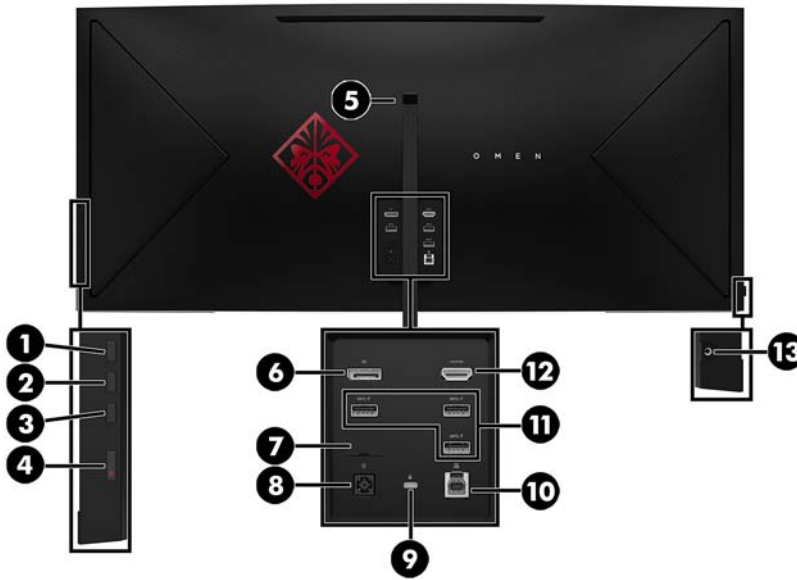

Component	Description
(1) Menu button	Press to open the OSD menu, select a menu item from the OSD, or close the OSD menu.
(2) Plus button	If the OSD menu is open, press to navigate forward through the OSD menu and increase adjustment levels. If the OSD menu is closed, press to open the Viewing Modes menu.
(3) Minus button	If the OSD menu is open, press to navigate backward through the OSD menu and decrease adjustment levels. If the OSD menu is closed, press to switch to the next input source.
(4) Power button	Turns the monitor on or off.
(5) Headphones hook	Provides a convenient storage location for headphones.
(6) DisplayPort	Connects the DisplayPort cable to the source device.
(7) Service port	Used by qualified HP service technicians only.
(8) Power connector	Connects an AC adapter.
(9) Security cable slot	Attaches an optional security cable to the monitor.
(10) USB 3.0 Type-B port	Connects the USB hub cable to the source device.
(11) USB 3.0 Type-A ports with HP Sleep and Charge (3)	Connect USB devices, provide high-speed data transfer, and charge products such as a cell phone, camera, activity tracker, or smartwatch, even when the computer is off.
(12) HDMI port	Connects the HDMI cable to the source device.
(13) Audio-out (headphone) jack	Connects headphones to the monitor. WARNING! To reduce the risk of personal injury, adjust the volume before using headphones, earbuds, or a headset. For additional safety information, see the <i>Product Notices</i> provided on the optical disc, if one is included with your product.

Setting up the monitor

Removing the stand's hinge blocker

The monitor is shipped with a hinge blocker that locks the display head in the lowest height position on the stand. You must remove the hinge blocker to adjust the height of the display head.

To remove the hinge blocker, gently press down the display head (1) and pull the hinge blocker out of the stand (2).

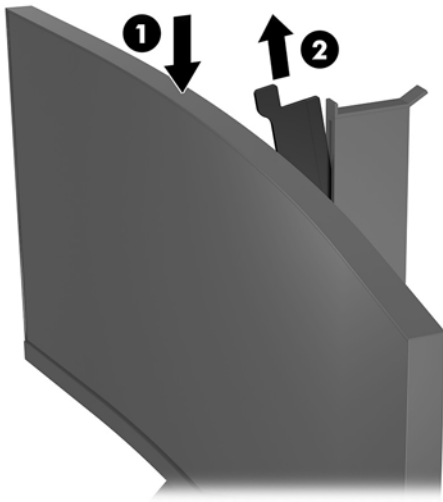

Connecting the cables

 **NOTE:** The monitor ships with select cables.

1. Place the monitor in a convenient, well-ventilated location near the computer.
2. Connect a video cable.

 **NOTE:** The monitor will automatically determine which inputs have valid video signals. The inputs can also be selected by pressing the Menu button on the side of the monitor and selecting **Input Control**.

- Connect one end of an HDMI cable to the HDMI port on the rear of the monitor and the other end to the HDMI port on the source device.

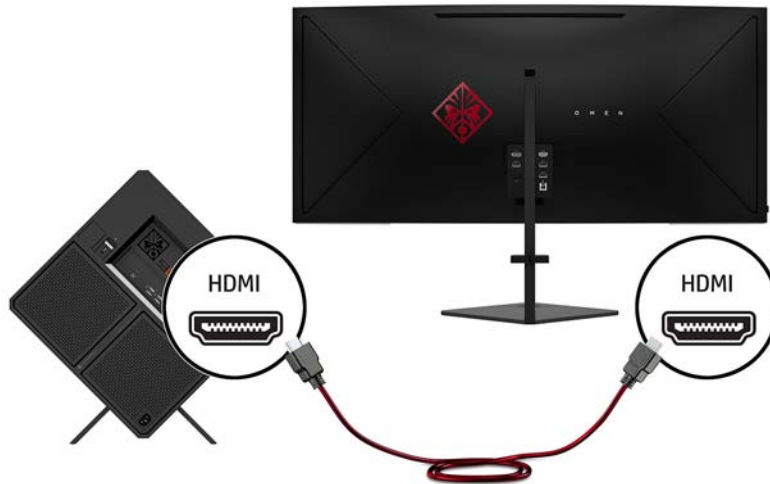

- Connect one end of a DisplayPort cable to the DisplayPort port on the rear of the monitor and the other end to the DisplayPort port on the source device.

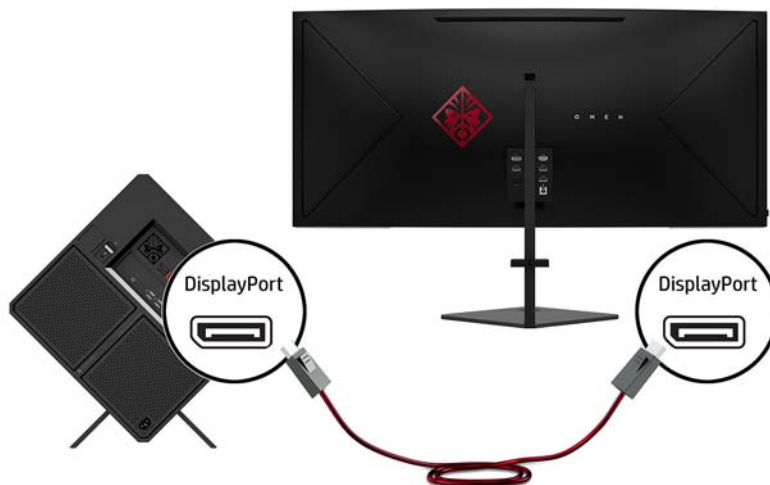

3. Connect one end of a Mini DisplayPort cable to the DisplayPort port on the rear of the monitor and the other end to the Mini DisplayPort port on the source device (cable not provided).

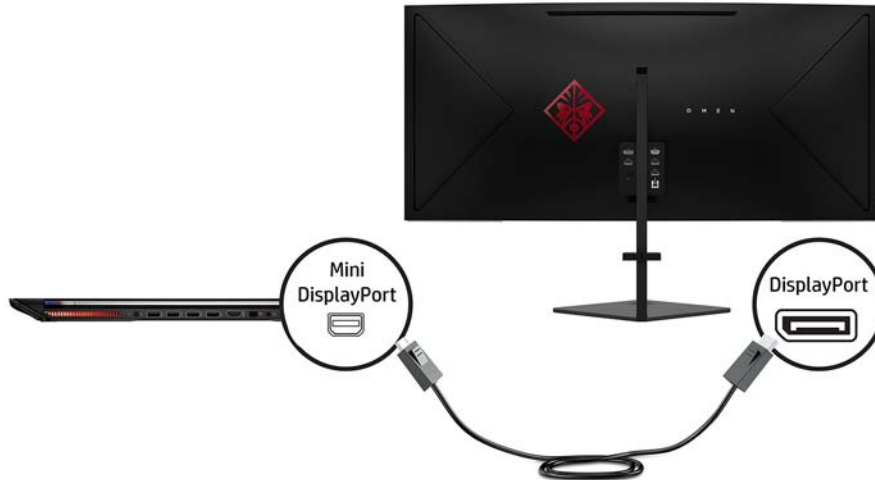

4. Connect the Type-B connector on the USB upstream cable to the USB upstream port on the rear of the monitor. Then connect the cable's Type-A connector to the USB downstream port on the source device.



5. Connect one end of the power cord to the AC adapter (1) and the other end to a grounded electrical outlet (2), and then connect the AC adapter to the monitor (3).



⚠ WARNING! To reduce the risk of electric shock or damage to the equipment:

Do not disable the power cord grounding plug. The grounding plug is an important safety feature.

Plug the power cord into a grounded (earthed) AC outlet that is easily accessible at all times.

Disconnect power from the equipment by unplugging the power cord from the electrical outlet.

For your safety, do not place anything on power cords or cables. Arrange them so that no one may accidentally step on or trip over them. Do not pull on a cord or cable. When unplugging from the AC outlet, grasp the cord by the plug.

6. Route the cables through the cable management clip on the rear of the monitor.



Connecting USB devices

The rear of the monitor provides one USB Type-B upstream port and three USB Type-A downstream ports.

 **NOTE:** You must connect the USB upstream cable from the source device to the monitor to enable the USB downstream ports on the monitor.

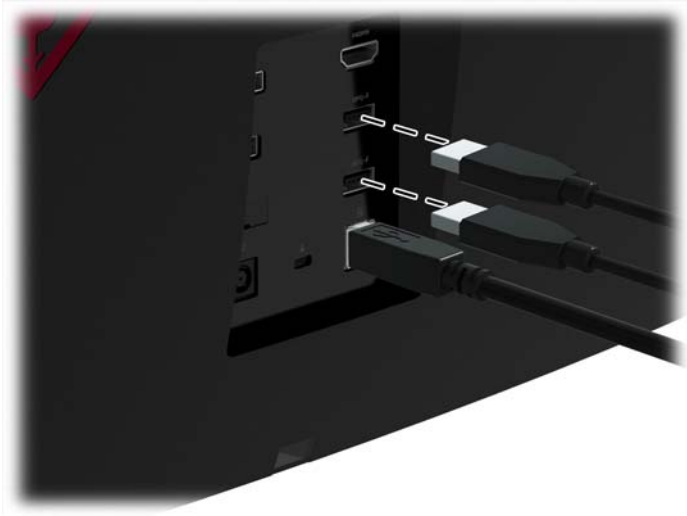

Adjusting the monitor for comfort

Tilt the display head forward or backward to set it to a comfortable eye level.



Adjust the display head up or down to set it to a comfortable eye level.

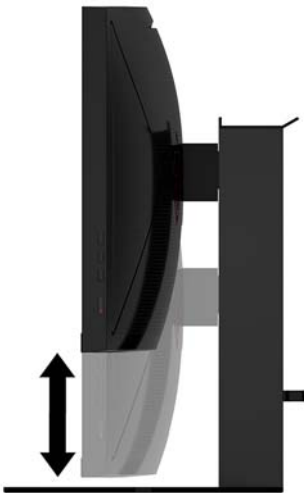

Turning on the monitor

1. Press the power button on the source device to turn it on.
2. Press the power button on the side of the monitor to turn it on.



 **IMPORTANT:** Burn-in image damage may occur on monitors that display the same static image on the screen for 12 or more consecutive hours of nonuse. To avoid burn-in image damage on the monitor screen, you should always activate a screen saver application or turn off the monitor when it is not in use for a prolonged period of time. Image retention is a condition that may occur on all LCD screens. Monitors with a “burned-in image” are not covered under the HP warranty.

 **NOTE:** You can disable the power light in the OSD menu. Press the Menu button on the side of the monitor, and then select **Power Control > Power LED > Off**.

The monitor automatically scans the signal inputs for an active input and uses that input for the display.

Installing a security cable

You can secure the monitor to a fixed object with an optional security cable available from HP.

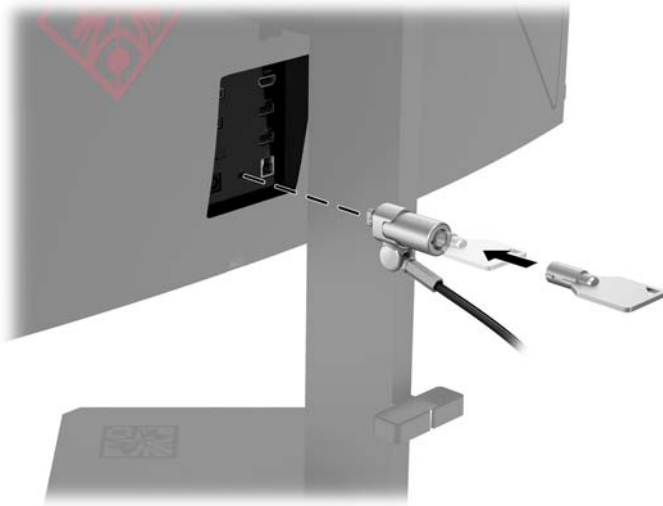

Storing headphones

The monitor features a headphone hook at the top of the stand for convenient headphones storage.



Using the ambient light

The monitor features an ambient light to illuminate a desk top or wall and enhance the gaming experience. You can adjust the light or turn it off in the OSD. Press the Menu button on the side of the monitor, and then select **Power Control > Ambient Lighting**.

You can change the color of the ambient lighting to match LED lighting on computer, keyboard, and mouse. You can also change the screen glow to output the average color on the display, expanding the on-screen action beyond the display.



Mounting the display head

The display head can be attached to a wall, swing arm, or other mounting fixture.

 **NOTE:** This apparatus is intended to be supported by UL or CSA Listed wall-mount bracket.

 **IMPORTANT:** This VESA mount kit supports the VESA industry standard 100 mm mounting holes. To attach a third-party mounting solution to the VESA mount, four 4 mm, 0.7 pitch, and 10 mm long screws are required. Longer screws must not be used because they may damage the monitor. It is important to verify that the manufacturer's mounting solution is compliant with the VESA standard and is rated to support the weight of the monitor display panel. For best performance, it is important to use the power and video cables provided with the monitor.

Removing the monitor stand

You can remove the display head from the stand to install the display head on a wall, a swing arm, or other mounting fixture.

 **IMPORTANT:** Before beginning to disassemble the monitor, be sure the monitor is turned off and all cables are disconnected.

1. Disconnect and remove all cables from the monitor.
2. Loosen the captive screws on the underside of the stand's hinge (1), and then slide the display head off the stand (2).

 **IMPORTANT:** Do not lay the monitor face down when removing the stand. Stress on the curvature of the display panel may damage the panel if the monitor is placed face down when removing the stand.

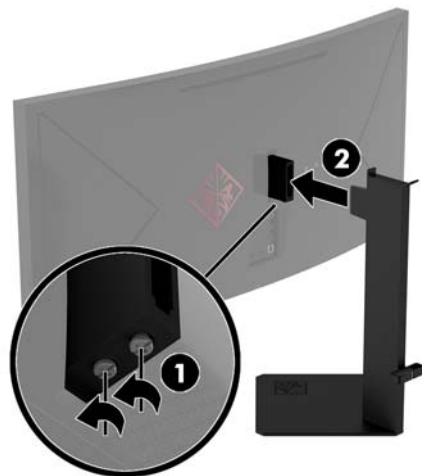

3. Lay the display head face down on a surface covered by a soft, clean cloth.



Attaching the VESA mounting bracket

A VESA mounting bracket is included with the monitor for use when attaching the display head to a wall, swing arm, or other mounting fixture.

1. Remove the monitor stand. Refer to [Removing the monitor stand on page 13](#).
2. Insert the VESA mounting bracket into the slot on the back of the display head's hinge (1), and then tighten the screws to secure the bracket (2).

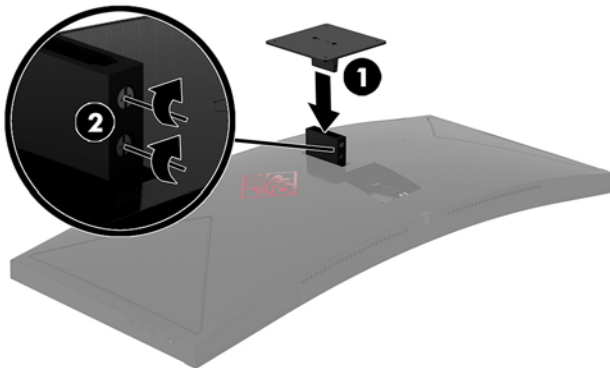

3. To attach the display head to a swing arm or other mounting device, insert four mounting screws through the holes on the mounting device and into the screw holes on the VESA mounting bracket.

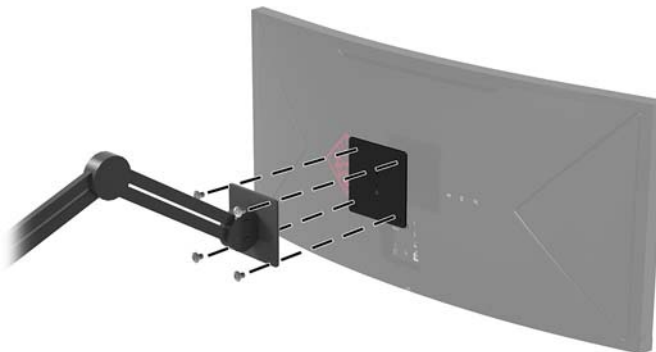

 **IMPORTANT:** Follow the mounting device manufacturer's instructions when mounting the monitor to a wall or swing arm.

IMPORTANT: For optimal monitor performance and screen clarity, do not rotate the monitor 90 degrees to portrait orientation.

2 Using the monitor

Software and utilities

The NVIDIA control panel software must be downloaded and installed from <http://www.geforce.com/drivers>. In order to use NVIDIA G-SYNC, you must have a G-SYNC compatible graphics card. A list of compatible cards is available at <http://www.geforce.com/hardware/technology/g-sync/supported-gpus>.

The optical disc, if one is included with the monitor, contains files that you can install on the computer. If you do not have an optical drive, you can download the files from <http://www.hp.com/support>.

- .Inf (Information) file
- .Icm (Image Color Matching) files (one for each calibrated color space)

Enabling G-SYNC

To enable the monitor for G-SYNC:

1. Right click on the Windows® Desktop and select **NVIDIA Control Panel**.
2. Select **Display** from the links on the left and choose **Set up G-SYNC**.
3. Check the box titled **Enable G-SYNC**.

The Setup Information file

The .inf file defines monitor resources used by Windows operating systems to ensure monitor compatibility with the computer's graphics adapter.

This monitor is Windows Plug and Play-compatible, and the monitor will work correctly without installing the .inf file. Monitor Plug and Play compatibility requires that the computer's graphic card is VESA DDC2-compliant and that the monitor connects directly to the graphics card. Plug and Play does not work through separate BNC-type connectors or through distribution buffers/boxes.

The Image Color Matching file

The .icm files are data files that are used in conjunction with graphics programs to provide consistent color matching from monitor screen to printer, or from scanner to monitor screen. This file is activated from within graphics programs that support this feature.



NOTE: The ICM color profile is written in accordance with the International Color Consortium (ICC) Profile Format specification.

Installing the .inf and .icm files

After you determine that you need to update, you can install the .inf and .icm files from the optical disc, if one is included, or download them.

Installing from the optical disc (available in select regions)

To install the .inf and .icm files on the computer from the optical disc, if one is provided:

1. Insert the optical disc in the computer optical drive. The optical disc menu is displayed.
2. View the **HP Monitor Software Information** file.
3. Select **Install Monitor Driver Software**.
4. Follow the on-screen instructions.
5. Ensure that the proper resolution and refresh rates appear in the Windows Display control panel.

Downloading from the web

If you do not have a computer or source device with an optical drive, you can download the latest version of .inf and .icm files from the HP monitors support website.

1. Go to <http://www.hp.com/support>.
2. Select **Get software and drivers**.
3. Follow the on-screen instructions to select your monitor and download the software.

Using the on-screen display (OSD) menu

Use the on-screen display (OSD) menu to adjust the screen image based on your viewing preferences. You can access and make adjustments in the OSD using the buttons on the right side of the monitor.

To access the OSD and make adjustments, do the following:

1. If the monitor is not already on, press the power button to turn on the monitor.
2. To access the OSD menu, press the Menu button on the right side of the monitor.
3. To navigate through the OSD menu, press the Plus button on the monitor's side panel to scroll up, or the Minus button to scroll down.
4. To select an item from the OSD menu, use the Plus or Minus buttons to scroll to and highlight your selection, then press the Menu button to select that function.
5. Adjust the item using the Plus or Minus buttons to adjust the scale.
6. After adjusting the function, select **OK** to save the setting, and then select **Exit** from the Main menu.

Main menu	Description
Luminance	Adjusts the brightness level of the screen. The factory default is 100.
Color Control	Selects and adjusts the screen color and viewing modes.
Input Control	Selects the video input signal (DisplayPort or HDMI).
Image Control	Adjusts the screen image and response time.
Power Control	Adjusts the power settings and ambient lighting.

Main menu	Description
Menu Control	Adjusts the on-screen display (OSD) controls.
Management	Returns all OSD menu settings to the factory default settings.
Language	Selects the language in which the OSD menu is displayed.
Information	Selects and displays important information about the monitor.
Exit	Exits the OSD menu screen.

Selecting a faster response time for gaming

To set a faster response time:

1. Open the OSD menu.
2. Select **Image Control** and then select **Response Time**.
3. Select one of the following levels from the **Response Time** menu:

Level 1

Level 2 (Fast)

Level 3 (Default)

Level 4

Level 5

Level 6 (Fastest)



NOTE: The default response time setting is optimized for G-SYNC gaming purposes. The response time can be adjusted to as low as 3 ms in the display menu. All performance specifications represent the typical specifications provided by HP's component manufacturers; actual performance may vary either higher or lower.

Using Deep Sleep mode



The monitor supports an OSD option called Deep Sleep that allows you to enable or disable a reduced power state for the monitor. When Deep Sleep mode is enabled (enabled by default), the monitor will enter a reduced power state when the host PC signals low power mode (absence of either horizontal or vertical sync signal) after 15 minutes.

Upon entering this reduced power state (sleep mode), after 15 minutes, the monitor screen is blanked, the backlight is turned off, and the power LED indicator turns amber. The monitor draws less than 0.5 W of power when in this reduced power state after 15 minutes. The monitor will wake from the sleep mode when the host computer sends an active signal to the monitor (for example, if you activate the mouse or keyboard).

You can disable Deep Sleep in the OSD. Press the Menu button on the right side of the monitor to open the OSD. In the OSD menu select **Power Control > DP Deep Sleep** or **HDMI Deep Sleep > Off**.

Selecting the Low Blue Light mode

Decreasing the blue light emitted by the display reduces the blue light exposure to your eyes. HP monitors provide settings to reduce the blue light output and create a more relaxing and less stimulating image while viewing content on the screen. To adjust your monitor to a comfortable viewing light, follow the steps below.

1. Press one of the OSD buttons on the monitor to display the OSD icons on the screen.
2. Select the Viewing Modes icon  to open the **Viewing Modes** menu, or select the Menu icon , and then select **Color Control > Viewing Modes**.
3. Choose one of the following settings:
 - Low Blue Light—Reduces blue light for improved eye comfort
 - Night—Adjusts the monitor to the lowest blue light output

3 Support and troubleshooting

Solving common problems

The following table lists possible problems, the possible cause of each problem, and the recommended solutions.

Problem	Possible Cause	Solution
Screen is blank or video is flashing.	Power cord is disconnected.	Connect the monitor power cord.
	Monitor is turned off.	Press the side panel power button.
	Video cable is not connected.	Connect the video cable between the source device and monitor. Be sure the computer power is off while you connect the video cable. Refer to Connecting the cables on page 5 for more information.
	System is in sleep mode.	Press any key on the keyboard or move the mouse to exit sleep mode.
	Video card is incompatible.	Replace the video card or connect the video cable to one of the computer's onboard video sources. A list of compatible NVIDIA G-SYNC video cards is available at http://www.geforce.com/hardware/technology/g-sync/supported-gpus .
Image appears too dark.	Brightness is too low.	Open the OSD menu and select Luminance to adjust the brightness scale as needed.
Input Signal Not Found is displayed on screen.	Monitor video cable is disconnected.	Connect the appropriate video signal cable between the computer and monitor. Be sure that the computer power is off while connecting the video cable.
Input Signal Out of Range is displayed on screen.	Video resolution and/or refresh rate are set higher than what the monitor supports.	Change the settings to a supported setting (see Preset display resolutions on page 23).
The monitor is off but it did not seem to enter into a low-power sleep mode.	The monitor's sleep mode is disabled.	Open the OSD menu and select Power Control > DP Deep Sleep or HDMI Deep Sleep and set to On .
OSD Lockout is displayed.	The monitor's OSD Lockout function is enabled.	Press and hold the Menu button on the side panel for 10 seconds to disable the OSD Lockout function.

Menu button lockout

Holding down the Menu button for ten seconds will lock out the functionality of the button. You can restore the functionality by holding the button down again for ten seconds. This functionality is only available when the display is turned on, displaying an active signal, and the OSD is not active.

Contacting support

To resolve a hardware or software problem, go to <http://www.hp.com/support>. Use this site to get more information about your product, including links to discussion forums and instructions on troubleshooting. You can also find information on how to contact HP and open a support case.

Preparing to call technical support

If you can not solve a problem using the troubleshooting tips in this section, you may need to call technical support. Have the following information available when you call:

- Monitor product number
- Monitor serial number
- Purchase date on invoice
- Conditions under which the problem occurred
- Error messages received
- Hardware configuration
- Name and version of the hardware and software you are using

Locating the serial number and product number

The serial number and product number are located on a label on the bottom edge of the display head. You may need these numbers when contacting HP about the monitor model.



4 Maintaining the monitor

Maintenance guidelines

To enhance the performance and extend the life of the monitor:

- Do not open the monitor cabinet or attempt to service this product yourself. Adjust only those controls that are covered in the operating instructions. If the monitor is not operating properly or has been dropped or damaged, contact an authorized HP dealer, reseller, or service provider.
- Use only a power source and connection appropriate for this monitor, as indicated on the label/back plate of the monitor.
- Be sure the total ampere rating of the products connected to the outlet does not exceed the current rating of the electrical outlet, and the total ampere rating of the products connected to the cord does not exceed the rating of the cord. Look on the power label to determine the ampere rating (AMPS or A) for each device.
- Install the monitor near an outlet that you can easily reach. Disconnect the monitor by grasping the plug firmly and pulling it from the outlet. Never disconnect the monitor by pulling the cord.
- Turn the monitor off when not in use. You can substantially increase the life expectancy of the monitor by using a screen saver program and turning off the monitor when not in use.



NOTE: Monitors with a “burned-in image” are not covered under the HP warranty.

- Slots and openings in the cabinet are provided for ventilation. These openings must not be blocked or covered. Never push objects of any kind into cabinet slots or other openings.
- Do not drop the monitor or place it on an unstable surface.
- Do not allow anything to rest on the power cord. Do not walk on the cord.
- Keep the monitor in a well-ventilated area, away from excessive light, heat or moisture.

Cleaning the monitor

1. Turn off the monitor and unplug the power cord from the AC outlet.
2. Dust the monitor by wiping the screen and the cabinet with a soft, clean antistatic cloth.
3. For more difficult cleaning situations, use a 50/50 mix of water and Isopropyl alcohol.



IMPORTANT: Spray the cleaner onto a cloth and use the damp cloth to gently wipe the screen surface. Never spray the cleaner directly on the screen surface. It may run behind the bezel and damage the electronics.

IMPORTANT: Do not use cleaners that contain any petroleum-based materials such as benzene, thinner, or any volatile substance to clean the monitor screen or cabinet. These chemicals may damage the monitor.

Shipping the monitor

Keep the original packing box in a storage area. You may need it later if you move or ship the monitor.

A Technical specifications



NOTE: All specifications represent the typical specifications provided by HP's component manufacturers; actual performance may vary either higher or lower.

For the latest specifications or additional specifications on this product, go to <http://www.hp.com/go/quickspecs/> and search for your specific display model to find the model-specific QuickSpecs.

Specification	Measurement	
Display, wide-screen	88.9 cm	35 in
Type	AMVA+	
Viewable image size	88.9 cm, diagonal	35 in, diagonal
Tilt	-5° to 23°	
Height adjustment	130 mm	5.12 in
Weight		
Without stand	9.47 kg	20.88 lb
With stand	12.04 kg	26.55 lb
Dimensions (including stand)		
Height	41.0 cm	16.14 in
Depth	32.9 cm	12.95 in
Width	83.3 cm	32.80 in
Maximum graphic resolution	DP Max. 3440 × 1440 (100 Hz) HDMI Max. 3440 × 1440 (50 Hz)	
Optimum graphic resolution	DP Opt. 3440 × 1440 (60 Hz) HDMI Opt. 3440 × 1440 (50 Hz)	
Text mode	720 × 400	
Static contrast ratio	2,500:1 typical	
Dot pitch	0.2382 mm × 0.242 mm	
Pixels per inch	106 PPI	
Horizontal frequency	DP: 73-151 KHz, HDMI: 30-140 KHz	
Vertical refresh rate	DP: 30-100 Hz, HDMI: 24-60 Hz	
Response time	The default response time setting is optimized for G-SYNC gaming purposes. The response time can be adjusted to as low as 3 ms in the display menu. All performance specifications represent the typical specifications provided by HP's component manufacturers; actual performance may vary either higher or lower.	
Environmental requirements		
Temperature		
Operating temperature	5°C to 35°C	41°F to 95°F
Storage temperature	-20°C to 60°C	-4°F to 140°F

Specification	Measurement	
Relative humidity	20% to 70%	
Altitude	0 ft to 16,400 ft	
Operating	0 m to 5,000 m	0 ft to 40,000 ft
Storage	0 m to 12,192 m	
Power source	100 V ac to 240 V ac 50/60 Hz	
Measured power consumption		
Full power	120 W	
Typical settings	75 W	
Sleep	<0.5 W (after 15 minutes)	
Off	<0.5 W	
Input terminals	One HDMI port and one DisplayPort port	

Preset display resolutions

The display resolutions listed below are the most commonly used modes and are set as defaults. The monitor automatically recognizes these preset modes, and they will appear properly sized and centered on the screen.

Preset display resolutions
640 x 480 @ 60 Hz (DP+HDMI)
800 x 600 @ 60 Hz (DP+HDMI)
1024 x 768 @ 60 Hz (DP+HDMI)
3440 x 1440 @ 50 Hz (DP+HDMI)
3440 x 1440 @ 60 Hz / 85 Hz / 100 Hz (DP)
1080P (50/60 Hz) 720P (50/60 Hz) 576P 480P (DP+HDMI)

Entering user modes

The video controller signal may occasionally call for a mode that is not preset if:

- You are not using a standard graphics adapter.
- You are not using a preset mode.

If this occurs, you may need to readjust the parameters of the monitor screen by using the on-screen display. Your changes can be made to any or all of these modes and saved in memory. The monitor automatically stores the new setting, and then recognizes the new mode just as it does a preset mode. In addition to the factory preset modes, there are at least 10 user modes that can be entered and stored.

Power adapter

Manufacturer	Model number	Power supply rating
AcBel	TPC-AA501	19.5 V dc @ 9.23 A – 180 W

Energy saver feature

The monitor supports a reduced power state. The reduced power state will be entered into if the monitor detects the absence of either the horizontal sync signal and/or the vertical sync signal. Upon detecting the absence of these signals, the monitor screen is blanked, the backlight is turned off, and the power light turns amber. When the monitor is in the reduced power state, the monitor will utilize <0.5 watts of power. There is a brief warm-up period before the monitor will return to its normal operating state.

Refer to the computer manual for instructions on setting the energy saver mode (sometimes called power management feature).



NOTE: The above power saver feature only works when the monitor is connected to a computer that has energy saver features.

By selecting the settings in the monitor's Sleep Timer utility, you can also program the monitor to enter into the reduced power state at a predetermined time. When the monitor's Sleep Timer utility causes the monitor to enter the reduced power state, the power light blinks amber.

B Accessibility

HP designs, produces, and markets products and services that can be used by everyone, including people with disabilities, either on a stand-alone basis or with appropriate assistive devices.

Supported assistive technologies

HP products support a wide variety of operating system assistive technologies and can be configured to work with additional assistive technologies. Use the Search feature on your source device that is connected to the monitor to locate more information about assistive features.

 **NOTE:** For additional information about a particular assistive technology product, contact customer support for that product.

Contacting support

We are constantly refining the accessibility of our products and services and welcome feedback from users. If you have an issue with a product or would like to tell us about accessibility features that have helped you, please contact us at (888) 259-5707, Monday through Friday, 6 a.m. to 9 p.m. Mountain Time. If you are deaf or hard-of-hearing and use TRS/VRS/WebCapTel, contact us if you require technical support or have accessibility questions by calling (877) 656-7058, Monday through Friday, 6 a.m. to 9 p.m. Mountain Time.