



HP Pavilion x360 15 Convertible PC

Maintenance and Service Guide
IMPORTANT! This document is intended for
HP authorized service providers only.

© Copyright 2017 Hewlett-Packard
Development Company, L.P.

Bluetooth is a trademark owned by its proprietor and used by HP Inc. under license. Intel, Core, and Pentium are U.S. registered trademarks of Intel Corporation. Microsoft and Windows are either registered trademarks or trademarks of Microsoft Corporation in the United States and/or other countries. SD Logo is a trademark of its proprietor.

The information contained herein is subject to change without notice. The only warranties for HP products and services are set forth in the express warranty statements accompanying such products and services. Nothing herein should be construed as constituting an additional warranty. HP shall not be liable for technical or editorial errors or omissions contained herein.

Second Edition: August 2017

First Edition: April 2017

Document Part Number: 926167-002

Product notice

This guide describes features that are common to most models. Some features may not be available on your computer.

Not all features are available in all editions of Windows 10. This computer may require upgraded and/or separately purchased hardware, drivers and/or software to take full advantage of Windows 10 functionality. See for <http://www.microsoft.com> details.

Safety warning notice

 **WARNING!** To reduce the possibility of heat-related injuries or of overheating the device, do not place the device directly on your lap or obstruct the device air vents. Use the device only on a hard, flat surface. Do not allow another hard surface, such as an adjoining optional printer, or a soft surface, such as pillows or rugs or clothing, to block airflow. Also, do not allow the AC adapter to contact the skin or a soft surface, such as pillows or rugs or clothing, during operation. The device and the AC adapter comply with the user-accessible surface temperature limits defined by the International Standard for Safety of Information Technology Equipment (IEC 60950-1).

Table of contents

1 Product description	1
2 External component identification	4
Display	4
Speakers	5
TouchPad	5
Left side	6
Right side	7
Bottom	8
3 Illustrated parts catalog	9
Labels	9
Computer major components	10
Display assembly subcomponents	16
Miscellaneous parts	18
4 Removal and replacement preliminary requirements	19
Tools required	19
Service considerations	19
Plastic parts	19
Cables and connectors	19
Drive handling	20
Grounding guidelines	21
Electrostatic discharge damage	21
Packaging and transporting guidelines	22
Workstation guidelines	22
5 Removal and replacement procedures	24
Component replacement procedures	24
Keyboard/top cover	24
TouchPad cable	28
TouchPad	29
Battery	30
Hard drive	31
Audio jack board cable	33
Audio jack board	34

Power button board cable	35
Power button board	36
Speakers	37
System board	38
WLAN module	42
Fan/heat sink assembly	43
Memory module	45
Power connector cable	47
Display assembly	48
6 Computer Setup (BIOS), TPM, and HP Sure Start	58
Using Computer Setup	58
Starting Computer Setup	58
Navigating and selecting in Computer Setup	58
Restoring factory settings in Computer Setup	59
Updating the BIOS	60
Determining the BIOS version	60
Downloading a BIOS update	60
Changing the boot order using the f9 prompt	61
TPM BIOS settings (select products only)	62
Using HP Sure Start (select products only)	62
7 HP PC Hardware Diagnostics (UEFI)	63
Downloading HP PC Hardware Diagnostics (UEFI) to a USB device	64
8 Specifications	65
9 Power cord set requirements	66
Requirements for all countries	66
Requirements for specific countries and regions	66
10 Recycling	68
Index	69

1 Product description

Category	Description
Product Name	HP Pavilion x360 15 Convertible PC (model number 15-br1xx) HP Pavilion x360 15 Convertible PC (model number 15-br0xx)
Processors	For use only on computer models with model number 15-br1xx: <ul style="list-style-type: none">Intel® Core™ i7-8550U 1.80-GHz (SC turbo up to 4.00-GHz) quad core processor (8.0-GB L3 cache, 2400-MHz FSB, 15-W) For use on all computer models: <ul style="list-style-type: none">Intel Core i7-7500U 2.70-GHz (SC turbo up to 3.56-GHz) dual core processor (4.0-GB L3 cache, 2133-MHz FSB, 15-W)Intel Core i5-7200U 2.56-GHz (SC turbo up to 3.10-GHz) dual core processor (3.0-GB L3 cache, 2133-MHz FSB, 15-W)Intel Core i3-7100U 2.40-GHz dual core processor (3.0-GB L3 cache, 2133-MHz FSB, 15-W)Intel Pentium™ 4415U 2.36-GHz dual core processor (2.0-GB L3 cache, 2133-MHz FSB, 15-W)
Chipset	Integrated with soldered-on-circuit (SoC)
Graphics	Switchable discrete graphics: AMD Radeon® 530 R17M-M1-70 (Meso Pro) with up to 4096-MB of discrete video memory (512-MB×16 DDR3×4 pieces; available only on computer models equipped with an Intel Core i7-7500U processor) AMD Radeon 530 R17M-M1-70 (Meso Pro) with up to 2048-MB of discrete video memory (256-MB×16 DDR3×4 pieces; available only on computer models equipped with an Intel Core i5-7200U processor or an Intel Core i3-7100U processor) Internal graphics: Intel HD Graphics 620 (available only on computer models equipped with an Intel Core i5 processor or an Intel Core i3 processor) Intel HD Graphics (available only on computer models equipped with an Intel Pentium 4415U processor) Support for HD decode, DX12, and high-definition multimedia interface (HDMI)
Panel	15.6-in, full high-definition (FHD), white light-emitting (WLED), BrightView (1920×1080), slim/flat (3.2-mm), UWVA, eDP, 220 nits, 16:9 ultra wide aspect ratio TouchScreen display assembly 15.6-in, high-definition (HD), WLED, AntiGlare (1366×768), slim/flat (3.2-mm), SVA, eDP, 220 nits, 16:9 ultra wide aspect ratio TouchScreen display assembly Support for active stylus
Memory	Two SODIMM memory module slots, non-customer-accessible/non-upgradable Supports up to 16-GB of system memory DDR4-2133 dual channel support (DDR4-2400 downgrade to DDR4-2133) Supports the following configurations: <ul style="list-style-type: none">16384 MB (8192 MB × 2)8192 MB (8192 MB × 1)6144 MB (4096 MB + 2048 MB)

Category	Description
Memory <i>(continued)</i>	<ul style="list-style-type: none"> 4096 MB (4096 MB × 1)
Storage	<p>Single hard drive configurations:</p> <p>1-TB, 5400-rpm, 7.2-mm hard drive</p> <p>500-GB, 5400-rpm, 7.0-mm hard drive</p> <p>Solid-state hard drive configurations:</p> <p>1-TB, 5400-rpm, 7.2-mm solid-state hard drive with 8-GB NAND</p> <p>500-GB, 5400-rpm, 7.0-mm solid-state hard drive with 8-GB NAND</p> <p>Solid-state drive:</p> <p>Support for M.2 SATA solid-state drive (support for storage function, port 1; not available on computer models equipped with an Intel Pentium processor)</p> <p>Support for Serial Advanced Technology Attachment (SATA)</p> <p>Support for hard drive and solid-state drive</p> <p>For use only on computer models with model number 15-cc7xx:</p> <ul style="list-style-type: none"> 512-GB, 2280, Peripheral Component Interconnect Express (PCIe), Non-Volatile Memory Express (NVMe) solid-state drive 256-GB, 2280, PCIe, NVMe solid-state drive <p>For use on all computer models:</p> <p>M.2 SATA-3 solid-state drive with Triple-Level Cell (TLC):</p> <ul style="list-style-type: none"> 512-GB 256-GB 128-GB <p>M.2 SATA-3 solid-state drive: 256-GB and 128-GB</p> <p>Dual storage configurations (not available on computer models equipped with an Intel Pentium processor):</p> <p>1-TB, 5400-rpm, 7.2-mm hard drive with 128-GB M.2 SATA-3 solid-state drive</p> <p>500-GB, 5400-rpm, 7.0-mm hard drive with 128-GB M.2 SATA-3 solid-state drive</p>
Optical drive	HP external DVD±RW DL SuperMulti Drive
Audio and video	<p>Support for the following cameras:</p> <p>HP Wide Vision FHD infrared camera with indicator light and 2 infrared lights, USB 2.0, FHD hybrid BSI sensor, f2.2, WDR, 88° wide field of vision, 1080p by 30 frames per second (available only on computer models equipped with an FHD display assembly, an Intel I7 processor and a graphics subsystem with discrete video memory and computer models equipped with an FHD display assembly and an Intel Pentium processor)</p> <p>HP Wide Vision HD camera with indicator light, USB 2.0, HD BSI sensor, f2.0, WDR, 88° wide field of vision, 720p by 30 frames per second</p> <p>Support for B&O Play</p> <p>Support for B&O Play Audio Control</p> <p>Support for dual-array digital microphones with appropriate beam-forming, echo-cancellation, noise-suppression software</p> <p>Support for dual speakers</p> <p>Support for HP Audio Boost</p>

Category	Description
Audio and video <i>(continued)</i>	Support for Windows Hello
Sensors	<ul style="list-style-type: none"> Accelerometer (ST Micro HP2DC) Gyroscope/E-compass/Accelerometer (ST Micro HP9DS1) Integrated sensor hub
Wireless	<p>WLAN:</p> <p>Integrated wireless local area network (WLAN) options by way of wireless module</p> <p>Two M.2/PCIe WLAN antennas built into display assembly</p> <p>Integrated wireless personal area network (PAN) supported by Bluetooth® 4.2 combo card</p> <p>Support for the Intel Dual Band Wireless-AC 7265 802.11 AC 2×2 WiFi + Bluetooth 4.2 Combo Adapter (non-vPro) and Intel Dual Band Wireless-AC 3168 802.11 AC 1×1 WiFi + Bluetooth 4.2 Combo Adapter (non-vPro) formats</p>
External media cards	Micro-Secure Digital (SD®) media reader slot
Ports	<ul style="list-style-type: none"> AC Smart Pin adapter plug Audio-out (headphone)/audio-in (microphone) combo jack HDMI v1.4 supporting up to 1920×1080 @ 60Hz USB 3.x ports (2) USB Type-C port
Keyboard/pointing devices	<p>Full-sized, three-coat, backlit, island-style keyboard with numeric keypad</p> <p>TouchPad requirements:</p> <ul style="list-style-type: none"> ClickPad with image sensor MultiTouch gestures enabled Support for Modern TrackPad gestures Taps enabled as default
Power requirements	<p>Support for a 3-cell, 48-WWhr, 4.2-AHr, Li-ion battery</p> <p>Support for the following AC adapters:</p> <ul style="list-style-type: none"> 90-W AC adapter (PFC, S-3P, 4.5-mm) 65-W HP Smart AC adapter (non-PFC, EM, RC, 4.5-mm) 65-W AC adapter (non-PFC, S-3P, 4.5-mm) 45-W HP Smart AC adapter (non-PFC, RC, 4.5-mm, non-slim) <p>Support for a 1.00-m power cord with a C5 connector in 12 countries/regions.</p>
Security	<p>Security cable lock slot</p> <p>Support for Trusted Platform Module (fTPM) 2.0 (firmware-based)</p>
Operating system	<p>Preinstalled: Windows 10 and Windows 10 Professional</p> <p>For developed market (ML): Windows 10 Home ML and Windows 10 Home Plus ML</p> <p>For emerging market (EM/SL): Windows 10 Home EM/SL and Windows 10 Home Plus EM/SL</p>
Serviceability	End user replaceable part: AC adapter

2 External component identification

Display

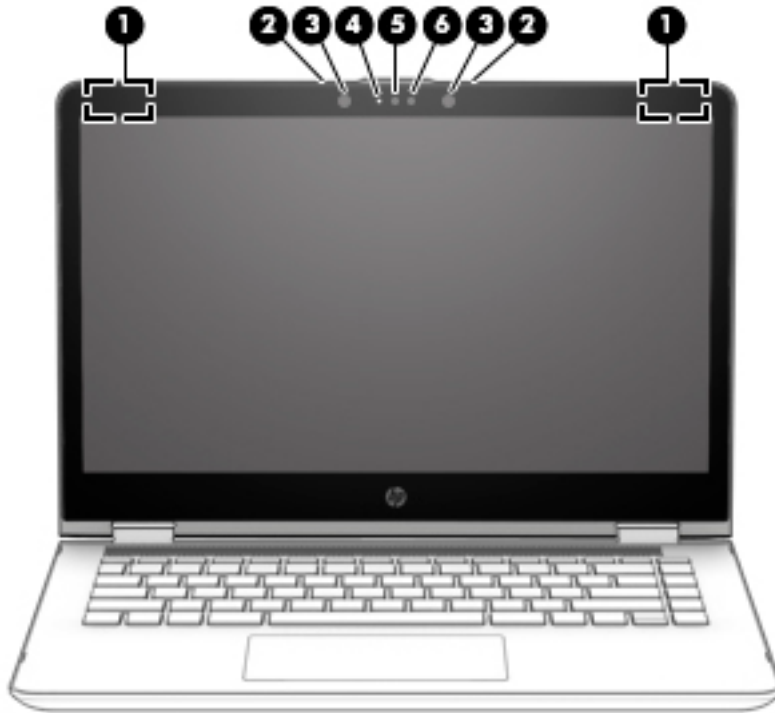

Item	Component	Description
(1)	WLAN antennas (2)*	Send and receive wireless signals to communicate with WLANs. NOTE: The position of the WLAN antennas may differ, depending on model.
(2)	Internal microphone	Records sound.
(3)	Webcam	Records video, captures still photographs, and allows video conferences and online chat by means of streaming video.
(4)	Webcam light	On: The webcam is in use.
(5)	Internal display switch	Turns off the display or initiates Sleep if the display is closed while the power is on. NOTE: The display switch is not visible from the outside of the computer.

*The antennas, IR emitters (select models only), and sensors are not visible from the outside of the computer. For optimal transmission, keep the areas immediately around the antennas, IR emitters, and sensors free from obstructions. For wireless regulatory notices, see the section of the *Regulatory, Safety, and Environmental Notices* that applies to your country or region.

Speakers

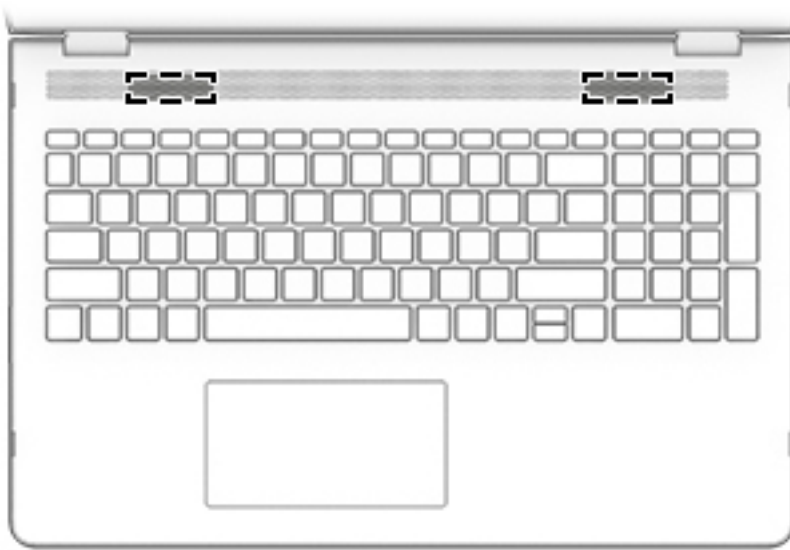

Item	Component	Description
(1)	Speakers	Produce sound.

TouchPad

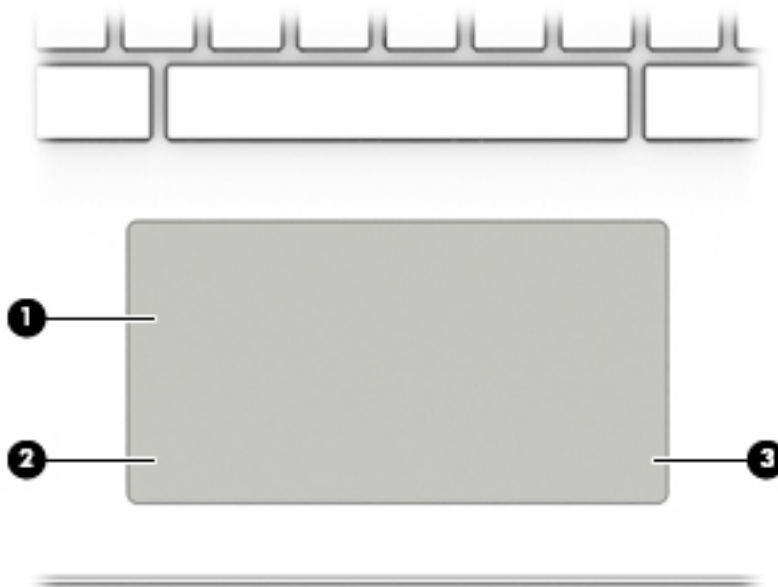

Item	Component	Description
(1)	TouchPad zone	Moves the on-screen pointer and selects or activates items on the screen.
(2)	Left control zone	Textured area that allows you to perform additional gestures.
(3)	Right control zone	Textured area that allows you to perform additional gestures.

Left side

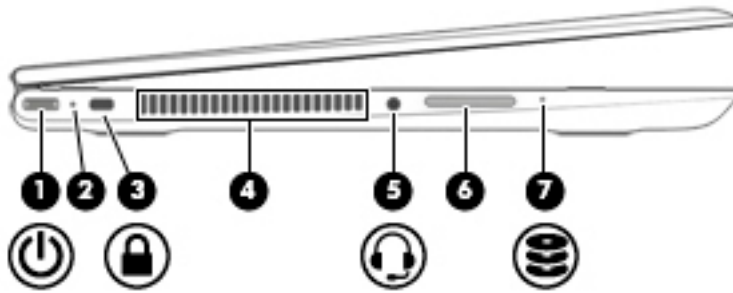

Item	Component	Description
(1)	Security cable slot	Attaches an optional security cable to the computer. NOTE: The security cable is designed to act as a deterrent, but it may not prevent the computer from being mishandled or stolen.
(2)	Power connector	Connects an AC adapter.
(3)	AC adapter light	<ul style="list-style-type: none">White: The AC adapter is connected and the battery is charged.Amber: The AC adapter is connected and the battery is charging.Off: The computer is using battery power.
(4)	Memory card reader	Reads optional memory cards that store, manage, share, or access information. To insert a card: <ul style="list-style-type: none">▲ Hold the card label-side up, with connectors facing the slot, insert the card into the slot, and then push in on the card until it is firmly seated. To remove a card: <ul style="list-style-type: none">▲ Press in on the card it until it pops out.

Right side

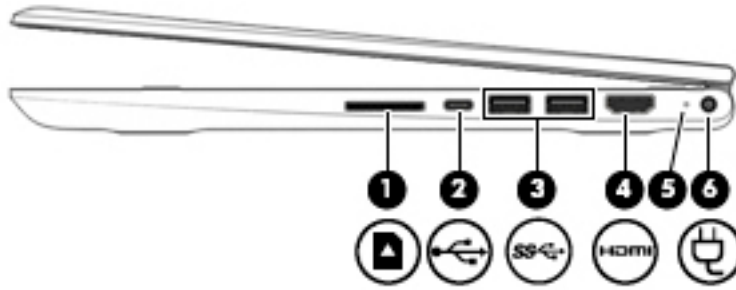

Item	Component	Description
(1)	Power light	<ul style="list-style-type: none"> White: Computer is on. Blinking white: Computer is in Sleep mode. Off: The computer is off.
(2)	Audio-out (headphone)/Audio-in (microphone) jack	<p>Connects optional powered stereo speakers, headphones, earbuds, a headset, or a television audio cable. Also connects an optional headset microphone. This jack does not support optional microphone-only devices.</p> <p>WARNING! To reduce the risk of personal injury, adjust the volume before putting on headphones, earbuds, or a headset.</p> <p>NOTE: When a device is connected to the jack, the computer speakers are disabled.</p> <p>NOTE: Be sure that the device cable has 4-conductor connector that supports both audio-out (headphone) and audio-in (microphone).</p>
(3)	USB 2.0 port	Connect optional USB devices, such as a keyboard, mouse, external drive, printer, scanner or USB hub.
(4)	USB 3.0 charging (powered) port	Connects an optional USB device, such as a keyboard, mouse, external drive, printer, scanner or USB hub. Standard USB ports will not charge all USB devices or will charge using a low current. Some USB devices require power and require you to use a powered port.
(5)	HDMI port	Connects an optional video or audio device, such as a high-definition television, any compatible digital or audio component, or a high-speed High-Definition Multimedia Interface (HDMI) device.

Bottom

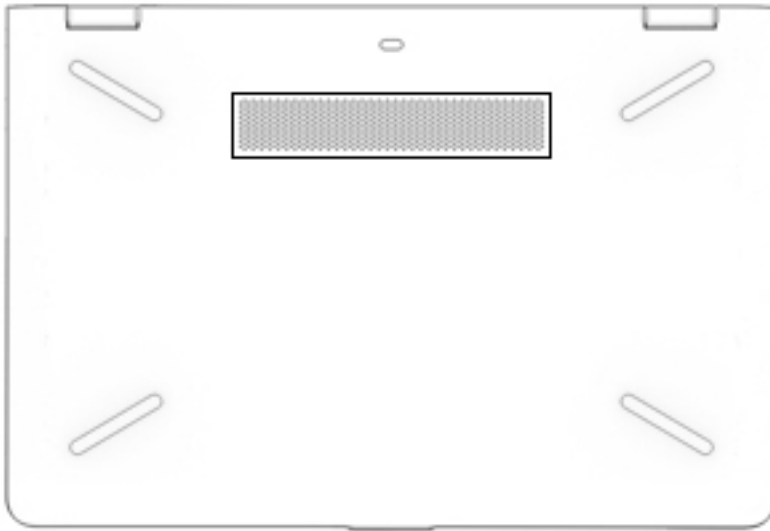

Item	Component	Description
(1)	Speakers (2)	Produce sound.

3 Illustrated parts catalog

NOTE: HP continually improves and changes product parts. For complete and current information on supported parts for your computer, go to <http://partsurfer.hp.com>, select your country or region, and then follow the on-screen instructions.

Labels

The labels affixed to the computer provide information that may be needed when troubleshooting system problems or travelling internationally with the computer.

IMPORTANT: Check the following locations for the labels described in this section: the bottom of the computer, inside the battery bay, under the service door, on the back of the display, or on the bottom of a tablet kickstand.

- Service label—Provides important information to identify your computer. When contacting support, you may be asked for the serial number, the product number, or the model number. Locate this information before you contact support.

Your service label will resemble one of the examples shown below. Refer to the illustration that most closely matches the service label on your computer.

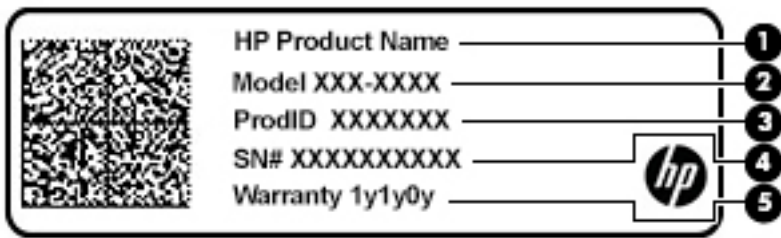

Component

- | | |
|-----|--|
| (1) | HP product name (select products only) |
| (2) | Model number |
| (3) | Product number |
| (4) | Serial number |
| (5) | Warranty period |

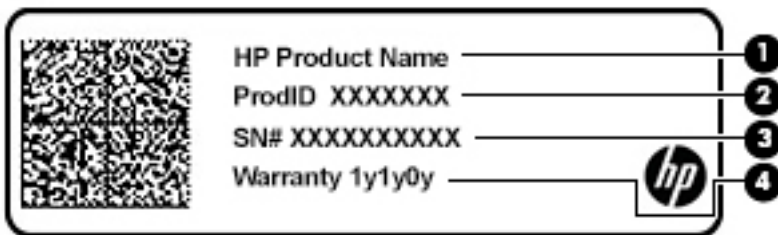

Component	
(1)	HP product name (select products only)
(2)	Product number
(3)	Serial number
(4)	Warranty period

Computer major components

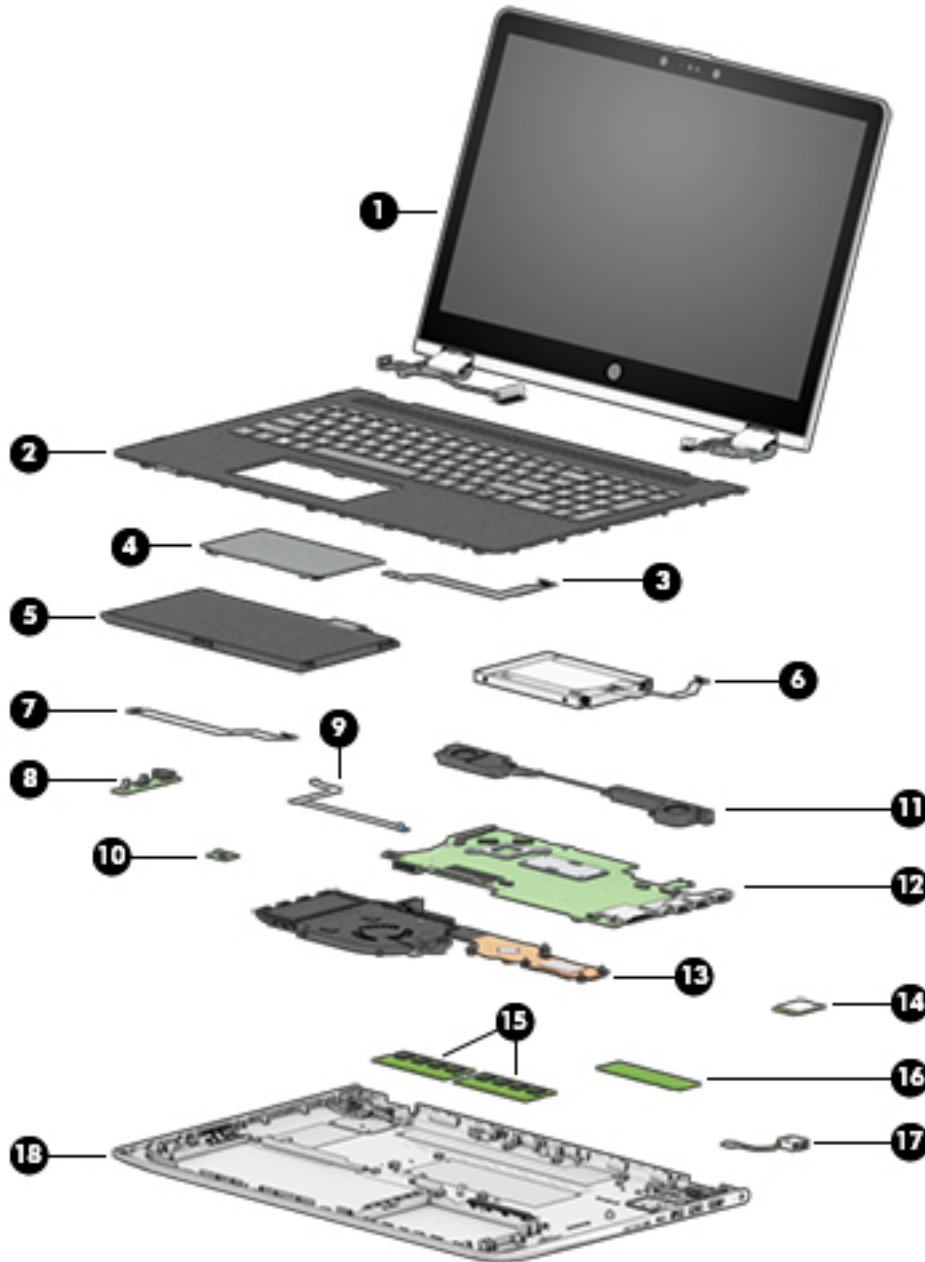

Item	Component	Spare part number
(1)	Display assembly: The display assembly is spared at the subcomponent level only. For more display assembly spare part information, see Display assembly subcomponents on page 16 .	
(2)	Keyboard/top cover	
	In ash silver finish with backlight for use only on computer models equipped with a graphics subsystem with discrete memory (includes backlight cable and keyboard cable):	
	For use in Canada	924525-DB1
	For use in the United States	924525-001
	In ash silver finish with backlight for use only on computer models equipped with a graphics subsystem with UMA memory (includes backlight cable and keyboard cable):	
	For use in Canada	924524-DB1
	For use in the United States	924524-001
	Keyboard/top cover	
	In ash silver finish for use only on computer models equipped with a graphics subsystem with discrete memory (includes keyboard cable):	
	For use in Belgium	924523-A41
	For use in Bulgaria	924523-261
	For use in Canada	924523-DB1
	For use in the Czech Republic and Slovakia	924523-FL1
	For use in Denmark, Finland, and Norway	924523-DH1
	For use in France	924523-051
	For use in Germany	924523-041
	For use in Greece	924523-151
	For use in Hungary	924523-211
	For use in India	924523-002
	For use in Israel	924523-BB1
	For use in Italy	924523-061
	For use in Latin America	924523-161
	For use in the Netherlands	924523-B31
	For use in Portugal	924523-131
	For use in Romania	924523-271
	For use in Russia	924523-251
	For use in Saudi Arabia	924523-171
	For use in Slovenia	924523-BA1
	For use in Spain	924523-071
	For use in Switzerland	924523-BG1
	For use in Turkey	924523-141

Item	Component	Spare part number
	For use in the United Kingdom	924523-031
	For use in the United States	924523-001
	Keyboard/top cover	
	In ash silver finish for use only on computer models equipped with a graphics subsystem with UMA memory (includes keyboard cable):	
	For use in Belgium	924522-A41
	For use in Bulgaria	924522-261
	For use in Canada	924522-DB1
	For use in the Czech Republic and Slovakia	924522-FL1
	For use in Denmark, Finland, and Norway	924522-DH1
	For use in France	924522-051
	For use in Germany	924522-041
	For use in Greece	924522-151
	For use in Hungary	924522-211
	For use in India	924522-002
	For use in Israel	924522-BB1
	For use in Italy	924522-061
	For use in Latin America	924522-161
	For use in the Netherlands	924522-B31
	For use in Portugal	924522-131
	For use in Romania	924522-271
	For use in Russia	924522-251
	For use in Saudi Arabia	924522-171
	For use in Slovenia	924522-BA1
	For use in Spain	924522-071
	For use in Switzerland	924522-BG1
	For use in Turkey	924522-141
	For use in the United Kingdom	924522-031
	For use in the United States	924522-001
(3)	TouchPad cable (includes double-sided adhesive)	924509-001
(4)	TouchPad (does not include TouchPad bracket or TouchPad cable)	924529-001
	NOTE: The TouchPad bracket is available using spare part number 924517-001. The TouchPad cable is available using spare part number 924509-001.	
	TouchPad bracket (not illustrated)	924517-001
(5)	Battery (3-cell, 48-WHr, 4.2-AHr, Li-ion)	916812-855

Item	Component	Spare part number
(6)	Hard drive (does not include hard drive rubber sleeve):	
	1-TB, 5400-rpm, SATA, 8-GB hybrid hard drive	924036-856
	1-TB, 5400-rpm, SATA hard drive	762888-859
	500-GB, 5400-rpm, SATA, 8-GB hybrid hard drive	731863-858
	500-GB, 5400-rpm, SATA hard drive	683839-859
	NOTE: The hard drive rubber sleeve is available using spare part number 924515-001.	
	Hard drive counterbalance weight (not illustrated)	934083-001
(7)	Audio jack board cable (includes double-sided adhesive)	924510-001
(8)	Audio jack board (includes audio jack, volume control actuators, and hard drive activity light; does not include audio jack board cable)	924527-001
(9)	Power button board cable (includes double-sided adhesive)	924511-001
(10)	Power button board (does not include power button board cable)	924526-001
(11)	Speakers (include cables and 4 rubber isolators)	924538-001
(12)	System board (includes processor and replacement thermal material):	
	For use only on computer models with model number 15-br1xx:	
	Equipped with an Intel Core i7-8550U 1.80-GHz (SC turbo up to 4.00-GHz) quad core processor (8.0-GB L3 cache, 2400-MHz FSB, 15-W), an AMD Radeon 530 R17M-M1-70 (Meso Pro) with up to 4096-MB of discrete video memory (512-MB×16 DDR3×4 pieces), and the Windows 10 operating system	936031-601
	Equipped with an Intel Core i7-8550U 1.80-GHz (SC turbo up to 4.00-GHz) quad core processor (8.0-GB L3 cache, 2400-MHz FSB, 15-W), an AMD Radeon 530 R17M-M1-70 (Meso Pro) with up to 4096-MB of discrete video memory (512-MB×16 DDR3×4 pieces), and a non-Windows operating system	936031-001
	For use on all computer models:	
	Equipped with an Intel Core i7-7500U 2.70-GHz (SC turbo up to 3.56-GHz) dual core processor (4.0-GB L3 cache, 2133-MHz FSB, 15-W), an AMD Radeon 530 R17M-M1-70 (Meso Pro) with up to 4096-MB of discrete video memory (512-MB×16 DDR3×4 pieces), and the Windows 10 operating system	924080-601
	Equipped with an Intel Core i7-7500U 2.70-GHz (SC turbo up to 3.56-GHz) dual core processor (4.0-GB L3 cache, 2133-MHz FSB, 15-W), an AMD Radeon 530 R17M-M1-70 (Meso Pro) with up to 4096-MB of discrete video memory (512-MB×16 DDR3×4 pieces), and a non-Windows operating system	924080-001
	Equipped with an Intel Core i5-7200U 2.56-GHz (SC turbo up to 3.10-GHz) dual core processor (3.0-GB L3 cache, 2133-MHz FSB, 15-W), an AMD Radeon 530 R17M-M1-70 (Meso Pro) with up to 2048-MB of discrete video memory (256-MB×16 DDR3×4 pieces), and the Windows 10 operating system	924081-601
	Equipped with an Intel Core i5-7200U 2.56-GHz (SC turbo up to 3.10-GHz) dual core processor (3.0-GB L3 cache, 2133-MHz FSB, 15-W), an AMD Radeon 530 R17M-M1-70 (Meso Pro) with up to 2048-MB of discrete video memory (256-MB×16 DDR3×4 pieces), and a non-Windows operating system	924081-001
	Equipped with an Intel Core i5-7200U 2.56-GHz (SC turbo up to 3.10-GHz) dual core processor (3.0-GB L3 cache, 2133-MHz FSB, 15-W), an Intel HD Graphics 620 subsystem with UMA video memory, and the Windows 10 operating system for use only computer models equipped with an infrared camera	924077-601

Item	Component	Spare part number
	Equipped with an Intel Core i5-7200U 2.56-GHz (SC turbo up to 3.10-GHz) dual core processor (3.0-GB L3 cache, 2133-MHz FSB, 15-W), an Intel HD Graphics 620 subsystem with UMA video memory, and a non-Windows operating system for use only computer models equipped with an infrared camera	924077-001
	Equipped with an Intel Core i3-7100U 2.40-GHz dual core processor (3.0-GB L3 cache, 2133-MHz FSB, 15-W), an AMD Radeon 530 R17M-M1-70 (Meso Pro) with up to 2048-MB of discrete video memory (256-MB×16 DDR3×4 pieces), and the Windows 10 operating system	924082-601
	Equipped with an Intel Core i3-7100U 2.40-GHz dual core processor (3.0-GB L3 cache, 2133-MHz FSB, 15-W), an AMD Radeon 530 R17M-M1-70 (Meso Pro) with up to 2048-MB of discrete video memory (256-MB×16 DDR3×4 pieces), and a non-Windows operating system	924082-001
	Equipped with an Intel Core i3-7100U 2.40-GHz dual core processor (3.0-GB L3 cache, 2133-MHz FSB, 15-W), an Intel HD Graphics 620 subsystem with UMA video memory, and the Windows 10 operating system	924078-601
	Equipped with an Intel Core i3-7100U 2.40-GHz dual core processor (3.0-GB L3 cache, 2133-MHz FSB, 15-W), an Intel HD Graphics 620 subsystem with UMA video memory, and a non-Windows operating system	924078-001
	Equipped with an Intel Pentium 4415U 2.36-GHz dual core processor (2.0-GB L3 cache, 2133-MHz FSB, 15-W), an Intel HD Graphics subsystem with UMA video memory, and the Windows 10 operating system	924079-601
	Equipped with an Intel Pentium 4415U 2.36-GHz dual core processor (2.0-GB L3 cache, 2133-MHz FSB, 15-W), an Intel HD Graphics subsystem with UMA video memory, and a non-Windows operating system	924079-001
(13)	Fan/heat sink assembly (includes fan cable and replacement thermal material):	
	For use only on computer models equipped with an Intel Core i7-8550U processor	934962-001
	For use only on computer models with model number 15-br0xx equipped with a graphics subsystem with discrete memory	924514-001
	For use only on computer models with model number 15-br0xx equipped with a graphics subsystem with UMA memory	924513-001
(14)	WLAN module:	
	Intel Dual Band Wireless-AC 7265 802.11 AC 2×2 WiFi + Bluetooth 4.2 Combo Adapter (non-vPro)	901229-855
	Intel Dual Band Wireless-AC 3168 802.11AC 1×1 WiFi + Bluetooth 4.2 Combo Adapter (non-vPro)	863934-855
(15)	Memory modules (2, does not include memory shield):	
	8-MB, DDR4-2400, 1.2-V	820570-005
	4-MB, DDR4-2400, 1.2-V	862397-855
	2-MB, DDR4-2133, 1.2-V	864271-855
	NOTE: The memory module shield is available using spare part number 925378-001.	
(16)	Solid-state drive:	
	For use only on computer models with model number 15-br1xx:	
	256-GB, M.2 SATA-3 solid-state drive with TLC	934960-001
	128-GB, M.2 SATA-3 solid-state drive with TLC	934959-001
	For use on all computer models:	

Item	Component	Spare part number
	512-GB, M.2 SATA-3 solid-state drive with TLC	924083-001
	512-GB, 2280, PCIe, NVMe solid-state drive	L01520-001
	256-GB, 2280, PCIe, NVMe solid-state drive	L01521-001
	256-GB, M.2 SATA-3 solid-state drive	924085-001
	128-GB, M.2 SATA-3 solid-state drive	924084-001
	Solid-State Drive Rubber Kit (not illustrated)	925033-001
	Solid-state drive counterbalance weight (not illustrated)	934083-001
(17)	Power connector cable (does not include power connector cable bracket)	808155-024
	NOTE: The power connector cable bracket is available using spare part number 924516-001.	
	Power connector cable bracket (not illustrated)	924516-001
(18)	Base enclosure:	
	In natural silver finish	924505-001
	In silk gold finish	924506-001
	Rubber Foot Kit (not illustrated, includes rear rubber feet):	
	In natural silver finish	924886-001
	In silk gold finish	924887-001
	Screw Mylar Kit (not illustrated, includes Mylar screw cover):	
	In natural silver finish	924534-001
	In silk gold finish	924535-001

Display assembly subcomponents

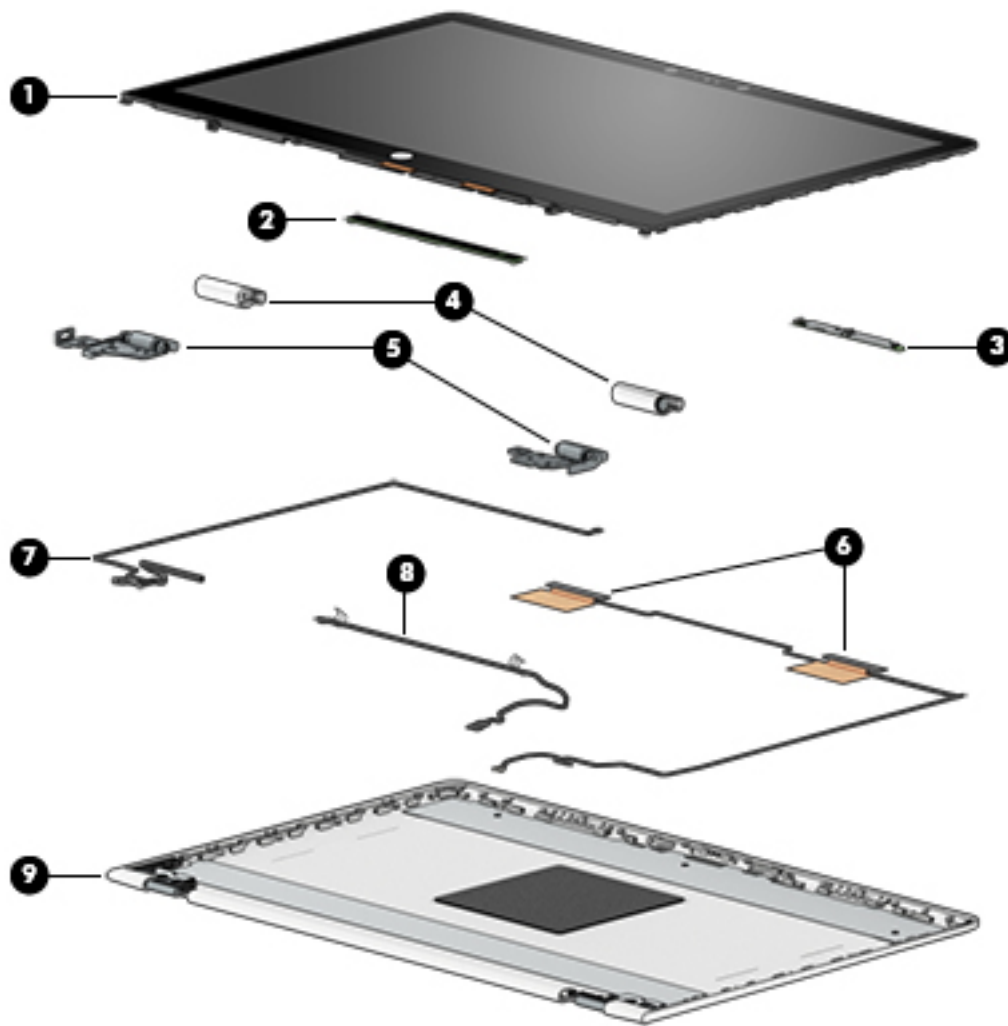

Item	Component	Spare part number
(1)	Display Panel Kit (includes display panel cable):	
	15.6-in, FHD, WLED, BrightView, TouchScreen equipped with an FHD infrared camera	924530-001
	15.6-in, FHD, WLED, BrightView, TouchScreen equipped with an HD non-infrared camera	925711-001
	15.6-in, HD, WLED, AntiGlare, TouchScreen equipped with an HD non-infrared camera	924531-001
(2)	TouchScreen board (includes G-sensor board and double-sided adhesive)	929145-001
(3)	Webcam/microphone module (includes Mylar and double-sided adhesive):	
	FHD infrared webcam/microphone module	924477-001
	HD non-infrared webcam/microphone module	924478-001
(4)	Hinge cover:	
	Left hinge cap for use only on computer models equipped with an FHD display panel	926720-001
	Right hinge cap for use only on computer models equipped with an FHD display panel	926721-001

Item	Component	Spare part number
	Left hinge cap for use only on computer models equipped with an HD display panel	926718-001
	Right hinge cap for use only on computer models equipped with an HD display panel	926719-001
(5)	Hinge (2, includes left and right display hinges):	
	For use only on computer models equipped with an FHD display panel	924519-001
	For use only on computer models equipped with an HD display panel	924518-001
(6)	WLAN antenna (includes left and right WLAN cables and transceivers)	924476-001
(7)	Display panel cable (includes the webcam/microphone module cable)	
	For use only on computer models equipped with an FHD infrared webcam/ microphone module	924507-001
	For use only on computer models equipped with an HD non-infrared webcam/ microphone module	924508-001
(8)	TouchScreen board cable (includes the G-sensor board cable)	924512-001
(9)	Display enclosure (includes rubber padding and shielding):	
	For use only on computer models equipped with an FHD display assembly:	
	In natural silver finish	924501-001
	In silk gold finish	924502-001
	For use only on computer models equipped with an HD display assembly:	
	In natural silver finish	924499-001
	In silk gold finish	924500-001

Miscellaneous parts

Component	Spare part number
AC adapter:	
For use only on computer models with model number 15-br1xx:	
90-W AC adapter (PFC, S-3P, 4.5-mm)	710413-001
For use on all computer models:	
65-W HP Smart AC adapter (non-PFC, EM, RC, 4.5-mm)	913691-850
65-W AC adapter (non-PFC, S-3P, 4.5-mm)	710412-001
45-W HP Smart AC adapter (non-PFC, RC, 4.5-mm, non-slim)	741553-850
HP HDMI-to-VGA adapter	701943-001
HP external DVD±RW DL SuperMulti Drive	747080-001
HP USB-to-Gigabit RJ45 adapter	829941-001
HP USB-C-to-USB-A dongle	833960-001
Power cord (C5 connector, 1.00-m):	
For use in Argentina	920688-003
For use in Australia	920688-011
For use in Denmark	920688-007
For use in Europe	920688-005
For use in India	920688-016
For use in Israel	920688-008
For use in Italy	920688-002
For use in North America	920688-001
For use in the People's Republic of China	920688-014
For use in South Africa	920688-010
For use in Switzerland	920688-009
For use in the United Kingdom and Singapore	920688-006
Rubber Foot Kit (includes bottom cover rear feet):	
In natural silver finish	924886-001
In silk gold finish	924887-001
Screw Kit	924537-001
Screw Mylar Kit (includes Mylar screw cover):	
In natural silver finish	924534-001
In silk gold finish	924535-001
Stylus (active pen in Pike silver finish)	910942-001

4 Removal and replacement preliminary requirements

Tools required

You will need the following tools to complete the removal and replacement procedures:

- Flat-bladed screw driver
- Magnetic screw driver
- Phillips P0 screw driver

Service considerations

The following sections include some of the considerations that you must keep in mind during disassembly and assembly procedures.

 **NOTE:** As you remove each subassembly from the computer, place the subassembly (and all accompanying screws) away from the work area to prevent damage.

Plastic parts

 **CAUTION:** Using excessive force during disassembly and reassembly can damage plastic parts. Use care when handling the plastic parts. Apply pressure only at the points designated in the maintenance instructions.

Cables and connectors

 **CAUTION:** When servicing the computer, be sure that cables are placed in their proper locations during the reassembly process. Improper cable placement can damage the computer.

Cables must be handled with extreme care to avoid damage. Apply only the tension required to unseat or seat the cables during removal and insertion. Handle cables by the connector whenever possible. In all cases, avoid bending, twisting, or tearing cables. Be sure that cables are routed in such a way that they cannot be caught or snagged by parts being removed or replaced. Handle flex cables with extreme care; these cables tear easily.

Drive handling

⚠ CAUTION: Drives are fragile components that must be handled with care. To prevent damage to the computer, damage to a drive, or loss of information, observe these precautions:

Before removing or inserting a drive, shut down the computer. If you are unsure whether the computer is off or in Hibernation, turn the computer on, and then shut it down through the operating system.

Before handling a drive, be sure that you are discharged of static electricity. While handling a drive, avoid touching the connector.

Before removing a diskette drive or optical drive, be sure that a diskette or disc is not in the drive and be sure that the optical drive tray is closed.

Handle drives on surfaces covered with at least one inch of shock-proof foam.

Avoid dropping drives from any height onto any surface.

After removing drive, place it in a static-proof bag.

Avoid exposing a drive to products that have magnetic fields, such as monitors or speakers.

Avoid exposing a drive to temperature extremes or liquids.

If a drive must be mailed, place the drive in a bubble pack mailer or other suitable form of protective packaging and label the package "FRAGILE."

Grounding guidelines

Electrostatic discharge damage

Electronic components are sensitive to electrostatic discharge (ESD). Circuitry design and structure determine the degree of sensitivity. Networks built into many integrated circuits provide some protection, but in many cases, ESD contains enough power to alter device parameters or melt silicon junctions.

A discharge of static electricity from a finger or other conductor can destroy static-sensitive devices or microcircuitry. Even if the spark is neither felt nor heard, damage may have occurred.

An electronic device exposed to ESD may not be affected at all and can work perfectly throughout a normal cycle. Or the device may function normally for a while, then degrade in the internal layers, reducing its life expectancy.

CAUTION: To prevent damage to the computer when you are removing or installing internal components, observe these precautions:

Keep components in their electrostatic-safe containers until you are ready to install them.

Before touching an electronic component, discharge static electricity by using the guidelines described in this section.

Avoid touching pins, leads, and circuitry. Handle electronic components as little as possible.

If you remove a component, place it in an electrostatic-safe container.

The following table shows how humidity affects the electrostatic voltage levels generated by different activities.

CAUTION: A product can be degraded by as little as 700 V.

Typical electrostatic voltage levels			
Event	Relative humidity		
	10%	40%	55%
Walking across carpet	35,000 V	15,000 V	7,500 V
Walking across vinyl floor	12,000 V	5,000 V	3,000 V
Motions of bench worker	6,000 V	800 V	400 V
Removing DIPS from plastic tube	2,000 V	700 V	400 V
Removing DIPS from vinyl tray	11,500 V	4,000 V	2,000 V
Removing DIPS from Styrofoam	14,500 V	5,000 V	3,500 V
Removing bubble pack from PCB	26,500 V	20,000 V	7,000 V
Packing PCBs in foam-lined box	21,000 V	11,000 V	5,000 V

Packaging and transporting guidelines

Follow these grounding guidelines when packaging and transporting equipment:

- To avoid hand contact, transport products in static-safe tubes, bags, or boxes.
- Protect ESD-sensitive parts and assemblies with conductive or approved containers or packaging.
- Keep ESD-sensitive parts in their containers until the parts arrive at static-free workstations.
- Place items on a grounded surface before removing items from their containers.
- Always be properly grounded when touching a component or assembly.
- Store reusable ESD-sensitive parts from assemblies in protective packaging or nonconductive foam.
- Use transporters and conveyors made of antistatic belts and roller bushings. Be sure that mechanized equipment used for moving materials is wired to ground and that proper materials are selected to avoid static charging. When grounding is not possible, use an ionizer to dissipate electric charges.

Workstation guidelines

Follow these grounding workstation guidelines:

- Cover the workstation with approved static-shielding material.
- Use a wrist strap connected to a properly grounded work surface and use properly grounded tools and equipment.
- Use conductive field service tools, such as cutters, screw drivers, and vacuums.
- When fixtures must directly contact dissipative surfaces, use fixtures made only of static-safe materials.
- Keep the work area free of nonconductive materials, such as ordinary plastic assembly aids and Styrofoam.
- Handle ESD-sensitive components, parts, and assemblies by the case or PCM laminate. Handle these items only at static-free workstations.
- Avoid contact with pins, leads, or circuitry.
- Turn off power and input signals before inserting or removing connectors or test equipment.

Equipment guidelines

Grounding equipment must include either a wrist strap or a foot strap at a grounded workstation.

- When seated, wear a wrist strap connected to a grounded system. Wrist straps are flexible straps with a minimum of one megohm $\pm 10\%$ resistance in the ground cords. To provide proper ground, wear a strap snugly against the skin at all times. On grounded mats with banana-plug connectors, use alligator clips to connect a wrist strap.
- When standing, use foot straps and a grounded floor mat. Foot straps (heel, toe, or boot straps) can be used at standing workstations and are compatible with most types of shoes or boots. On conductive floors or dissipative floor mats, use foot straps on both feet with a minimum of one megohm resistance between the operator and ground. To be effective, the conductive must be worn in contact with the skin.

The following grounding equipment is recommended to prevent electrostatic damage:

- Antistatic tape
- Antistatic smocks, aprons, and sleeve protectors
- Conductive bins and other assembly or soldering aids
- Nonconductive foam
- Conductive computerop workstations with ground cords of one megohm resistance
- Static-dissipative tables or floor mats with hard ties to the ground
- Field service kits
- Static awareness labels
- Material-handling packages
- Nonconductive plastic bags, tubes, or boxes
- Metal tote boxes
- Electrostatic voltage levels and protective materials

The following table lists the shielding protection provided by antistatic bags and floor mats.

Material	Use	Voltage protection level
Antistatic plastics	Bags	1,500 V
Carbon-loaded plastic	Floor mats	7,500 V
Metallized laminate	Floor mats	5,000 V

5 Removal and replacement procedures

This chapter provides removal and replacement procedures for Authorized Service Provider only parts.

CAUTION: Components described in this chapter should only be accessed by an authorized service provider. Accessing these parts can damage the computer or void the warranty.

CAUTION: This computer does not have user-replaceable parts. Only HP authorized service providers should perform the removal and replacement procedures described here. Accessing the internal part could damage the computer or void the warranty.

Component replacement procedures

NOTE: Details about your computer, including model, serial number, product key, and length of warranty, are on the service tag at the bottom of your computer. See [Labels on page 9](#) for details.

NOTE: HP continually improves and changes product parts. For complete and current information on supported parts for your computer, go to <http://partsurfer.hp.com>, select your country or region, and then follow the on-screen instructions.

There are as many as 58 screws that must be removed, replaced, and/or loosened when servicing Authorized Service Provider only parts. Make special note of each screw size and location during removal and replacement.

Keyboard/top cover

For use in country/region	Spare part number	For use in country/region	Spare part number
In ash silver finish with backlight for use only on computer models equipped with a graphics subsystem with discrete memory (includes backlight cable and keyboard cable):			
For use in Canada	924525-DB1	For use in the United States	924525-001
In ash silver finish with backlight for use only on computer models equipped with a graphics subsystem with UMA memory (includes backlight cable and keyboard cable):			
For use in Canada	924524-DB1	For use in the United States	924525-001
In ash silver finish for use only on computer models equipped with a graphics subsystem with discrete memory (includes keyboard cable):			
For use in Belgium	924523-A41	For use in Latin America	924523-161
For use in Bulgaria	924523-261	For use in the Netherlands	924523-B31
For use in Canada	924523-DB1	For use in Portugal	924523-131
For use in the Czech Republic and Slovakia	924523-FL1	For use in Romania	924523-271
For use in Denmark, Finland, and Norway	924523-DH1	For use in Russia	924523-251
For use in France	924523-051	For use in Saudi Arabia	924523-171
For use in Germany	924523-041	For use in Slovenia	924523-BA1

For use in country/region	Spare part number	For use in country/region	Spare part number
For use in Greece	924523-151	For use in Spain	924523-071
For use in Hungary	924523-211	For use in Switzerland	924523-BG1
For use in India	924523-002	For use in Turkey	924523-141
For use in Israel	924523-BB1	For use in the United Kingdom	924523-031
For use in Italy	924523-061	For use in the United States	924523-001
In ash silver finish for use only on computer models equipped with a graphics subsystem with UMA memory (includes keyboard cable):			
For use in Belgium	924522-A41	For use in Latin America	924522-161
For use in Bulgaria	924522-261	For use in the Netherlands	924522-B31
For use in Canada	924522-DB1	For use in Portugal	924522-131
For use in the Czech Republic and Slovakia	924522-FL1	For use in Romania	924522-271
For use in Denmark, Finland, and Norway	924522-DH1	For use in Russia	924522-251
For use in France	924522-051	For use in Saudi Arabia	924522-171
For use in Germany	924522-041	For use in Slovenia	924522-BA1
For use in Greece	924522-151	For use in Spain	924522-071
For use in Hungary	924522-211	For use in Switzerland	924522-BG1
For use in India	924522-002	For use in Turkey	924522-141
For use in Israel	924522-BB1	For use in the United Kingdom	924522-031
For use in Italy	924522-061	For use in the United States	924522-001

Before disassembling the computer, follow these steps:

1. Shut down the computer. If you are unsure whether the computer is off or in Hibernation, turn the computer on, and then shut it down through the operating system.
2. Disconnect all external devices connected to the computer.
3. Disconnect the power from the computer by first unplugging the power cord from the AC outlet, and then unplugging the AC adapter from the computer.

Remove the keyboard/top cover:

1. Turn the computer upside down on a flat surface.
2. Position the computer with the front toward you.
3. Remove the rear rubber feet **(1)**.

The rear rubber feet are included in the Rubber Foot Kits, spare part numbers 924886-001 (in natural silver finish) and 924887-001 (in silk gold finish).

4. Remove the Mylar screw cover **(2)**.

The Mylar screw cover is included in the Screw Mylar Kit, spare part numbers 924834-001 (in natural silver finish) and 924835-001 (in silk gold finish).

5. Remove the four Phillips PM2.0×4.9 screws **(3)** and the two Phillips PM2.5×7.6 screws **(4)** that secure the keyboard/top cover to the base enclosure.

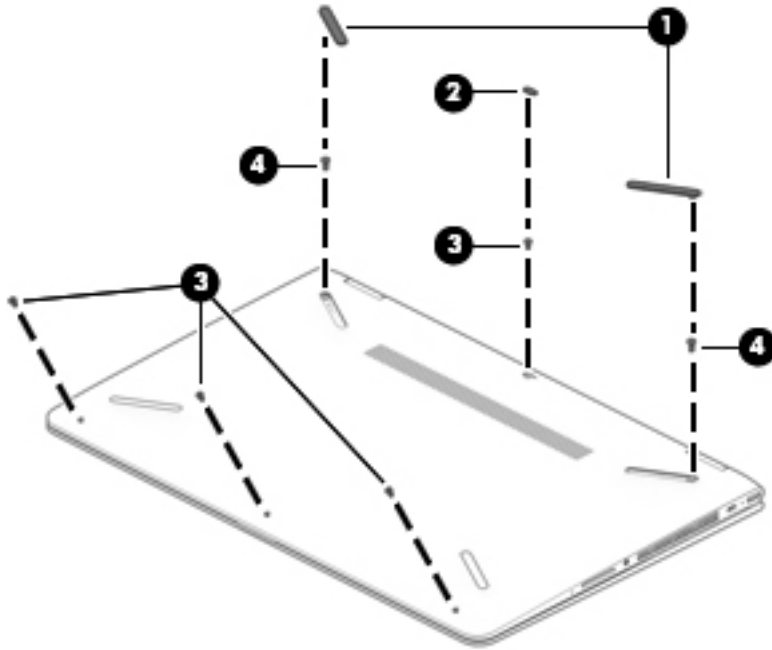

6. Turn the computer right side up.
7. Open the computer and position it on its left side with the bottom toward you.
8. Insert a keyboard release tool **(1)** into the empty screw holes under the rubber feet.
9. Press on the keyboard release tool until the keyboard/top cover **(2)** releases from the computer.

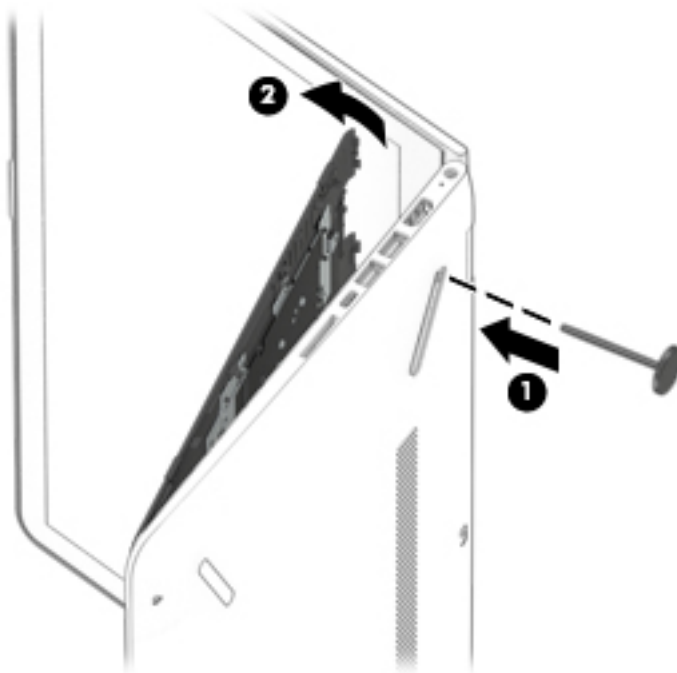

10. Lift the front edge of the keyboard/top cover (1) until the keyboard cable, backlight cable, and TouchPad cable connectors are accessible.
11. Release the zero insertion force (ZIF) connector (2) to which keyboard cable is connected, and then disconnect the keyboard cable from the system board.
12. Release the ZIF connector (3) to which backlight cable is connected, and then disconnect the backlight cable from the system board.
13. Release the ZIF connector (4) to which TouchPad cable is connected, and then disconnect the TouchPad cable from the system board.

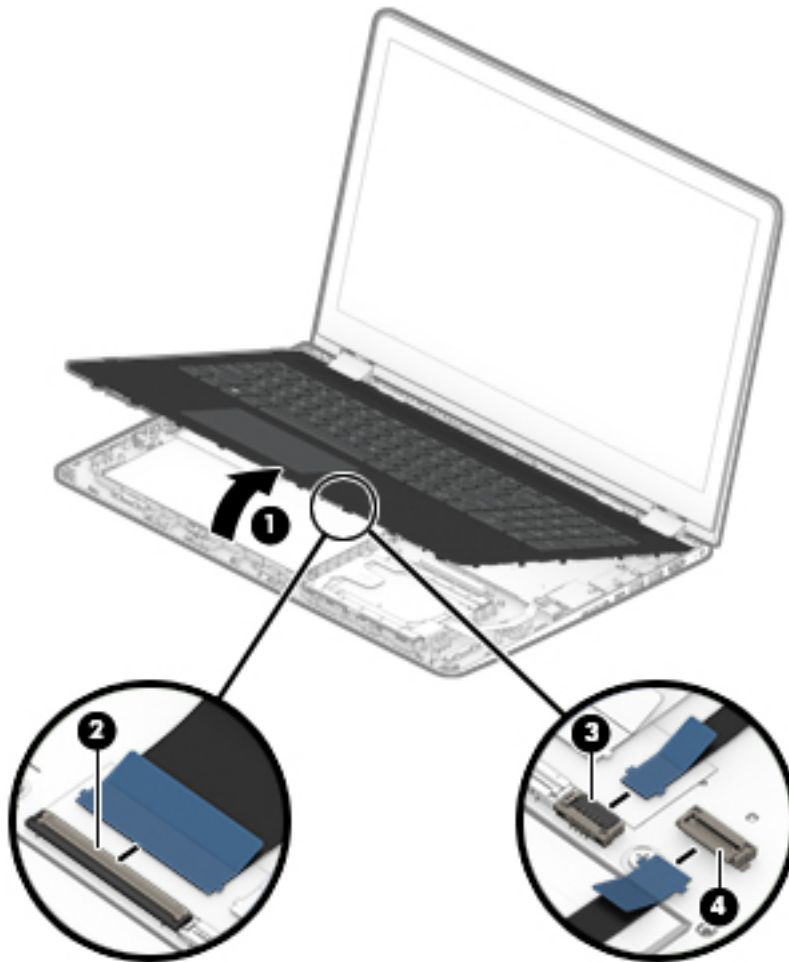

14. Remove the keyboard/top cover.

Reverse this procedure to install the keyboard/top cover.

TouchPad cable



NOTE: The TouchPad cable is available using spare part number 924509-001.

Before removing the TouchPad cable, follow these steps:

1. Shut down the computer. If you are unsure whether the computer is off or in Hibernation, turn the computer on, and then shut it down through the operating system.
2. Disconnect all external devices connected to the computer.
3. Disconnect the power from the computer by first unplugging the power cord from the AC outlet, and then unplugging the AC adapter from the computer.
4. Remove the keyboard/top cover (see [Keyboard/top cover on page 24](#)).

Remove the TouchPad cable:

1. Release the ZIF connector **(1)** to which TouchPad cable is connected, and then disconnect the TouchPad cable **(2)** from the TouchPad.
2. Detach the TouchPad cable **(3)** from the keyboard/top cover. (The TouchPad cable is attached to the keyboard/top cover with double-sided adhesive.)

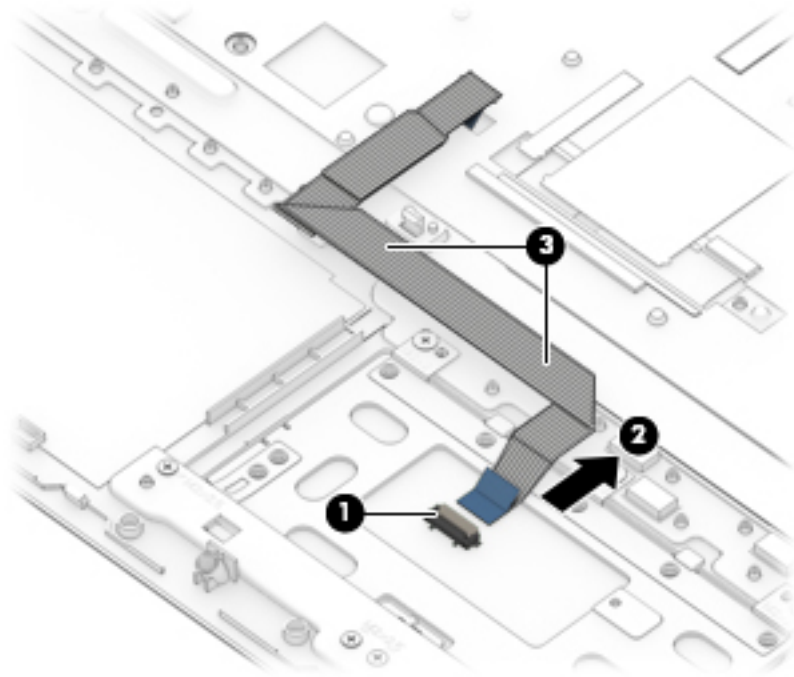

3. Remove the TouchPad cable.

Reverse this procedure to install the TouchPad cable.

TouchPad

 **NOTE:** The TouchPad spare part kit does not include the TouchPad bracket or TouchPad cable. The TouchPad bracket is available using spare part number 924517-001. The TouchPad cable is available using spare part number 924509-001.

Description	Spare part number
TouchPad	924529-001

Before removing the TouchPad, follow these steps:

1. Shut down the computer. If you are unsure whether the computer is off or in Hibernation, turn the computer on, and then shut it down through the operating system.
2. Disconnect all external devices connected to the computer.
3. Disconnect the power from the computer by first unplugging the power cord from the AC outlet, and then unplugging the AC adapter from the computer.
4. Remove the keyboard/top cover (see [Keyboard/top cover on page 24](#)).

Remove the TouchPad:

1. Turn the keyboard/top cover upside down with the front toward you.
2. Remove the four Phillips PM2.0×2.8 screws **(1)** that secure the TouchPad bracket to the keyboard/top cover.
3. Remove the TouchPad bracket **(2)**.

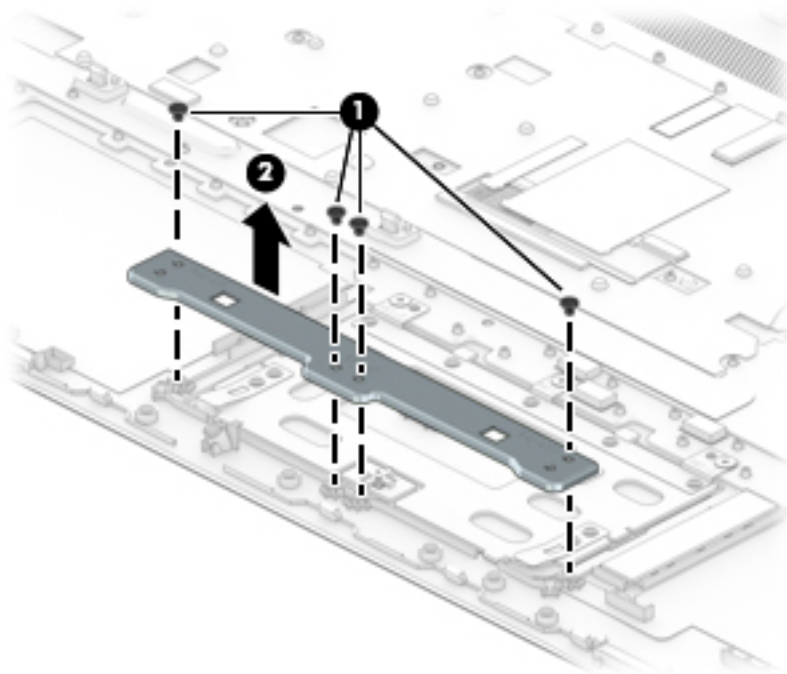

4. Remove the three Phillips PM2.0×2.3 broad head screws **(1)** that secure the TouchPad to the keyboard/top cover.

5. Remove the TouchPad **(2)**.

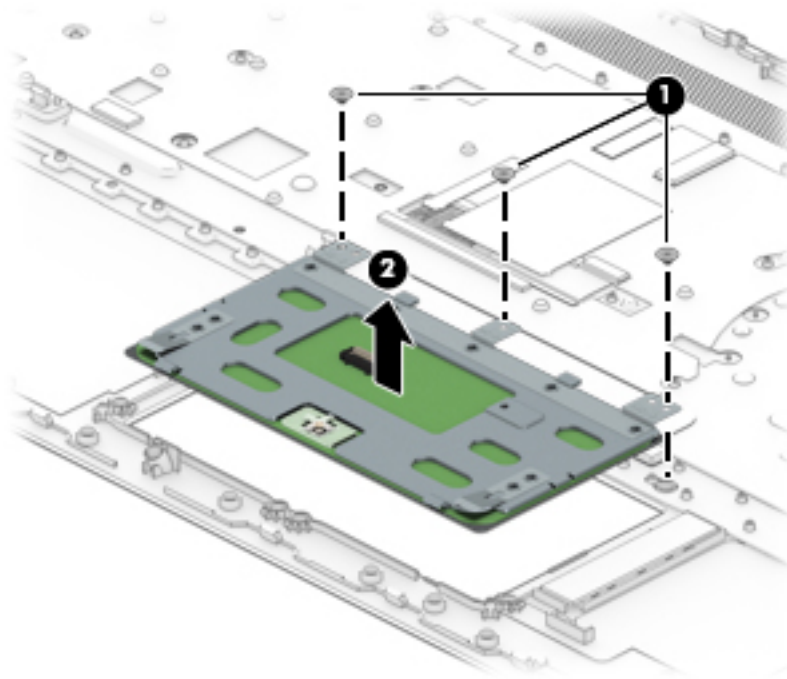

Reverse this procedure to install the TouchPad.

Battery

Description	Spare part number
3-cell, 48-WHr, 4.2-AHr, Li-ion battery	916812-855

Before removing the battery, follow these steps:

1. Shut down the computer. If you are unsure whether the computer is off or in Hibernation, turn the computer on, and then shut it down through the operating system.
2. Disconnect all external devices connected to the computer.
3. Disconnect the power from the computer by first unplugging the power cord from the AC outlet, and then unplugging the AC adapter from the computer.
4. Remove the keyboard/top cover (see [Keyboard/top cover on page 24](#)).

Remove the battery:

1. Release the ZIF connector **(1)** to which audio jack board cable is connected, and then disconnect the audio jack board cable **(2)** from the system board.
2. Detach the audio jack board cable **(2)** from the battery. (The audio jack board cable is attached to the battery with double-sided adhesive.)
3. Remove the seven Phillips PM2.0×4.6 screws **(3)** that secure the battery to the computer.

4. Remove the battery (4).

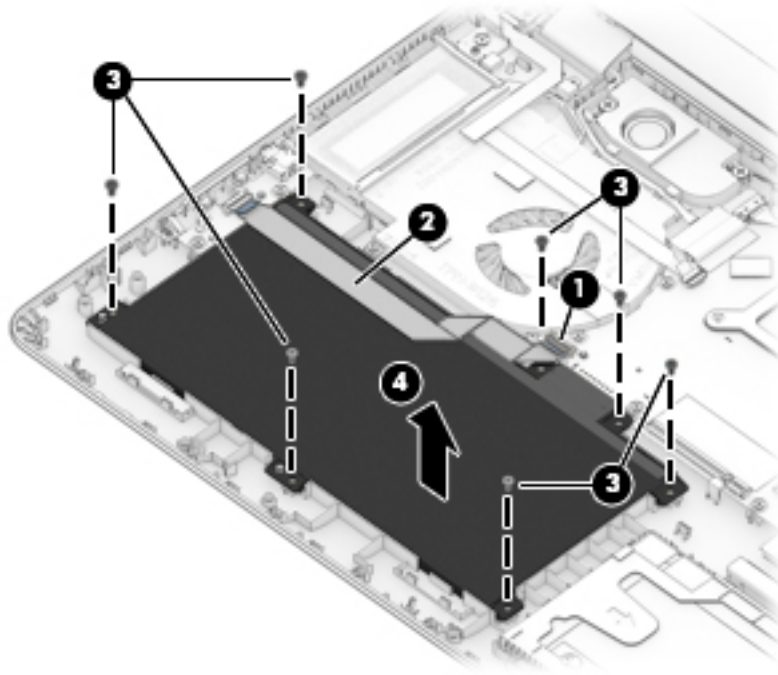

Reverse this procedure to install the battery.

Hard drive

 **NOTE:** The hard drive spare part kit does not include the hard drive rubber sleeve. The hard drive rubber sleeve is available using spare part number 924283-001.

Description	Spare part number
1-TB, 5400-rpm, SATA, 8-GB hybrid hard drive	924036-856
1-TB, 5400-rpm, SATA hard drive	762888-859
500-GB, 5400-rpm, SATA, 8-GB hybrid hard drive	731863-858
500-GB, 5400-rpm, SATA hard drive	683839-859

Before removing the hard drive, follow these steps:

1. Shut down the computer. If you are unsure whether the computer is off or in Hibernation, turn the computer on, and then shut it down through the operating system.
2. Disconnect all external devices connected to the computer.
3. Disconnect the power from the computer by first unplugging the power cord from the AC outlet, and then unplugging the AC adapter from the computer.
4. Remove the keyboard/top cover (see [Keyboard/top cover on page 24](#)).
5. Remove the battery (see [Battery on page 30](#)).

Remove the hard drive:

1. Release the ZIF connector **(1)** to which the hard drive cable is connected, and then disconnect the hard drive cable from the system board.
2. Detach the hard drive cable **(2)** from the base enclosure. (The hard drive cable is attached to the base enclosure with double-sided adhesive.)
3. Use the tab **(3)** on the hard drive rubber sleeve to remove the hard drive.

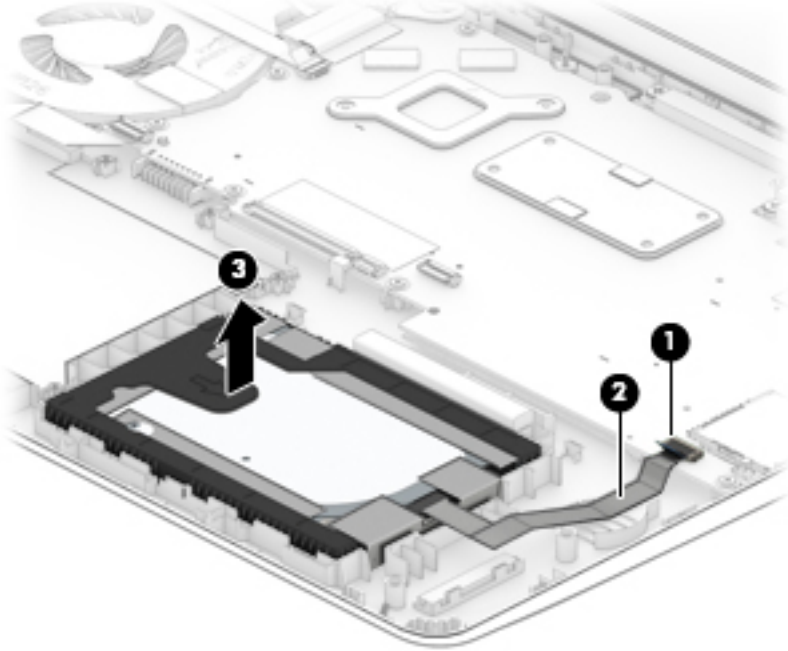

4. If it is necessary to remove the hard drive from the rubber sleeve, spread the open end of the rubber sleeve **(1)**, and then remove the hard drive **(2)**.

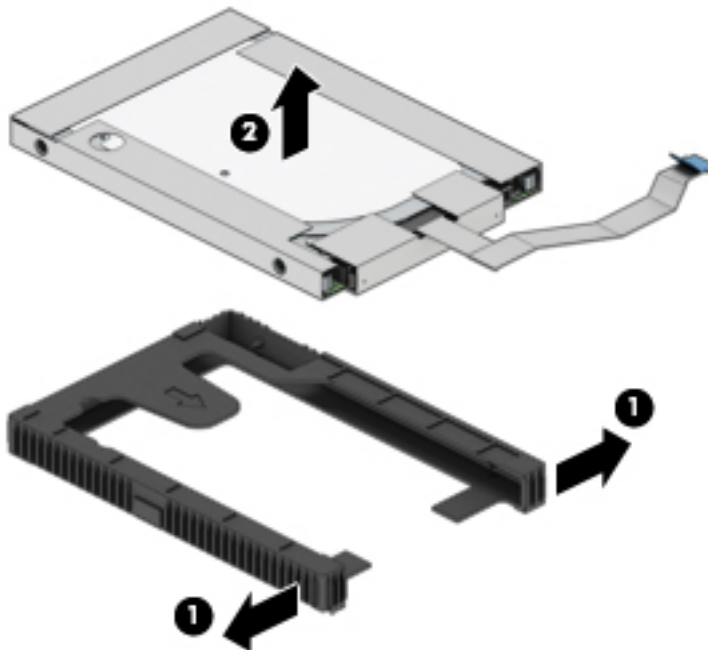

Reverse this procedure to reassemble and install the hard drive.

Audio jack board cable

 **NOTE:** The audio jack board cable is available using spare part number 924510-001.

Before removing the audio jack board cable, follow these steps:

1. Shut down the computer. If you are unsure whether the computer is off or in Hibernation, turn the computer on, and then shut it down through the operating system.
2. Disconnect all external devices connected to the computer.
3. Disconnect the power from the computer by first unplugging the power cord from the AC outlet, and then unplugging the AC adapter from the computer.
4. Remove the keyboard/top cover (see [Keyboard/top cover on page 24](#)).
5. Remove the battery (see [Battery on page 30](#)).

Remove the audio jack board cable:

1. Release the ZIF connector **(1)** to which audio jack board cable is connected, and then disconnect the audio jack board cable **(2)** from the audio jack board.

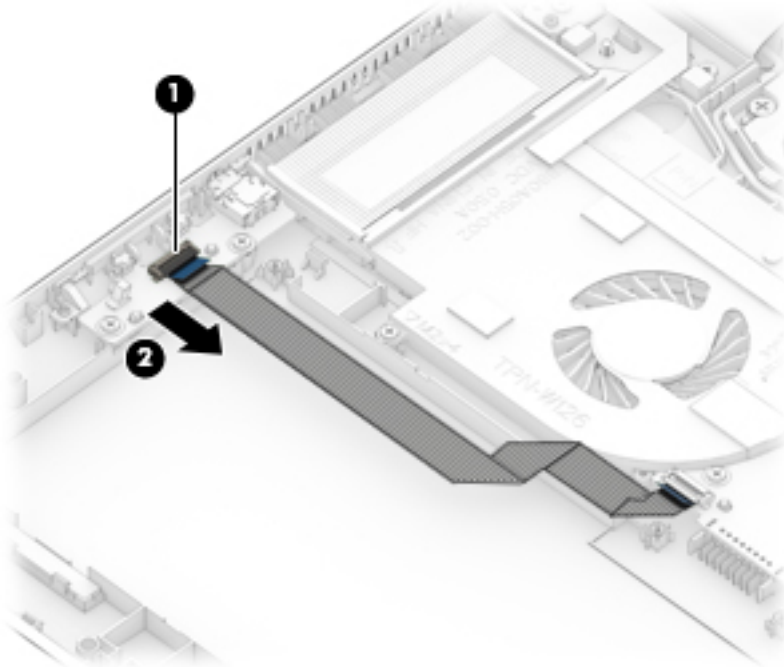

2. Remove the audio jack board cable.

Reverse this procedure to install the audio jack board cable.

Audio jack board

 **NOTE:** The audio jack board spare part kit does not include the audio jack board cable. The audio jack board cable is available using spare part number 924278-001.

Description	Spare part number
Audio jack board (includes audio jack, volume control actuators, and hard drive activity light; does not include audio jack board cable)	924527-001

Before removing the audio jack board, follow these steps:

1. Shut down the computer. If you are unsure whether the computer is off or in Hibernation, turn the computer on, and then shut it down through the operating system.
2. Disconnect all external devices connected to the computer.
3. Disconnect the power from the computer by first unplugging the power cord from the AC outlet, and then unplugging the AC adapter from the computer.
4. Remove the keyboard/top cover (see [Keyboard/top cover on page 24](#)).
5. Remove the battery (see [Battery on page 30](#)).

Remove the audio jack board:

1. Remove the two Phillips PM2.0×4.6 screws **(1)** that secure the audio jack board to the base enclosure.
2. Remove the audio jack board **(2)**.

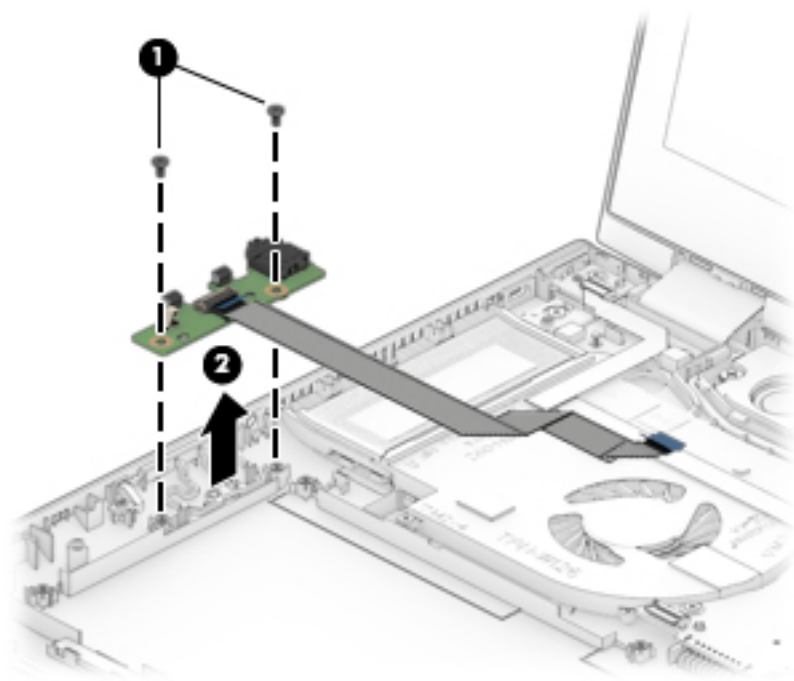

Reverse this procedure to install the audio jack board.

Power button board cable

 **NOTE:** The power button board cable is available using spare part number 924511-001.

Before removing the audio jack board cable, follow these steps:

1. Shut down the computer. If you are unsure whether the computer is off or in Hibernation, turn the computer on, and then shut it down through the operating system.
2. Disconnect all external devices connected to the computer.
3. Disconnect the power from the computer by first unplugging the power cord from the AC outlet, and then unplugging the AC adapter from the computer.
4. Remove the keyboard/top cover (see [Keyboard/top cover on page 24](#)).
5. Remove the battery (see [Battery on page 30](#)).

Remove the power button board cable:

1. Release the ZIF connector **(1)** to which power button board cable is connected, and then disconnect the power button board cable from the system board.
2. Release the ZIF connector **(2)** to which power button board cable is connected, and then disconnect the power button board cable from the power button board.
3. Detach the power button board cable **(3)** from the fan. (The power button board cable is attached to the fan with double-sided adhesive.)

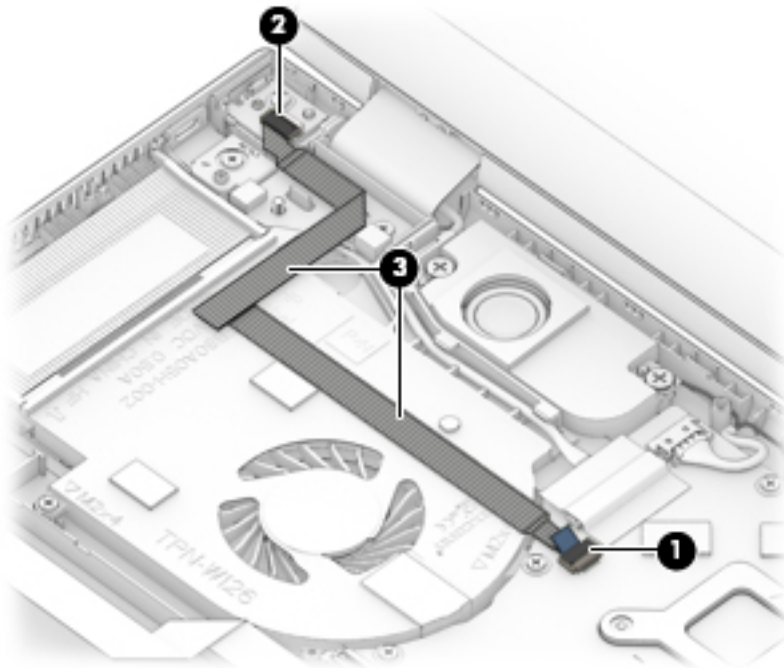

4. Remove the power button board cable.

Reverse this procedure to install the power button board cable.

Power button board



NOTE: The power button board spare part kit does not include the power button board cable. The power button board cable is available using spare part number 924511-001.

Description	Spare part number
Power button board	924526-001

Before removing the power button board, follow these steps:

1. Shut down the computer. If you are unsure whether the computer is off or in Hibernation, turn the computer on, and then shut it down through the operating system.
2. Disconnect all external devices connected to the computer.
3. Disconnect the power from the computer by first unplugging the power cord from the AC outlet, and then unplugging the AC adapter from the computer.
4. Remove the keyboard/top cover (see [Keyboard/top cover on page 24](#)).
5. Remove the battery (see [Battery on page 30](#)).

Remove the power button board:

1. Release the ZIF connector **(1)** to which power button board cable is connected, and then disconnect the power button board cable from the system board.
2. Detach the power button board cable **(2)** from the fan. (The power button board cable is attached to the fan with double-sided adhesive.)
3. Remove the Phillips PM2.0×4.6 screw **(3)** that secures the power button board to the base enclosure.
4. Remove the power button board **(4)**.

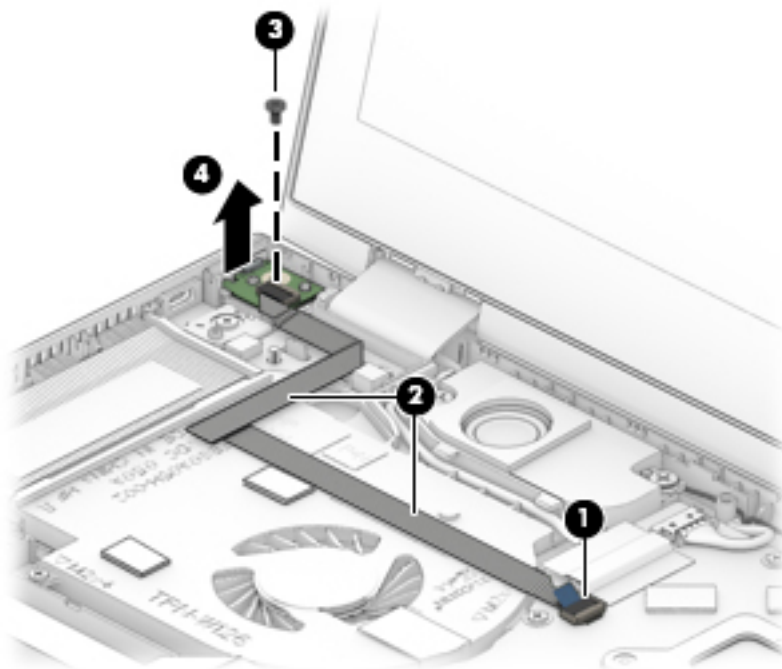

Reverse this procedure to install the power button board.

Speakers

Description	Spare part number
Speakers (includes cables and 3 rubber isolators)	924538-001

Before removing the speakers, follow these steps:

1. Turn off the computer. If you are unsure whether the computer is off or in Hibernation, turn the computer on, and then shut it down through the operating system.
2. Disconnect the power from the computer by first unplugging the power cord from the AC outlet, and then unplugging the AC adapter from the computer.
3. Disconnect all external devices from the computer.
4. Remove the keyboard/top cover (see [Keyboard/top cover on page 24](#)).
5. Remove the battery (see [Battery on page 30](#)).

Remove the speakers:

1. Disconnect the speaker cable **(1)** from the system board
2. Release the display speaker cable from the retention clips **(2)** built into the base enclosure.
3. Remove the four Phillips PM2.0×5.5 broad head shoulder screws **(3)** that secure the speakers to the base enclosure.
4. Remove the speakers **(4)**.

 **IMPORTANT:** When removing the speakers, make note of the location of the four rubber isolators **(5)**. Failure to properly install or damage to these isolators can result in degraded speaker performance.

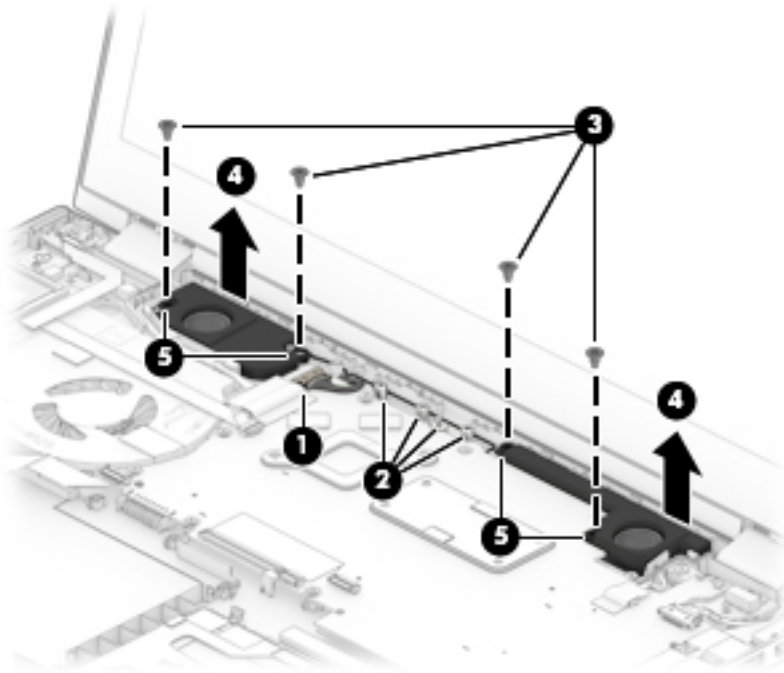

Reverse this procedure to install the speakers.

System board



NOTE: All system board spare part kits include a processor and replacement thermal material.

Description	Spare part number
For use only on computer models with model number 15-br1xx:	
Equipped with an Intel Core i7-8550U 1.80-GHz (SC turbo up to 4.00-GHz) quad core processor (8.0-GB L3 cache, 2400-MHz FSB, 15-W), an AMD Radeon 530 R17M-M1-70 (Meso Pro) with up to 4096-MB of discrete video memory (512-MB×16 DDR3×4 pieces), and the Windows 10 operating system	936031-601
Equipped with an Intel Core i7-8550U 1.80-GHz (SC turbo up to 4.00-GHz) quad core processor (8.0-GB L3 cache, 2400-MHz FSB, 15-W), an AMD Radeon 530 R17M-M1-70 (Meso Pro) with up to 4096-MB of discrete video memory (512-MB×16 DDR3×4 pieces), and a non-Windows operating system	936031-001
For use on all computer models:	
Equipped with an Intel Core i7-7500U 2.70-GHz (SC turbo up to 3.56-GHz) dual core processor (4.0-GB L3 cache, 2133-MHz FSB, 15-W), an AMD Radeon 530 R17M-M1-70 (Meso Pro) with up to 4096-MB of discrete video memory (512-MB×16 DDR3×4 pieces), and the Windows 10 operating system	924080-601
Equipped with an Intel Core i7-7500U 2.70-GHz (SC turbo up to 3.56-GHz) dual core processor (4.0-GB L3 cache, 2133-MHz FSB, 15-W), an AMD Radeon 530 R17M-M1-70 (Meso Pro) with up to 4096-MB of discrete video memory (512-MB×16 DDR3×4 pieces), and a non-Windows operating system	924080-001
Equipped with an Intel Core i5-7200U 2.56-GHz (SC turbo up to 3.10-GHz) dual core processor (3.0-GB L3 cache, 2133-MHz FSB, 15-W), an AMD Radeon 530 R17M-M1-70 (Meso Pro) with up to 2048-MB of discrete video memory (256-MB×16 DDR3×4 pieces), and the Windows 10 operating system	924081-601
Equipped with an Intel Core i5-7200U 2.56-GHz (SC turbo up to 3.10-GHz) dual core processor (3.0-GB L3 cache, 2133-MHz FSB, 15-W), an AMD Radeon 530 R17M-M1-70 (Meso Pro) with up to 2048-MB of discrete video memory (256-MB×16 DDR3×4 pieces), and a non-Windows operating system	924081-001
Equipped with an Intel Core i5-7200U 2.56-GHz (SC turbo up to 3.10-GHz) dual core processor (3.0-GB L3 cache, 2133-MHz FSB, 15-W), an Intel HD Graphics 620 subsystem with UMA video memory, and the Windows 10 operating system for use only computer models equipped with an infrared camera	924077-601
Equipped with an Intel Core i5-7200U 2.56-GHz (SC turbo up to 3.10-GHz) dual core processor (3.0-GB L3 cache, 2133-MHz FSB, 15-W), an Intel HD Graphics 620 subsystem with UMA video memory, and a non-Windows operating system for use only computer models equipped with an infrared camera	924077-001
Equipped with an Intel Core i3-7100U 2.40-GHz dual core processor (3.0-GB L3 cache, 2133-MHz FSB, 15-W), an AMD Radeon 530 R17M-M1-70 (Meso Pro) with up to 2048-MB of discrete video memory (256-MB×16 DDR3×4 pieces), and the Windows 10 operating system	924082-601
Equipped with an Intel Core i3-7100U 2.40-GHz dual core processor (3.0-GB L3 cache, 2133-MHz FSB, 15-W), an AMD Radeon 530 R17M-M1-70 (Meso Pro) with up to 2048-MB of discrete video memory (256-MB×16 DDR3×4 pieces), and a non-Windows operating system	924082-001
Equipped with an Intel Core i3-7100U 2.40-GHz dual core processor (3.0-GB L3 cache, 2133-MHz FSB, 15-W), an Intel HD Graphics 620 subsystem with UMA video memory, and the Windows 10 operating system	924078-601
Equipped with an Intel Core i3-7100U 2.40-GHz dual core processor (3.0-GB L3 cache, 2133-MHz FSB, 15-W), an Intel HD Graphics 620 subsystem with UMA video memory, and a non-Windows operating system	924078-001
Equipped with an Intel Pentium 4415U 2.36-GHz dual core processor (2.0-GB L3 cache, 2133-MHz FSB, 15-W), an Intel HD Graphics subsystem with UMA video memory, and the Windows 10 operating system	924079-601
Equipped with an Intel Pentium 4415U 2.36-GHz dual core processor (2.0-GB L3 cache, 2133-MHz FSB, 15-W), an Intel HD Graphics subsystem with UMA video memory, and a non-Windows operating system	924079-001

Before removing the system board, follow these steps:

1. Shut down the computer. If you are unsure whether the computer is off or in Hibernation, turn the computer on, and then shut it down through the operating system.
2. Disconnect all external devices connected to the computer.
3. Disconnect the power from the computer by first unplugging the power cord from the AC outlet, and then unplugging the AC adapter from the computer.
4. Remove the keyboard/top cover (see [Keyboard/top cover on page 24](#)).
5. Remove the battery (see [Battery on page 30](#)).
6. Remove the speakers (see [Speakers on page 37](#)).

When replacing the system board, be sure to remove the following components from the defective system board and install them on the replacement system board:

- WLAN module (see [WLAN module on page 42](#))
- Fan/heat sink assembly (see [Fan/heat sink assembly on page 43](#))
- Memory modules (see [Memory module on page 45](#))

Remove the system board:

1. Release the adhesive strip **(1)** that secures the display panel cable connector to the system board.
2. Release the ZIF connector **(2)** to which display panel cable is connected, and then disconnect the display panel cable from the system board.
3. Release the display panel cable from the retention clips **(3)** and routing channel built into the fan/heat sink assembly.
4. Release the ZIF connector **(4)** to which power button board cable is connected, and then disconnect the power button board cable from the system board.
5. Disconnect the wireless antenna cables **(5)** from the WLAN module.



NOTE: The #1/white WLAN antenna cable connects to the WLAN module "#1/Main" terminal. The #2/black WLAN antenna cable connects to the WLAN module "#2/Aux" terminal.

6. Release the adhesive strip **(6)** that secures the TouchScreen cable connector to the system board.
7. Release the ZIF connector **(7)** to which TouchScreen cable is connected, and then disconnect the TouchScreen cable from the system board.
8. Disconnect the power connector cable **(8)** from the system board.

9. Release the ZIF connector **(9)** to which hard drive cable is connected, and then disconnect the hard drive cable from the system board.

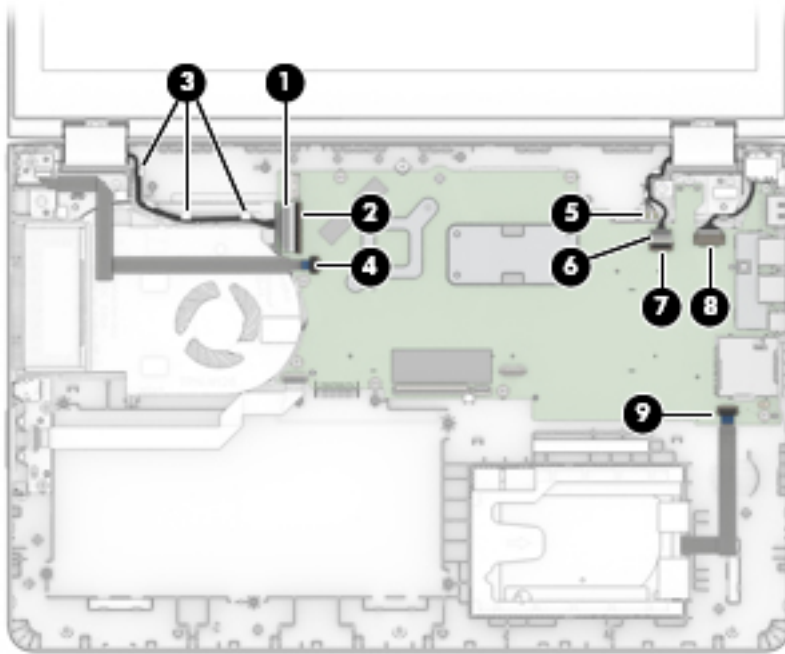

10. Remove the 10 Phillips PM2.0×4.6 screws **(1)** that secure the system board to the base enclosure.
11. Remove the Phillips PM2.0×3.7 screw **(2)** that secures the WLAN module to the base enclosure.

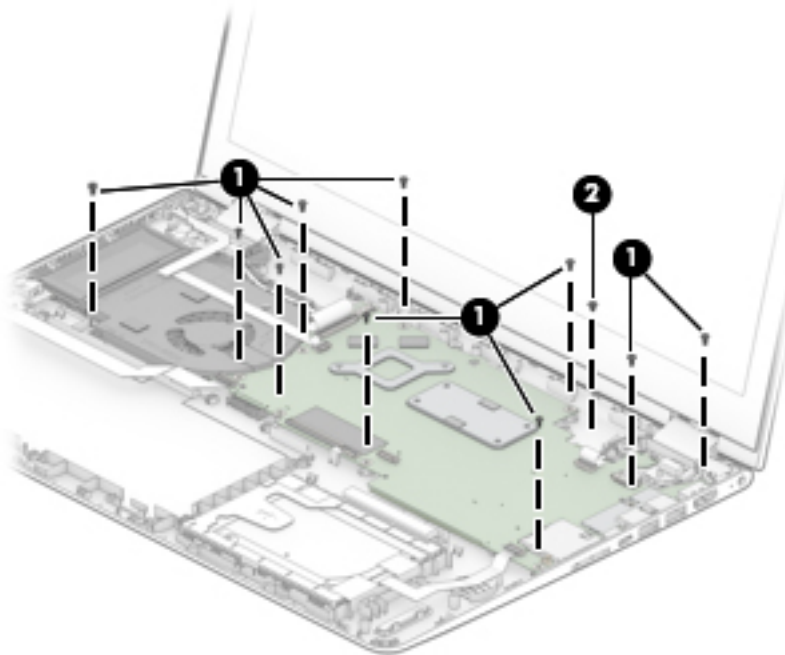

12. Lift the left side of the system board **(1)** until it rests at an angle.

13. Remove the system board (2) by sliding it up and to the left at an angle.

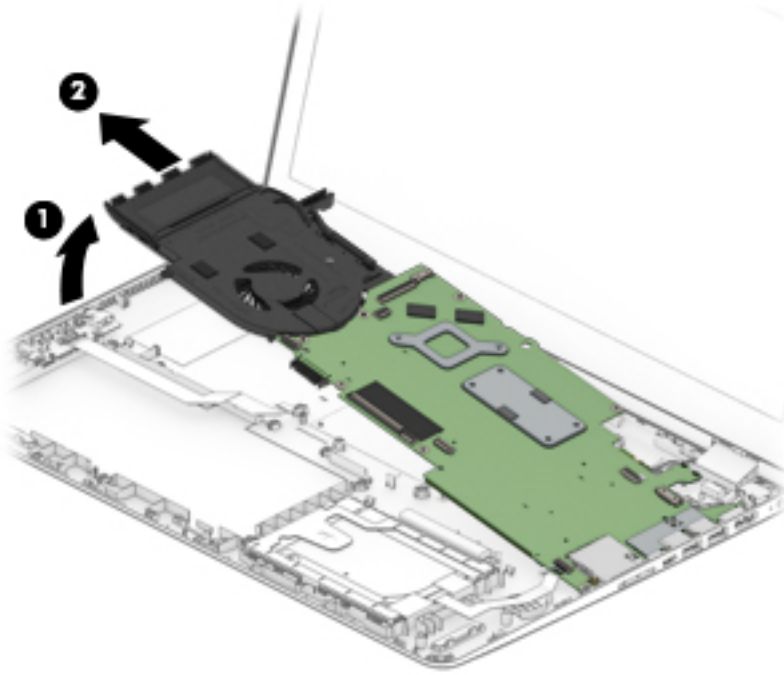

Reverse this procedure to install the system board.

WLAN module

Description	Spare part number
Intel Dual Band Wireless-AC 7265 802.11 AC 2×2 WiFi + Bluetooth 4.2 Combo Adapter (non-vPro)	901229-855
Intel Dual Band Wireless-AC 3168 802.11AC 1×1 WiFi + Bluetooth 4.2 Combo Adapter (non-vPro)	863934-855

CAUTION: To prevent an unresponsive system, replace the wireless module only with a wireless module authorized for use in the computer by the governmental agency that regulates wireless devices in your country or region. If you replace the module and then receive a warning message, remove the module to restore device functionality, and then contact technical support.

Before removing the WLAN module, follow these steps:

1. Turn off the computer. If you are unsure whether the computer is off or in Hibernation, turn the computer on, and then shut it down through the operating system.
2. Disconnect the power from the computer by first unplugging the power cord from the AC outlet, and then unplugging the AC adapter from the computer.
3. Disconnect all external devices from the computer.
4. Remove the keyboard/top cover (see [Keyboard/top cover on page 24](#)), and then remove the following components:
 - a. Battery (see [Battery on page 30](#))
 - b. Speakers (see [Speakers on page 37](#))
 - c. System board (see [System board on page 38](#))

Remove the WLAN module:

1. Turn the system board upside down with the front toward you.
2. Remove the WLAN module by pulling the module away from the slot at an angle.

NOTE: WLAN modules are designed with a notch to prevent incorrect insertion.

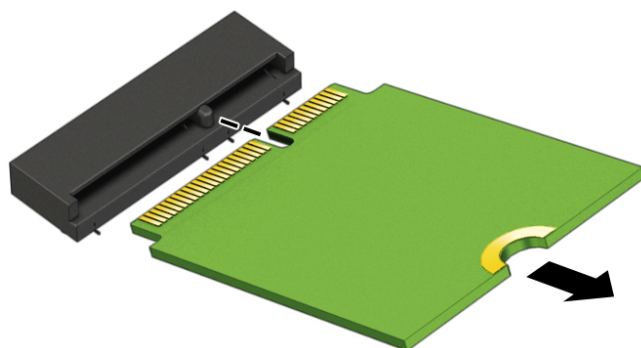

Reverse this procedure to install the WLAN module.

Fan/heat sink assembly



NOTE: The fan/heat sink assembly spare part kit includes the fan cable and replacement thermal material.

Description	Spare part number
For use only on computer models equipped with a graphics subsystem with discrete memory	924514-001
For use only on computer models equipped with a graphics subsystem with UMA memory	924513-001

Before removing the fan/heat sink assembly, follow these steps:

1. Turn off the computer. If you are unsure whether the computer is off or in Hibernation, turn the computer on, and then shut it down through the operating system.
2. Disconnect the power from the computer by first unplugging the power cord from the AC outlet, and then unplugging the AC adapter from the computer.
3. Disconnect all external devices from the computer.
4. Remove the keyboard/top cover (see [Keyboard/top cover on page 24](#)), and then remove the following components:
 - a. Battery (see [Battery on page 30](#))
 - b. Speakers (see [Speakers on page 37](#))
 - c. System board (see [System board on page 38](#))

Remove the fan/heat sink assembly:

1. Turn the system board upside down with the front toward you.
2. Disconnect the fan cable **(1)** from the system board.
3. Detach the piece of tape **(2)** that secures the fan cable to the system board.
4. Loosen the six Phillips PM2.0×6.2 captive screws **(3)** that secure the fan/heat sink assembly to the system board.



NOTE: Computer models equipped with a graphics subsystem with UMA memory will only have four screws securing the fan/heat sink assembly to the system board.

5. Remove the fan/heat sink assembly (4).

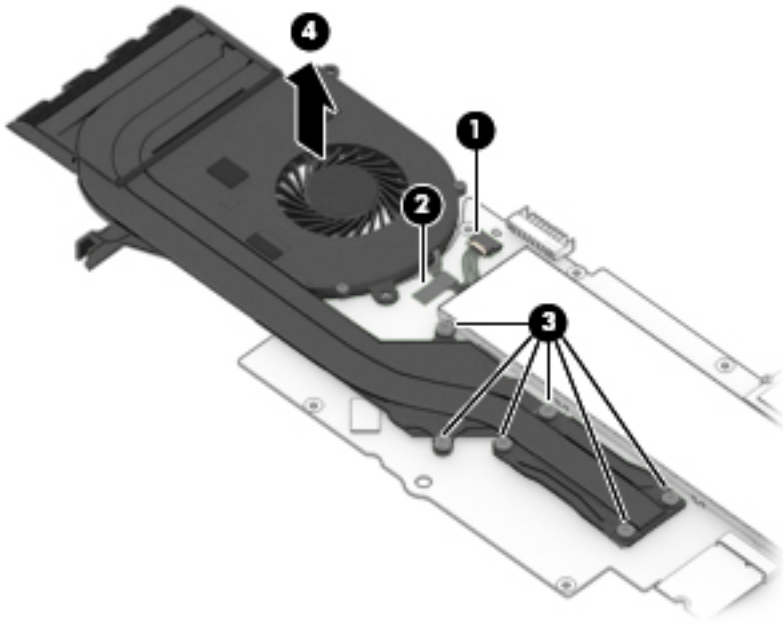

 **NOTE:** The thermal material must be thoroughly cleaned from the surfaces of the fan/heat sink assembly and the system board components each time the fan/heat sink assembly is removed. Replacement thermal material is included with the fan/heat sink assembly and system board spare part kits.

Thermal paste is used on the processor (1) and the heat sink section (2) that services it. Thermal paste is also used on the VGA component (3) and the heat sink section (4) that services it.

 **NOTE:** Computer models equipped with a graphics subsystem with UMA memory will not have the components identified by callouts 3 and 4 present on the system board and fan/heat sink assembly.

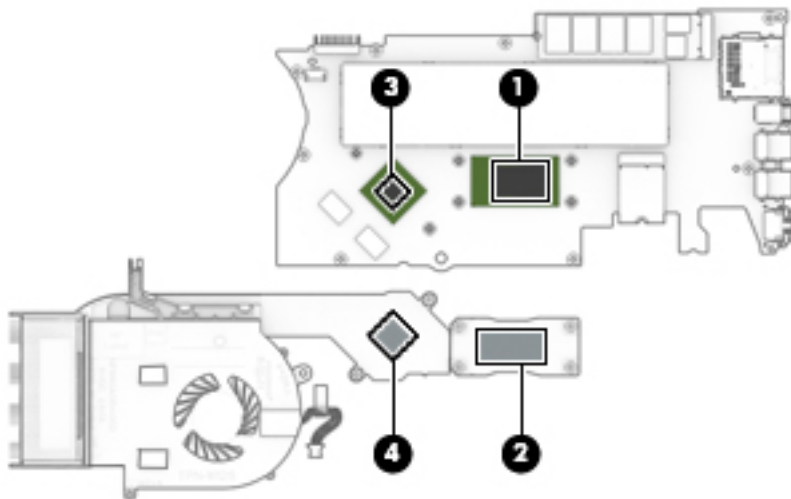

Reverse this procedure to install the fan/heat sink assembly.

Memory module

 **NOTE:** The memory module spare part kit does not include the memory module bracket. The memory module bracket is available using spare part number 925378-001.

 **NOTE:** Primary and expansion memory is installed in a side-by-side configuration in the bottom of the computer. If only one memory module is installed, it must be installed in the socket labeled 1.

Description	Spare part number
8-MB, DDR4-2400, 1.2-V	820570-005
4-MB, DDR4-2400, 1.2-V	862397-855
2-MB, DDR4-2133, 1.2-V	864271-855

Update BIOS before adding memory modules

Before adding new memory, make sure you update the computer to the latest BIOS.

 **CAUTION:** Failure to update the computer to the latest BIOS prior to installing new memory may result in various system problems.

To update BIOS:

1. Navigate to www.hp.com.
2. Click **Support & Drivers**, and then click **Drivers & Software**.
3. In the **Enter a product name/number** box, type the computer model information, and then click **Search**.
4. Click the link for the computer model.
5. Select the operating system, and then click **Next**.
6. Under **Step 2: Select a Download**, click the **BIOS** link.
7. Click the link for the most recent BIOS.
8. Click the **Download** button, and then follow the on-screen instructions.

Before removing the memory module, follow these steps:

1. Turn off the computer. If you are unsure whether the computer is off or in Hibernation, turn the computer on, and then shut it down through the operating system.
2. Disconnect the power from the computer by first unplugging the power cord from the AC outlet, and then unplugging the AC adapter from the computer.
3. Disconnect all external devices from the computer.
4. Remove the keyboard/top cover (see [Keyboard/top cover on page 24](#)), and then remove the following components:
 - a. Battery (see [Battery on page 30](#))
 - b. Speakers (see [Speakers on page 37](#))
 - c. System board (see [System board on page 38](#))

Remove the memory module:

1. Turn the system board upside down with the front toward you.

2. Remove the memory module shield.

The memory module shield is available using spare part number 925378-001.

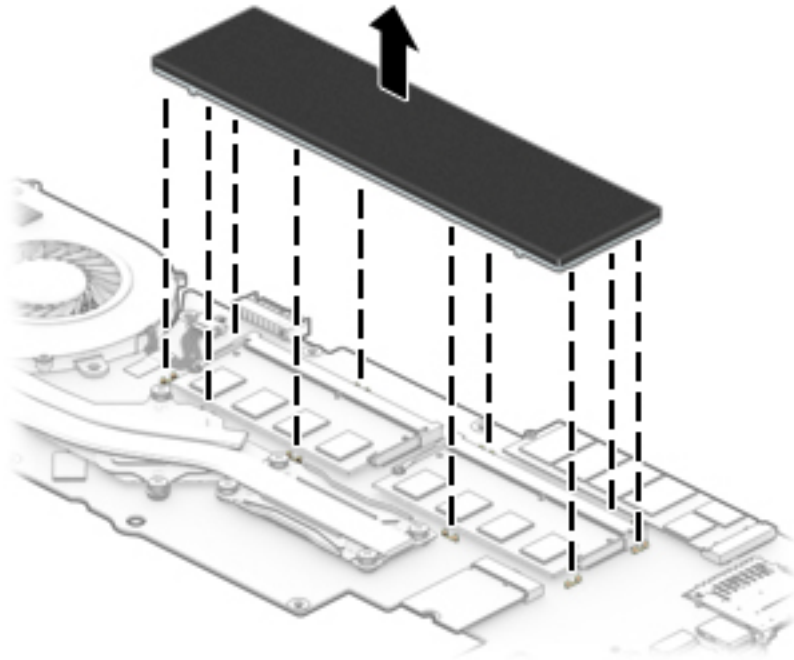

3. Spread the retaining tabs **(1)** on each side of the memory module slot to release the memory module. (The edge of the module opposite the slot rises away from the computer.)
4. Remove the memory module **(2)** by pulling the module away from the slot at an angle.

 **NOTE:** Memory modules are designed with a notch to prevent incorrect insertion.

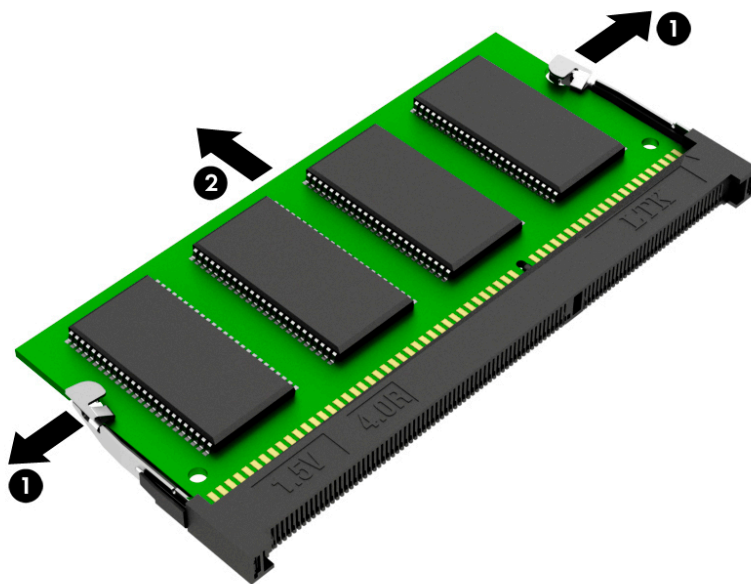

Reverse this procedure to install a memory module.

Power connector cable



NOTE: The power connector cable spare part kit does not include the power connector cable bracket. The power connector cable bracket is available using spare part number 924516-001.

Description	Spare part number
Power connector cable (does not include bracket)	808155-024

Before removing the power connector cable, follow these steps:

1. Shut down the computer. If you are unsure whether the computer is off or in Hibernation, turn the computer on, and then shut it down through the operating system.
2. Disconnect all external devices connected to the computer.
3. Disconnect the power from the computer by first unplugging the power cord from the AC outlet, and then unplugging the AC adapter from the computer.
4. Remove the keyboard/top cover (see [Keyboard/top cover on page 24](#)), and then remove the following components:
 - a. Battery (see [Battery on page 30](#))
 - b. Speakers (see [Speakers on page 37](#))
 - c. System board (see [System board on page 38](#))

Remove the power connector cable:

1. Lift the right side of the power connector cable bracket **(1)** to release the bracket from the power connector.
2. Remove the power connector cable bracket **(2)**.
3. Remove the power connector cable **(3)**.

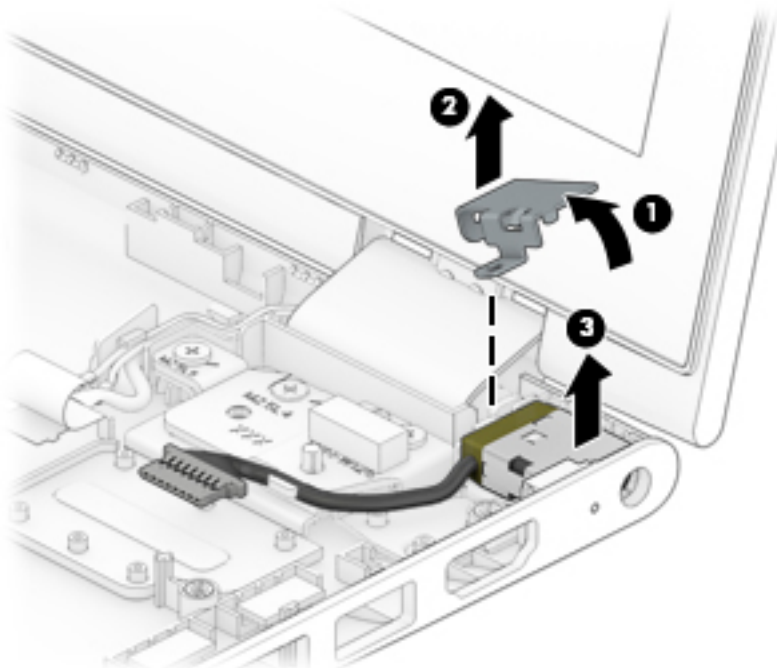

Reverse this procedure to install the power connector cable.

Display assembly

 **NOTE:** The display assembly is spared at the subcomponent level. For display assembly spare part information, see the individual removal subsections.

Before removing the display assembly, follow these steps:

1. Shut down the computer. If you are unsure whether the computer is off or in Hibernation, turn the computer on, and then shut it down through the operating system.
2. Disconnect all external devices connected to the computer.
3. Disconnect the power from the computer by first unplugging the power cord from the AC outlet, and then unplugging the AC adapter from the computer.
4. Remove the keyboard/top cover (see [Keyboard/top cover on page 24](#)), and then remove the following components:
 - a. Battery (see [Battery on page 30](#))
 - b. Speakers (see [Speakers on page 37](#))
 - c. System board (see [System board on page 38](#))

Remove the display assembly:

1. Remove the five Phillips PM2.5×5.7 screws **(1)** the Phillips PM2.5×4.6 screw **(2)** that secure the display assembly to the base enclosure.
2. Remove the display assembly **(3)**.

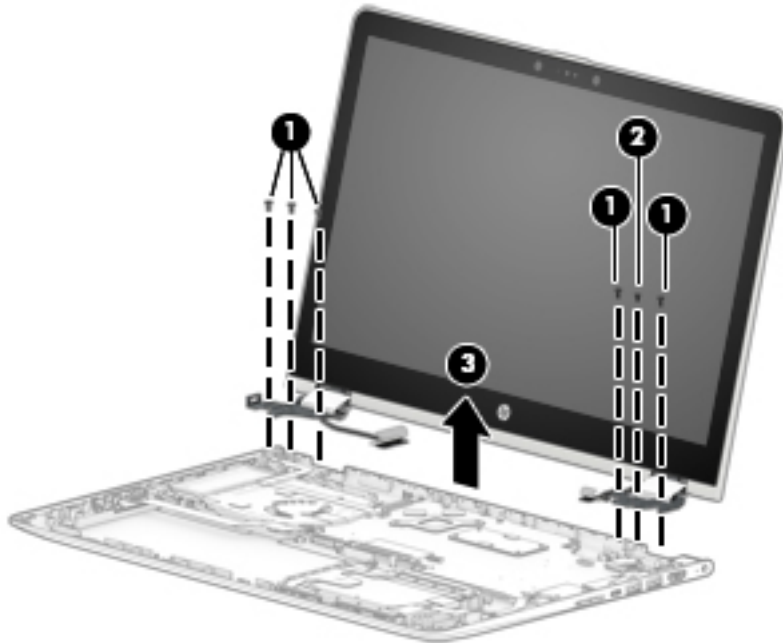

3. If it is necessary to replace the display panel assembly or any of the display assembly subcomponents:

 **NOTE:** The display panel assembly can be removed and replaced without removing the display assembly from the base enclosure.

- a. Insert a case utility tool **(1)** or similar thin, plastic tool between the top edges of the display panel assembly and the display back cover.
- b. Release the top edge of the display panel assembly **(2)** from the display back cover.
- c. Swing the display panel assembly **(3)** forward until it rests on the keyboard.

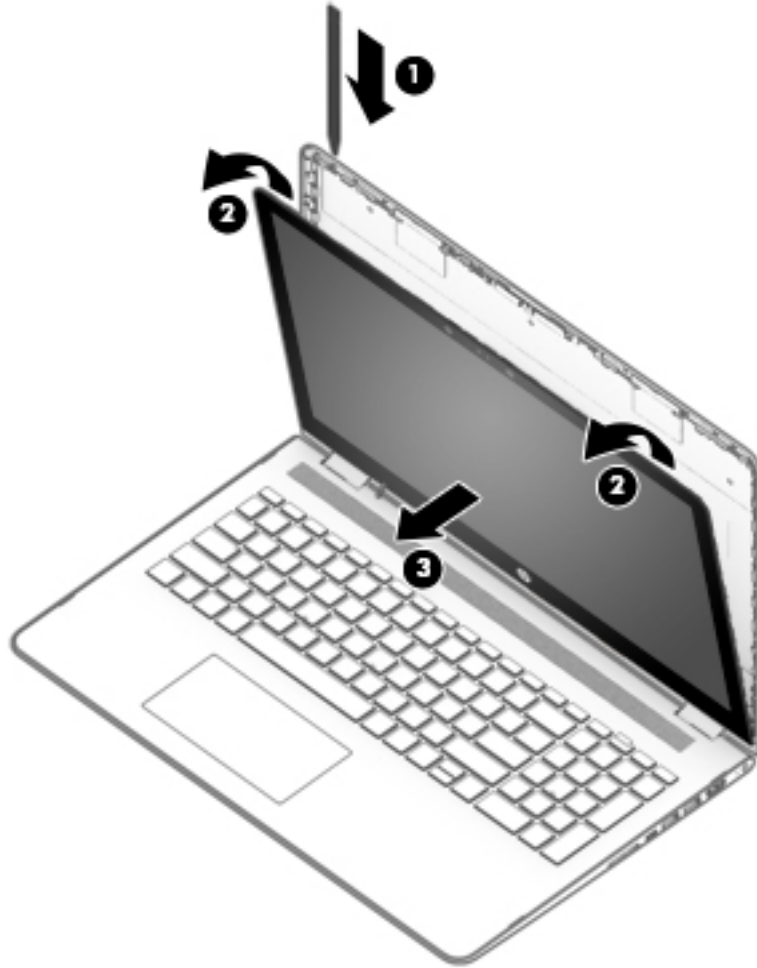

- d. Detach the two pieces of tape **(1)** that secure the TouchScreen board and TouchScreen board cables to the display panel assembly.

- e. Disconnect both ends of the TouchScreen board cable (2) from the two connectors on the TouchScreen board.

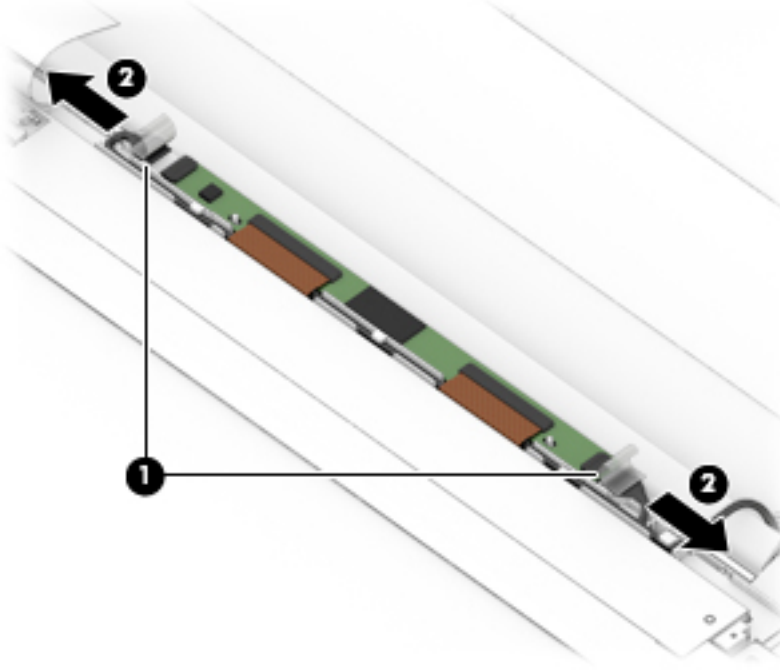

- f. Release the adhesive strip (1) that secures the display panel cable connector to the display panel.
- g. Disconnect the display panel cable (2) from the display panel.
- h. Remove the display panel assembly (3).

The display panel assembly is available using the following spare part numbers:

- 924530-001 – 15.6-in, FHD, WLED, BrightView, TouchScreen equipped with an FHD infrared camera
- 925711-001 – 15.6-in, FHD, WLED, BrightView, TouchScreen equipped with an HD non-infrared camera
- 924531-001 – 15.6-in, HD, WLED, AntiGlare, TouchScreen equipped with an HD non-infrared camera

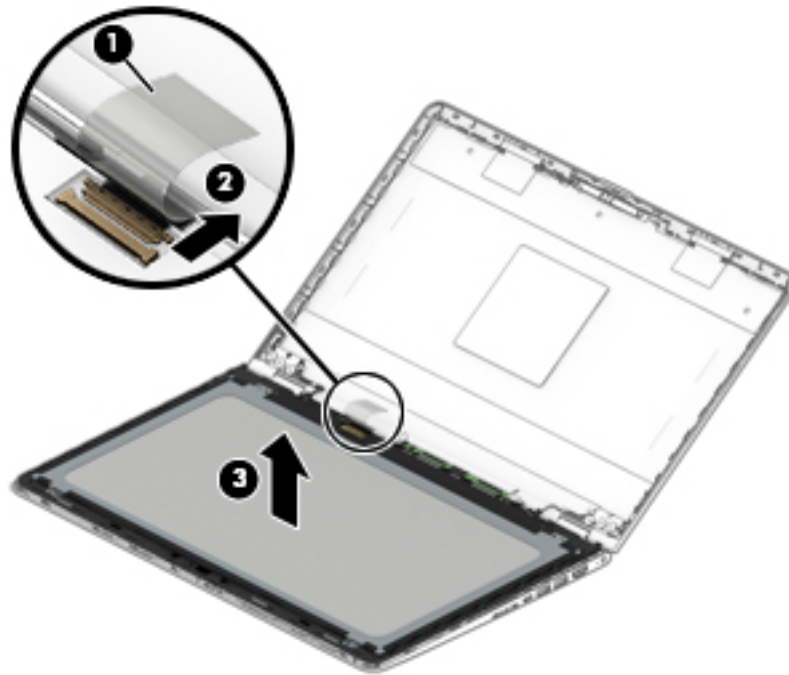

4. If it is necessary to replace the TouchScreen board:



NOTE: The TouchScreen board can be removed and replaced without removing the display assembly from the base enclosure.

- a. Remove the display panel assembly.



CAUTION: Before turning the display panel assembly upside down, make sure the work surface is clear of tools, screws, and any other foreign objects. Failure to follow this caution can result in damage to the display panel.

- b. Turn the display panel assembly upside down with the bottom edge toward you.
- c. Release the two ZIF connectors (1) to which display panel cables are connected, and then disconnect the display panel cables from the TouchScreen board.

- d. Remove the TouchScreen board (2).

The TouchScreen board is available using spare part number 929145-001 and includes the G-sensor board.

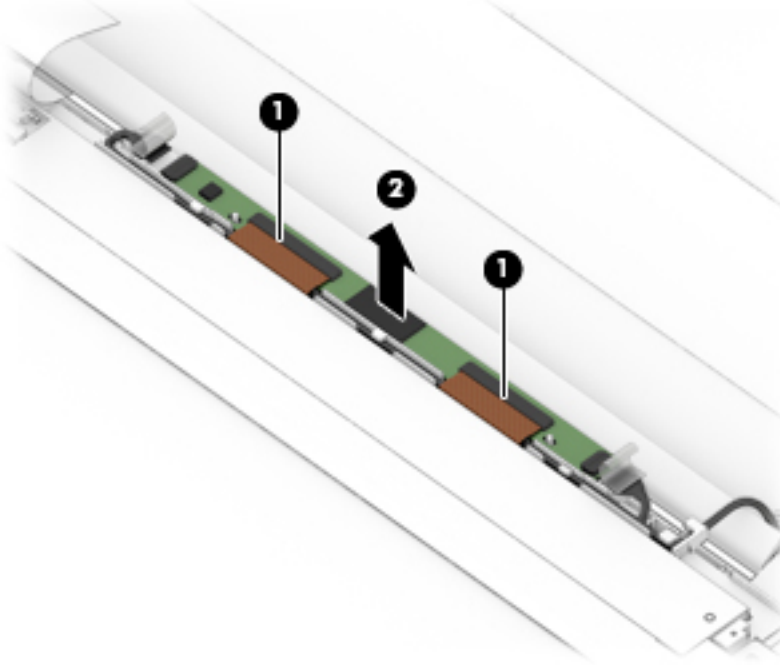

5. If it is necessary to replace the webcam/microphone module:

 **NOTE:** The webcam/microphone module can be removed and replaced without removing the display assembly from the base enclosure.

- a. Remove the display panel assembly.
- b. Disconnect the webcam/microphone module cable (1) from the webcam/microphone module.

- c. Detach the webcam/microphone module **(2)** from the display back cover. (The webcam/microphone module is attached to the display back cover with double-sided adhesive.)

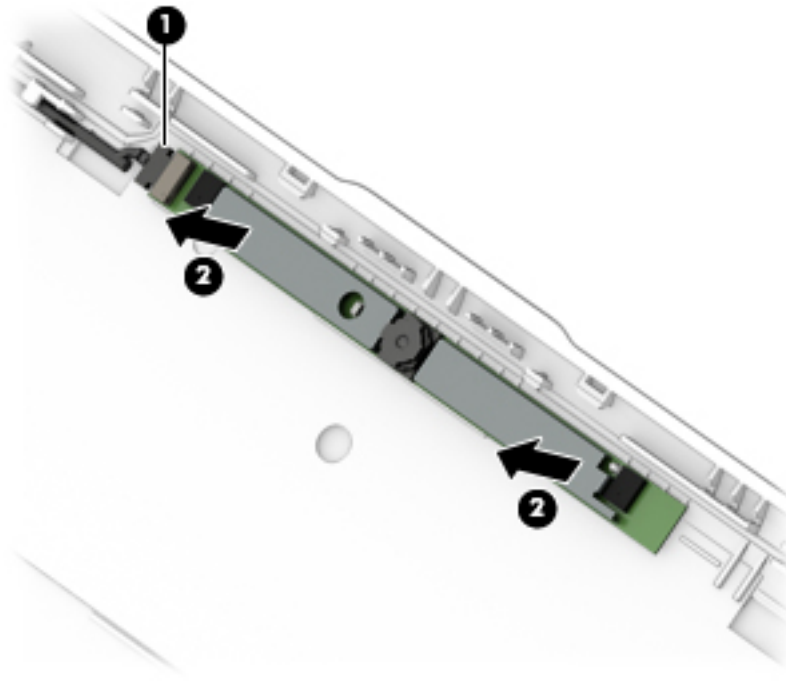

- d. Remove the webcam/microphone module.

The webcam/microphone module is available using spare part numbers 924477-001 (FHD infrared webcam/microphone module) and 924478-001 (HD non-infrared webcam/microphone module).

6. If it is necessary to replace the display hinges:



NOTE: It is necessary to remove the display assembly to remove and replace the display hinge.

- a. Remove the display panel assembly.
- b. Remove the six Phillips PM2.5×2.9 broad head screws **(1)** that secure the hinges to the display back cover.
- c. Rotate the hinges **(2)** toward the inside of the display back cover to release them from the display back cover.

d. Remove the display hinges (3).

The display hinges are available using spare part numbers 924519-001 (for use only on computer models equipped with an FHD display panel) and 924518-001 (for use only on computer models equipped with an HD display panel).

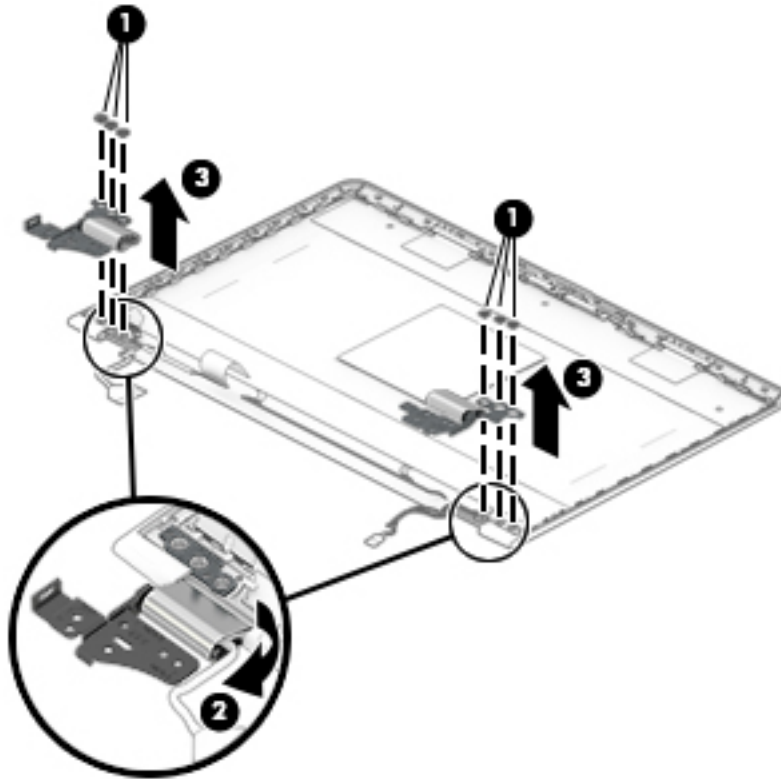

7. If it is necessary to replace the display hinge covers:

 **NOTE:** It is necessary to remove the display assembly to remove and replace the display hinge covers.

- a.** Remove the display panel assembly.
- b.** Remove the display hinge.
- c.** Remove the Phillips PM2.0×4.0 screw **(1)** that secures the hinge cover to the hinge.
- d.** Remove the display hinge cover **(2)**.

The display hinge covers are available using the following spare part numbers:

- 926720-001 – Left hinge cap for use only on computer models equipped with an FHD display panel
- 926721-001 – Right hinge cap for use only on computer models equipped with an FHD display panel
- 926718-001 – Left hinge cap for use only on computer models equipped with an HD display panel
- 926719-001 – Right hinge cap for use only on computer models equipped with an HD display panel

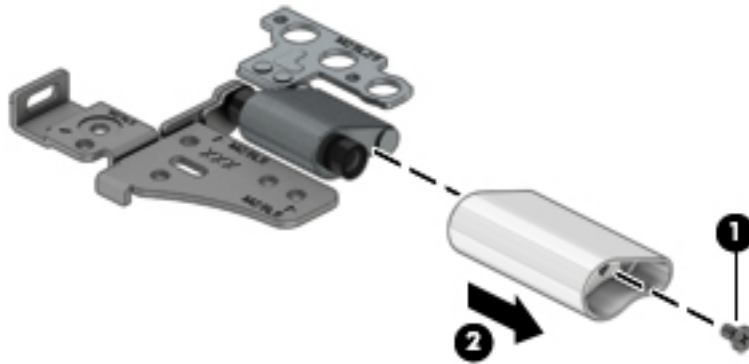

8. If it is necessary to replace the TouchScreen board cable:

 **NOTE:** It is necessary to remove the display assembly to remove and replace the TouchScreen board cable.

- a. Remove the display panel assembly.
- b. Remove the TouchScreen board cable from the cavity in the bottom edge of the display back cover.
The TouchScreen board cable is available using spare part number 924512-001 and includes the G-sensor board cable.

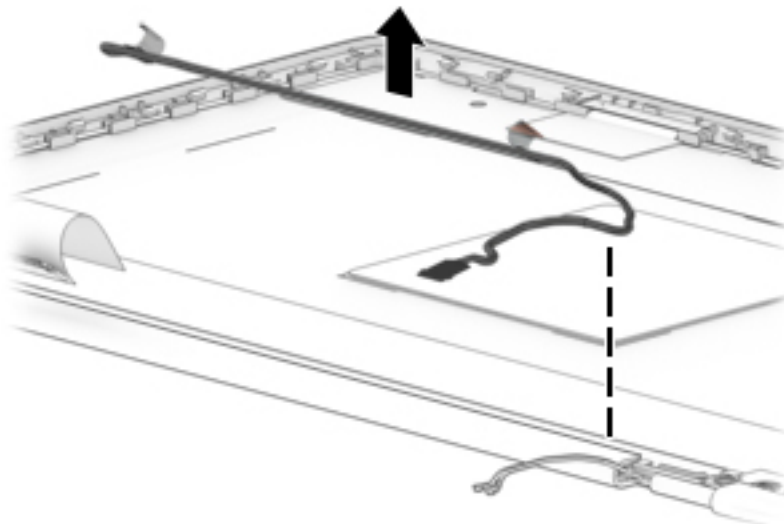

9. If it is necessary to replace the wireless antenna cables and transceivers:

- a. Remove the display panel assembly.
- b. Remove the right display hinge.
- c. Detach the wireless antenna transceivers **(1)** from the display back cover. (The wireless antenna transceivers are attached to the display back cover with double-sided adhesive.)
- d. Release the shielding material **(2)** that secures the wireless antenna cables to the display back cover.
- e. Release the wireless antenna cables from the retention clips **(3)** and routing channel built into the top, right, and bottom edges of the display back cover.

- f. Remove the wireless antenna cables and transceivers (4).

The wireless antenna cables and transceivers are available using spare part number 924476-001.

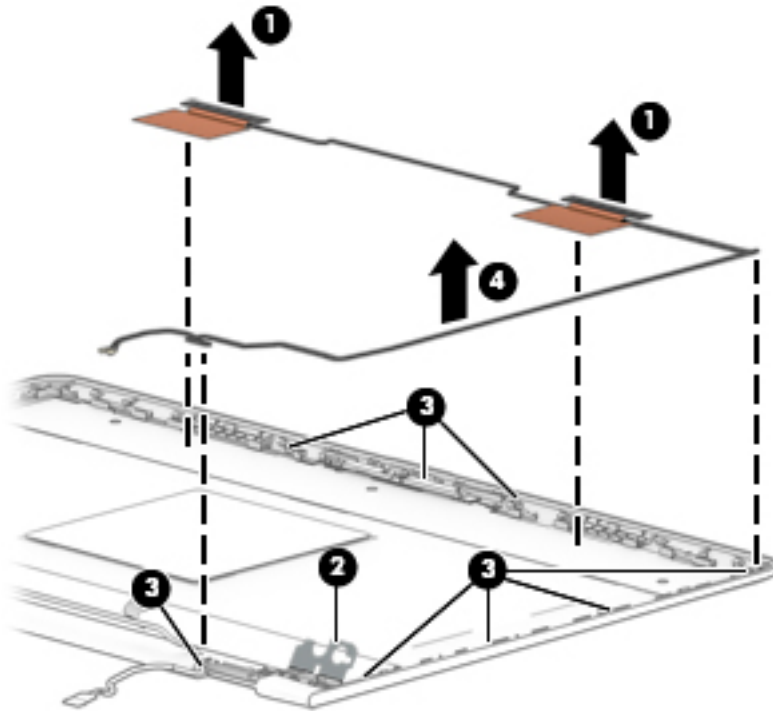

10. If it is necessary to replace the display panel cable:

- a. Remove the display panel assembly.
- b. Remove the left display hinge.
- c. Release the left wireless antenna transceiver.
- d. Disconnect the webcam/microphone module cable (1) from the webcam/microphone module.
- e. Release the shielding material (2) that secures the display panel cable to the display back cover.
- f. Release the display panel cable from the retention clips (3) and routing channel built into the top, left, and bottom edges of the display back cover.

- g.** Remove the display panel cable (4).

The display panel cable is available using spare part numbers 924507-001 (for use only on computer models equipped with an FHD display panel) and 924508-001 (for use only on computer models equipped with an HD display panel) and includes the webcam/microphone module cable.

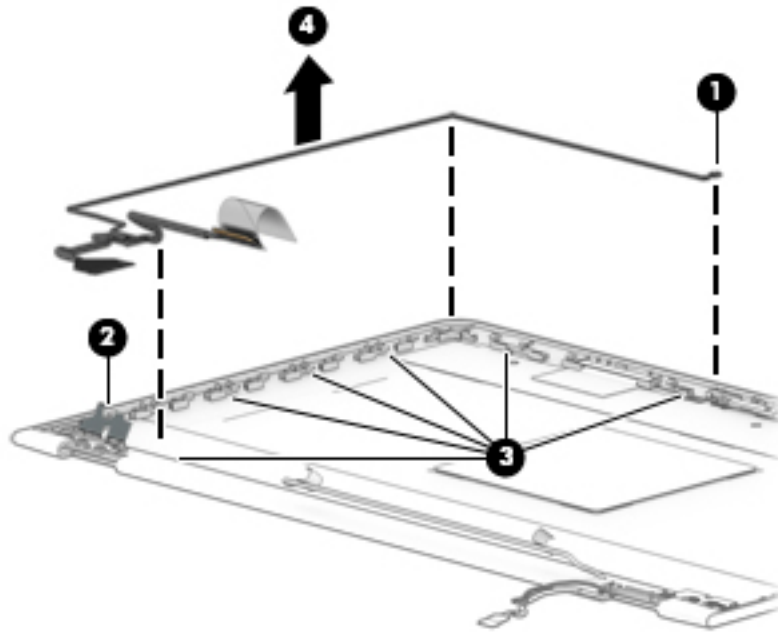

Reverse this procedure to reassemble and install the display assembly.

6 Computer Setup (BIOS), TPM, and HP Sure Start

Using Computer Setup

Computer Setup, or Basic Input/Output System (BIOS), controls communication between all the input and output devices on the system (such as disk drives, display, keyboard, mouse, and printer). Computer Setup includes settings for the types of devices installed, the startup sequence of the computer, and the amount of system and extended memory.

 **NOTE:** Use extreme care when making changes in Computer Setup. Errors can prevent the computer from operating properly.

Starting Computer Setup

 **NOTE:** An external keyboard or mouse connected to a USB port can be used with Computer Setup only if USB legacy support is enabled.

To start Computer Setup, follow these steps:

- ▲ Start Computer Setup.
 - Computers or tablets with keyboards:
 - ▲ Turn on or restart the computer, and when the HP logo appears, press **F10** to enter Computer Setup.
 - Tablets without keyboards:
 - ▲ Turn off the tablet. Press the power button in combination with the volume down button until the Startup menu is displayed, and then tap **F10** to enter Computer Setup.

Navigating and selecting in Computer Setup

- To select a menu or a menu item, use the **tab** key and the keyboard arrow keys and then press **enter**, or use a pointing device to select the item.

 **NOTE:** On tablets without keyboards, you can use your finger to make selections.

- To scroll up and down, select the up arrow or the down arrow in the upper-right corner of the screen, or use the up arrow key or the down arrow key on the keyboard.
- To close open dialog boxes and return to the main Computer Setup screen, press **esc**, and then follow the on-screen instructions.

To exit Computer Setup menus, choose one of the following methods:

- To exit Computer Setup menus without saving your changes:
Select the **Exit** icon in the lower-right corner of the screen, and then follow the on-screen instructions.
– or –
Select **Main**, select **Ignore Changes and Exit**, and then press [enter](#).
- To save your changes and exit Computer Setup menus:
Select the **Save** icon in the lower-right corner of the screen, and then follow the on-screen instructions.
– or –
Select **Main**, select **Save Changes and Exit**, and then press [enter](#).

Your changes go into effect when the computer restarts.

Restoring factory settings in Computer Setup

 **NOTE:** Restoring defaults will not change the hard drive mode.

To return all settings in Computer Setup to the values that were set at the factory, follow these steps:

1. Start Computer Setup. See [Starting Computer Setup on page 58](#).
2. Select **Main**, and then select **Apply Factory Defaults and Exit**.

 **NOTE:** On select products, the selections may display **Restore Defaults** instead of **Apply Factory Defaults and Exit**.

3. Follow the on-screen instructions.
4. To save your changes and exit, select the **Save** icon in the lower-right corner of the screen, and then follow the on-screen instructions.
– or –
Select **Main**, select **Save Changes and Exit**, and then press [enter](#).

Your changes go into effect when the computer restarts.

 **NOTE:** Your password settings and security settings are not changed when you restore the factory settings.

Updating the BIOS

Updated versions of the BIOS may be available on the HP website.

Most BIOS updates on the HP website are packaged in compressed files called *SoftPaqs*.

Some download packages contain a file named *Readme.txt*, which contains information regarding installing and troubleshooting the file.

Determining the BIOS version

To decide whether you need to update Computer Setup (BIOS), first determine the BIOS version on the computer.

BIOS version information (also known as *ROM date* and *System BIOS*) can be accessed by pressing **fn+esc** (if you are already in Windows) or by using Computer Setup.

1. Start Computer Setup. See [Starting Computer Setup on page 58](#).
2. Select **Main**, and then select **System Information**.
3. To exit Computer Setup without saving your changes, select the **Exit** icon in the lower-right corner of the screen, and then follow the on-screen instructions.

– or –

Select **Main**, select **Ignore Changes and Exit**, and then press **enter**.

To check for later BIOS versions, see [Downloading a BIOS update on page 60](#).

Downloading a BIOS update

 **CAUTION:** To reduce the risk of damage to the computer or an unsuccessful installation, download and install a BIOS update only when the computer is connected to reliable external power using the AC adapter. Do not download or install a BIOS update while the computer is running on battery power, docked in an optional docking device, or connected to an optional power source. During the download and installation, follow these instructions:

Do not disconnect power on the computer by unplugging the power cord from the AC outlet.

Do not shut down the computer or initiate Sleep.

Do not insert, remove, connect, or disconnect any device, cable, or cord.

1. Type `support` in the taskbar search box, and then select the HP Support Assistant app.
– or –
Select the question mark icon in the taskbar.
2. Select **Updates**, and then select **Check for updates and messages**.
3. Follow the on-screen instructions.
4. At the download area, follow these steps:
 - a. Identify the most recent BIOS update and compare it to the BIOS version currently installed on your computer. Make a note of the date, name, or other identifier. You may need this information to locate the update later, after it has been downloaded to your hard drive.
 - b. Follow the on-screen instructions to download your selection to the hard drive.
Make a note of the path to the location on your hard drive where the BIOS update is downloaded. You will need to access this path when you are ready to install the update.

 **NOTE:** If you connect your computer to a network, consult the network administrator before installing any software updates, especially system BIOS updates.

BIOS installation procedures vary. Follow any instructions that are revealed on the screen after the download is complete. If no instructions are revealed, follow these steps:

1. Type `file` in the taskbar search box, and then select **File Explorer**.
2. Select your hard drive designation. The hard drive designation is typically Local Disk (C:).
3. Using the hard drive path you recorded earlier, open the folder that contains the update.
4. Double-click the file that has an .exe extension (for example, *filename.exe*).
The BIOS installation begins.
5. Complete the installation by following the on-screen instructions.

 **NOTE:** After a message on the screen reports a successful installation, you can delete the downloaded file from your hard drive.

Changing the boot order using the f9 prompt

To dynamically choose a boot device for the current startup sequence, follow these steps:

1. Access the Boot Device Options menu:
 - Computers or tablets with keyboards:
 - ▲ Turn on or restart the computer, and when the HP logo appears, press **f9** to enter the Boot Device Options menu.
 - Tablets without keyboards:
 - ▲ Turn off the tablet. Press the power button in combination with the volume down button until the Startup menu is displayed, and then tap **F9** to enter the Boot Device Options menu.
2. Select a boot device, then press `enter`.

TPM BIOS settings (select products only)

 **IMPORTANT:** Before enabling Trusted Platform Module (TPM) functionality on this system, you must ensure that your intended use of TPM complies with relevant local laws, regulations and policies, and approvals or licenses must be obtained if applicable. For any compliance issues arising from your operation/usage of TPM which violates the above mentioned requirement, you shall bear all the liabilities wholly and solely. HP will not be responsible for any related liabilities.

TPM provides additional security for your computer. You can modify the TPM settings in Computer Setup (BIOS).

 **NOTE:** If you change the TPM setting to Hidden, TPM is not visible in the operating system.

To access TPM settings in Computer Setup:

1. Start Computer Setup. See [Starting Computer Setup on page 58](#).
2. Select **Security**, select **TPM Embedded Security**, and then follow the on-screen instructions.

Using HP Sure Start (select products only)

Select computer models are configured with HP Sure Start, a technology that continuously monitors the computer's BIOS for attacks or corruption. If the BIOS becomes corrupted or is attacked, HP Sure Start automatically restores the BIOS to its previously safe state, without user intervention.

HP Sure Start is configured and already enabled so that most users can use the HP Sure Start default configuration. The default configuration can be customized by advanced users.

To access the latest documentation on HP Sure Start, go to <http://www.hp.com/support>, and select your country. Select **Drivers & Downloads**, and then follow the on-screen instructions.

7 HP PC Hardware Diagnostics (UEFI)

HP PC Hardware Diagnostics is a Unified Extensible Firmware Interface (UEFI) that allows you to run diagnostic tests to determine whether the computer hardware is functioning properly. The tool runs outside the operating system so that it can isolate hardware failures from issues that are caused by the operating system or other software components.

When HP PC Hardware Diagnostics (UEFI) detects a failure that requires hardware replacement, a 24-digit Failure ID is generated. This ID can then be provided to support to help determine how to correct the problem.

 **NOTE:** To start diagnostics on a convertible computer, your computer must be in notebook mode and you must use the keyboard attached.

To start HP PC Hardware Diagnostics (UEFI), follow these steps:

1. Turn on or restart the computer, quickly press [esc](#).

 **NOTE:** The HP PC Hardware Diagnostics (UEFI) download instructions are provided in English only, and you must use a Windows computer to download and create the HP UEFI support environment because only .exe files are offered.

2. Press or tap [f2](#).

The BIOS searches three places for the diagnostic tools, in the following order:

- a. Connected USB drive

 **NOTE:** To download the HP PC Hardware Diagnostics (UEFI) tool to a USB drive, see [Downloading HP PC Hardware Diagnostics \(UEFI\) to a USB device on page 64](#).

- b. Hard drive
- c. BIOS

3. When the diagnostic tool opens, select the type of diagnostic test you want to run, and then follow the on-screen instructions.

 **NOTE:** If you need to stop a diagnostic test, press [esc](#).

Downloading HP PC Hardware Diagnostics (UEFI) to a USB device

 **NOTE:** The HP PC Hardware Diagnostics (UEFI) download instructions are provided in English only, and you must use a Windows computer to download and create the HP UEFI support environment because only .exe files are offered.

There are two options to download HP PC Hardware Diagnostics to a USB device.

Download the latest UEFI version

1. Go to <http://www.hp.com/go/techcenter/pcdiags>. The HP PC Diagnostics home page is displayed.
2. In the HP PC Hardware Diagnostics section, click the **Download** link, and then select **Run**.

Download any version of UEFI for a specific product

1. Go to <http://www.hp.com/support>, and then select your country. The HP Support page is displayed.
2. Click **Drivers & Downloads**.
3. In the text box, enter the product name, and then click **Go**.

– or –

Click **Find Now** to let HP automatically detect your product.

4. Select your computer, and then select your operating system.
5. In the **Diagnostic** section, follow the on-screen instructions to select and download the UEFI version you want.

8 Specifications

	Metric	U.S.
Computer dimensions		
Width	30.0 cm	11.8 in
Depth	20.6 cm	8.1 in
Height	2.1 cm	0.8 in
Weight	1.3 kg	2.9 lbs
Temperature		
Operating	5°C to 35°C	41°F to 95°F
Nonoperating	-20°C to 60°C	-4°F to 140°F
Relative humidity (noncondensing)		
Operating	10% to 90%	
Nonoperating	5% to 95%	
Maximum altitude (unpressurized)		
Operating	-15 m to 3,048 m	-50 ft to 10,000 ft
Nonoperating	-15 m to 12,192 m	-50 ft to 40,000 ft

NOTE: Applicable product safety standards specify thermal limits for plastic surfaces. The device operates well within this range of temperatures.

9 Power cord set requirements

The wide-range input feature of the computer permits it to operate from any line voltage from 100 to 120 volts AC, or from 220 to 240 volts AC.

The 3-conductor power cord set included with the computer meets the requirements for use in the country or region where the equipment is purchased.

Power cord sets for use in other countries and regions must meet the requirements of the country or region where the computer is used.

Requirements for all countries

The following requirements are applicable to all countries and regions:

- The length of the power cord set must be at least 1.0 m (3.3 ft) and no more than 2.0 m (6.5 ft).
- All power cord sets must be approved by an acceptable accredited agency responsible for evaluation in the country or region where the power cord set will be used.
- The power cord sets must have a minimum current capacity of 10 amps and a nominal voltage rating of 125 or 250 V AC, as required by the power system of each country or region.
- The appliance coupler must meet the mechanical configuration of an EN 60 320/IEC 320 Standard Sheet C13 connector for mating with the appliance inlet on the back of the computer. Requirements for all countries 113

Requirements for specific countries and regions

Country/region	Accredited agency	Applicable note number
Australia	EANSW	1
Austria	OVE	1
Belgium	CEBC	1
Canada	CSA	2
Denmark	DEMKO	1
Finland	FIMKO	1
France	UTE	1
Germany	VDE	1
Italy	IMQ	1
Japan	METI	3
The Netherlands	KEMA	1
Norway	NEMKO	1
The People's Republic of China	COC	5

Country/region	Accredited agency	Applicable note number
South Korea	EK	4
Sweden	CEMKO	1
Switzerland	SEV	1
Taiwan	BSMI	4
The United Kingdom	BSI	1
The United States	UL	2

- 1.** The flexible cord must be Type H05VV-F, 3-conductor, 1.0-mm² conductor size. Power cord set fittings (appliance coupler and wall plug) must bear the certification mark of the agency responsible for evaluation in the country or region where it will be used.
- 2.** The flexible cord must be Type SPT-3 or equivalent, No. 18 AWG, 3-conductor. The wall plug must be a two-pole grounding type with a NEMA 5-15P (15 A, 125 V) or NEMA 6-15P (15 A, 250 V) configuration.
- 3.** The appliance coupler, flexible cord, and wall plug must bear a “T” mark and registration number in accordance with the Japanese Dentori Law. The flexible cord must be Type VCT or VCTF, 3-conductor, 1.00-mm² conductor size. The wall plug must be a two-pole grounding type with a Japanese Industrial Standard C8303 (7 A, 125 V) configuration.
- 4.** The flexible cord must be Type RVV, 3-conductor, 0.75-mm² conductor size. Power cord set fittings (appliance coupler and wall plug) must bear the certification mark of the agency responsible for evaluation in the country or region where it will be used.
- 5.** The flexible cord must be Type VCTF, 3-conductor, 0.75-mm² conductor size. Power cord set fittings (appliance coupler and wall plug) must bear the certification mark of the agency responsible for evaluation in the country or region where it will be used.

10 Recycling

When a non-rechargeable or rechargeable battery has reached the end of its useful life, do not dispose of the battery in general household waste. Follow the local laws and regulations in your area for battery disposal.

HP encourages customers to recycle used electronic hardware, HP original print cartridges, and rechargeable batteries. For more information about recycling programs, see the HP Web site at <http://www.hp.com/recycle>.

Index

A

- AC adapter, spare part numbers 18
- antenna
 - location 4
 - removal 55
 - spare part number 56
 - spare part numbers 17
- audio jack board
 - removal 34
 - spare part number 13, 34
- audio jack board cable
 - removal 33
 - spare part number 13, 33, 34
- audio, product description 2, 3
- audio-in jack 7
- audio-out jack 7

B

- base enclosure, spare part numbers 15
- battery
 - removal 30
 - spare part number 12, 30
- BIOS
 - determining version 60
 - downloading an update 60
 - updating 60
- bottom component 8

C

- cables, service considerations 19
- chipset, product description 1
- components
 - bottom 8
 - display 4
 - left side 6
 - right side 7
 - speakers 5
 - TouchPad 5
- computer major components 10
- Computer Setup
 - navigating and selecting 58
 - restoring factory settings 59
- connectors, service considerations 19

D

- display assembly
 - removal 48
 - spare part numbers 48
 - subcomponents 16
- display components 4
- display enclosure, spare part number 17
- display panel assembly
 - removal 48
 - spare part numbers 50
- display panel cable
 - removal 56
 - spare part numbers 17, 57
- Display Panel Kit
 - spare part numbers 16
- display panel, product description 1
- display switch 4
- drives
 - precautions 20
 - preventing damage 20

E

- electrostatic discharge 21
- equipment guidelines 23

F

- fan/heat sink assembly
 - removal 43
 - spare part numbers 14, 43

G

- G-sensor board cable
 - spare part number 55
- graphics, product description 1
- grounding guidelines 21
- guidelines
 - equipment 23
 - grounding 21
 - packaging 22
 - transporting 22
 - workstation 22

H

- hard drive
 - product description 2
 - removal 31
 - spare part numbers 13, 31
- hard drive counterbalance weight, spare part number 13
- hard drive rubber sleeve
 - removal 32
 - spare part number 13, 31
- HDMI port 7
- HDMI-to-VGA adapter, spare part number 18
- headphone jack 7
- hinge
 - removal 53
 - spare part numbers 17, 54
- hinge cover
 - removal 54
 - spare part numbers 16, 54
- HP PC Hardware Diagnostics (UEFI) using 63

J

- jacks
 - audio-in 7
 - audio-out 7
 - headphone 7
 - microphone 7

K

- keyboard, product description 3
- keyboard/top cover
 - removal 24
 - spare part numbers 11, 12, 24

L

- left-side component 6
- legacy support, USB 58
- lights
 - power 7
 - webcam 4

- M**
- memory module
 - product description 1, 2
 - removal 45
 - spare part numbers 14, 45
- memory module bracket
 - spare part number 45
- memory module shield
 - removal 46
 - spare part number 14, 46
- microphone
 - location 4
 - product description 2, 3
- microphone jack 7
- model name 1

- O**
- operating system, product
 - description 3
- optical drive
 - product description 2
- optical drive, spare part number 18

- P**
- packaging guidelines 22
- plastic parts, service
 - considerations 19
- pointing device, product
 - description 3
- ports
 - HDMI 7
 - product description 3
 - USB 7
- power button board
 - removal 36
 - spare part number 13, 36
- power button board cable
 - removal 35
 - spare part number 13, 35, 36
- power connector cable
 - removal 47
 - spare part number 15, 47
- power connector cable bracket
 - removal 47
 - spare part number 15, 47
- power cord
 - set requirements 66
- power light 7
- power requirements, product
 - description 3
- processor, product description 1
- product description
 - audio 2, 3
 - chipset 1
 - display panel 1
 - external media cards 3
 - graphics 1
 - hard drive 2
 - keyboard 3
 - memory module 1, 2
 - microphone 2, 3
 - operating system 3
 - optical drive 2
 - pointing device 3
 - ports 3
 - power requirements 3
 - processors 1
 - product name 1
 - security 3
 - sensors 3
 - serviceability 3
 - solid-state drive 2
 - storage 2
 - video 2, 3
 - wireless 3
- product name 1

- R**
- removal/replacement
 - procedures 24
- right-side components 7
- rubber feet
 - removal 25
 - spare part numbers 25
- Rubber Foot Kit, spare part
 - numbers 15, 18, 25

- S**
- screw cover
 - removal 25
 - spare part numbers 25
- Screw Kit, spare part number 18
- Screw Mylar Kit, spare part
 - numbers 15, 18, 25
- security cable slot 6
- security, product description 3
- sensors, product description 3
- service considerations
 - cables 19
 - connectors 19
 - plastic parts 19
- serviceability, product description 3
- setup utility
 - navigating and selecting 58
 - restoring factory settings 59
- solid-state drive
 - product description 2
 - spare part numbers 14
- solid-state drive counterbalance
 - weight, spare part number 15
- Solid-State Drive Rubber Kit, spare
 - part number 15
- speakers
 - components 5
 - locations 5, 8
 - removal 37
 - spare part number 13, 37
- storage, product description 2
- stylus, spare part number 18
- Sure Start
 - using 62
- system board
 - removal 38
 - spare part numbers 13, 38

- T**
- tools required 19
- TouchPad
 - removal 29
 - spare part number 12, 29
- TouchPad bracket
 - spare part number 12, 29
- TouchPad cable
 - removal 28
 - spare part number 12, 28, 29
- TouchPad component 5
- TouchPad zone 5
- TouchScreen board
 - removal 51
 - spare part number 16, 52
- TouchScreen board cable
 - removal 55
 - spare part number 17, 55
- TPM settings 62
- transporting guidelines 22

- U**
- USB legacy support 58
- USB port 7

USB-to-Gigabit RJ45 adapter, spare
part number 18
USB-C-to-USB-A dongle, spare part
number 18

V

video, product description 2, 3

W

webcam light 4
webcam, location 4
webcam/microphone module
removal 52
spare part numbers 16, 53
webcam/microphone module cable
spare part numbers 57
wireless antenna
location 4
removal 55
spare part number 56
spare part numbers 17
wireless, product description 3
WLAN antenna
location 4
removal 55
spare part number 17, 56
WLAN module
removal 42
spare part numbers 14, 42
workstation guidelines 22