

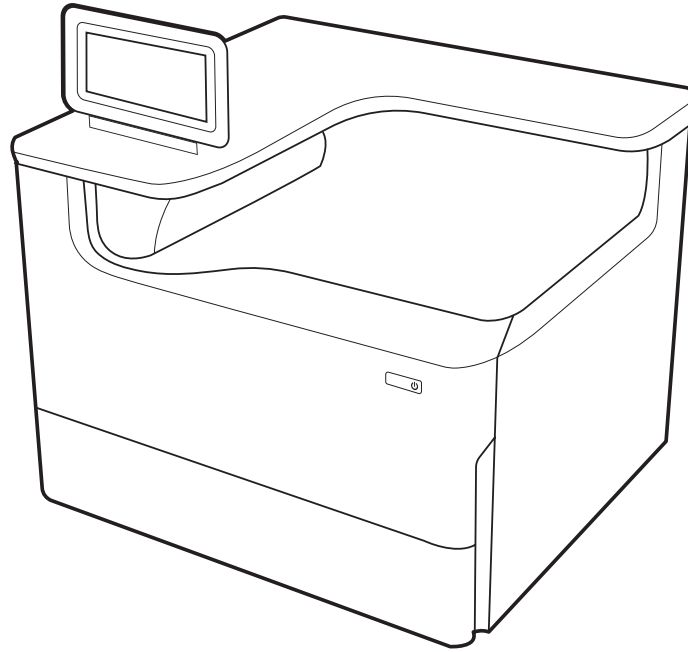

HP PageWide Managed Color E75160 HP PageWide Managed Color P75250



E75160dn
P75250dn

EN Installation Guide
FR Guide d'installation

ES Guía de instalación
PT Guia de instalação

ES Lea esto primero



support.hp.com
www.hp.com/videos/PageWide
www.hp.com/support/pwcolorE75160
www.hp.com/support/pwcolorP75250

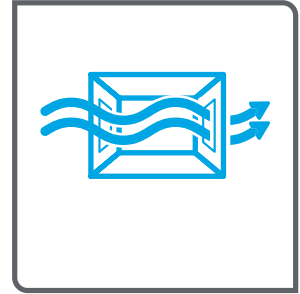
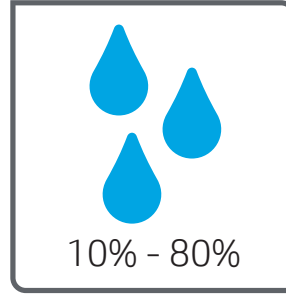
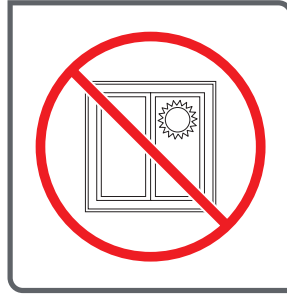
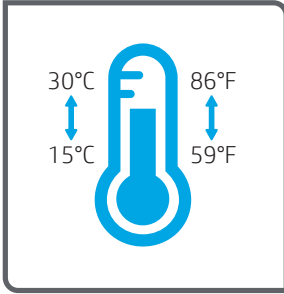

EN Select a sturdy, well-ventilated, dust-free area, away from direct sunlight to position the printer.

FR Choisissez un support solide et un endroit propre, bien aéré et à l'abri du rayonnement direct du soleil pour placer votre imprimante.

ES Busque una superficie sólida en un lugar bien ventilado, sin polvo y alejado de la luz solar directa para colocar la impresora.

PT Escolha um local firme, bem ventilado, sem poeira e longe da exposição direta à luz do sol para instalar a impressora.

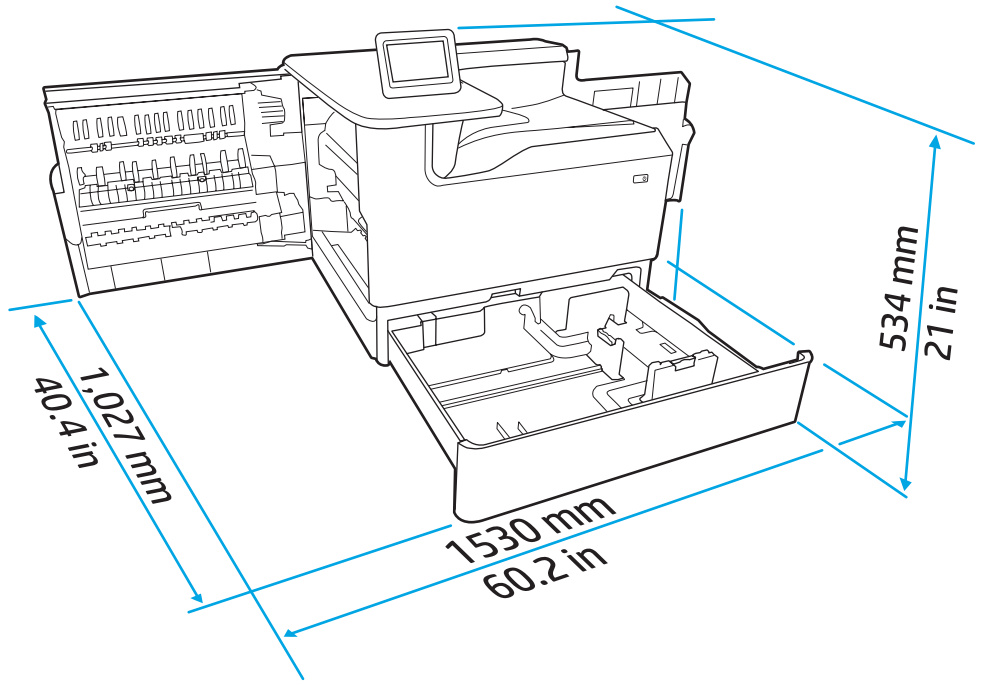
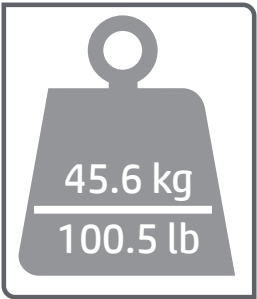
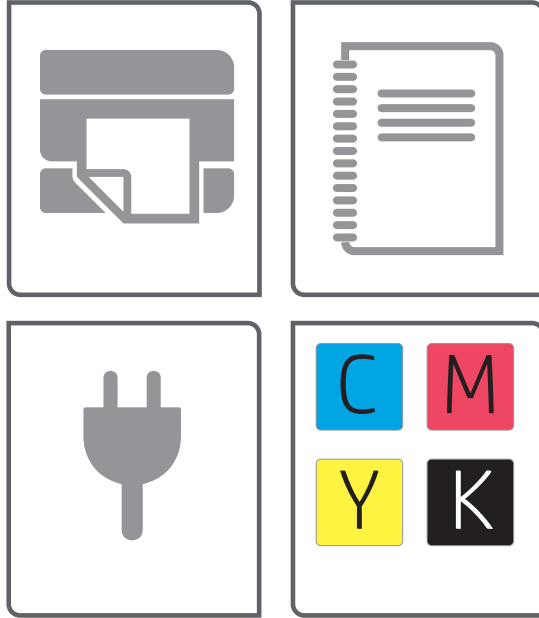
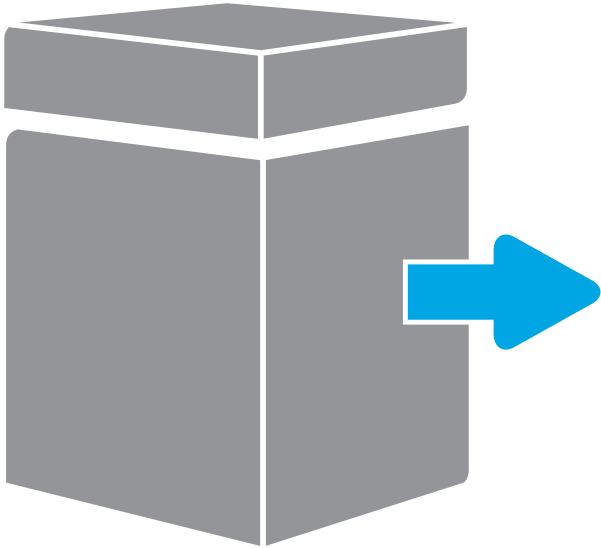

1

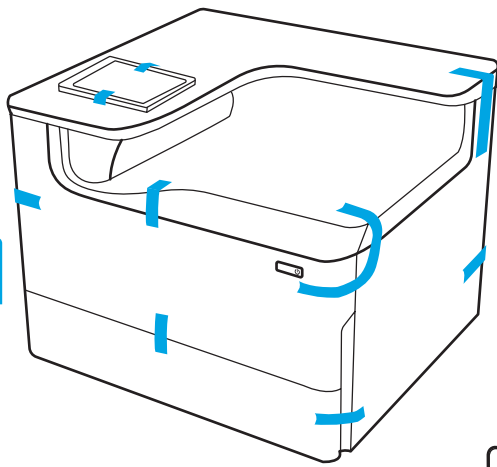

1.1

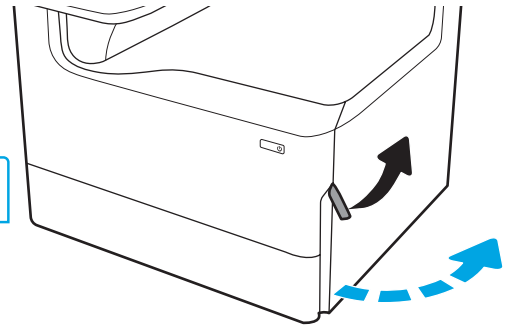

1.2

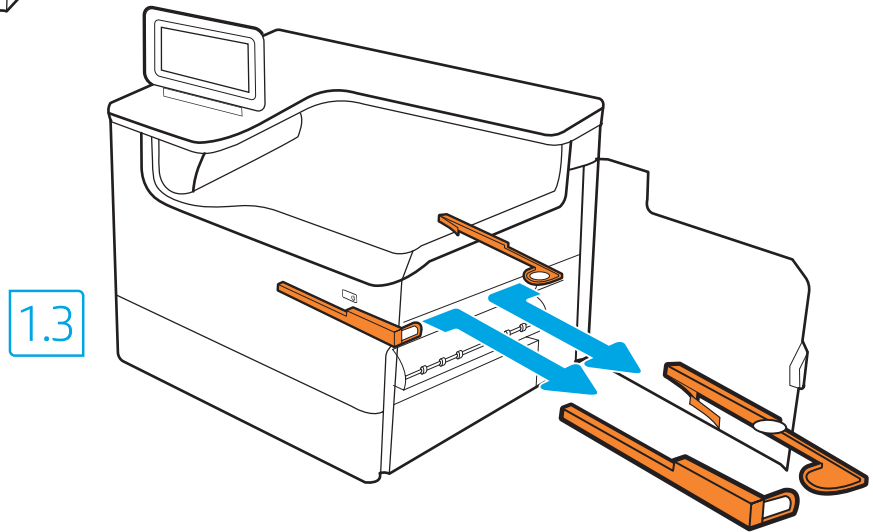

1.3

EN Remove all tape, packing material and orange restraints.

ES Retire la cinta, el material de embalaje y las contenciones naranjas.

FR Retirez le ruban adhésif, le matériau d'emballage et les pièces de retenue orange.

PT Remova todas as fitas, materiais de embalagem e retenções na cor laranja.

2

2.1

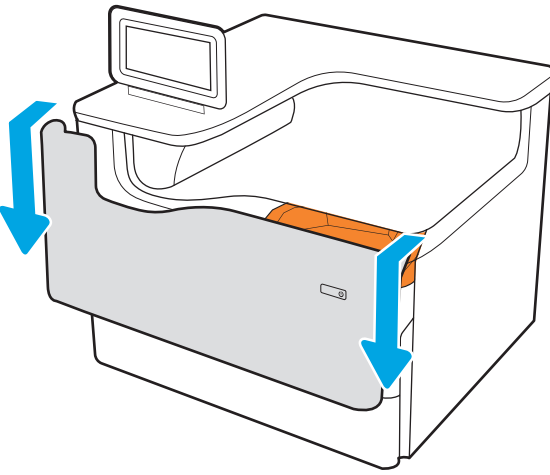

2.2

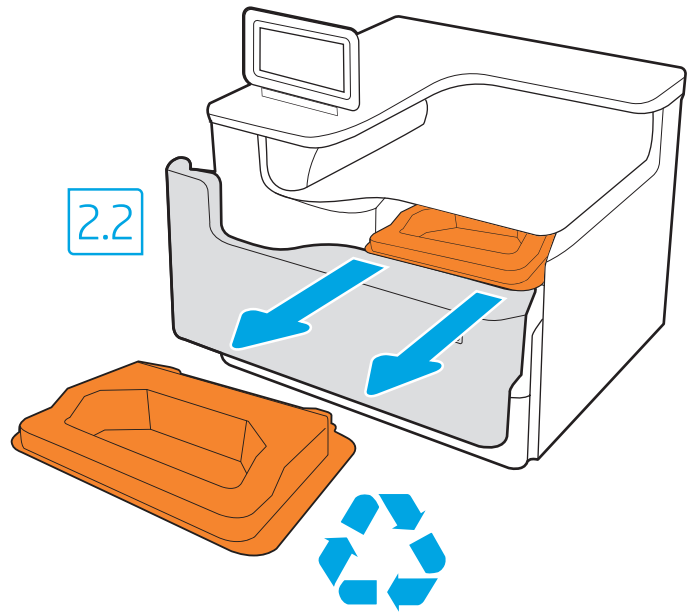

2.3

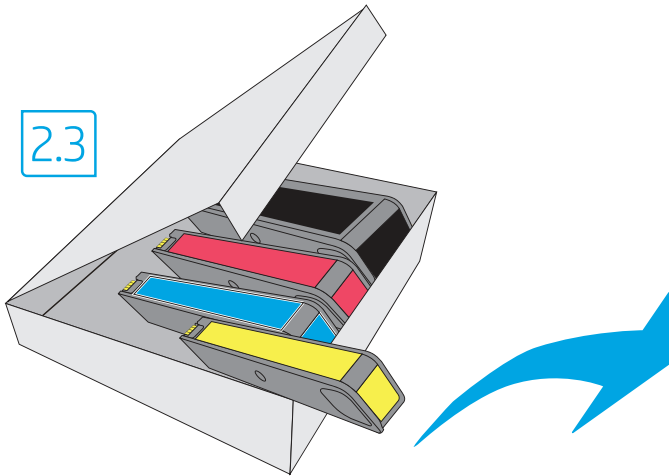

2.4

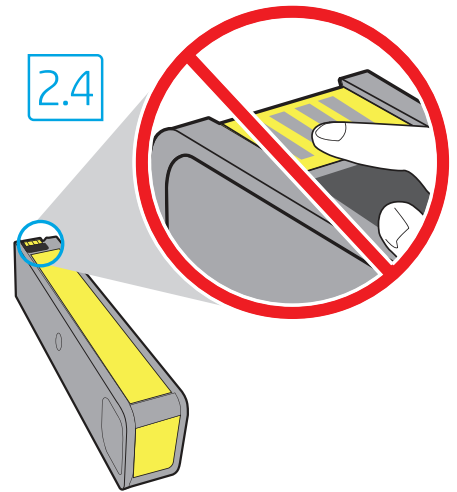

2.5

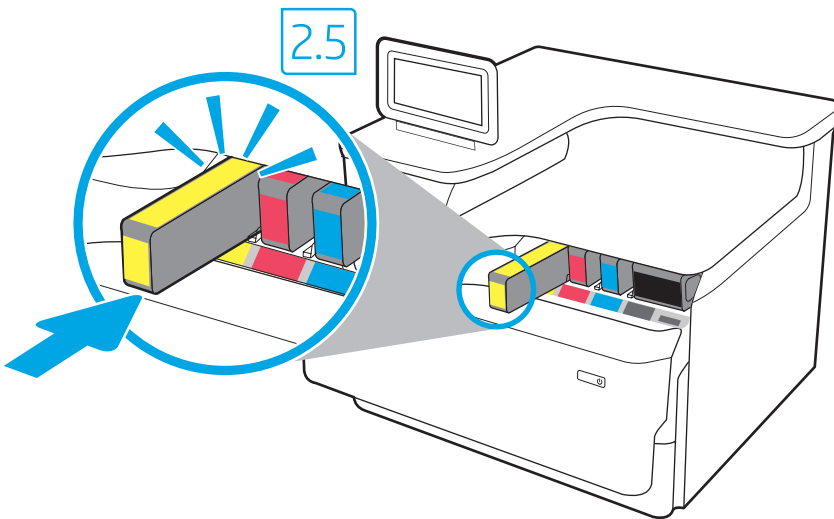

2.6

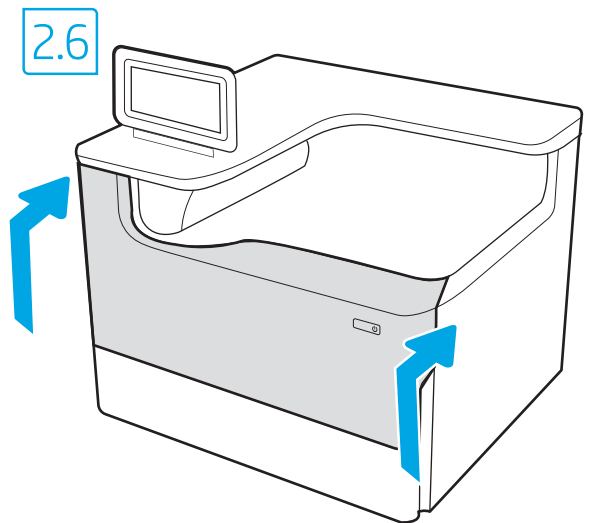

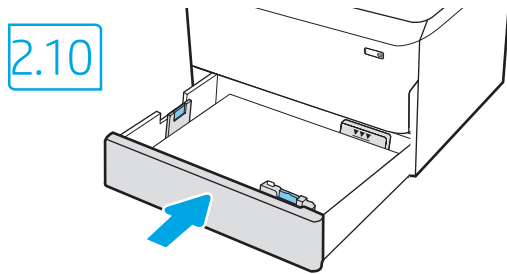
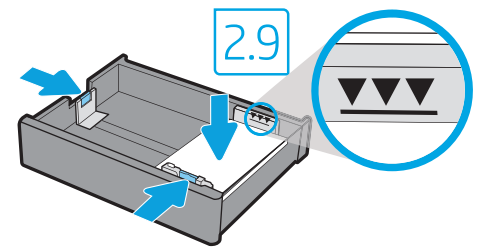
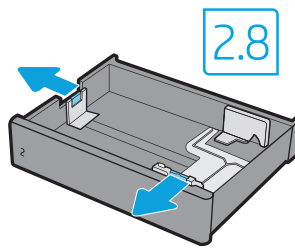
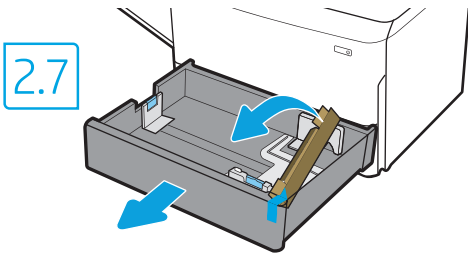

EN **CAUTION:** Use Letter/A4 paper in Tray 2 to initialize the printer. The printer will not initialize correctly with Tabloid/A3 paper loaded in Tray 2.

FR **ATTENTION :** Utilisez du papier Lettre/A4 dans le bac à papier 2 pour initialiser l'imprimante. L'imprimante ne s'initialisera pas correctement avec du papier Tabloid/A3 chargé dans le bac à papier 2.

ES **PRECAUCIÓN:** Coloque papel carta o A4 en la bandeja 2 para iniciar la impresora. La impresora no iniciará correctamente si tiene papel doble carta o A3 cargado en la bandeja 2.

PT **CUIDADO:** Use papel Carta/A4 na Bandeja 2 para inicializar a impressora. A impressora não inicializará corretamente com papel Tabloid/A3 carregado na Bandeja 2.

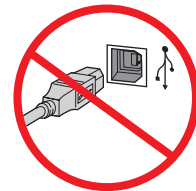
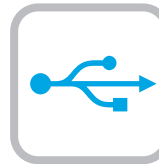
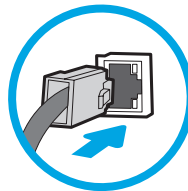
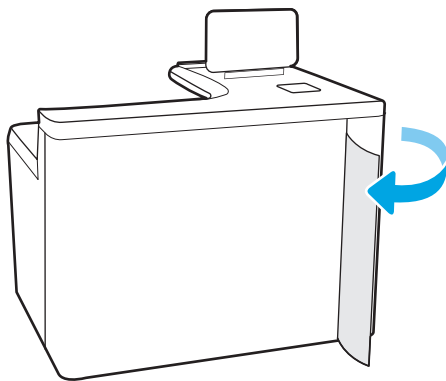

EN If you are connecting to a network, connect the network cable now. **CAUTION:** Do not connect the USB cable now. **NOTE:** The cables are not included with the printer.

FR Si vous vous connectez à un réseau, branchez le câble réseau maintenant. **ATTENTION :** Ne connectez pas le câble USB pour le moment. **REMARQUE :** Les câbles ne sont pas fournis avec l'imprimante.

ES Si se está conectando a una red, conecte ahora el cable de red. **PRECAUCIÓN:** No conecte todavía el cable USB. **NOTA:** Los cables no se incluyen con la impresora.

PT Se você estiver se conectando a uma rede, conecte o cabo de rede agora. **CUIDADO:** Não conecte o cabo USB agora. **NOTA:** Os cabos não são fornecidos com a impressora.

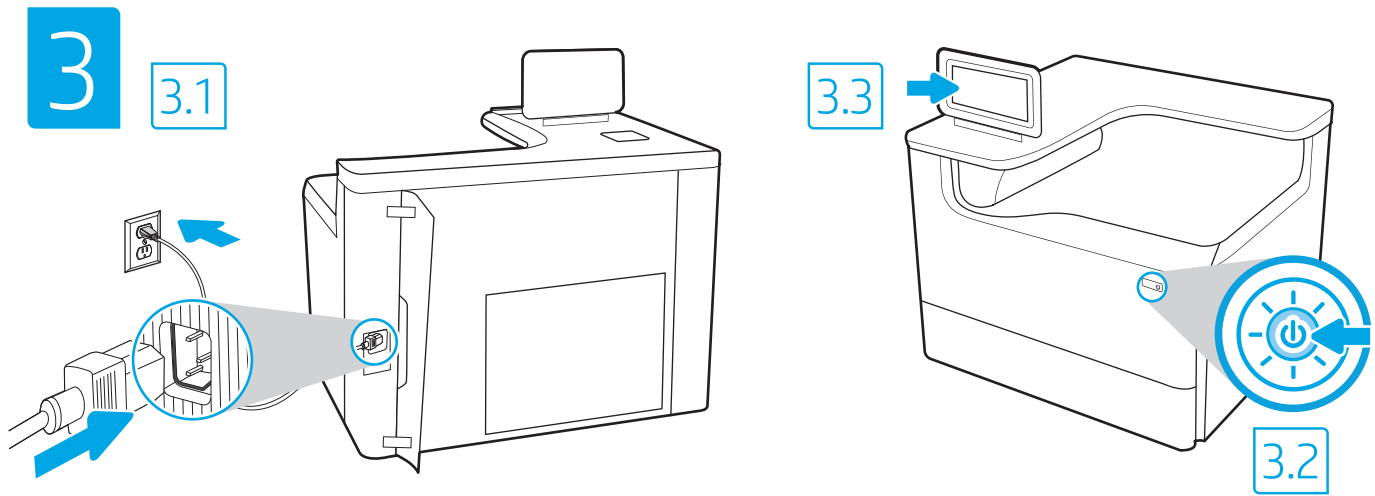

EN **3.1** Connect the power cable between the printer and a grounded AC outlet. **3.2** Turn on the printer. **3.3** On the Initial Setup screen, set the language, the location, the date/time format, and other features.

NOTE: For advanced setup for network-connected printers, enter the printer IP address in the address bar of a web browser after the printer is in a ready state. To find the IP address, select the Information **i** button, and then select the Ethernet **🌐** icon.

CAUTION: Make sure your power source is adequate for the printer voltage rating. The voltage rating is on the printer label. The printer uses 100-127 Vac or 220-240 Vac and 50/60 Hz. To prevent damage to the printer, use only the power cable that is provided with the printer.

FR **3.1** Branchez le cordon d'alimentation entre l'imprimante et une prise secteur mise à la terre. **3.2** Allumez l'imprimante. **3.3** Sur l'écran de Configuration initiale définissez la langue, le lieu, le format de date et d'heure, et d'autres fonctions.

REMARQUE : Pour effectuer une configuration avancée d'imprimantes connectées en réseau, entrez l'adresse IP de l'imprimante dans la barre d'adresse d'un navigateur Web une fois l'imprimante prête. Pour rechercher l'adresse IP, sélectionnez le bouton d'information **i**, puis l'icône Ethernet **🌐**.

ATTENTION : Vérifiez que la source d'alimentation électrique est adéquate pour la tension nominale de l'imprimante. Cette tension nominale est indiquée sur l'étiquette de l'imprimante. L'imprimante utilise 100-127 V (ca) ou 220-240 V (ca) et 50/60 Hz. Afin d'éviter d'endommager l'imprimante, utilisez uniquement le cordon d'alimentation fourni avec l'imprimante.

ES **3.1** Conecte el cable de alimentación a la impresora y a una toma de CA a tierra. **3.2** Encienda la impresora. **3.3** En la pantalla Configuración inicial, establezca el idioma, la ubicación, el formato de fecha y hora y otras funciones.

NOTA: Para realizar una configuración avanzada de las impresoras que se conectan a la red, una vez que la impresora esté en estado preparada, introduzca la dirección IP de la impresora en la barra de direcciones de un navegador web. Para encontrar la dirección IP, seleccione el botón Información **i** y, a continuación, seleccione el icono de Ethernet **🌐**.

PRECAUCIÓN: Asegúrese de que la fuente de alimentación sea la adecuada para el voltaje de la impresora. La información sobre el voltaje se encuentra en la etiqueta de la impresora. La impresora utiliza 100-127 V CA o 220-240 V CA y 50/60 Hz. Para evitar ocasionar daños a la impresora, utilice solo el cable de alimentación que se proporciona con esta.

ADVERTENCIA: Para evitar ocasionar daños en el producto, en áreas en las que se utilice 110 V y 220 V, verifique el voltaje del enchufe.

PT **3.1** Conecte o cabo de alimentação entre a impressora e uma tomada CA aterrada. **3.2** Ligue a impressora. **3.3** Na tela Configuração inicial, defina o idioma, o local e o formato de data/hora, além de outros recursos.

NOTA: Para configuração avançada de impressoras conectadas em rede, digite o endereço IP da impressora na barra de endereço de um navegador da Web depois que a impressora estiver no estado Pronto. Para encontrar o endereço IP, selecione o botão **i** Informações e, depois, o ícone Ethernet **🌐**.

CUIDADO: Verifique se a fonte de alimentação é adequada para a classificação de tensão da impressora. A classificação de tensão está na etiqueta da impressora. A impressora usa 100-127 Vca ou 220-240 Vca e 50/60 Hz. Para evitar danos à impressora, utilize somente o cabo de alimentação fornecido com a impressora.

AVISO: Para impedir ocasionar danos ao produto, em áreas onde 110 V e 220 V estiverem em uso, verifique a tensão da tomada.

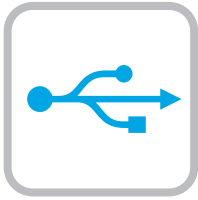

 Windows

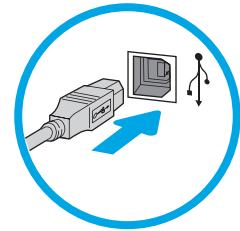
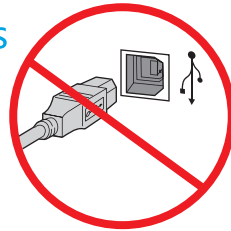

EN

Windows: Do not connect the USB cable until prompted during the software installation in the next step. If the network cable was connected previously, proceed to the next section.

Mac: Connect the USB cable now.

NOTE: The cables are not included with the printer.

ES

Windows: No conecte el cable USB hasta que se le indique durante la instalación del software en el siguiente paso. Si se ha conectado el cable de red anteriormente, vaya a la siguiente sección.

Mac: Conecte ahora el cable USB.

NOTA: Los cables no se incluyen con la impresora.

FR

Windows : Ne branchez pas le câble USB tant que vous n'y êtes pas invité durant l'installation du logiciel à l'étape suivante. Si vous avez précédemment connecté le câble réseau, passez à la section suivante.

Mac : Branchez le câble USB maintenant.

REMARQUE : Les câbles ne sont pas fournis avec l'imprimante.

PT

Windows: não conecte o cabo USB até que seja solicitado a fazê-lo durante a instalação do software na próxima etapa. Se o cabo de rede já tiver sido conectado, prossiga para a próxima seção.

Mac: conecte o cabo USB agora.

NOTA: Os cabos não são fornecidos com a impressora.

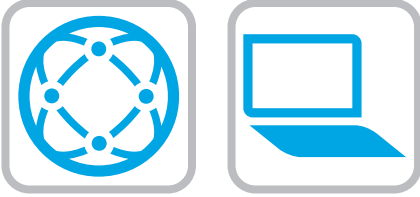

EN

Download the software installation files.

Method 1: Download HP Easy Start (Windows and macOS clients)

1. Go to 123.hp.com and click **Download**.
2. Follow the onscreen instructions.

Method 2: Download from product support website (Windows clients and servers)

1. Go to the product support website: www.hp.com/support/pwcolorE75160 or www.hp.com/support/pwcolorP75250.
2. Select **software and drivers**.
3. Download the software for your printer model and operating system.
4. Launch the software file from the folder where the file was saved, and follow the on-screen instructions.

Method 3: IT managed setup (Windows only - clients and servers)

Visit hp.com/go/upd to download and install the HP Universal Print Driver.

ES

Descargue los archivos de instalación del software.

Método 1: Descarga desde HP Easy Start (Windows y Mac OS)

1. Vaya a 123.hp.com y haga clic en **Descargar**.
2. Siga las instrucciones que se muestran en la pantalla.

Método 2: Descarga desde el sitio web de asistencia del producto (clientes y servidores de Windows)

1. Vaya al sitio web de asistencia del producto: www.hp.com/support/pwcolorE75160 o www.hp.com/support/pwcolorP75250.
2. Seleccione **Software y drivers**.
3. Descargue el software para su modelo de impresora y sistema operativo.
4. Inicie el archivo de software desde la carpeta donde se guardó y, a continuación, siga las instrucciones que aparecen en pantalla.

Método 3: Configuración administrada por TI (únicamente Windows - clientes y servidores)

Visite hp.com/go/upd para descargar e instalar el HP Universal Print Driver.

FR

Téléchargez les fichiers d'installation du logiciel.

Méthode 1 : Téléchargement de HP Easy Start (clients Windows et mac OS)

1. Visitez la page 123.hp.com et cliquez sur **Télécharger**.
2. Suivez les instructions affichées à l'écran.

Méthode 2 : Téléchargement depuis le site Web d'assistance du produit (clients et serveurs Windows)

1. Visitez le site Web d'assistance du produit : www.hp.com/support/pwcolorE75160 ou www.hp.com/support/pwcolorP75250.
2. Sélectionnez **Logiciels et pilotes**.
3. Téléchargez le logiciel adapté à votre modèle d'imprimante et à votre système d'exploitation.
4. Lancez le fichier du logiciel à partir du dossier d'enregistrement du fichier et suivez les instructions affichées à l'écran.

Méthode 3 : Configuration gérée par l'informatique (Windows uniquement - clients et serveurs)

Visitez la page hp.com/go/upd pour télécharger et installer le HP Universal Print Driver (Pilote d'impression universel HP).

PT

Faça download dos arquivos de instalação do software.

Método 1: Faça download do HP Easy Start (clientes Windows e macOS)

1. Acesse 123.hp.com e clique em **Fazer download**.
2. Siga as instruções da tela.

Método 2: Faça download no site de suporte do produto (clientes e servidores do Windows)

1. Acesse o site de suporte do produto: www.hp.com/support/pwcolorE75160 ou www.hp.com/support/pwcolorP75250.
2. Selecione **software e drivers**.
3. Faça o download do software para seu modelo de impressora e sistema operacional.
4. Inicie o arquivo de software da pasta em que ele foi salvo e siga as instruções na tela.

Método 3: Configuração gerenciada de TI (Apenas Windows - clientes e servidores)

Acesse hp.com/go/upd para fazer download do HP Universal Print Driver e instalá-lo.

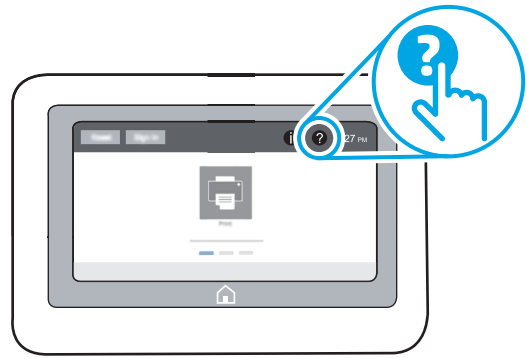

EN For information on firmware updates, advanced configuration using the Embedded Web Server, and remote and mobile printing using HP ePrint go to www.hp.com/support/pwcolorE75160 or www.hp.com/support/pwcolorP75250. Select the Help  button on the printer control panel to access Help topics.

FR Pour obtenir plus d'informations sur les mises à jour de micrologiciels, la configuration avancée à l'aide du serveur Web intégré, ainsi que sur l'impression mobile et à distance à l'aide de HP ePrint, accédez à www.hp.com/support/pwcolorE75160 ou www.hp.com/support/pwcolorP75250. Sélectionnez le bouton  Aide sur le panneau de commandes de l'imprimante pour accéder aux rubriques d'aide.

ES Para obtener información acerca de las actualizaciones de firmware, la configuración avanzada utilizando el servidor web incorporado y la impresión remota y móvil mediante HP ePrint, consulte www.hp.com/support/pwcolorE75160 o www.hp.com/support/pwcolorP75250. Toque el botón de Ayuda  en el panel de control de la impresora para acceder a los temas de ayuda.

PT Para obter informações sobre atualizações do firmware, configuração avançada usando o Embedded Web Server (EWS) e impressão remota e móvel usando o HP ePrint, acesse www.hp.com/support/pwcolorE75160 ou www.hp.com/support/pwcolorP75250. Selecione o botão Ajuda  no painel de controle da impressora para acessar os tópicos da Ajuda.

© Copyright 2020 HP Development Company, L.P.

Reproduction, adaptation or translation without prior written permission is prohibited, except as allowed under the copyright laws.

The information contained herein is subject to change without notice.

The only warranties for HP products and services are set forth in the express warranty statements accompanying such products and services. Nothing herein should be construed as constituting an additional warranty. HP shall not be liable for technical or editorial errors or omissions contained herein.

Trademark Credits

Windows® is a trademark of the Microsoft Group of companies.

macOS is a trademark of Apple Inc., registered in the U.S. and other countries.

AirPrint and the AirPrint logo are trademarks of Apple Inc.



© Copyright 2020 HP Development Company, L.P.

La reproduction, l'adaptation ou la traduction de ce document sans l'autorisation écrite préalable de HP est interdite, sauf dans des conditions conformes aux lois relatives au copyright.

Les informations contenues dans ce document peuvent être modifiées sans préavis.

Les seules garanties pour les produits et services HP sont décrites dans les déclarations de garantie expresse qui accompagnent ces produits et services. Les informations contenues dans ce document ne constituent en aucun cas une garantie supplémentaire. HP n'est pas responsable des erreurs d'ordre technique ou éditorial ou des omissions contenues dans ce document.

Crédits concernant les marques

Windows® est une marque commerciale du groupe de sociétés Microsoft.

macOS est une marque commerciale d'Apple Inc. aux États-Unis et dans d'autres pays/régions.

Le nom et le logo AirPrint sont des marques de commerce d'Apple Inc..



J7Z06-90927

