

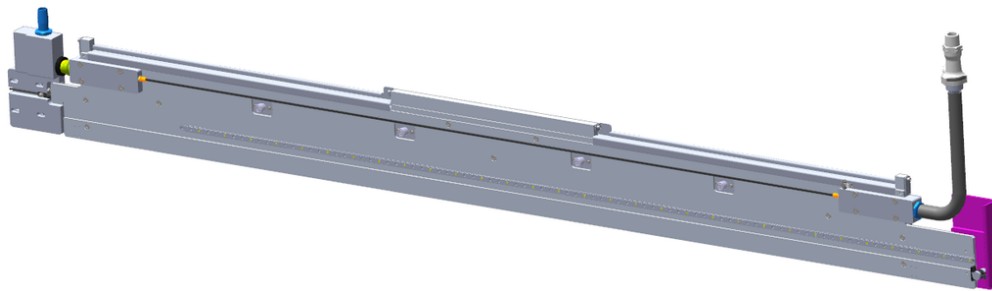

Replacing the Aerosol Cassettes

Service Code:	AER[x]
CSR Level:	CSR B
Part Number:	CX245-06610
Part Name:	AEROSOL CASSETTE
Frequency:	as needed
Document ID:	c05942234
Revision:	Draft 1
Date:	01-May-2018



Required personnel:	1
Required time:	10 minutes
Required tools:	None

Important:

Make sure to comply with all relevant federal, state, and local regulations when disposing of replaced parts.

Procedure

1. Open the print engine service doors on the operator side of the press.
2. Disconnect the vacuum hose coming from the aerosol vacuum pump.

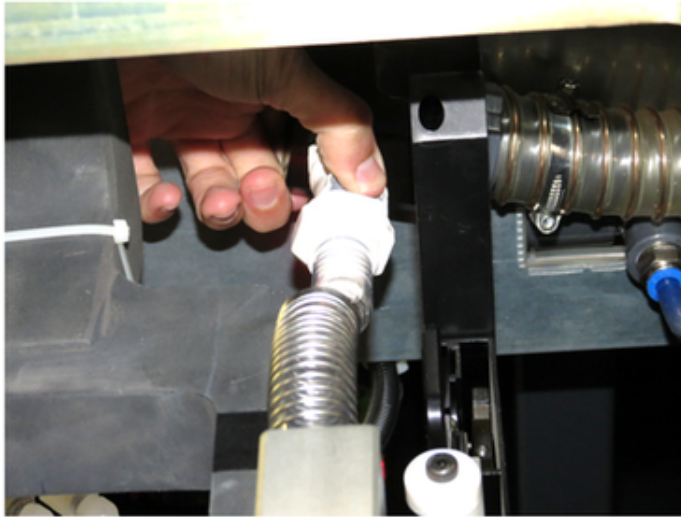

1	Vacuum hose
---	-------------

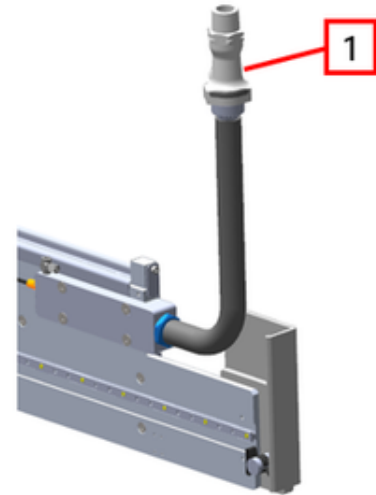

3. Disconnect the water tube.



4. Pull out the aerosol cassette.

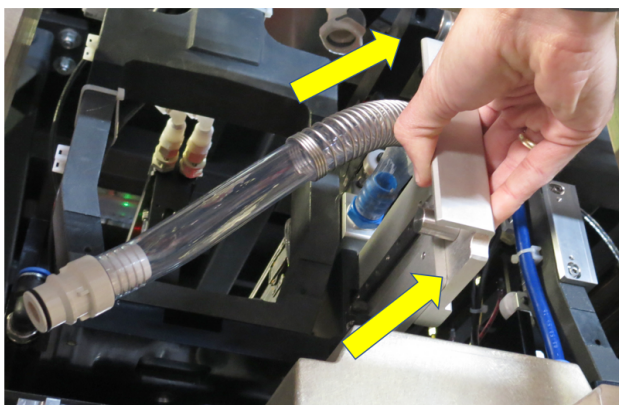

5. Take the new cassette and carefully insert the rail into the bearings on the bridge. Keep inserting until you hear the click.

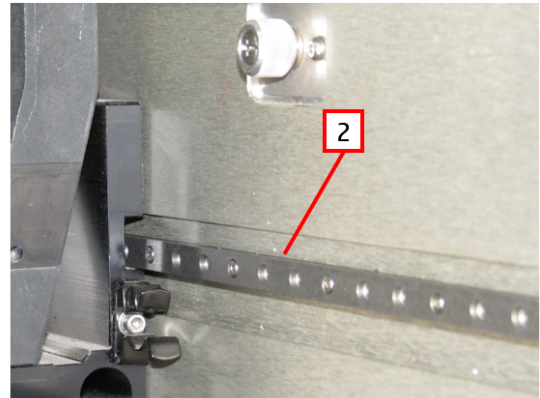
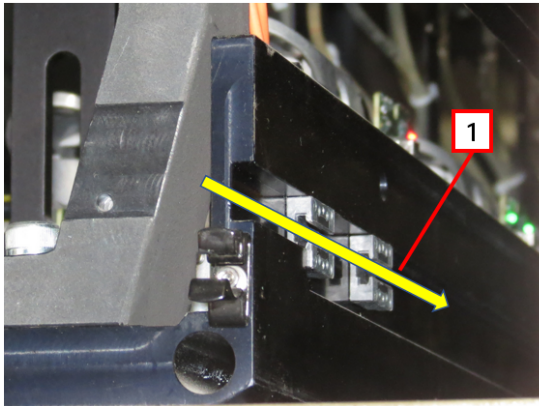

1	Bearings on bridge
2	Cassette rail

Caution:

The space for inserting the aerosol cassette is very narrow. Insert the cassette carefully to prevent possible damage to the capping assembly.

6. Reconnect the water tube.
7. Reconnect the vacuum tube.
8. Close the print engine service doors.