



Replacing an Aerosol Cassette Suction Cup

CSR Level:	CSRB
Part Number:	4320-0836
Part Name:	SUCTION CUP PIGRIP 28MM-D LIP G1/2" MALE
Frequency:	as needed
Document ID:	c05942244
Revision:	Draft 1
Date:	01-May-2018



Required personnel:	1
Required time:	15 minutes
Required tools:	None

Important:

Make sure to comply with all relevant federal, state, and local regulations when disposing of replaced parts.



Procedure

1. Move the printing bridge to the correct position for removing the aerosol cassette.
2. Open the print engine service doors on the operator side of the press.
3. Disconnect the vacuum hose coming from the aerosol vacuum pump.

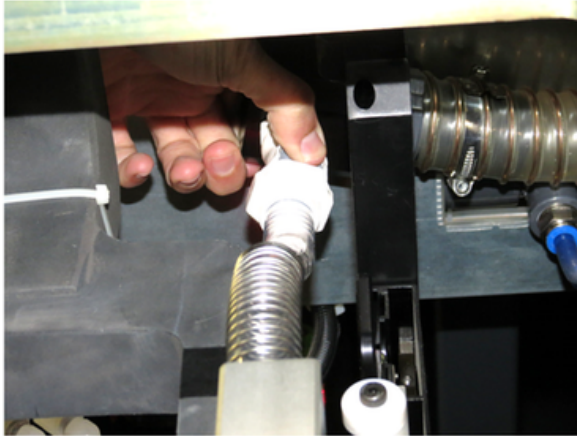

1	Vacuum hose
---	-------------

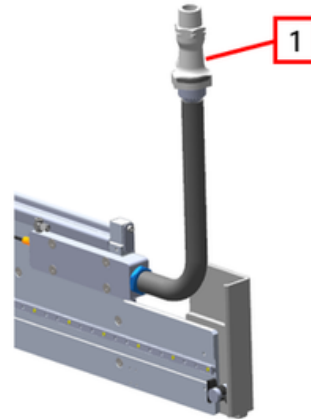

4. Disconnect the water tube.



5. Pull out the aerosol cassette.

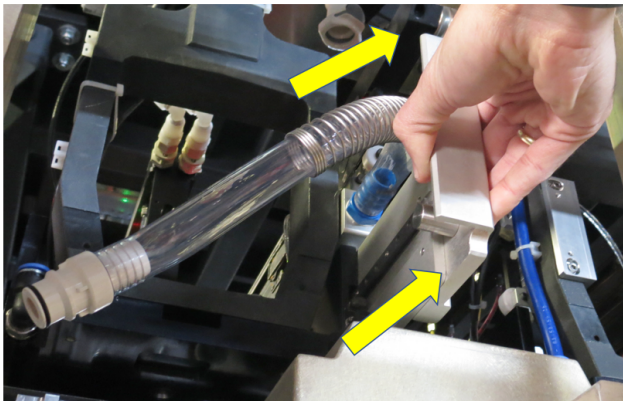

6. Go to the service side of the press and open the sliding doors.
7. Unscrew the suction cup by hand, and remove it from its base.

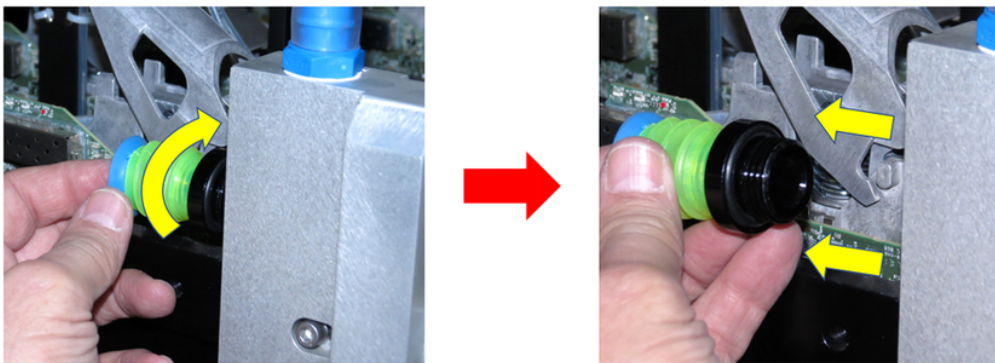

8. Install the new suction cup, tightening it by hand until the suction cup is secure against its base.
9. Close the service side doors.
10. Reinstall the cassette by carefully inserting the rail into the bearings on the bridge. Keep inserting until you hear the click.

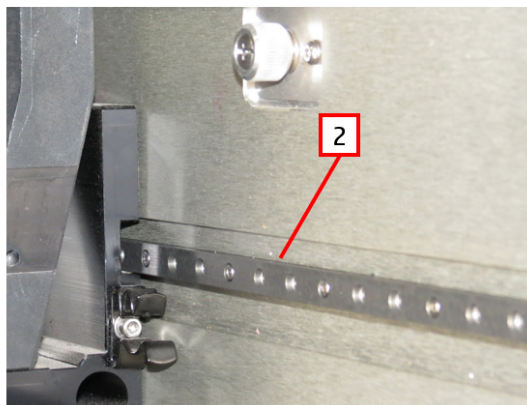
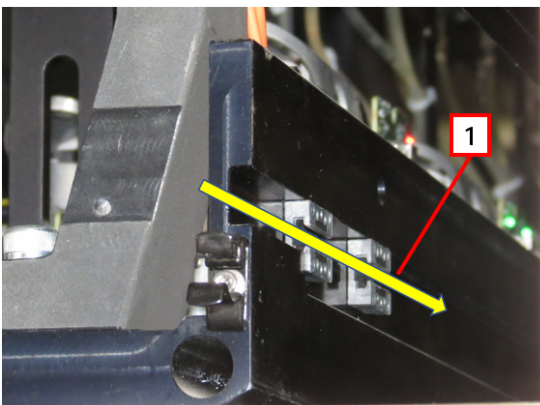

1	Bearings on bridge
2	Cassette rail



Caution:

The space for inserting the aerosol cassette is very narrow. Insert the cassette carefully to prevent possible damage to the capping assembly.

11. Reconnect the water tube.
12. Reconnect the vacuum tube.
13. Close the print engine service doors.