

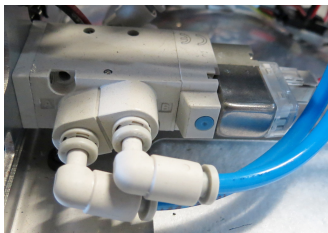

Replacing the Web Wipe Engage Air Valve

Service Code:	MH_WEBWIP[x]_VLV2
CSR Level:	CSR B
Part Number:	CX241-43430
Part Name:	AIR PISTON LOCATOR
Frequency:	as needed
Document ID:	c05942250
Revision:	Draft 1
Date:	27-May-18



Required personnel:	1
Required time:	15 minutes
Required tools:	Allen wrenches

Important:

Make sure to comply with all relevant federal, state, and local regulations when disposing of replaced parts.



Procedure

1. Open the sliding doors on the service side of the print engine.
2. Pull out the web wipe assembly from the print engine.
3. Remove the web wipe cassette.

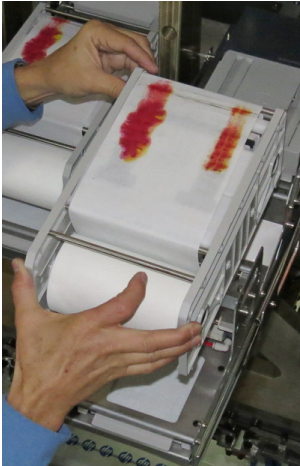

4. Disconnect the tubes and wires connected to the engage valve.

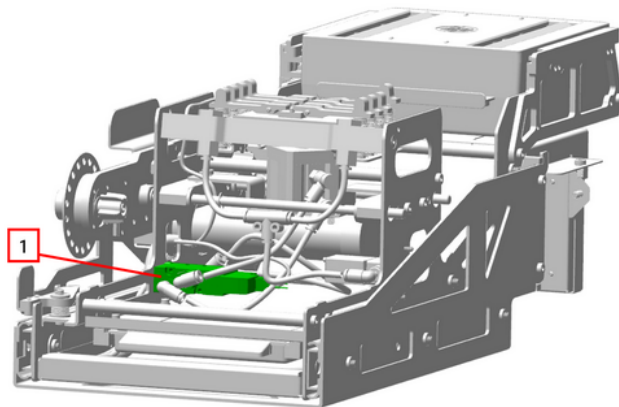

1	Engage valve: MH_WEBWIP[x]_VLV2
---	---------------------------------

5. Using an Allen wrench, remove the engage valve from the assembly.
6. Assemble the new engage valve.
7. Connect the wires and tubes to the new valve.
8. Insert the web wipe cassette.
9. Reinsert the web wipe assembly and close the service doors.