



HP ProBook x360 440 G1 Notebook PC

Maintenance and Service Guide

© Copyright 2018 HP Development Company, L.P.

AMD is a trademark of Advanced Micro Devices, Inc. Bluetooth is a trademark owned by its proprietor and used by HP Inc. under license. Intel is a trademark of Intel Corporation in the U.S. and other countries. Microsoft and Windows are trademarks of the Microsoft group of companies.

The information contained herein is subject to change without notice. The only warranties for HP products and services are set forth in the express warranty statements accompanying such products and services. Nothing herein should be construed as constituting an additional warranty. HP shall not be liable for technical or editorial errors or omissions contained herein.

First Edition: June 2018

Document Part Number: L25622-001

Product notice

This user guide describes features that are common to most models. Some features may not be available on your computer.

Not all features are available in all editions of Windows. This computer may require upgraded and/or separately purchased hardware, drivers and/or software to take full advantage of Windows functionality. Go to <http://www.microsoft.com> for details.

Software terms

By installing, copying, downloading, or otherwise using any software product preinstalled on this computer, you agree to be bound by the terms of the HP End User License Agreement (EULA). If you do not accept these license terms, your sole remedy is to return the entire unused product (hardware and software) within 14 days for a full refund subject to the refund policy of your seller.

For any further information or to request a full refund of the price of the computer, please contact your seller.

Important Notice about Customer Self-Repair Parts

 **CAUTION:** Your computer includes Customer Self-Repair parts and parts that should only be accessed by an authorized service provider. See Chapter 5, "Removal and replacement procedures for Customer Self-Repair parts," for details. Accessing parts described in Chapter 6, "Removal and replacement procedures for Authorized Service Provider only parts," can damage the computer or void your warranty.

Safety warning notice

 **WARNING!** To reduce the possibility of heat-related injuries or of overheating the computer, do not place the computer directly on your lap or obstruct the computer air vents. Use the computer only on a hard, flat surface. Do not allow another hard surface, such as an adjoining optional printer, or a soft surface, such as pillows or rugs or clothing, to block airflow. Also, do not allow the AC adapter to contact the skin or a soft surface, such as pillows or rugs or clothing, during operation. The computer and the AC adapter comply with the user-accessible surface temperature limits defined by the International Standard for Safety of Information Technology Equipment (IEC 60950-1).

Table of contents

1 Product description	1
2 Components	6
Right	6
Left	7
Display	9
Keyboard area	10
TouchPad	10
Lights	11
Speakers and fingerprint reader	12
Special keys	13
Action keys	14
Bottom	15
Labels	16
3 Illustrated parts catalog	18
Computer major components	18
Display components	21
Cable Kit	22
Display Cable Kit	23
Display Rubber Kit	24
Plastics Kit	25
Bracket Kit	25
Miscellaneous parts	26
4 Removal and replacement procedures preliminary requirements	27
Tools required	27
Service considerations	27
Plastic parts	27
Cables and connectors	27
Drive handling	28
Electrostatic discharge damage	28
Packaging and transporting guidelines	29
Workstation guidelines	29
Equipment guidelines	30

5 Removal and replacement procedures for Customer Self-Repair parts	31
Component replacement procedures	31
Battery Safe mode	31
Service doors	32
Memory modules	33
WLAN/Bluetooth combo card	35
WWAN module	37
M.2 solid-state drive	39
Keyboard	40
6 Removal and replacement procedures for Authorized Service Provider parts	43
Component replacement procedures	43
Display subcomponents (panel, cameras, touch control board)	43
Top cover	47
TouchPad assembly	49
Fingerprint reader assembly	50
Battery	52
I/O board	53
RTC battery	54
System board	55
Fan/heat sink assembly	58
Speaker assembly	61
Display assembly	62
Power button board	77
Power connector cable	79
7 Computer Setup (BIOS), TPM, and HP Sure Start	80
Using Computer Setup	80
Starting Computer Setup	80
Using a USB keyboard or USB mouse to start Computer Setup (BIOS)	80
Navigating and selecting in Computer Setup	80
Restoring factory settings in Computer Setup	81
Updating the BIOS	81
Determining the BIOS version	81
Downloading a BIOS update	82
Changing the boot order using the f9 prompt	83
TPM BIOS settings (select products only)	83
Using HP Sure Start (select products only)	83

8 Using HP PC Hardware Diagnostics	84
Using HP PC Hardware Diagnostics Windows (select products only)	84
Downloading HP PC Hardware Diagnostics Windows	84
Downloading the latest HP PC Hardware Diagnostics Windows version	85
Downloading HP Hardware Diagnostics Windows by product name or number (select products only)	85
Installing HP PC Hardware Diagnostics Windows	85
Using HP PC Hardware Diagnostics UEFI	85
Starting HP PC Hardware Diagnostics UEFI	86
Downloading HP PC Hardware Diagnostics UEFI to a USB flash drive	86
Downloading the latest HP PC Hardware Diagnostics UEFI version	86
Downloading HP PC Hardware Diagnostics UEFI by product name or number (select products only)	86
Using Remote HP PC Hardware Diagnostics UEFI settings (select products only)	87
Downloading Remote HP PC Hardware Diagnostics UEFI	87
Downloading the latest Remote HP PC Hardware Diagnostics UEFI version	87
Downloading Remote HP PC Hardware Diagnostics UEFI by product name or number	87
Customizing Remote HP PC Hardware Diagnostics UEFI settings	87
9 Backing up, restoring, and recovering	89
Using Windows tools	89
Creating HP Recovery media (select products only)	89
Using HP Recovery Manager to create recovery media	90
Before you begin	90
Creating the recovery media	90
Using the HP Cloud Recovery Download Tool to create recovery media	91
Restoring and recovery	91
Restoring, resetting, and refreshing using Windows tools	91
Restoring using HP Recovery Manager and the HP Recovery partition	91
Recovering using HP Recovery Manager	91
Recovering using the HP Recovery partition (select products only)	92
Recovering using HP Recovery media	92
Changing the computer boot order	93
Removing the HP Recovery partition (select products only)	93
10 Specifications	94
Computer specifications	94
35.6-cm (14.0-in) display specifications	95
Solid-state drive specifications	96

11 Statement of memory volatility	97
Nonvolatile memory usage	99
Questions and answers	101
Using HP Sure Start (select models only)	102
12 Power cord set requirements	103
Requirements for all countries and regions	103
Requirements for specific countries and regions	103
13 Recycling	105
Index	106

1 Product description

Category	Description
Product Name	HP ProBook x360 440 G1 Notebook PC
Processors	8th generation, Intel® Core™ i7 processor, quad core (8-MB L3 cache, 15 W) i7-8550U, 1.8 GHz/4.0 GHz; Intel UHD Graphics 620
	8th generation, Intel Core i5 processors, quad core (6-MB L3 cache, 15 W) i5-8350U, 1.7 GHz/3.6 GHz; Intel UHD Graphics 620
	i5-8250U, 1.6 GHz/3.4 GHz; Intel UHD Graphics 620
	7th generation, Intel Core i5 processors, dual core (3-MB L3 cache, 15 W) i5-7200U, 2.5-GHz/3.1-GHz; Intel HD Graphics 620
	8th generation, Intel Core i3 processor, dual core (4-MB L3 cache, 15 W) i3-8130U, 2.2-GHz.3.4-GHz; Intel HD Graphics 620
	Intel Pentium dual core processor (2-MB L3 cache, 15 W) 4415U, 2.3-GHz; Intel HD Graphics
	Intel Celeron dual core processor (2-MB L3 cache, 15 W) 3865U, 1.8-GHz; Intel HD Graphics
Graphics	Supports HD decode, DX12, HDMI 1.4b, HDCP 2.2 via HDMI up to 4K@30Hz, DP support 4K@60Hz on 7th/8th Generation Celeron, i3, i5, and i7 processors
	Integrated UMA Graphics GT1 and GT2 Integrated with shared video memory; dynamically allocated
	Switchable discrete graphics NVIDIA® GeForce® MX130 - 2-GB GDDR5 Supports CUDA, Optimus, PhysX, GPU Boost 2.0
Touch module/pen output	Wacom AES Pen with Pen Loop (select models only)
Panel	35.6 cm (14.0-inch), UWVA, FHD (1920×1080), eDP, IPS, slim (3.0 mm), touch HD camera, 220 nits, 45% CG IR camera, 220 nits, 45% CG HD camera with WWAN, 220 nits, 45% CG IR camera with WWAN, 220 nits, 45% CG IR camera with WWAN, eDP+PSR, 400 nits, 72% CG
Memory	Two customer-accessible memory module slots supporting up to 32 GB of RAM Supports dual-channel memory

Category	Description
	<p>PC4, 2133-MHz, DDR4 SODIMMs (models with 8th generation Intel Core processors run at 2400 MHz)</p> <p>Supports the following configurations:</p> <ul style="list-style-type: none"> • 32768 MB (16384 × 2; dual channel) • 16384 MB (16384 × 1) • 16384 MB (8192 × 2; dual channel) • 12288 MB (8192 + 4096; dual channel) • 8192 MB (8192 × 1) • 8192 MB (4096 × 2; dual channel) • 4096 MB (4096 × 1)
Primary M.2 storage	<p>M.2 2280 SSD (NGFF)</p> <ul style="list-style-type: none"> • 512 GB, PCIe, NVMe, TLC (not available with Celeron) • 256 GB, PCIe, NVMe, value (not available with Celeron) • 256 GB, SATA, TLC • 128 GB, SATA, TLC
Audio/Visual	<p>Audio controls</p> <p>Integrated dual-array microphone</p> <p>Integrated camera (720p HD) (supports Wide Dynamic Range [WDR])</p> <p>IR camera (720p HD) (supports WDR)</p> <p>Stereo speakers (2)</p> <p>Headphone/microphone combo jack</p>
Ethernet	<p>Realtek RTL8111HSH-CG 10/100/1000</p> <p>S3/S4/S5 wake on LAN (AC mode and battery mode)</p> <p>The following support S3/S4/S5 wake on LAN: embedded NIC</p> <p>The following support S3/S4/S5 wake on LAN/HBMA (via out of band): HP Elite USB-C Dock G3, HP USB-C Dock G4, HP USB-C Universal Dock, HP Thunderbolt Dock 120W G2, and HP USB-C Mini Dock</p>
Wireless	<p>Integrated WLAN options by way of wireless module (select models only)</p> <p>Support WiFi SAR (enabled in BIOS)</p> <p>Supports HP Connection Optimizer with wi-fi load balancing</p> <p>Supports the following wireless adapters via minicard connector:</p> <ul style="list-style-type: none"> • Realtek RTL8822BE 802.11AC 2x2 Wi-Fi + Bluetooth 4.2 Combination Adapter • Intel Dual Band Wireless-AC 8265, 802.11ac, 2×2 Wi-Fi + Bluetooth 4.2 Combination Adapter (non-vPro) <p>Wireless Personal Area Network (PAN) Bluetooth</p> <p>Bluetooth 4.2 supported using combo card</p> <p>Integrated WWAN options by way of wireless module (select models only)</p>

Category	Description
	<p>SIM module: Micro SIM/3FF (user accessible under service door)</p> <p>WWAN cards are compatible with a programmable removable eSIM</p> <p>Integrated WWAN options with dual antennas (M.2 30×42 socket USB2):</p> <ul style="list-style-type: none"> • Huawei HP It4132, LTE/HSPA+ w/GPS M.2 • Fibocom CAT9: Intel XMM™ 7360 LTE-Advanced
External media card	<p>Digital Media Reader Slot</p> <p>Supports SDXC</p>
Ports (Input/output)	<p>USB 3.0 + powered port (left)</p> <p>USB 3.0 port (right)</p> <p>USB Type-C (PD+DP, USB 3.1 Gen 1, right)</p> <p>HDMI 1.4b (right)</p> <p>Headphone/microphone combo jack (left)</p> <p>RJ-45 (Ethernet, right)</p> <p>Multi-pin AC port (right)</p>
Docking	Docking via USB Type-C
Keyboard/pointing devices	<p>Keyboard</p> <p>HP Premium Keyboard</p> <p>TouchPad</p> <p>Full-sized, chiclet, spill-resistant keyboard (backlit or not backlit)</p> <p>TouchPad requirements</p> <p>Taps enabled by default</p> <p>On/off control by driver</p> <p>Supports PTP with Miniport driver</p> <p>Windows 10 gestures enabled by default: 2-finger scrolling and zoom enabled by default, OSD (enable/disable), 3-finger tap - Cortana, 3-finger flick - App switch, 4-finger tap - Action Center</p> <p>Windows 10 gestures disabled by default: 3-finger flick, 2-finger rotate, momentum motion, 1-finger vertical scroll</p>
Power requirements	<p>Battery</p> <p>3-cell prismatic, 48-Wh, long-life, Li-ion battery</p> <p>Supports HP Fast Charge technology: 90% in 90 minutes under S3/S4/S5</p> <p>AC adapters</p> <p>65-W Smart AC adapter, right angle, 4.5 mm (discrete only)</p> <p>65-W Smart AC adapter, right angle, 4.5 mm – EM (discrete only)</p> <p>65-W, straight AC adapter, USB Type-C</p> <p>45-W Smart AC adapter, right angle, 4.5 mm (UMA only)</p>

Category	Description
	45-W Smart AC adapter, right angle, 4.5 mm (UMA only) – Argentina
	45-W, straight AC adapter, USB Type-C
	Power cords
	3-wire plug, 1.8 m
	3-wire plug, 1.0 m
	Duckhead power cord (C5NS), 1.8 m, premium (only available with USB Type-C AC adapters)
	Duckhead power cord (C5NS), 1.0 m, premium (only available with USB Type-C AC adapters)
	Duckhead power cord (C5NS)
Security	Kensington Universal Security Slot - Micro Saver
	Integrated fingerprint reader (select models only)
	TPM 2.0 SLB9670 (Infineon; soldered down)
	Hardware enforced firmware protection: HP Hardware Root of Trust
	ANSSI Certified Hardware Root of Trust: Yes
Operating system	Operating system version
	Windows 10
	Preinstalled
	Windows 10 Home 64
	Windows 10 Home 64 – Plus
	Windows 10 Home 64 Single Language
	Windows 10 Home 64 Single Language – Plus
	Windows 10 Home 64 Chinese Market - CPPP
	Windows 10 Home 64 High-end Chinese Market - CPPP
	Windows 10 Home 64 StF MSNA for Higher Education
	Windows 10 Home 64 StF MSNA for Higher Education - Strategic
	Windows 10 Professional 64
	Windows 10 Professional StF MSNA
	Windows 10 Professional StF MSNA EM
	Windows 10 Professional 64 StF MSNA - Standard
	Windows 10 Professional 64 StF MSNA - Plus
	Windows 10 Professional StF MSNA - Strategic
	FreeDOS 2.0
	Restore Media (DRDVD/SRDVD)
	DRDVD Windows 10
	Restore Media (OSDVD)





Category	Description
	Windows 10 Professional 64
	Certified
	Microsoft WHQL
	Web-only support
	Windows 10 Enterprise
	Windows 10 Enterprise 64 LTSB 1607
Serviceability	End-user replaceable parts
	AC adapter
	M.2 solid-state drive
	Memory module
	WLAN module
	WWAN module
	WWAN SIM card
	Keyboard

2 Components

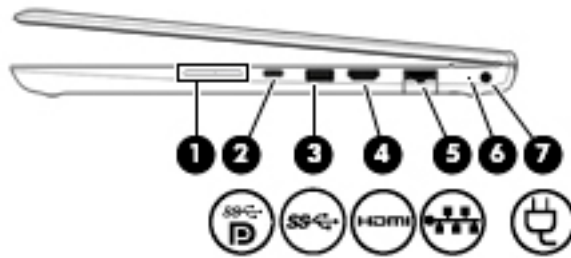
Your computer features top-rated components. This chapter provides details about your components, where they're located, and how they work.

Right







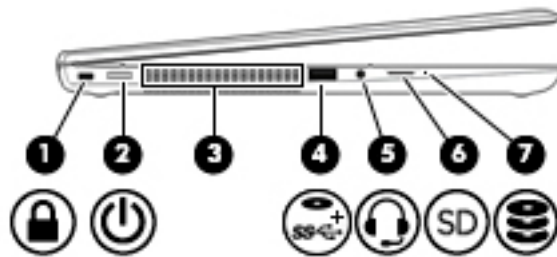

Component	Description
(1)	Volume button Controls speaker volume on the computer.
(2) 	USB Type-C SuperSpeed port and DisplayPort When the computer is on, connects and charges most USB devices that have a Type-C connector, such as a cell phone, camera, activity tracker, or smartwatch, and provides high-speed data transfer. NOTE: Cables and/or adapters (purchased separately) may be required. – and – Connects a DisplayPort device that has a USB Type-C connector, providing display output.
(3) 	USB SuperSpeed port Connects a USB device, such as a cell phone, camera, activity tracker, or smartwatch, and provides high-speed data transfer.
(4) 	HDMI port Connects an optional video or audio device, such as a high-definition television, any compatible digital or audio component, or a high-speed High Definition Multimedia Interface (HDMI) device.
(5) 	RJ-45 (network) jack/status lights Connects a network cable. <ul style="list-style-type: none"> Green (right): The network is connected. Amber (left): Activity is occurring on the network.
(6)	Battery light When AC power is connected: <ul style="list-style-type: none"> White: The battery charge is greater than 90 percent. Amber: The battery charge is from 0 to 90 percent. Off: The battery is not charging. When AC power is disconnected (battery not charging):

Component	Description
	<ul style="list-style-type: none"> Blinking amber: The battery has reached a low battery level. When the battery has reached a critical battery level, the battery light begins blinking rapidly. Off: The battery is not charging.
(7) 	Power connector Connects an AC adapter.

Left



Component	Description
(1) 	Security cable slot Attaches an optional security cable to the computer. NOTE: The security cable is designed to act as a deterrent, but it may not prevent the computer from being mishandled or stolen.
(2) 	Power button <ul style="list-style-type: none"> When the computer is off, press the button to turn on the computer. When the computer is on, press the button briefly to initiate Sleep. When the computer is in the Sleep state, press the button briefly to exit Sleep. When the computer is in Hibernation, press the button briefly to exit Hibernation. CAUTION: Pressing and holding down the power button results in the loss of unsaved information. If the computer has stopped responding and shutdown procedures are ineffective, press and hold the power button for at least 5 seconds to turn off the computer. To learn more about your power settings, see your power options. ▲ Right-click the Power meter icon  and then select Power Options .
(3)	Vent Enables airflow to cool internal components. NOTE: The computer fan starts up automatically to cool internal components and prevent overheating. It is normal for the internal fan to cycle on and off during routine operation.

Component	Description
(4)  USB SuperSpeed powered port	Connects and supplies power to a USB device, such as a cell phone, camera, activity tracker, optical drive, or smartwatch, and provides high-speed data transfer.
(5)  Audio-out (headphone)/Audio-in (microphone) combo jack	Connects optional powered stereo speakers, headphones, earbuds, a headset, or a television audio cable. Also connects an optional headset microphone. This jack does not support optional standalone microphones. <p>WARNING! To reduce the risk of personal injury, adjust the volume before putting on headphones, earbuds, or a headset. For additional safety information, refer to the <i>Regulatory, Safety, and Environmental Notices</i>.</p> To access this guide: <ul style="list-style-type: none"> ▲ Select the Start button, select HP Help and Support, and then select HP Documentation. – or – <ul style="list-style-type: none"> ▲ Select the Start button, select HP, and then select HP Documentation. <p>NOTE: When a device is connected to the jack, the computer speakers are disabled.</p>
(6)  MicroSD memory card reader	Reads optional memory cards that store, manage, share, or access information. <p>To insert a card:</p> <ol style="list-style-type: none"> 1. Hold the card label-side up, with the connectors facing the computer. 2. Insert the card into the memory card reader, and then press in on the card until it is firmly seated. <p>To remove a card:</p> <ul style="list-style-type: none"> ▲ Press in on the card, and then remove it from the memory card reader.
(7)  Drive light	<ul style="list-style-type: none"> • Blinking white: The hard drive is being accessed. • Amber: HP 3D DriveGuard has temporarily parked the hard drive.

Display



Component	Description
(1) WLAN antennas* (select products only)	Send and receive wireless signals to communicate with wireless local area networks (WLANs).
(2) WWAN antennas* (select products only)	Send and receive wireless signals to communicate with wireless wide area networks (WWANs).
(3) Camera(s)	Allow(s) you to video chat, record video, and record still images. Some cameras also allow a facial recognition logon to Windows, instead of a password logon. NOTE: Camera functions vary depending on the camera hardware and software installed on your product.
(4) Internal microphones	Record sound.
(5) Camera light	On: The camera(s) are in use.

*The antennas are not visible from the outside of the computer. For optimal transmission, keep the areas immediately around the antennas free from obstructions.

For wireless regulatory notices, see the section of the *Regulatory, Safety, and Environmental Notices* that applies to your country or region.

To access this guide:

▲ Select the **Start** button, select **HP Help and Support**, and then select **HP Documentation**.

– or –

▲ Select the **Start** button, select **HP**, and then select **HP Documentation**.

Keyboard area



TouchPad

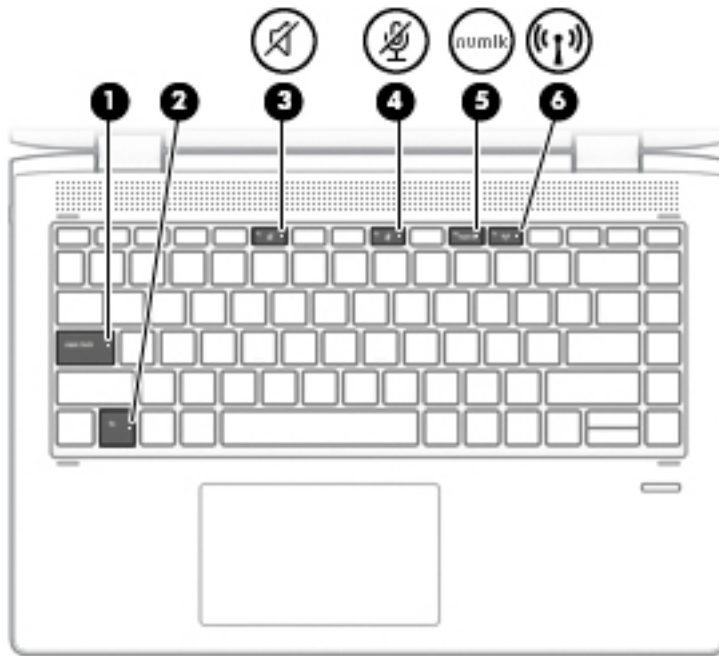

Component		Description
(1)	TouchPad zone	Reads your finger gestures to move the pointer or activate items on the screen.
(2)	Left control zone	Textured area that allows you to perform additional gestures.
(3)	Right control zone	Textured area that allows you to perform additional gestures.

Lights



Component	Description
(1) Caps lock light	On: Caps lock is on, which switches the key input to all capital letters.
(2) Fn lock light	On: The fn key is locked.
(3)  Mute light	<ul style="list-style-type: none"> On: Computer sound is off. Off: Computer sound is on.
(4)  Microphone mute light	<ul style="list-style-type: none"> On: Microphone is off. Off: Microphone is on.
(5) numlk Num lk light	On: Num lock is on.
(6)  Wireless light	On: An integrated wireless device, such as a wireless local area network (WLAN) device and/or a Bluetooth® device, is on.
	NOTE: On some models, the wireless light is amber when all wireless devices are off.

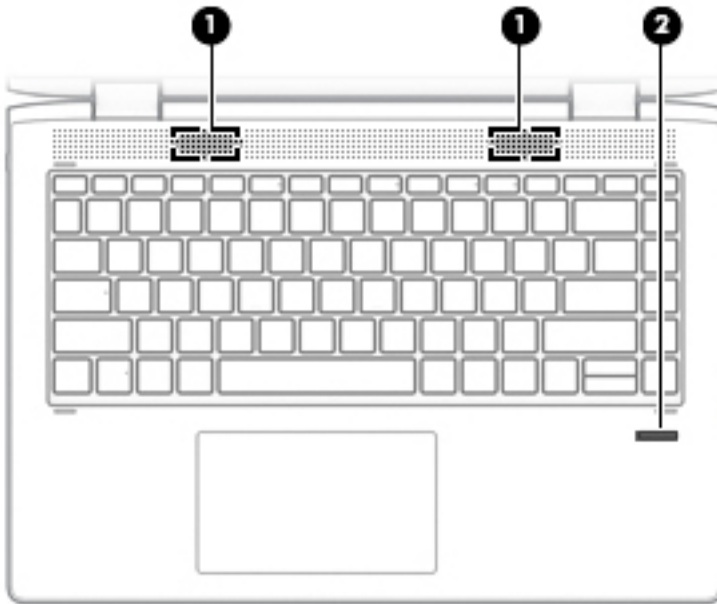

Speakers and fingerprint reader

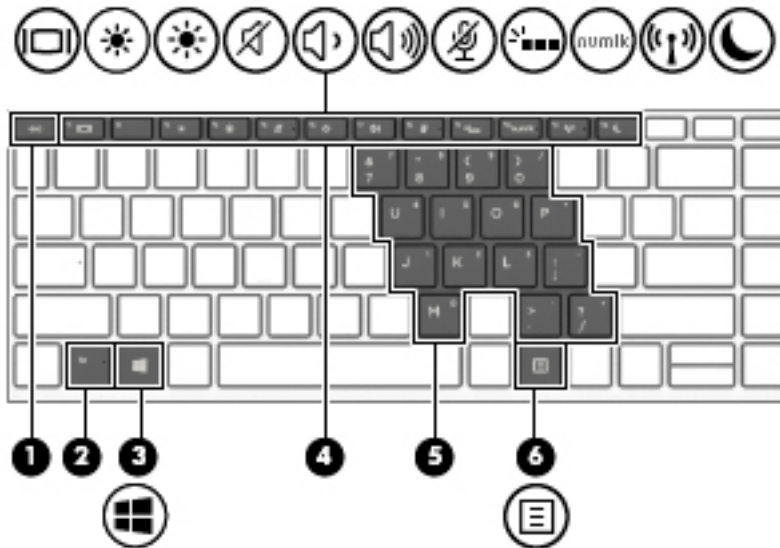

Component	Description
(1) Speakers (2)	Produce sound.
(2) Fingerprint reader (select products only)	Allows a fingerprint logon to Windows, instead of a password logon.

Special keys













Component	Description
(1) esc key	Displays system information when pressed in combination with the fn key.
(2) fn key	Executes frequently used system functions when pressed in combination with another key. Such key combinations are called <i>hot keys</i> .
(3)  Windows key	Opens the Start menu. NOTE: Pressing the Windows key again will close the Start menu.
(4) Action keys	Execute frequently used system functions. See Action keys on page 14 .
(5) Embedded numeric keypad	A numeric keypad superimposed over the keyboard alphabet keys. When num lk is pressed, the keypad can be used like an external numeric keypad. Each key on the keypad performs the function indicated by the icon in the upper-right corner of the key. NOTE: If the keypad function is active when the computer is turned off, that function is reinstated when the computer is turned back on.
(6)  Windows application key	Displays options for a selected object.

Action keys

An action key performs the function indicated by the icon on the key. To determine which keys are on your product, see [Special keys on page 13](#).

▲ To use an action key, press and hold the key.

Icon	Description
	Switches the screen image among display devices connected to the system. For example, if a monitor is connected to the computer, repeatedly pressing the key alternates the screen image from computer display to monitor display to simultaneous display on both the computer and the monitor.
	Decreases the screen brightness incrementally as long as you hold down the key.
	Increases the screen brightness incrementally as long as you hold down the key.
	Mutes or restores speaker sound.
	Decreases speaker volume incrementally while you hold down the key.
	Increases speaker volume incrementally while you hold down the key.
	Mutes the microphone.
	Turns the keyboard backlight off or on. NOTE: To conserve battery power, turn off this feature.
num lk	Turns the embedded numeric keypad on and off.
	Turns the wireless feature on or off. NOTE: A wireless network must be set up before a wireless connection is possible.
	Initiates Sleep, which saves your information in system memory. The display and other system components turn off and power is conserved. To exit Sleep, briefly press the power button. CAUTION: To reduce the risk of information loss, save your work before initiating Sleep.

 **NOTE:** The action key feature is enabled at the factory. You can disable this feature by pressing and holding the **fn** key and the left **shift** key. The **fn** lock light will turn on. After you have disabled the action key feature, you can still perform each function by pressing the **fn** key in combination with the appropriate action key.

Bottom

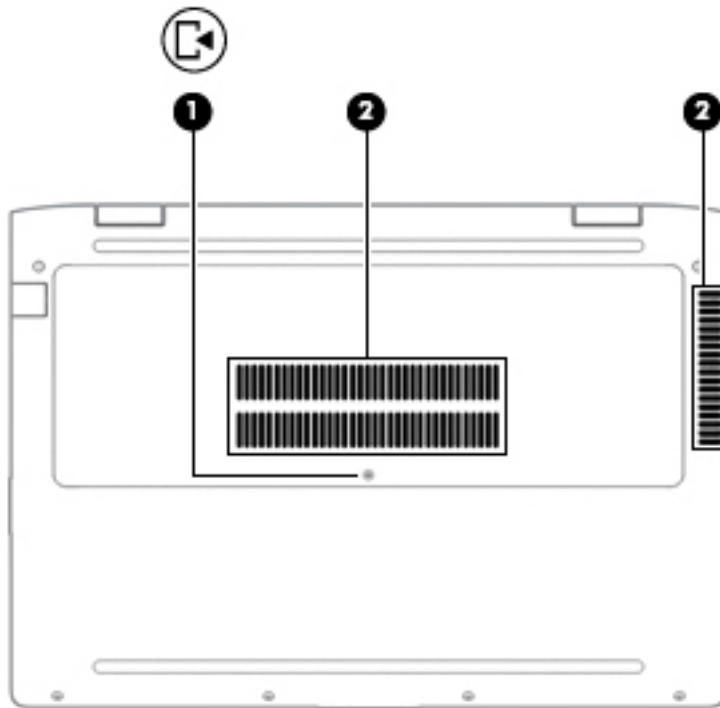

Component	Description
(1) 	Service door release latch Releases the service door.
(2)	Vents (2) Enable airflow to cool internal components. NOTE: The computer fan starts up automatically to cool internal components and prevent overheating. It is normal for the internal fan to cycle on and off during routine operation.

Labels

The labels affixed to the computer provide information you may need when you troubleshoot system problems or travel internationally with the computer. Labels may be in paper form or imprinted on the product.

 **IMPORTANT:** Check the following locations for the labels described in this section: the bottom of the computer, inside the battery bay, under the service door, on the back of the display, or on the bottom of a tablet kickstand.

- Service label—Provides important information to identify your computer. When contacting support, you may be asked for the serial number, the product number, or the model number. Locate this information before you contact support.

Your service label will resemble one of the examples shown below. Refer to the illustration that most closely matches the service label on your computer.

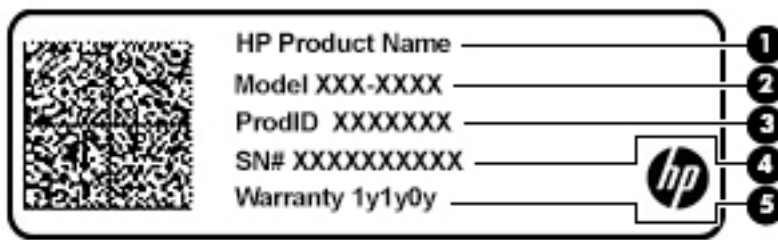

Component

- (1) HP product name
- (2) Model number
- (3) Product ID
- (4) Serial number
- (5) Warranty period

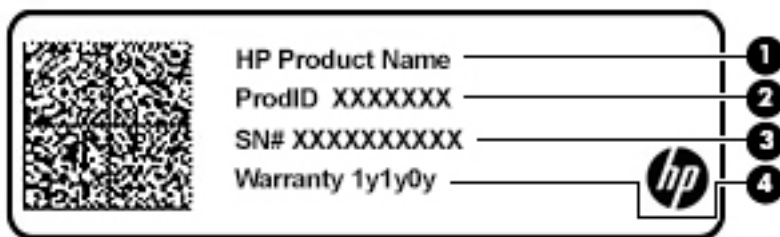

Component

- (1) HP product name
- (2) Product ID

Component

(3) Serial number

(4) Warranty period

- Regulatory label(s)—Provide(s) regulatory information about the computer.
- Wireless certification label(s)—Provide(s) information about optional wireless devices and the approval markings for the countries or regions in which the devices have been approved for use.

3 Illustrated parts catalog

Computer major components

 **NOTE:** HP continually improves and changes product parts. For complete and current information on supported parts for your computer, go to <http://partsurfer.hp.com>, select your country or region, and then follow the on-screen instructions.

 **NOTE:** Details about your computer, including model, serial number, product key, and length of warranty, are on the service tag at the bottom of your computer. See [Labels on page 16](#) for details.

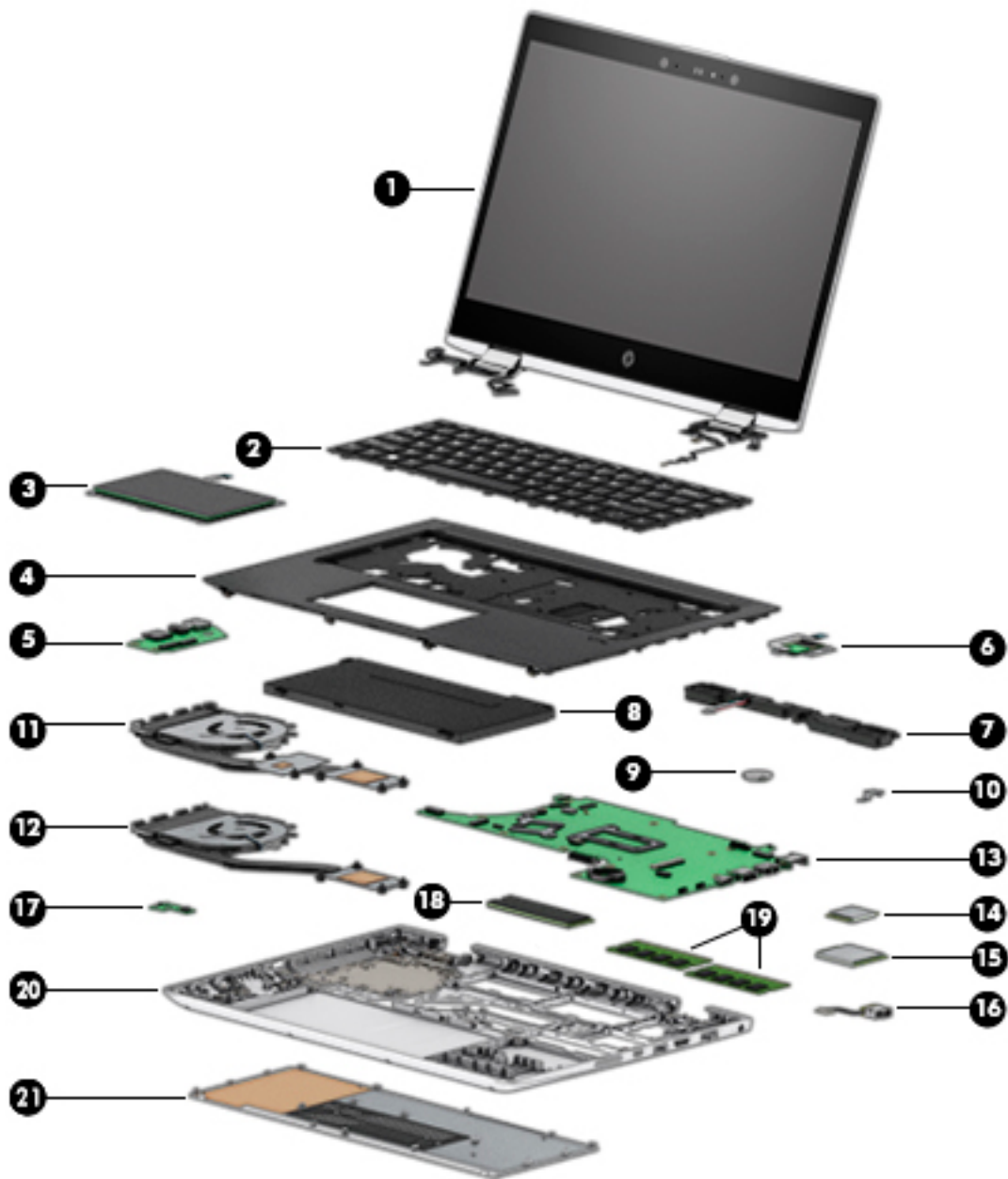

Item	Description	Spare part number
(1)	Display panel assembly , touch screen NOTE: Displays are spared only at the subcomponent level.	
(2)	Keyboard (includes cable) NOTE: For a detailed list of keyboard country codes, see Keyboard on page 40 .	
	No backlight	L28408-xxx
	Backlit	L28406-xxx
(3)	TouchPad	L28253-001
(4)	Top cover	
	For use in models with UMA graphics memory	L28268-001
	For use in models with discrete graphics memory	L28269-001
(5)	I/O board	L28252-001
(6)	Fingerprint reader assembly	L28254-001
(7)	Speaker assembly	L28271-001
(8)	Battery, Li-ion (4-cell, 48 WHr, 4.21 Ah)	L12791-855
(9)	RTC battery	not spared
(10)	USB-C bracket	L29057-001 (Bracket Kit)
	Fan/heat sink assembly (includes replacement thermal material)	
(11)	Models with discrete graphics	L28267-001
(12)	Models with UMA graphics	L28266-001
(13)	System board (includes replacement thermal material) All system boards use the following part numbers: xxxxxx-001: Non-Windows operating system xxxxxx-601: Windows 10 operating system	
	Models with UMA graphics:	
	• Intel Core i7-8550U processor	L28242-xxx
	• Intel Core i5-8350U processor	L35766-xxx
	• Intel Core i5-8250U processor (WWAN models)	L28244-xxx
	• Intel Core i5-8250U processor	L28241-xxx
	• Intel Core i3-8130U processor (WWAN models)	L28243-xxx
	• Intel Core i3-8130U processor	L28239-xxx
	• Intel Core i5-7200U processor	L28240-xxx
	• Intel Pentium 4415U processor	L31173-xxx
	• Intel Celeron 3865U processor	L28238-xxx
	Models with discrete graphics:	

Item	Description	Spare part number
	<ul style="list-style-type: none"> Intel Core i7-8550U processor 	L28248-xxx
	<ul style="list-style-type: none"> Intel Core i5-8250U processor 	L28247-xxx
	<ul style="list-style-type: none"> Intel Core i3-8130U processor 	L28245-xxx
	<ul style="list-style-type: none"> Intel Core i5-7200U processor 	L28246-xxx
(14)	WLAN module	
	Intel Dual Band Wireless-AC 8265, 802.11ac, 2x2 Wi-Fi + Bluetooth 4.2 combination adapter	851594-001
	Realtek RTL8822BE 802.11AC 2x2 Wi-Fi + Bluetooth 4.2 combination adapter	915623-001
(15)	WWAN module	
	Huawei HP It4132, LTE/HSPA+ w/GPS M.2	845710-001
	Intel XMM 7360 LTE-Advanced	917823-001
(16)	Power connector cable	L28264-001
(17)	Power button board	L28251-001
(18)	M.2 solid-state drive	
	512-GB, PCIe, TLC	L28275-001
	256-GB, PCIe	L28274-001
	256-GB, SATA-3, TLC	L33505-001
	128-GB, SATA-3	L28273-001
(19)	Memory modules	
	16-GB (DDR4-2400)	865396-855
	8-GB (DDR4-2400)	862398-855
	4-GB (DDR4-2133)	820569-005
(20)	Base enclosure	L28262-001
(21)	Service door	
	UMA models	L29058-001
	Discrete models	L34117-001

Display components

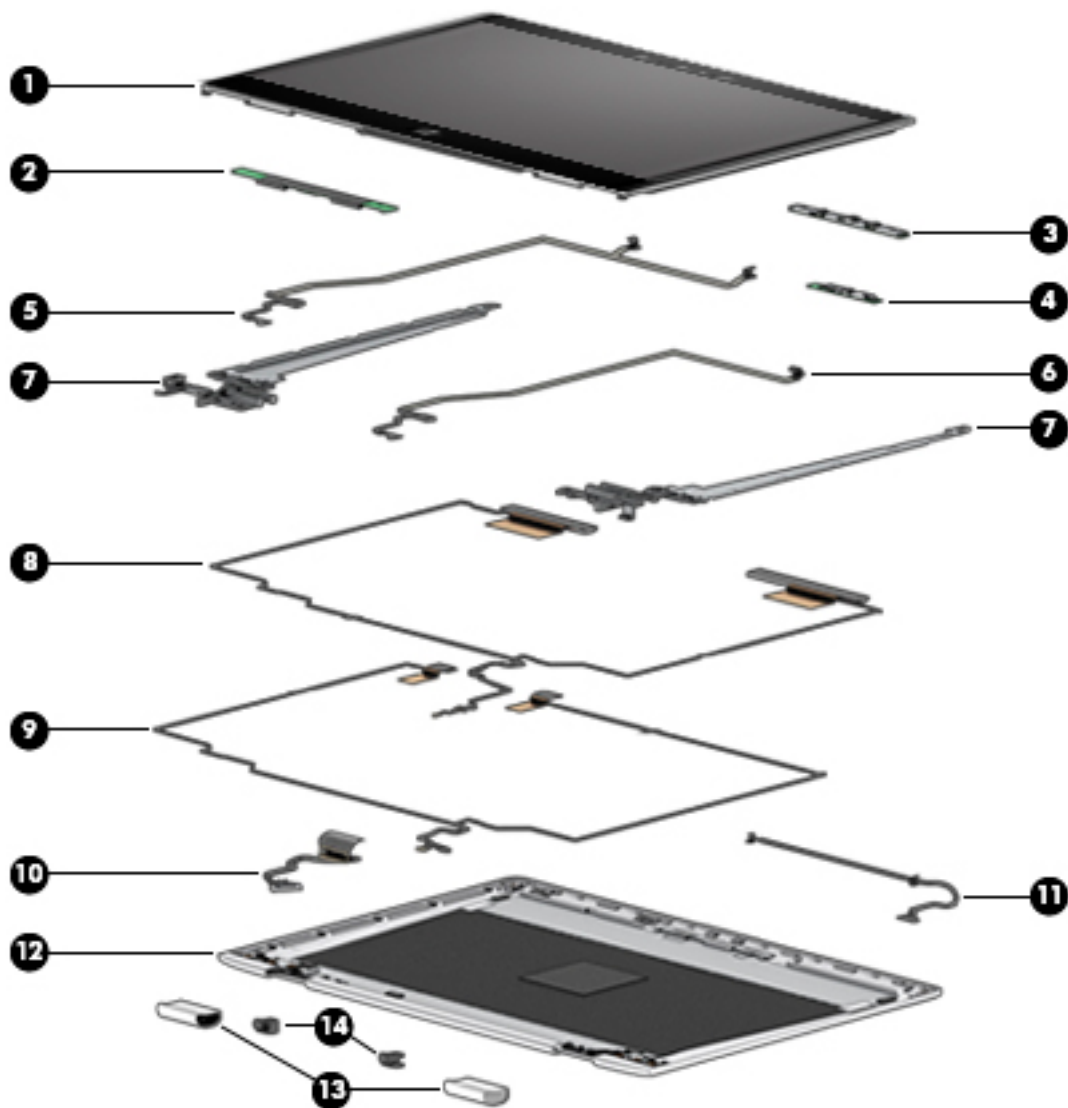

Item	Description	Spare part number
(1)	Display panel kit (includes display panel, magnets, bezel, eDP cable)	
	HD camera	L28255-001
	HD+IR camera	L28256-001
	HD camera, coaxial	L28257-001
	HD+IR camera, coaxial	L28258-001
	HD+IR camera on WWA models	L28259-001
(2)	Touch controller board (includes adhesive kit)	L29890-001
(3)	IR camera module (includes bezel adhesive)	L28260-001
(4)	HD camera module (includes bezel adhesive)	L28261-001

Item	Description	Spare part number
(5)	IR camera cable	L31774-001 (Display Cable Kit)
(6)	HD camera cable	L31774-001 (Display Cable Kit)
(7)	Hinge Kit (includes left and right hinges and display adhesive kit)	L28250-001
(8)	WWAN antennas (includes adhesive kit)	L29055-001
(9)	WLAN antennas (includes adhesive kit)	L29054-001
(10)	eDP cable	L31774-001 (Display Cable Kit)
(11)	Display cable	L31174-001 (Display Cable Kit)
(12)	Display rear cover (includes bezel adhesive)	L28249-001
(13)	Hinge covers, left and right (includes adhesive kit)	L29056-001
(14)	Rubber antenna guide	L31775-001 (Display Rubber Kit)

Cable Kit

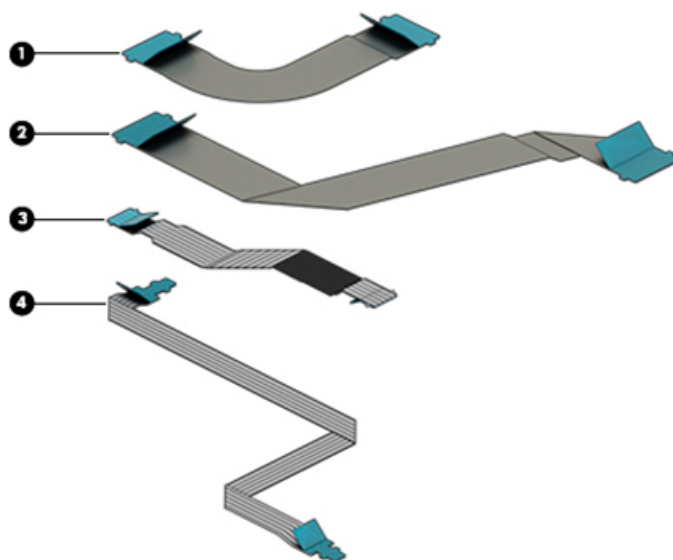

Item	Description	Spare part number
	Cable Kit , includes the following parts:	L28263-001
(1)	I/O board cable	
(2)	I/O board cable	
(3)	TouchPad cable	
(4)	Power button board cable	

Display Cable Kit

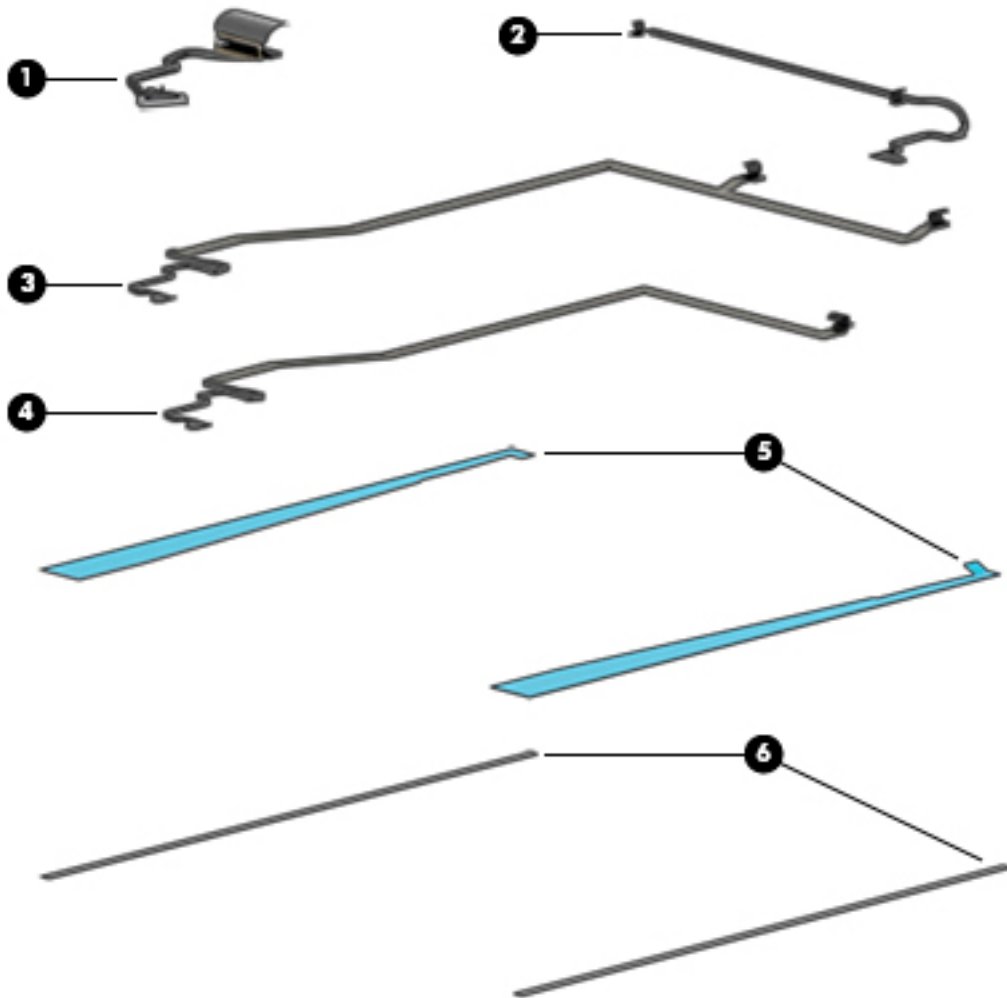

Item	Description	Spare part number
	Display Cable Kit , includes the following parts:	L31174-001
(1)	EDP cable	
	EDP coaxial cable	
(2)	Touch cable	
(3)	IR camera cable	
(4)	HD camera cable	
(5)	Right and left hinge adhesive	
(6)	Right and left bezel adhesive	

Display Rubber Kit

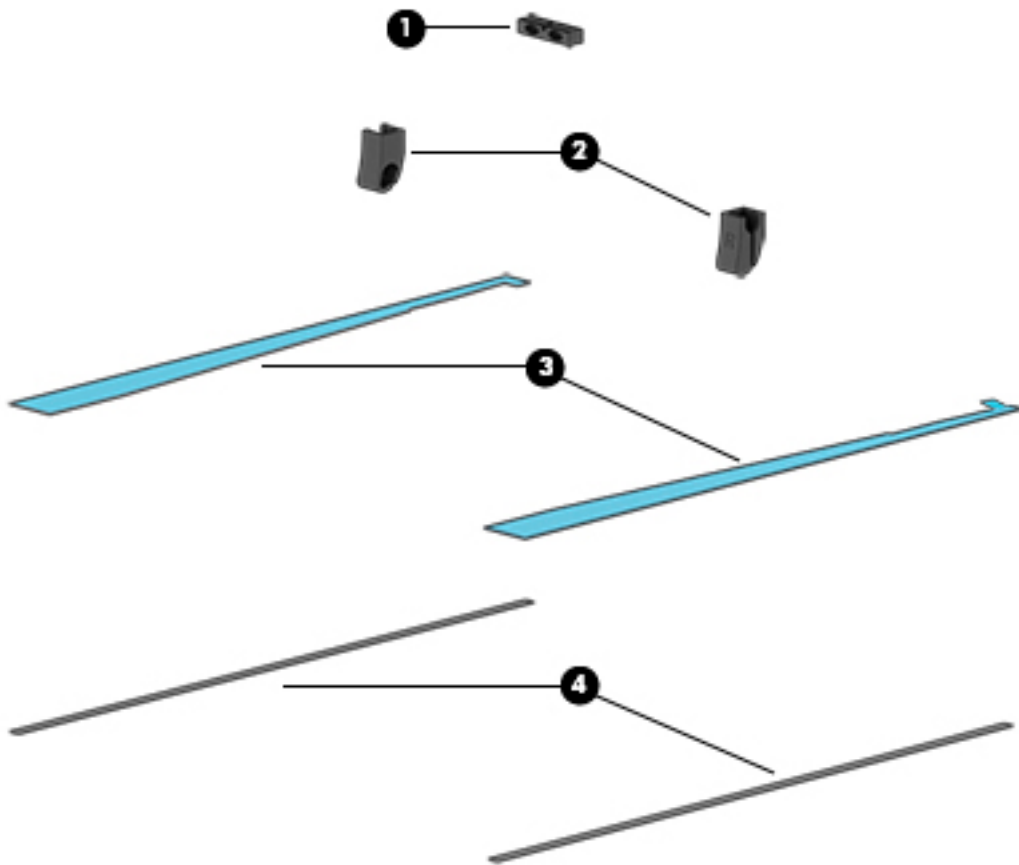

Item	Description	Spare part number
	Display Rubber Kit , includes the following parts:	L31175-001
(1)	Antenna cable rubber guide	
(2)	Left and righer rubber hinge caps	
(3)	Right and left hinge adhesive	
(4)	Right and left bezel adhesive	

Plastics Kit

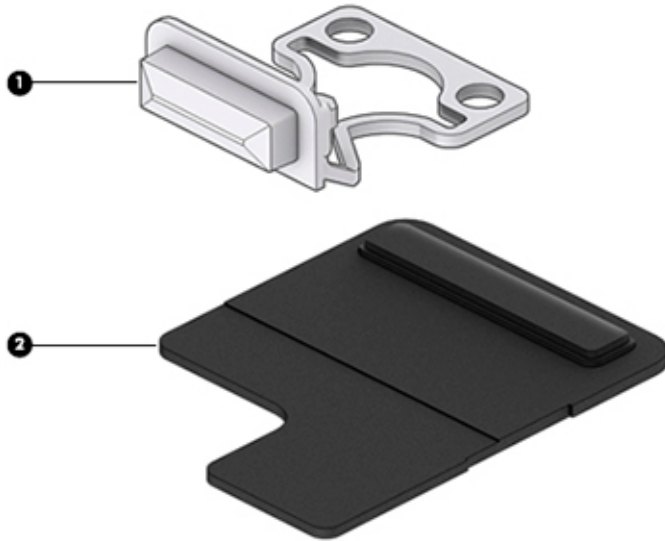

Item	Description	Spare part number
	Plastics Kit , includes the following parts:	L29889-001
(1)	Power LED bar	
(2)	Fingerprint reader insert (for use in models without a fingerprint reader)	

Bracket Kit

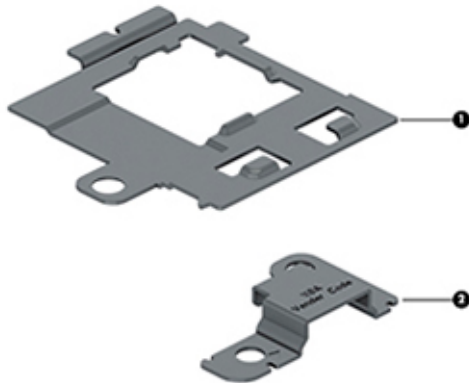

Item	Description	Spare part number
	Bracket Kit , includes the following parts:	L29057-001
(1)	Fingerprint reader bracket	
(2)	USB reader bracket	

Miscellaneous parts

Description	Spare part number
AC adapters	
65-W Smart AC power adapter, 4.5 mm barrel connector, S-3P	913691-850
65-W Smart AC power adapter, 4.5 mm barrel connector, RC	710412-001
45-W Smart AC power adapter, 4.5 mm barrel connector	741553-850
Power cord (C5, 1.0-m), for use in:	
Argentina	L19357-001
Australia	L19358-001
Brazil	L19359-001
Denmark	L19360-001
Europe (Austria, Belgium, Finland, France, Germany, the Netherlands, Norway and Sweden)	L19361-001
India	L19363-001
Israel	L19362-001
Italy	L19364-001
North America	L19367-001
The People's Republic of China	L19368-001
South Korea	L19366-001
United Kingdom	L19373-001
Active stylus	834590-001
Rubber Kit (includes speaker rubber, power button board sponge, and rubber WWAN insert; for use in models without a WWAN module)	L28270-001
Screw Kit	L28272-001
HP USB Laser Mouse	674318-001
HP Comfort Grip Wireless Mouse	691922-001
HP USB Travel Mouse	757770-001
Top load case	679921-001
Messenger bag	679922-001
Backpack	679923-001
HP keyed cable lock	840158-001
HP Smart AC Adapter dongle, 7.4 mm	734734-001
HP Elite USB-C Docking Station	844550-001
HP USB-C Mini Dock	935327-001
HP USB Travel Dock	844551-001

4 Removal and replacement procedures preliminary requirements

Tools required

You will need the following tools to complete the removal and replacement procedures:

- Flat-bladed screwdriver
- Phillips P0 and P1 screwdrivers
- Torx T8 screwdriver

Service considerations

The following sections include some of the considerations that you must keep in mind during disassembly and assembly procedures.

 **NOTE:** As you remove each subassembly from the computer, place the subassembly (and all accompanying screws) away from the work area to prevent damage.

Plastic parts

 **CAUTION:** Using excessive force during disassembly and reassembly can damage plastic parts. Use care when handling the plastic parts. Apply pressure only at the points designated in the maintenance instructions.

Cables and connectors

 **CAUTION:** When servicing the computer, be sure that cables are placed in their proper locations during the reassembly process. Improper cable placement can damage the computer.

Cables must be handled with extreme care to avoid damage. Apply only the tension required to unseat or seat the cables during removal and insertion. Handle cables by the connector whenever possible. In all cases, avoid bending, twisting, or tearing cables. Be sure that cables are routed in such a way that they cannot be caught or snagged by parts being removed or replaced. Handle flex cables with extreme care; these cables tear easily.

Drive handling

⚠ CAUTION: Drives are fragile components that must be handled with care. To prevent damage to the computer, damage to a drive, or loss of information, observe these precautions:

Before removing or inserting a hard drive, shut down the computer. If you are unsure whether the computer is off or in Hibernation, turn the computer on, and then shut it down through the operating system.

Before handling a drive, be sure that you are discharged of static electricity. While handling a drive, avoid touching the connector.

Before removing a diskette drive or optical drive, be sure that a diskette or disc is not in the drive and be sure that the optical drive tray is closed.

Handle drives on surfaces covered with at least one inch of shock-proof foam.

Avoid dropping drives from any height onto any surface.

After removing a hard drive, an optical drive, or a diskette drive, place it in a static-proof bag.

Avoid exposing a hard drive to products that have magnetic fields, such as monitors or speakers.

Avoid exposing a drive to temperature extremes or liquids.

If a drive must be mailed, place the drive in a bubble pack mailer or other suitable form of protective packaging and label the package "FRAGILE."

Electrostatic discharge damage

Electronic components are sensitive to electrostatic discharge (ESD). Circuitry design and structure determine the degree of sensitivity. Networks built into many integrated circuits provide some protection, but in many cases, ESD contains enough power to alter device parameters or melt silicon junctions.

A discharge of static electricity from a finger or other conductor can destroy static-sensitive devices or microcircuitry. Even if the spark is neither felt nor heard, damage may have occurred.

An electronic device exposed to ESD may not be affected at all and can work perfectly throughout a normal cycle. Or the device may function normally for a while, then degrade in the internal layers, reducing its life expectancy.

⚠ CAUTION: To prevent damage to the tablet when you are removing or installing internal components, observe these precautions:

Keep components in their electrostatic-safe containers until you are ready to install them.

Before touching an electronic component, discharge static electricity by using the guidelines described in this section.

Avoid touching pins, leads, and circuitry. Handle electronic components as little as possible.

If you remove a component, place it in an electrostatic-safe container.

The following table shows how humidity affects the electrostatic voltage levels generated by different activities.

⚠ CAUTION: A product can be degraded by as little as 700 V.

Typical electrostatic voltage levels			
Event	Relative humidity		
	10%	40%	55%
Walking across carpet	35,000 V	15,000 V	7,500 V
Walking across vinyl floor	12,000 V	5,000 V	3,000 V
Motions of bench worker	6,000 V	800 V	400 V
Removing DIPS from plastic tube	2,000 V	700 V	400 V
Removing DIPS from vinyl tray	11,500 V	4,000 V	2,000 V
Removing DIPS from Styrofoam	14,500 V	5,000 V	3,500 V
Removing bubble pack from PCB	26,500 V	20,000 V	7,000 V
Packing PCBs in foam-lined box	21,000 V	11,000 V	5,000 V

Packaging and transporting guidelines

Follow these grounding guidelines when packaging and transporting equipment:

- To avoid hand contact, transport products in static-safe tubes, bags, or boxes.
- Protect ESD-sensitive parts and assemblies with conductive or approved containers or packaging.
- Keep ESD-sensitive parts in their containers until the parts arrive at static-free workstations.
- Place items on a grounded surface before removing items from their containers.
- Always be properly grounded when touching a component or assembly.
- Store reusable ESD-sensitive parts from assemblies in protective packaging or nonconductive foam.
- Use transporters and conveyors made of antistatic belts and roller bushings. Be sure that mechanized equipment used for moving materials is wired to ground and that proper materials are selected to avoid static charging. When grounding is not possible, use an ionizer to dissipate electric charges.

Workstation guidelines

Follow these grounding workstation guidelines:

- Cover the workstation with approved static-shielding material.
- Use a wrist strap connected to a properly grounded work surface and use properly grounded tools and equipment.
- Use conductive field service tools, such as cutters, screw drivers, and vacuums.
- When fixtures must directly contact dissipative surfaces, use fixtures made only of static-safe materials.
- Keep the work area free of nonconductive materials, such as ordinary plastic assembly aids and Styrofoam.
- Handle ESD-sensitive components, parts, and assemblies by the case or PCM laminate. Handle these items only at static-free workstations.

- Avoid contact with pins, leads, or circuitry.
- Turn off power and input signals before inserting or removing connectors or test equipment.

Equipment guidelines

Grounding equipment must include either a wrist strap or a foot strap at a grounded workstation.

- When seated, wear a wrist strap connected to a grounded system. Wrist straps are flexible straps with a minimum of one megohm $\pm 10\%$ resistance in the ground cords. To provide proper ground, wear a strap snugly against the skin at all times. On grounded mats with banana-plug connectors, use alligator clips to connect a wrist strap.
- When standing, use foot straps and a grounded floor mat. Foot straps (heel, toe, or boot straps) can be used at standing workstations and are compatible with most types of shoes or boots. On conductive floors or dissipative floor mats, use foot straps on both feet with a minimum of one megohm resistance between the operator and ground. To be effective, the conductive must be worn in contact with the skin.

The following grounding equipment is recommended to prevent electrostatic damage:

- Antistatic tape
- Antistatic smocks, aprons, and sleeve protectors
- Conductive bins and other assembly or soldering aids
- Nonconductive foam
- Conductive tabletop workstations with ground cords of one megohm resistance
- Static-dissipative tables or floor mats with hard ties to the ground
- Field service kits
- Static awareness labels
- Material-handling packages
- Nonconductive plastic bags, tubes, or boxes
- Metal tote boxes
- Electrostatic voltage levels and protective materials

The following table lists the shielding protection provided by antistatic bags and floor mats.

Material	Use	Voltage protection level
Antistatic plastics	Bags	1,500 V
Carbon-loaded plastic	Floor mats	7,500 V
Metallized laminate	Floor mats	5,000 V

5 Removal and replacement procedures for Customer Self-Repair parts

 **CAUTION:** The Customer Self-Repair program is not available in all locations. Installing a part not supported by the Customer Self-Repair program may void your warranty. Check your warranty to determine if Customer Self-Repair is supported in your location.

 **NOTE:** HP continually improves and changes product parts. For complete and current information on supported parts for your computer, go to <http://partsurfer.hp.com>, select your country or region, and then follow the on-screen instructions.

Component replacement procedures

 **NOTE:** Please read and follow the procedures described here to access and replace Customer Self-Repair parts successfully.

 **NOTE:** Details about your computer, including model, serial number, product key, and length of warranty, are on the service tag at the bottom of your computer. See [Labels on page 16](#) for details.

This chapter provides removal and replacement procedures for Customer Self-Repair parts.

There are as many as six screws that must be removed, replaced, or loosened when servicing Customer Self-Repair parts. Make special note of each screw size and location during removal and replacement.

Battery Safe mode

Before removing internal components, you must place the computer in “Battery Safe mode.” This mode avoids short-circuits or system malfunction by removing power from internal components.

To place the computer in “Battery Safe mode,” follow these steps:

1. With the computer turned off and AC adapter connected, press the following key and button combination: **Windows key + Backspace key + Power button**.
2. Turn the computer on to initiate “Battery Safe mode.”
3. After the computer powers off, disconnect the AC adapter.

In “Battery Safe mode,” the power button will not turn the computer on if the AC adapter is not connected.

To disengage “Battery Safe mode,” plug in the AC adapter and press the power button.

Service doors

Description	Spare part number
Service door (UMA models)	L29058-001
Service door (Discrete models)	L34117-001

The bottom of the computer has two service doors. The drive service door provides access to the hard drive and M.2 solid-state drive. The main service door provides access to the memory modules, wireless modules, and keyboard screws.

Before removing the service doors, follow these steps:

1. Shut down the computer. If you are unsure whether the computer is off or in Hibernation, turn the computer on, and then shut it down through the operating system.
2. Place the computer in “Battery Safe mode” ([Battery Safe mode on page 31](#)).
3. Disconnect all external devices connected to the computer.
4. Disconnect the power from the computer by first unplugging the power cord from the AC outlet, and then unplugging the AC adapter from the computer.

Remove the service door:

1. Loosen the captive Phillips screw **(1)**.
2. Lift the bottom of the door upward **(2)**, and then remove the door from the computer **(3)**.

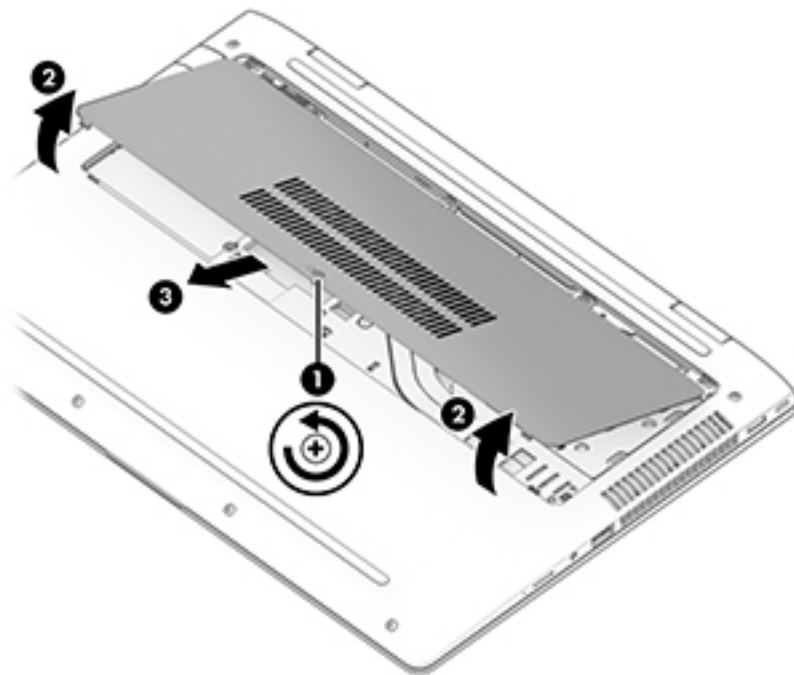

Reverse these procedures to install the service door.

Memory modules

Description	Spare part number
16-GB (DDR4-2400)	865396-855
8-GB (DDR4-2400)	862398-855
4-GB (DDR4-2400)	820569-005

Update BIOS before adding memory modules

Before adding new memory, make sure you update the computer to the latest BIOS.

 **CAUTION:** Failure to update the computer to the latest BIOS prior to installing new memory may result in various system problems.

To update BIOS:

1. Navigate to www.hp.com.
2. Move the cursor over **Support** to display the pull-down menu, and then click **Software & drivers**.
3. Type your product name, number, or serial number, and then click **Find**.
4. Click **BIOS**, and then click **Download**.
5. Follow the on-screen instructions.

Before removing the memory module, follow these steps:

1. Shut down the computer. If you are unsure whether the computer is off or in Hibernation, turn the computer on, and then shut it down through the operating system.
2. Place the computer in “Battery Safe mode” ([Battery Safe mode on page 31](#)).
3. Disconnect all external devices connected to the computer.
4. Disconnect the power from the computer by first unplugging the power cord from the AC outlet, and then unplugging the AC adapter from the computer.
5. Remove the service door ([Service doors on page 32](#)).

Remove the memory module:

1. Spread the retaining tabs **(1)** on each side of the memory module slot to release the memory module. (The edge of the module opposite the slot rises away from the computer.)

2. Remove the memory module (2) by pulling the module away from the slot at an angle.

 **NOTE:** Memory modules are designed with a notch to prevent incorrect insertion into the memory module slot.

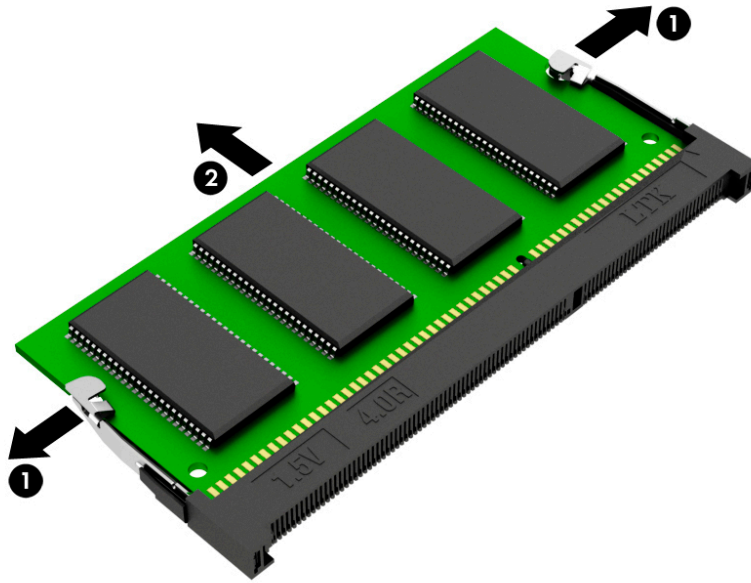

Reverse this procedure to install a memory module.

WLAN/Bluetooth combo card

The computer uses a card that provides both WLAN and Bluetooth functionality.

Description	Spare part number
Intel Dual Band Wireless-AC 8265, 802.11ac, 2x2 Wi-Fi + Bluetooth 4.2 combination adapter	851594-001
Realtek RTL8822BE 802.11AC 2x2 Wi-Fi + Bluetooth 4.2 combination adapter	915623-001

Before removing the WLAN module, follow these steps:

1. Shut down the computer. If you are unsure whether the computer is off or in Hibernation, turn the computer on, and then shut it down through the operating system.
2. Place the computer in “Battery Safe mode” ([Battery Safe mode on page 31](#)).
3. Disconnect all external devices connected to the computer.
4. Disconnect the power from the computer by first unplugging the power cord from the AC outlet, and then unplugging the AC adapter from the computer.
5. Remove the service door ([Service doors on page 32](#)).

Remove the WLAN module:

1. Disconnect the WLAN antenna cables **(1)** from the terminals on the WLAN module.





NOTE: The WLAN antenna cable labeled “1” connects to the WLAN module “Main” terminal labeled “1”. The WLAN antenna cable labeled “2” connects to the WLAN module “Aux” terminal labeled “2”. If the computer is equipped with an 802.11a/b/g/n WLAN module, the yellow WLAN antenna cable connects to the middle terminal on the WLAN module.

2. Remove the Phillips M2.0x4.0 screw **(2)** that secures the WLAN module to the computer. (The edge of the module opposite the slot rises away from the computer.)

3. Remove the WLAN module (3) by pulling the module away from the slot at an angle.

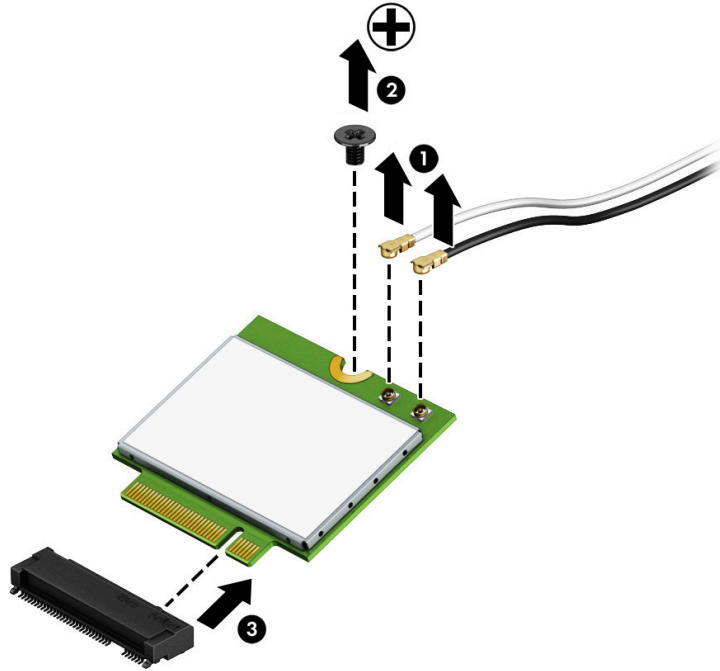
 **NOTE:** WLAN modules are designed with a notch to prevent incorrect insertion.



 **NOTE:** If the WLAN antennas are not connected to the terminals on the WLAN module, the protective sleeves must be installed on the antenna connectors, as shown in the following illustration.

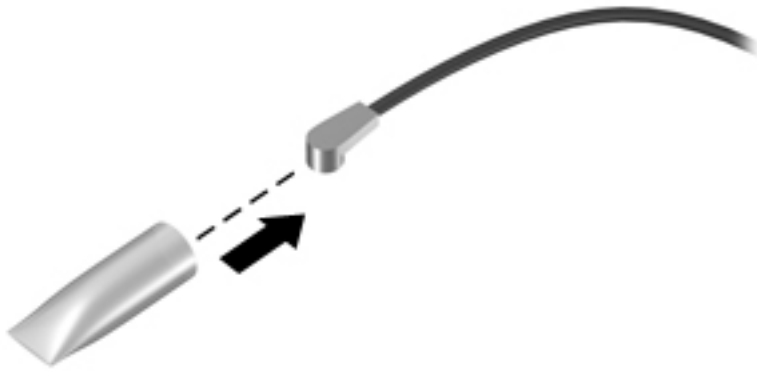

Reverse this procedure to install the WLAN module.

WWAN module



NOTE: The WWAN module and the WLAN module are not interchangeable.

Description	Spare part number
Huawei HP It4132, LTE/HSPA+ w/GPS M.2	845710-001
Intel XMM 7360 LTE-Advanced	917823-001

Before removing the WWAN module, follow these steps:

1. Shut down the computer. If you are unsure whether the computer is off or in Hibernation, turn the computer on, and then shut it down through the operating system.
2. Place the computer in “Battery Safe mode” ([Battery Safe mode on page 31](#)).
3. Disconnect all external devices connected to the computer.
4. Disconnect the power from the computer by first unplugging the power cord from the AC outlet, and then unplugging the AC adapter from the computer.
5. Remove the service door ([Service doors on page 32](#)).

Remove the WWAN module:

1. Disconnect the WWAN antenna cables **(1)** from the terminals on the WWAN module.





NOTE: The red WWAN antenna cable is connected to the WWAN module “Main” terminal. The blue WWAN antenna cable is connected to the WWAN module “Aux” terminal.

2. Remove the Phillips M2.0×4.0 screw **(2)** that secures the WWAN module to the system board.

3. Remove the WWAN module (3) by pulling the module away from the slot.

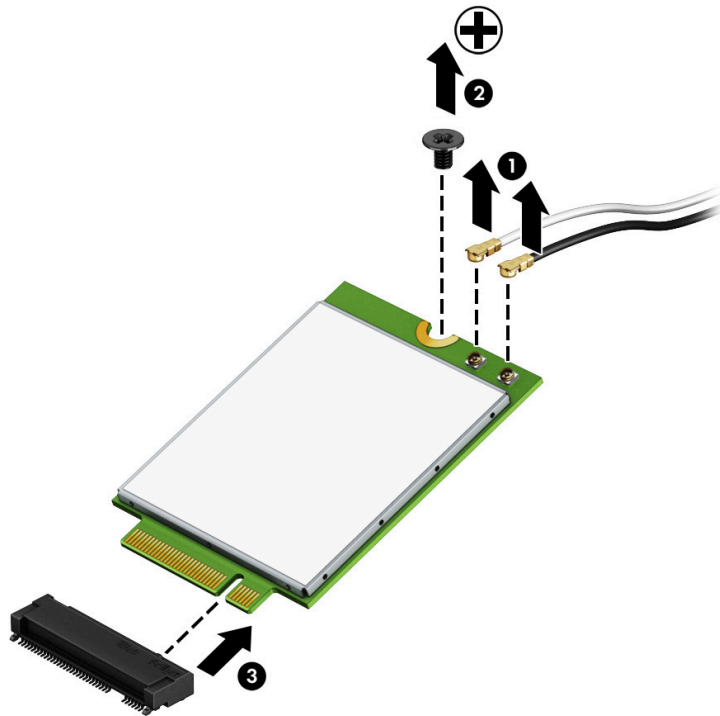
 **NOTE:** WWAN modules are designed with a notch to prevent incorrect insertion.



 **NOTE:** If the WWAN antennas are not connected to the terminals on the WWAN module, the protective sleeves must be installed on the antenna connectors, as shown in the following illustration.

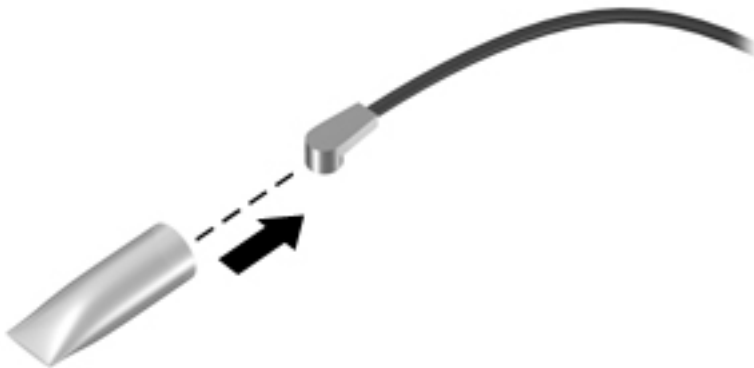

Reverse this procedure to install the WWAN module.

M.2 solid-state drive

Description	Spare part number
512-GB, PCIe, TLC	L28275-001
256-GB, PCIe	L28274-001
256-GB, SATA-3, TLC	L33505-001
128-GB, SATA-3	L28273-001

Before removing the solid-state drive, follow these steps:

1. Shut down the computer. If you are unsure whether the computer is off or in Hibernation, turn the computer on, and then shut it down through the operating system.
2. Place the computer in “Battery Safe mode” ([Battery Safe mode on page 31](#)).
3. Disconnect all external devices connected to the computer.
4. Disconnect the power from the computer by first unplugging the power cord from the AC outlet, and then unplugging the AC adapter from the computer.
5. Remove the service door ([Service doors on page 32](#)).

Remove the solid-state drive:

1. Remove the Phillips M2.0×4.0 screw **(1)** that secures the solid-state drive to the computer. (The edge of the module opposite the slot rises away from the computer.)
2. Remove the solid-state drive **(2)** by pulling the module away from the slot at an angle.

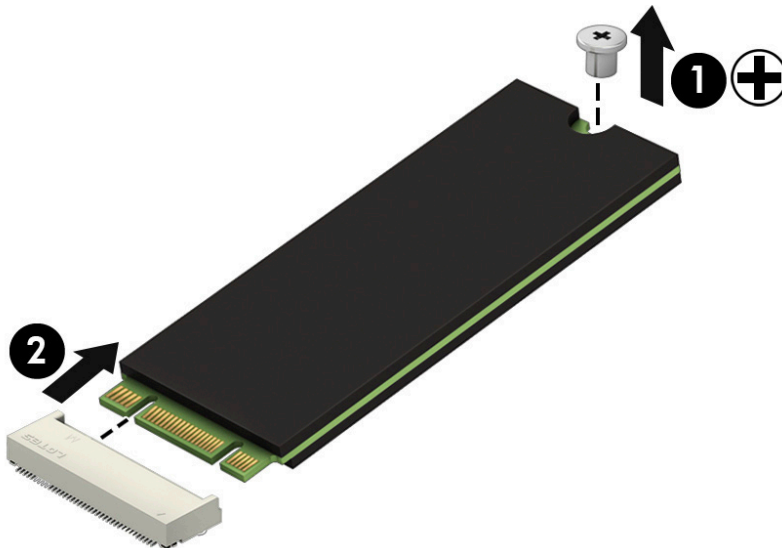

Reverse this procedure to install the solid-state drive.

Keyboard

In this section, the first table provides the main spare part number for the keyboards. The second table provides the country codes.

Description	Spare part number
Keyboard, no backlight	L28408-xxx
Keyboard, backlit	L28406-xxx

For use in country or region	Spare part number	For use in country or region	Spare part number	For use in country or region	Spare part number
Belgium	-A41	Iceland	-DD1	Slovenia	-BA1
Brazil	-201	India	-D61	South Korea	-AD1
Bulgaria	-261	Israel	-BB1	Spain	-071
Canada	-DB1	Italy	-061	Switzerland	-BG1
Czech Republic and Slovakia	-FL1	Latin America	-161	Taiwan	-AB1
Denmark, Finland, and Norway	-DH1	The Netherlands	-B31	Thailand	-281
France	-051	Northern Africa	-FP1	Turkey	-141
Germany	-041	Portugal	-131	Ukraine	-BD1
Greece	-151	Russia	-251	United Kingdom	-031
Hungary	-211	Saudi Arabia	-171	United States	-001

Before removing the keyboard, follow these steps:

1. Shut down the computer. If you are unsure whether the computer is off or in Hibernation, turn the computer on, and then shut it down through the operating system.
2. Place the computer in “Battery Safe mode” ([Battery Safe mode on page 31](#)).
3. Disconnect all external devices connected to the computer.
4. Disconnect the power from the computer by first unplugging the power cord from the AC outlet, and then unplugging the AC adapter from the computer.
5. Remove the service door ([Service doors on page 32](#)).

Remove the keyboard:

1. Remove the two Phillips M2.5×5.0 screws that secure the keyboard to the computer **(1)**.

2. Insert a tool into the access hole near the WLAN module in the upper left of the computer and push to disengage the keyboard from the top cover (2).

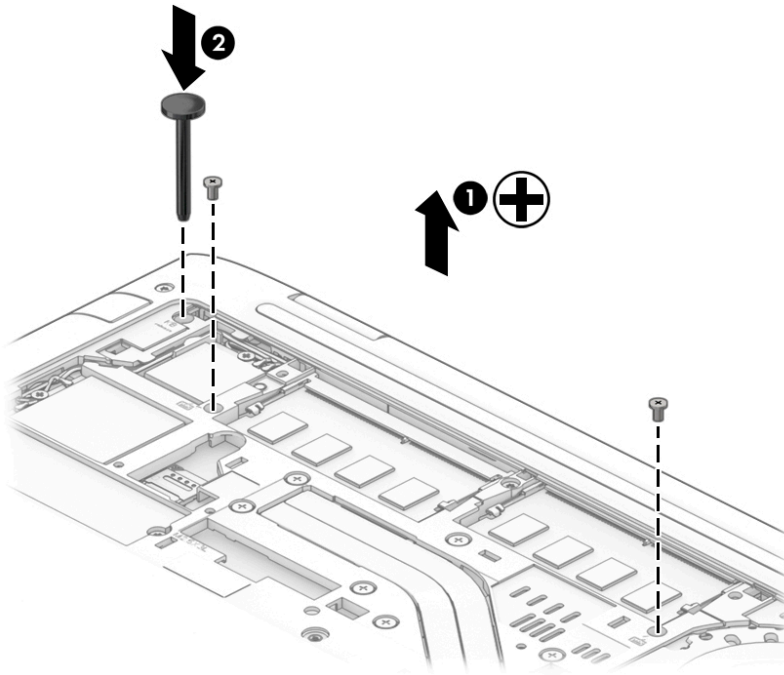

3. Lift the top of the keyboard upward.



NOTE: A cable (or cables) connect the bottom of the keyboard to the system board. Make sure not to prematurely pull the cables out of the system board connector(s).



4. Rotate the keyboard until it rests on the palm rest (1).
5. If applicable, disconnect the backlight cable from the system board ZIF connector.
6. Disconnect the keyboard cable from the system board reverse ZIF connector (3).

7. Remove the keyboard (4).

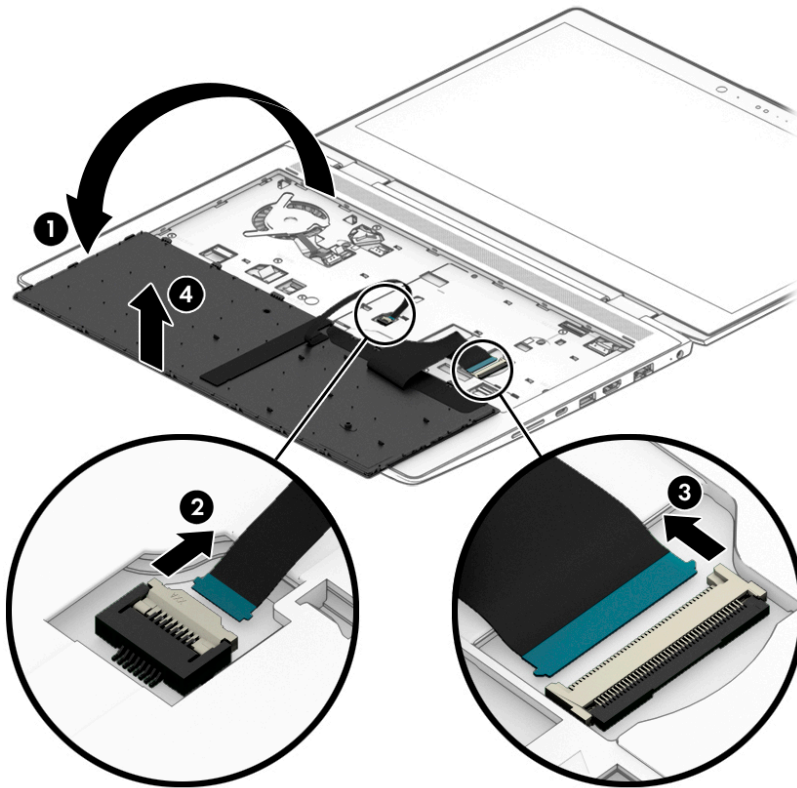

Reverse this procedure to install the keyboard.

6 Removal and replacement procedures for Authorized Service Provider parts

 **CAUTION:** Components described in this chapter should only be accessed by an authorized service provider. Accessing these parts can damage the computer or void the warranty.

 **NOTE:** HP continually improves and changes product parts. For complete and current information on supported parts for your computer, go to <http://partsurfer.hp.com>, select your country or region, and then follow the on-screen instructions.

Component replacement procedures

 **NOTE:** Details about your computer, including model, serial number, product key, and length of warranty, are on the service tag at the bottom of your computer. See [Labels on page 16](#) for details.

This chapter provides removal and replacement procedures for Authorized Service Provider only parts.

There are as many as 55 screws that must be removed, replaced, or loosened when servicing Authorized Service Provider only parts. Make special note of each screw size and location during removal and replacement.

Display subcomponents (panel, cameras, touch control board)

 **NOTE:** Display assemblies are spared at the subcomponent level only.

This section illustrates how to remove the display panel, camera modules, and touch control board without removing the display from the computer. The [Display assembly on page 62](#) section illustrates removing all display subcomponents.

To remove the display assembly subcomponents, follow these steps:

1. Shut down the computer. If you are unsure whether the computer is off or in Hibernation, turn the computer on, and then shut it down through the operating system.
2. Place the computer in “Battery Safe mode” ([Battery Safe mode on page 31](#)).
3. Disconnect all external devices connected to the computer.
4. Disconnect the power from the computer by first unplugging the power cord from the AC outlet, and then unplugging the AC adapter from the computer.

Remove the display assembly subcomponents:

1. Open the computer as far as possible.
2. To remove the display panel:
 - a. Use a non-marking, non-conductive tool to disengage the panel from the top of the enclosure **(1)**.
 - b. Starting at the top and working around, flex and pry to disengage the panel **(2)**.

- c. Rotate the panel onto the keyboard **(3)**.



- 3. To remove the camera module:

HD camera

- a. Position the display assembly with the top edge toward you.
- b. Lift the tape from the connector on the camera module **(1)**, and then disconnect the cable **(2)** from the module.

- c. Lift up to disengage the HD camera module from the adhesive that secures it to the display, and then remove it from the display (3).

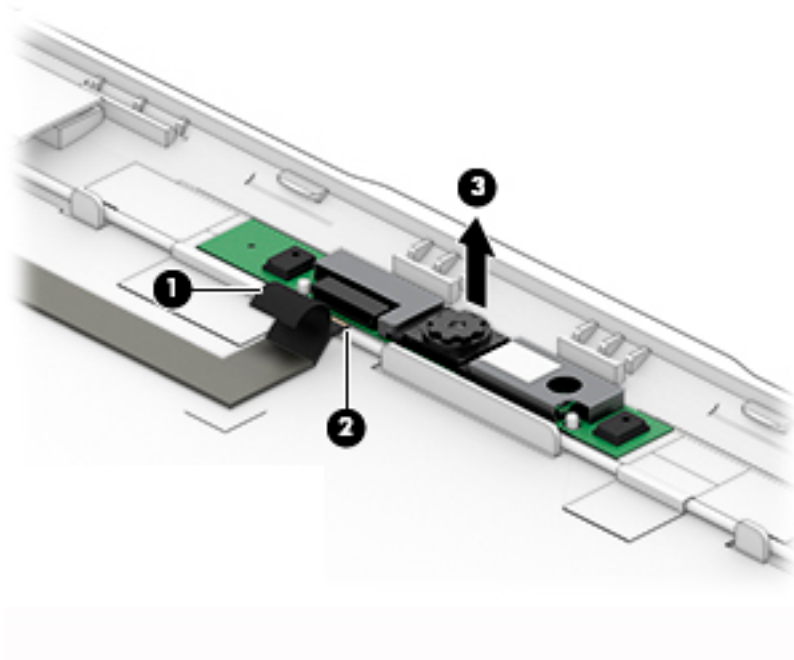

IR camera

- a. Position the display assembly with the top edge toward you.
- b. Lift the tape from the connectors on both ends of the camera module (1).
- c. Lift up to disengage the IR camera module from the adhesive that secures it to the display (2).
- d. Disconnect the cables (3) from both ends of the module.

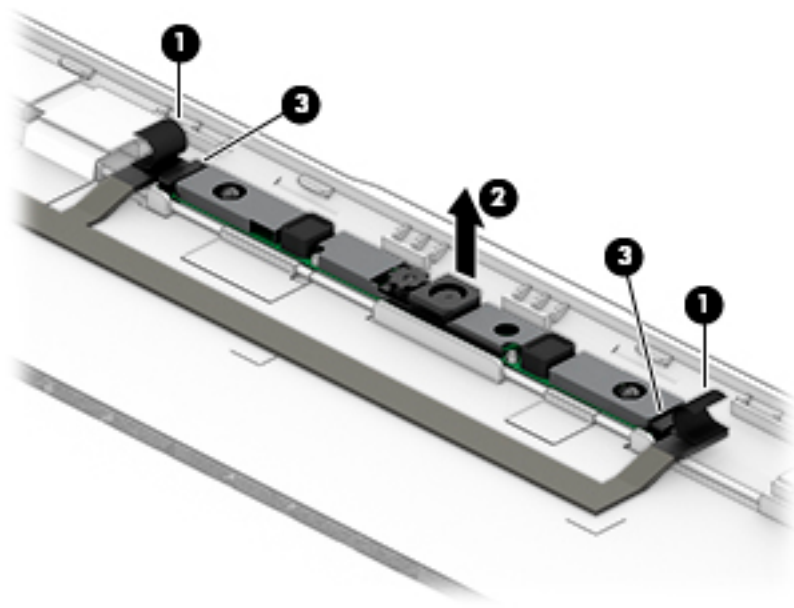

4. To remove the display panel:

- a. Lift the tape from atop the connector on the bottom of the display panel **(1)**, lift the connector bracket **(2)**, and then disconnect the display cable from the display **(3)**.
- b. Lift the tape from atop the connectors on both ends of the touch control board **(4)**.
- c. Disconnect the cables from the ZIF connector **(5)** and the reverse ZIF connector **(6)** on the touch control board.
- d. Disconnect the two flat ribbon cables from the reverse ZIF connectors on the touch control board **(7)**.
- e. Remove the cable that routes under the flat ribbon cables **(8)**.

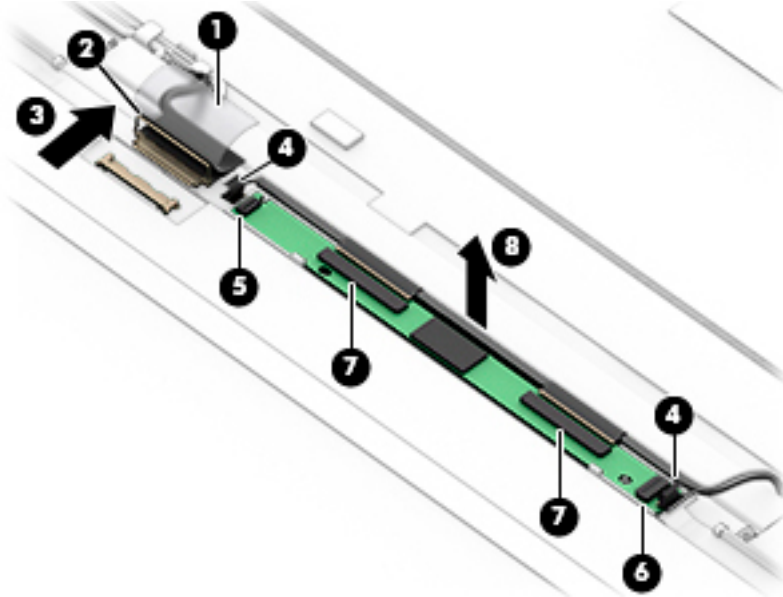

- f. After disconnecting the cables from the touch control board, you can remove the display panel from the display enclosure.
- g. If you need to replace the touch control board, lift the board up to disengage the adhesive that secures it, and then remove the board from the display.

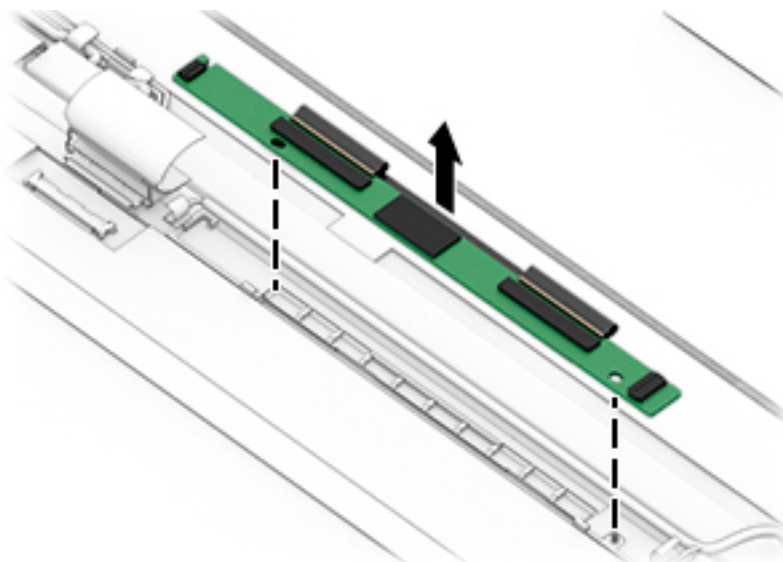

Reverse this procedure to reassemble and install the display assembly components.

Top cover

Description	Spare part number
Top cover for use in models with UMA graphics memory	L28268-001
Top cover for use in models with discrete graphics memory	L28269-001

Before removing the top cover, follow these steps:

1. Shut down the computer. If you are unsure whether the computer is off or in Hibernation, turn the computer on, and then shut it down through the operating system.
2. Place the computer in “Battery Safe mode” ([Battery Safe mode on page 31](#)).
3. Disconnect all external devices connected to the computer.
4. Disconnect the power from the computer by first unplugging the power cord from the AC outlet, and then unplugging the AC adapter from the computer.
5. Remove the following components:
 - a. Service door ([Service doors on page 32](#)).
 - b. Keyboard ([Keyboard on page 40](#))

Remove the top cover:

1. Position the computer upside-down with the front toward you.
2. Remove the seven Torx T8 2.5×6.0 screws from around the edges of the computer.

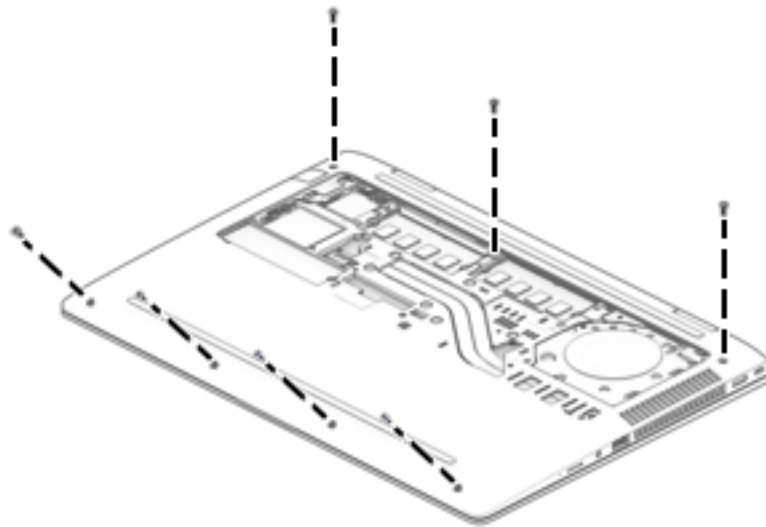

3. Position the computer upright and open it as far as possible.
4. Disconnect the TouchPad cable **(1)** and the fingerprint reader cable **(2)** from the ZIF connectors under the keyboard.

5. Remove the seven Torx T8 2.5×6.0 screws (3) that secure the top cover to the computer.

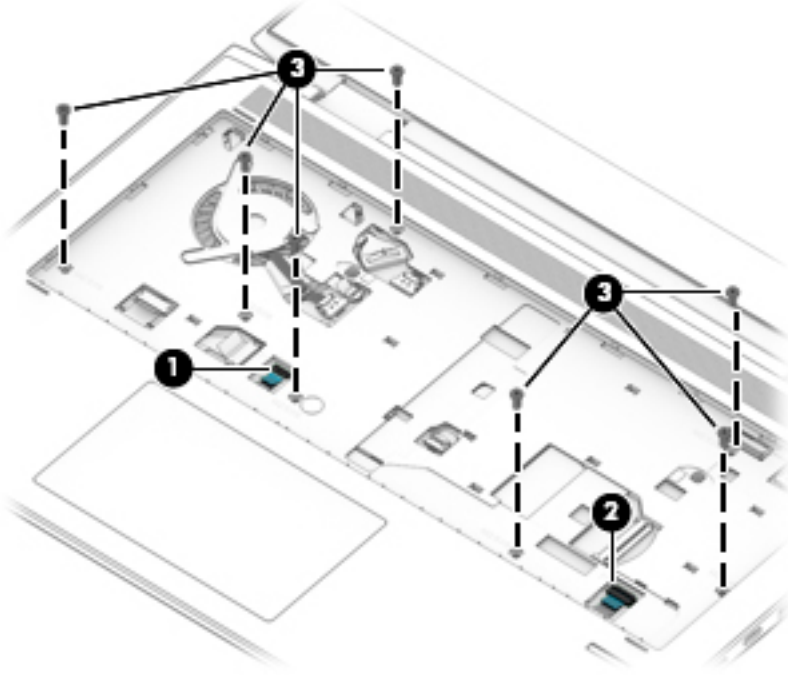

6. Use a tool to pry along the seam between the top cover and the computer chassis (1), and then remove the top cover from the computer (2).

 **NOTE:** The top cover may be secured very tightly to the computer.

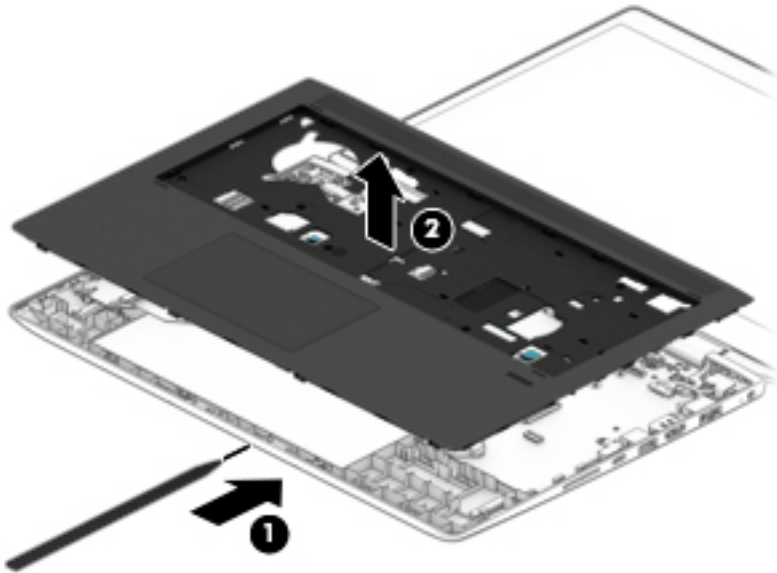

Reverse this procedure to install the top cover.

TouchPad assembly

Description	Spare part number
TouchPad assembly	L28253-001
TouchPad assembly cable (included in Cable Kit)	L28263-001

Before removing the TouchPad assembly, follow these steps:

1. Shut down the computer. If you are unsure whether the computer is off or in Hibernation, turn the computer on, and then shut it down through the operating system.
2. Place the computer in “Battery Safe mode” ([Battery Safe mode on page 31](#)).
3. Disconnect all external devices connected to the computer.
4. Disconnect the power from the computer by first unplugging the power cord from the AC outlet, and then unplugging the AC adapter from the computer.
5. Remove the following components:
 - a. Service door ([Service doors on page 32](#)).
 - b. Keyboard ([Keyboard on page 40](#))
 - c. Top cover ([Top cover on page 47](#))

Remove the TouchPad assembly:

1. Position the top cover upside-down.
2. Disconnect the cable from the ZIF connector on the TouchPad **(1)**.
3. Remove the six broad head Phillips M2.0×3.0 screws **(2)** that secure the TouchPad to the top cover.
4. Lift the TouchPad off the top cover **(3)**.

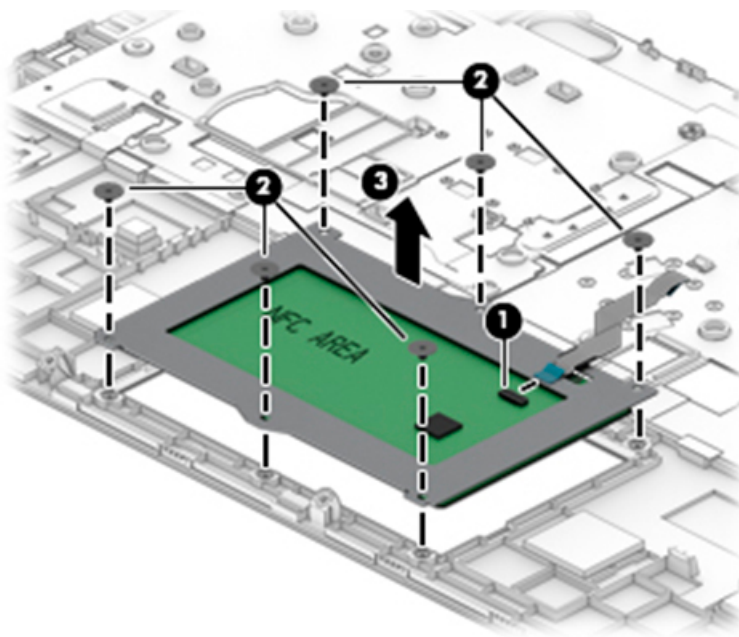

Reverse this procedure to install the TouchPad assembly.

Fingerprint reader assembly

Description	Spare part number
Fingerprint reader assembly	L28254-001
Fingerprint reader bracket (included in Bracket Kit)	L29057-001
Fingerprint reader insert (included in Plastics Kit; for use in models without a fingerprint reader)	L29889-001

Before removing the fingerprint reader assembly, follow these steps:

1. Shut down the computer. If you are unsure whether the computer is off or in Hibernation, turn the computer on, and then shut it down through the operating system.
2. Place the computer in “Battery Safe mode” ([Battery Safe mode on page 31](#)).
3. Disconnect all external devices connected to the computer.
4. Disconnect the power from the computer by first unplugging the power cord from the AC outlet, and then unplugging the AC adapter from the computer.
5. Remove the following components:
 - a. Service door ([Service doors on page 32](#)).
 - b. Keyboard ([Keyboard on page 40](#))
 - c. Top cover ([Top cover on page 47](#))

Remove the fingerprint reader assembly:

1. Position the top cover upside-down.
2. Slide the bracket toward the side of the top cover, and then lift it off the fingerprint reader board **(1)**.

 **TIP:** A tool may be required to push and disengage the bracket.

3. Lift the fingerprint reader cable (2) and board (3) to disengage the adhesive that secures them to the top cover, and then remove the board and cable assembly from the top cover.

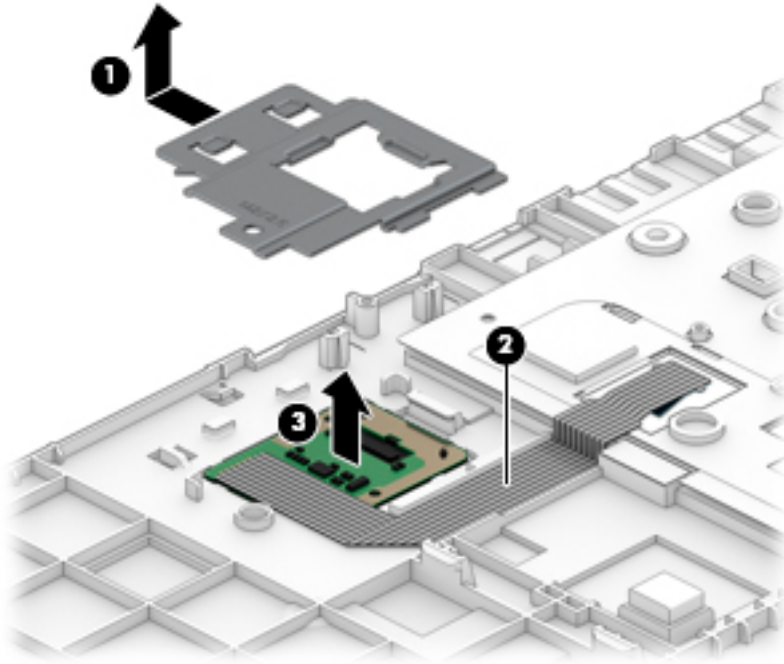

Reverse this procedure to install the fingerprint reader assembly.

Battery

Description	Spare part number
Battery, 4-cell, 48 WHr, 4.21 Ah	L12791-855

Before removing the battery, follow these steps:

1. Shut down the computer. If you are unsure whether the computer is off or in Hibernation, turn the computer on, and then shut it down through the operating system.
2. Place the computer in “Battery Safe mode” ([Battery Safe mode on page 31](#)).
3. Disconnect all external devices connected to the computer.
4. Disconnect the power from the computer by first unplugging the power cord from the AC outlet, and then unplugging the AC adapter from the computer.
5. Remove the following components:
 - a. Service door ([Service doors on page 32](#)).
 - b. Keyboard ([Keyboard on page 40](#))
 - c. Top cover ([Top cover on page 47](#))

To remove the battery:

1. Position the computer upright on a flat surface and open the display as far as possible.
2. Remove both I/O board cables from on top of the battery **(1)**.
3. Remove the four Torx T8 2.5×4.0 screws **(2)** that secure the battery to the computer.
4. Rotate the bottom of the battery upward, and then lift the battery out of the computer **(3)**.

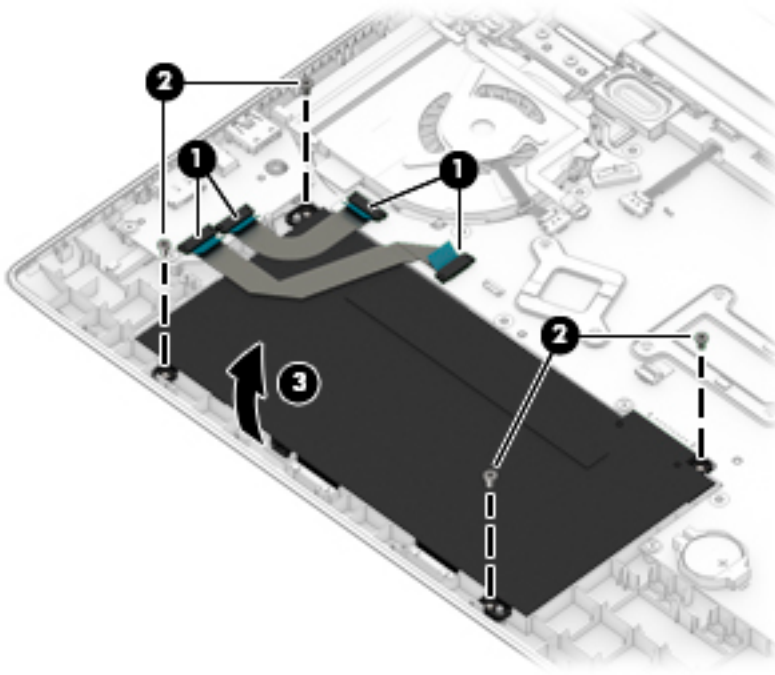

Reverse this procedure to install the battery.

I/O board

Description	Spare part number
I/O board	L28252-001
I/O board cables (included in Cable Kit)	L28263-001

Before removing the I/O board, follow these steps:

1. Shut down the computer. If you are unsure whether the computer is off or in Hibernation, turn the computer on, and then shut it down through the operating system.
2. Place the computer in “Battery Safe mode” ([Battery Safe mode on page 31](#)).
3. Disconnect all external devices connected to the computer.
4. Disconnect the power from the computer by first unplugging the power cord from the AC outlet, and then unplugging the AC adapter from the computer.
5. Remove the following components:
 - a. Service door ([Service doors on page 32](#)).
 - b. Keyboard ([Keyboard on page 40](#))
 - c. Top cover ([Top cover on page 47](#))
 - d. Battery ([Battery on page 52](#))

Remove the I/O board:

1. Remove the two Torx T8 2.5×4.0 screws (1) that secure the board to the computer.
2. Remove the I/O board from the computer (2).

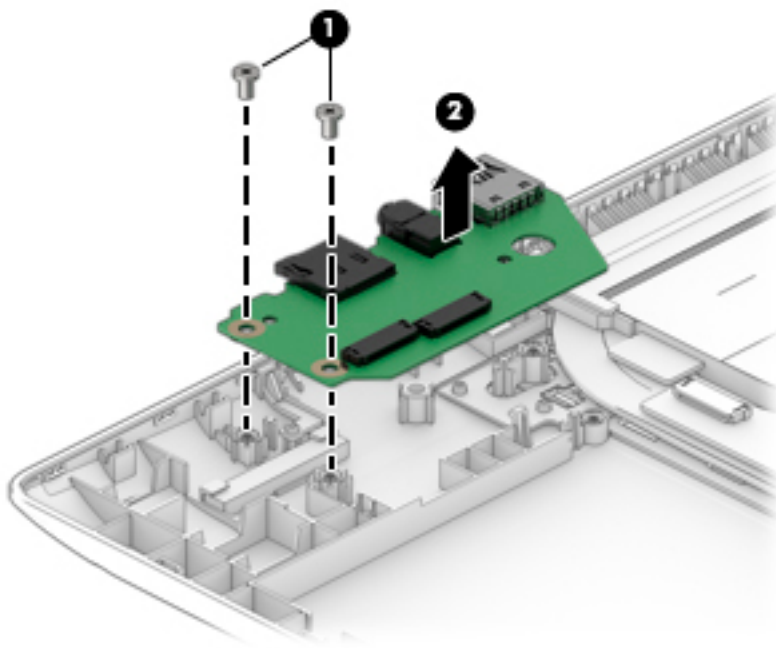

Reverse this procedure to install the I/O board.

RTC battery

Description	Spare part number
RTC battery	nto spared

Before removing the RTC battery, follow these steps:

1. Shut down the computer. If you are unsure whether the computer is off or in Hibernation, turn the computer on, and then shut it down through the operating system.
2. Place the computer in “Battery Safe mode” ([Battery Safe mode on page 31](#)).
3. Disconnect all external devices connected to the computer.
4. Disconnect the power from the computer by first unplugging the power cord from the AC outlet, and then unplugging the AC adapter from the computer.
5. Remove the following components:
 - a. Service door ([Service doors on page 32](#)).
 - b. Keyboard ([Keyboard on page 40](#))
 - c. Top cover ([Top cover on page 47](#))
 - d. Battery ([Battery on page 52](#))

Remove the RTC battery:

1. Use a tool to pry the battery out of the socket (1).
2. Remove the battery from the system board (2).

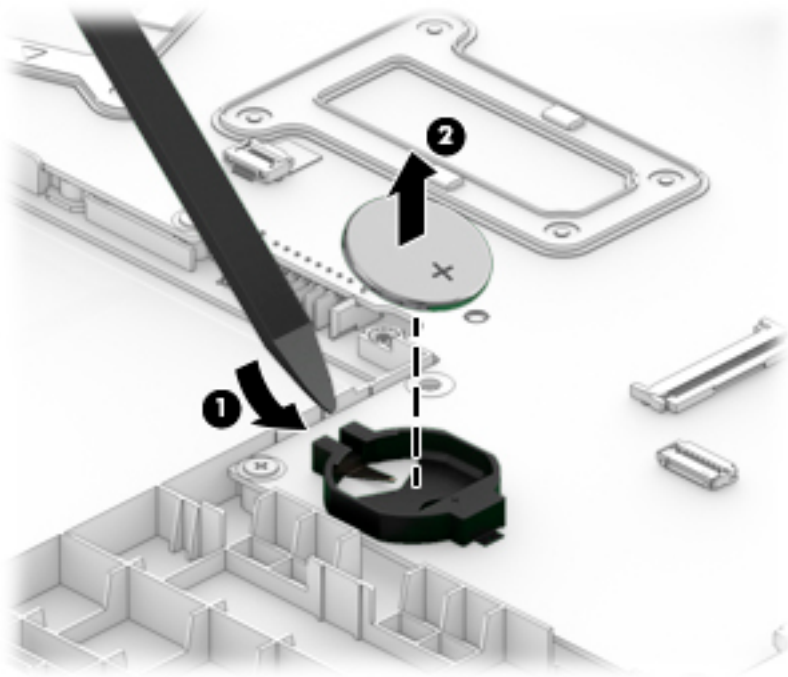

Reverse this procedure to install the RTC battery.

System board



NOTE: All system board spare part kits include replacement thermal material.

All system boards use the following part numbers:

xxxxxx-001: Non-Windows operating systems

xxxxxx-601: Windows 10 operating system

Description	Spare part number
System board with processor for use in models with UMA graphics:	
Intel Core i7-8550U processor	L28242-xxx
Intel Core i5-8350U processor	L35766-xxx
Intel Core i5-8250U processor (WWAN models)	L28244-xxx
Intel Core i5-8250U processor	L28241-xxx
Intel Core i3-8130U processor (WWAN models)	L28243-xxx
Intel Core i3-8130U processor	L28239-xxx
Intel Core i5-7200U processor	L28240-xxx
Intel Pentium 4415U processor	L31173-xxx
Intel Celeron 3865U processor	L28238-xxx
System board with processor for use in models with 2 GB of discrete graphics:	
Intel Core i7-8550U processor	L28248-xxx
Intel Core i5-8250U processor	L28247-xxx
Intel Core i3-8130U processor	L28245-xxx
Intel Core i5-7200U processor	L28246-xxx

Before removing the system board, follow these steps:

1. Shut down the computer. If you are unsure whether the computer is off or in Hibernation, turn the computer on, and then shut it down through the operating system.
2. Place the computer in “Battery Safe mode” ([Battery Safe mode on page 31](#)).
3. Disconnect all external devices connected to the computer.
4. Disconnect the power from the computer by first unplugging the power cord from the AC outlet, and then unplugging the AC adapter from the computer.
5. Remove the following components:
 - a. Service door ([Service doors on page 32](#)).
 - b. Keyboard ([Keyboard on page 40](#))
 - c. Top cover ([Top cover on page 47](#))
 - d. Battery ([Battery on page 52](#))

When replacing the system board, be sure to remove the following components (as applicable) from the defective system board and install on the replacement system board:

- Memory modules ([Memory modules on page 33](#))
- WLAN/Bluetooth module ([WLAN/Bluetooth combo card on page 35](#))
- WWAN module ([WWAN module on page 37](#))
- M.2 solid-state drive ([M.2 solid-state drive on page 39](#))
- Fan/heat sink ([Fan/heat sink assembly on page 58](#))

Remove the system board:

1. Disconnect the following cables from the system board:

(1): Power connector cable

(2): Display cable

(3): Speaker cable

(4): Display cable

(5): Display cable

(6): Power button board cable

(7): Fan cable

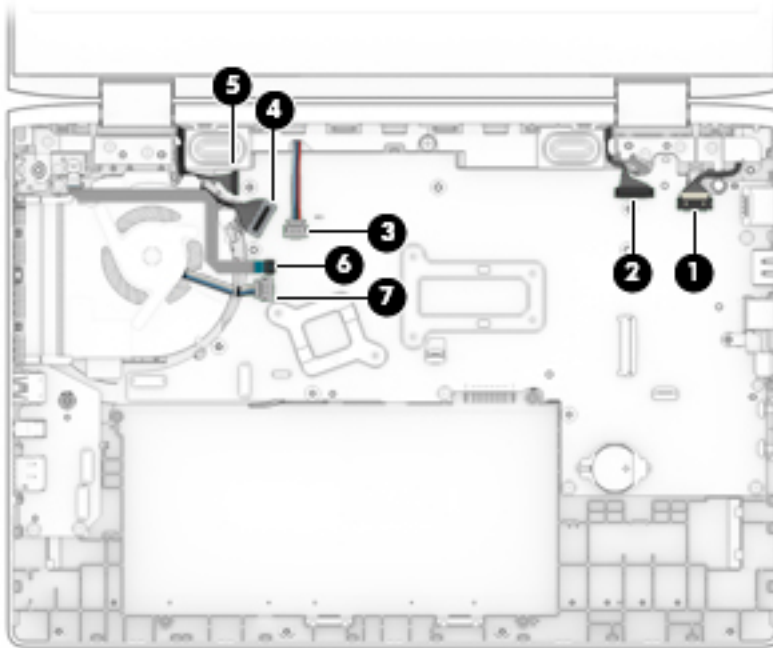

2. Remove the five Torx T8 2.5×4.0 screws (1) that secure the system board to the computer.
3. Remove the Torx T8 2.5×4.0 screw (2) that secures the fan.
4. Lift the bracket from atop the USB-Type C port (3).
The USB bracket is available using spare part number L29057-001.
5. Rotate the left side of the system board upward (4).

6. Pull the system board away from the connectors on the side of the chassis to remove it from the computer (5).

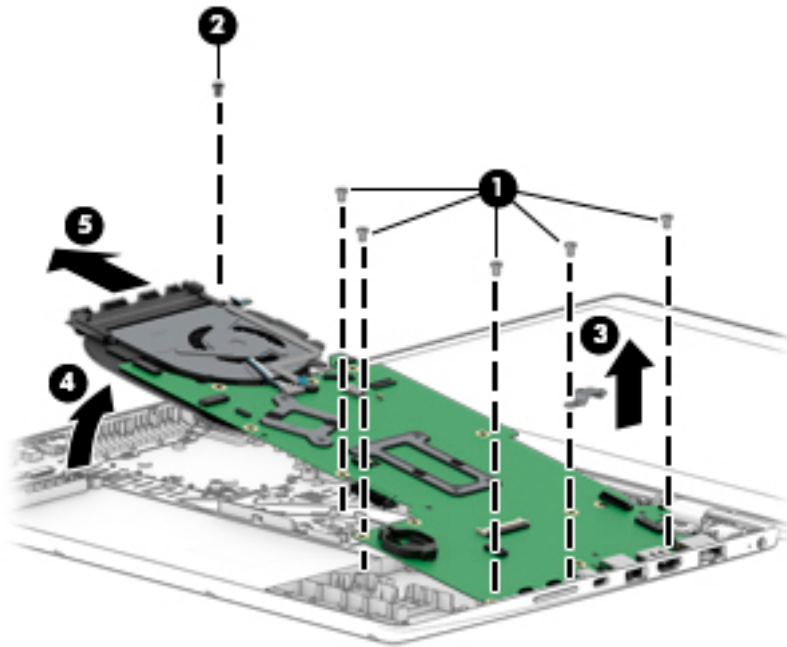

Reverse this procedure to install the system board.

Fan/heat sink assembly

All fan/heat sink assembly spare part kits include replacement thermal material.

Description	Spare part number
Fan/heat sink for use in models with UMA graphics	L28266-001
Fan/heat sink for use in models with discrete graphics	L28267-001

Before removing the fan/heat sink assembly, follow these steps:

1. Shut down the computer. If you are unsure whether the computer is off or in Hibernation, turn the computer on, and then shut it down through the operating system.
2. Place the computer in “Battery Safe mode” ([Battery Safe mode on page 31](#)).
3. Disconnect all external devices connected to the computer.
4. Disconnect the power from the computer by first unplugging the power cord from the AC outlet, and then unplugging the AC adapter from the computer.
5. Remove the following components:
 - a. Service door ([Service doors on page 32](#)).
 - b. Keyboard ([Keyboard on page 40](#))
 - c. Top cover ([Top cover on page 47](#))
 - d. Battery ([Battery on page 52](#))
 - e. System board ([System board on page 55](#))

Remove the fan/heat sink assembly:

1. Position the system board upside down with the fan/heat sink facing you.
2. **Discrete models:** In the order indicated on the heat sink, loosen the six captive Phillips screws **(1)-(6)** that secure the fan/heat sink to the system board.

- Lift the fan/heat sink from the system board (7).

 **IMPORTANT:** If replacing the fan/heat sink, be sure to remove the power button board cable that is adhered to the fan (8) and reinstall with the new fan/heat sink.

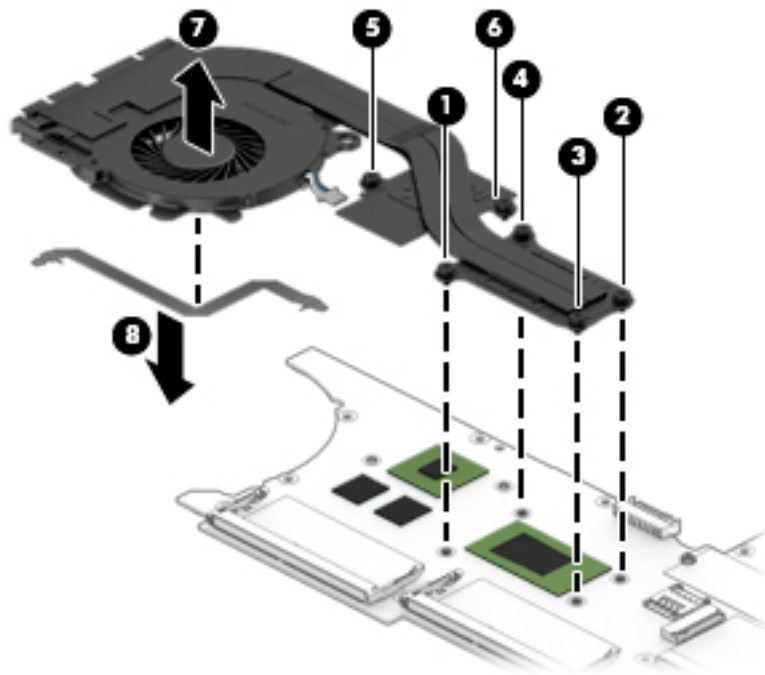

 **NOTE:** Thoroughly clean thermal material from the surfaces of the system board components (1)(3) and the heat sink (2)(4) each time you remove the heat sink. All fan/heat sink and processor spare part kits include thermal material.

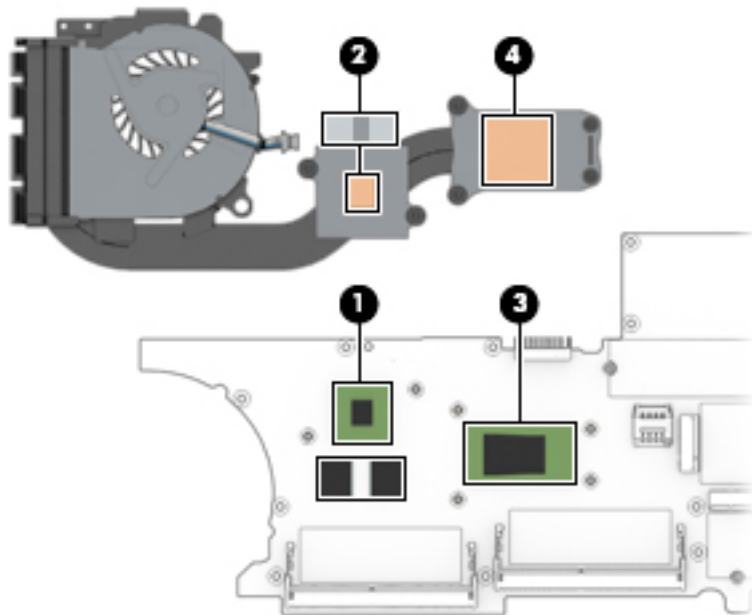

- UMA models:** In the order indicated on the heat sink, loosen the four captive Phillips screws (1)-(4) that secure the fan/heat sink to the system board.

5. Lift the fan/heat sink from the system board (5).

 **IMPORTANT:** If replacing the fan/heat sink, be sure to remove the power button board cable that is adhered to the fan (6) and reinstall with the new fan/heat sink.

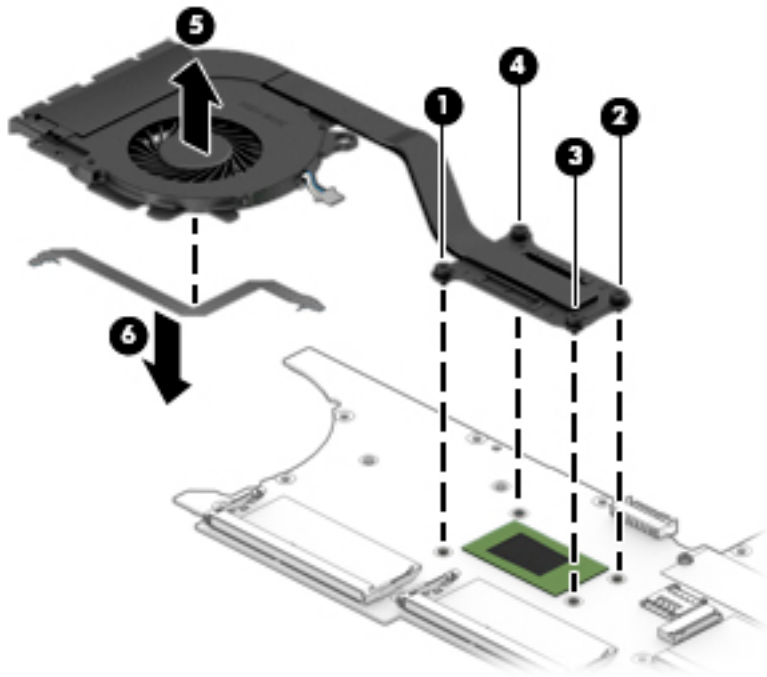

 **NOTE:** Thoroughly clean thermal material from the surfaces of the system board component (1) and the heat sink (2) each time you remove the fan/heat sink. All heat sink and processor spare part kits include thermal material.

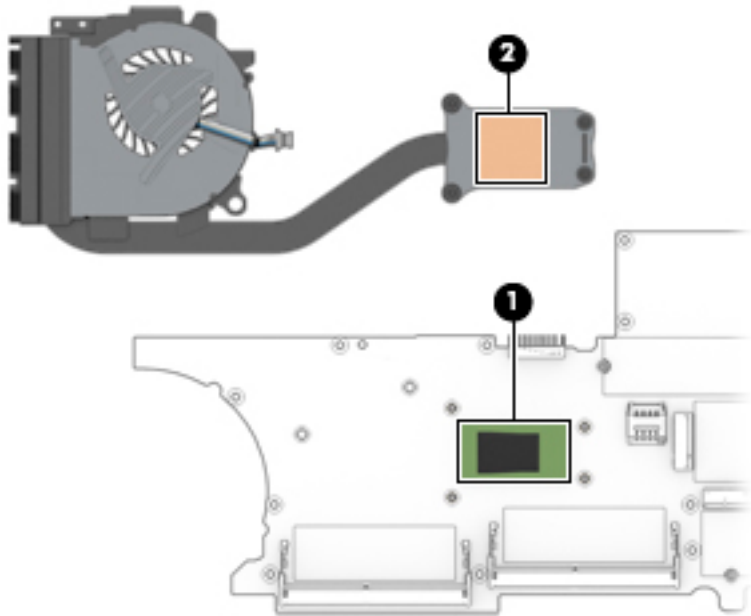

Reverse this procedure to install the fan/heat sink assembly.

Speaker assembly

Description	Spare part number
Speaker assembly	L28271-001

Before removing the speaker assembly, follow these steps:

1. Shut down the computer. If you are unsure whether the computer is off or in Hibernation, turn the computer on, and then shut it down through the operating system.
2. Place the computer in “Battery Safe mode” ([Battery Safe mode on page 31](#)).
3. Disconnect all external devices connected to the computer.
4. Disconnect the power from the computer by first unplugging the power cord from the AC outlet, and then unplugging the AC adapter from the computer.
5. Remove the following components:
 - a. Service door ([Service doors on page 32](#)).
 - b. Keyboard ([Keyboard on page 40](#))
 - c. Top cover ([Top cover on page 47](#))
 - d. Battery ([Battery on page 52](#))
 - e. System board ([System board on page 55](#))

Remove the speaker assembly:

1. Remove the Phillips M2.0×5.0 screw **(1)** that secures the speaker assembly to the computer.
2. Rotate the speaker assembly out from under the tabs in the computer **(2)**.

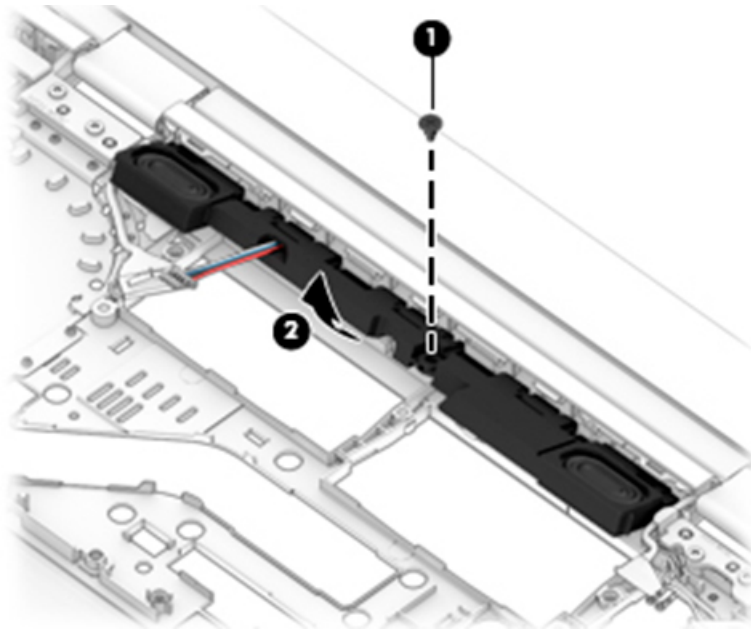

Reverse this procedure to install the speaker assembly.

Display assembly

 **NOTE:** Displays are spared only at the subcomponent level.

Before disassembling the display assembly, follow these steps:

1. Shut down the computer. If you are unsure whether the computer is off or in Hibernation, turn the computer on, and then shut it down through the operating system.
2. Place the computer in “Battery Safe mode” ([Battery Safe mode on page 31](#)).
3. Disconnect all external devices connected to the computer.
4. Disconnect the power from the computer by first unplugging the power cord from the AC outlet, and then unplugging the AC adapter from the computer.
5. Remove the following components:
 - a. Service door ([Service doors on page 32](#)).
 - b. Keyboard ([Keyboard on page 40](#))
 - c. Top cover ([Top cover on page 47](#))
 - d. Battery ([Battery on page 52](#))

Remove and disassemble the display assembly:

1. Remove the six Torx T8 2.5×6.0 screws **(1)** that secure the display assembly to the computer.
2. Disconnect the display cables from the system board **(2)**.

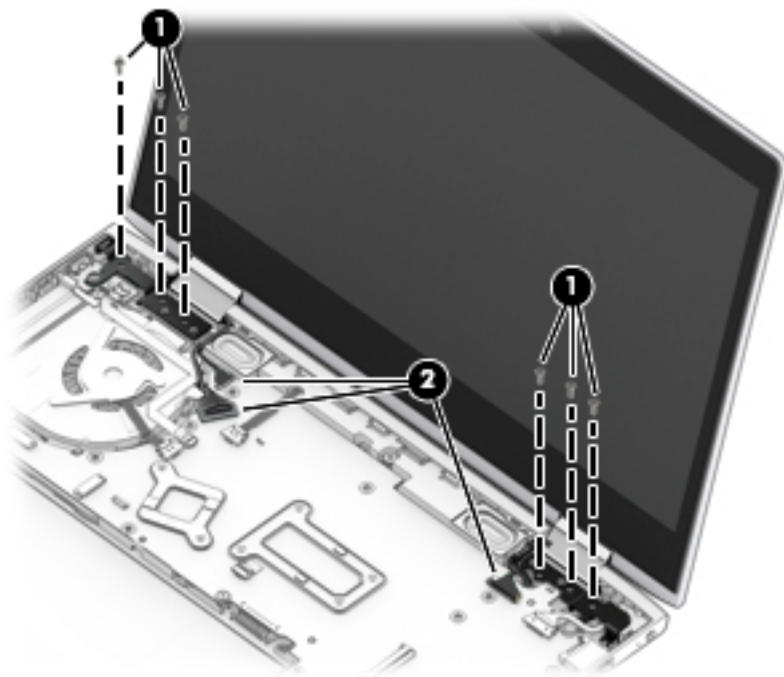

3. Close the display assembly partially, to about 30 degrees **(1)**.

4. Separate the display from the computer **(2)**, making sure the cable releases from the computer near the right hinge **(3)**.

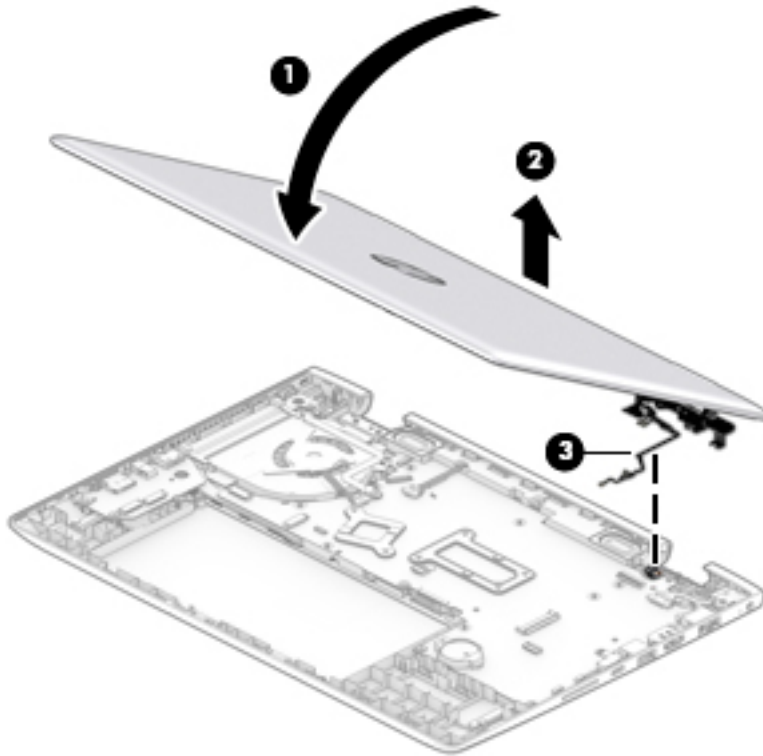

5. To remove the display panel:
 - a. Use a non-marking, non-conductive tool to disengage the panel from the top of the enclosure **(1)**.
 - b. Starting at the top and working around, flex and pry to disengage the panel **(2)**.

- c. Rotate the panel out of the display enclosure **(3)**.

Touch panel display kits are available using the following spare part numbers:

L28255-001: Display with an HD camera

L28256-001: Display with an HD+IR camera

L28257-001: Display with an HD camera, coaxial

L28258-001: Display with an HD+IR camera, coaxial

L28259-001: Display with an HD+IR camera on models with WWAN



NOTE: The display will not be connected to the computer as shown in the following illustration.



- 6. If it is necessary to remove the touch control board:

- a. Lift the tape from atop the connector on the bottom of the display panel **(1)**, lift the connector bracket **(2)**, and disconnect the display cable from the touch board **(3)**.
- b. Lift the tape from atop the connectors on both ends of the touch control board **(4)**.
- c. Disconnect the cables from the ZIF connector **(5)** and the reverse ZIF connector **(6)** on the touch control board.
- d. Disconnect the two flat ribbon cables from the reverse ZIF connectors on the touch control board **(7)**.

- e. Remove the cable that routes under the flat ribbon cables (**8**).

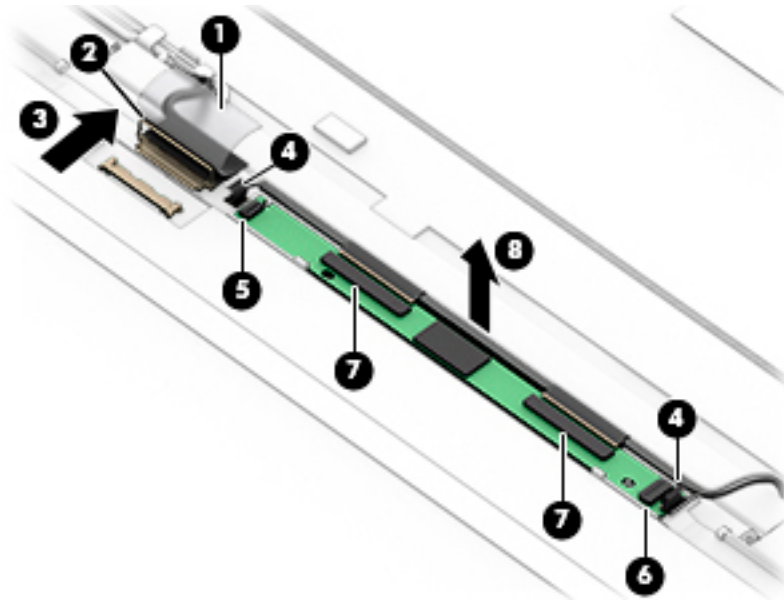

- f. After disconnecting the cables from the touch control board, you can remove the display panel from the display enclosure.
- g. Lift the board up to disengage the adhesive that secures it, and then remove the board from the display.

The touch control board is available using spare part number L29890-001.

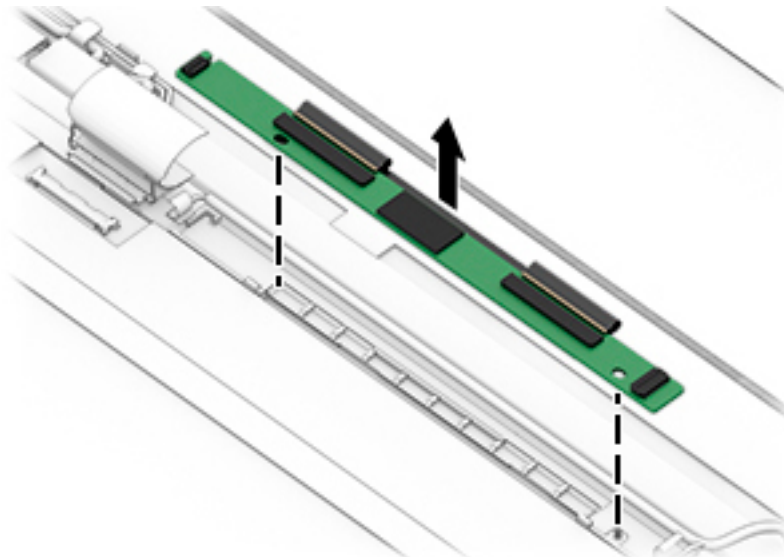

7. If it is necessary to remove the camera module:

HD camera

- a. Position the display assembly with the top edge toward you.
- b. Lift the tape from the connector on the camera module (**1**), and then disconnect the cable (**2**) from the module.

- c. Lift up to disengage the HD camera module from the adhesive that secures it to the display **(3)**.
The HD camera is available using spare part number L28261-001.

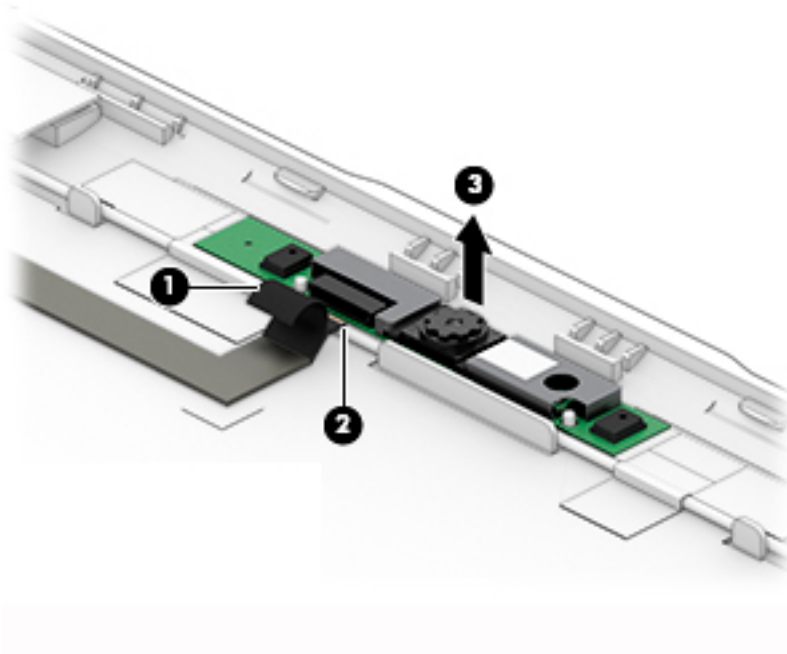

IR camera

- a. Position the display assembly with the top edge toward you.
b. Lift the tape from the connectors on both ends of the camera module **(1)**.
c. Lift up to disengage the IR camera module from the adhesive that secures it to the display **(2)**.
d. Disconnect the cables **(3)** from both ends of the module.
The IR camera is available using spare part number L28260-001.

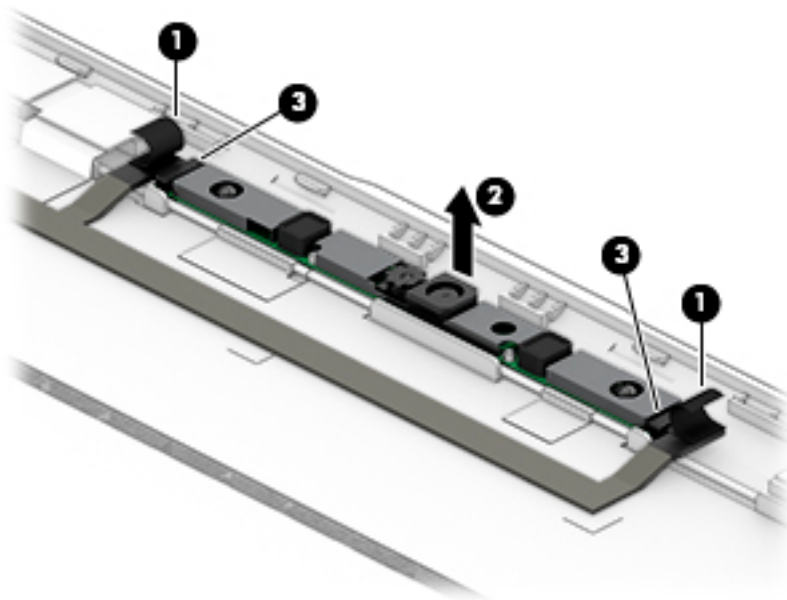

8. If it is necessary to remove the display hinge brackets:
- Remove the eight Phillips M2.0×3.0 screws **(1)** that secure the hinge brackets to the computer.
 - Pulling toward the inside of the display, pull the adhesive tape out from underneath each hinge bracket **(2)**. The tape runs the entire length of the bracket.

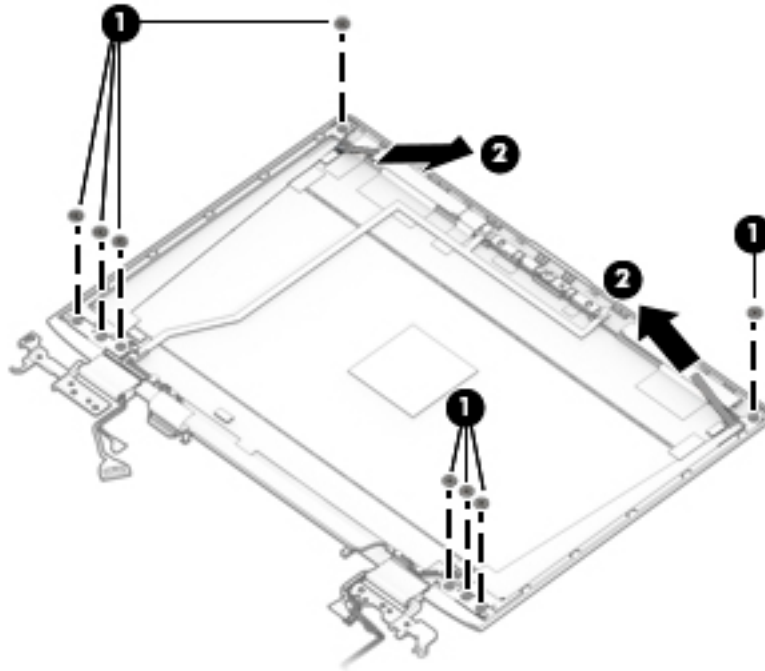

- Rotate the hinges to the closed position **(1)**.

- d. Lift the brackets upward (2), and then pull the brackets free of the cables that extend from each hinge (3).

The display hinge brackets are available using spare part number L28250-001.

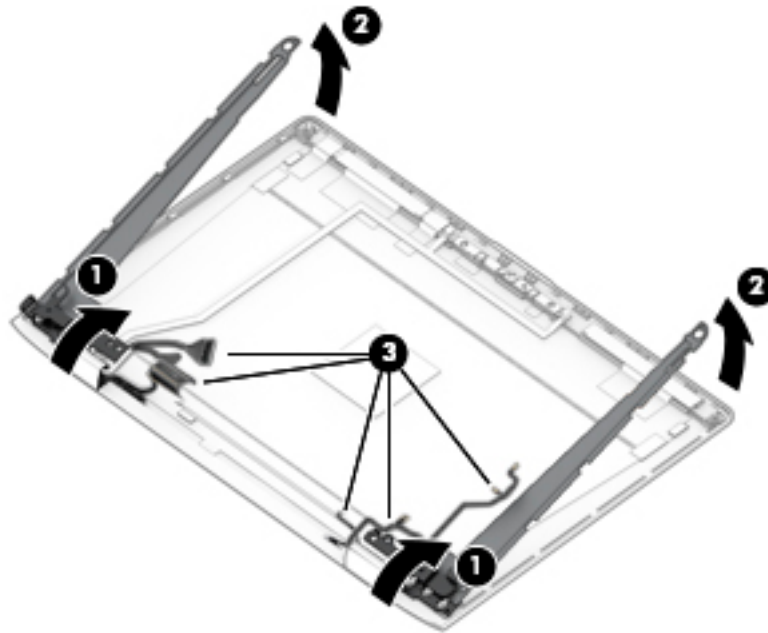

-  **TIP:** When installing hinge brackets, secure the adhesive tape to the display enclosure as shown in the following illustration. Be sure to remove the top adhesive backing before installing the bracket on top of the tape.

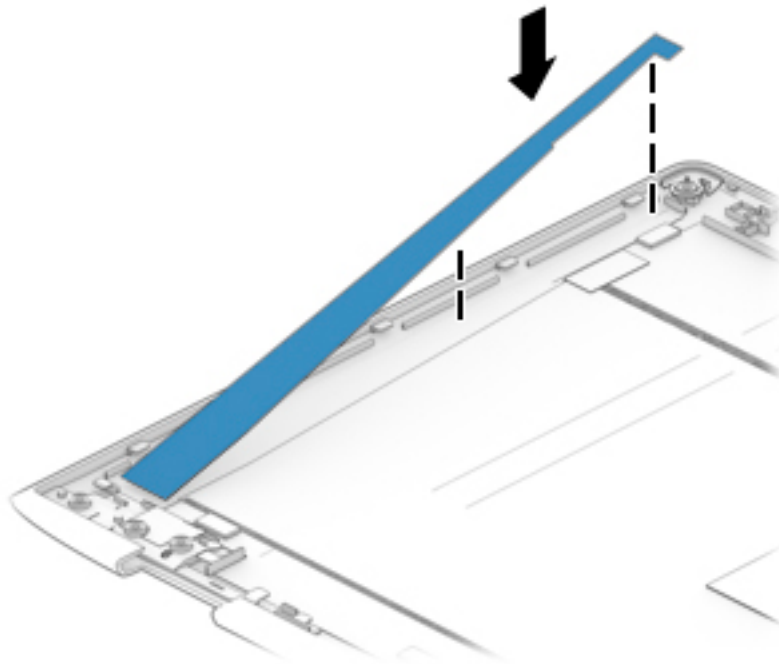

9. If it is necessary to remove the rubber piece from inside of the hinge cover, use a tweezer to pull the rubber piece out on the hinge cover.

The hinge cover rubber pieces are available in the Display Rubber Kit using spare part number L31175-001.



 **TIP:** When replacing the hinge rubber piece, first insert the cables into the hinge covers **(1)**, and then insert the rubber piece into the hinge cover **(2)**.

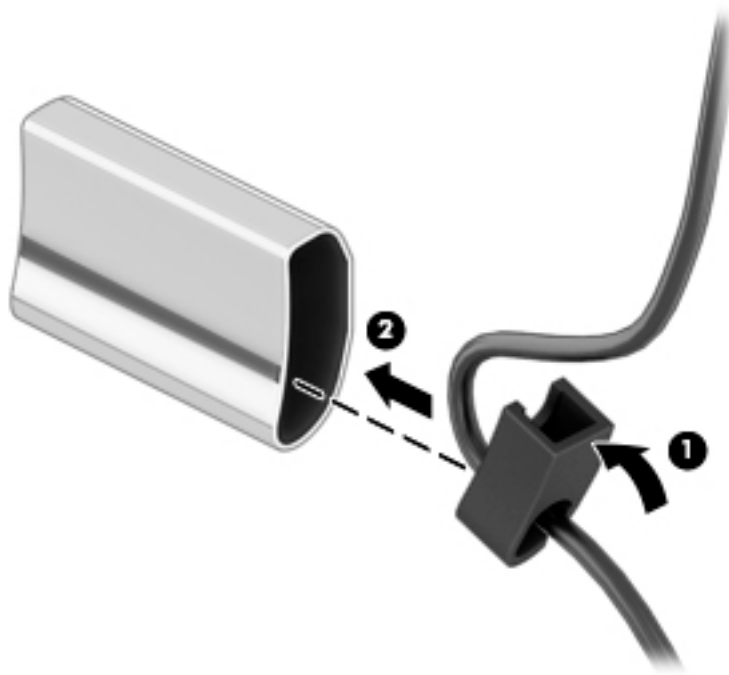

10. If it is necessary to remove the hinge cover, remove the Phillips M2.0×3.0 screw **(1)** from inside of each hinge cover, and then pull the cover off the hinge **(2)**.

The display hinge covers are available using spare part number L29056-001.

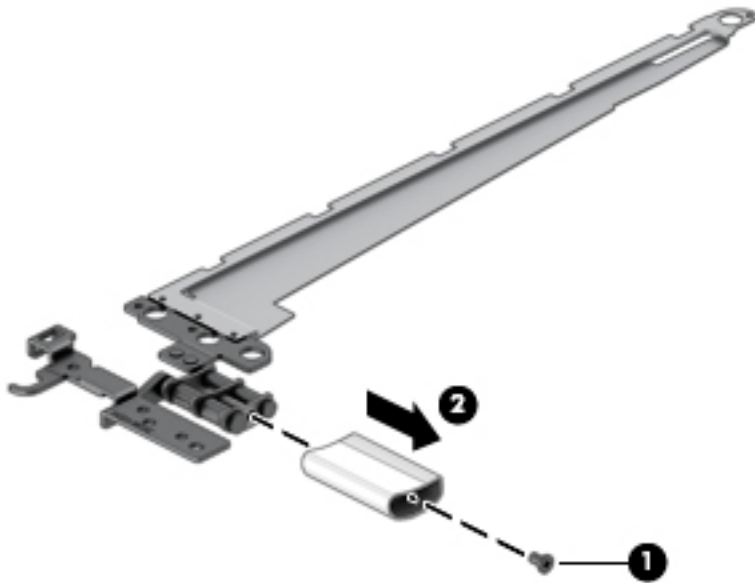

11. If it is necessary to replace the touch control cable, lift the cable off the display enclosure.

The touch control cable is available in the Display Cable Kit using spare part number L31174-001.

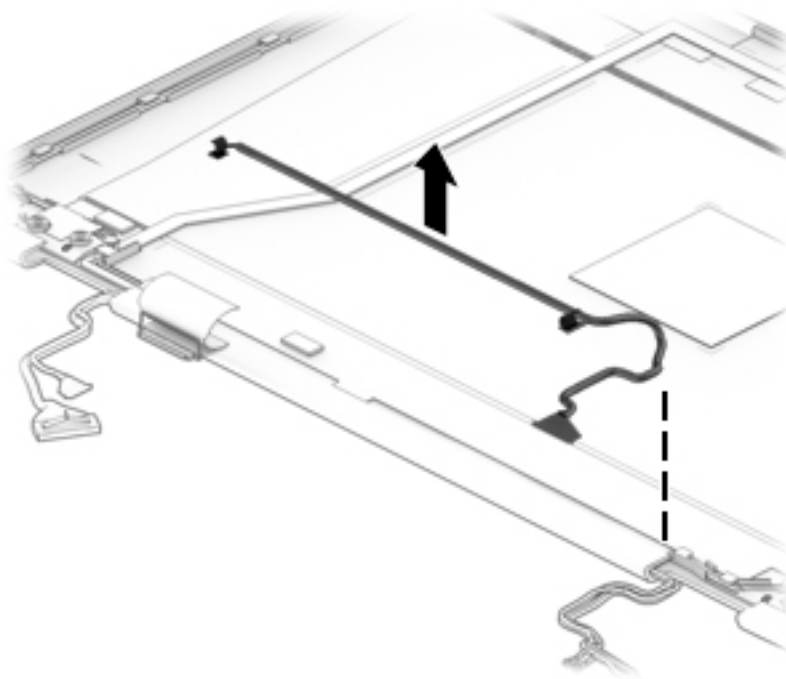

12. If it is necessary to replace the WWAN antennas, peel the antennas from the display enclosure (1), remove the cables from the hinges (2), remove the antenna alignment rubber piece (3), and then lift the cables and antennas from the enclosure (4).

The WWAN antennas are available using spare part number L29055-001.

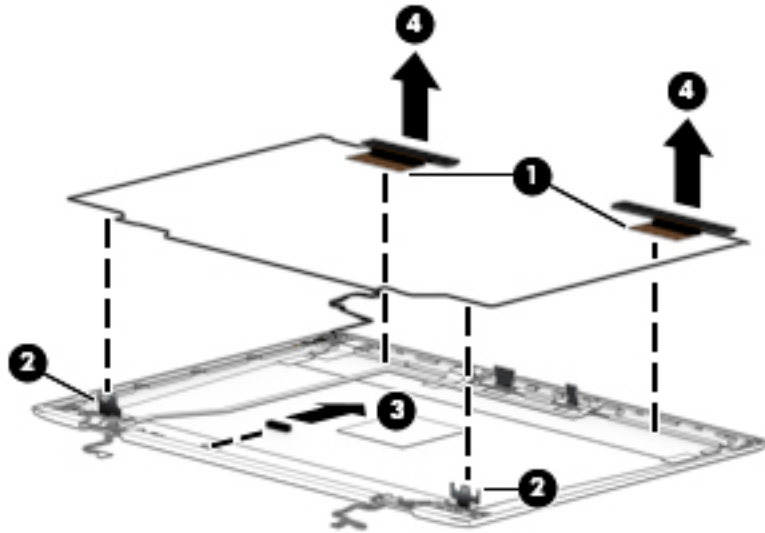

13. When installing WWAN antennas:
 - a. Insert the rubber alignment piece (1) into place with the notch facing the lip in the display enclosure (2). Route the antenna cables (3) around the display hinges (4).

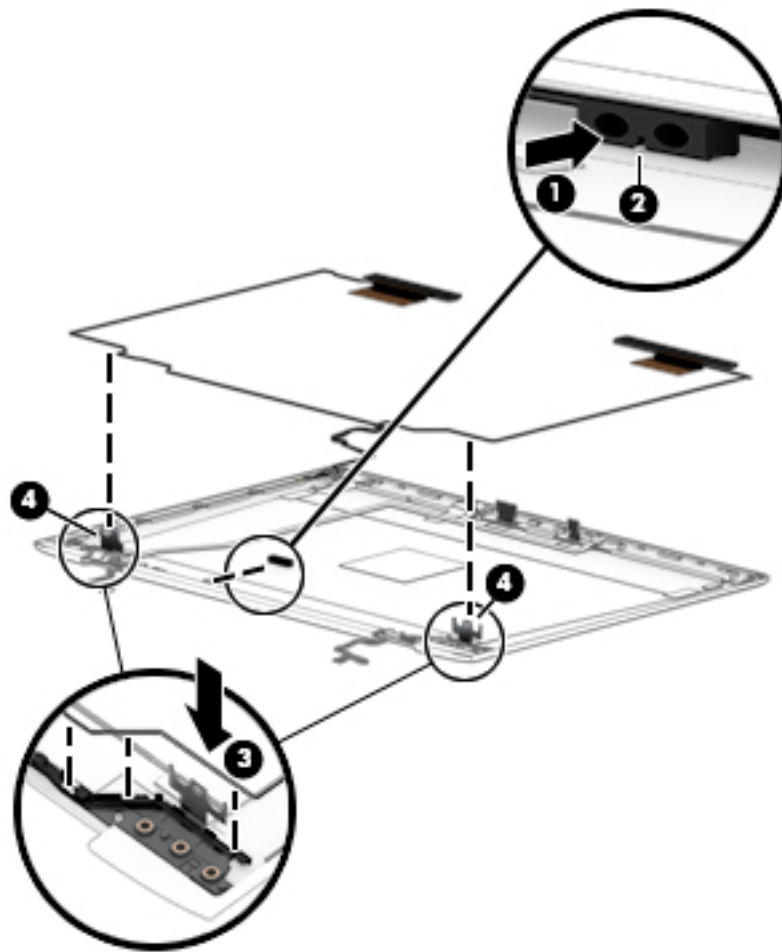

b. Adhere the antennas to the top of the display enclosure.

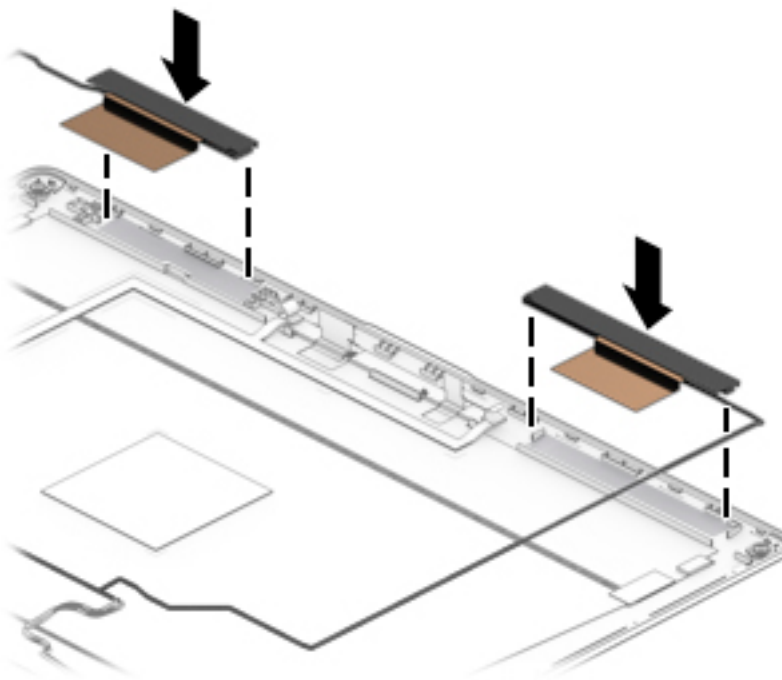

14. If it is necessary to replace the WLAN antennas, peel the antennas from the display enclosure (1), remove the cables from the hinges (2), remove the antenna alignment rubber piece (3), and then lift the cables and antennas from the enclosure (4).

The WLAN antennas are available using spare part number L29054-001.

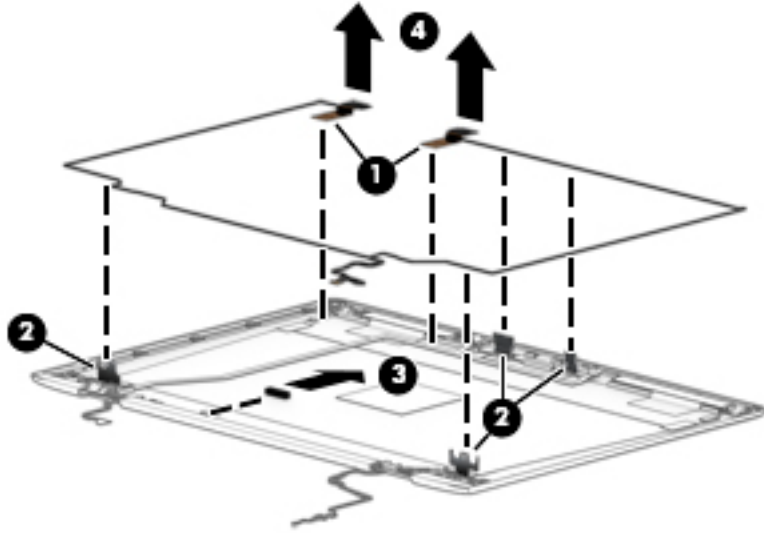

15. When installing WLAN antennas:
 - a. Insert the rubber alignment piece (1) into place with the notch facing the lip in the display enclosure (2). Route the antenna cables (3) around the display hinges (4).

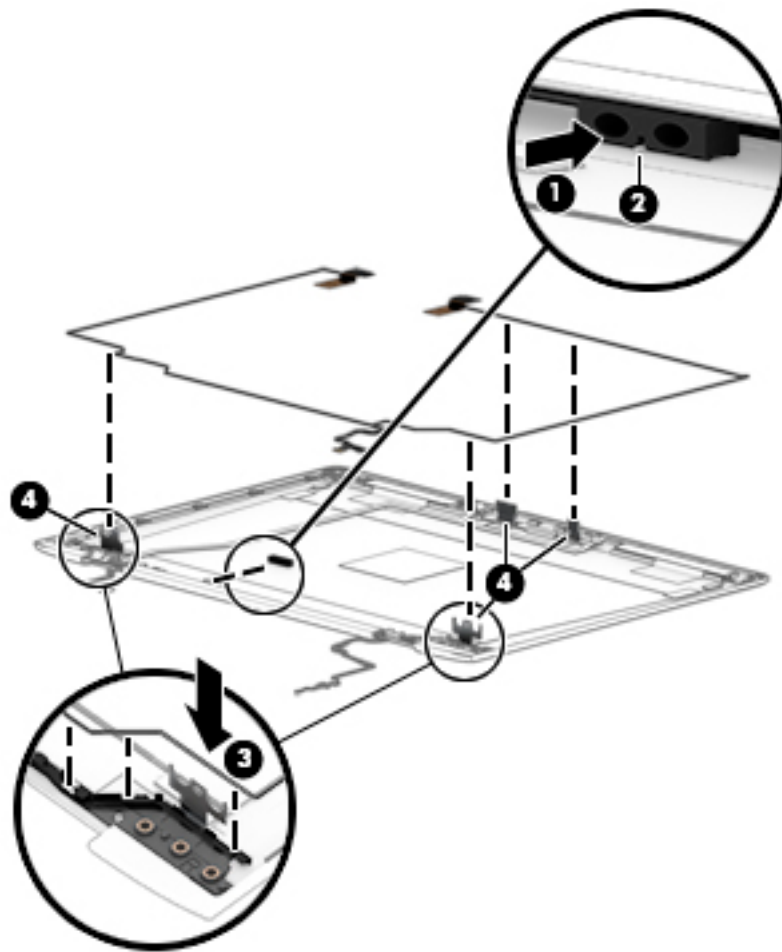

b. Adhere the antennas to the top of the display enclosure.

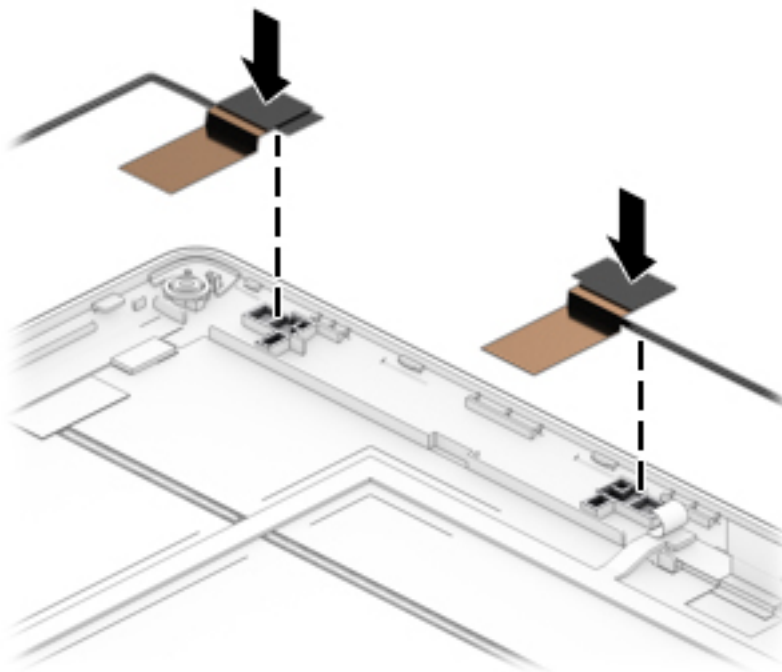

- 16.** If it is necessary to replace the eDP cable, lift the cable from the display enclosure.
The eDP cable is available in the Display Cable Kit using spare part number L31174-001.

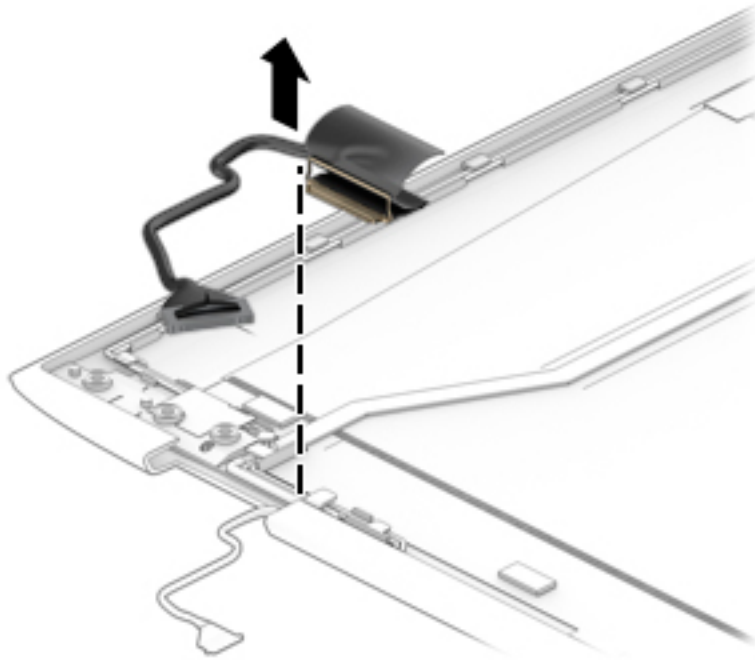

- 17.** If it is necessary to remove or replace the HD camera cable, disconnect the cable from the camera module, and then remove the cable from the display enclosure.
The HD camera cable is available in the Display Cable Kit using spare part number L31174-001.

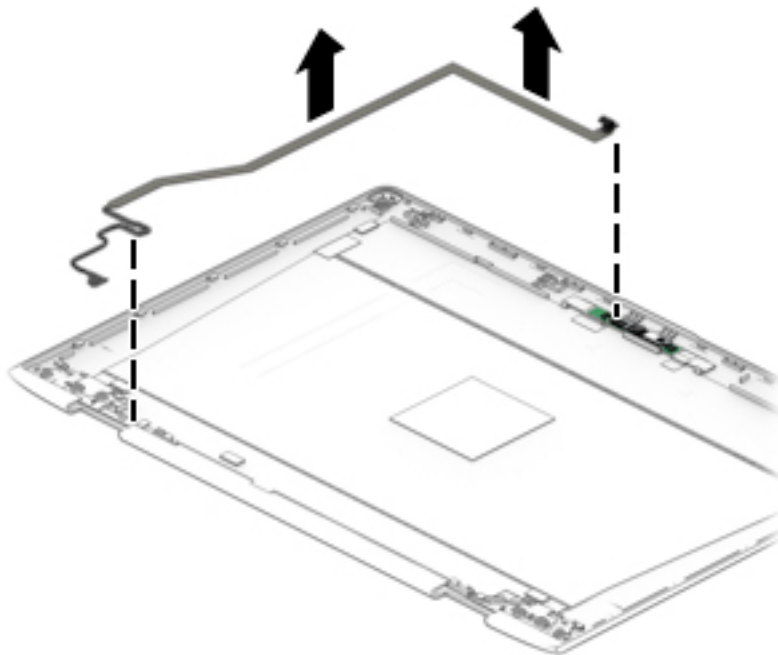

18. If it is necessary to remove or replace the IR camera cable, disconnect the cable from both ends of the camera module, and then remove the cable from the display enclosure.

The IR camera cable is available in the Display Cable Kit using spare part number L31174-001.

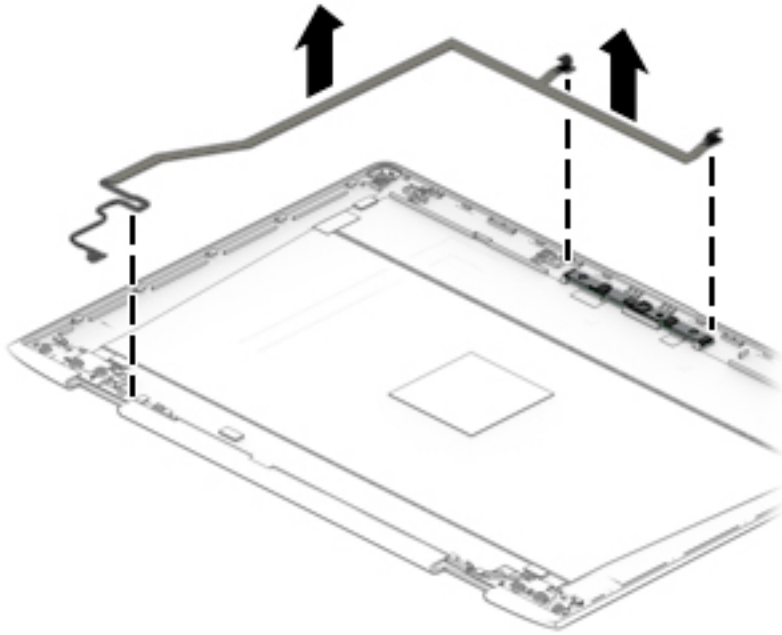

The display enclosure is available using spare part number L28262-001.

Reverse this procedure to reassemble the touch display assembly.

Power button board

Description	Spare part number
Power button board	L28251-001
Power button board cable (included in Cable Kit)	L28263-001

Before removing the power button board, follow these steps:

1. Shut down the computer. If you are unsure whether the computer is off or in Hibernation, turn the computer on, and then shut it down through the operating system.
2. Place the computer in “Battery Safe mode” ([Battery Safe mode on page 31](#)).
3. Disconnect all external devices connected to the computer.
4. Disconnect the power from the computer by first unplugging the power cord from the AC outlet, and then unplugging the AC adapter from the computer.
5. Remove the following components:
 - a. Service door ([Service doors on page 32](#))
 - b. Keyboard ([Keyboard on page 40](#))
 - c. Top cover ([Top cover on page 47](#))
 - d. Battery ([Battery on page 52](#))
 - e. Display assembly ([Display assembly on page 62](#))

Remove the power button board:

1. Disconnect the cable from the ZIF connector on the power button board **(1)**.
2. Remove the Phillips M2.0×4.0 screw **(2)** that secures the board to the computer.

3. Remove the board from the computer (3).

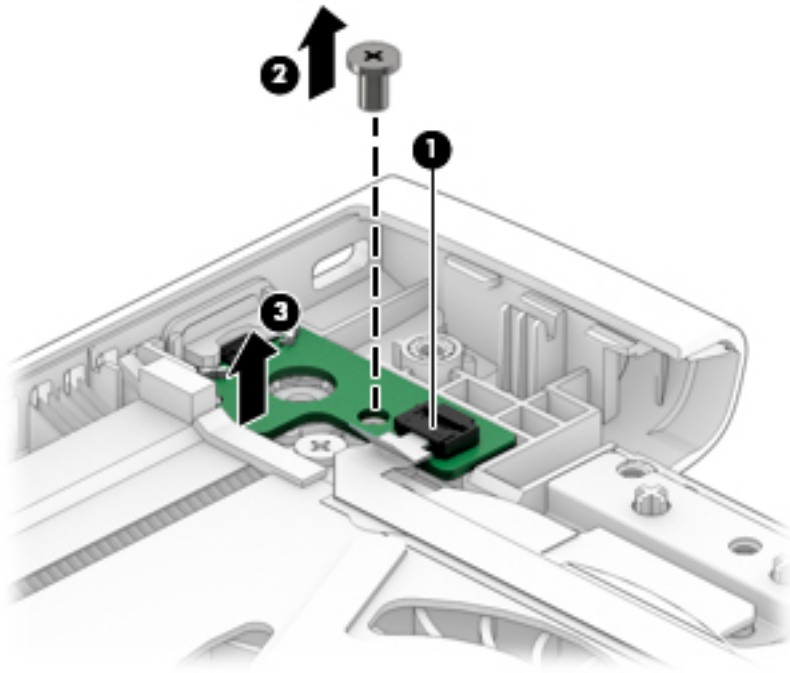

Reverse this procedure to install the power button board.

Power connector cable

Description	Spare part number
Power connector cable	L28264-001

Before removing the power connector cable, follow these steps:

1. Shut down the computer. If you are unsure whether the computer is off or in Hibernation, turn the computer on, and then shut it down through the operating system.
2. Place the computer in “Battery Safe mode” ([Battery Safe mode on page 31](#)).
3. Disconnect all external devices connected to the computer.
4. Disconnect the power from the computer by first unplugging the power cord from the AC outlet, and then unplugging the AC adapter from the computer.
5. Remove the following components:
 - a. Service door ([Service doors on page 32](#)).
 - b. Keyboard ([Keyboard on page 40](#))
 - c. Top cover ([Top cover on page 47](#))
 - d. Battery ([Battery on page 52](#))
 - e. Display assembly ([Display assembly on page 62](#))

Remove the power connector cable:

1. Disconnect the cable from the system board (1).
2. Lift the cable side of the connector upward (2), and then pull the connector (3) out from under the tab (4) to remove it.

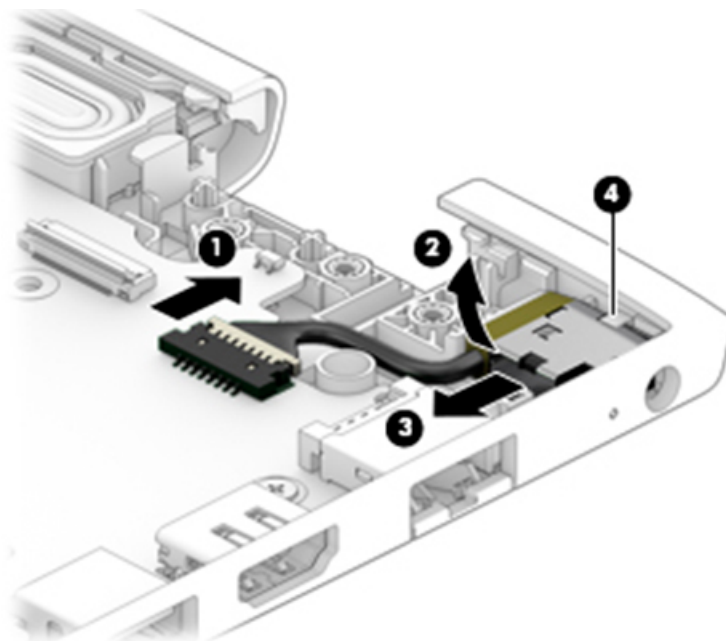

Reverse this procedure to install the power connector cable.

7 Computer Setup (BIOS), TPM, and HP Sure Start

Using Computer Setup

Computer Setup, or Basic Input/Output System (BIOS), controls communication between all the input and output devices on the system (such as disk drives, display, keyboard, mouse, and printer). Computer Setup includes settings for the types of devices installed, the startup sequence of the computer, and the amount of system and extended memory.



NOTE: Use extreme care when making changes in Computer Setup. Errors can prevent the computer from operating properly.

Starting Computer Setup

- ▲ Turn on or restart the computer, and when the HP logo appears, press **f10** to enter Computer Setup.

Using a USB keyboard or USB mouse to start Computer Setup (BIOS)

You can start Computer Setup by using a keyboard or mouse connected to a USB port, but you must first disable FastBoot.

1. Turn on or restart the computer, and when the HP logo appears, press **f9** to enter the Boot Device Options menu.
2. Clear the check box for **Fast Boot**.
3. To save your changes and exit, select the **Save** icon in the lower-right corner of the screen, and then follow the on-screen instructions.

– or –

Select **Main**, select **Save Changes and Exit**, and then press **enter**.

Your changes go into effect when the computer restarts.

Navigating and selecting in Computer Setup

- To select a menu or a menu item, use the **tab** key and the keyboard arrow keys and then press **enter**, or use a pointing device to select the item.
- To scroll up and down, select the up arrow or the down arrow in the upper-right corner of the screen, or use the up arrow key or the down arrow key on the keyboard.
- To close open dialog boxes and return to the main Computer Setup screen, press **esc**, and then follow the on-screen instructions.

To exit Computer Setup menus, choose one of the following methods:

- To exit Computer Setup menus without saving your changes:
Select the **Exit** icon in the lower-right corner of the screen, and then follow the on-screen instructions.
– or –
Select **Main**, select **Ignore Changes and Exit**, and then press [enter](#).
- To save your changes and exit Computer Setup menus:
Select the **Save** icon in the lower-right corner of the screen, and then follow the on-screen instructions.
– or –
Select **Main**, select **Save Changes and Exit**, and then press [enter](#).

Your changes go into effect when the computer restarts.

Restoring factory settings in Computer Setup

 **NOTE:** Restoring defaults will not change the hard drive mode.

To return all settings in Computer Setup to the values that were set at the factory, follow these steps:

1. Start Computer Setup. See [Starting Computer Setup on page 80](#).
2. Select **Main**, and then select **Apply Factory Defaults and Exit**.

 **NOTE:** On select products, the selections may display **Restore Defaults** instead of **Apply Factory Defaults and Exit**.

3. Follow the on-screen instructions.
4. To save your changes and exit, select the **Save** icon in the lower-right corner of the screen, and then follow the on-screen instructions.
– or –
Select **Main**, select **Save Changes and Exit**, and then press [enter](#).

Your changes go into effect when the computer restarts.

 **NOTE:** Your password settings and security settings are not changed when you restore the factory settings.

Updating the BIOS

Updated versions of the BIOS may be available on the HP website.

Most BIOS updates on the HP website are packaged in compressed files called *SoftPaqs*.

Some download packages contain a file named *Readme.txt*, which contains information regarding installing and troubleshooting the file.

Determining the BIOS version

To decide whether you need to update Computer Setup (BIOS), first determine the BIOS version on your computer.

BIOS version information (also known as *ROM date* and *System BIOS*) can be accessed by pressing [fn+esc](#) (if you are already in Windows) or by using Computer Setup.

1. Start Computer Setup. See [Starting Computer Setup on page 80](#).
2. Select **Main**, and then select **System Information**.
3. To exit Computer Setup without saving your changes, select the **Exit** icon in the lower-right corner of the screen, and then follow the on-screen instructions.

– or –

Select **Main**, select **Ignore Changes and Exit**, and then press **enter**.

To check for later BIOS versions, see [Downloading a BIOS update on page 82](#).

Downloading a BIOS update

 **CAUTION:** To reduce the risk of damage to the computer or an unsuccessful installation, download and install a BIOS update only when the computer is connected to reliable external power using the AC adapter. Do not download or install a BIOS update while the computer is running on battery power, docked in an optional docking device, or connected to an optional power source. During the download and installation, follow these instructions:

Do not disconnect power on the computer by unplugging the power cord from the AC outlet.

Do not shut down the computer or initiate Sleep.

Do not insert, remove, connect, or disconnect any device, cable, or cord.

1. Type `support` in the taskbar search box, and then select the HP Support Assistant app.
– or –
Select the question mark icon in the taskbar.
2. Select **Updates**, and then select **Check for updates and messages**.
3. Follow the on-screen instructions.
4. At the download area, follow these steps:
 - a. Identify the most recent BIOS update and compare it to the BIOS version currently installed on your computer. Make a note of the date, name, or other identifier. You may need this information to locate the update later, after it has been downloaded to your hard drive.
 - b. Follow the on-screen instructions to download your selection to the hard drive.
Make a note of the path to the location on your hard drive where the BIOS update is downloaded. You will need to access this path when you are ready to install the update.

 **NOTE:** If you connect your computer to a network, consult the network administrator before installing any software updates, especially system BIOS updates.

BIOS installation procedures vary. Follow any instructions that are displayed on the screen after the download is complete. If no instructions are displayed, follow these steps:

1. Type `file` in the taskbar search box, and then select **File Explorer**.
2. Select your hard drive designation. The hard drive designation is typically Local Disk (C:).
3. Using the hard drive path you recorded earlier, open the folder that contains the update.
4. Double-click the file that has an `.exe` extension (for example, `filename.exe`).
The BIOS installation begins.
5. Complete the installation by following the on-screen instructions.



NOTE: After a message on the screen reports a successful installation, you can delete the downloaded file from your hard drive.

Changing the boot order using the f9 prompt

To dynamically choose a boot device for the current startup sequence, follow these steps:

1. Access the Boot Device Options menu:
 - Turn on or restart the computer, and when the HP logo appears, press **f9** to enter the Boot Device Options menu.
2. Select a boot device, press **enter**, and then follow the on-screen instructions.

TPM BIOS settings (select products only)



IMPORTANT: Before enabling Trusted Platform Module (TPM) functionality on this system, you must ensure that your intended use of TPM complies with relevant local laws, regulations and policies, and approvals or licenses must be obtained if applicable. For any compliance issues arising from your operation/usage of TPM which violates the above mentioned requirement, you shall bear all the liabilities wholly and solely. HP will not be responsible for any related liabilities.

TPM provides additional security for your computer. You can modify the TPM settings in Computer Setup (BIOS).



NOTE: If you change the TPM setting to Hidden, TPM is not visible in the operating system.

To access TPM settings in Computer Setup:

1. Start Computer Setup. See [Starting Computer Setup on page 80](#).
2. Select **Security**, select **TPM Embedded Security**, and then follow the on-screen instructions.

Using HP Sure Start (select products only)

Select computer models are configured with HP Sure Start, a technology that monitors the computer's BIOS for attacks or corruption. If the BIOS becomes corrupted or is attacked, HP Sure Start automatically restores the BIOS to its previously safe state, without user intervention.

HP Sure Start is configured and already enabled so that most users can use the HP Sure Start default configuration. The default configuration can be customized by advanced users.

To access the latest documentation on HP Sure Start, go to <http://www.hp.com/support>. Select **Find your product**, and then follow the on-screen instructions.

8 Using HP PC Hardware Diagnostics

Using HP PC Hardware Diagnostics Windows (select products only)

HP PC Hardware Diagnostics Windows is a Windows-based utility that allows you to run diagnostic tests to determine whether the computer hardware is functioning properly. The tool runs within the Windows operating system in order to diagnose hardware failures.

If HP PC Hardware Diagnostics Windows is not installed on your computer, first you must download and install it. To download HP PC Hardware Diagnostics Windows, see [Downloading HP PC Hardware Diagnostics Windows on page 84](#).

After HP PC Hardware Diagnostics Windows is installed, follow these steps to access it from HP Help and Support or HP Support Assistant.

1. To access HP PC Hardware Diagnostics Windows from HP Help and Support:
 - a. Select the **Start** button, and then select **HP Help and Support**.
 - b. Right-click **HP PC Hardware Diagnostics Windows**, select **More**, and then select **Run as administrator**.

– or –

To access HP PC Hardware Diagnostics Windows from HP Support Assistant:

- a. Type `support` in the taskbar search box, and then select the **HP Support Assistant** app.
 - or –
 - Select the question mark icon in the taskbar.
 - b. Select **Troubleshooting and fixes**.
 - c. Select **Diagnostics**, and then select **HP PC Hardware Diagnostics Windows**.
2. When the tool opens, select the type of diagnostic test you want to run, and then follow the on-screen instructions.

 **NOTE:** If you need to stop a diagnostic test at any time, select **Cancel**.

3. When HP PC Hardware Diagnostics Windows detects a failure that requires hardware replacement, a 24-digit Failure ID code is generated. For assistance in correcting the problem, contact support, and then provide the Failure ID code.

Downloading HP PC Hardware Diagnostics Windows

- The HP PC Hardware Diagnostics Windows download instructions are provided in English only.
- You must use a Windows computer to download this tool because only .exe files are provided.

Downloading the latest HP PC Hardware Diagnostics Windows version

To download HP PC Hardware Diagnostics Windows, follow these steps:

1. Go to <http://www.hp.com/go/techcenter/pcdiags>. The HP PC Diagnostics home page is displayed.
2. In the **HP PC Hardware Diagnostics** section, select **Download**, and then select a location on your computer or a USB flash drive.

The tool is downloaded to the selected location.

Downloading HP Hardware Diagnostics Windows by product name or number (select products only)

 **NOTE:** For some products, it may be necessary to download the software to a USB flash drive by using the product name or number.

To download HP PC Hardware Diagnostics Windows by product name or number, follow these steps:

1. Go to <http://www.hp.com/support>.
2. Select **Get software and drivers**, select your type of product, and then enter the product name or number in the search box that is displayed.
3. In the **HP PC Hardware Diagnostics** section, select **Download**, and then select a location on your computer or a USB flash drive.

The tool is downloaded to the selected location.

Installing HP PC Hardware Diagnostics Windows

To install HP PC Hardware Diagnostics Windows, follow these steps:

- ▲ Navigate to the folder on your computer or the flash drive where the .exe file was downloaded, double-click the .exe file, and then follow the on-screen instructions.

Using HP PC Hardware Diagnostics UEFI

 **NOTE:** For Windows 10 S computers, you must use a Windows computer and a USB flash drive to download and create the HP UEFI support environment because only .exe files are provided. For more information, see [Downloading HP PC Hardware Diagnostics UEFI to a USB flash drive on page 86](#).

HP PC Hardware Diagnostics UEFI (Unified Extensible Firmware Interface) allows you to run diagnostic tests to determine whether the computer hardware is functioning properly. The tool runs outside the operating system so that it can isolate hardware failures from issues that are caused by the operating system or other software components.

If your PC will not boot into Windows, you can use HP PC Hardware Diagnostics UEFI to diagnose hardware issues.

When HP PC Hardware Diagnostics UEFI detects a failure that requires hardware replacement, a 24-digit Failure ID code is generated. For assistance in correcting the problem, contact support, and provide the Failure ID code.

 **NOTE:** To start diagnostics on a convertible computer, your computer must be in notebook mode, and you must use the attached keyboard.

 **NOTE:** If you need to stop a diagnostic test, press `esc`.

Starting HP PC Hardware Diagnostics UEFI

To start HP PC Hardware Diagnostics UEFI, follow these steps:

1. Turn on or restart the computer, and quickly press *esc*.
2. Press *f2*.

The BIOS searches three places for the diagnostic tools, in the following order:

- a. Connected USB flash drive



NOTE: To download the HP PC Hardware Diagnostics UEFI tool to a USB flash drive, see [Downloading the latest HP PC Hardware Diagnostics UEFI version on page 86](#).

- b. Hard drive

- c. BIOS

3. When the diagnostic tool opens, select the type of diagnostic test you want to run, and then follow the on-screen instructions.

Downloading HP PC Hardware Diagnostics UEFI to a USB flash drive

Downloading HP PC Hardware Diagnostics UEFI to a USB flash drive can be useful in the following situations:

- HP PC Hardware Diagnostics UEFI is not included in the preinstall image.
- HP PC Hardware Diagnostics UEFI is not included in the HP Tool partition.
- The hard drive is damaged.



NOTE: The HP PC Hardware Diagnostics UEFI download instructions are provided in English only, and you must use a Windows computer to download and create the HP UEFI support environment because only .exe files are provided.

Downloading the latest HP PC Hardware Diagnostics UEFI version

To download the latest HP PC Hardware Diagnostics UEFI version to a USB flash drive:

1. Go to <http://www.hp.com/go/techcenter/pcdiags>. The HP PC Diagnostics home page is displayed.
2. In the **HP PC Hardware Diagnostics UEFI** section, select **Download UEFI Diagnostics**, and then select **Run**.

Downloading HP PC Hardware Diagnostics UEFI by product name or number (select products only)



NOTE: For some products, it may be necessary to download the software to a USB flash drive by using the product name or number.

To download HP PC Hardware Diagnostics UEFI by product name or number (select products only) to a USB flash drive:

1. Go to <http://www.hp.com/support>.
2. Enter the product name or number, select your computer, and then select your operating system.
3. In the **Diagnostics** section, follow the on-screen instructions to select and download the specific UEFI Diagnostics version for your computer.

Using Remote HP PC Hardware Diagnostics UEFI settings (select products only)

Remote HP PC Hardware Diagnostics UEFI is a firmware (BIOS) feature that downloads HP PC Hardware Diagnostics UEFI to your computer. It can then execute the diagnostics on your computer, and it may upload results to a preconfigured server. For more information on Remote HP PC Hardware Diagnostics UEFI, go to <http://www.hp.com/go/techcenter/pcdiags>, and then select **Find out more**.

Downloading Remote HP PC Hardware Diagnostics UEFI

 **NOTE:** HP Remote PC Hardware Diagnostics UEFI is also available as a Softpaq that can be downloaded to a server.

Downloading the latest Remote HP PC Hardware Diagnostics UEFI version

To download the latest Remote HP PC Hardware Diagnostics UEFI version, follow these steps:

1. Go to <http://www.hp.com/go/techcenter/pcdiags>. The HP PC Diagnostics home page is displayed.
2. In the **HP PC Hardware Diagnostics UEFI** section, select **Download Remote Diagnostics**, and then select **Run**.

Downloading Remote HP PC Hardware Diagnostics UEFI by product name or number

 **NOTE:** For some products, it may be necessary to download the software by using the product name or number.

To download HP Remote PC Hardware Diagnostics UEFI by product name or number, follow these steps:

1. Go to <http://www.hp.com/support>.
2. Select **Get software and drivers**, select your type of product, enter the product name or number in the search box that is displayed, select your computer, and then select your operating system.
3. In the **Diagnostics** section, follow the on-screen instructions to select and download the **Remote UEFI** version for the product.

Customizing Remote HP PC Hardware Diagnostics UEFI settings

Using the Remote HP PC Hardware Diagnostics setting in Computer Setup (BIOS), you can perform the following customizations:

- Set a schedule for running diagnostics unattended. You can also start diagnostics immediately in interactive mode by selecting **Execute Remote HP PC Hardware Diagnostics**.
- Set the location for downloading the diagnostic tools. This feature provides access to the tools from the HP website or from a server that has been preconfigured for use. Your computer does not require the traditional local storage (such as a disk drive or USB flash drive) to run remote diagnostics.
- Set a location for storing the test results. You can also set the user name and password settings used for uploads.
- Display status information about the diagnostics run previously.

To customize Remote HP PC Hardware Diagnostics UEFI settings, follow these steps:

1. Turn on or restart the computer, and when the HP logo appears, press **f10** to enter Computer Setup.
2. Select **Advanced**, and then select **Settings**.

3. Make your customization selections.
4. Select **Main**, and then **Save Changes and Exit** to save your settings.

Your changes take effect when the computer restarts.

9 Backing up, restoring, and recovering

This chapter provides information about the following processes, which are standard procedure for most products:

- **Backing up your personal information**—You can use Windows tools to back up your personal information (see [Using Windows tools on page 89](#)).
- **Creating a restore point**—You can use Windows tools to create a restore point (see [Using Windows tools on page 89](#)).
- **Creating recovery media** (select products only)—You can use HP Recovery Manager or HP Cloud Recovery Download Tool (select products only) to create recovery media (see [Creating HP Recovery media \(select products only\) on page 89](#)).
- **Restoring and recovery**—Windows offers several options for restoring from backup, refreshing the computer, and resetting the computer to its original state (see [Using Windows tools on page 89](#)).
- **Removing the Recovery Partition**—To remove the Recovery partition to reclaim hard drive space (select products only), select the **Remove Recovery Partition** option of HP Recovery Manager. For more information, see [Removing the HP Recovery partition \(select products only\) on page 93](#).

Using Windows tools

 **IMPORTANT:** Windows is the only option that allows you to back up your personal information. Schedule regular backups to avoid information loss.

You can use Windows tools to back up personal information and create system restore points and recovery media, allowing you to restore from backup, refresh the computer, and reset the computer to its original state.

 **NOTE:** If computer storage is 32 GB or less, Microsoft System Restore is disabled by default.

For more information and steps, see the Get Help app.

- ▲ Select the **Start** button, and then select the **Get Help** app.

 **NOTE:** You must be connected to the Internet to access the Get Help app.

Creating HP Recovery media (select products only)

After you have successfully set up the computer, use HP Recovery Manager to create a backup of the HP Recovery partition on the computer. This backup is called HP Recovery media. In cases where the hard drive is corrupted or has been replaced, the HP Recovery media can be used to reinstall the original operating system.

To check for the presence of the Recovery partition in addition to the Windows partition, right-click the **Start** button, select **File Explorer**, and then select **This PC**.

 **NOTE:** If your computer does not list the Recovery partition in addition to the Windows partition, contact support to obtain recovery discs. Go to <http://www.hp.com/support>, select your country or region, and then follow the on-screen instructions.

On select products, you can use the HP Cloud Recovery Download Tool to create HP Recovery media on a bootable USB flash drive. For more information, see [Using the HP Cloud Recovery Download Tool to create recovery media on page 91](#).

Using HP Recovery Manager to create recovery media



NOTE: If you cannot create recovery media yourself, contact support to obtain recovery discs. Go to <http://www.hp.com/support>, select your country or region, and then follow the on-screen instructions.

Before you begin

Before you begin, note the following:

- Only one set of recovery media can be created. Handle these recovery tools carefully, and keep them in a safe place.
- HP Recovery Manager examines the computer and determines the required media storage capacity.
- To create recovery media, use one of the following options:



NOTE: If the computer does not have a recovery partition, HP Recovery Manager displays the Windows Create a Recovery Drive feature. Follow the on-screen instructions to create a recovery image on a blank USB flash drive or hard drive.

- If your computer has an optical drive with DVD writer capability, be sure to use only high-quality blank DVD-R, DVD+R, DVD-R DL, or DVD+R DL discs. Do not use rewritable discs such as CD±RW, DVD±RW, double-layer DVD±RW, or BD-RE (rewritable Blu-ray) discs, which are not compatible with HP Recovery Manager software.
- If your computer does not include an integrated optical drive with DVD writer capability, you can use an external optical drive (purchased separately) to create recovery discs, as described above. If an external optical drive is used, you must connect it directly to a USB port on the computer. It cannot be connected to a USB port on an external device, such as a USB hub.
- To create a recovery flash drive, use a high-quality blank USB flash drive.
- Be sure that the computer is connected to AC power before you begin creating the recovery media.
- The creation process can take an hour or more. Do not interrupt this process.
- If necessary, you can exit the program before you have finished creating all of the recovery media. HP Recovery Manager will finish the current DVD or flash drive. The next time you start HP Recovery Manager, you will be prompted to continue.

Creating the recovery media

To create HP Recovery media using HP Recovery Manager:



IMPORTANT: For a tablet with a detachable keyboard, connect the tablet to the keyboard base before beginning these steps.

1. Type `recovery` in the taskbar search box, and then select **HP Recovery Manager**.
2. Select **Create recovery media**, and then follow the on-screen instructions.

If you need to recover the system, see [Recovering using HP Recovery Manager on page 91](#).

Using the HP Cloud Recovery Download Tool to create recovery media

To create HP Recovery media using the HP Cloud Recovery Download Tool:

1. Go to <http://www.hp.com/support>.
2. Select **Software and Drivers**, and then follow the on-screen instructions.

Restoring and recovery

Restoring and recovery can be performed using one or more of the following options: Windows tools, HP Recovery Manager, or the HP Recovery partition.

 **IMPORTANT:** Not all methods are available on all products.

Restoring, resetting, and refreshing using Windows tools

Windows offers several options for restoring, resetting, and refreshing the computer. For details, see [Using Windows tools on page 89](#).

Restoring using HP Recovery Manager and the HP Recovery partition

You can use HP Recovery Manager and the HP Recovery partition (select products only) to restore the computer to the original factory state:

- **Resolving problems with preinstalled applications or drivers**—To correct a problem with a preinstalled application or driver:
 1. Type `recovery` in the taskbar search box, and then select **HP Recovery Manager**.
 2. Select **Reinstall drivers and/or applications**, and then follow the on-screen instructions.
- **Using System Recovery**—To recover the Windows partition to original factory content, select the **System Recovery** option from the HP Recovery partition (select products only) or use the HP Recovery media. For more information, see [Recovering using HP Recovery Manager on page 91](#). If you have not already created recovery media, see [Creating HP Recovery media \(select products only\) on page 89](#).
- **Using Factory Reset** (select products only)—Restores the computer to its original factory state by deleting all information from the hard drive and recreating the partitions and then reinstalling the operating system and the software that was installed at the factory (select products only). To use the **Factory Reset** option, you must use HP Recovery media. If you have not already created recovery media, see [Creating HP Recovery media \(select products only\) on page 89](#).

 **NOTE:** If you have replaced the hard drive in the computer, you can use the Factory Reset option to install the operating system and the software that was installed at the factory.

Recovering using HP Recovery Manager

You can use HP Recovery Manager software to recover the computer to its original factory state by using the HP Recovery media that you either created or that you obtained from HP, or by using the HP Recovery partition (select products only).

If you have not already created HP Recovery media, see [Creating HP Recovery media \(select products only\) on page 89](#).

 **IMPORTANT:** HP Recovery Manager does not automatically provide backups of your personal data. Before beginning recovery, back up any personal data that you want to retain. See [Using Windows tools on page 89](#).

IMPORTANT: Recovery through HP Recovery Manager should be used as a final attempt to correct computer issues.

 **NOTE:** When you start the recovery process, only the options available for your computer are displayed.

Before you begin, note the following:

- HP Recovery Manager recovers only software that was installed at the factory. For software not provided with this computer, you must either download the software from the manufacturer's website or reinstall the software from the media provided by the manufacturer.
- If the computer hard drive fails, HP Recovery media must be used. This media is created using HP Recovery Manager. See [Creating HP Recovery media \(select products only\) on page 89](#).
- If your computer does not allow the creation of HP Recovery media or if the HP Recovery media does not work, contact support to obtain recovery media. Go to <http://www.hp.com/support>, select your country or region, and then follow the on-screen instructions.

Recovering using the HP Recovery partition (select products only)

The HP Recovery partition allows you to perform a system recovery without recovery discs or a recovery USB flash drive. This type of recovery can be used only if the hard drive is still working.

The HP Recovery partition (select products only) allows System Recovery only.

To start HP Recovery Manager from the HP Recovery partition:

 **IMPORTANT:** For a tablet with a detachable keyboard, connect the tablet to the keyboard base before beginning these steps (select products only).

1. Type `recovery` in the taskbar search box, select **HP Recovery Manager**, and then select **Windows Recovery Environment**.

– or –

For computers or tablets with keyboards attached:

- ▲ Press **f11** while the computer boots, or press and hold **f11** as you press the power button.

For tablets without keyboards:

- ▲ Turn on or restart the tablet, quickly hold down the volume up button, and then select **f11**.

2. Select **Troubleshoot** from the boot options menu.
3. Select **Recovery Manager**, and then follow the on-screen instructions.

 **NOTE:** If your computer does not automatically restart in HP Recovery Manager, change the computer boot order, and then follow the on-screen instructions. See [Changing the computer boot order on page 93](#).

Recovering using HP Recovery media

If your computer does not have an HP Recovery partition or if the hard drive is not working properly, you can use HP Recovery media to recover the original operating system and software programs that were installed at the factory.

- ▲ Insert the HP Recovery media, and then restart the computer.

 **NOTE:** If your computer does not automatically restart in HP Recovery Manager, change the computer boot order, and then follow the on-screen instructions. See [Changing the computer boot order on page 93](#).

Changing the computer boot order

If your computer does not restart in HP Recovery Manager, you can change the computer boot order. This is the order of devices listed in BIOS where the computer looks for startup information. You can change the selection to an optical drive or a USB flash drive, depending on the location of your HP Recovery media.

To change the boot order:

 **IMPORTANT:** For a tablet with a detachable keyboard, connect the tablet to the keyboard base before beginning these steps.

1. Insert the HP Recovery media.
2. Access the system **Startup** menu.

For computers or tablets with keyboards attached:

- ▲ Turn on or restart the computer or tablet, quickly press **esc**, and then press **f9** for boot options.

For tablets without keyboards:

- ▲ Turn on or restart the tablet, quickly hold down the volume up button, and then select **f9**.

– or –

Turn on or restart the tablet, quickly hold down the volume down button, and then select **f9**.

3. Select the optical drive or USB flash drive from which you want to boot, and then follow the on-screen instructions.

Removing the HP Recovery partition (select products only)

HP Recovery Manager software allows you to remove the HP Recovery partition (select products only) to free up hard drive space.

 **IMPORTANT:** After you remove the HP Recovery partition, you will not be able to perform System Recovery or create HP Recovery media. Before removing the Recovery partition, create HP Recovery media. See [Creating HP Recovery media \(select products only\) on page 89](#).

Follow these steps to remove the HP Recovery partition:

1. Type `recovery` in the taskbar search box, and then select **HP Recovery Manager**.
2. Select **Remove Recovery Partition**, and then follow the on-screen instructions.

10 Specifications

Computer specifications

	Metric	U.S.
Dimensions		
Depth	232.0 mm	9.13 in
Width	330.0 mm	12.99 in
Height	19.9 mm	0.78 in
Weight		
1 DIMM, WLAN, RGB webcam, no FPR, no Bluetooth, no WWAN, touch, M.2 SSD, UMA, non-backlight KB	1.72 kg	3.8 lbs
Input power		
Operating voltage	19.0 V dc @ 4.74 A – 90 W or 18.5 V dc @ 3.5 A - 65 W	
Operating current	4.74 A or 3.5 A	
Temperature		
Operating (not writing to optical disc)	0°C to 35°C	32°F to 95°F
Operating (writing to optical disc)	5°C to 35°C	41°F to 95°F
Nonoperating	-20°C to 60°C	-4°F to 140°F
Relative humidity		
Operating	10% to 90%	
Nonoperating	5% to 95%	
Maximum altitude (unpressurized)		
Operating (14.7 to 10.1 psia)	-15 m to 3,048 m	50 ft to 10,000 ft
Nonoperating (14.7 to 4.4 psia)	-15 m to 12,192 m	-50 ft to 40,000 ft
NOTE: Applicable product safety standards specify thermal limits for plastic surfaces. The computer operates well within this range of temperatures.		

35.6-cm (14.0-in) display specifications

	Metric	U.S.
Active diagonal size	35.6-cm	14.0-in
Resolution	FHD: 1920x1080	
Surface treatment	Anti-glare	
Panel Width	3.0 mm	
Brightness	220 nits or 400 nits	
Viewing angle	UWVA	
Backlight	LED	
Aspect ratio	16:9	

Solid-state drive specifications

	128-GB*	256-GB*	512-GB*
Height	1.0 mm	1.0 mm	1.0 mm
Length	50.8 mm	50.8 mm	50.8 mm
Width	28.9 mm	28.9 mm	28.9 mm
Weight	< 10 g	< 10 g	< 10 g
Transfer rate			
Sequential read	up to 2150 MB/sec	up to 2150 MB/sec	up to 2150 MB/sec
Random read	Up to 300,000 IOPs	Up to 300,000 IOPs	Up to 300,000 IOPs
Sequential write	up to 1260 MB/sec	up to 1550 MB/sec	up to 1550 MB/sec
Random write	Up to 100,000 IOPs	Up to 100,000 IOPs	Up to 100,000 IOPs
Interface type	SATA-3	PCIe	PCIe
Ready time, maximum (to not busy)	1.0 ms	< 1.0 ms	< 1.0 ms
Access times, logical	0.1 ms	0.1 ms	0.1 ms
Total logical sectors	234,441,648	468,883,296	1,000,215,216
Operating temperature	0°C to 70°C (32°F to 158°F)		

*1 GB = 1 billion bytes when referring to hard drive storage capacity. Actual accessible capacity is less. Actual drive specifications may differ slightly.

NOTE: Certain restrictions and exclusions apply. Contact technical support for details.

11 Statement of memory volatility

The purpose of this chapter is to provide general information regarding nonvolatile memory in HP Business computers. This chapter also provides general instructions for restoring nonvolatile memory that can contain personal data after the system has been powered off and the hard drive has been removed.

HP Business computer products that use Intel®-based or AMD®-based system boards contain volatile DDR memory. The amount of nonvolatile memory present in the system depends upon the system configuration. Intel-based and AMD-based system boards contain nonvolatile memory subcomponents as originally shipped from HP, assuming that no subsequent modifications have been made to the system and assuming that no applications, features, or functionality have been added to or installed on the system.

Following system shutdown and removal of all power sources from an HP Business computer system, personal data can remain on volatile system memory (DIMMs) for a finite period of time and will also remain in nonvolatile memory. Use the steps below to remove personal data from the computer, including the nonvolatile memory found in Intel-based and AMD-based system boards.

 **NOTE:** If your tablet has a keyboard base, connect to the keyboard base before beginning steps in this chapter.

Current BIOS steps

1. Follow steps (a) through (l) below to restore the nonvolatile memory that can contain personal data. Restoring or reprogramming nonvolatile memory that does not store personal data is neither necessary nor recommended.
 - a. Turn on or restart the computer, and then press **esc** while the “Press the ESC key for Startup Menu” message is displayed at the bottom of the screen.

 **NOTE:** If the system has a BIOS administrator password, enter the password at the prompt.
 - b. Select **Main**, select **Apply Factory Defaults and Exit**, and then select **Yes** to load defaults.
The computer will reboot.
 - c. During the reboot, press **esc** while the “Press the ESC key for Startup Menu” message is displayed at the bottom of the screen.

 **NOTE:** If the system has a BIOS administrator password, enter the password at the prompt.
 - d. Select the **Security** menu, select **Restore Security Settings to Factory Defaults**, and then select **Yes** to restore security level defaults.
The computer will reboot.
 - e. During the reboot, press **esc** while the “Press the ESC key for Startup Menu” message is displayed at the bottom of the screen.

 **NOTE:** If the system has a BIOS administrator password, enter the password at the prompt.
 - f. If an asset or ownership tag is set, select the **Security** menu and scroll down to the **Utilities** menu. Select **System IDs**, and then select **Asset Tracking Number**. Clear the tag, and then make the selection to return to the prior menu.

- g. If a DriveLock password is set, select the **Security** menu, and scroll down to **Hard Drive Utilities** under the **Utilities** menu. Select **Hard Drive Utilities**, select **DriveLock**, then uncheck the checkbox for **DriveLock password on restart**. Select **OK** to proceed.
- h. Select the **Main** menu, and then select **Reset BIOS Security to factory default**. Click **Yes** at the warning message.
The computer will reboot.
- i. During the reboot, press **esc** while the “Press the ESC key for Startup Menu” message is displayed at the bottom of the screen.



NOTE: If the system has a BIOS administrator password, enter the password at the prompt.

- j. Select the **Main** menu, select **Apply Factory Defaults and Exit**, select **Yes** to save changes and exit, and then select **Shutdown**.
 - k. Reboot the system. If the system has a Trusted Platform Module (TPM) and/or fingerprint reader, one or two prompts will appear—one to clear the TPM and the other to Reset Fingerprint Sensor; press or tap **F1** to accept or **F2** to reject.
 - l. Remove all power and system batteries for at least 24 hours.
2. Complete one of the following:
- Remove and retain the storage drive.
 - or –
 - Clear the drive contents by using a third party utility designed to erase data from an SSD.
 - or –
 - Clear the contents of the drive by using the following BIOS Setup Secure Erase command option steps:



IMPORTANT: If you clear data using Secure Erase, it cannot be recovered.

- a. Turn on or restart the computer, and then press **esc** while the “Press the ESC key for Startup Menu” message is displayed at the bottom of the screen.
- b. Select the **Security** menu and scroll down to the **Utilities** menu.
- c. Select **Hard Drive Utilities**.
- d. Under **Utilities**, select **Secure Erase**, select the hard drive storing the data you want to clear, and then follow the on-screen instructions to continue.

Nonvolatile memory usage

Nonvolatile Memory Type	Amount (Size)	Does this memory store customer data?	Does this memory retain data when power is removed?	What is the purpose of this memory?	How is data input into this memory?	How is this memory write-protected?
HP Sure Start flash (select models only)	8 MBytes	No	Yes	Provides protected backup of critical System BIOS code, EC firmware, and critical computer configuration data for select platforms that support HP Sure Start. For more information, see Using HP Sure Start (select models only) on page 102 .	Data cannot be written to this device via the host processor. The content is managed solely by the HP Sure Start Embedded Controller.	This memory is protected by the HP Sure Start Embedded Controller.
Real Time Clock (RTC) battery backed-up CMOS configuration memory	256 Bytes	No	Yes	Stores system date and time and noncritical data.	RTC battery backed-up CMOS is programmed using the Computer Setup (BIOS), or changing the Microsoft Windows date & time.	This memory is not write-protected.
Controller (NIC) EEPROM	64 KBytes (not customer accessible)	No	Yes	Stores NIC configuration and NIC firmware.	NIC EEPROM is programmed using a utility from the NIC vendor that can be run from DOS.	A utility is required to write data to this memory and is available from the NIC vendor. Writing data to this ROM in an inappropriate manner will render the NIC non-functional.
DIMM Serial Presence Detect (SPD) configuration data	256 Bytes per memory module, 128 Bytes programmable (not customer accessible)	No	Yes	Stores memory module information.	DIMM SPD is programmed by the memory vendor.	Data cannot be written to this memory when the module is installed in a computer. The specific write-protection method varies by memory vendor.
System BIOS	9 MBytes	Yes	Yes	Stores system BIOS code and computer configuration data.	System BIOS code is programmed at the factory. Code is updated when the system BIOS is updated. Configuration data and settings are input using the Computer Setup (BIOS) or a custom utility.	NOTE: Writing data to this ROM in an inappropriate manner can render the computer non-functional. A utility is required for writing data to this memory and is available on the HP website; go to http://www.hp.com/support . Select Find your

Nonvolatile Memory Type	Amount (Size)	Does this memory store customer data?	Does this memory retain data when power is removed?	What is the purpose of this memory?	How is data input into this memory?	How is this memory write-protected?
Intel Management Engine Firmware (present only in select Elite or Z models. For more information, go to http://www.hp.com/support . Select Find your product , and then follow the on-screen instructions.)	1.5 MBytes or 7 MBytes	Yes	Yes	Stores Management Engine Code, Settings, Provisioning Data and iAMT third-party data store.	Management Engine Code is programmed at the factory. Code is updated via Intel secure firmware update utility. Unique Provisioning Data can be entered at the factory or by an administrator using the Management Engine (MEBx) setup utility. The third party data store contents can be populated by a remote management console or local applications that have been registered by an administrator to have access to the space.	product , and then follow the on-screen instructions. The Intel chipset is configured to enforce hardware protection to block all direct read/write access to this area. An Intel utility is required for updating the firmware. Only firmware updates digitally signed by Intel can be applied using this utility.
Bluetooth flash (select products only)	2 Mbit	No	Yes	Stores Bluetooth configuration and firmware.	Bluetooth flash is programmed at the factory. Tools for writing data to this memory are not publicly available but can be obtained from the silicon vendor.	A utility is required for writing data to this memory and is made available through newer versions of the driver whenever the flash requires an upgrade.
802.11 WLAN EEPROM	4 Kbit to 8 Kbit	No	Yes	Stores configuration and calibration data.	802.11 WLAN EEPROM is programmed at the factory. Tools for writing data to this memory are not made public.	A utility is required for writing data to this memory and is typically not made available to the public unless a firmware upgrade is necessary to address a unique issue.
Webcam (select products only)	64 Kbit	No	Yes	Stores webcam configuration and firmware.	Webcam memory is programmed using a utility from the device manufacturer that can be run from Windows.	A utility is required for writing data to this memory and is typically not made available to the public unless a firmware upgrade is necessary to address a unique issue.
Fingerprint reader (select products only)	512 KByte flash	Yes	Yes	Stores fingerprint templates.	Fingerprint reader memory is programmed by user enrollment in HP ProtectTools Security Manager.	Only a digitally signed application can make the call to write to the flash.

Questions and answers

1. How can the BIOS settings be restored (returned to factory settings)?



IMPORTANT: Restore defaults does not securely erase any data on your hard drive. See question and answer 6 for steps to securely erase data.

Restore defaults does not reset the Custom Secure Boot keys. See question and answer 7 for information about resetting the keys.

- a. Turn on or restart the computer, and then press **esc** while the “Press the ESC key for Startup Menu” message is displayed at the bottom of the screen.
- b. Select **Main**, and then select **Apply Factory Defaults and Exit**.
- c. Follow the on-screen instructions.
- d. Select **Main**, select **Save Changes and Exit**, and then follow the on-screen instructions.

2. What is a UEFI BIOS, and how is it different from a legacy BIOS?

The Unified Extensible Firmware Interface (UEFI) BIOS is an industry-standard software interface between the platform firmware and an operating system (OS). It is a replacement for the older BIOS architecture, but supports much of the legacy BIOS functionality.

Like the legacy BIOS, the UEFI BIOS provides an interface to display the system information and configuration settings and to change the configuration of your computer before an OS is loaded. BIOS provides a secure run-time environment that supports a Graphic User Interface (GUI). In this environment, you can use either a pointing device (Touchscreen, TouchPad, pointing stick, or USB mouse) or the keyboard to navigate and make menu and configuration selections. The UEFI BIOS also contains basic system diagnostics.

The UEFI BIOS provides functionality beyond that of the legacy BIOS. In addition, the UEFI BIOS works to initialize the computer’s hardware before loading and executing the OS; the run-time environment allows the loading and execution of software programs from storage devices to provide more functionality, such as advanced hardware diagnostics (with the ability to display more detailed system information) and advanced firmware management and recovery software.

HP has provided options in Computer Setup (BIOS) to allow you to run in legacy BIOS, if required by the operating system. Examples of this requirement would be if you upgrade or downgrade the OS.

3. Where does the UEFI BIOS reside?

The UEFI BIOS resides on a flash memory chip. A utility is required to write to the chip.

4. What kind of configuration data is stored on the DIMM Serial Presence Detect (SPD) memory module? How would this data be written?

The DIMM SPD memory contains information about the memory module, such as size, serial number, data width, speed/timing, voltage, and thermal information. This information is written by the module manufacturer and stored on an EEPROM. This EEPROM cannot be written to when the memory module is installed in a computer. Third-party tools do exist that can write to the EEPROM when the memory module is not installed in a computer. Various third-party tools are available to read SPD memory.

5. What is meant by “Restore the nonvolatile memory found in Intel-based system boards”?

This message relates to clearing the Real Time Clock (RTC) CMOS memory that contains computer configuration data.

6. How can the BIOS security be reset to factory defaults and data erased?

 **IMPORTANT:** Resetting will result in the loss of information.

These steps will not reset Custom Secure Boot Keys. See question and answer 7 for information about resetting the keys.

- a. Turn on or restart the computer, and then press **esc** while the “Press the ESC key for Startup Menu” message is displayed at the bottom of the screen.
- b. Select **Main**, and then select **Reset Security to Factory Defaults**.
- c. Follow the on-screen instructions.
- d. Select **Main**, select **Save Changes and Exit**, and then follow the on-screen instructions.

7. How can the Custom Secure Boot Keys be reset?

Secure Boot is a feature to ensure that only authenticated code can start on a platform. If you enabled Secure Boot and created Custom Secure Boot Keys, simply disabling Secure Boot will not clear the keys. You must also select to clear the Custom Secure Boot Keys. Use the same Secure Boot access procedure you used to create the Custom Secure Boot Keys, but make the selection to clear or delete all Secure Boot Keys.

- a. Turn on or restart the computer, and then press **esc** while the “Press the ESC key for Startup Menu” message is displayed at the bottom of the screen.
- b. Select the **Security** menu, select **Secure Boot Configuration**, and then follow the on-screen instructions.
- c. At the **Secure Boot Configuration** window, select **Secure Boot**, select **Clear Secure Boot Keys**, and then follow the on-screen instructions to continue.

Using HP Sure Start (select models only)

Select computer models are configured with HP Sure Start, a technology that continuously monitors your computer's BIOS for attacks or corruption. If the BIOS becomes corrupted or is attacked, HP Sure Start restores the BIOS to its previously safe state, without user intervention. Those select computer models ship with HP Sure Start configured and enabled. HP Sure Start is configured and already enabled so that most users can use the HP Sure Start default configuration. The default configuration can be customized by advanced users.

To access the latest documentation on HP Sure Start, go to <http://www.hp.com/support>. Select **Find your product**, and then follow the on-screen instructions.

12 Power cord set requirements

The wide-range input feature of the computer permits it to operate from any line voltage from 100 to 120 volts ac, or from 220 to 240 volts ac.

The 3-conductor power cord set included with the computer meets the requirements for use in the country or region where the equipment is purchased.

Power cord sets for use in other countries and regions must meet the requirements of the country or region where the computer is used.

Requirements for all countries and regions

The following requirements are applicable to all countries and regions:

- The length of the power cord set must be at least **1.5 m** (5.0 ft) and no more than **2.0 m** (6.5 ft).
- All power cord sets must be approved by an acceptable accredited agency responsible for evaluation in the country or region where the power cord set will be used.
- The power cord sets must have a minimum current capacity of 10 A and a nominal voltage rating of 125 or 250 V ac, as required by the power system of each country or region.
- The appliance coupler must meet the mechanical configuration of an EN 60 320/IEC 320 Standard Sheet C13 connector for mating with the appliance inlet on the back of the computer.

Requirements for specific countries and regions

Country/region	Accredited agency	Applicable note number
Argentina	IRAM	1
Australia	SAA	1
Austria	OVE	1
Belgium	CEBEC	1
Brazil	ABNT	1
Canada	CSA	2
Chile	IMQ	1
Denmark	DEMKO	1
Finland	FIMKO	1
France	UTE	1
Germany	VDE	1
India	ISI	1
Israel	SII	1
Italy	IMQ	1

Country/region	Accredited agency	Applicable note number
Japan	JIS	3
The Netherlands	KEMA	1
New Zealand	SANZ	1
Norway	NEMKO	1
The People's Republic of China	CCC	4
Saudi Arabia	SASO	7
Singapore	PSB	1
South Africa	SABS	1
South Korea	KTL	5
Sweden	SEMKO	1
Switzerland	SEV	1
Taiwan	BSMI	6
Thailand	TISI	1
The United Kingdom	ASTA	1
The United States	UL	2

1. The flexible cord must be Type H05VV-F, 3-conductor, 0.75mm² conductor size. Power cord set fittings (appliance coupler and wall plug) must bear the certification mark of the agency responsible for evaluation in the country or region where it will be used.
2. The flexible cord must be Type SVT/SJT or equivalent, No. 18 AWG, 3-conductor. The wall plug must be a two-pole grounding type with a NEMA 5-15P (15 A, 125 V ac) or NEMA 6-15P (15 A, 250 V ac) configuration. CSA or C-UL mark. UL file number must be on each element.
3. The appliance coupler, flexible cord, and wall plug must bear a "T" mark and registration number in accordance with the Japanese Dentori Law. The flexible cord must be Type VCTF, 3-conductor, 0.75mm² or 1.25mm² conductor size. The wall plug must be a two-pole grounding type with a Japanese Industrial Standard C8303 (7 A, 125 V ac) configuration.
4. The flexible cord must be Type RVV, 3-conductor, 0.75mm² conductor size. Power cord set fittings (appliance coupler and wall plug) must bear the CCC certification mark.
5. The flexible cord must be Type H05VV-F 3X0.75mm² conductor size. KTL logo and individual approval number must be on each element. Corset approval number and logo must be printed on a flag label.
6. The flexible cord must be Type HVCTF 3X1.25mm² conductor size. Power cord set fittings (appliance coupler, cable, and wall plug) must bear the BSMI certification mark.
7. For 127 V ac, the flexible cord must be Type SVT or SJT 3 x 18 AWG, with plug NEMA 5-15P (15 A, 125 V ac), with UL and CSA or C-UL marks. For 240 V ac, the flexible cord must be Type H05VV-F 3X0.75/1.00mm² conductor size, with plug BS 1363/A with BSI or ASTA marks.

13 Recycling

When a non-rechargeable or rechargeable battery has reached the end of its useful life, do not dispose of the battery in general household waste. Follow the local laws and regulations in your area for battery disposal.

HP encourages customers to recycle used electronic hardware, HP original print cartridges, and rechargeable batteries. For more information about recycling programs, see the HP Web site at <http://www.hp.com/recycle>.

Index

- A**
- AC adapter, spare part numbers 26
- action keys 14
 - identifying 14
 - keyboard backlight 14
 - mute 14
 - screen brightness 14
 - speaker volume 14
 - switch screen image 14
 - using 14
 - wireless 14
- antennas
 - disconnecting 35
- audio
 - adjusting volume 14
- audio, product description 2
- audio-out (headphone)/audio-in (microphone) combo jack, identifying 8
- B**
- backup, creating 89
- backups 89
- base enclosure, spare part number 20
- battery
 - removing 52
 - spare part number 19, 52
- battery light 6
- BIOS
 - determining version 81
 - downloading an update 82
 - updating 81
- Bluetooth card
 - spare part number 35
- Bluetooth label 17
- boot order
 - changing using the f9 prompt 83
- boot order, changing 93
- bottom 17
- Bracket Kit
 - contents 25
 - spare part number 25
- buttons
 - power 7
- C**
- Cable Kit
 - contents 22, 23
 - spare part number 22, 23
- cables, service considerations 27
- camera 9
 - identifying 9
 - product description 2
- camera cable
 - spare part number 22
- camera light, identifying 9
- camera module
 - spare part number 21
- camera/microphone cable
 - removing 45
- camera/microphone module
 - removing 44, 65
- caps lock light, identifying 11
- components
 - bottom 15
 - display 9
 - keyboard area 10
 - left side 7
 - right side 6
- Computer Setup
 - navigating and selecting 80
 - restoring factory settings 81
 - using a USB keyboard or USB mouse to start Computer Setup 80
- computer setup 80
- computer specifications 94
- connector, power 7
- connectors, service considerations 27
- control zone 10
- D**
- diskette drive
 - precautions 28
- display assembly
 - removal 62
 - spare part numbers 21, 62
- display bezel
 - removing 43, 63
- display components 9
- display panel
 - product description 1
 - removing 45
- display rear cover
 - spare part number 22
- Display Rubber Kit
 - contents 24
 - spare part number 24
- display specifications 95
- display subcomponents
 - removal 43
 - spare part numbers 43
- DisplayPort, identifying USB Type-C 6
- drive light, identifying 8
- drives
 - preventing damage 28
- E**
- electrostatic discharge 28
- embedded numeric keypad, identifying 13
- equipment guidelines 30
- esc key, identifying 13
- Ethernet, product description 2
- external media cards, product description 3
- F**
- fan/heat sink
 - removal 58
 - spare part number 58
- fingerprint reader assembly
 - removal 50
 - spare part number 19, 50
- fingerprint reader, identifying 12
- fn key, identifying 13
- fn lock light, identifying 11

G

- graphics, product description 1
- grounding guidelines 28
- guidelines
 - equipment 30
 - grounding 28
 - packaging 29
 - transporting 29
 - workstation 29

H

- hard drive
 - precautions 28
- HDMI port, identifying 6
- heat sink
 - spare part number 19
- hinge cover
 - spare part number 22
- Hinge Kit
 - spare part number 22
- hinges
 - removing 45
- hot keys
 - microphone mute 14
- HP PC Hardware Diagnostics UEFI
 - downloading 86
 - starting 86
 - using 85
- HP PC Hardware Diagnostics Windows
 - downloading 84
 - installing 85
 - using 84
- HP Recovery Manager
 - correcting boot problems 93
 - starting 92
- HP Recovery media
 - recovery 92
 - using 90
- HP Recovery partition
 - recovery 92
 - removing 93
- HP Sure Start 102

I

- I/O board
 - removal 53
 - spare part number 19, 53
- internal microphones, identifying 9

J

- jacks
 - audio-out (headphone)/audio-in (microphone) combo 8
 - network 6
 - RJ-45 (network) 6

K

- keyboard
 - product description 3
 - removal 40
 - spare part numbers 19, 40
- keyboard backlight
 - action key 14
- keypad
 - embedded numeric 13
- keys
 - action 14
 - esc 13
 - fn 13
 - Windows 13
 - Windows application 13

L

- labels
 - Bluetooth 17
 - regulatory 17
 - serial number 16
 - service 16
 - wireless certification 17
 - WLAN 17
- latches
 - service door release 15
- left control zone, identifying 10
- left side components 7
- lights
 - AC adapter and battery 6
 - battery 6
 - camera 9
 - caps lock 11
 - fn lock 11
 - hard drive 8
 - microphone mute 11
 - num lock 11
 - RJ-45 (network) 6
 - wireless 11

M

- memory
 - nonvolatile 97
 - volatile 97

- memory card reader, identifying 8
 - memory module
 - product description 1
 - removal 33
 - spare part numbers 20, 33
 - microphone (audio-in) jack
 - product description 2
 - microphone mute key, identifying 14
 - microphone mute light, identifying 11
 - MicroSD memory card reader, identifying 8
 - mini card
 - product description 2
 - minimized image recovery 92
 - minimized image, creating 91
 - model name 1
 - mute volume action key 14
- ## N
- network jack, identifying 6
 - nonvolatile memory 97
 - num lock light 11
- ## O
- operating system, product description 4
 - optical drive
 - precautions 28
 - original system recovery 91
- ## P
- packaging guidelines 29
 - plastic parts 27
 - Plastics Kit
 - contents 25
 - spare part number 25
 - pointing device, product description 3
 - ports
 - HDMI 6
 - product description 3
 - USB SuperSpeed 6, 8
 - USB Type-C SuperSpeed 6
 - power button board
 - removal 77
 - spare part number 20, 77
 - power button, identifying 7
 - power cable
 - spare part number 20

- power connector
 - identifying 7
- power connector cable
 - removal 79
 - spare part number 79
- power cord
 - set requirements 103
 - spare part numbers 26
- power requirements, product description 3
- processor
 - product description 1
- product description
 - audio 2
 - camera 2
 - display panel 1
 - Ethernet 2
 - external media cards 3
 - graphics 1
 - keyboard 3
 - memory module 1
 - microphone 2
 - mini card 2
 - operating system 4
 - pointing devices 3
 - ports 3
 - power requirements 3
 - processors 1
 - product name 1
 - security 4
 - serviceability 5
 - wireless 2
- product name 1
- product name and number, computer 16
- R**
- recovery 89
 - discs 90, 92
 - HP Recovery Manager 91
 - HP Recovery partition 91
 - media 92
 - starting 92
 - supported discs 90
 - system 91
 - USB flash drive 92
 - using HP Recovery media 90
- recovery media
 - creating using HP Cloud Recovery Download Tool 91
 - creating using HP Recovery Manager 90
 - creating using Windows tools 89
 - discs 90
 - HP Recovery partition 89
 - USB flash drive 90
 - using 90
- recovery partition, removing 93
- regulatory information
 - regulatory label 17
 - wireless certification labels 17
- Remote HP PC Hardware Diagnostics
 - UEFI settings
 - customizing 87
 - using 87
- removal/replacement
 - preliminaries 27
 - procedures, Authorized Service Provider 43
 - procedures, Customer Self-Repair 31
- removing personal data from volatile system memory 97
- restoring 89
- right control zone, identifying 10
- right side components 6
- RJ-45 (network) jack, identifying 6
- RJ-45 (network) lights, identifying 6
- RTC battery
 - removal 54
 - spare part number 19, 54
- rubber antenna guide
 - spare part number 22
- Rubber Kit
 - contents 26
 - spare part number 26
- S**
- screen brightness action keys 14
- Screw Kit, spare part number 26
- security cable slot, identifying 7
- security, product description 4
- serial number, computer 16
- service considerations 27
- service door release latch 15
- service doors
 - removing 32
 - spare part number 32
- service labels, locating 16
- serviceability, product description 5
- setup utility
 - navigating and selecting 80
 - restoring factory settings 81
- slots
- security cable 7
- solid-state drive
 - removal 39
 - spare part numbers 20, 39
 - specifications 96
- speaker assembly
 - removal 61
 - spare part number 19, 61
- speaker volume action keys 14
- speakers, identifying 12
- special keys, using 13
- specifications
 - computer 94
 - display 95
 - solid-state drive 96
- supported discs, recovery 90
- Sure Start
 - using 83
- switch screen image action key 14
- system board
 - removal 55
 - spare part numbers 19, 55
- system memory, removing personal data from volatile 97
- system recovery 91
- system restore point, creating 89
- T**
- thermal material, replacement 59, 60
- tools required 27
- top cover
 - removal 47
 - spare part number 19, 47
- touch control board
 - removing 64
- touch controller board
 - spare part number 21
- TouchPad
 - spare part number 19
- TouchPad assembly
 - removal 49
 - spare part number 49
- TouchPad zone
 - identifying 10

- TPM settings 83
- transporting guidelines 29
- traveling with the computer 17

U

- USB SuperSpeed port, identifying 6
- USB SuperSpeed powered port, identifying 8
- USB Type-C SuperSpeed port, identifying 6

V

- vents, identifying 7, 15
- volume
 - adjusting 14
 - mute 14
- volume button, identifying 6

W

- Windows
 - backup 89
 - recovery media 89
 - system restore point 89
- Windows application key, identifying 13
- Windows key, identifying 13
- Windows tools, using 89
- wireless action key 14
- wireless antennas
 - disconnecting 35
- wireless antennas, identifying 9
- wireless certification label 17
- wireless light, identifying 11
- wireless, product description 2
- WLAN antennas, identifying 9
- WLAN device 17
- WLAN label 17
- WLAN/Bluetooth combo card
 - removal 35
 - spare part number 20, 35
- workstation guidelines 29
- WWAN antennas, identifying 9
- WWAN module
 - removal 37
 - spare part numbers 37