



HP 14 Laptop PC

Maintenance and Service Guide

© Copyright 2018 HP Development Company, L.P.

AMD and AMD Radeon are trademarks of Advanced Micro Devices, Inc. Bluetooth is a trademark owned by its proprietor and used by HP Inc. under license. Intel and Core are trademarks of Intel Corporation in the U.S. and other countries. Microsoft and Windows are trademarks of the Microsoft group of companies.

The information contained herein is subject to change without notice. The only warranties for HP products and services are set forth in the express warranty statements accompanying such products and services. Nothing herein should be construed as constituting an additional warranty. HP shall not be liable for technical or editorial errors or omissions contained herein.

Second Edition: September 2018

First Edition: April 2018

Document Part Number: L19035-002

Product notice

This user guide describes features that are common to most models. Some features may not be available on your computer.

Not all features are available in all editions of Windows. This computer may require upgraded and/or separately purchased hardware, drivers and/or software to take full advantage of Windows functionality. Go to <http://www.microsoft.com> for details.

Software terms

By installing, copying, downloading, or otherwise using any software product preinstalled on this computer, you agree to be bound by the terms of the HP End User License Agreement (EULA). If you do not accept these license terms, your sole remedy is to return the entire unused product (hardware and software) within 14 days for a full refund subject to the refund policy of your seller.

For any further information or to request a full refund of the price of the computer, please contact your seller.

Safety warning notice

⚠ WARNING! To reduce the possibility of heat-related injuries or of overheating the device, do not place the device directly on your lap or obstruct the device air vents. Use the device only on a hard, flat surface. Do not allow another hard surface, such as an adjoining optional printer, or a soft surface, such as pillows or rugs or clothing, to block airflow. Also, do not allow the AC adapter to contact the skin or a soft surface, such as pillows or rugs or clothing, during operation. The device and the AC adapter comply with the user-accessible surface temperature limits defined by the International Standard for Safety of Information Technology Equipment (IEC 60950-1).

Table of contents

1 Product description	1
2 Getting to know your computer	6
Right side	6
Left side	7
Display	8
Keyboard area	9
TouchPad	9
Lights	10
Button, vent, and speakers	11
Special keys	12
Action keys	13
Bottom	14
Labels	15
3 Illustrated parts catalog	16
Computer major components	16
Cables	19
Display assembly subcomponents	20
Mass storage devices	22
Miscellaneous parts	23
4 Removal and replacement procedures preliminary requirements	24
Tools required	24
Service considerations	24
Plastic parts	24
Cables and connectors	25
Drive handling	25
Grounding guidelines	26
Electrostatic discharge damage	26
Packaging and transporting guidelines	27
Workstation guidelines	27
Equipment guidelines	28
5 Removal and replacement procedures for Authorized Service Provider parts	29
Component replacement procedures	29

Bottom cover	30
Battery	32
Memory	34
Hard drive	36
Solid-state drive	38
WLAN module	39
System board hook	41
Speakers	42
TouchPad button board	43
Fan	44
Heat sink assembly	45
TouchPad module	49
System board	50
Power connector cable (DC-in)	54
USB/card reader/power button board	55
Display assembly	56
Top cover with keyboard	65

6 Using Setup Utility (BIOS) 66

Starting Setup Utility (BIOS)	66
Updating Setup Utility (BIOS)	66
Determining the BIOS version	66
Downloading a BIOS update	67

7 Using HP PC Hardware Diagnostics 68

Using HP PC Hardware Diagnostics Windows (select products only)	68
Downloading HP PC Hardware Diagnostics Windows	68
Downloading the latest HP PC Hardware Diagnostics Windows version	69
Downloading HP Hardware Diagnostics Windows by product name or number (select products only)	69
Installing HP PC Hardware Diagnostics Windows	69
Using HP PC Hardware Diagnostics UEFI	69
Starting HP PC Hardware Diagnostics UEFI	70
Downloading HP PC Hardware Diagnostics UEFI to a USB flash drive	70
Downloading the latest HP PC Hardware Diagnostics UEFI version	70
Downloading HP PC Hardware Diagnostics UEFI by product name or number (select products only)	70
Using Remote HP PC Hardware Diagnostics UEFI settings (select products only)	71
Downloading Remote HP PC Hardware Diagnostics UEFI	71
Downloading the latest Remote HP PC Hardware Diagnostics UEFI version	71

Downloading Remote HP PC Hardware Diagnostics UEFI by product name or number	71
Customizing Remote HP PC Hardware Diagnostics UEFI settings	71
8 Backing up, restoring, and recovering	73
Backing up information and creating recovery media	73
Using Windows tools	73
Using the HP Cloud Recovery Download Tool to create recovery media (select products only)	73
Restoring and recovery	74
Restoring, resetting, and refreshing using Windows tools	74
Recovering using HP Recovery media	74
Changing the computer boot order	74
9 Specifications	75
Computer specifications	75
35.6-cm (14.0-in) display specifications	76
M.2 SATA solid-state drive specifications	76
M.2 PCIe solid-state drive specifications	77
Hard drive specifications	78
10 Power cord set requirements	79
Requirements for all countries	79
Requirements for specific countries and regions	79
11 Recycling	81
Index	82

1 Product description

Category	Description
Product Name	HP 14 Laptop PC Model numbers: 14-ck0xxx, 14-ck1xxx 14g-cr0xxx, 14g-cr1xxx 14q-cs0xxx, 14q-cs1xxx 14t-ck000, 14t-ck100
Processor	8th-generation Intel® Core™ processors: Intel Core i7-8565U Intel Core i7-8550U Intel Core i5-8265U Intel Core i5-8250U Intel Core i3-8130U 7th-generation Intel Core processors: Intel Core i3-7020U Intel Pentium® and Celeron® processors: Intel Pentium Silver N5000 Intel Celeron N4000
Graphics	Supports HD decode, DX12, HDMI Supports MR ready Internal graphics: Intel UHD Graphics 620: 8th generation Intel processors Intel UHD Graphics 605: Intel Pentium processors Intel UHD Graphics 600: Intel Celeron processors Intel HD Graphics 620: 7th generation Intel processors Intel HD Graphics External graphics: AMD Radeon 520 with up to 4 GB of dedicated video memory AMD Radeon 520 with up to 2 GB of dedicated video memory
Panel	35.6-cm (14.0-in), WLED, slim, 220 nits, eDP, non-touch: High definition (HD)(1366×768), anti glare, SVA

Category	Description
	HD (1366×768), BrightView, SVA
	Full high-definition (FHD)(1920×1080), anti glare, SVA
	Full high-definition (FHD)(1920×1080), anti glare, UWVA, narrow bezel
	FHD (1920×1080), BrightView, UWVA, narrow bezel
Memory	Two memory module slots (7th and 8th generation Intel Core processors)
	Memory is non-customer accessible/non-upgradeable
	DDR4-2400 dual channel support (8th generation Intel processors)
	DDR4-2133 dual channel support (7th generation Intel processors)
	Supports up to 16 GB of system RAM in the following configurations:
	<ul style="list-style-type: none"> • 16384 MB (8192 MB×2) • 12288 MB (8192 MB×1 + 4096 MB×1) • 8192 MB (8192 MB×1) • 4096 MB (4096 MB×1)
	One memory module slot (Intel Pentium and Celeron processors)
	Memory is non-customer accessible/non-upgradeable
	DDR4-2400 Dual Channel Support
	Supports up to 8 GB of system RAM in the following configurations:
	<ul style="list-style-type: none"> • 8192 MB (8192 MB×1) • 4096 MB (4096 MB×1)
Primary storage	Single hard drive configurations, 6.35 cm (2.5-in), 7.0/7.2 mm, SATA hard drives:
	1 TB, 5400 rpm, 7.0 mm
	500 GB, 5400 rpm, 7.0 mm
	M.2, SATA-3, solid-state drives:
	256 GB, TLC
	128 GB, TLC
	PCIe, NVMe, M.2 solid-state drives (7th and 8th generation Intel Core processors):
	512 GB
	256 GB
	Dual storage configurations (7th and 8th generation Intel Core processors):
	256 GB PCIe solid-state drive + 1 TB, 5400 rpm hard drive
	128 GB SATA, TLC solid-state drive + 1 TB, 5400 rpm hard drive
	eMMC configurations: (Intel Pentium and Celeron processors)
	64 GB
Camera	HP TrueVision HD Camera - indicator LED, USB2.0, HD BSI sensor, f2.0, WDR

Category	Description
	720p by 30 frames per second
	Single digital microphone
	HP Webcam - VGA camera, indicator LED, USB 2.0, f2.4
	640×480 by 30 frames per second
	Single digital microphone
Audio	Audio application name: HP Audio Control
	Dual speakers
Ethernet	Ethernet Integrated 10/100/1000 NIC
Wireless networking	Compatible with Miracast-certified devices
	Integrated Wireless options with dual antennas (M.2/PCIe):
	Intel Dual band wireless-AC 3168 802.11AC 1×1 WiFi + Bluetooth 4.2 Combo Adaptor (non-vPro) (7th and 8th generation Intel Core processors)
	Realtek RTL8822BE 802.11 ac 2×2 WiFi + Bluetooth 4.2 Combo Adapter (MU-MIMO supported)
	Integrated Wireless options with single antenna (M.2/PCIe):
	Intel Dual Band Wireless-AC 9461 802.11 AC 1×1 WiFi + BT5 Combo Adapter (non-vPro) (MU-MIMO supported)
	Realtek RTL8821CE 802.11 ac 1×1 WiFi + Bluetooth 4.2 Combo Adapter (MU-MIMO supported)
	Realtek RTL8723DE 802.11 bgn 1×1 WiFi + Bluetooth 4.2 Combo Adapter
External media cards	HP Multi-Format Digital Media Card Reader
	Supports SD/SDHC/SDXC
	Push-pull insertion/removal
Internal card expansion	One M.2 slot for solid-state drive (7th and 8th generation Intel Core processors)
	One M.2 slot for WLAN
Ports	USB 2.0 port (left side)
	(2) USB 3.1 Gen 1 ports (right side)
	HDMI v1.4b supporting: up to 1920×1080 @ 60Hz
	RJ-45/Ethernet
	Audio-out (headphone)/audio-in (microphone) combo jack
	AC Smart Pin adapter plug
Keyboard/pointing devices	Keyboard:
	Full-size, textured, island-style keyboard
	Full-size, textured, 2-coat paint, backlit, island-style keyboard
	TouchPad:
	Image sensor
Power requirements	Battery:
	3-cell Prismatic/Polymer battery, 41 Whr

Category	Description
	Supports battery fast charge
	AC adapter, barrel type:
	65 W Smart, nPFC, right angle, 4.5 mm (models with discrete graphics)
	65 W Smart, nPFC, 4.5 mm (Argentina) (models with discrete graphics)
	65 W Smart, nPFC, 4.5 mm, EM
	45 W Smart, nPFC, right angle, 4.5 mm (models with UMA graphics)
	45 W Smart, nPFC, 4.5 mm (Argentina) (models with UMA graphics)
	Power cord (C5):
	1 m, conventional
Security	Kensington Mini Security Slot
	Supports Trusted Platform Module (TPM) 2.0 (Infineon, soldered down)
Operating system	FreeDOS 2.0
	Windows 10 Home 64
	Windows 10 Home 64 Chinese Market CPPP
	Windows 10 Home 64 High-End Chinese Market CPPP
	Windows 10 Home 64 Plus
	Windows 10 Home 64 Plus Single Language
	Windows 10 Home 64 Plus Single Language APAC EM PPP
	Windows 10 Home 64 Plus Single Language India Market PPP
	Windows 10 Home 64 Plus Single Language Indonesia Market PPP
	Windows 10 Home 64 Single Language
	Windows 10 Home 64 Single Language APAC EM PPP
	Windows 10 Home 64 Single Language India Market PPP
	Windows 10 Home 64 Single Language Indonesia Market PPP
	Windows 10 Home 64 Single Language Value APAC EM PPP
	Windows 10 Home 64 Single Language Value India Market PPP
	Windows 10 Home 64 Single Language Value Indonesia Market PPP
	Windows 10 Home 64 Value Notebook Compact (Intel Pentium and Celeron processors only)
	Windows 10 Home 64 Value Notebook Single Language (Intel Pentium and Celeron processors only)
	Windows 10 Home 64 Value Notebook Single Language Compact (Intel Pentium and Celeron processors only)
	Windows 10 Home 64 Value Notebook Single Language SEAP (Intel Pentium and Celeron processors only)
	Windows 10 Home 64 Value Notebook Single Language select GEO (Intel Pentium and Celeron processors only)
	Windows 10 Home 64 Value Notebook Single Language select GEO Compact
	Windows 10 Home 64 Value Notebook Web/Kiosk (Intel Pentium and Celeron processors only)





Category	Description
	Windows 10 Home 64 Web/Kiosk
	Windows 10 Pro 64
Serviceability	End user replaceable parts:
	AC adapter

2 Getting to know your computer

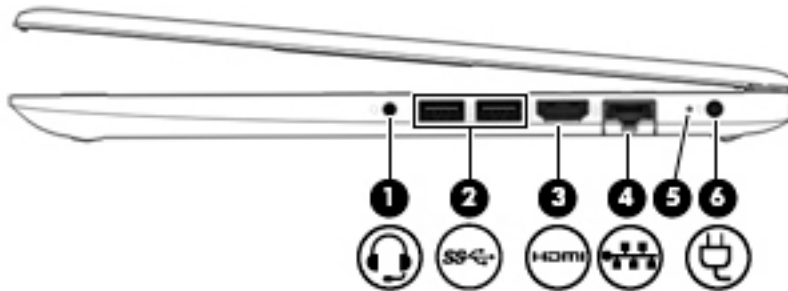
Your computer features top-rated components. This chapter provides details about your components, where they are located, and how they work.





Right side

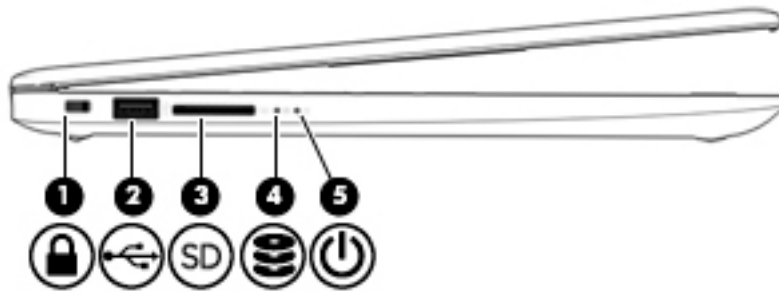

Component	Description
(1)  Audio-out (headphone)/Audio-in (microphone) combo jack	<p>Connects optional powered stereo speakers, headphones, earbuds, a headset, or a television audio cable. Also connects an optional headset microphone. This jack does not support optional standalone microphones.</p> <p>WARNING! To reduce the risk of personal injury, adjust the volume before putting on headphones, earbuds, or a headset. For additional safety information, see the <i>Regulatory, Safety, and Environmental Notices</i>.</p> <p>To access this guide:</p> <ul style="list-style-type: none">▲ Select the Start button, select HP Help and Support, and then select HP Documentation. <p>NOTE: When a device is connected to the jack, the computer speakers are disabled.</p>
(2)  USB SuperSpeed ports (2)	<p>Connect a USB device, such as a cell phone, camera, activity tracker, or smartwatch, and provide high-speed data transfer.</p>
(3)  HDMI port	<p>Connects an optional video or audio device, such as a high-definition television, any compatible digital or audio component, or a high-speed High-Definition Multimedia Interface (HDMI) device.</p>
(4)  RJ-45 (network) jack/status lights	<p>Connects a network cable.</p> <ul style="list-style-type: none">• White: The network is connected.• Amber: Activity is occurring on the network.
(5) AC adapter and battery light	<ul style="list-style-type: none">• White: The AC adapter is connected and the battery is fully charged.• Blinking white: The AC adapter is disconnected and the battery has reached a low battery level.• Amber: The AC adapter is connected and the battery is charging.• Off: The battery is not charging.
(6)  Power connector	<p>Connects an AC adapter.</p>

Left side



Component	Description
(1) 	<p>Security cable slot</p> <p>Attaches an optional security cable to the computer.</p> <p>NOTE: The security cable is designed to act as a deterrent, but it may not prevent the computer from being mishandled or stolen.</p>
(2) 	<p>USB port</p> <p>Connects a USB device, such as a cell phone, camera, activity tracker, or smartwatch, and provides data transfer.</p>
(3) 	<p>Memory card reader</p> <p>Reads optional memory cards that enable you to store, manage, share, or access information.</p> <p>To insert a card:</p> <ol style="list-style-type: none">1. Hold the card label-side up, with connectors facing the computer.2. Insert the card into the memory card reader, and then press in on the card until it is firmly seated. <p>To remove a card:</p> <ul style="list-style-type: none">▲ Press in on the card, and then remove it from the memory card reader.
(4) 	<p>Drive light</p> <ul style="list-style-type: none">• Blinking white: The storage device is being accessed.
(5) 	<p>Power light</p> <ul style="list-style-type: none">• On: The computer is on.• Blinking: The computer is in the Sleep state, a power-saving state. The computer shuts off power to the display and other unneeded components.• Off: The computer is off or in Hibernation. Hibernation is a power-saving state that uses the least amount of power.

Display

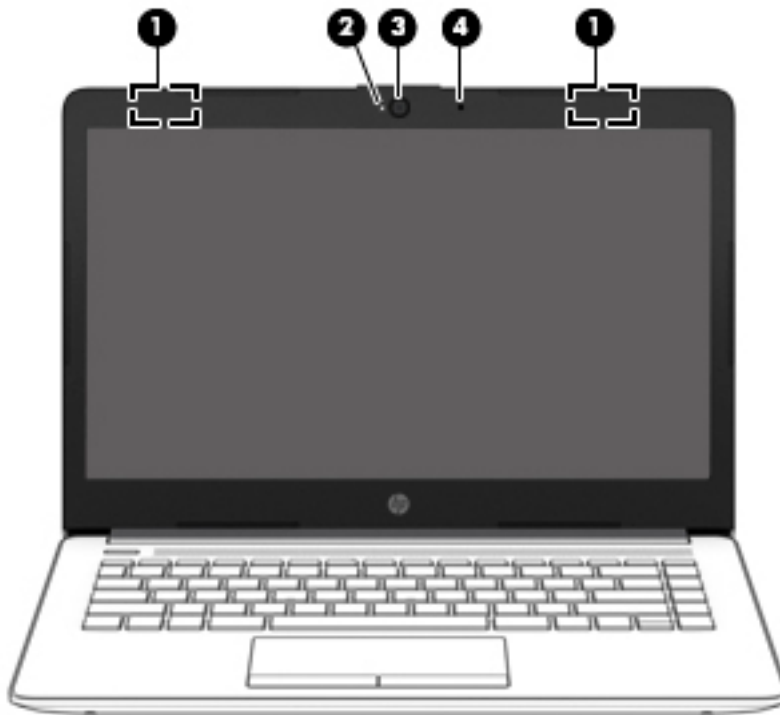

Component	Description
(1) WLAN antennas* (1 or 2 depending on model)	Send and receive wireless signals to communicate with wireless local area networks (WLANs).
(2) Camera light	On: The camera is in use.
(3) Camera	Allows you to video chat, record video, and record still images. Some cameras also allow a facial recognition logon to Windows, instead of a password logon. NOTE: Camera functions vary depending on the camera hardware and software installed on your product.
(4) Internal microphone	Records sound.

*The antennas are not visible from the outside of the computer. For optimal transmission, keep the areas immediately around the antennas free from obstructions.

For wireless regulatory notices, see the section of the *Regulatory, Safety, and Environmental Notices* that applies to your country or region.

To access this guide:

- ▲ Select the **Start** button, select **HP Help and Support**, and then select **HP Documentation**.

Keyboard area

TouchPad

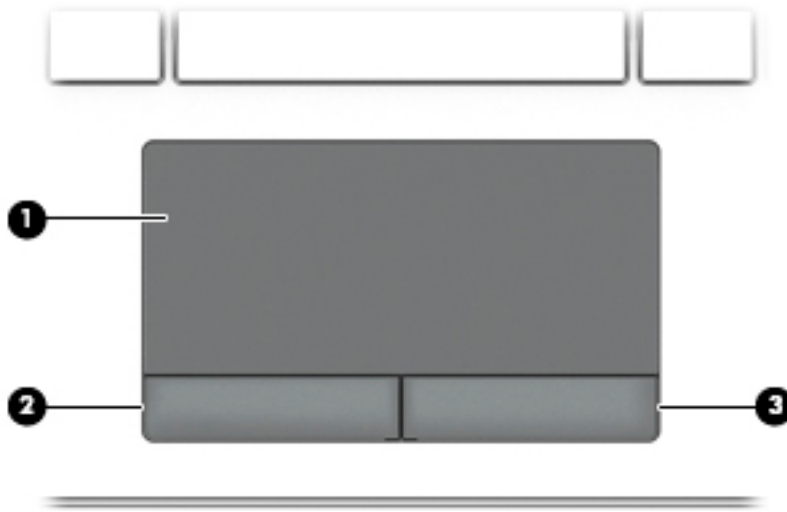

Component		Description
(1)	TouchPad zone	Reads your finger gestures to move the pointer or activate items on the screen.
(2)	Left TouchPad button	Functions like the left button on an external mouse.
(3)	Right TouchPad button	Functions like the right button on an external mouse.

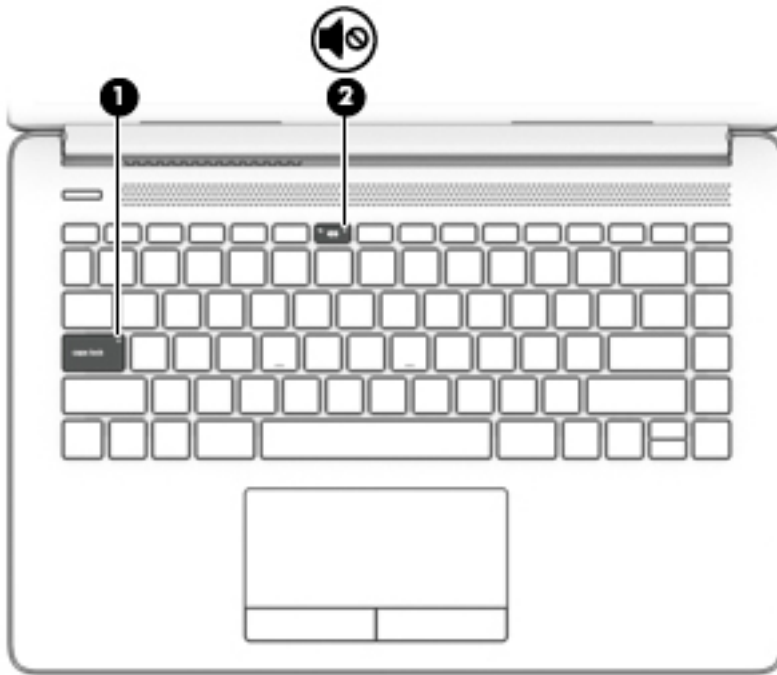

Lights

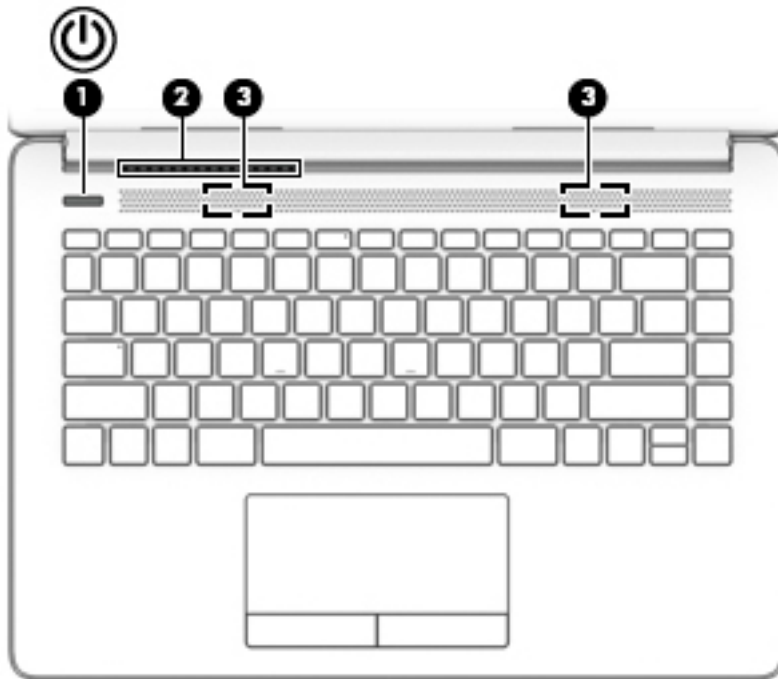

Component		Description
(1)	Caps lock light	On: Caps lock is on, which switches the key input to all capital letters.
(2)	 Mute light	<ul style="list-style-type: none">• On: Computer sound is off.• Off: Computer sound is on.

Button, vent, and speakers



Component	Description
(1)  Power button	<ul style="list-style-type: none"> • When the computer is off, press the button to turn on the computer. • When the computer is on, press the button briefly to initiate Sleep. • When the computer is in the Sleep state, press the button briefly to exit Sleep. • When the computer is in Hibernation, press the button briefly to exit Hibernation. <p>CAUTION: Pressing and holding down the power button results in the loss of unsaved information.</p> <p>If the computer has stopped responding and shutdown procedures are ineffective, press and hold the power button down for at least 5 seconds to turn off the computer.</p> <p>To learn more about your power settings, see your power options:</p> <ul style="list-style-type: none"> ▲ Right-click the Power icon , and then select Power Options.
(2) Vent	<p>Enables airflow to cool internal components.</p> <p>NOTE: The computer fan starts up automatically to cool internal components and prevent overheating. It is normal for the internal fan to cycle on and off during routine operation.</p>
(3) Speakers (2)	Produce sound.

Special keys

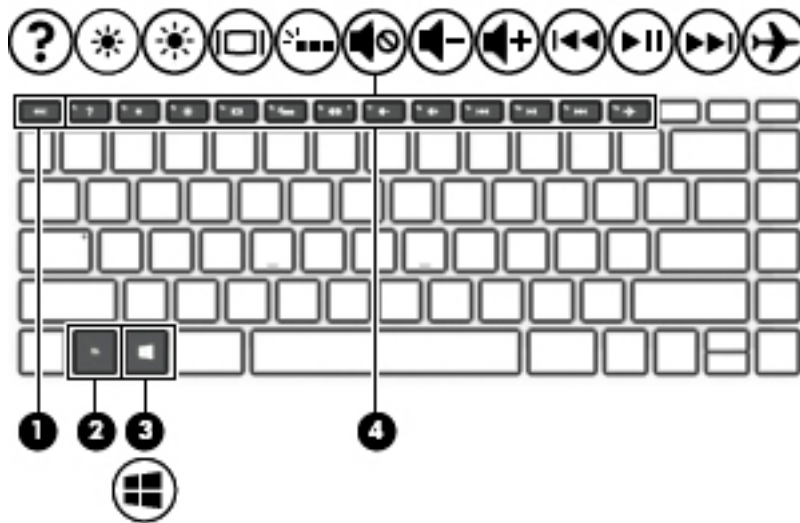













Component	Description
(1) esc key	Displays system information when pressed in combination with the fn key.
(2) fn key	Executes specific functions when pressed in combination with another key.
(3)  Windows key	Opens the Start menu. NOTE: Pressing the Windows key again will close the Start menu.
(4) Action keys	Execute frequently used system functions. NOTE: On select products, the f5 action key turns the keyboard backlight feature off or on.

Action keys

An action key performs the function indicated by the icon on the key. To determine which keys are on your product, see [Special keys on page 12](#).

- ▲ To use an action key, press and hold the key.

Icon	Description
	Opens the “How to get help in Windows 10” webpage.
	Decreases the screen brightness incrementally as long as you hold down the key.
	Increases the screen brightness incrementally as long as you hold down the key.
	Switches the screen image between display devices connected to the system. For example, if a monitor is connected to the computer, repeatedly pressing this key alternates the screen image from the computer display to the monitor display to a simultaneous display on both the computer and the monitor.
	Turns the keyboard backlight off or on. To conserve battery power, turn off this feature.
	Mutes or restores speaker sound.
	Decreases speaker volume incrementally while you hold down the key.
	Increases speaker volume incrementally while you hold down the key.
	Plays the previous track of an audio CD or the previous section of a DVD or a Blu-ray Disc (BD).
	Starts, pauses, or resumes playback of an audio CD, a DVD, or a BD.
	Plays the next track of an audio CD or the next section of a DVD or a BD.
	Turns the airplane mode and wireless feature on or off. NOTE: The airplane mode key is also referred to as the wireless button. NOTE: A wireless network must be set up before a wireless connection is possible.

Bottom

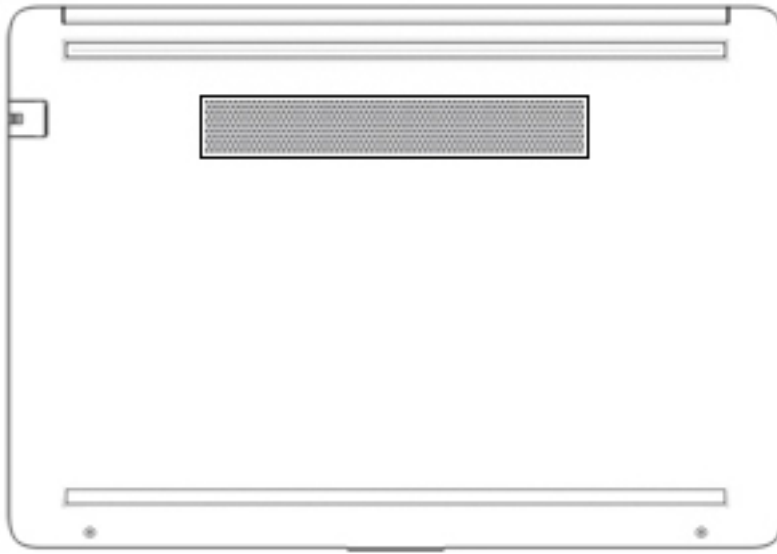

Component	Description
-----------	-------------

Vent

Enables airflow to cool internal components.

NOTE: The computer fan starts up automatically to cool internal components and prevent overheating. It is normal for the internal fan to cycle on and off during routine operation.

Labels

The labels affixed to the computer provide information you may need when you troubleshoot system problems or travel internationally with the computer. Labels may be in paper form or imprinted on the product.

 **IMPORTANT:** Check the following locations for the labels described in this section: the bottom of the computer, inside the battery bay, under the service door, on the back of the display, or on the bottom of a tablet kickstand.

- Service label—Provides important information to identify your computer. When contacting support, you may be asked for the serial number, the product number, or the model number. Locate this information before you contact support.

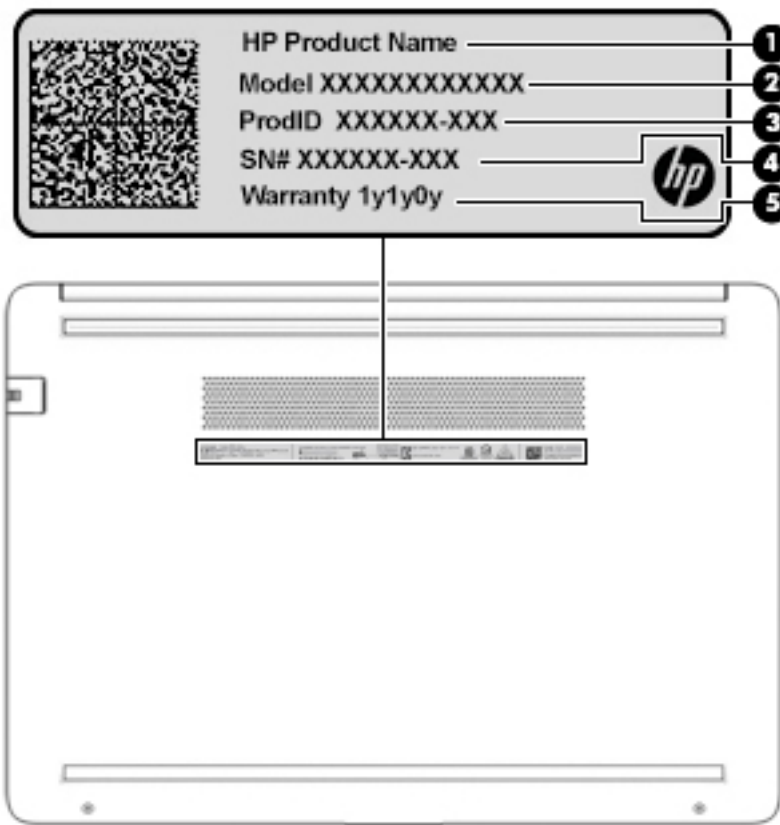

Component

- | Component |
|---------------------|
| (1) HP product name |
| (2) Model number |
| (3) Product ID |
| (4) Serial number |
| (5) Warranty period |

- Regulatory label(s)—Provide(s) regulatory information about the computer.
- Wireless certification label(s)—Provide(s) information about optional wireless devices and the approval markings for the countries or regions in which the devices have been approved for use.

3 Illustrated parts catalog

Computer major components

 **NOTE:** HP continually improves and changes product parts. For complete and current information on supported parts for your computer, go to <http://partsurfer.hp.com>, select your country or region, and then follow the on-screen instructions.

 **NOTE:** Details about your computer, including model, serial number, product key, and length of warranty, are on the service tag at the bottom of your computer. See [Labels on page 15](#) for details.

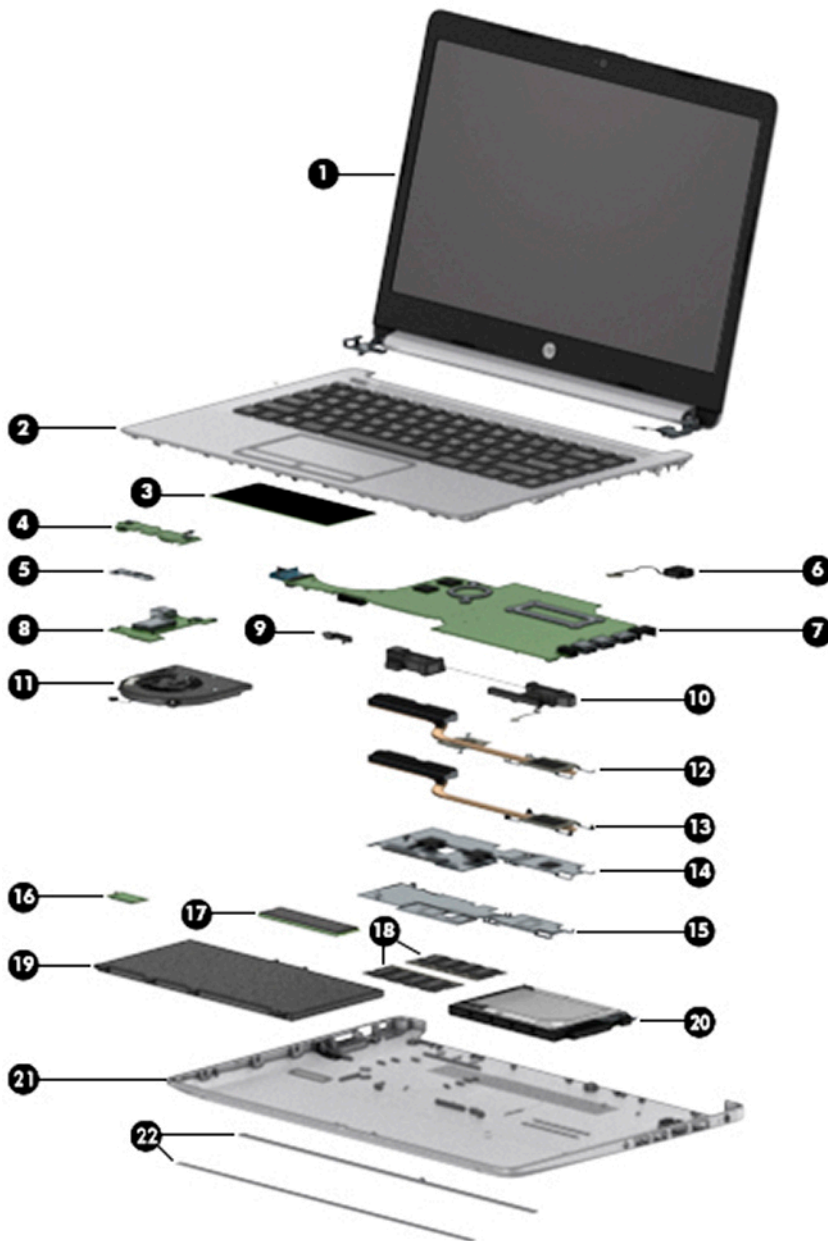

Item	Component	Spare part number
(1)	Display NOTE: Displays are not spared as whole units. Display subcomponent spare parts are available. For spare part information, see Display assembly subcomponents on page 20 .	Not spared
(2)	Top cover/keyboard NOTE: For a detailed list of country codes, see Top cover with keyboard on page 65 .	
	Keyboard, no backlight, jet black	L23239-xx1
	Keyboard, no backlight, snow white	L23240-xx1
	Keyboard, no backlight, ash silver	L23241-xx1
	Keyboard, backlit, ash silver	L23242-xx1
(3)	TouchPad module	L22586-001
(4)	TouchPad button board	L23197-001
(5)	TouchPad button board bracket	L23193-001
(6)	Power connector cable (DC-in)	L23188-001
(7)	System board NOTE: All system board spare part kits include replacement thermal material. All system boards use the following part numbers: xxxxxx-001: Non-Windows operating systems xxxxxx-601: Windows operating system For use in models with discrete graphics memory:	
	<ul style="list-style-type: none"> Intel Core i7-8565U processor with 2 GB of discrete graphics memory 	L38148-xx1
	<ul style="list-style-type: none"> Intel Core i7-8550U processor with 2 GB of discrete graphics memory 	L23228-xx1
	<ul style="list-style-type: none"> Intel Core i5-8265U processor with 4 GB of discrete graphics memory 	L38149-xx1
	<ul style="list-style-type: none"> Intel Core i5-8265U processor with 2 GB of discrete graphics memory 	L38150-xx1
	<ul style="list-style-type: none"> Intel Core i5-8250U processor with 4 GB of discrete graphics memory 	L23229-xx1
	<ul style="list-style-type: none"> Intel Core i5-8250U processor with 2 GB of discrete graphics memory 	L23227-xx1
	<ul style="list-style-type: none"> Intel Core i3-7020U processor with 2 GB of discrete graphics memory 	L23226-xx1
	For use in models with UMA graphics memory:	
	<ul style="list-style-type: none"> Intel Core i7-8550U processor 	L23233-xx1
	<ul style="list-style-type: none"> Intel Core i5-8265U processor 	L38151-xx1
	<ul style="list-style-type: none"> Intel Core i5-8250U processor 	L23232-xx1
	<ul style="list-style-type: none"> Intel Core i3-8130U processor 	L23231-xx1
	<ul style="list-style-type: none"> Intel Core i7-7500U processor 	L42280-xx1
	<ul style="list-style-type: none"> Intel Core i5-7200U processor 	L42279-xx1
	<ul style="list-style-type: none"> Intel Core i3-7100U processor 	L42278-xx1

Item	Component	Spare part number
	<ul style="list-style-type: none"> Intel Core i3-7020U processor 	L23230-xx1
	<ul style="list-style-type: none"> Intel Pentium N5000 processor 	L23236-xx1
	<ul style="list-style-type: none"> Intel Celeron N4000 processor 	L23234-xx1
	<ul style="list-style-type: none"> Intel Celeron N4000 processor, models with 64 GB eMMC memory 	L23235-xx1
(8)	USB/card reader/power button board	L23196-001
(9)	System board hook	L23206-001
(10)	Speakers (includes cable)	L23221-001
(11)	Fan	L23189-001
	Heat sink	
(12)	For use in models with Intel Core processors and discrete graphics	L23192-001
(13)	For use in models with Intel Core processors and integrated UMA graphics	L23191-001
(14)	For use in fanless models with Intel Pentium and Celeron processors	L23190-001
(15)	Fan insert (for use in fanless models)	L23198-001
(16)	WLAN module	
	Intel Dual Band Wireless-AC 9461 802.11 AC 1×1 WiFi + BT5 Combo Adapter (non-vPro) (MU-MIMO supported)	L25889-005
	Intel Dual band wireless-AC 3168 802.11AC 1x1 WiFi + Bluetooth 4.2 Combo Adaptor (non-vPro)	863934-855
	Realtek RTL8822BE 802.11 ac 2x2 WiFi + Bluetooth 4.2 Combo Adapter (MU-MIMO supported)	924813-855
	Realtek RTL8821CE 802.11 ac 1x1 WiFi + Bluetooth 4.2 Combo Adapter (MU-MIMO supported)	L17365-005
	Realtek RTL8723DE 802.11 bgn 1x1 WiFi + Bluetooth 4.2 Combo Adapter	L21480-005
(17)	Solid-state drive	
	NOTE: For spare part information, see Mass storage devices on page 22 .	
(18)	Memory modules (2400 MHz DDR4)	
	8 GB	862398-855
	4 GB	862397-859
(19)	Battery (3-cell, 41 WHr, 3.6 Ahr)	L11119-855
(20)	Hard drive	
	NOTE: For spare part information, see Mass storage devices on page 22 .	
(21)	Bottom cover	
	Jet black	L23174-001
	Natural silver	L23175-001
	Pale gold	L23176-001
	Scarlet red	L23177-001
	Twilight blue	L23178-001

Item	Component	Spare part number
	Smoke gray	L23179-001
	Snow white	L23180-001
(22)	Rubber feet	
	Jet black	L23212-001
	Natural silver	L23213-001
	Pale gold	L23214-001
	Scarlet red	L23215-001
	Twilight blue	L23216-001
	Smoke gray	L23217-001
	Snow white	L23218-001

Cables



Item	Component	Spare part number
(1)	USB/card reader/power button board cable	L23186-001
(2)	Display cable	
	HD display panel	L23182-001
	FHD display panel	L23183-001
(3)	TouchPad cable	L23184-001
(4)	TouchPad button board cable	L23185-001
(5)	Hard drive cable	L23187-001

Display assembly subcomponents

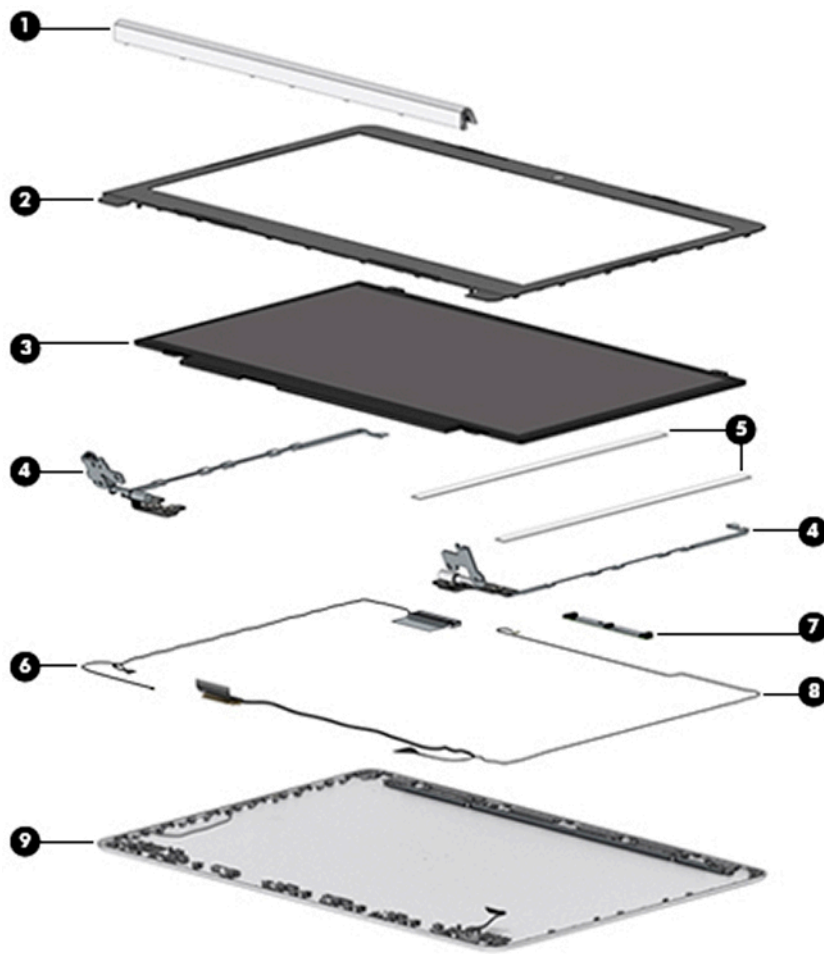

Item	Component	Spare part number
(1)	Hinge cover	
	Jet black	L23199-001
	Natural silver	L23200-001
	Pale gold	L23201-001
	Scarlet red	L23202-001
	Twilight blue	L23203-001
	Smoke gray	L23204-001
	Snow white	L23205-001
(2)	Display bezel	L23181-001
(3)	Display panel	
	FHD, anti glare	L23208-001
	FHD, anti glare, AGOOC	L42787-001
	FHD, BrightView	L23209-001

Item	Component	Spare part number
	HD, anti glare	L23210-001
	HD, BrightView	L23211-001
(4)	Hinge Kit (includes left and right hinges)	
	For use in models with an HD panel	L23194-001
	For use in models with an FHD panel	L23195-001
(5)	Display panel stretchable adhesive tape (not illustrated)	L23207-001
(6)	WLAN antenna cable (included in Antenna Kit)	
	Single antenna, for use in models with an HD panel	L23158-001
	Dual antennas, for use in models with an HD panel	L23159-001
	Single antenna, for use in models with an FHD panel	L24037-001
	Dual antennas, for use in models with an FHD panel	L24038-001
(7)	Camera module	
	HD camera	L23237-001
	VGA camera	L23238-001
(8)	Display cable	
	For use with HD display panels	L23182-001
	For use with FHD display panels	L23183-001
(9)	Back cover	
	For use in models with an HD panel:	
	• Jet black	L23160-001
	• Natural silver	L23161-001
	• Pale gold	L23162-001
	• Scarlet red	L23163-001
	• Twilight blue	L23164-001
	• Smoke gray	L23165-001
	• Snow white	L23166-001
	For use in models with an FHD panel:	
	• Jet black	L23167-001
	• Natural silver	L23168-001
	• Pale gold	L23169-001
	• Scarlet red	L23170-001
	• Twilight blue	L23171-001
	• Smoke gray	L23172-001
	• Snow white	L23173-001

Mass storage devices

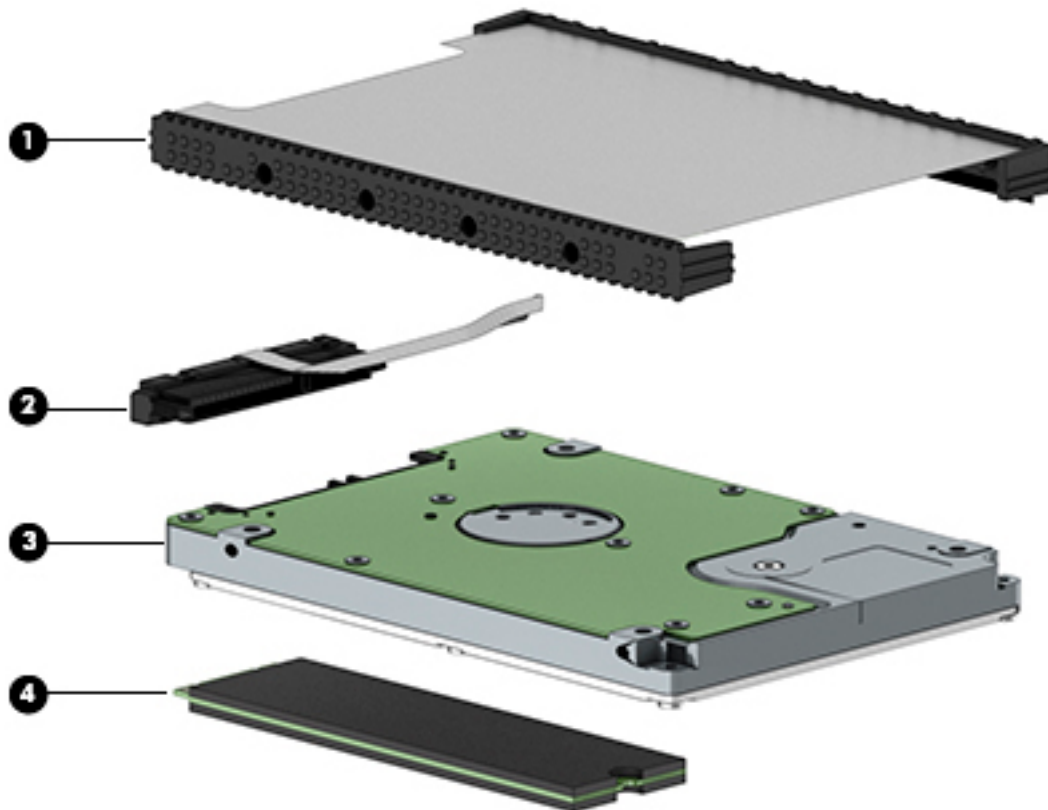

Item	Component	Spare part number
(1)	Hard drive cover	L23219-001
(2)	Hard drive cable	L23187-001
(3)	Hard drive, 7 mm	
	1 TB, 5400 rpm	762990-005
	500 GB, 5400 rpm	778186-005
(4)	Solid-state drive (M.2)	
	512 GB, PCIe, NVMe	L23225-001
	256 GB, PCIe, NVMe	L23224-001
	256 GB, SATA-3, TLC	L23223-001
	128 GB, SATA-3, TLC	L23222-001
	Optane memory module, 16 GB	L42281-001

Miscellaneous parts

Component	Spare part number
AC adapter	
65 W AC adapter, nPFC, S-3P, 4.5 mm	710412-001
65 W AC adapter, nPFC, SMART, RC, 4.5 mm, EM	913691-850
65 W AC adapter, nPFC, 4.5 mm, for use in Argentina	710340-850
45 W AC adapter, nPFC, SMART, RC, 4.5 mm, non-slim	741727-001
45 W AC adapter, nPFC, for use in Argentina	741553-852
Power cord, C5, conventional, 1.0 m	
For use in Argentina	L19357-001
For use in Australia	L19358-001
For use in Brazil	L19359-001
For use in Denmark	L19360-001
For use in Europe	L19361-001
For use in India	L19363-001
For use in Israel	L19362-001
For use in Italy	L19364-001
For use in North America	L19367-001
For use in the People's Republic of China	L19368-001
For use in South Africa	L19369-001
For use in South Korea	L19366-001
For use in Switzerland	L19370-001
For use in Thailand	L19371-001
For use in Taiwan	L19372-001
For use in the United Kingdom	L19373-001
HP HDMI-to-VGA Adapter	701943-001
Screw Kit	L23220-001

4 Removal and replacement procedures preliminary requirements

Tools required

You will need the following tools to complete the removal and replacement procedures:

- Phillips P1 magnetic screwdriver
- Plastic, non-marking pry tool

Service considerations

The following sections include some of the considerations that you must keep in mind during disassembly and assembly procedures.



NOTE: As you remove each subassembly from the computer, place the subassembly (and all accompanying screws) away from the work area to prevent damage.

Plastic parts



CAUTION: Using excessive force during disassembly and reassembly can damage plastic parts. Use care when handling the plastic

Cables and connectors

⚠ CAUTION: When servicing the computer, be sure that cables are placed in their proper locations during the reassembly process. Improper cable placement can damage the computer.

Cables must be handled with extreme care to avoid damage. Apply only the tension required to unseat or seat the cables during removal and insertion. Handle cables by the connector whenever possible. In all cases, avoid bending, twisting, or tearing cables. Be sure that cables are routed in such a way that they cannot be caught or snagged by parts being removed or replaced. Handle flex cables with extreme care; these cables tear easily.

Drive handling

⚠ CAUTION: Drives are fragile components that must be handled with care. To prevent damage to the computer, damage to a drive, or loss of information, observe these precautions:

Before removing or inserting a hard drive, shut down the computer. If you are unsure whether the computer is off or in Hibernation, turn the computer on, and then shut it down through the operating system.

Before handling a drive, be sure that you are discharged of static electricity. While handling a drive, avoid touching the connector.

Before removing an optical drive, be sure that a disc is not in the drive and be sure that the optical drive tray is closed.

Handle drives on surfaces covered with at least one inch of shock-proof foam.

Avoid dropping drives from any height onto any surface.

After removing a hard drive or an optical drive, place it in a static-proof bag.

Avoid exposing an internal hard drive to products that have magnetic fields, such as monitors or speakers.

Avoid exposing a drive to temperature extremes or liquids.

If a drive must be mailed, place the drive in a bubble pack mailer or other suitable form of protective packaging and label the package "FRAGILE."

Grounding guidelines

Electrostatic discharge damage

Electronic components are sensitive to electrostatic discharge (ESD). Circuitry design and structure determine the degree of sensitivity. Networks built into many integrated circuits provide some protection, but in many cases, ESD contains enough power to alter device parameters or melt silicon junctions.

A discharge of static electricity from a finger or other conductor can destroy static-sensitive devices or microcircuitry. Even if the spark is neither felt nor heard, damage may have occurred.

An electronic device exposed to ESD may not be affected at all and can work perfectly throughout a normal cycle. Or the device may function normally for a while, then degrade in the internal layers, reducing its life expectancy.

⚠ CAUTION: To prevent damage to the computer when you are removing or installing internal components, observe these precautions:

Keep components in their electrostatic-safe containers until you are ready to install them.

Before touching an electronic component, discharge static electricity by using the guidelines described in this section.

Avoid touching pins, leads, and circuitry. Handle electronic components as little as possible.

If you remove a component, place it in an electrostatic-safe container.

The following table shows how humidity affects the electrostatic voltage levels generated by different activities.

⚠ CAUTION: A product can be degraded by as little as 700 V.

Typical electrostatic voltage levels			
Event	Relative humidity		
	10%	40%	55%
Walking across carpet	35,000 V	15,000 V	7,500 V
Walking across vinyl floor	12,000 V	5,000 V	3,000 V
Motions of bench worker	6,000 V	800 V	400 V
Removing DIPS from plastic tube	2,000 V	700 V	400 V
Removing DIPS from vinyl tray	11,500 V	4,000 V	2,000 V
Removing DIPS from plastic foam	14,500 V	5,000 V	3,500 V
Removing bubble pack from PCB	26,500 V	20,000 V	7,000 V
Packing PCBs in foam-lined box	21,000 V	11,000 V	5,000 V

Packaging and transporting guidelines

Follow these grounding guidelines when packaging and transporting equipment:

- To avoid hand contact, transport products in static-safe tubes, bags, or boxes.
- Protect ESD-sensitive parts and assemblies with conductive or approved containers or packaging.
- Keep ESD-sensitive parts in their containers until the parts arrive at static-free workstations.
- Place items on a grounded surface before removing items from their containers.
- Always be properly grounded when touching a component or assembly.
- Store reusable ESD-sensitive parts from assemblies in protective packaging or nonconductive foam.
- Use transporters and conveyors made of antistatic belts and roller bushings. Be sure that mechanized equipment used for moving materials is wired to ground and that proper materials are selected to avoid static charging. When grounding is not possible, use an ionizer to dissipate electric charges.

Workstation guidelines

Follow these grounding workstation guidelines:

- Cover the workstation with approved static-shielding material.
- Use a wrist strap connected to a properly grounded work surface and use properly grounded tools and equipment.
- Use conductive field service tools, such as cutters, screwdrivers, and vacuums.
- When fixtures must directly contact dissipative surfaces, use fixtures made only of static safe materials.
- Keep the work area free of nonconductive materials, such as ordinary plastic assembly aids and plastic foam.
- Handle ESD-sensitive components, parts, and assemblies by the case or PCM laminate. Handle these items only at static-free workstations.
- Avoid contact with pins, leads, or circuitry.
- Turn off power and input signals before inserting or removing connectors or test equipment.

Equipment guidelines

Grounding equipment must include either a wrist strap or a foot strap at a grounded workstation.

- When seated, wear a wrist strap connected to a grounded system. Wrist straps are flexible straps with a minimum of one megohm $\pm 10\%$ resistance in the ground cords. To provide proper ground, wear a strap snugly against the skin at all times. On grounded mats with banana-plug connectors, use alligator clips to connect a wrist strap.
- When standing, use foot straps and a grounded floor mat. Foot straps (heel, toe, or boot straps) can be used at standing workstations and are compatible with most types of shoes or boots. On conductive floors or dissipative floor mats, use foot straps on both feet with a minimum of one megohm resistance between the operator and ground. To be effective, the conductive equipment must be worn in contact with the skin.

The following grounding equipment is recommended to prevent electrostatic damage:

- Antistatic tape
- Antistatic smocks, aprons, and sleeve protectors
- Conductive bins and other assembly or soldering aids
- Nonconductive foam
- Conductive tabletop workstations with ground cords of one megohm resistance
- Static-dissipative tables or floor mats with hard ties to the ground
- Field service kits
- Static awareness labels
- Material-handling packages
- Nonconductive plastic bags, tubes, or boxes
- Metal tote boxes
- Electrostatic voltage levels and protective materials

The following table lists the shielding protection provided by antistatic bags and floor mats.

Material	Use	Voltage protection level
Antistatic plastics	Bags	1,500 V
Carbon-loaded plastic	Floor mats	7,500 V
Metallized laminate	Floor mats	5,000 V

5 Removal and replacement procedures for Authorized Service Provider parts

This chapter provides removal and replacement procedures for Authorized Service Provider only parts.

 **CAUTION:** Components described in this chapter should only be accessed by an authorized service provider. Accessing these parts can damage the computer or void the warranty.

CAUTION: This computer does not have user-replaceable parts. Only HP authorized service providers should perform the removal and replacement procedures described here. Accessing the internal part could damage the computer or void the warranty.

Component replacement procedures

 **NOTE:** Details about your computer, including model, serial number, product key, and length of warranty, are on the service tag at the bottom of your computer. See [Labels on page 15](#) for details.

 **NOTE:** HP continually improves and changes product parts. For complete and current information on supported parts for your computer, go to <http://partsurfer.hp.com>, select your country or region, and then follow the on-screen instructions.

There are as many as 42 screws that must be removed, replaced, and/or loosened when servicing Authorized Service Provider only parts. Make special note of each screw size and location during removal and replacement.

Bottom cover

Description	Spare part number
Bottom cover, jet black	L23174-001
Bottom cover, natural silver	L23175-001
Bottom cover, pale gold	L23176-001
Bottom cover, scarlet red	L23177-001
Bottom cover, twilight blue	L23178-001
Bottom cover, smoke gray	L23179-001
Bottom cover, snow white	L23180-001
Rubber feet, jet black	L23212-001
Rubber feet, natural silver	L23213-001
Rubber feet, pale gold	L23214-001
Rubber feet, scarlet red	L23215-001
Rubber feet, twilight blue	L23216-001
Rubber feet, smoke gray	L23217-001
Rubber feet, snow white	L23218-001

1. Turn off the computer. If you are unsure whether the computer is off or in Hibernation, turn the computer on, and then shut it down through the operating system.
2. Disconnect the power from the computer by unplugging the power cord from the computer.
3. Disconnect all external devices from the computer.

Remove the bottom cover:

1. Peel the rubber feet off the bottom of the computer **(1)**.

2. Remove the three black Phillips M2.5×6.0 screws **(2)** from under the rubber feet and the two silver Phillips M2.5×6.0 screws **(3)** from the bottom corners of the bottom cover.

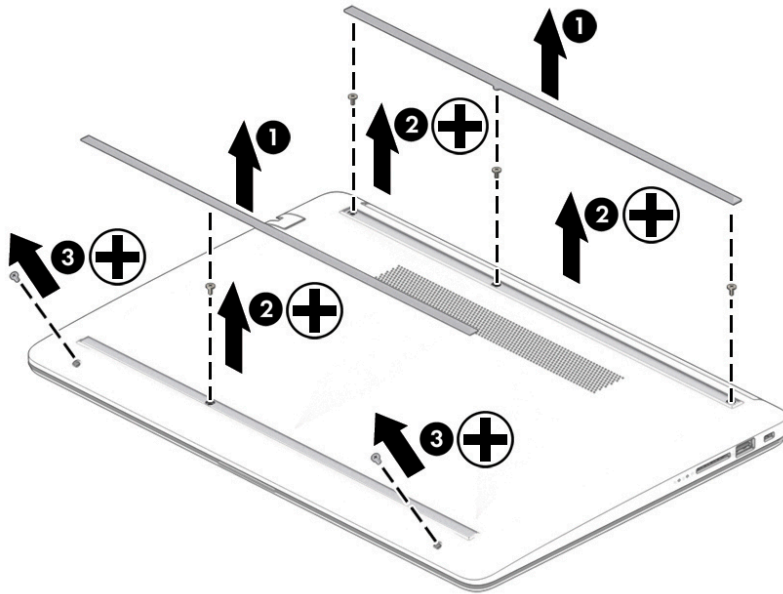

3. Starting near the power connector, use a plastic tool **(1)** to pry the bottom cover up to remove it **(2)**.



Reverse this procedure to install the bottom cover.

Battery

Description	Spare part number
Battery (3-cell, 41 WHr, 3.6 Ahr)	L11119-855

Before removing the battery, follow these steps:

1. Shut down the computer.
2. Disconnect all external devices connected to the computer.
3. Disconnect the power from the computer by first unplugging the power cord from the AC outlet and then unplugging the AC adapter from the computer.
4. Remove the bottom cover (see [Bottom cover on page 30](#)).

Remove the battery:

1. Remove the five Phillips M2.0×3.0 screws (1) that secure the battery to the computer.
2. Remove the battery from the computer (2).

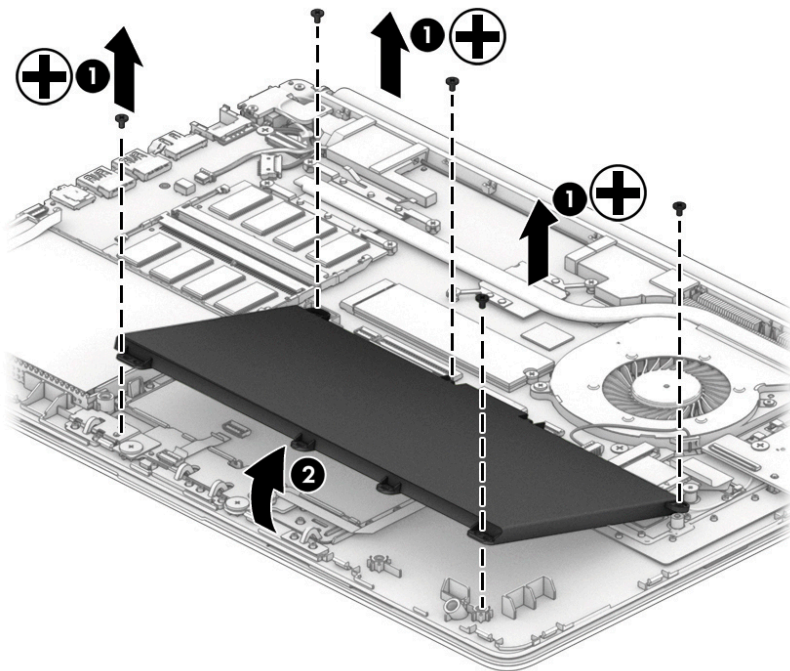

Reverse this procedure to install the battery.

When installing the battery, be sure to install screws in the proper locations. The following image shows the locations around the battery that have holes but do NOT require screws.

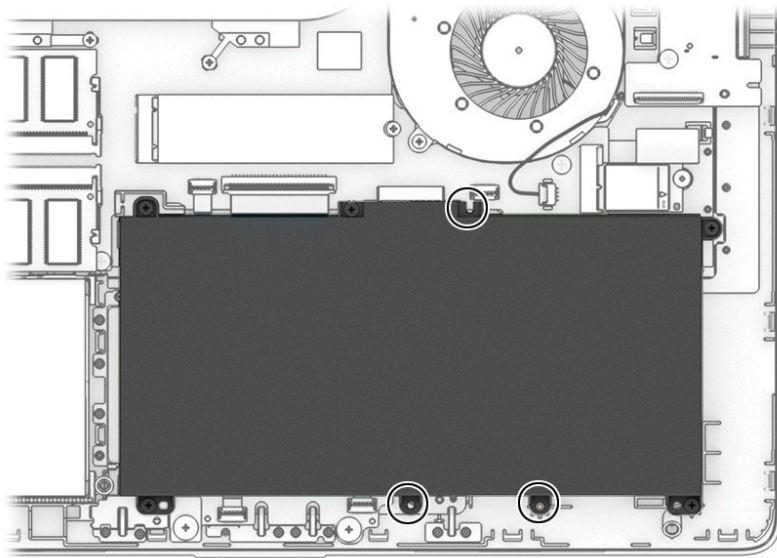

Memory

Description	Spare part number
Memory module, 8 GB	862398-855
Memory module, 4 GB	862397-859

Before removing the memory modules, follow these steps:

1. Shut down the computer.
2. Disconnect all external devices connected to the computer.
3. Disconnect the power from the computer by first unplugging the power cord from the AC outlet and then unplugging the AC adapter from the computer.
4. Remove the bottom cover (see [Bottom cover on page 30](#)).
5. Remove the battery (see [Battery on page 32](#)).

Remove the memory modules:

1. Spread the two retention clips outward **(1)** until the memory module tilts up at a 45-degree angle.
2. Grasp the edge of the memory module **(2)**, and then gently pull the module out of the slot. Use the same procedure to remove both memory modules.

CAUTION: To prevent damage to the memory module, hold the memory module by the edges only. Do not touch the components on the memory module.

To protect a memory module after removal, place it in an electrostatic-safe container.

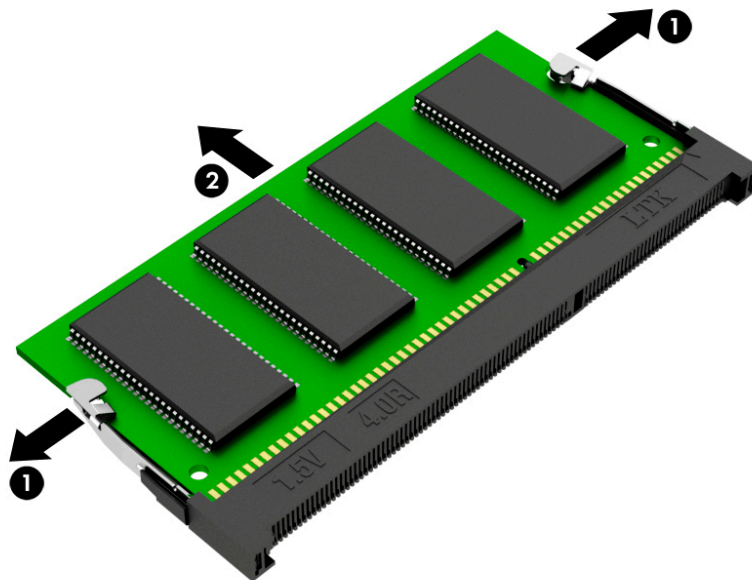

Install the memory modules:

IMPORTANT: To prevent damage to the memory module, hold the memory module by the edges only. Do not touch the components on the memory module. Do not bend the memory module.

1. Align the notched edge of the memory module with the tab in the memory module slot **(1)**.
2. Press the module into the slot until seated **(2)**.
3. Gently press down on the module edges until the side retention clips snap into place **(3)**.

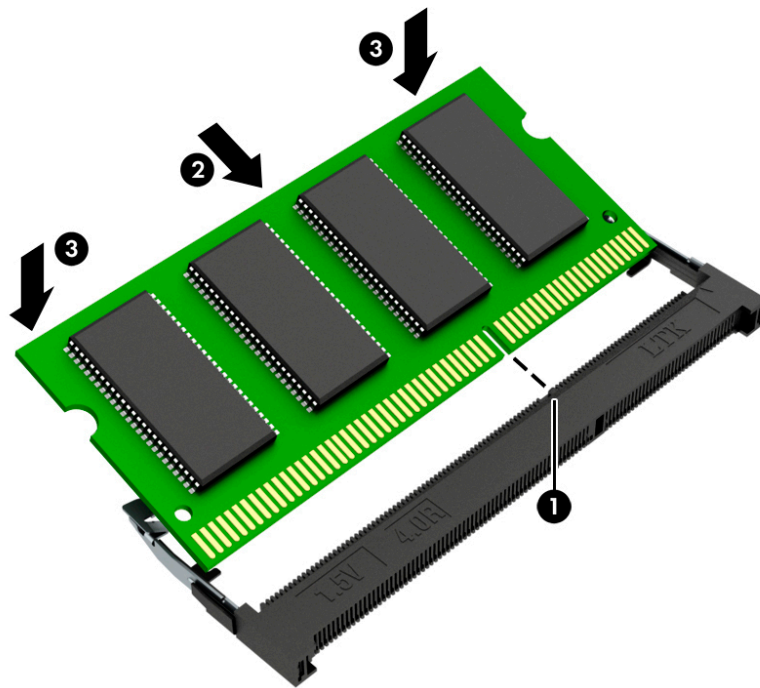

Hard drive

Description	Spare part number
Hard drive, 1 TB, 5400 rpm	762990-005
Hard drive, 500 GB, 5400 rpm	778186-005
Hard drive cover	L23219-001

Before removing the hard drive, follow these steps:

1. Shut down the computer.
2. Disconnect all external devices connected to the computer.
3. Disconnect the power from the computer by first unplugging the power cord from the AC outlet and then unplugging the AC adapter from the computer.
4. Remove the bottom cover (see [Bottom cover on page 30](#)).
5. Remove the battery (see [Battery on page 32](#)).

Remove the hard drive:

1. Disconnect the hard drive cable from the system board ZIF connector **(1)**.
2. Lift the hard drive out of the computer **(2)**.

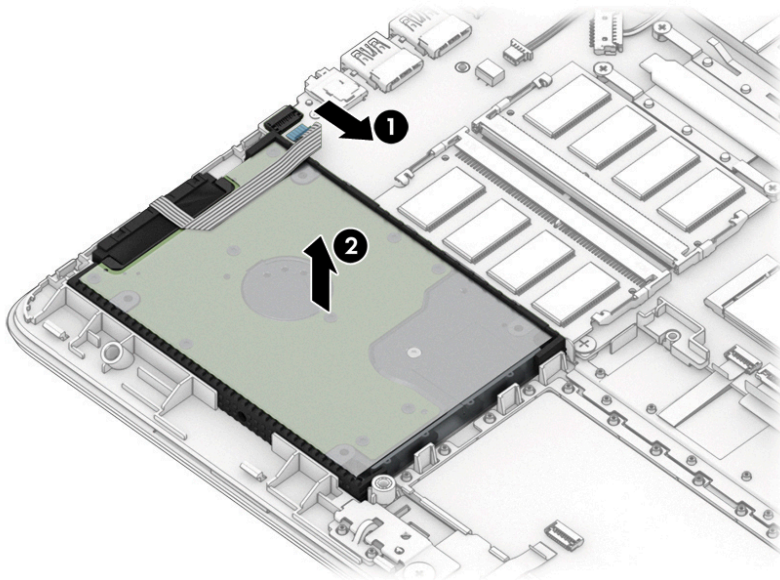

3. If it is necessary to disassemble the hard drive, pull the connector off the rear of the drive **(1)**, and then lift the cover off the drive **(2)**.

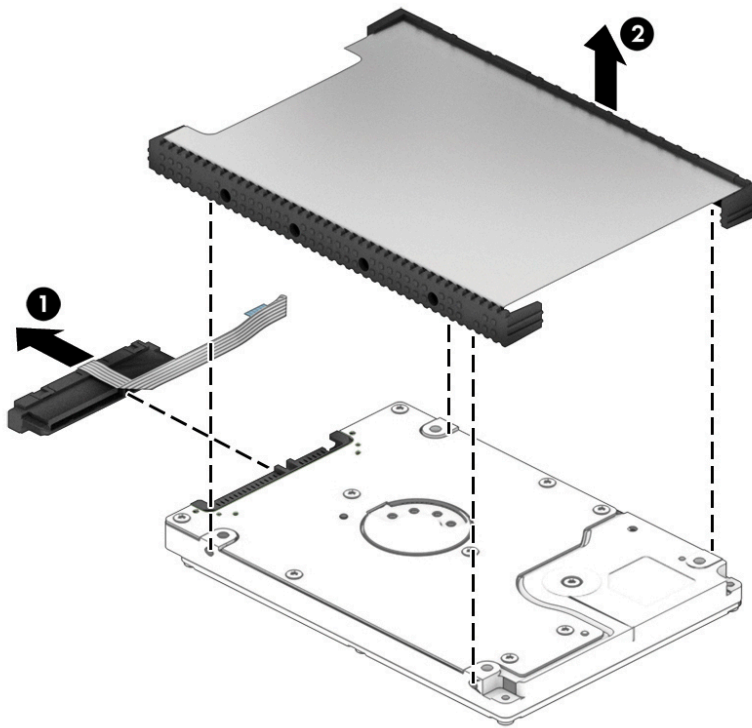

Reverse this procedure to reassemble and install the hard drive.

Solid-state drive

Description	Spare part number
512 GB, PCIe, NVMe	L23225-001
256 GB, PCIe, NVMe	L23224-001
256 GB, SATA-3, TLC	L23223-001
128 GB, SATA-3, TLC	L23222-001
Optane memory module, 16 GB	L42281-001

Before removing the solid-state drive, follow these steps:

1. Shut down the computer.
2. Disconnect all external devices connected to the computer.
3. Disconnect the power from the computer by first unplugging the power cord from the AC outlet and then unplugging the AC adapter from the computer.
4. Remove the bottom cover (see [Bottom cover on page 30](#)).
5. Remove the battery (see [Battery on page 32](#)).

Remove the solid-state drive:

- ▲ Remove the Phillips M2.0×3.0 screw **(1)**, and then pull the solid-state drive module from the socket **(2)**.

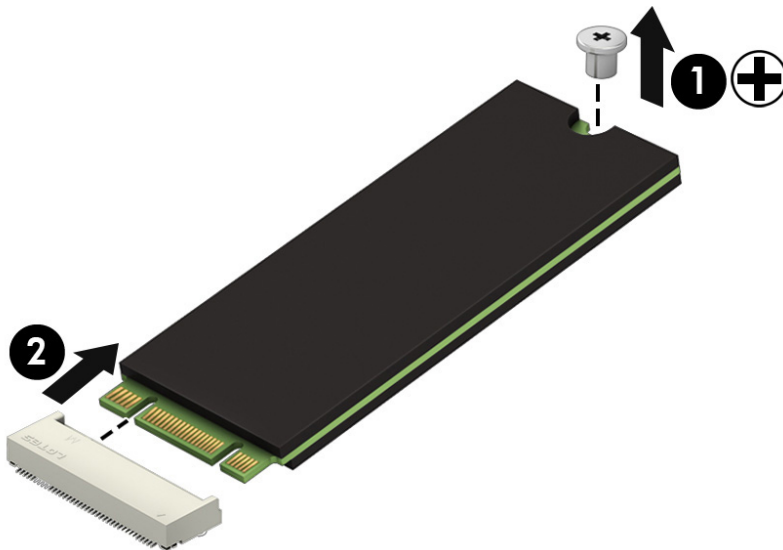

Reverse this procedure to install the solid-state drive.

WLAN module

Description	Spare part number
Intel Dual Band Wireless-AC 9461 802.11 AC 1x1 WiFi + BT5 Combo Adapter (non-vPro) (MU-MIMO supported)	L25889-005
Intel Dual band wireless-AC 3168 802.11AC 1x1 WiFi + Bluetooth 4.2 Combo Adaptor (non-vPro)	863934-855
Realtek RTL8822BE 802.11 ac 2x2 WiFi + Bluetooth 4.2 Combo Adapter (MU-MIMO supported)	924813-855
Realtek RTL8821CE 802.11 ac 1x1 WiFi + Bluetooth 4.2 Combo Adapter (MU-MIMO supported)	L17365-005
Realtek RTL8723DE 802.11 bgn 1x1 WiFi + Bluetooth 4.2 Combo Adapter	L21480-005

Before removing the WLAN, follow these steps:

1. Shut down the computer.
2. Disconnect all external devices connected to the computer.
3. Disconnect the power from the computer by first unplugging the power cord from the AC outlet and then unplugging the AC adapter from the computer.
4. Remove the bottom cover (see [Bottom cover on page 30](#)).
5. Remove the battery (see [Battery on page 32](#)).

Remove the WLAN module:

1. Disconnect the antenna cable(s) from the module **(1)**.



NOTE: Some models have only one antenna cable.

2. Remove the Phillips M2.0×3.0 screw (2), and then pull the module out of the socket (3).

Models with two antennas

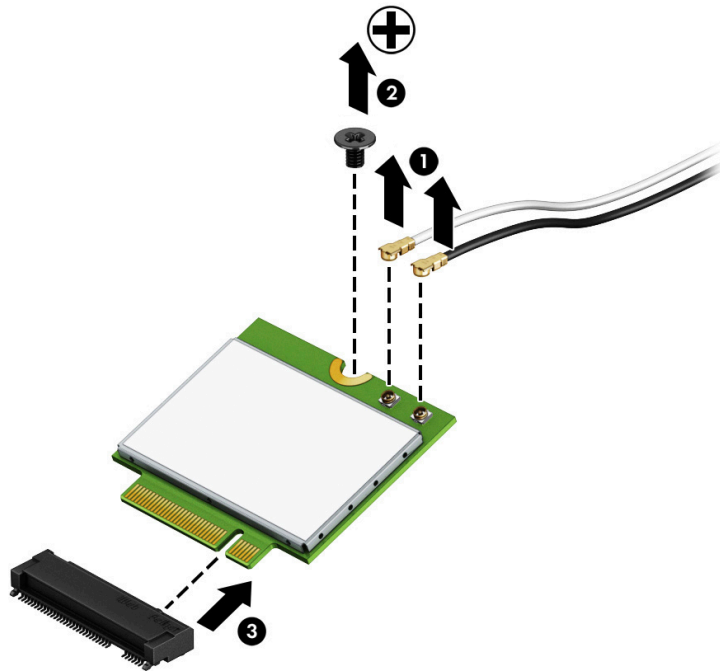

Models with one antenna

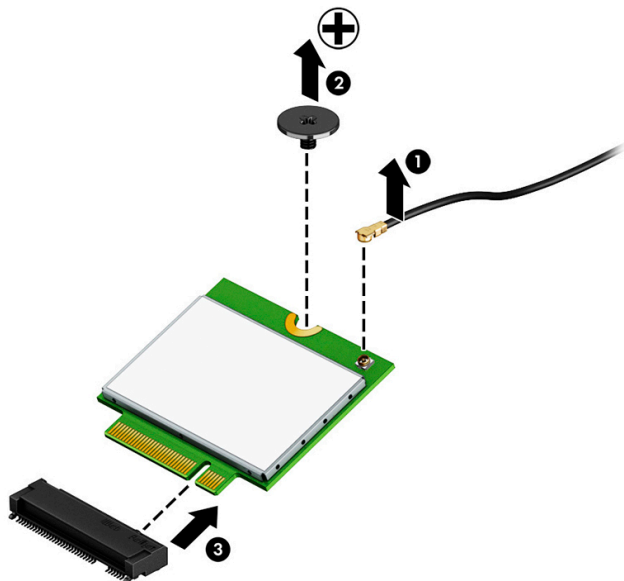

Reverse this procedure to install the WLAN module.

System board hook

Description	Spare part number
System board hook	L23206-001

 **NOTE:** Located under the battery, a black plastic piece fits around the screw boss next to the memory modules. This “hook” is unsecured and can fall out if you tilt the computer. Use the following image to determine where the hook is properly installed.

Before removing the system board hook, follow these steps:

1. Turn off the computer. If you are unsure whether the computer is off or in Hibernation, turn the computer on, and then shut it down through the operating system.
2. Disconnect the power from the computer by unplugging the power cord from the computer.
3. Disconnect all external devices from the computer.
4. Remove the bottom cover (see [Bottom cover on page 30](#)).
5. Remove the battery (see [Battery on page 32](#)).

Remove the system board hook:

- ▲ Remove the system board hook from the computer.

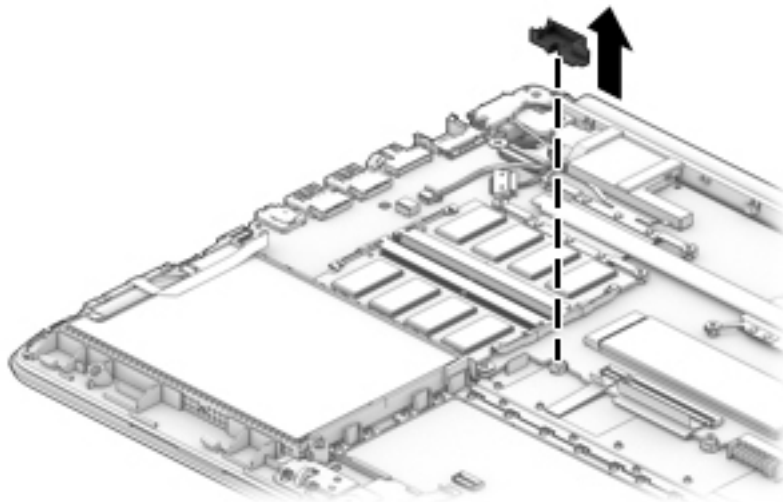

Reverse this procedure to install the system board hook.

Speakers

Description	Spare part number
Speaker Kit	L23221-001

Before removing the speakers, follow these steps:

1. Shut down the computer.
2. Disconnect all external devices connected to the computer.
3. Disconnect the power from the computer by first unplugging the power cord from the AC outlet and then unplugging the AC adapter from the computer.
4. Remove the bottom cover (see [Bottom cover on page 30](#)).
5. Remove the battery (see [Battery on page 32](#)).

Remove the speakers:

1. Disconnect the speaker cable from the system board **(1)**.
2. Lift the tape that secures the speaker cable to the system board **(2)**, and then lift the speakers from the computer **(3)**.

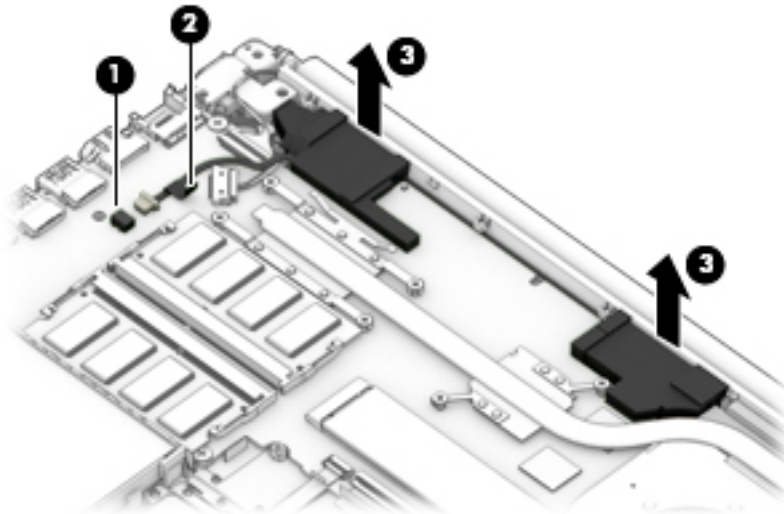

Reverse this procedure to install the speakers.

TouchPad button board

Description	Spare part number
TouchPad button board	L23197-001
TouchPad button board bracket	L23193-001
TouchPad button board cable	L23185-001

Before removing the TouchPad button board, follow these steps:

1. Shut down the computer.
2. Disconnect all external devices connected to the computer.
3. Disconnect the power from the computer by first unplugging the power cord from the AC outlet and then unplugging the AC adapter from the computer.
4. Remove the bottom cover (see [Bottom cover on page 30](#)).
5. Remove the battery (see [Battery on page 32](#)).

Remove the TouchPad button board:

1. Disconnect the TouchPad ZIF cable from the TouchPad button board **(1)**.
2. Disconnect the system board ZIF cable from the TouchPad button board **(2)**.
3. Remove the two Phillips M2.0×2.0 screws **(3)** that secure the board to the computer.
4. Lift the bracket from on top of the TouchPad button board **(4)**.
5. Lift the board and then slide it outward from under the clips that hold it on place to remove it **(5)**.

 **TIP:** The top edge of the board sits under clips. Be sure to slide the board out from under the clips to prevent damage to the board or clips.

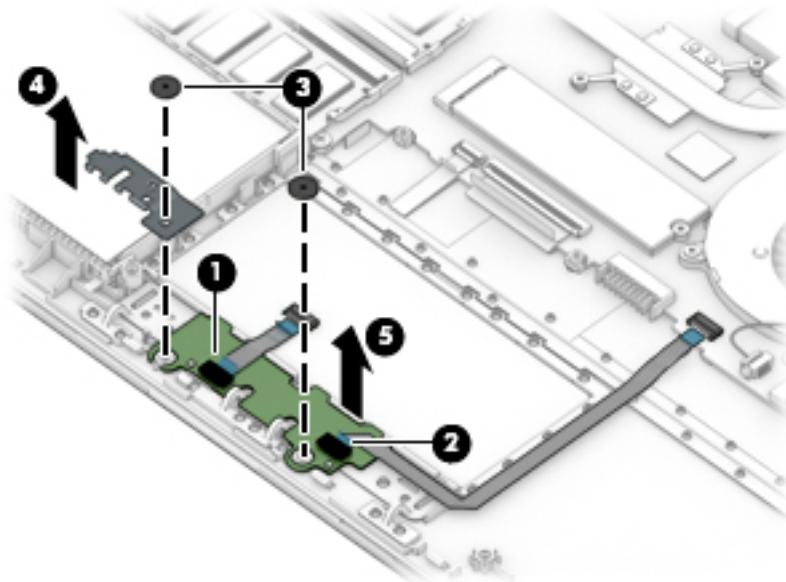

Reverse this procedure to install the TouchPad button board.

Fan

Description	Spare part number
Fan	L23189-001

Before removing the fan, follow these steps:

1. Shut down the computer.
2. Disconnect all external devices connected to the computer.
3. Disconnect the power from the computer by first unplugging the power cord from the AC outlet and then unplugging the AC adapter from the computer.
4. Remove the bottom cover (see [Bottom cover on page 30](#)).
5. Remove the battery (see [Battery on page 32](#)).

Remove the fan:

1. Disconnect the fan cable from the system board **(1)**.
2. Remove the silver Phillips M2.0×5.0 screw **(2)** that secures the fan to the computer.
3. Remove the black Phillips M2.0×3.0 screw **(3)** that secures the fan to the computer.
4. Lift the fan from the computer **(4)**.

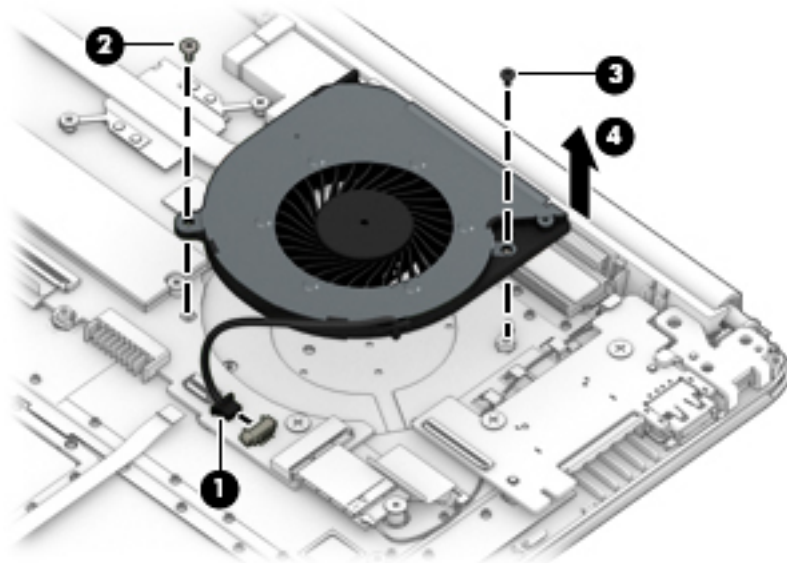

Reverse this procedure to install the fan.

Heat sink assembly

Description	Spare part number
Heat sink for use in models with Intel Core processors and integrated UMA graphics	L23192-001
Heat sink for use in models with Intel Core processors and discrete graphics	L23191-001
Heat plate for use in fanless models with Intel Pentium and Celeron processors	L23190-001

Before removing the heat sink, follow these steps:

1. Shut down the computer.
2. Disconnect all external devices connected to the computer.
3. Disconnect the power from the computer by first unplugging the power cord from the AC outlet and then unplugging the AC adapter from the computer.
4. Remove the bottom cover (see [Bottom cover on page 30](#)).
5. Remove the battery (see [Battery on page 32](#)).

To remove the heat sink assembly from products with integrated UMA graphics:

1. In the order indicated on the heat sink assembly, remove the four Phillips M2.0×3.0 screws **(1)** that secure the heat sink to the computer.
2. Lift the heat sink assembly from the computer **(2)**.

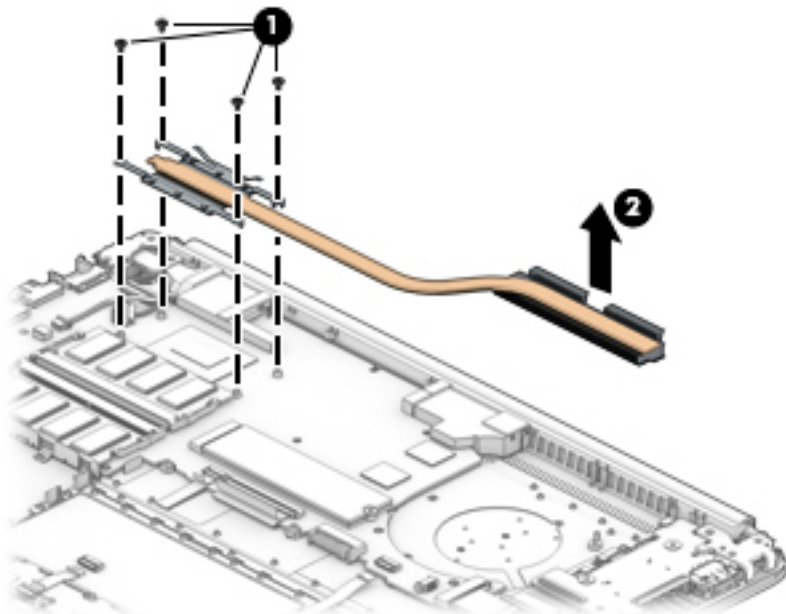

3. Thoroughly clean the thermal material from the surface of the heat sink **(1)** and associated system board component **(2)** each time the heat sink is removed. Replacement thermal material is included with the heat sink and system board spare part kits.

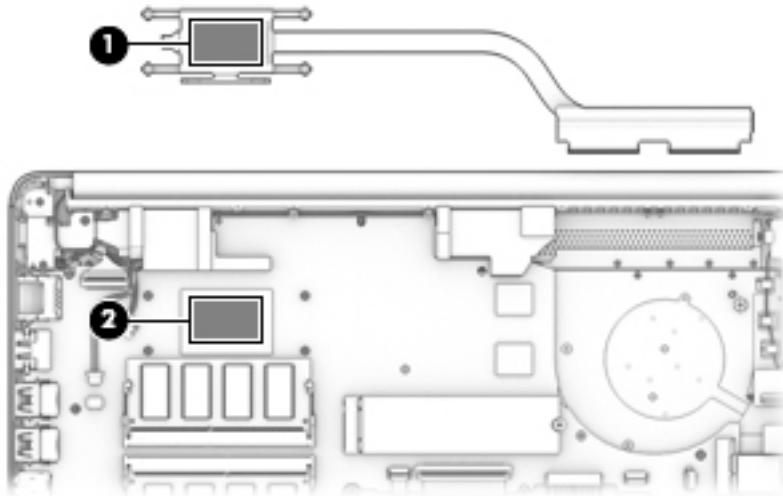

To remove the heat sink assembly from products with discrete graphics:

1. In the order indicated on the heat sink assembly, remove the six Phillips M2.0×3.0 screws **(1)** that secure the heat sink to the computer.
2. Lift the heat sink assembly from the computer **(2)**.

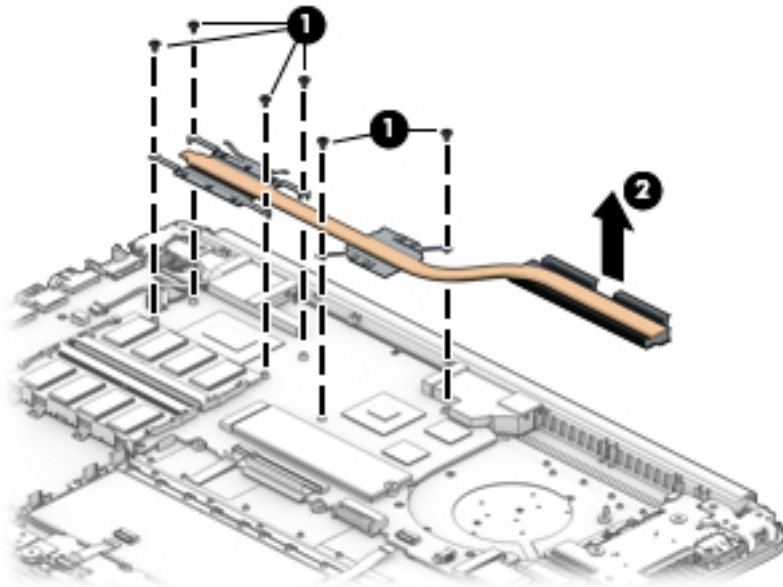

3. Thoroughly clean the thermal material from the surfaces of the heat sink **(1)(3)** and associated system board components **(2)(4)** each time the heat sink is removed. Replacement thermal material is included with the heat sink and system board spare part kits.

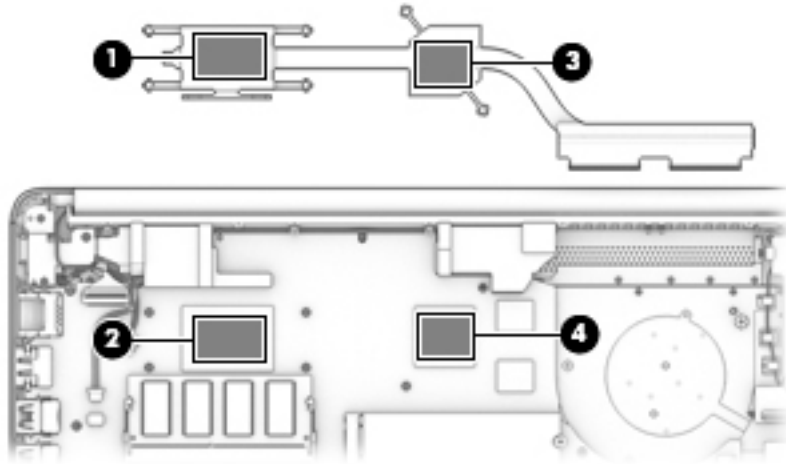

To remove the heat plate from fanless models:

1. In the order indicated on the heat plate, remove the four Phillips M2.0×3.0 screws **(1)** that secure the heat plate to the computer.
2. Lift the heat plate from the computer **(2)**.

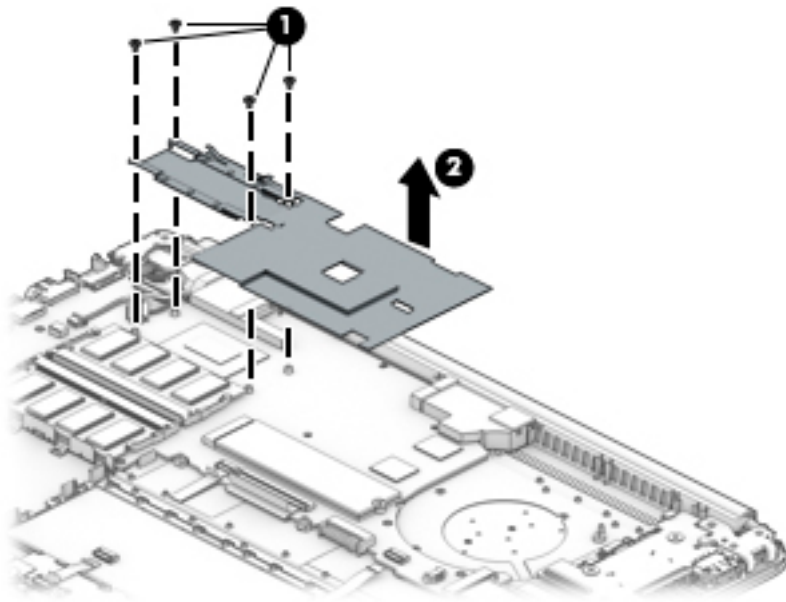

3. Thoroughly clean the thermal material from the surfaces of the heat sink **(1)(3)** and associated system board components **(2)(4)** each time the heat sink is removed. Replacement thermal material is included with the heat sink and system board spare part kits.

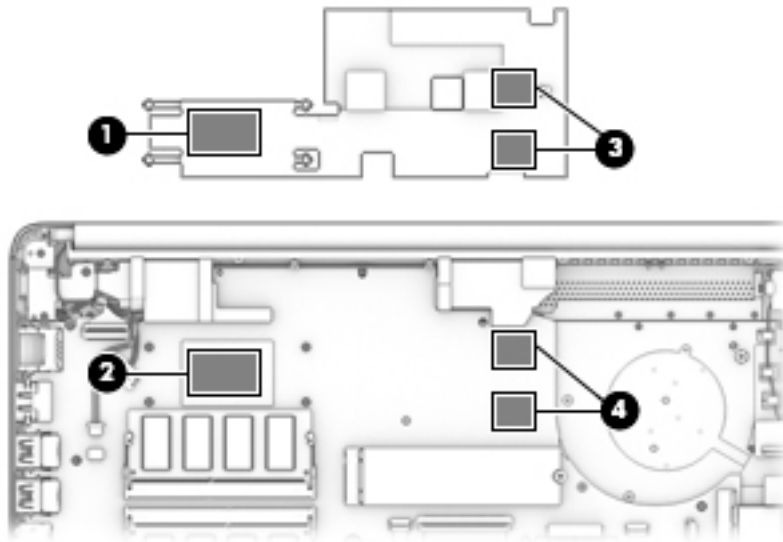

Reverse this procedure to install the heat plate or heat sink assembly.

TouchPad module

Description	Spare part number
TouchPad module	L22586-001
TouchPad module cable	L23184-001

Before removing the TouchPad module, follow these steps:

1. Shut down the computer.
2. Disconnect all external devices connected to the computer.
3. Disconnect the power from the computer by first unplugging the power cord from the AC outlet and then unplugging the AC adapter from the computer.
4. Remove the bottom cover (see [Bottom cover on page 30](#)).
5. Remove the battery (see [Battery on page 32](#)).

To remove the TouchPad module:

1. Peel the conductive tape off of the keyboard **(1)**
2. Starting in the corner, use a plastic, non-marking tool to pry up the TouchPad module to disengage the adhesive that secures it to the top cover **(2)**
3. Working around each edge, pry the TouchPad module loose, and then remove it from the computer **(3)**.

 **NOTE:** The TouchPad module may be very tight and difficult to remove.

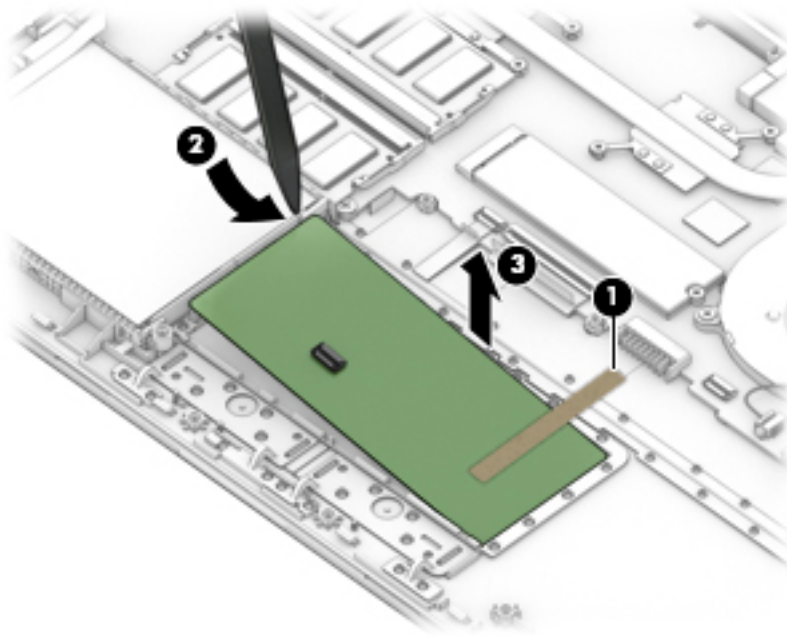

Reverse this procedure to install the TouchPad module.

 **TIP:** it must be pasted on both touchpad and the keyboard metal,

System board



NOTE: All system board spare part kits include replacement thermal material.

All system boards use the following part numbers:

xxxxxx-001: Non-Windows operating systems

xxxxxx-601: Windows operating system

Description	Spare part number
System board for use in models with discrete graphics memory:	
Intel Core i7-8565U processor with 2 GB of discrete graphics memory	L38148-xx1
Intel Core i7-8550U processor with 2 GB of discrete graphics memory	L23228-xx1
Intel Core i5-8265U processor with 4 GB of discrete graphics memory	L38149-xx1
Intel Core i5-8265U processor with 2 GB of discrete graphics memory	L38150-xx1
Intel Core i5-8250U processor with 4 GB of discrete graphics memory	L23229-xx1
Intel Core i5-8250U processor with 2 GB of discrete graphics memory	L23227-xx1
Intel Core i3-7020U processor with 2 GB of discrete graphics memory	L23226-xx1
System board for use in models with UMA graphics memory:	
Intel Core i7-8550U processor	L23233-xx1
Intel Core i7-8265U processor	L38151-xx1
Intel Core i5-8250U processor	L23232-xx1
Intel Core i3-8130U processor	L23231-xx1
Intel Core i7-7500U processor	L42280-xx1
Intel Core i5-7200U processor	L42279-xx1
Intel Core i3-7100U processor	L42278-xx1
Intel Core i3-7020U processor	L23230-xx1
Intel Pentium N5000 processor	L23236-xx1
Intel Celeron N4000 processor	L23234-xx1
Intel Celeron N4000 processor, models with 64 GB eMMC memory	L23235-xx1

Before removing the system board, follow these steps:

1. Shut down the computer.
2. Disconnect all external devices connected to the computer.
3. Disconnect the power from the computer by first unplugging the power cord from the AC outlet and then unplugging the AC adapter from the computer.
4. Remove the following components:
 - a. Bottom cover (see [Bottom cover on page 30](#))
 - b. Battery (see [Battery on page 32](#))

- c. Hard drive (see [Hard drive on page 36](#))
- d. Solid-state drive (see [Solid-state drive on page 38](#))
- e. WLAN module (see [WLAN module on page 39](#))
- f. Memory modules (see [Memory on page 34](#))
- g. Fan (see [Fan on page 44](#))

Remove the system board:

 **IMPORTANT:** Make special note of each screw size and location during removal and replacement

1. Disconnect the following cables from the system board:

- (1): Hard drive cable
- (2): Display cable
- (3): Power connector cable
- (4): Speaker cable
- (5): Keyboard backlight cable
- (6): Keyboard cable
- (7): TouchPad button board cable
- (8): USB board cable

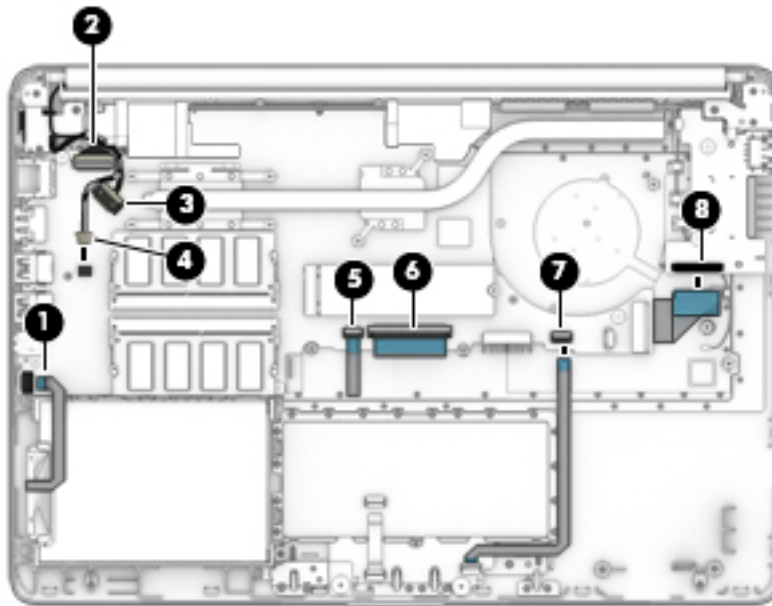

2. Remove the black Phillips M2.0×3.0 screw **(1)**, and the four silver Phillips M2.0×2.0 screws **(2)** that secure the system board to the computer.

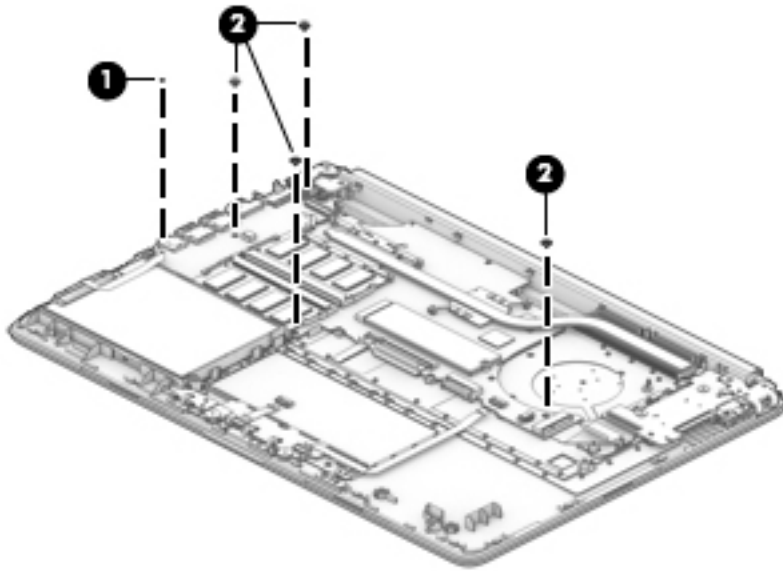

3. Lift the left side of the system board **(1)**, and then remove it from the computer **(2)**.

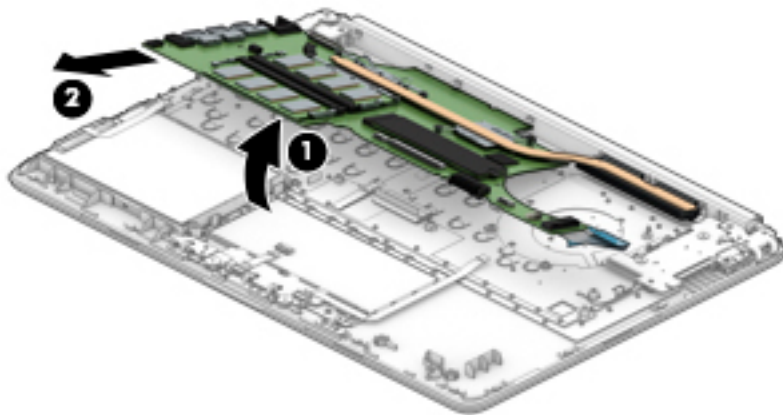

Reverse this procedure to install the system board.

When installing the system board, first insert the bottom (side closest to the display hinge cover) down and into the computer. Make sure to place the system board under the two tabs/clips, and to insert the plastic post into the hole in the system board.

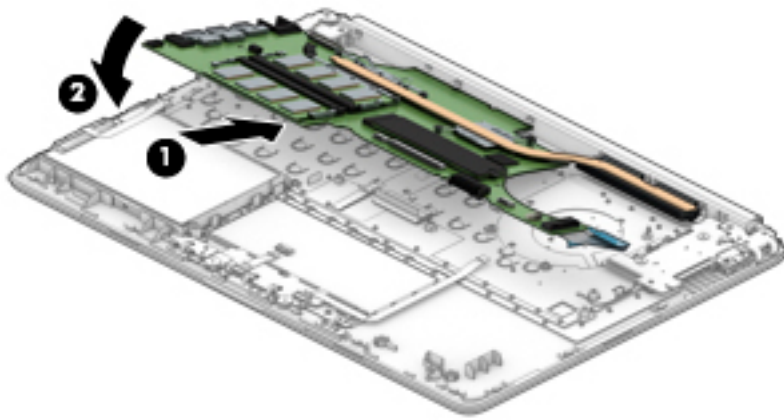

Power connector cable (DC-in)

Description	Spare part number
Power connector cable	L23188-001

Before removing the power connector cable, follow these steps:

1. Turn off the computer. If you are unsure whether the computer is off or in Hibernation, turn the computer on, and then shut it down through the operating system.
2. Disconnect the power from the computer by unplugging the power cord from the computer.
3. Disconnect all external devices from the computer.
4. Remove the bottom cover (see [Bottom cover on page 30](#)).
5. Remove the battery (see [Battery on page 32](#)).
6. Remove the display (see [Display assembly on page 56](#)).

Remove the power connector cable:

1. Disconnect the power connector cable from the system board **(1)**.
2. Remove the cable from the clip **(2)**.
3. Remove the power connector cable out of the computer **(3)**.

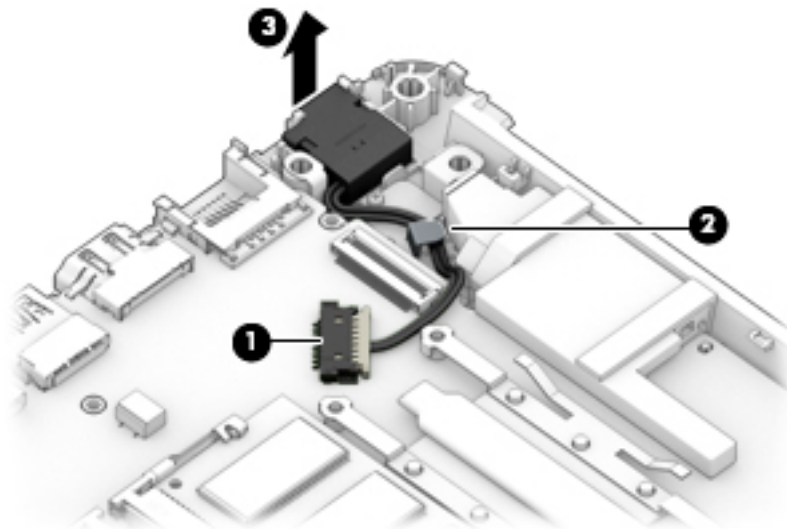

Reverse this procedure to install the power connector cable.

USB/card reader/power button board

Description	Spare part number
USB/card reader/power button board	L23196-001
USB/card reader/power button board cable	L23186-001

Before removing the USB/card reader/power button board, follow these steps:

1. Turn off the computer. If you are unsure whether the computer is off or in Hibernation, turn the computer on, and then shut it down through the operating system.
2. Disconnect the power from the computer by unplugging the power cord from the computer.
3. Disconnect all external devices from the computer.
4. Remove the bottom cover (see [Bottom cover on page 30](#)).
5. Remove the battery (see [Battery on page 32](#)).
6. Remove the display (see [Display assembly on page 56](#)).

Remove the USB/card reader/power button board:

1. Disconnect the cable from the ZIF connector on the USB/card reader/power button board **(1)**.
2. Remove the two Phillips M2.0×3.0 screws **(2)**, and then remove the board from the computer **(3)**.

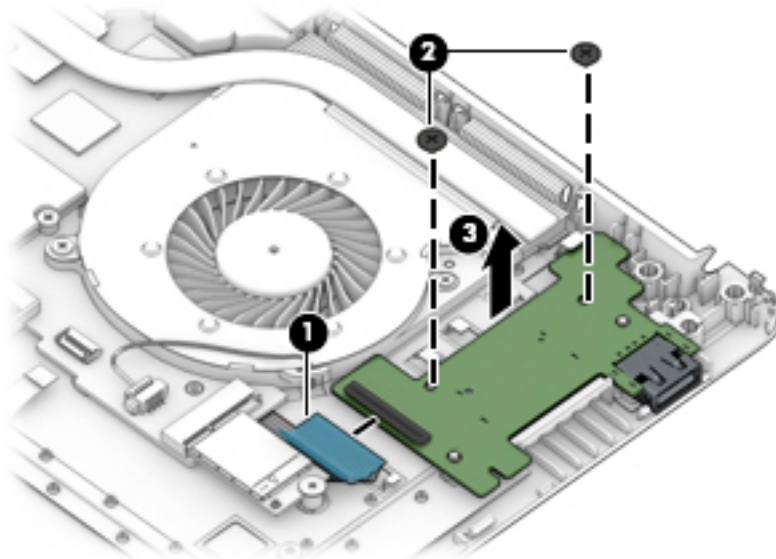

Reverse this procedure to replace the USB/card reader/power button board.

Display assembly

Full hinge-up displays are not spared. Displays are spared only at the subcomponent level.

Before removing the display panel, follow these steps:

1. Shut down the computer. If you are unsure whether the computer is off or in Hibernation, turn the computer on, and then shut it down through the operating system.
2. Disconnect all external devices connected to the computer.
3. Disconnect the power from the computer by first unplugging the power cord from the AC outlet, and then unplugging the AC adapter from the computer.
4. Remove the bottom cover (see [Bottom cover on page 30](#)).
5. Remove the battery (see [Battery on page 32](#)).

Remove the display assembly:

1. Disconnect the display cable from the system board **(1)**.
2. Disconnect the antenna cables from the WLAN module **(2)**.
3. Remove the antenna cables from the clips in the speaker **(3)**.
4. Pull the antenna cables under USB/card reader/power button board **(4)**.

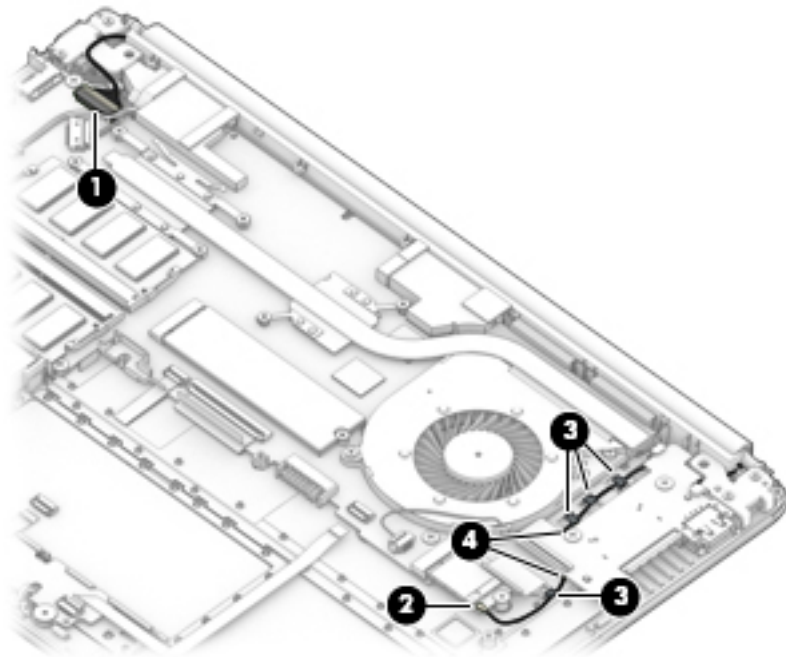

5. Remove the four Phillips M2.5×6.0 screws **(1)** from the display hinges.
6. Rotate the hinges upward **(2)**.

7. Separate the display from the computer (3).

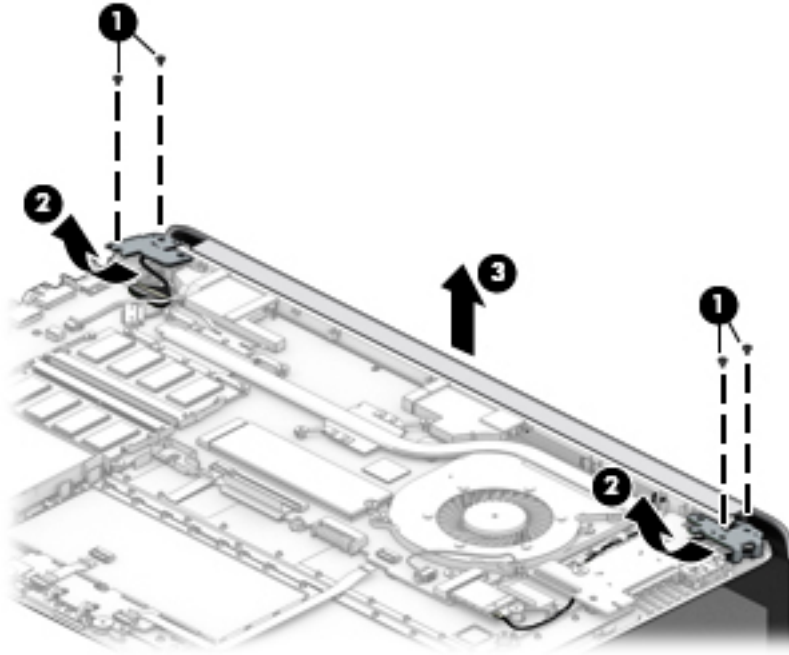

Remove the display assembly subcomponents:

1. If it is necessary to replace the display bezel:
 - a. If you need to remove the display bezel, flex the top (1) of the bezel, the inside edges of the left and right sides (2), and then the bottom (3) of the bezel until it disengages from the display enclosure.
 - b. Remove the bezel (4).

The display bezel is available using spare part number L23181-001.

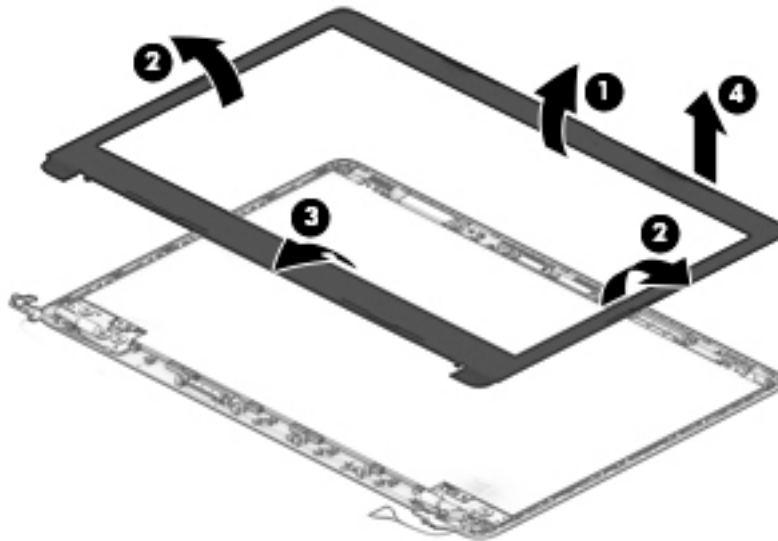

2. If it is necessary to replace the camera/microphone module:

- a. Detach the camera module **(1)** from the display back cover. (The module is attached with double-sided adhesive.)

The HD camera module is available using spare part number L23237-001.

The VGA camera module is available using spare part number L23238-001.

- b. Disconnect the cable **(2)** from the camera/microphone module.

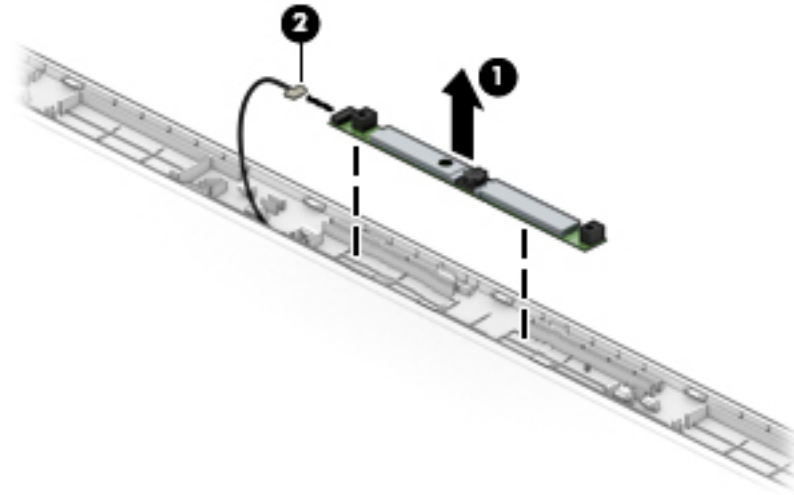

3. If it is necessary to replace the display panel:

 **IMPORTANT:** HD panels are secured to the display enclosure with screws. FHD panels are secured with tape.

- a. **HD panels:**

Remove the four Phillips M2.0×3.0 screws that secure the panel to the display enclosure.

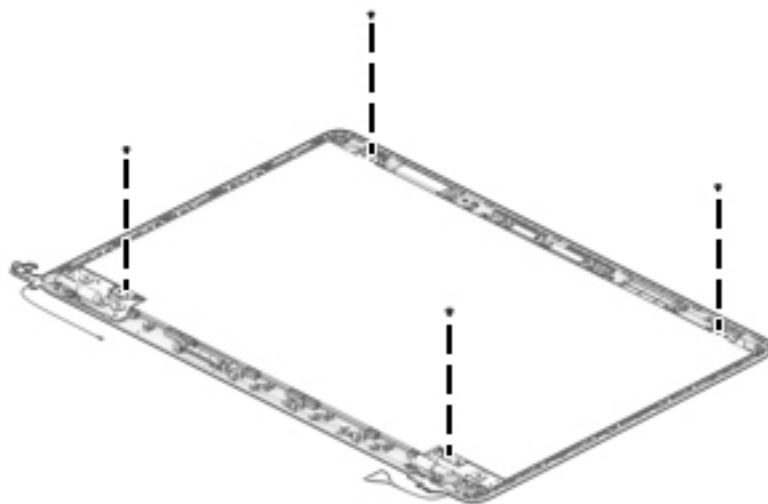

FHD panels:

- b. Pull the tape out from behind the left and right sides of the panel.

 **NOTE:** You have to pull on the tape multiple times before it is completely removed.

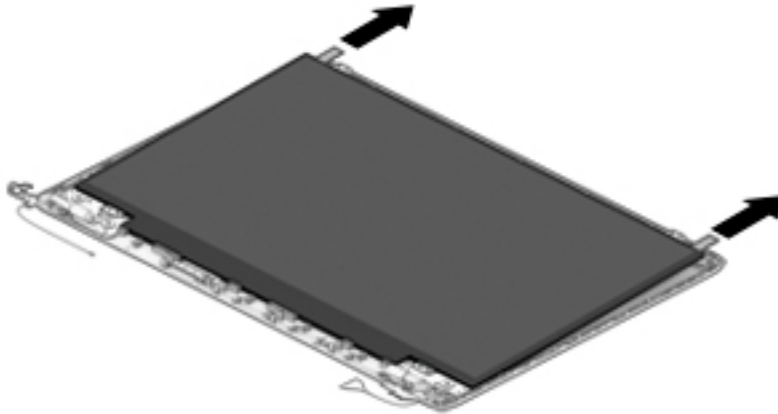

- c. **HD and FHD panels:**

Swing the top edge of the display panel forward and position the panel upside down next to the display enclosure (1).

- d. Release the adhesive support strip (2) that secures the display panel cable connector to the display panel.
- e. Disconnect the display panel cable (3) from the display panel.

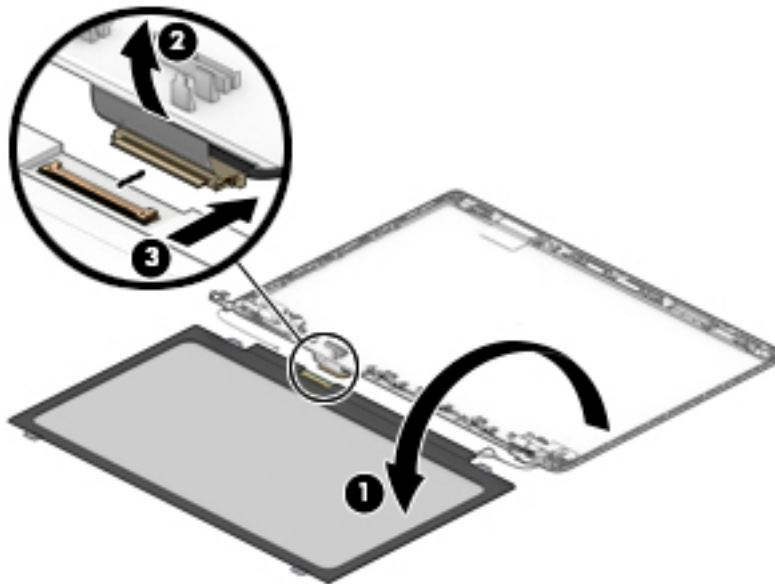

- f. Remove the display panel.

Raw display panels are available using the following spare part numbers:

L23208-001: FHD, anti glare

L42787-001: FHD, anti glare, AGOOC

L23209-001: FHD, BrightView

L23210-001: HD, anti glare

L23211-001: HD, BrightView

- g.** To correctly install the stretchable adhesive tape when replacing a narrow bezel FHD display panel, install the tape on the left and right sides of the display enclosure (**1**) with the end of the tape at the right angle marks (**2**), and then remove the paper from the tape (**3**).

Display panel stretchable adhesive tape is available using spare part number L23207-001.

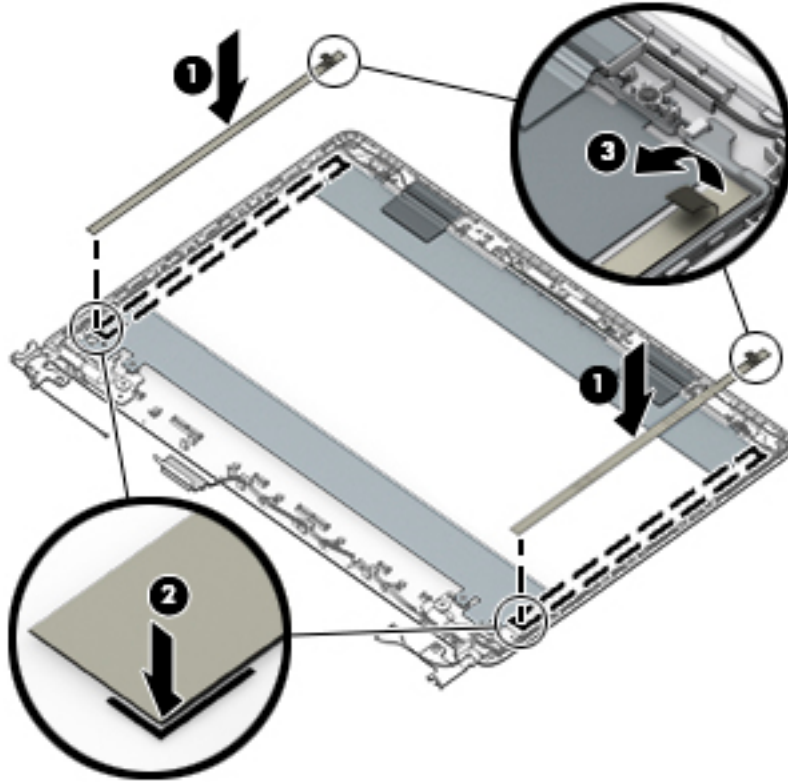

4. If it is necessary to replace the hinge cover, use a plastic, non-marking tool to pull up on the side of the hinge cover **(1)**, and then remove it **(2)**.

Hinge covers are available using the following spare part numbers:

L23199-001: Jet black

L23200-001: Natural silver

L23201-001: Pale gold

L23202-001: Scarlet red

L23203-001: Twilight blue

L23204-001: Smoke gray

L23205-001: Snow white



When replacing the hinge cover, make sure the hinges rotate downward as far as they can go. Align the cover **(1)**, and then start from above and rotate the cover downward onto the hinges **(2)**. Make sure the clips snap into place along the bottom of the display cover.

5. If it is necessary to replace the display hinges:
 - a. Remove the six Phillips M2.5×2.5 broad head screws **(1)** from the bottom of the hinges.

- b. Remove the display hinges (2).

The display hinges are available using spare part number L23194-001 for models with an HD display panel and L23195-001 for models with an FHD display panel.

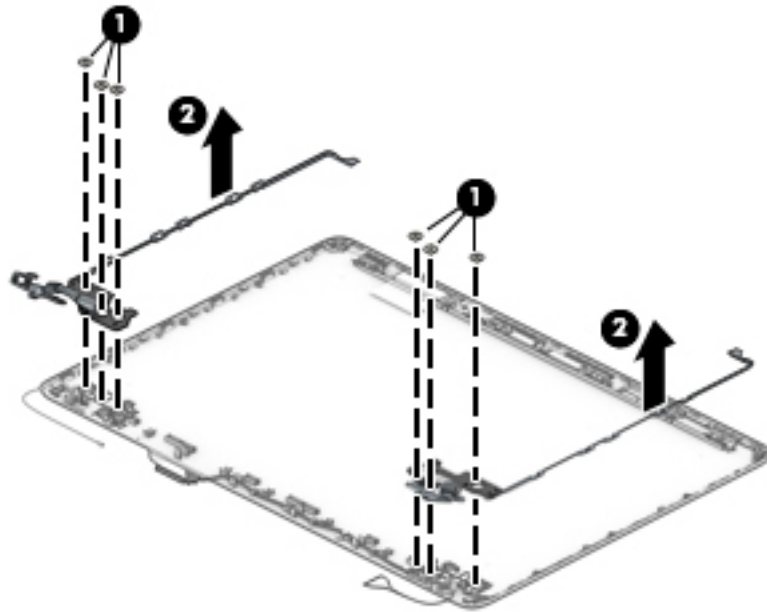

6. If it is necessary to replace the display panel cable:

- a. Release the cable from the retention clips (1) and routing channel built into the bottom edge and sides of the display enclosure.
- b. Remove the display panel cable (2).

The display panel cable is available using the following spare part numbers:

- L23182-001 – HD display panel
- L23183-001 – FHD display panel

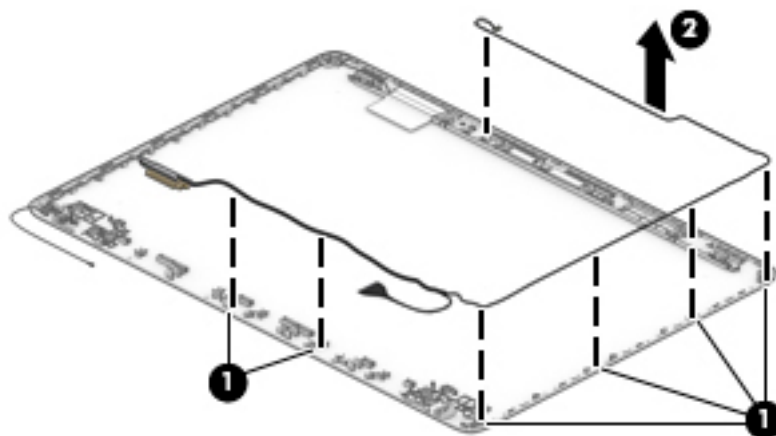

7. If it is necessary to replace the wireless antenna cables and transceivers:

- a. Release the wireless antenna cables from the retention clips and routing channel built into the side of the display enclosure (1).

- b.** Release the antenna from the display enclosure **(2)**.

Antennas are available using the following spare part numbers:

L23158-001: Single antenna for use in models with an HD panel

L23159-001: Dual antennas for use in models with an HD panel

L24037-001: Single antenna for use in models with an FHD panel

L24038-001: Dual antennas for use in models with an FHD panel

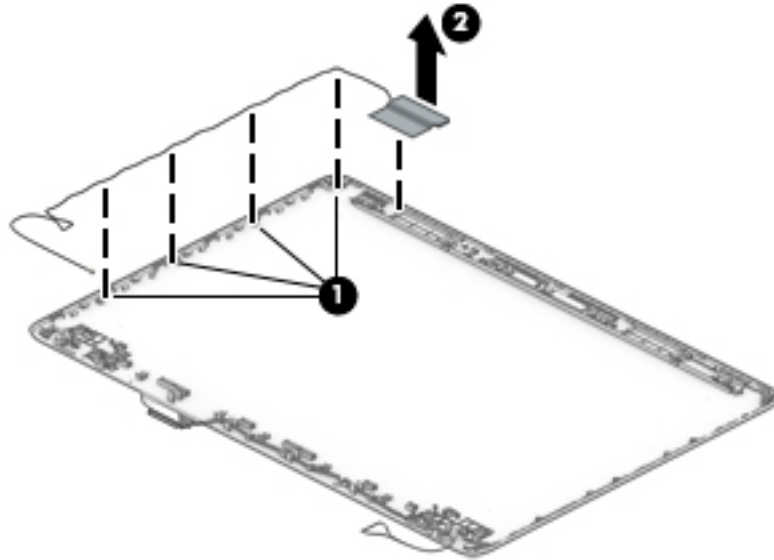

Use the following image to determine proper cable routing in the display of the antenna cable **(1)** and display cable **(2)**.

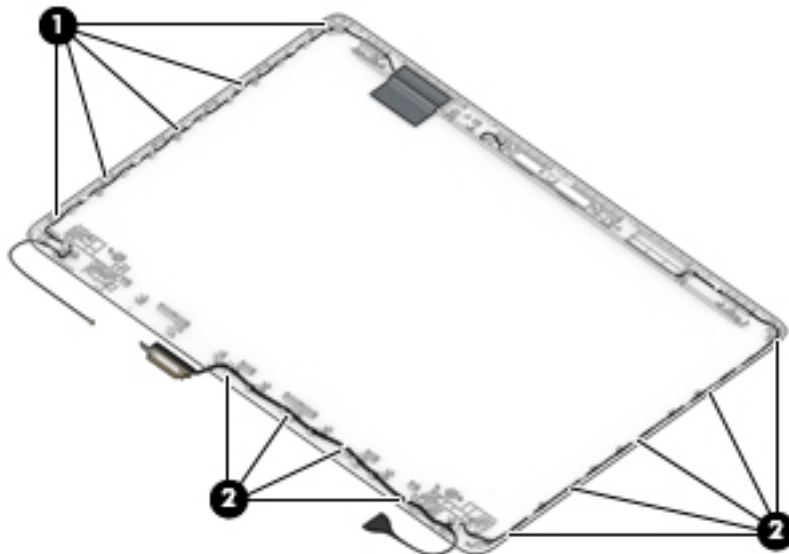

The display rear cover is available using the following spare part numbers:

L23160-001: Jack black, for models with an HD display panel

L23161-001: Natural silver, for models with an HD display panel

L23162-001: Pale gold, for models with an HD display panel

L23163-001: Scarlet red, for models with an HD display panel

L23164-001: Twilight blue, for models with an HD display panel

L23165-001: Smoke gray, for models with an HD display panel

L23166-001: Snow white, for models with an HD display panel

L23167-001: Jack black, for models with an FHD display panel

L23168-001: Natural silver, for models with an FHD display panel

L23169-001: Pale gold, for models with an FHD display panel

L23170-001: Scarlet red, for models with an FHD display panel

L23171-001: Twilight blue, for models with an FHD display panel

L23172-001: Smoke gray, for models with an FHD display panel

L23173-001: Snow white, for models with an FHD display panel

Reverse these procedures to reassemble and install the display assembly components.

Top cover with keyboard

The top cover with keyboard remains after removing all other spared parts from the computer.

In this section, the first table provides the main spare part number for the keyboards. The second table provides the country codes.

Description	Spare part number
Keyboard, no backlight, jet black	L23239-xx1
Keyboard, no backlight, snow white	L23240-xx1
Keyboard, no backlight, ash silver	L23241-xx1
Keyboard, backlit, ash silver	L23242-xx1

For use in country or region	Spare part number	For use in country or region	Spare part number	For use in country or region	Spare part number
Belgium	-A41	Italy	-061	South Korea	-AD1
Bulgaria	-261	Latin America	-161	Spain	-071
Canada	-DB1	The Netherlands	-B31	Switzerland	-BG1
Denmark, Finland, and Norway	-DH1	Portugal	-131	Taiwan	-AB1
France	-051	Romania	-271	Thailand	-281
Germany	-041	Russia	-251	Turkey	-141
Greece	-151	Saudi Arabia	-171	United Kingdom	-031
Hungary	-211	Slovenia	-BA1	United States	-001
Israel	-BB1				

6 Using Setup Utility (BIOS)

Setup Utility, or Basic Input/Output System (BIOS), controls communication between all the input and output devices on the system (such as disk drives, display, keyboard, mouse, and printer). Setup Utility (BIOS) includes settings for the types of devices installed, the startup sequence of the computer, and the amount of system and extended memory.

 **NOTE:** To start Setup Utility on convertible computers, your computer must be in notebook mode and you must use the keyboard attached to your notebook.

Starting Setup Utility (BIOS)

 **CAUTION:** Use extreme care when making changes in Setup Utility (BIOS). Errors can prevent the computer from operating properly.

- ▲ Turn on or restart the computer, quickly press `esc`, and then press `f10`.

Updating Setup Utility (BIOS)

Updated versions of Setup Utility (BIOS) may be available on the HP website.

Most BIOS updates on the HP website are packaged in compressed files called *SoftPaqs*.

Some download packages contain a file named `Readme.txt`, which contains information regarding installing and troubleshooting the file.

Determining the BIOS version

To decide whether you need to update Setup Utility (BIOS), first determine the BIOS version on your computer.

To reveal the BIOS version information (also known as *ROM date* and *System BIOS*), use one of these options.

- HP Support Assistant
 1. Type `support` in the taskbar search box, and then select the **HP Support Assistant** app.
– or –
Select the question mark icon in the taskbar.
 2. Select **My notebook**, and then select **Specifications**.
- Setup Utility (BIOS)
 1. Start Setup Utility (BIOS) (see [Starting Setup Utility \(BIOS\) on page 66](#)).
 2. Select **Main**, and then make note of the BIOS version.
 3. Select **Exit**, select one of the options, and then follow the on-screen instructions.

To check for later BIOS versions, see [Downloading a BIOS update on page 67](#).

Downloading a BIOS update

 **CAUTION:** To reduce the risk of damage to the computer or an unsuccessful installation, download and install a BIOS update only when the computer is connected to reliable external power using the AC adapter. Do not download or install a BIOS update while the computer is running on battery power, docked in an optional docking device, or connected to an optional power source. During the download and installation, follow these instructions:

- Do not disconnect power from the computer by unplugging the power cord from the AC outlet.
- Do not shut down the computer or initiate Sleep.
- Do not insert, remove, connect, or disconnect any device, cable, or cord.

 **NOTE:** If your computer is connected to a network, consult the network administrator before installing any software updates, especially system BIOS updates.

1. Type `support` in the taskbar search box, and then select the **HP Support Assistant** app.
– or –
Select the question mark icon in the taskbar.
2. Select **Updates**, and then select **Check for updates and messages**.
3. Follow the on-screen instructions.
4. At the download area, follow these steps:
 - a. Identify the most recent BIOS update and compare it to the BIOS version currently installed on your computer. If the update is more recent than your BIOS version, make a note of the date, name, or other identifier. You may need this information to locate the update later, after it has been downloaded to your hard drive.
 - b. Follow the on-screen instructions to download your selection to the hard drive.

Make a note of the path to the location on your hard drive where the BIOS update is downloaded. You will need to access this path when you are ready to install the update.

BIOS installation procedures vary. Follow any instructions that appear on the screen after the download is complete. If no instructions appear, follow these steps:

1. Type `file` in the taskbar search box, and then select **File Explorer**.
2. Select your hard drive designation. The hard drive designation is typically Local Disk (C:).
3. Using the hard drive path you recorded earlier, open the folder that contains the update.
4. Double-click the file that has an `.exe` extension (for example, `filename.exe`).

The BIOS installation begins.
5. Complete the installation by following the on-screen instructions.

 **NOTE:** After a message on the screen reports a successful installation, you can delete the downloaded file from your hard drive.

7 Using HP PC Hardware Diagnostics

Using HP PC Hardware Diagnostics Windows (select products only)

HP PC Hardware Diagnostics Windows is a Windows-based utility that allows you to run diagnostic tests to determine whether the computer hardware is functioning properly. The tool runs within the Windows operating system in order to diagnose hardware failures.

If HP PC Hardware Diagnostics Windows is not installed on your computer, first you must download and install it. To download HP PC Hardware Diagnostics Windows, see [Downloading HP PC Hardware Diagnostics Windows on page 68](#).

After HP PC Hardware Diagnostics Windows is installed, follow these steps to access it from HP Help and Support or HP Support Assistant.

1. To access HP PC Hardware Diagnostics Windows from HP Help and Support:
 - a. Select the **Start** button, and then select **HP Help and Support**.
 - b. Right-click **HP PC Hardware Diagnostics Windows**, select **More**, and then select **Run as administrator**.

– or –

To access HP PC Hardware Diagnostics Windows from HP Support Assistant:

- a. Type `support` in the taskbar search box, and then select the **HP Support Assistant** app.
 - or –
 - Select the question mark icon in the taskbar.
 - b. Select **Troubleshooting and fixes**.
 - c. Select **Diagnostics**, and then select **HP PC Hardware Diagnostics Windows**.
2. When the tool opens, select the type of diagnostic test you want to run, and then follow the on-screen instructions.



NOTE: If you need to stop a diagnostic test at any time, select **Cancel**.

3. When HP PC Hardware Diagnostics Windows detects a failure that requires hardware replacement, a 24-digit Failure ID code is generated. For assistance in correcting the problem, contact support, and then provide the Failure ID code.

Downloading HP PC Hardware Diagnostics Windows

- The HP PC Hardware Diagnostics Windows download instructions are provided in English only.
- You must use a Windows computer to download this tool because only .exe files are provided.

Downloading the latest HP PC Hardware Diagnostics Windows version

To download HP PC Hardware Diagnostics Windows, follow these steps:

1. Go to <http://www.hp.com/go/techcenter/pcdiags>. The HP PC Diagnostics home page is displayed.
2. In the **HP PC Hardware Diagnostics** section, select **Download**, and then select a location on your computer or a USB flash drive.

The tool is downloaded to the selected location.

Downloading HP Hardware Diagnostics Windows by product name or number (select products only)

 **NOTE:** For some products, it may be necessary to download the software to a USB flash drive by using the product name or number.

To download HP PC Hardware Diagnostics Windows by product name or number, follow these steps:

1. Go to <http://www.hp.com/support>.
2. Select **Get software and drivers**, select your type of product, and then enter the product name or number in the search box that is displayed.
3. In the **HP PC Hardware Diagnostics** section, select **Download**, and then select a location on your computer or a USB flash drive.

The tool is downloaded to the selected location.

Installing HP PC Hardware Diagnostics Windows

To install HP PC Hardware Diagnostics Windows, follow these steps:

- ▲ Navigate to the folder on your computer or the USB flash drive where the .exe file was downloaded, double-click the .exe file, and then follow the on-screen instructions.

Using HP PC Hardware Diagnostics UEFI

 **NOTE:** For Windows 10 S computers, you must use a Windows computer and a USB flash drive to download and create the HP UEFI support environment because only .exe files are provided. For more information, see [Downloading HP PC Hardware Diagnostics UEFI to a USB flash drive on page 70](#).

HP PC Hardware Diagnostics UEFI (Unified Extensible Firmware Interface) allows you to run diagnostic tests to determine whether the computer hardware is functioning properly. The tool runs outside the operating system so that it can isolate hardware failures from issues that are caused by the operating system or other software components.

If your PC will not boot into Windows, you can use HP PC Hardware Diagnostics UEFI to diagnose hardware issues.

When HP PC Hardware Diagnostics UEFI detects a failure that requires hardware replacement, a 24-digit Failure ID code is generated. For assistance in correcting the problem, contact support, and provide the Failure ID code.

 **NOTE:** To start diagnostics on a convertible computer, your computer must be in notebook mode, and you must use the attached keyboard.

 **NOTE:** If you need to stop a diagnostic test, press `esc`.

Starting HP PC Hardware Diagnostics UEFI

To start HP PC Hardware Diagnostics UEFI, follow these steps:

1. Turn on or restart the computer, and quickly press *esc*.
2. Press *f2*.

The BIOS searches three places for the diagnostic tools, in the following order:

- a. Connected USB flash drive



NOTE: To download the HP PC Hardware Diagnostics UEFI tool to a USB flash drive, see [Downloading the latest HP PC Hardware Diagnostics UEFI version on page 70](#).

- b. Hard drive

- c. BIOS

3. When the diagnostic tool opens, select a language, select the type of diagnostic test you want to run, and then follow the on-screen instructions.

Downloading HP PC Hardware Diagnostics UEFI to a USB flash drive

Downloading HP PC Hardware Diagnostics UEFI to a USB flash drive can be useful in the following situations:

- HP PC Hardware Diagnostics UEFI is not included in the preinstall image.
- HP PC Hardware Diagnostics UEFI is not included in the HP Tool partition.
- The hard drive is damaged.



NOTE: The HP PC Hardware Diagnostics UEFI download instructions are provided in English only, and you must use a Windows computer to download and create the HP UEFI support environment because only .exe files are provided.

Downloading the latest HP PC Hardware Diagnostics UEFI version

To download the latest HP PC Hardware Diagnostics UEFI version to a USB flash drive:

1. Go to <http://www.hp.com/go/techcenter/pcdiags>. The HP PC Diagnostics home page is displayed.
2. In the **HP PC Hardware Diagnostics UEFI** section, select **Download UEFI Diagnostics**, and then select **Run**.

Downloading HP PC Hardware Diagnostics UEFI by product name or number (select products only)



NOTE: For some products, it may be necessary to download the software to a USB flash drive by using the product name or number.

To download HP PC Hardware Diagnostics UEFI by product name or number (select products only) to a USB flash drive:

1. Go to <http://www.hp.com/support>.
2. Enter the product name or number, select your computer, and then select your operating system.
3. In the **Diagnostics** section, follow the on-screen instructions to select and download the specific UEFI Diagnostics version for your computer.

Using Remote HP PC Hardware Diagnostics UEFI settings (select products only)

Remote HP PC Hardware Diagnostics UEFI is a firmware (BIOS) feature that downloads HP PC Hardware Diagnostics UEFI to your computer. It can then execute the diagnostics on your computer, and it may upload results to a preconfigured server. For more information on Remote HP PC Hardware Diagnostics UEFI, go to <http://www.hp.com/go/techcenter/pcdiags>, and then select **Find out more**.

Downloading Remote HP PC Hardware Diagnostics UEFI

 **NOTE:** HP Remote PC Hardware Diagnostics UEFI is also available as a Softpaq that can be downloaded to a server.

Downloading the latest Remote HP PC Hardware Diagnostics UEFI version

To download the latest Remote HP PC Hardware Diagnostics UEFI version, follow these steps:

1. Go to <http://www.hp.com/go/techcenter/pcdiags>. The HP PC Diagnostics home page is displayed.
2. In the **HP PC Hardware Diagnostics UEFI** section, select **Download Remote Diagnostics**, and then select **Run**.

Downloading Remote HP PC Hardware Diagnostics UEFI by product name or number

 **NOTE:** For some products, it may be necessary to download the software by using the product name or number.

To download HP Remote PC Hardware Diagnostics UEFI by product name or number, follow these steps:

1. Go to <http://www.hp.com/support>.
2. Select **Get software and drivers**, select your type of product, enter the product name or number in the search box that is displayed, select your computer, and then select your operating system.
3. In the **Diagnostics** section, follow the on-screen instructions to select and download the **Remote UEFI** version for the product.

Customizing Remote HP PC Hardware Diagnostics UEFI settings

Using the Remote HP PC Hardware Diagnostics setting in Computer Setup (BIOS), you can perform the following customizations:

- Set a schedule for running diagnostics unattended. You can also start diagnostics immediately in interactive mode by selecting **Execute Remote HP PC Hardware Diagnostics**.
- Set the location for downloading the diagnostic tools. This feature provides access to the tools from the HP website or from a server that has been preconfigured for use. Your computer does not require the traditional local storage (such as a disk drive or USB flash drive) to run remote diagnostics.
- Set a location for storing the test results. You can also set the user name and password settings used for uploads.
- Display status information about the diagnostics run previously.

To customize Remote HP PC Hardware Diagnostics UEFI settings, follow these steps:

1. Turn on or restart the computer, and when the HP logo appears, press **f10** to enter Computer Setup.
2. Select **Advanced**, and then select **Settings**.

3. Make your customization selections.
4. Select **Main**, and then **Save Changes and Exit** to save your settings.

Your changes take effect when the computer restarts.

8 Backing up, restoring, and recovering

This chapter provides information about the following processes, which are standard procedure for most products:

- **Backing up your personal information**—You can use Windows tools to back up your personal information (see [Using Windows tools on page 73](#)).
- **Creating a restore point**—You can use Windows tools to create a restore point (see [Using Windows tools on page 73](#)).
- **Creating recovery media** (select products only)—You can use the HP Cloud Recovery Download Tool (select products only) to create recovery media (see [Using the HP Cloud Recovery Download Tool to create recovery media \(select products only\) on page 73](#)).
- **Restoring and recovery**—Windows offers several options for restoring from backup, refreshing the computer, and resetting the computer to its original state (see [Using Windows tools on page 73](#)).

 **IMPORTANT:** If you will be performing recovery procedures on a tablet, the tablet battery must be at least 70% charged before you start the recovery process.

IMPORTANT: For a tablet with a detachable keyboard, connect the tablet to the keyboard base before beginning any recovery process.

Backing up information and creating recovery media

Using Windows tools

 **IMPORTANT:** Windows is the only option that allows you to back up your personal information. Schedule regular backups to avoid information loss.

You can use Windows tools to back up personal information and create system restore points and recovery media.

 **NOTE:** If computer storage is 32 GB or less, Microsoft System Restore is disabled by default.

For more information and steps, see the Get Help app.

1. Select the **Start** button, and then select the **Get Help** app.
2. Enter the task you want to perform.

 **NOTE:** You must be connected to the Internet to access the Get Help app.

Using the HP Cloud Recovery Download Tool to create recovery media (select products only)

You can use the HP Cloud Recovery Download Tool to create HP Recovery media on a bootable USB flash drive, as follows:

1. Go to <http://www.hp.com/support>.
2. Select **Software and Drivers**, and then follow the on-screen instructions.



NOTE: If you cannot create recovery media yourself, contact support to obtain recovery discs. Go to <http://www.hp.com/support>, select your country or region, and then follow the on-screen instructions.

Restoring and recovery

Restoring, resetting, and refreshing using Windows tools

Windows offers several options for restoring, resetting, and refreshing the computer. For details, see [Using Windows tools on page 73](#).

Recovering using HP Recovery media

HP Recovery media is used to recover the original operating system and software programs that were installed at the factory. On select products, it can be created on a bootable USB flash drive using the HP Cloud Recovery Download Tool. For details, see [Using the HP Cloud Recovery Download Tool to create recovery media \(select products only\) on page 73](#).



NOTE: If you cannot create recovery media yourself, contact support to obtain recovery discs. Go to <http://www.hp.com/support>, select your country or region, and then follow the on-screen instructions.

To recover your system:

- ▲ Insert the HP Recovery media, and then restart the computer.

Changing the computer boot order

If your computer does not restart using the HP Recovery media, you can change the computer boot order. This is the order of devices listed in BIOS where the computer looks for startup information. You can change the selection to an optical drive or a USB flash drive, depending on the location of your HP Recovery media.

To change the boot order:



IMPORTANT: For a tablet with a detachable keyboard, connect the tablet to the keyboard base before beginning these steps.

1. Insert the HP Recovery media.
2. Access the system **Startup** menu.

For computers or tablets with keyboards attached:

- ▲ Turn on or restart the computer or tablet, quickly press **esc**, and then press **f9** for boot options.

For tablets without keyboards:

- ▲ Turn on or restart the tablet, quickly hold down the volume up button, and then select **f9**.

– or –

Turn on or restart the tablet, quickly hold down the volume down button, and then select **f9**.

3. Select the optical drive or USB flash drive from which you want to boot, and then follow the on-screen instructions.

9 Specifications

Computer specifications

	Metric	U.S.
Dimensions		
Length	234.0 mm	9.21 in
Width	335.0 mm	13.19 in
Height	19.9 mm	0.78 in
Weight		
With solid-state drive or eMMC	1509.4 g	3.3 lbs
With hard drive	1545.7 g	3.4 lbs
With solid-state drive and hard drive	1554.0 g	3.43 lbs
Input power		
Operating voltage	19.0 V dc @ 4.74 A – 90 W or 18.5 V dc @ 3.5 A - 65 W or 45 W	
Operating current	4.74 A or 3.5 A	
Temperature		
Operating (not writing to optical disc)	0°C to 35°C	32°F to 95°F
Operating (writing to optical disc)	5°C to 35°C	41°F to 95°F
Nonoperating	-20°C to 60°C	-4°F to 140°F
Relative humidity		
Operating	10% to 90%	
Nonoperating	5% to 95%	
NOTE: Applicable product safety standards specify thermal limits for plastic surfaces. The computer operates well within this range of temperatures.		

35.6-cm (14.0-in) display specifications

	Metric	U.S.
Active diagonal size	35.6-cm	14.0-in
Resolution	FHD: 1920×1080 HD: 1366×768	
Surface treatment	Anti-glare BrightView	
Brightness	220 nits	
Viewing angle	SVA (HD panels) UWVA (FHD panels)	
Backlight	LED	
Aspect ratio	16:9	
Display panel interface	eDP	

M.2 SATA solid-state drive specifications

	128-GB*	256-GB*	512-GB*
Height	1.35 mm	1.35 mm	1.35 mm
Weight	< 10 g	< 10 g	< 10 g
Form factor	M.2 2280-D2-B-M	M.2 2280-D2-B-M	M.2 2280-D2-B-M
Transfer rate	up to 540 MB/sec	up to 540 MB/sec	up to 540 MB/sec
Interface type	SATA-3	SATA-3	SATA-3
Ready time, maximum (to not busy)	1.0 ms	< 1.0 ms	< 1.0 ms
Access times, logical	0.1 ms	0.1 ms	0.1 ms
Total logical sectors	234,441,648	468,883,296	937,766,592
Operating temperature	0°C to 70°C (32°F to 158°F)		
*1 GB = 1 billion bytes when referring to hard drive storage capacity. Actual accessible capacity is less. Actual drive specifications may differ slightly.			
NOTE: Certain restrictions and exclusions apply. Contact technical support for details.			

M.2 PCIe solid-state drive specifications

	128-GB*	256-GB*	512-GB*
Dimensions			
Height	1 mm	1 mm	1 mm
Length	50.8 mm	50.8 mm	50.8 mm
Width	28.9 mm	28.9 mm	28.9 mm
Weight	< 10 g	< 10 g	< 10 g
Interface type	ATA-7	ATA-7	ATA-7
Transfer rate			
Sequential Read	Up to 520 MB/s	Up to 2150 MB/s	Up to 2150 MB/s
Random Read	Up to 60,000 IOPs	Up to 300,000 IOPs	Up to 300,000 IOPs
Sequential Write	Up to 160 MB/s	Up to 1260 MB/s	Up to 1550 MB/s
Random Write	Up to 34,000 IOPs	Up to 100,000 IOPs	Up to 100,000 IOPs
Ready time, Maximum (to not busy)	1.0 s	1.0 s	1.0 s
Access times			
Logical	0.1 ms	0.1 ms	0.1 ms
Total logical sectors	250,069,680	500,118,192	1,000,215,216
Operating temperature			
Operating	0° to 70°C (32°F to 158°F)	0° to 70°C (32°F to 158°F)	0° to 70°C (32°F to 158°F)
Non-operating	-40° to 95°C (-40°F to 203°F)	-40° to 80°C (-40°F to 176°F)	-40° to 85°C (-40°F to 185°F)
*1 GB = 1 billion bytes when referring to hard drive storage capacity. Actual accessible capacity is less.			
NOTE: Certain restrictions and exclusions apply. Contact technical support for details.			

Hard drive specifications

	1-TB*	500-GB*
Dimensions		
Height	7.0 mm or 9.5 mm	7.0 mm
Length	100.4 mm	100.6 mm
Width	69.9 mm	70.1 mm
Weight	107.0 g	92.0 g
Interface type		
	SATA	SATA
Transfer rate		
Synchronous (maximum)	300 MB/sec	300 MB/sec
Security	ATA security	ATA security
Seek times (typical read, including setting)		
Single track	2.0 ms	3 ms
Average (read/write)	12 ms	13 ms
Maximum	22 ms	24 ms
Logical blocks		
	1,953,525,168	1,048,576,000
Disk rotational speed		
	5400 rpm	5400 rpm
Operating temperature		
*1 GB = 1 billion bytes when referring to hard drive storage capacity. Actual accessible capacity is less.		
NOTE: Certain restrictions and exclusions apply. Contact technical support for details.		

10 Power cord set requirements

The wide-range input feature of the computer permits it to operate from any line voltage from 100 to 120 volts AC, or from 220 to 240 volts AC.

The 3-conductor power cord set included with the computer meets the requirements for use in the country or region where the equipment is purchased.

Power cord sets for use in other countries and regions must meet the requirements of the country or region where the computer is used.

Requirements for all countries

The following requirements are applicable to all countries and regions:

- The length of the power cord set must be at least **1.0 m** (3.3 ft) and no more than **2.0 m** (6.5 ft).
- All power cord sets must be approved by an acceptable accredited agency responsible for evaluation in the country or region where the power cord set will be used.
- The power cord sets must have a minimum current capacity of 10 amps and a nominal voltage rating of 125 or 250 V AC, as required by the power system of each country or region.
- The appliance coupler must meet the mechanical configuration of an EN 60 320/IEC 320 Standard Sheet C13 connector for mating with the appliance inlet on the back of the computer.

Requirements for specific countries and regions

Country/region	Accredited agency	Applicable note number
Australia	EANSW	1
Austria	OVE	1
Belgium	CEBC	1
Canada	CSA	2
Denmark	DEMKO	1
Finland	FIMKO	1
France	UTE	1
Germany	VDE	1
Italy	IMQ	1
Japan	METI	3
The Netherlands	KEMA	1
Norway	NEMKO	1
The People's Republic of China	COC	5
South Korea	EK	4

Country/region	Accredited agency	Applicable note number
Sweden	SEMKO	1
Switzerland	SEV	1
Taiwan	BSMI	4
The United Kingdom	BSI	1
The United States	UL	2

1. The flexible cord must be Type H05VV-F, 3-conductor, 1.0-mm² conductor size. Power cord set fittings (appliance coupler and wall plug) must bear the certification mark of the agency responsible for evaluation in the country or region where it will be used.
2. The flexible cord must be Type SPT-3 or equivalent, No. 18 AWG, 3-conductor. The wall plug must be a two-pole grounding type with a NEMA 5-15P (15 A, 125 V) or NEMA 6-15P (15 A, 250 V) configuration.
3. The appliance coupler, flexible cord, and wall plug must bear a “T” mark and registration number in accordance with the Japanese Dentori Law. The flexible cord must be Type VCT or VCTF, 3-conductor, 1.00-mm² conductor size. The wall plug must be a two-pole grounding type with a Japanese Industrial Standard C8303 (7 A, 125 V) configuration.
4. The flexible cord must be Type RVV, 3-conductor, 0.75-mm² conductor size. Power cord set fittings (appliance coupler and wall plug) must bear the certification mark of the agency responsible for evaluation in the country or region where it will be used.
5. The flexible cord must be Type VCTF, 3-conductor, 0.75-mm² conductor size. Power cord set fittings (appliance coupler and wall plug) must bear the certification mark of the agency responsible for evaluation in the country or region where it will be used.

11 Recycling

When a non-rechargeable or rechargeable battery has reached the end of its useful life, do not dispose of the battery in general household waste. Follow the local laws and regulations in your area for battery disposal.

HP encourages customers to recycle used electronic hardware, HP original print cartridges, and rechargeable batteries. For more information about recycling programs, see the HP Web site at <http://www.hp.com/recycle>.

Index

- A**
 - AC adapter and battery light, identifying 6
 - AC adapter, spare part numbers 23
 - action keys
 - airplane mode 13
 - help 13
 - identifying 12, 13
 - keyboard backlight 13
 - mute 13
 - next track 13
 - pause 13
 - play 13
 - screen brightness 13
 - speaker volume 13
 - switch screen image 13
 - using 13
 - airplane mode key 13
 - antenna
 - removal 62
 - audio
 - adjusting volume 13
 - audio-out (headphone)/audio-in (microphone) combo jack, identifying 6
- B**
 - back cover
 - spare part number 21
 - backup, creating 73
 - backups 73
 - battery
 - removal 32
 - spare part number 18, 32
 - BIOS
 - determining version 66
 - downloading an update 67
 - starting the Setup Utility 66
 - updating 66
 - Bluetooth label 15
 - boot order, changing 74
 - bottom components 14
 - bottom cover
 - removal 30
 - spare part number 18, 30
- C**
 - buttons
 - left TouchPad 9
 - power 11
 - right TouchPad 9
 - camera
 - identifying 8
 - product description 2
 - camera light, identifying 8
 - camera module
 - removal 57
 - spare part number 21
 - spare part numbers 58
 - caps lock light, identifying 10
 - chipset, product description 1
 - components
 - bottom 14
 - display 8
 - keyboard area 9
 - left side 7
 - right side 6
 - computer major components 16
 - computer specifications 75
 - connector, power 6
- D**
 - Display assembly
 - spare part numbers 17
 - display assembly
 - removal 56
 - subcomponents 20
 - display assembly components
 - removal 56
 - spare part numbers 56
 - display bezel
 - removal 57
 - spare part numbers 20, 57
 - display cable, spare part number 21
 - display components 8
 - display panel
 - product description 1
 - removal 58
- E**
 - display panel cable
 - removal 62
 - spare part numbers 62
 - display specifications 76
 - drive light, identifying 7
- E**
 - esc key, identifying 12
 - ethernet
 - product description 3
- F**
 - fan
 - removal 44
 - spare part number 18, 44
 - fan insert
 - spare part number 18
 - fn key, identifying 12
- G**
 - Get Help in Windows 10 action key 13
- H**
 - hard drive
 - product description 2
 - removal 36
 - spare part number 18, 22
 - spare part numbers 36
 - specifications 78
 - hard drive cable
 - spare part number 22
 - hard drive cover
 - spare part number 22
 - HDMI port
 - identifying 6
 - heat sink
 - spare part numbers 18
 - heat sink assembly
 - removal 45
 - spare part numbers 45
 - hinge
 - removal 61
 - spare part number 62

- hinge cover
 - spare part number 20
- Hinge Kit
 - spare part number 21
- HP PC Hardware Diagnostics UEFI
 - downloading 70
 - starting 70
 - using 69
- HP PC Hardware Diagnostics Windows
 - downloading 68
 - installing 69
 - using 68
- HP Recovery media
 - recovery 74
- I**
- internal microphones, identifying 8
- J**
- jacks
 - audio-out (headphone)/audio-in (microphone) 6
 - network 6
 - RJ-45 (network) 6
- K**
- keyboard
 - product description 3
 - removal 65
 - spare part number 65
 - spare part numbers 17
- keyboard backlight action key 13
- keys
 - action 12
 - airplane mode 13
 - esc 12
 - fn 12
 - Windows 12
- L**
- labels
 - Bluetooth 15
 - regulatory 15
 - serial number 15
 - service 15
 - wireless certification 15
 - WLAN 15
- left side components 7
- lights
 - AC adapter and battery 6
 - camera 8
 - caps lock 10
 - drive 7
 - mute 10
 - power 7
 - RJ-45 (network) status 6
- M**
- M.2 solid-state drive
 - specifications 77
- memory
 - product description 2
 - removal 34
 - spare part number 18
 - spare part numbers 34
- MicroSD memory card reader, identifying 7
- model name 1
- mute light, identifying 10
- mute volume action key 13
- N**
- network jack, identifying 6
- next track action key 13
- O**
- operating system, product description 4
- P**
- panel
 - spare part numbers 20
- pause action key 13
- play action key 13
- pointing device, product description 3
- ports
 - HDMI 6
 - product description 3
 - USB 7
 - USB SuperSpeed 6
- power button, identifying 11
- power connector
 - identifying 6
- power connector cable
 - removal 54
 - spare part numbers 54
- power cord
 - set requirements 79
- power lights, identifying 7
- power requirements, product description 3
- processor 1
- product description
 - camera 2
 - chipset 1
 - display panel 1
 - ethernet 3
 - external media cards 3
 - hard drive 2
 - keyboard 3
 - memory 2
 - operating system 4
 - pointing device 3
 - ports 3
 - power requirements 3
 - processor 1
 - product name 1
 - security 4
 - serviceability 5
 - wireless networking 3
- product name 1
- product name and number, computer 15
- R**
- recovery 73
 - discs 74
 - HP Recovery partition 74
 - media 74
 - USB flash drive 74
- recovery media
 - creating using HP Cloud Recovery Download Tool 73
 - creating using Windows tools 73
- regulatory information
 - regulatory label 15
 - wireless certification labels 15
- Remote HP PC Hardware Diagnostics UEFI settings
 - customizing 71
 - using 71
- removal/replacement
 - procedures 29
- restoring 73
- right side components 6
- RJ-45 (network) jack, identifying 6
- RJ-45 (network) status lights, identifying 6
- S**
- screen brightness action keys 13

- Screw Kit, spare part numbers 23
- security cable slot, identifying 7
- security, product description 4
- serial number, computer 15
- service labels, locating 15
- serviceability, product description 5
- slots
 - memory card reader 7
 - security cable 7
- solid-state drive
 - removal 38
 - spare part number 18, 22
 - spare part numbers 38
 - specifications 76
- speaker volume action keys 13
- speakers
 - identifying 11
 - removal 42
 - spare part number 18
 - spare part numbers 42
- special keys, using 12
- specifications
 - computer 75
 - display 76
 - hard drive 78
 - M.2 solid-state drive 77
 - solid-state drive 76
- switch screen image action key 13
- system board
 - removal 50
 - spare part number 17
 - spare part numbers 50
- system board hook
 - removal 41
 - spare part number 18, 41
- system restore point, creating 73

T

- top cover
 - removal 65
 - spare part number 65
- top cover/keyboard
 - spare part numbers 17
- TouchPad button board
 - removal 43
 - spare part number 17
 - spare part numbers 43
- TouchPad buttons
 - identifying 9

- TouchPad module
 - removal 49
 - spare part number 17, 49
- TouchPad zone, identifying 9
- traveling with the computer 15

U

- USB board
 - removal 55
 - spare part number 55
- USB port, identifying 7
- USB SuperSpeed port, identifying 6
- USB/card reader/power button board
 - spare part number 18

V

- vents, identifying 11, 14
- volume
 - adjusting 13
 - mute 13

W

- Windows
 - backup 73
 - recovery media 73
 - system restore point 73
- Windows key, identifying 12
- Windows tools, using 73
- wireless antenna
 - removal 62
- wireless certification label 15
- wireless networking
 - product description 3
- WLAN
 - removal 39
 - spare part numbers 39
- WLAN antenna
 - removal 62
- WLAN antennas, identifying 8
- WLAN cable
 - spare part number 21
- WLAN device 15
- WLAN label 15
- WLAN module
 - spare part number 18