



Maintenance and Service Guide

HP Chromebook x360 14b
IMPORTANT! This document is intended for
HP authorized service providers only.

© Copyright 2019 HP Development Company, L.P.

Bluetooth is a trademark owned by its proprietor and used by HP Inc. under license. Chromebook is a trademark of Google LLC. Intel, Pentium, and Celeron are trademarks of Intel Corporation or its subsidiaries in the U.S. and/or other countries. Microsoft and Windows are either registered trademarks or trademarks of Microsoft Corporation in the United States and/or other countries. microSD is a trademark or registered trademark of SD-3C in the United States, other countries or both. DisplayPort is a trademark owned by the Video Electronics Standards Association (VESA®) in the United States and other countries.

The information contained herein is subject to change without notice. The only warranties for HP products and services are set forth in the express warranty statements accompanying such products and services. Nothing herein should be construed as constituting an additional warranty. HP shall not be liable for technical or editorial errors or omissions contained herein.

First Edition: September 2019

Document Part Number: L73799-001

Product notice

This guide describes features that are common to most models. Some features may not be available on the computer.

Not all features are available in all editions or versions of Windows. Systems may require upgraded and/or separately purchased hardware, drivers, software or BIOS update to take full advantage of Windows functionality. Windows 10 is automatically updated, which is always enabled. ISP fees may apply and additional requirements may apply over time for updates. Go to <http://www.microsoft.com> for details.

To access the latest user guides, go to <http://www.hp.com/support>, and follow the instructions to find your product. Then select **User Guides**.

Software terms

By installing, copying, downloading, or otherwise using any software product preinstalled on this computer, you agree to be bound by the terms of the HP End User License Agreement (EULA). If you do not accept these license terms, your sole remedy is to return the entire unused product (hardware and software) within 14 days for a full refund subject to the refund policy of the seller.

For any further information or to request a full refund of the price of the computer, please contact the seller.

Safety warning notice

 **WARNING!** To reduce the possibility of heat-related injuries or of overheating the device, do not place the device directly on your lap or obstruct the device air vents. Use the device only on a hard, flat surface. Do not allow another hard surface, such as an adjoining optional printer, or a soft surface, such as pillows or rugs or clothing, to block airflow. Also, do not allow the AC adapter to contact the skin or a soft surface, such as pillows or rugs or clothing, during operation. The device and the AC adapter comply with the user-accessible surface temperature limits.

Table of contents

1 Product description	1
2 External component identification	3
Right side	3
Left side	4
Display	6
Keyboard area	7
Touchpad	7
Speakers	8
Special keys	9
Labels	9
3 Illustrated parts catalog	11
Computer major components	11
Display components	15
Miscellaneous parts	16
4 Removal and replacement procedures preliminary requirements	17
Tools required	17
Service considerations	17
Plastic parts	17
Cables and connectors	17
Drive handling	18
Electrostatic discharge damage	18
Packaging and transporting guidelines	19
Workstation guidelines	20
Equipment guidelines	20
5 Removal and replacement procedures	22
Component replacement procedures	22
Bottom cover	22
Battery	24
WLAN module	26
USB/audio board cable	28
USB/audio board	29
System board	30

Power cable	34
Speakers	35
Display assembly	36
Touchpad cable	47
Touchpad	48
6 Specifications	50
Computer specifications	50
7 Backing up, resetting, and recovering	52
Backing up	52
Resetting	52
Recovering	53
Installing the Chromebook Recovery Utility	53
Creating recovery media	53
Recovering the Chrome operating system	54
Setting up the computer after a reset or recovery	54
Erase and format the recovery media	54
8 Power cord set requirements	55
Requirements for all countries	55
Requirements for specific countries and regions	56
9 Recycling	58
Index	59

1 Product description

Table 1-1 Product components and descriptions

Category	Description
Product Name	HP Chromebook™ x360 14b (model number: 14b-ca0xxx; CTO model number 14bt-ca000)
Processors	Intel® Pentium® N5000 1.1 GHz (turbo up to 2.7 GHz) processor (2400 MHz FSB, 4-MB L2 cache, quad core, 6 W) Intel Celeron® N4000 1.1 GHz (turbo up to 2.6 GHz) processor (2400 MHz FSB, 4-MB L2 cache, dual core, 6 W)
Chipset	Intel integrated soldered-on-circuit (SoC)
Graphics	Graphics Card: Intel UHD Graphics 605 and Intel UHD Graphics 600
Panel	<ul style="list-style-type: none">• 14.0-in, full high-definition (FHD) (1920×1080), antiglare, liquid crystal display (LCD), white light-emitting diode (WLED), UWVA, 45, 250, embedded DisplayPort (eDP), slim touchscreen+USI support display panel with narrow bezel• 14.0-in, FHD (1920×1080), antiglare, LCD, WLED, UWVA, 45, 250, eDP, slim touchscreen display panel with narrow bezel• 14.0-in, high-definition (HD) (1366×768), antiglare, LCD, WLED, SVA, 45, 220, eDP 1.2, slim touchscreen +USI support display panel with narrow bezel• 14.0-in, HD (1366×768), antiglare, LCD, WLED, SVA, 45, 220, eDP 1.2, slim touchscreen display panel with narrow bezel
Memory	Support for LPDDR4 memory Support for up to 8-GB of system memory in the following configurations: 8-GB 2400 LPDDR4 1.1 V IC 512-MB×32 ×4 pieces 4-GB 2400 LPDDR4 1.1 V IC 256-MB×32 ×4 pieces
Storage	Embedded MultiMediaCard (eMMC): <ul style="list-style-type: none">• eMMC 128 GB MMC v5.0• eMMC 64 GB MMC v5.0• eMMC 32 GB MO-276 MMC v5.0
Audio and video	Audio: Integrated dual B and O speakers with HD Audio Camera: Integrated one-piece fixed HD 720p-YSEB camera Microphones: Dual-array microphone
Wireless	Wireless local area network (WLAN) options: Intel 9560 ac 2×2 MU-MIMO + Bluetooth® 5.0 M.2 non-vPro CNVi WW with 2 antennas
External media cards	HP MultiFormat microSD® media card reader
Ports	<ul style="list-style-type: none">• Audio-out (headphone)/audio-in (microphone) combo jack• USB 3.1 Gen. 1 Type-A port• USB 3.1 Gen. 1 Type-C port (2)
Keyboard	<ul style="list-style-type: none">• Island-style keyboard with touchpad with backlight in mineral silver finish• Island-style keyboard with touchpad without backlight in mineral silver finish

Table 1-1 Product components and descriptions (continued)

Category	Description
Keyboard <i>(continued)</i>	<ul style="list-style-type: none">• Island-style keyboard with touchpad with backlight in natural silver finish• Island-style keyboard with touchpad without backlight in natural silver finish
Security	H1 Secure Microcontroller Nano security lock
Power requirements	Support for a 2-cell, 47 Wh, 6.15-Ah, Li-ion battery Support for a 45 W AC adapter (non-PFC, USB Type-C, 1.8 m, 3 pin) Support for a conventional 1.00-m power cord with a C5 connector
Operating system	Chrome 64

2 External component identification

The computer features top-rated components. This chapter provides details about the computer components, where they are located, and how they work.

Right side

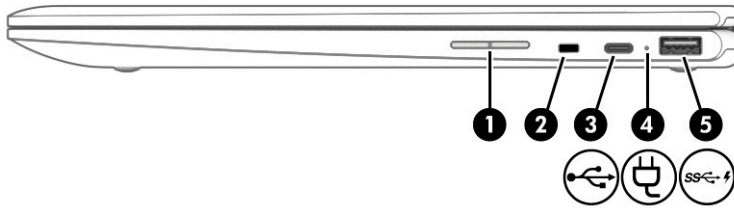

Table 2-1 Right-side components and their descriptions







Component	Description
(1)  Volume button	Controls speaker volume on the computer.
(2)  Security cable slot	Attaches an optional security cable to the computer. NOTE: The security cable is designed to act as a deterrent, but it may not prevent the computer from being mishandled or stolen.
(3)  USB Type-C power connector and port	Connects an AC adapter that has a USB Type-C connector, supplying power to the computer and, if needed, charging the computer battery. – and – Connects a USB device that has a Type-C connector, such as a cell phone, camera, activity tracker, or smartwatch, and provides data transfer. – and – Connects a display device that has a USB Type-C connector, providing DisplayPort™ output. NOTE: Cables and/or adapters (purchased separately) may be required.
(4)  AC adapter and battery light	<ul style="list-style-type: none">• White: The AC adapter is connected and the battery is fully charged.• Blinking white: The AC adapter is disconnected and the battery has reached a low battery level.• Amber: The AC adapter is connected and the battery is charging.

Table 2-1 Right-side components and their descriptions (continued)

Component	Description
(4) 	AC adapter and battery light (<i>continued</i>) <ul style="list-style-type: none"> • Off: The battery is not charging.
(5) 	Connects a USB device, provides high-speed data transfer, and even when the computer is in Sleep mode, charges most products such as a cell phone, camera, activity tracker, or smartwatch.

Left side

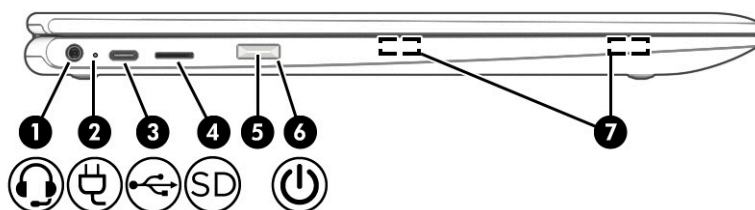

Table 2-2 Left-side components and their descriptions







Component	Description
(1) 	Audio-out (headphone)/Audio-in (microphone) combo jack <p>Connects optional powered stereo speakers, headphones, earbuds, a headset, or a television audio cable. Also connects an optional headset microphone. This jack does not support optional standalone microphones.</p> <p>WARNING! To reduce the risk of personal injury, adjust the volume before putting on headphones, earbuds, or a headset. For additional safety information, see the <i>Regulatory, Safety, and Environmental Notices</i>.</p> <p>To access this guide:</p> <ul style="list-style-type: none"> ▲ Select the Start button, select HP Help and Support, and then select HP Documentation. <p>NOTE: When a device is connected to the jack, the computer speakers are disabled.</p>
(2) 	AC adapter and battery light <ul style="list-style-type: none"> • White: The AC adapter is connected and the battery is fully charged. • Blinking white: The AC adapter is disconnected and the battery has reached a low battery level. • Amber: The AC adapter is connected and the battery is charging. • Off: The battery is not charging.
(3) 	USB Type-C power connector and port <p>Connects an AC adapter that has a USB Type-C connector, supplying power to the computer and, if needed, charging the computer battery.</p> <p>– and –</p> <p>Connects a USB device that has a Type-C connector, such as a cell phone, camera, activity tracker, or smartwatch, and provides data transfer.</p>

Table 2-2 Left-side components and their descriptions (continued)

Component	Description
(3)  USB Type-C power connector and port (continued)	– and – Connects a display device that has a USB Type-C connector, providing DisplayPort™ output. NOTE: Cables and/or adapters (purchased separately) may be required.
(4)  microSD™ memory card reader	Reads optional memory cards that enable you to store, manage, share, or access information. To insert a card: <ol style="list-style-type: none"> 1. Hold the card label-side up, with connectors facing the computer. 2. Insert the card into the memory card reader, and then press in on the card until it is firmly seated. To remove a card: <ul style="list-style-type: none"> ▲ Press in on the card, and then remove it from the memory card reader.
(5) Power button	<ul style="list-style-type: none"> ● When the computer is off, press the button to turn on the computer. ● When the computer is on, press the button briefly to initiate Sleep. ● When the computer is in the Sleep state, press the button briefly to exit Sleep (select products only). IMPORTANT: Pressing and holding down the power button results in the loss of unsaved information. If the computer has stopped responding and shutdown procedures are ineffective, press and hold the power button down for at least 5 seconds to turn off the computer.
(6)  Power light	On: The computer is on. Off: The computer is off or in the Sleep state.
(7) Magnetic stylus docking	Connects an optional stylus.

Display

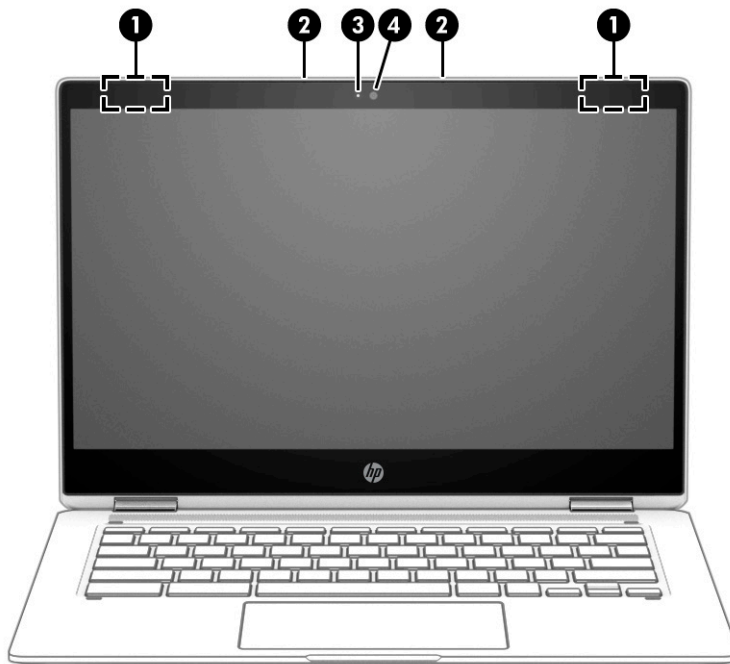

Table 2-3 Display components and their descriptions

Component	Description
(1) WLAN antennas*	Send and receive wireless signals to communicate with WLANs.
(2) Internal microphones (2)	Record sound.
(3) Camera light	On: The camera is in use.
(4) Camera	Allows you to video chat, record video, and record still images. NOTE: Camera functions vary depending on the camera hardware and software installed on your product.

*The antennas are not visible from the outside of the computer. For optimal transmission, keep the areas immediately around the antennas free from obstructions.

For wireless regulatory notices, see the section of the *Regulatory, Safety, and Environmental Notices* that applies to your country or region.

Keyboard area

Touchpad

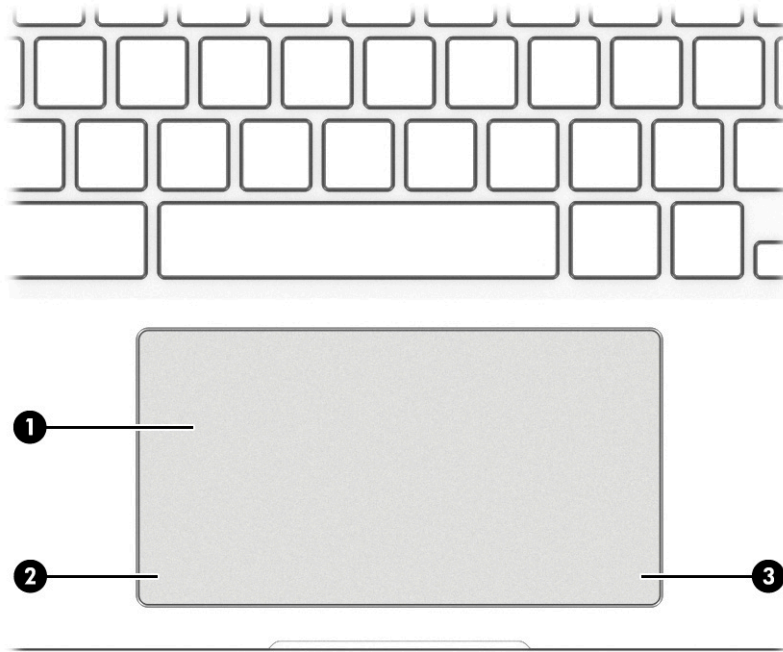

Table 2-4 Keyboard components and descriptions

Component	Description
(1) Touchpad zone	Reads finger gestures to move the pointer or activate items on the screen.
(2) Left touchpad button	Functions like the left button on an external mouse.
(3) Right touchpad button	Functions like the right button on an external mouse.

Speakers

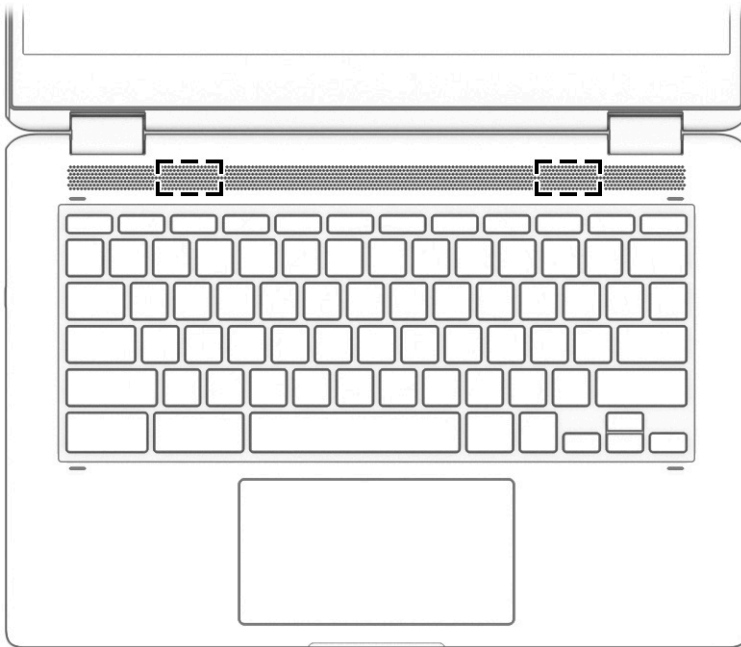

Table 2-5 Speaker components and their descriptions

Component	Description
Speakers	Produce sound.

Special keys

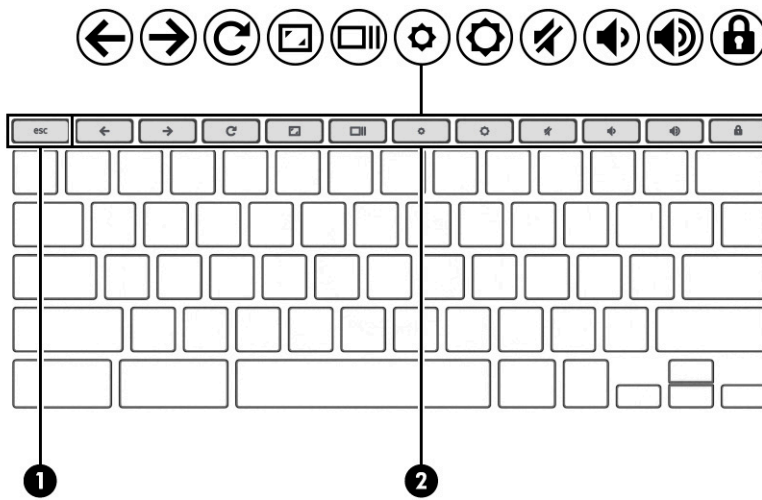

Table 2-6 Special key components and descriptions

Component	Description
(1) <code>esc</code> key	Displays system information when pressed in combination with the <code>fn</code> key.
(2) Action keys	Execute frequently used system functions.

Labels

The labels affixed to the computer provide information that may be needed when troubleshooting system problems or traveling internationally with the computer. Labels may be in paper form or imprinted on the product.

IMPORTANT: Check the following locations for the labels described in this section: the bottom of the computer, inside the battery bay, under the service door, on the back of the display, or on the bottom of a tablet kickstand.

- Service label—Provides important information to identify the computer. When contacting support, you may be asked for the serial number, the product number, or the model number. Locate this information before contacting support.

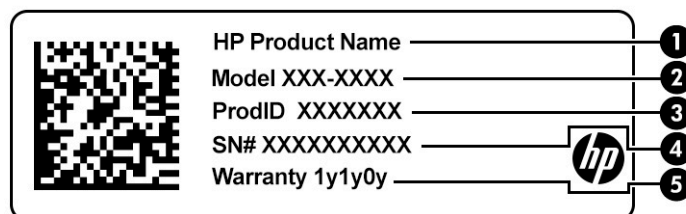

Table 2-7 Service label components

Component	
(1)	HP product name
(2)	Model number
(3)	Product ID
(4)	Serial number
(5)	Warranty period

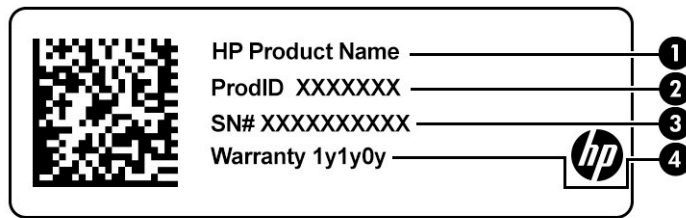



Table 2-8 Service label components

Component	
(1)	HP product name
(2)	Product ID
(3)	Serial number
(4)	Warranty period

- Regulatory label(s)—Provide(s) regulatory information about the computer.
- Wireless certification label(s)—Provide(s) information about optional wireless devices and the approval markings for the countries or regions in which the devices have been approved for use.

3 Illustrated parts catalog

Computer major components

 **NOTE:** HP continually improves and changes product parts. For complete and current information on supported parts for the computer, go to <http://partsurfer.hp.com>, select the country or region, and then follow the on-screen instructions.

 **NOTE:** Details about the computer, including model number, serial number, product identification, and length of warranty, are on the service tag at the bottom of the computer. See [Labels on page 9](#) for details.

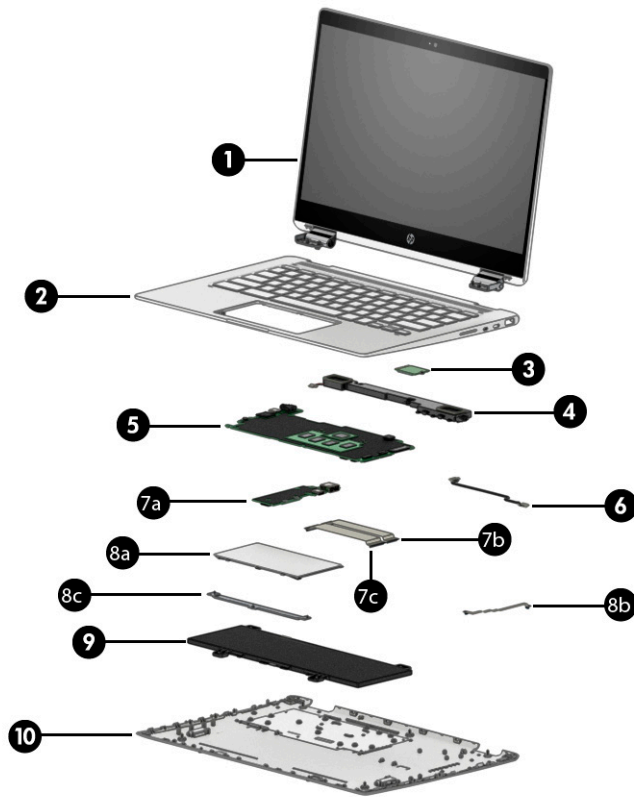

Table 3-1 Computer component descriptions and spare part information

Item	Component	Spare part number
(1)	Display assembly: The display assembly is spared at the subcomponent level only. For more display assembly spare part information, see Display components on page 15 .	
(2)	Keyboard/top cover with backlight in mineral silver finish (includes backlight cable and keyboard cable):	
	For use in Belgium	L73306-A41
	For use in Canada	L73306-DB1
	For use in Denmark, Finland, and Norway	L73306-DH1
	For use in France	L73306-051

Table 3-1 Computer component descriptions and spare part information (continued)

Item	Component	Spare part number
	For use in Germany	L73306-041
	For use in Japan	L73306-291
	For use in the Netherlands	L73306-B31
	For use in Russia	L73306-251
	For use in Spain	L73306-071
	For use in the United Kingdom	L73306-031
	For use in the United States	L73306-001
	Keyboard/top cover with backlight in mineral silver finish (includes backlight cable and keyboard cable):	
	For use in Belgium	L73308-A41
	For use in Canada	L73308-DB1
	For use in Denmark, Finland, and Norway	L73308-DH1
	For use in France	L73308-051
	For use in Germany	L73308-041
	For use in Japan	L73308-291
	For use in the Netherlands	L73308-B31
	For use in Russia	L73308-251
	For use in Spain	L73308-071
	For use in the United Kingdom	L73308-031
	For use in the United States	L73308-001
	Keyboard/top cover without backlight in mineral silver finish (includes keyboard cable):	
	For use in Belgium	L73305-A41
	For use in Canada	L73305-DB1
	For use in Denmark, Finland, and Norway	L73305-DH1
	For use in France	L73305-FM1
	For use in Germany	L73305-041
	For use in Japan	L73305-291
	For use in the Netherlands	L73305-331
	For use in Russia	L73305-251
	For use in Spain	L73305-071
	For use in the United Kingdom	L73305-031
	For use in the United States	L73305-001
	Keyboard/top cover without backlight in natural silver finish (includes keyboard cable):	
	For use in Belgium	L73307-A41

Table 3-1 Computer component descriptions and spare part information (continued)

Item	Component	Spare part number
	For use in Canada	L73307-DB1
	For use in Denmark, Finland, and Norway	L73307-DH1
	For use in France	L73307-FM1
	For use in Germany	L73307-041
	For use in Japan	L73307-291
	For use in the Netherlands	L73307-331
	For use in Russia	L73307-251
	For use in Spain	L73307-071
	For use in the United Kingdom	L73307-031
	For use in the United States	L73307-001
(3)	Intel 9560 ac 2x2 MU-MIMO + Bluetooth 5.0 M.2 non-vPro MIPI+BRI WW with WLAN module two antenna	L41693-005
(4)	Speakers (includes left and right speakers, cables, and 3 rubber isolators)	L73318-001
(5)	System board (includes processor and replacement thermal material):	
	For use only on computer models equipped with a backlit keyboard/top cover:	
	Equipped with an Intel Pentium N5000 1.1 GHz (turbo up to 2.7 GHz) processor (2400-MHz FSB, 4-MB L2 cache, quad core, 6 W), a graphics subsystem with UMA memory, 8-GB of system memory, 128-GB of eMMC storage, and a non-Windows 10 operating system	L73300-001
	Equipped with an Intel Pentium N5000 1.1 GHz (turbo up to 2.7 GHz) processor (2400-MHz FSB, 4-MB L2 cache, quad core, 6 W), a graphics subsystem with UMA memory, 8-GB of system memory, 64-GB of eMMC storage, and a non-Windows 10 operating system	L70811-001
	Equipped with an Intel Pentium N5000 1.1 GHz (turbo up to 2.7 GHz) processor (2400-MHz FSB, 4-MB L2 cache, quad core, 6 W), a graphics subsystem with UMA memory, 4-GB of system memory, 64-GB of eMMC storage, and a non-Windows 10 operating system	L70810-001
	Equipped with an Intel Celeron N4000 1.1 GHz (turbo up to 2.6 GHz) processor (2400-MHz FSB, 4-MB L2 cache, dual core, 6 W), a graphics subsystem with UMA memory, 4-GB of system memory, 64-GB of eMMC storage, and a non-Windows 10 operating system	L70809-001
	Equipped with an Intel Celeron N4000 1.1 GHz (turbo up to 2.6 GHz) processor (2400-MHz FSB, 4-MB L2 cache, dual core, 6 W), a graphics subsystem with UMA memory, 4-GB of system memory, 32-GB of eMMC storage, and a non-Windows 10 operating system	L70808-001
	For use only on computer models equipped with a non-backlit keyboard/top cover:	
	Equipped with an Intel Pentium N5000 1.1 GHz (turbo up to 2.7 GHz) processor (2400-MHz FSB, 4-MB L2 cache, quad core, 6 W), a graphics subsystem with UMA memory, 8-GB of system memory, 128-GB of eMMC storage, and a non-Windows 10 operating system	L85681-001
	Equipped with an Intel Pentium N5000 1.1 GHz (turbo up to 2.7 GHz) processor (2400-MHz FSB, 4-MB L2 cache, quad core, 6 W), a graphics subsystem with UMA memory, 8-GB of system memory, 64-GB of eMMC storage, and a non-Windows 10 operating system	L85676-001
	Equipped with an Intel Pentium N5000 1.1 GHz (turbo up to 2.7 GHz) processor (2400-MHz FSB, 4-MB L2 cache, quad core, 6 W), a graphics subsystem with UMA memory, 4-GB of system memory, 64-GB of eMMC storage, and a non-Windows 10 operating system	L85675-001

Table 3-1 Computer component descriptions and spare part information (continued)

Item	Component	Spare part number
	Equipped with an Intel Celeron N4000 1.1 GHz (turbo up to 2.6 GHz) processor (2400-MHz FSB, 4-MB L2 cache, dual core, 6 W), a graphics subsystem with UMA memory, 4-GB of system memory, 64-GB of eMMC storage, and a non-Windows 10 operating system	L85674-001
	Equipped with an Intel Celeron N4000 1.1 GHz (turbo up to 2.6 GHz) processor (2400-MHz FSB, 4-MB L2 cache, dual core, 6 W), a graphics subsystem with UMA memory, 4-GB of system memory, 32-GB of eMMC storage, and a non-Windows 10 operating system	L85673-001
	Thermal Pad Replacement Kit (not illustrated)	L76600-001
(6)	Power cable	L73311-001
(7a)	USB/audio board (does not include cables)	L70818-001
(7b)	USB/audio board high-power cable	L73309-001
(7c)	USB/audio board low-power cable	L73310-001
(8a)	Touchpad (includes touchpad bracket, does not include cable):	
	In mineral silver finish	L73315-001
	In natural silver finish	L73316-001
(8b)	Touchpad cable (includes double-sided adhesive)	L73312-001
(8c)	Touchpad bracket (included in the touchpad spare part kit)	
(9)	Battery (2-cell, 47 Wh, 6.15-Ah, Li-Ion, includes cable)	L42583-005 and L42583-006
	Battery bracket (not illustrated)	L79370-001
(10)	Bottom cover (includes shielding, heat sink grounding pads, and the RJ-45 cover):	
	In mineral silver finish	L73319-001
	In natural silver finish	L73320-001
	Rubber Feet Kit (includes front and rear rubber foot strips):	
	In mineral silver finish	L73321-001
	In natural silver finish	L73322-001
	Screw Cover Kit (includes screw covers):	
	In mineral silver finish	L76599-001
	In natural silver finish	L73740-001

Display components

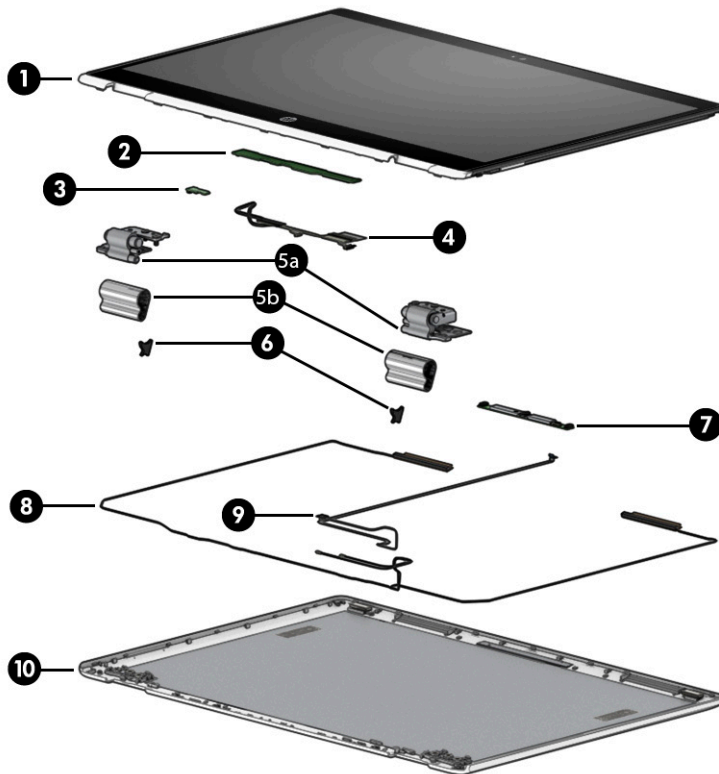

Table 3-2 Display component descriptions and spare part information

Item	Component	Spare part number
(1)	Display panel assembly:	
	14.0-in, FHD antiglare, UWVA, 250 touchscreen	L73303-001
	14.0-in, FHD antiglare, 250 touchscreen USI	L77983-001
	14.0-in, HD antiglare, SVA, 220 touchscreen	L73304-001
	14.0-in, HD antiglare, 220 touchscreen USI	L77984-001
(2)	Touch control board (includes double-sided adhesive):	
	For use only on computer models equipped with a stylus	L78118-001
	For use only on computer models not equipped with a stylus	L76601-001
(3)	G-sensor board (includes double-sided adhesive)	L73317-001
(4)	Display panel cable (includes the touch control board cable and the G-sensor board cable)	L73313-001
	Display Hinge Kit , includes:	L73326-001
(5a)	Left and right display hinges	
(5b)	Left and right display hinge covers	
(6)	Display hinge caps (2)	L76602-001
(7)	Webcam/microphone module (includes double-sided adhesive)	L73302-001

Table 3-2 Display component descriptions and spare part information (continued)

Item	Component	Spare part number
(8)	Webcam/microphone module cable (includes double-sided adhesive)	L73314-001
(7)	Wireless Antenna Kit (includes auxiliary and main wireless antenna cables and transceivers and adhesive)	L73325-001
(8)	Display back cover	L73323-001

Miscellaneous parts

Table 3-3 Miscellaneous components and descriptions

Component	Spare part number
45 W AC adapter (non-PFC, USB Type-C, 1.8-m, 3-pin)	L43407-001
HP 14.0-in, black reversible sleeve	L67189-001
HP X3000 entry-level wireless mouse	684978-001
HP X3000 mouse in Pike silver finish	942296-001
Pen (HVAR, USI, active)	L73384-001
Power cord (C13 connector, 1.00-m, premium with sticker):	
For use in Australia	L19358-001
For use in Denmark	L19360-001
For use in Europe	L19361-001
For use in India	L19363-001
For use in Japan	L19365-001
For use in North America	L19367-001
For use in the United Kingdom	L19373-001
Screw Kit	L73328-001

4 Removal and replacement procedures preliminary requirements

Tools required

You will need the following tools to complete the removal and replacement procedures:

- Flat-bladed screw driver
- Magnetic screw driver
- Phillips P0 and P1 screw drivers

Service considerations

The following sections include some of the considerations that you must keep in mind during disassembly and assembly procedures.

 **NOTE:** As you remove each subassembly from the computer, place the subassembly (and all accompanying screws) away from the work area to prevent damage.

Plastic parts

 **IMPORTANT:** Using excessive force during disassembly and reassembly can damage plastic parts. Use care when handling the plastic.

Cables and connectors

 **IMPORTANT:** When servicing the computer, be sure that cables are placed in their proper locations during the reassembly process. Improper cable placement can damage the computer.

Cables must be handled with extreme care to avoid damage. Apply only the tension required to unseat or seat the cables during removal and insertion. Handle cables by the connector whenever possible. In all cases, avoid bending, twisting, or tearing cables. Be sure that cables are routed in such a way that they cannot be caught or snagged by parts being removed or replaced. Handle flex cables with extreme care; these cables tear easily.

Drive handling



IMPORTANT: Drives are fragile components that must be handled with care. To prevent damage to the computer, damage to a drive, or loss of information, observe these precautions:

- Before removing or inserting a hard drive, shut down the computer. If you are unsure whether the computer is off or in Hibernation, turn the computer on, and then shut it down through the operating system.
- Before handling a drive, be sure that you are discharged of static electricity. While handling a drive, avoid touching the connector.
- Before removing an optical drive, be sure that a disc is not in the drive and be sure that the optical drive tray is closed.
- Handle drives on surfaces covered with at least 2.54 cm (one in) of shock-proof foam.
- Avoid dropping drives from any height onto any surface.
- After removing a hard drive or an optical drive, place it in a static-proof bag.
- Avoid exposing an internal hard drive to products that have magnetic fields, such as monitors or speakers.
- Avoid exposing a drive to temperature extremes or liquids.
- If a drive must be mailed, place the drive in a bubble pack mailer or other suitable form of protective packaging and label the package “FRAGILE.”

Electrostatic discharge damage

Electronic components are sensitive to electrostatic discharge (ESD). Circuitry design and structure determine the degree of sensitivity. Networks built into many integrated circuits provide some protection, but in many cases, ESD contains enough power to alter device parameters or melt silicon junctions.

A discharge of static electricity from a finger or other conductor can destroy static-sensitive devices or microcircuitry. Even if the spark is neither felt nor heard, damage may have occurred.

An electronic device exposed to ESD may not be affected at all and can work perfectly throughout a normal cycle. Or the device may function normally for a while, then degrade in the internal layers, reducing its life expectancy.



IMPORTANT: To prevent damage to the tablet when you are removing or installing internal components, observe these precautions:

- Keep components in their electrostatic-safe containers until you are ready to install them.
- Before touching an electronic component, discharge static electricity by using the guidelines described in this section.
- Avoid touching pins, leads, and circuitry. Handle electronic components as little as possible.
- If you remove a component, place it in an electrostatic-safe container.

The following table shows how humidity affects the electrostatic voltage levels generated by different activities.



IMPORTANT: A product can be degraded by as little as 700 V.

Table 4-1 Typical electrostatic voltage levels

Event	Typical electrostatic voltage levels		
	Relative humidity		
	10%	40%	55%
Walking across carpet	35,000 V	15,000 V	7,500 V
Walking across vinyl floor	12,000 V	5,000 V	3,000 V
Motions of bench worker	6,000 V	800 V	400 V
Removing DIPS from plastic tube	2,000 V	700 V	400 V
Removing DIPS from vinyl tray	11,500 V	4,000 V	2,000 V
Removing DIPS from polystyrene foam	14,500 V	5,000 V	3,500 V
Removing bubble pack from PCB	26,500 V	20,000 V	7,000 V
Packing PCBs in foam-lined box	21,000 V	11,000 V	5,000 V

Packaging and transporting guidelines

Follow these grounding guidelines when packaging and transporting equipment:

- To avoid hand contact, transport products in static-safe tubes, bags, or boxes.
- Protect ESD-sensitive parts and assemblies with conductive or approved containers or packaging.
- Keep ESD-sensitive parts in their containers until the parts arrive at static-free workstations.
- Place items on a grounded surface before removing items from their containers.
- Always be properly grounded when touching a component or assembly.
- Store reusable ESD-sensitive parts from assemblies in protective packaging or nonconductive foam.
- Use transporters and conveyors made of antistatic belts and roller bushings. Be sure that mechanized equipment used for moving materials is wired to ground and that proper materials are selected to avoid static charging. When grounding is not possible, use an ionizer to dissipate electric charges.

Workstation guidelines

Follow these grounding workstation guidelines:

- Cover the workstation with approved static-shielding material.
- Use a wrist strap connected to a properly grounded work surface and use properly grounded tools and equipment.
- Use conductive field service tools, such as cutters, screw drivers, and vacuums.
- When fixtures must directly contact dissipative surfaces, use fixtures made only of static-safe materials.
- Keep the work area free of nonconductive materials, such as ordinary plastic assembly aids and polystyrene foam.
- Handle ESD-sensitive components, parts, and assemblies by the case or PCM laminate. Handle these items only at static-free workstations.
- Avoid contact with pins, leads, or circuitry.
- Turn off power and input signals before inserting or removing connectors or test equipment.

Equipment guidelines

Grounding equipment must include either a wrist strap or a foot strap at a grounded workstation.

- When seated, wear a wrist strap connected to a grounded system. Wrist straps are flexible straps with a minimum of $1\text{ M}\Omega \pm 10\%$ resistance in the ground cords. To provide proper ground, wear a strap snugly against the skin at all times. On grounded mats with banana-plug connectors, use alligator clips to connect a wrist strap.
- When standing, use foot straps and a grounded floor mat. Foot straps (heel, toe, or boot straps) can be used at standing workstations and are compatible with most types of shoes or boots. On conductive floors or dissipative floor mats, use foot straps on both feet with a minimum of $1\text{ M}\Omega \pm 10\%$ resistance between the operator and ground. To be effective, the conductive must be worn in contact with the skin.

The following grounding equipment is recommended to prevent electrostatic damage:

- Antistatic tape
- Antistatic smocks, aprons, and sleeve protectors
- Conductive bins and other assembly or soldering aids
- Nonconductive foam
- Conductive tabletop workstations with ground cords of $1\text{ M}\Omega \pm 10\%$ resistance
- Static-dissipative tables or floor mats with hard ties to the ground
- Field service kits
- Static awareness labels
- Material-handling packages
- Nonconductive plastic bags, tubes, or boxes
- Metal tote boxes
- Electrostatic voltage levels and protective materials

The following table lists the shielding protection provided by antistatic bags and floor mats.

Table 4-2 Shielding protection provided by antistatic bags and floor mats

Material	Use	Voltage protection level
Antistatic plastics	Bags	1,500 V
Carbon-loaded plastic	Floor mats	7,500 V
Metallized laminate	Floor mats	5,000 V

5 Removal and replacement procedures

This chapter provides removal and replacement procedures for Authorized Service Provider only parts.

 **IMPORTANT:** Components described in this chapter should be accessed only by an authorized service provider. Accessing these parts can damage the computer or void the warranty.

IMPORTANT: This computer does not have user-replaceable parts. Only HP authorized service providers should perform the removal and replacement procedures described here. Accessing the internal part could damage the computer or void the warranty.

Component replacement procedures

 **NOTE:** Details about your computer, including model, serial number, product key, and length of warranty, are on the service tag at the bottom of your computer. See [Labels on page 9](#) for details.

 **NOTE:** HP continually improves and changes product parts. For complete and current information on supported parts for your computer, go to <http://partsurfer.hp.com>, select your country or region, and then follow the on-screen instructions.

There are as many as 38 screws that must be removed, replaced, and/or loosened when servicing Authorized Service Provider only parts. Make special note of each screw size and location during removal and replacement.

Bottom cover

 **NOTE:** The bottom cover spare part kit includes system board shielding and keyboard/top cover magnets.

Table 5-1 Bottom cover description and spare part number information

Description	Spare part number
In mineral silver finish	L73319-001
In natural silver finish	L73320-001

Before disassembling the computer, follow these steps:

1. Shut down the computer. If you are unsure whether the computer is off or in Hibernation, turn the computer on, and then shut it down through the operating system.
2. Disconnect all external devices connected to the computer.
3. Disconnect the power from the computer by first unplugging the power cord from the AC outlet, and then unplugging the AC adapter from the computer.

Remove the bottom cover:

1. Turn the computer upside down with the front toward you.
2. Remove the front and rear foot strips **(1)**.

The front and rear foot strips are included in the Rubber Feet Kit, spare part numbers L73321-001 (in mineral silver finish) and L73322-001 (in natural silver finish).

3. Remove the screw covers (2).

The screw covers are included in the Screw Cover Kit, spare part numbers L76599-001 (in mineral silver finish) and L73740-001 (in natural silver finish).

4. Remove the two Phillips M2.0×4.2 screws (3) that secure the bottom cover to the computer.
5. Remove the five Phillips M2.0×7.7 screws (4) that secure the bottom cover to the computer.

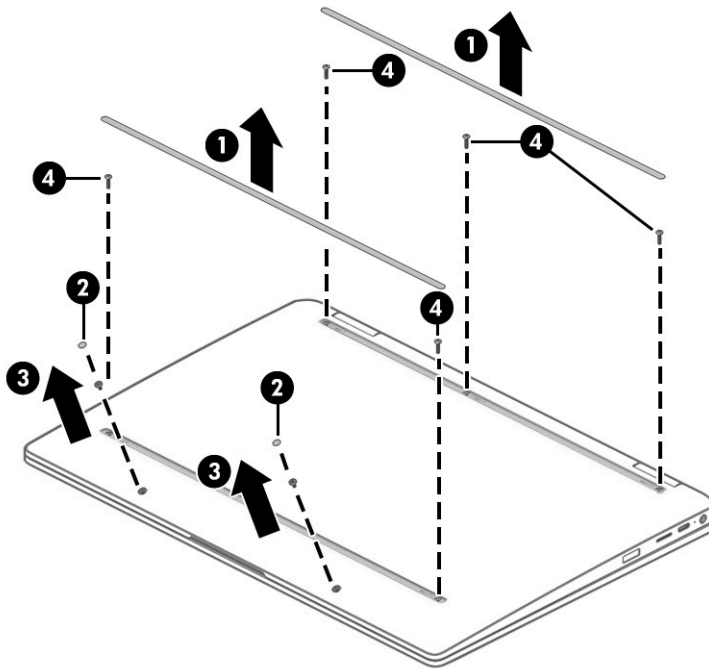

6. Insert a case utility tool (1) or similar thin plastic tool into the display hinge areas of the bottom cover.
7. Separate the rear edge (2) of the bottom cover from the keyboard/top cover.

8. Remove the bottom cover (3).

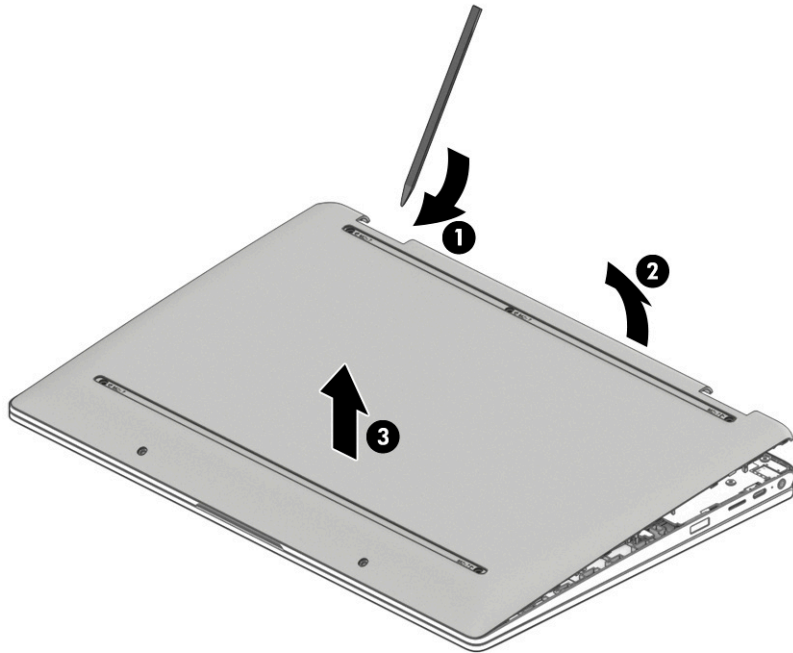

Reverse this procedure to install the bottom cover.

Battery

Table 5-2 Battery description and spare part number information

Description	Spare part number
2-cell, 47 Wh, 6.15-Ah, Li-ion battery (includes cable)	L42583-005 and L42583-006
Battery bracket	L79370-001

Before removing the battery, follow these steps:

1. Shut down the computer. If you are unsure whether the computer is off or in Hibernation, turn the computer on, and then shut it down through the operating system.
2. Disconnect all external devices connected to the computer.
3. Disconnect the power from the computer by first unplugging the power cord from the AC outlet, and then unplugging the AC adapter from the computer.
4. Remove the bottom cover (see [Bottom cover on page 22](#)).

Remove the battery:

1. Release the retention tape (1) that secures the battery cable, and then disconnect the battery cable (2) from the system board.
2. Remove the four Phillips M2.0×4.2 screws (3) that secure the battery to the keyboard/top cover.

3. Remove the battery (4).

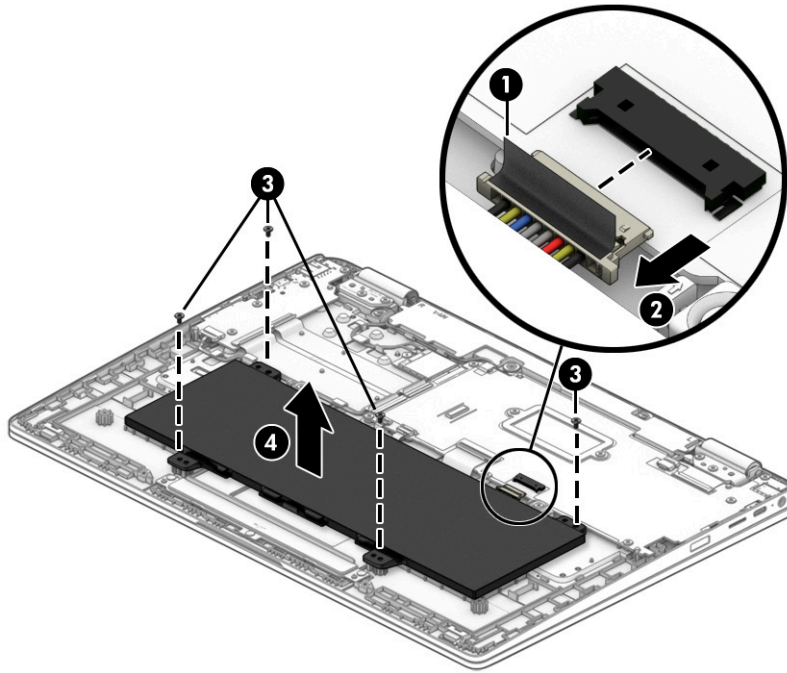

Reverse this procedure to install the battery.

WLAN module

Table 5-3 WLAN module description and spare part number information

Description	Spare part number
Intel 9560 ac 2×2 MU-MIMO + Bluetooth 5.0 M.2 non-vPro CNVi WW with 2 antennas	L41693-005



IMPORTANT: To prevent an unresponsive system, replace the wireless module only with a wireless module authorized for use in the computer by the governmental agency that regulates wireless devices in your country or region. If you replace the module and then receive a warning message, remove the module to restore device functionality, and then contact technical support.

Before removing the WLAN module, follow these steps:

1. Turn off the computer. If you are unsure whether the computer is off or in Hibernation, turn the computer on, and then shut it down through the operating system.
2. Disconnect the power from the computer by first unplugging the power cord from the AC outlet, and then unplugging the AC adapter from the computer.
3. Disconnect all external devices from the computer.
4. Remove the bottom cover (see [Bottom cover on page 22](#)).
5. Disconnect the battery cable from the system board (see [Battery on page 24](#)).

Remove the WLAN module:

1. Disconnect the WLAN antenna cables **(1)** from the WLAN module.



NOTE: The #1/white WLAN antenna cable connects to the WLAN module **#1/Main** terminal. The #2/ black WLAN antenna cable connects to the WLAN module **#2/Aux** terminal.

2. Remove the Phillips M2.0×2.9 screw **(2)** that secures the WLAN module to the keyboard/top cover.

3. Remove the WLAN module (3) by pulling the module away from the slot at an angle.

 **NOTE:** WLAN modules are designed with a notch to prevent incorrect insertion.

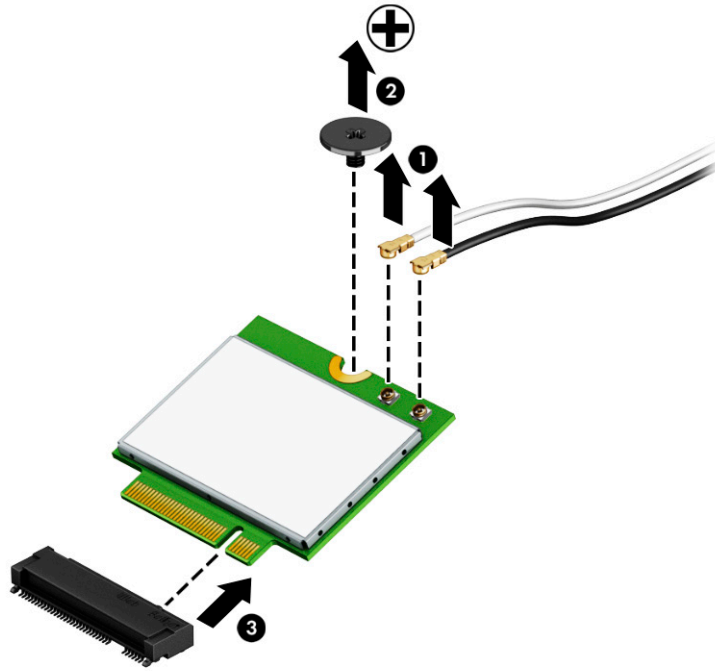

Reverse this procedure to install the WLAN module.

USB/audio board cable

 **NOTE:** The USB/audio board high-power cable is available using spare part number L73309-001. The USB/audio board low-power cable is available using spare part number L73310-001.

Before removing the USB/audio board cables, follow these steps:

1. Shut down the computer. If you are unsure whether the computer is off or in Hibernation, turn the computer on, and then shut it down through the operating system.
2. Disconnect all external devices connected to the computer.
3. Disconnect the power from the computer by first unplugging the power cord from the AC outlet, and then unplugging the AC adapter from the computer.
4. Remove the bottom cover (see [Bottom cover on page 22](#)).
5. Disconnect the battery cable from the system board (see [Battery on page 24](#)).

Remove the USB/audio board cables:

1. Release the ZIF connectors **(1)** to which USB/audio board high-power cable and low-power cable are connected, and then disconnect the USB/audio board high-power cable and low-power cable from the system board.
2. Release the ZIF connectors **(2)** to which USB/audio board high-power cable and low-power cable are connected, and then disconnect the USB/audio board high-power cable and low-power cable from the USB/audio board.
3. Remove the USB/audio board high-power cable **(3)** and low-power cable.

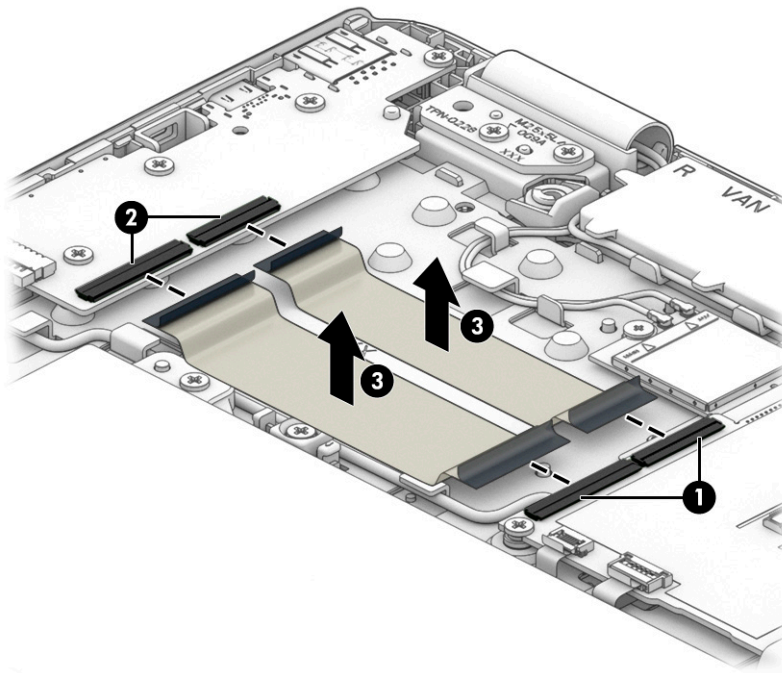

Reverse this procedure to install the USB/audio board high-power and low-power cables.

USB/audio board



NOTE: The USB/audio board spare part kit does not include the USB/audio board high-power and low-power cables. The USB/audio board high-power cable is available using spare part number L73309-001. The USB/audio board low-power cable is available using spare part number L73310-001.

Table 5-4 USB/audio board description and spare part number information

Description	Spare part number
USB/audio board (includes 2 USB ports and 1 audio combo jack)	L70818-001

Before removing the USB/audio board, follow these steps:

1. Shut down the computer. If you are unsure whether the computer is off or in Hibernation, turn the computer on, and then shut it down through the operating system.
2. Disconnect all external devices connected to the computer.
3. Disconnect the power from the computer by first unplugging the power cord from the AC outlet, and then unplugging the AC adapter from the computer.
4. Remove the bottom cover (see [Bottom cover on page 22](#)).
5. Disconnect the battery cable from the system board (see [Battery on page 24](#)).

Remove the USB/audio board:

1. Release the ZIF connectors **(1)** to which USB/audio board high-power cable and low-power cable are connected, and then disconnect the USB/audio board high-power cable and low-power cable from the system board.
2. Disconnect the power cable **(2)** from the USB/audio board.
3. Remove the four Phillips M2.0×4.2 screws **(3)** that secure the USB/audio board to the keyboard/top cover.

- Remove the USB/audio board (4).

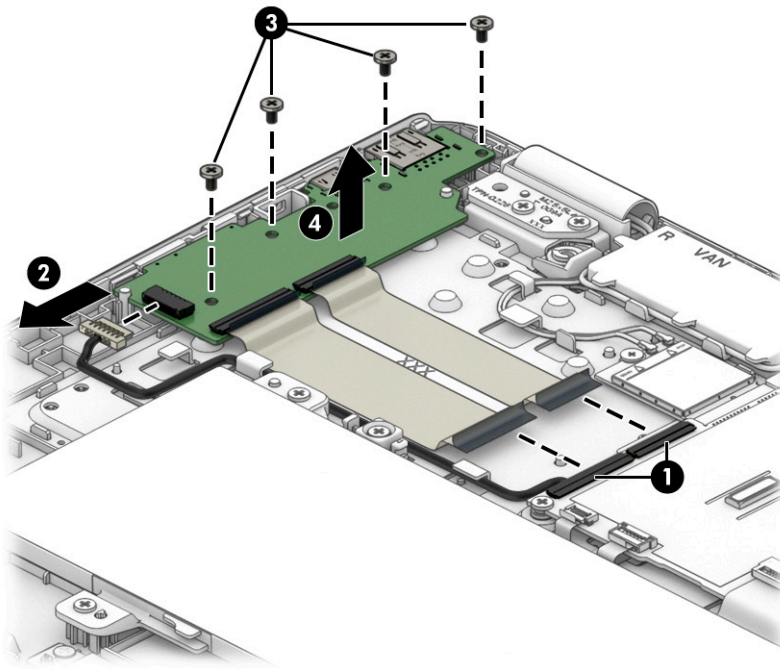

Reverse this procedure to install the USB/audio board and cables.

System board



NOTE: The system board spare part kit includes replacement thermal pads. Additional replacement thermal pads are available in the Thermal Pad Replacement Kit, spare part number L76600-001.

Table 5-5 System board description and spare part number information

Description	Spare part number
For use only on computer models equipped with a backlit keyboard/top cover:	
Equipped with an Intel Pentium N5000 1.1 GHz (turbo up to 2.7 GHz) processor (2400-MHz FSB, 4-MB L2 cache, quad core, 6 W), a graphics subsystem with UMA memory, 8-GB of system memory, 128-GB of eMMC storage, and a non-Windows 10 operating system	L73300-001
Equipped with an Intel Pentium N5000 1.1 GHz (turbo up to 2.7 GHz) processor (2400-MHz FSB, 4-MB L2 cache, quad core, 6 W), a graphics subsystem with UMA memory, 8-GB of system memory, 64-GB of eMMC storage, and a non-Windows 10 operating system	L70811-001
Equipped with an Intel Pentium N5000 1.1 GHz (turbo up to 2.7 GHz) processor (2400-MHz FSB, 4-MB L2 cache, quad core, 6 W), a graphics subsystem with UMA memory, 4-GB of system memory, 64-GB of eMMC storage, and a non-Windows 10 operating system	L70810-001
Equipped with an Intel Celeron N4000 1.1 GHz (turbo up to 2.6 GHz) processor (2400-MHz FSB, 4-MB L2 cache, dual core, 6 W), a graphics subsystem with UMA memory, 4-GB of system memory, 64-GB of eMMC storage, and a non-Windows 10 operating system	L70809-001
Equipped with an Intel Celeron N4000 1.1 GHz (turbo up to 2.6 GHz) processor (2400-MHz FSB, 4-MB L2 cache, dual core, 6 W), a graphics subsystem with UMA memory, 4-GB of system memory, 32-GB of eMMC storage, and a non-Windows 10 operating system	L70808-001
For use only on computer models equipped with a non-backlit keyboard/top cover:	

Table 5-5 System board description and spare part number information (continued)

Description	Spare part number
Equipped with an Intel Pentium N5000 1.1 GHz (turbo up to 2.7 GHz) processor (2400-MHz FSB, 4-MB L2 cache, quad core, 6 W), a graphics subsystem with UMA memory, 8-GB of system memory, 128-GB of eMMC storage, and a non-Windows 10 operating system	L85681-001
Equipped with an Intel Pentium N5000 1.1 GHz (turbo up to 2.7 GHz) processor (2400-MHz FSB, 4-MB L2 cache, quad core, 6 W), a graphics subsystem with UMA memory, 8-GB of system memory, 64-GB of eMMC storage, and a non-Windows 10 operating system	L85676-001
Equipped with an Intel Pentium N5000 1.1 GHz (turbo up to 2.7 GHz) processor (2400-MHz FSB, 4-MB L2 cache, quad core, 6 W), a graphics subsystem with UMA memory, 4-GB of system memory, 64-GB of eMMC storage, and a non-Windows 10 operating system	L85675-001
Equipped with an Intel Celeron N4000 1.1 GHz (turbo up to 2.6 GHz) processor (2400-MHz FSB, 4-MB L2 cache, dual core, 6 W), a graphics subsystem with UMA memory, 4-GB of system memory, 64-GB of eMMC storage, and a non-Windows 10 operating system	L85674-001
Equipped with an Intel Celeron N4000 1.1 GHz (turbo up to 2.6 GHz) processor (2400-MHz FSB, 4-MB L2 cache, dual core, 6 W), a graphics subsystem with UMA memory, 4-GB of system memory, 32-GB of eMMC storage, and a non-Windows 10 operating system	L85673-001

Before removing the system board, follow these steps:

1. Shut down the computer. If you are unsure whether the computer is off or in Hibernation, turn the computer on, and then shut it down through the operating system.
2. Disconnect all external devices connected to the computer.
3. Disconnect the power from the computer by first unplugging the power cord from the AC outlet, and then unplugging the AC adapter from the computer.
4. Remove the bottom cover (see [Bottom cover on page 22](#)).
5. Disconnect the battery cable from the system board (see [Battery on page 24](#)).
6. Remove the WLAN module (see [WLAN module on page 26](#)).

Remove the system board:

1. Disconnect/release the following cables:
 - (1) Power cable
 - (2) Power cable retention clips
 - (3) USB/audio board high-power and low-power ZIF connector cable
 - (4) Webcam/microphone module cable retention tape
 - (5) Webcam/microphone module cable
 - (6) Speaker cable
 - (7) Display panel cable adhesive support strip
 - (8) Display panel cable
 - (9) Touchpad ZIF connector cable
 - (10) Keyboard ZIF connector cable

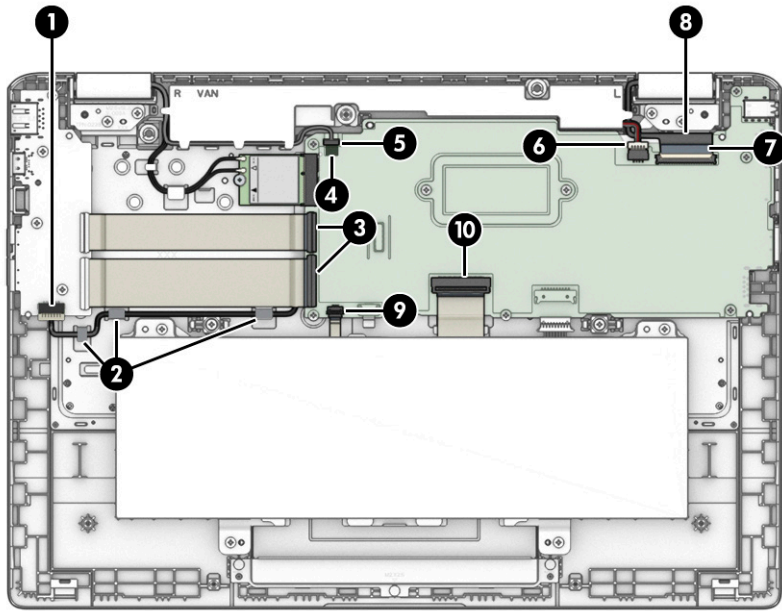

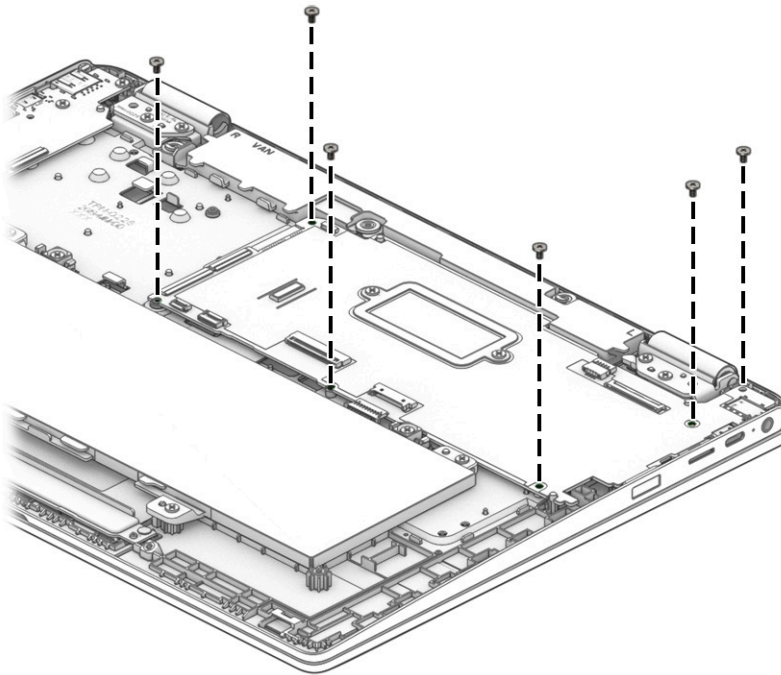

2. Remove the six Phillips M2.0×4.2 screws that secure the system board to the keyboard/top cover.

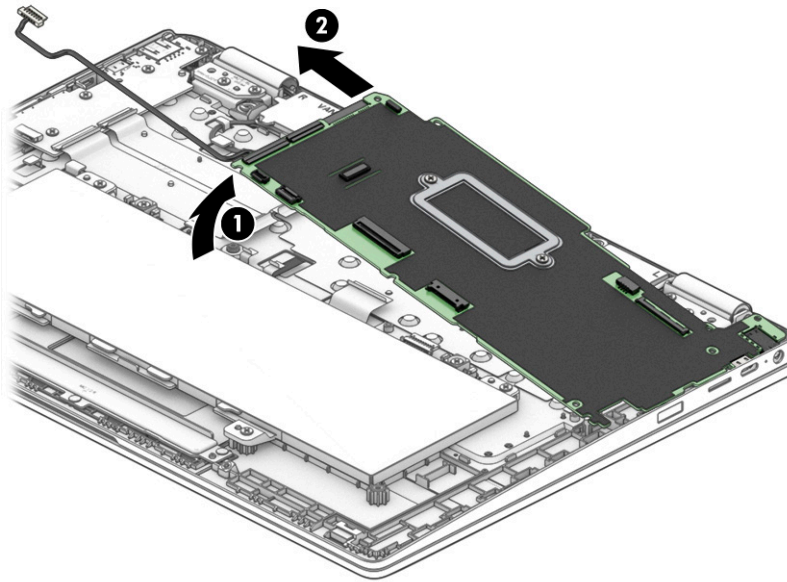

3. Lift the left side (1) of the system board until it rests at an angle.

4. Remove the system board (2) by sliding it up and to the left at an angle.



 **NOTE:** The thermal material must be thoroughly cleaned from the surfaces of the keyboard/top cover and the system board components each time the system board is removed.

A thermal pad is used on the processor (1) and the keyboard/top cover section (2) that services it. Replacement thermal pads are available in the Thermal Pad Replacement Kit, spare part number L76600-001.

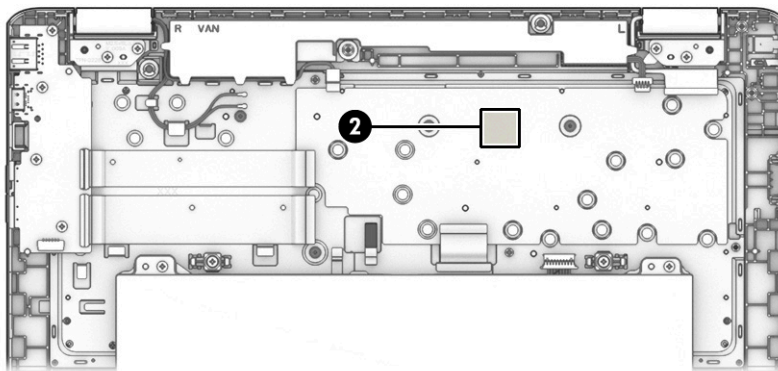
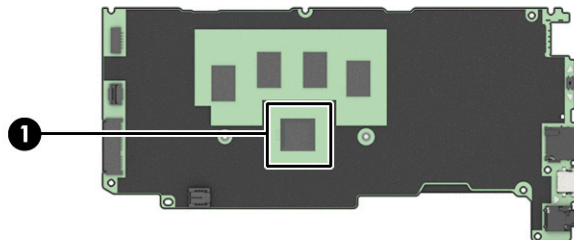

Reverse this procedure to install the system board.

Power cable

Table 5-6 Power cable description and spare part number information

Description	Spare part number
Power cable	L73311-001

Before removing the power cable, follow these steps:

1. Shut down the computer. If you are unsure whether the computer is off or in Hibernation, turn the computer on, and then shut it down through the operating system.
2. Disconnect all external devices connected to the computer.
3. Disconnect the power from the computer by first unplugging the power cord from the AC outlet, and then unplugging the AC adapter from the computer.
4. Remove the bottom cover (see [Bottom cover on page 22](#)).
5. Disconnect the battery cable from the system board (see [Battery on page 24](#)).
6. Remove the WLAN module (see [WLAN module on page 26](#)).
7. Remove the system board (see [System board on page 30](#)).

Remove the power cable:

1. Turn the system board upside down with the front toward you.
2. Disconnect the power cable from the system board.

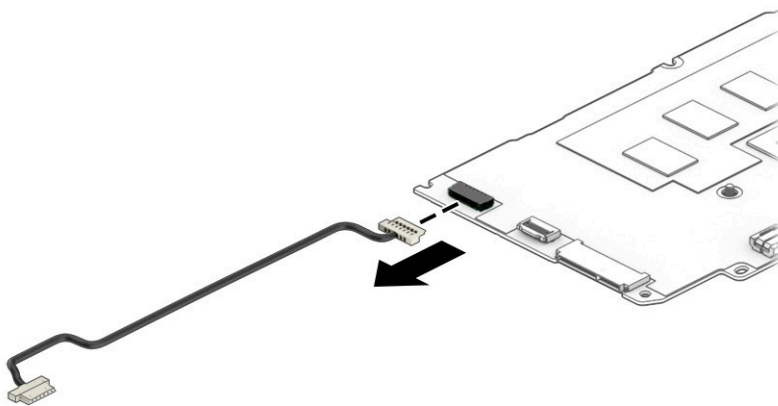

Reverse this procedure to install the power cable.

Speakers

Table 5-7 Speakers description and spare part number information

Description	Spare part number
Speaker Kit (includes left and right speakers, cables, and 3 rubber isolators)	L73318-001

Before removing the speakers, follow these steps:

1. Turn off the computer. If you are unsure whether the computer is off or in Hibernation, turn the computer on, and then shut it down through the operating system.
2. Disconnect the power from the computer by first unplugging the power cord from the AC outlet, and then unplugging the AC adapter from the computer.
3. Disconnect all external devices from the computer.
4. Remove the bottom cover (see [Bottom cover on page 22](#)).
5. Disconnect the battery cable from the system board (see [Battery on page 24](#)).

Remove the speakers:

1. Release the webcam/microphone module cable from the retention clips (1) and routing channel built into the speakers.
2. Disconnect the speaker cable (2) from the system board.
3. Remove the speakers (3).

 **NOTE:** When removing the speakers, make note of the location and condition of the rubber isolators (4). These isolators are critical to the performance of the speakers. The absence of these isolators or damage to them can degrade the speakers performance.

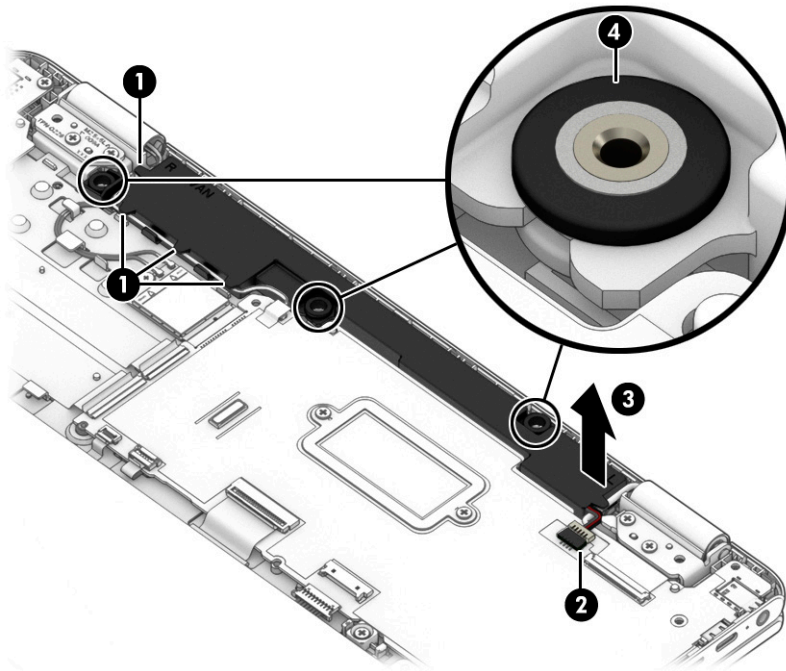

Reverse this procedure to install the speakers.

Display assembly

 **NOTE:** The display assembly is spared at the subcomponent level. For display assembly spare part information, see the individual removal subsections.

Before removing the display assembly, follow these steps:

1. Shut down the computer. If you are unsure whether the computer is off or in Hibernation, turn the computer on, and then shut it down through the operating system.
2. Disconnect all external devices connected to the computer.
3. Disconnect the power from the computer by first unplugging the power cord from the AC outlet, and then unplugging the AC adapter from the computer.
4. Remove the bottom cover (see [Bottom cover on page 22](#)).
5. Disconnect the battery cable from the system board (see [Battery on page 24](#)).

Remove the display assembly:

1. Disconnect the WLAN antenna cables **(1)** from the WLAN module.

 **NOTE:** The #1/white WLAN antenna cable connects to the WLAN module **#1/Main** terminal. The #2/ black WLAN antenna cable connects to the WLAN module **#2/Aux** terminal.

2. Release the retention tape **(2)** that secures the webcam/microphone module cable, and then disconnect the webcam/microphone module cable **(3)** from the system board.
3. Release the wireless antenna cables and the webcam/microphone module cable from the retention clips **(4)** and routing channel built into the keyboard/top cover and speakers.
4. Release the adhesive support strip **(5)** that secures the display panel cable to the system board.
5. Disconnect the display panel cable **(6)** from the system board.

6. Release the display panel cable from the retention clip (7) and routing channel built into the keyboard/top cover.

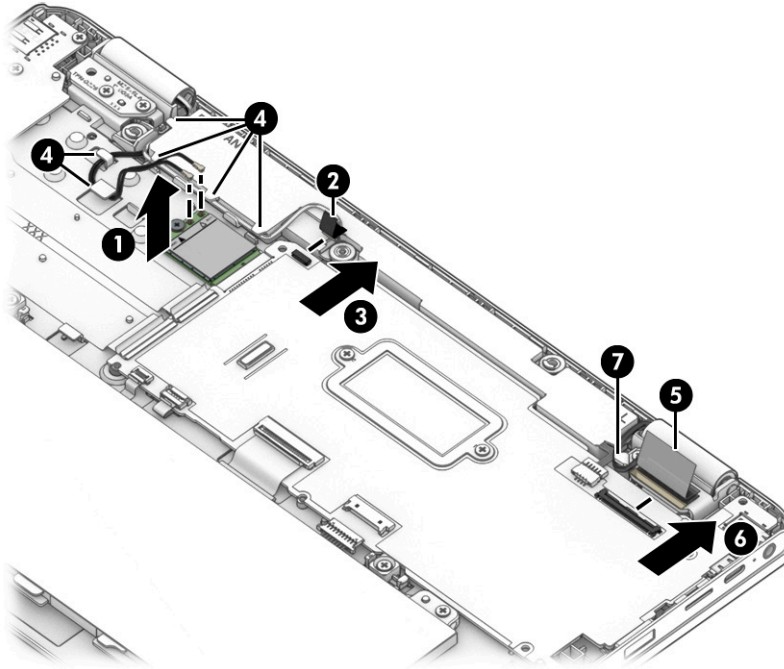

7. Remove the four Phillips M2.5×5.7 screws that secure the display assembly to the keyboard/top cover.

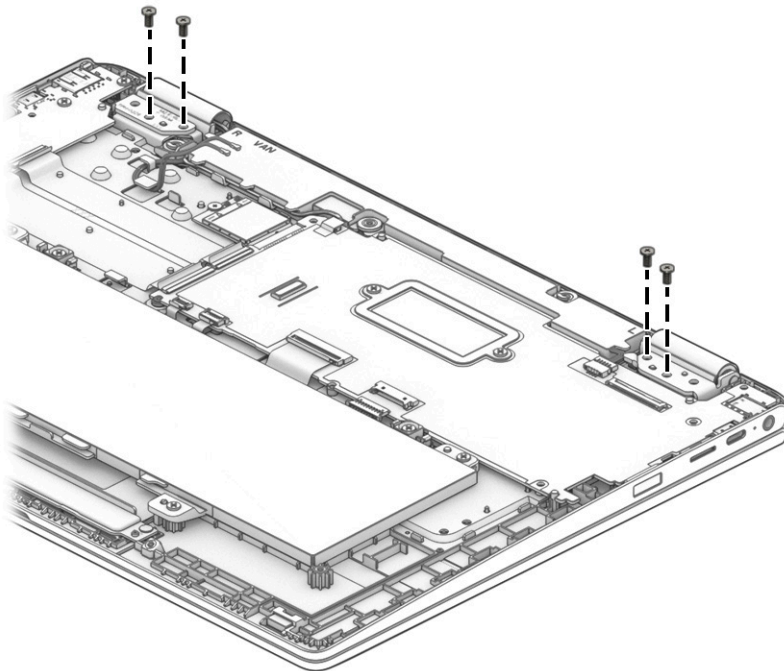

8. Swing the keyboard/top cover (1) up and away from the display assembly.

9. Slide the display assembly (2) away from the keyboard/top cover and remove the display assembly.

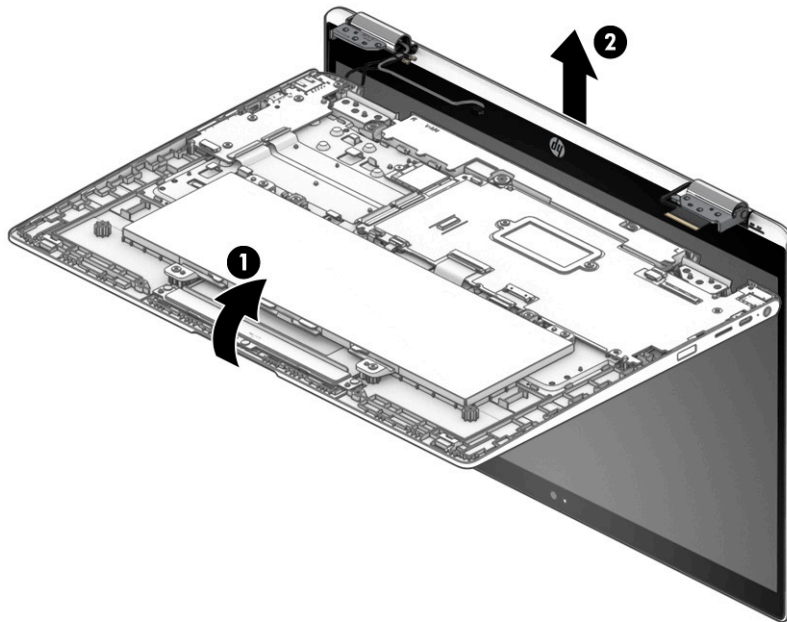

10. If it is necessary to replace the display panel assembly or any of the display assembly subcomponents:
- Remove the hinge cap (1) from the display right hinge.
The hinge cap is available using spare part number L76602-001.
 - Release the display panel cable (2) from the opening in the display right hinge.

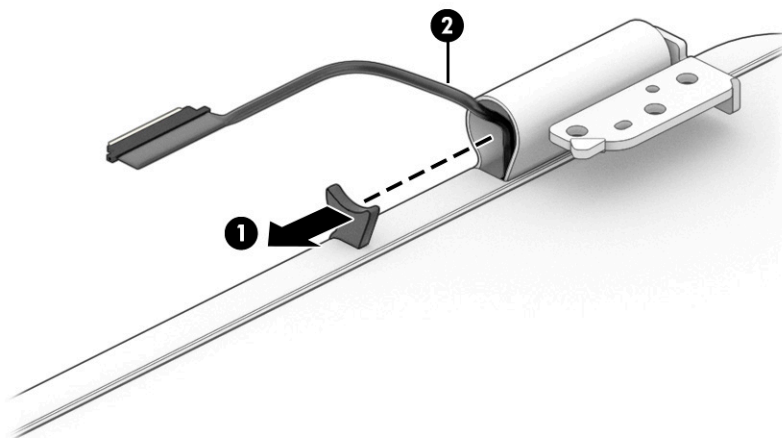

- c. Insert a case utility tool (1) or similar thin plastic tool into the top edge of the display panel assembly and separate the assembly (2) from the display back cover.

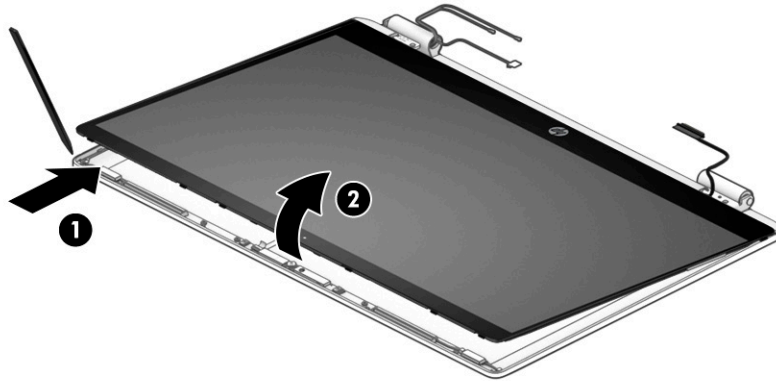

- d. Remove the display panel assembly and display panel cable.

The display panel assembly is available using the following spare part numbers

- L73303-001 – 14.0-in, FHD antiglare, UWVA, 250 touchscreen
- L77983-001 – 14.0-in, FHD antiglare, 250 touchscreen USI
- L73304-001 – 14.0-in, HD antiglare, SVA, 220 touchscreen
- L77984-001 – 14.0-in, HD antiglare, 220 touchscreen USI

11. If it is necessary to replace the touch control board:

- a. Remove the display panel assembly.

 **IMPORTANT:** Before placing the display panel assembly with the panel facing down, make sure there are no foreign objects (tools, screws) on the work surface. Failure to follow this note can lead to damage to the display panel assembly.

- b. Position the display panel assembly with the panel facing down.
- c. Release the ZIF connectors (1) to which the touch control board cables are connected, and then disconnect the touch control board cables from the touch control board.
- d. Release the retention tape (2) that secures the display panel cable, and then disconnect the display panel cable (3) from the touch control board.

- e. Detach the touch control board (4) from the display back cover. (The touch control board is attached to the display back cover with double-sided adhesive.)

The touch control board is available using spare part numbers L78118-001 (for use only on computer models equipped with a stylus) and L76601-001 (for use only on computer models not equipped with a stylus).

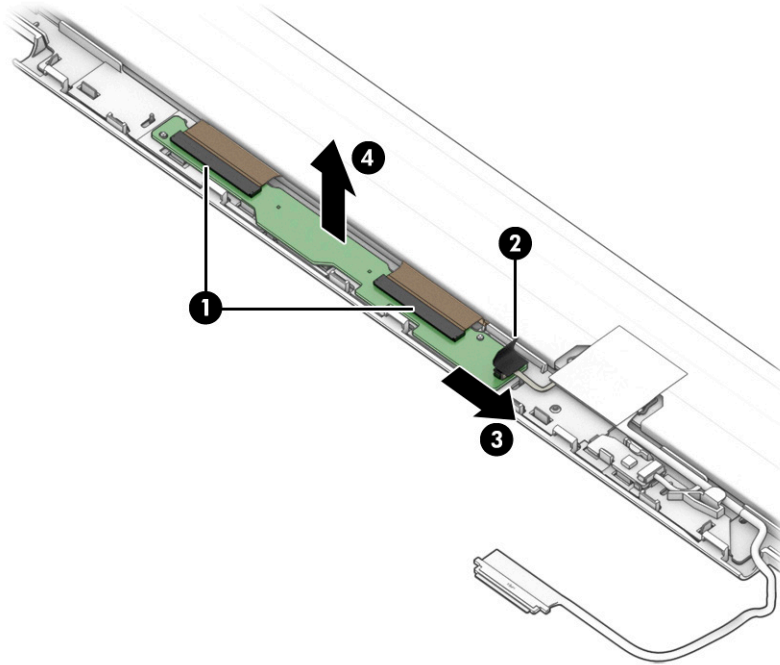

12. If it is necessary to replace the G-sensor board:

- a. Remove the display panel assembly.

 **IMPORTANT:** Before placing the display panel assembly with the panel facing down, make sure there are no foreign objects (tools, screws) on the work surface. Failure to follow this note can lead to damage to the display panel assembly.

- b. Position the display panel assembly with the panel facing down.
- c. Release the retention tape (1) that secures the display panel cable, and then disconnect the display panel cable (2) from the G-sensor board.

- d. Detach the G-sensor board (3) from the display back cover. (The G-sensor board is attached to the display back cover with double-sided adhesive.)

The G-sensor board is available using spare part number L73317-001.

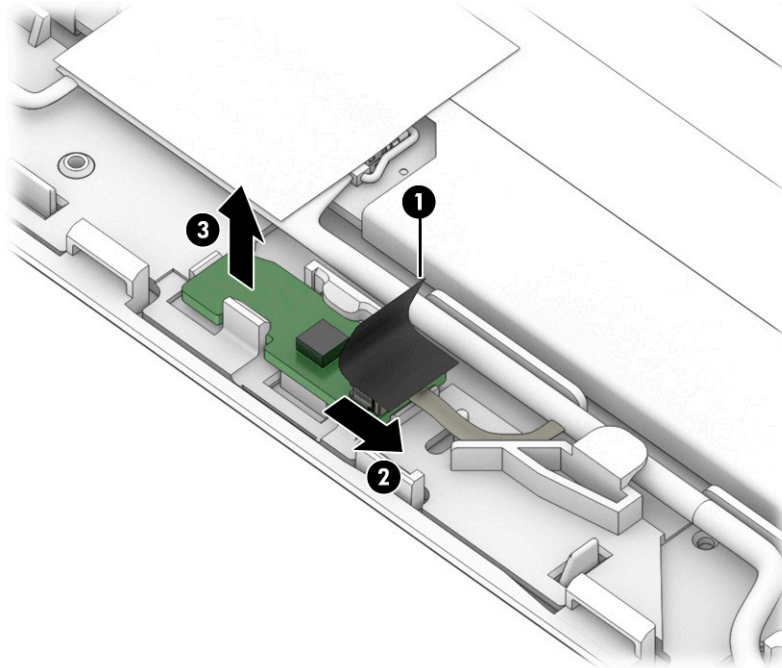

13. If it is necessary to replace the display panel cable:

- a. Remove the display panel assembly.

 **IMPORTANT:** Before placing the display panel assembly with the panel facing down, make sure there are no foreign objects (tools, screws) on the work surface. Failure to follow this note can lead to damage to the display panel assembly.

- b. Position the display panel assembly with the panel facing down.
- c. Release the adhesive support strip (1) that secures the display panel cable to the display panel.
- d. Swing the release bar (2) up and back to release the display panel cable.
- e. Disconnect the display panel cable (3) from the display panel.
- f. Release the retention tape (4) that secures the display panel cable, and then disconnect the display panel cable (5) from the touch control board.

- g.** Release the retention tape (6) that secures the display panel cable, and then disconnect the display panel cable (7) from the G-sensor board.

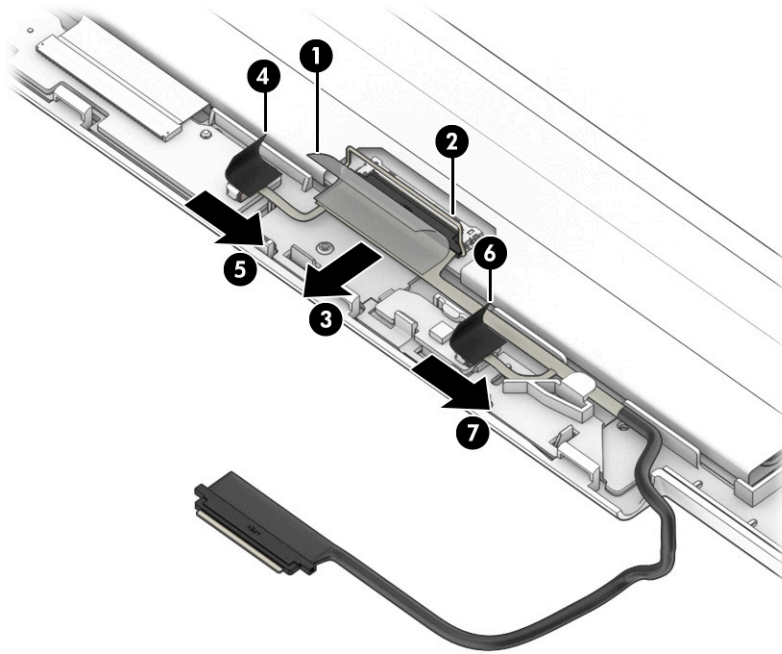

- h.** Remove the display panel cable.

The display panel cable is available using spare part number L73313-001.

- 14.** If it is necessary to replace the webcam/microphone module:

- a.** Remove the display panel assembly.
- b.** Detach the webcam/microphone module (1) from the display back cover. (The webcam/microphone module is attached to the display back cover with double-sided adhesive.)

- c. Release the ZIF connector **(2)** to which the webcam/microphone module cable is connected, and then disconnect the webcam/microphone module cable from the webcam/microphone module.

The webcam/microphone module is available using spare part number L73302-001.

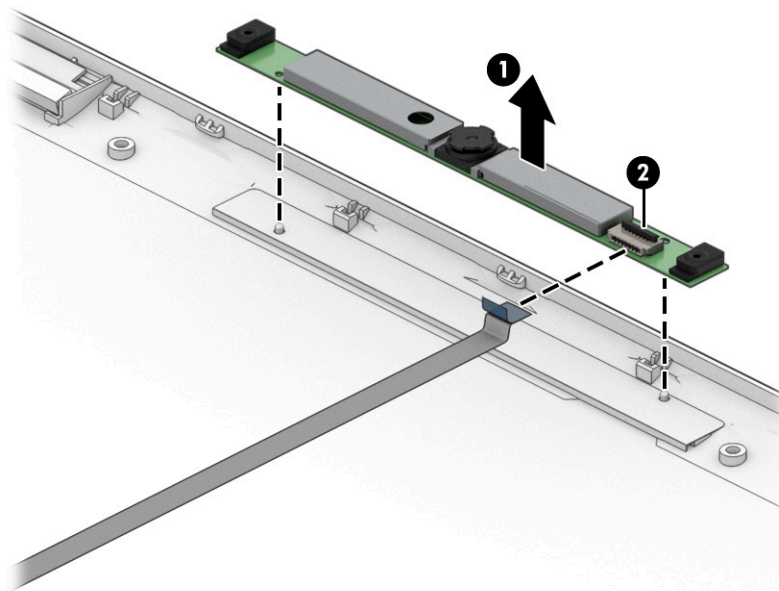

15. If it is necessary to replace the webcam/microphone module cable:

- a. Remove the display panel assembly.
- b. Release the ZIF connector **(1)** to which the webcam/microphone module cable is connected, and then disconnect the webcam/microphone module cable from the webcam/microphone module.
- c. Remove the hinge cap **(2)** from the display right hinge.
The hinge cap is available using spare part number L76602-001.
- d. Release the webcam/microphone module cable **(3)** from the display right hinge.

- e. Detach the webcam/microphone module **(4)** from the display back cover. (The webcam/microphone module is attached to the display back cover with double-sided adhesive.)

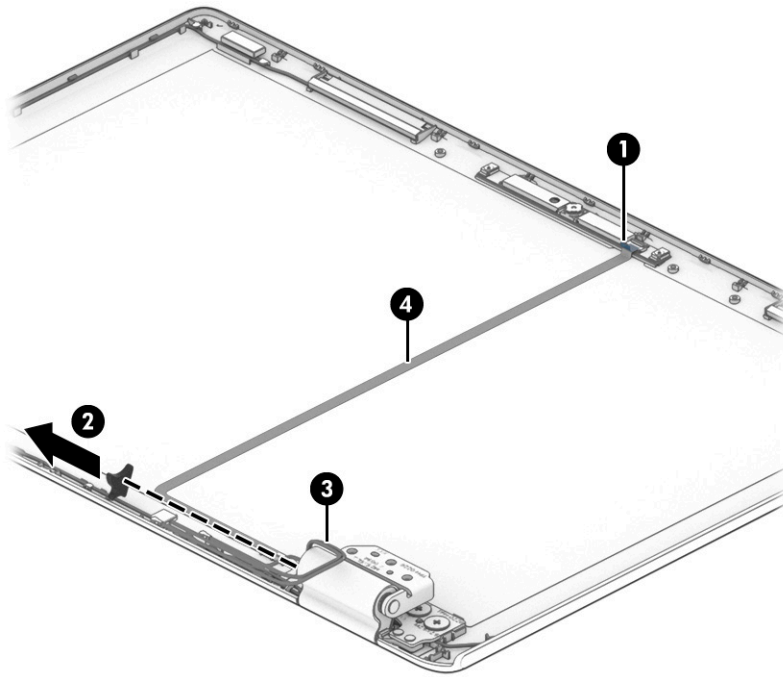

- f. Remove the webcam/microphone module cable.
The webcam/microphone module cable is available using spare part number L73314-001.

16. If it is necessary to replace the display hinges:

- a. Remove the display panel assembly.
- b. Remove the hinge cap **(1)** from the display right hinge.
The hinge cap is available using spare part number L76602-001.
- c. Release the webcam/microphone module cable **(2)** and wireless antenna cables from the display right hinge.
- d. Remove the six Phillips M2.2×3.0 broad head screws **(3)** that secure the display hinges to the display back cover.

- e. Remove the display hinges (4).

The display hinges are available using spare part number L73326-001.

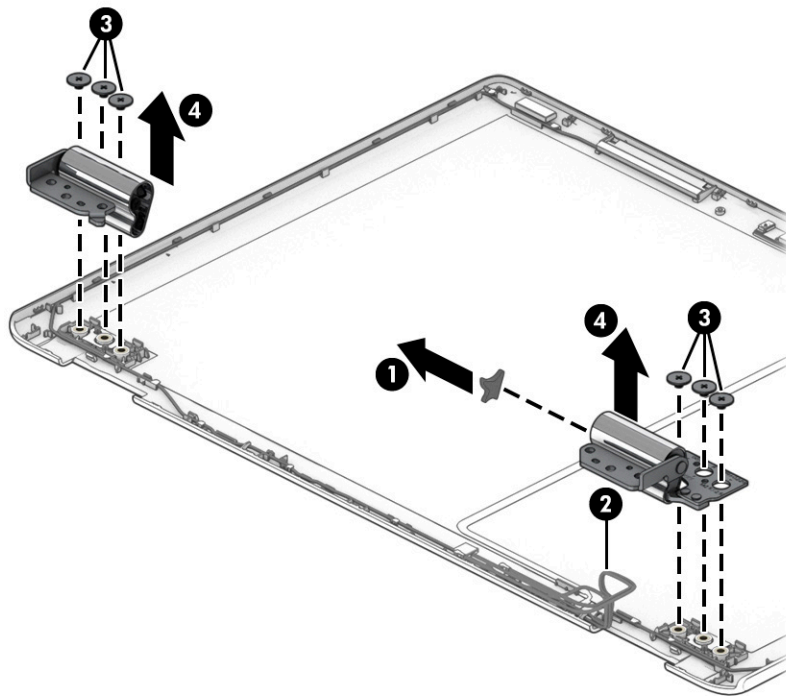

- 17. If it is necessary to replace the wireless antenna:

- a. Remove the display panel assembly.
- b. Remove the display hinges.
- c. Detach the wireless antenna transceivers (1) from the display back cover. (The wireless antenna transceivers are attached to the display back cover with double-sided adhesive.)
- d. Release the wireless antenna cables from the retention clips (2) and routing channels built into the top, left and right, and bottom edges of the display back cover

- e. Remove the wireless antenna cables (3) and transceivers.

The wireless antenna transceivers and cables are available using spare part number L73325-001.

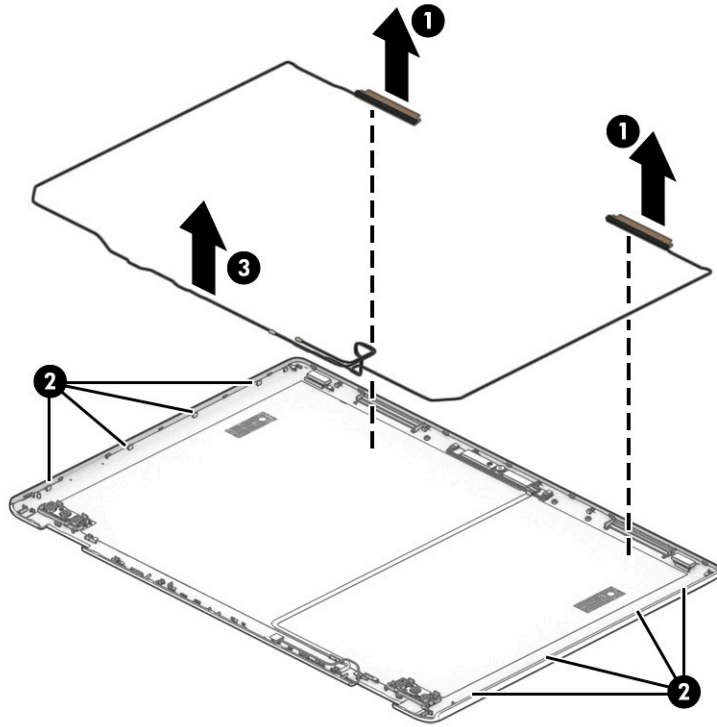

Reverse this procedure to reassemble and install the display assembly.

Touchpad cable

 **NOTE:** The touchpad cable is available using spare part number L73312-001.

Before removing the touchpad cable, follow these steps:

1. Shut down the computer. If you are unsure whether the computer is off or in Hibernation, turn the computer on, and then shut it down through the operating system.
2. Disconnect all external devices connected to the computer.
3. Disconnect the power from the computer by first unplugging the power cord from the AC outlet, and then unplugging the AC adapter from the computer.
4. Remove the bottom cover (see [Bottom cover on page 22](#)).
5. Remove the battery (see [Battery on page 24](#)).

Remove the touchpad cable:

1. Release the ZIF connector **(1)** to which touchpad cable is connected, and then disconnect the touchpad cable from the system board.
2. Release the ZIF connector **(2)** to which touchpad cable is connected, and then disconnect the touchpad cable from the touchpad.
3. Detach the touchpad cable **(3)** from the keyboard/top cover. (The touchpad cable is attached to the keyboard/top cover with adhesive.)

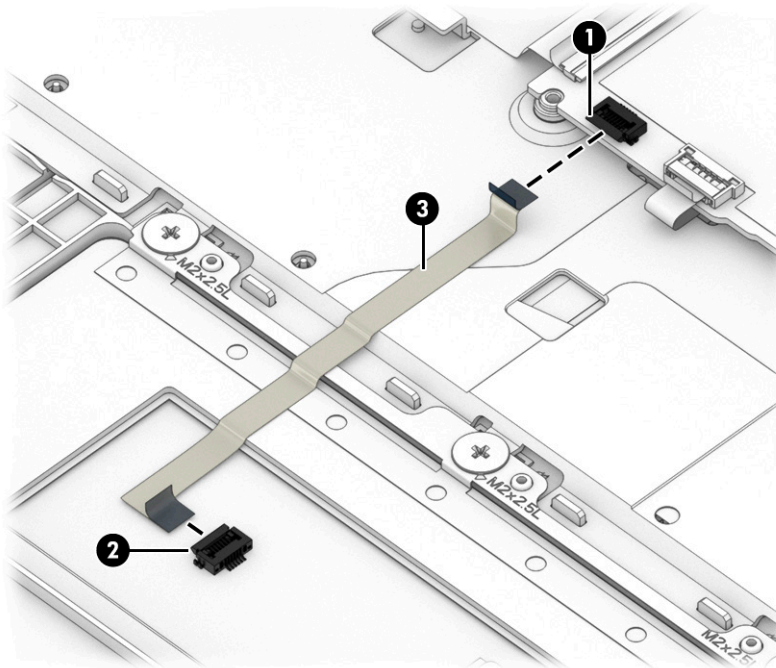

4. Remove the touchpad cable.

Reverse this procedure to install the touchpad cable.

Touchpad



NOTE: The touchpad spare part kit includes the touchpad bracket, but does not include the touchpad cable. The touchpad cable is available using spare part number L73312-001.

Table 5-8 Touchpad description and spare part number information

Description	Spare part number
In mineral silver finish	L73315-001
In natural silver finish	L73316-001

Before removing the touchpad, follow these steps:

1. Shut down the computer. If you are unsure whether the computer is off or in Hibernation, turn the computer on, and then shut it down through the operating system.
2. Disconnect all external devices connected to the computer.
3. Disconnect the power from the computer by first unplugging the power cord from the AC outlet, and then unplugging the AC adapter from the computer.
4. Remove the bottom cover (see [Bottom cover on page 22](#)).
5. Remove the battery (see [Battery on page 24](#)).

Remove the touchpad:

1. Release the ZIF connector **(1)** to which the touchpad cable is connected, and then disconnect the touchpad cable from the system board.
2. Detach the touchpad cable **(2)** from the keyboard/top cover. (The touchpad cable is attached to the keyboard/top cover with adhesive.)
3. Remove the three Phillips M2.0×2.7 broad head screws **(3)** that secure the touchpad to the keyboard/top cover.
4. Remove the three Phillips M2.0×2.9 screws **(4)** that secure the touchpad and bracket to the keyboard/top cover.
5. Remove the touchpad bracket **(5)**.

6. Remove the touchpad (6).

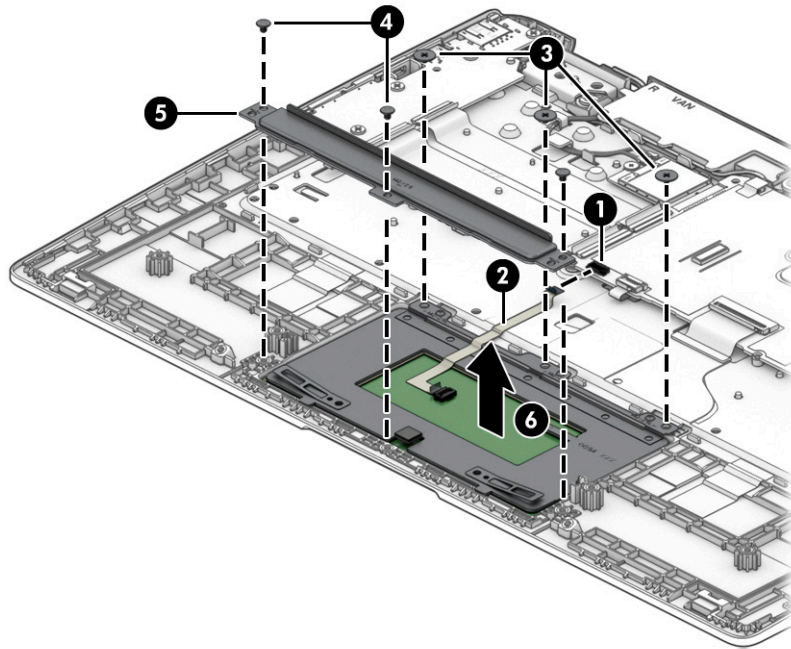

Reverse this procedure to install the touchpad and cable.

6 Specifications

Computer specifications

The power information in this section may be helpful if you plan to travel internationally with the computer.

The computer operates on DC power, which can be supplied by an AC or a DC power source. The AC power source must be rated at 100–240 V, 50–60 Hz. Although the computer can be powered from a standalone DC power source, it should be powered only with an AC adapter or a DC power source that is supplied and approved by HP for use with this computer.

The computer can operate on DC power within the following specifications. Operating voltage and current varies by platform. The voltage and current for your computer is located on the regulatory label.

Table 6-1 Computer specifications

	Metric	U.S.
Dimensions:		
Width	32.4 cm	12.8 in
Depth	22.6 cm	8.9 in
Height	1.9 cm	0.7 in
Weight	1.18 kg	2.6 lbs
Input power		
Operating voltage and current	5 V dc @ 2 A / 12 V dc @ 3 A / 15 V dc @ 3 A – 45 W USB-C	
	5 V dc @ 3 A / 9 V dc @ 3 A / 12 V dc @ 3.75 A / 15 V dc @ 3 A – 45 W USB-C	
	5 V dc @ 3 A / 9 V dc @ 3 A / 10 V dc @ 3.75 A / 12 V dc @ 3.75 A / 15 V dc @ 3 A / 20 V dc @ 2.25 A – 45 W USB-C	
	5 V dc @ 3 A / 9 V dc @ 3 A / 12 V dc @ 5 A / 15 V dc @ 4.33 A / 20 V dc @ 3.25 A – 65 W USB-C	
	5 V dc @ 3 A / 9 V dc @ 3 A / 10 V dc @ 5 A / 12 V dc @ 5 A / 15 V dc @ 4.33 A / 20 V dc @ 3.25 A – 65 W USB-C	
	5 V dc @ 3 A / 9 V dc @ 3 A / 10 V dc @ 5 A / 12 V dc @ 5 A / 15 V dc @ 5 A / 20 V dc @ 4.5 A – 90 W USB-C	
	19.5 V dc @ 2.31 A – 45 W	
	19.5 V dc @ 3.33 A – 65 W	
	19.5 V dc @ 4.62 A – 90 W	
	19.5 V dc @ 6.15 A – 120 W	
	19.5 V dc @ 6.9 A – 135 W	
	19.5 V dc @ 7.70 A – 150 W	
	19.5 V dc @ 10.3 A – 200 W	
19.5 V dc @ 11.8 A – 230 W		
19.5 V dc @ 16.92 A – 330 W		

Table 6-1 Computer specifications (continued)

	Metric	U.S.
Temperature		
Operating	5°C to 35°C	41°F to 95°F
Nonoperating	-20°C to 60°C	-4°F to 140°F
Relative humidity (noncondensing)		
Operating	10% to 90%	
Nonoperating	5% to 95%	
Maximum altitude (unpressurized)		
Operating	-15 m to 3,048 m	-50 ft to 10,000 ft
Nonoperating	-15 m to 12,192 m	-50 ft to 40,000 ft
NOTE: Applicable product safety standards specify thermal limits for plastic surfaces. The device operates well within this range of temperatures.		

7 Backing up, resetting, and recovering

Backing up

You can back up data to an optional USB flash drive or SD memory card or through Google Drive™. For detailed information about creating a backup, go to <http://www.support.google.com>.

Resetting

A factory reset erases all the information on the computer, including all the files in the Downloads folder. Before resetting the computer, make sure to back up all files to an optional USB flash drive, SD memory card, or through Google Drive. The factory reset will not delete any files on Google Drive or an external storage device.

 **IMPORTANT:** Resetting permanently erases everything on the computer, including downloaded files. If possible, back up all files before resetting the computer.

You might want to reset the computer in the following circumstances:

- You see the message "Reset this Chrome device."
- You are having problems with your user profile or settings.
- You have tried restarting your computer, and it's still not working properly.
- You want to change the owner of your computer.

To reset your computer:

1. Under the **Settings** menu, click **Advanced**.
2. In the **Powerwash** section, click **Powerwash**.
3. Click **Restart**, and then sign in with your Google account.

 **NOTE:** The account you sign in with after you reset your computer will be recognized as the owner account.

4. Follow the on-screen instructions to reset your computer.
5. After you complete the reset, you can set up your computer and check to see whether the problem is fixed.

Recovering

When your Chrome operating system (OS) isn't working properly, you can perform a recovery. A recovery reinstalls the operating system and software programs and restores the original factory settings. Locally saved files and saved networks are deleted for all accounts. Your Google accounts and any data synced to your Google Drive are not affected by a system recovery.

 **IMPORTANT:** Recovery permanently erases everything on the computer, including downloaded files. If possible, back up all files before recovering the computer.

 **NOTE:** For more information about performing a system recovery on your computer, go to <http://www.support.google.com>.

Before beginning the recovery process, you need the following:

- A USB flash drive or SD memory card with a capacity of 4 GB or greater. Because all data is erased from this storage device when the recovery media is created, back up any files from the device before you begin.
- A computer with Internet access. You must also have administrative rights to the computer.
- Computer AC adapter. The computer must be plugged into AC power during recovery.
- The “Chrome OS is missing or damaged” screen displaying on your computer. If this message is not already displayed:
 - Turn on the computer, press and hold the `esc+f3` keys, and then press the power button. The computer restarts, and the screen shows the “Chrome OS is missing or damaged” screen.

Installing the Chromebook Recovery Utility

The Chromebook Recovery Utility is an app used to recover the original operating system and software programs that were installed at the factory. This utility can be installed from the Chrome Web Store on any computer.

To install the Chromebook Recovery Utility:

- ▲ Open the Chrome Web Store, search for `chrome recovery`, click **Chromebook Recovery Utility** from the Apps list, and follow the on-screen instructions.

Creating recovery media

Recovery media is used to recover the original operating system and software programs that were installed at the factory.

To create recovery media:

1. Turn on a computer that has Internet access.
-
2. Click the **Launcher** icon, and then click **All Apps**.
 3. In the Apps window, click **Recovery**, and then click **Get started**.
 4. Follow the on-screen instructions to create the recovery media.

 **NOTE:** All data and partitions on the recovery media will be deleted. Do not remove the USB flash drive or SD memory card until the process is complete.

Recovering the Chrome operating system

To recover the Chrome operating system on your computer using the recovery media you created:

1. Disconnect any external devices connected to the computer, plug in the power cord, and then turn on the computer.
2. To enter recovery mode, press and hold **esc+f3**, and then press the power button. When the “Chrome OS is missing or damaged” screen displays, insert the recovery media into the computer. The recovery process begins immediately.
3. Wait while Chrome verifies the integrity of the recovery media.



NOTE: If you need to cancel the recovery during the verification process, press and hold the power button until the computer turns off. Do not disrupt the system recovery process after the verification step is complete.



NOTE: If an error message appears, you might need to run the Chrome Recovery Utility again, or use a different USB flash drive or SD memory card.

4. When the “System Recovery is complete” message appears, remove the recovery media.
The computer restarts with Chrome OS reinstalled.

Setting up the computer after a reset or recovery

After a reset or recovery is complete, perform the initial setup process. For details on setting up the computer, go to <http://www.support.google.com>.

Erase and format the recovery media

During the process of creating recovery media, the USB flash drive or SD memory card is formatted for use as a recovery tool. After you recover your computer, you will need to erase the recovery media if you want to reuse your USB flash drive or SD memory card to store other files. Use the steps in this section to erase the recovery media using the Chromebook Recovery Utility.

1. Click the **Launcher** icon, and then click **All Apps**.
2. In the apps window, click **Recovery**.
3. Click the **Settings** icon, and then click **Erase recovery media**.
4. Select the USB flash drive or SD memory card you inserted, click **Continue**, and then click **Erase now**.
5. After the recovery media is erased, click **Done** to close the Chromebook Recovery Utility, and then remove the USB flash drive or SD memory card.

The media is ready to be formatted with a formatting tool provided by your operating system.

8 Power cord set requirements

The wide-range input feature of the computer permits it to operate from any line voltage from 100 to 120 V AC, or from 220 to 240 V AC.

The 3-conductor power cord set included with the computer meets the requirements for use in the country or region where the equipment is purchased.

Power cord sets for use in other countries or regions must meet the requirements of the country and region where the computer is used.

Requirements for all countries

The following requirements are applicable to all countries and regions:

- The length of the power cord set must be at least **1.0 m** (3.3 ft) and no more than **2.0 m** (6.5 ft).
- All power cord sets must be approved by an acceptable accredited agency responsible for evaluation in the country or region where the power cord set will be used.
- The power cord sets must have a minimum current capacity of 10 A and a nominal voltage rating of 125 or 250 V AC, as required by the power system of each country or region.
- The appliance coupler must meet the mechanical configuration of an EN 60 320/IEC 320 Standard Sheet C13 connector for mating with the appliance inlet on the back of the computer.

Requirements for specific countries and regions

Table 8-1 Power cord requirements

Country/region	Accredited agency	Applicable note number
Argentina	IRAM	1
Australia	SAA	1
Austria	OVE	1
Belgium	CEBEC	1
Brazil	ABNT	1
Canada	CSA	2
Chile	IMQ	1
Denmark	DEMKO	1
Finland	FIMKO	1
France	UTE	1
Germany	VDE	1
India	BIS	1
Israel	SII	1
Italy	IMQ	1
Japan	JIS	3
The Netherlands	KEMA	1
New Zealand	SANZ	1
Norway	NEMKO	1
The People's Republic of China	CCC	4
Saudi Arabia	SASO	7
Singapore	PSB	1
South Africa	SABS	1
South Korea	KTL	5
Sweden	SEMKO	1
Switzerland	SEV	1
Taiwan	BSMI	6
Thailand	TISI	1
The United Kingdom	ASTA	1
The United States	UL	2

1. The flexible cord must be Type H05VV-F, 3-conductor, 0.75 mm² conductor size. Power cord set fittings (appliance coupler and wall plug) must bear the certification mark of the agency responsible for evaluation in the country or region where it will be used.

Table 8-1 Power cord requirements (continued)

Country/region	Accredited agency	Applicable note number
		2. The flexible cord must be Type SVT/SJT or equivalent, No. 18 AWG, 3-conductor. The wall plug must be a two-pole grounding type with a NEMA 5-15P (15 A, 125 V AC) or NEMA 6-15P (15 A, 250 V AC) configuration. CSA or C-UL mark. UL file number must be on each element.
		3. The appliance coupler, flexible cord, and wall plug must bear a "T" mark and registration number in accordance with the Japanese Dentori Law. The flexible cord must be Type VCTF, 3-conductor, 0.75 mm ² or 1.25 mm ² conductor size. The wall plug must be a two-pole grounding type with a Japanese Industrial Standard C8303 (7 A, 125 V AC) configuration.
		4. The flexible cord must be Type RVV, 3-conductor, 0.75 mm ² conductor size. Power cord set fittings (appliance coupler and wall plug) must bear the CCC certification mark.
		5. The flexible cord must be Type H05VV-F 3-conductor, 0.75 mm ² conductor size. KTL logo and individual approval number must be on each element. Corset approval number and logo must be printed on a flag label.
		6. The flexible cord must be Type HVCTF 3-conductor, 1.25 mm ² conductor size. Power cord set fittings (appliance coupler, cable, and wall plug) must bear the BSMI certification mark.
		7. For 127 V AC, the flexible cord must be Type SVT or SJT 3-conductor, 18 AWG, with plug NEMA 5-15P (15 A, 125 V AC), with UL and CSA or C-UL marks. For 240 V AC, the flexible cord must be Type H05VV-F 3-conductor, 0.75 mm ² or 1.00 mm ² conductor size, with plug BS 1363/A with BSI or ASTA marks.

9 Recycling

When a non-rechargeable or rechargeable battery has reached the end of its useful life, do not dispose of the battery in general household waste. Follow the local laws and regulations in your area for battery disposal.

HP encourages customers to recycle used electronic hardware, HP original print cartridges, and rechargeable batteries. For more information about recycling programs, see the HP Web site at <http://www.hp.com/recycle>.

Index

A

AC adapter and battery light 3, 4
AC adapter, spare part number 16
action keys 9
antenna
 locations 6
 removal 45
 spare part number 16, 46
audio, product description 1
audio-in jack 4
audio-out jack 4

B

battery
 removal 24
 spare part number 14, 24
battery bracket, spare part number 14, 24
bottom cover
 removal 22
 spare part numbers 14, 22
buttons
 left touchpad 7
 power 5
 right touchpad 7
 volume 3

C

camera 6
camera light 6
chipset, product description 1
components
 display 6
 keyboard area 7
 left side 4
 right side 3
 speakers 8
 special keys 9
computer foot
 removal 22
 spare part numbers 14, 22
computer major components 11
computer specifications 50

D

display assembly
 removal 36
 spare part number 36
display back cover, spare part number 16
display components 6, 15
display panel assembly
 removal 38
 spare part numbers 15, 39
display panel cable
 removal 41
 spare part number 15, 42
display panel, product description 1

E

electrostatic discharge 18
equipment guidelines 20
esc key 9
external media card, product description 1

F

foot
 removal 22
 spare part numbers 14, 22

G

G-sensor board
 removal 40
 spare part number 15, 41
graphics, product description 1
grounding guidelines 18
guidelines
 equipment 20
 grounding 18
 packaging 19
 transporting 19
 workstation 20

H

headphone jack 4
hinge
 removal 44
 spare part number 15, 45

hinge cap
 removal 38, 43, 44
 spare part number 15, 38, 43, 44

I

internal microphones 6

J

jacks
 audio-in 4
 audio-out 4
 headphone 4
 microphone 4

K

keyboard, product description 1, 2
keyboard/top cover, spare part numbers 11, 12
keys
 action 9
 esc 9

L

labels 9
left side components 4
lights
 AC adapter and battery light 3, 4
 camera 6
 power 5

M

magnetic stylus docking 5
memory, product description 1
microphone
 location 6
 product description 1
microphone jack 4
microSD memory card reader 5
model name 1
mouse, spare part numbers 16

O

operating system, product description 2

- P**
- packaging guidelines 19
- pen, spare part number 16
- ports
 - product description 1
 - USB SuperSpeed port with HP Sleep and Charge 4
 - USB Type-C power connector and port 3, 4, 5
- power button 5
- power cable
 - removal 34
 - spare part number 14, 34
- power cord
 - requirements for all countries 55
 - requirements for specific countries and regions 56
 - set requirements 55
 - spare part numbers 16
- power light 5
- power requirements, product description 2
- processor, product description 1
- product description
 - audio 1
 - chipset 1
 - display panel 1
 - external media card 1
 - graphics 1
 - keyboard 1, 2
 - memory 1
 - microphone 1
 - operating system 2
 - ports 1
 - power requirements 2
 - processors 1
 - product name 1
 - security 2
 - solid-state drive 1
 - storage 1
 - video 1
 - wireless 1
- product name 1

- R**
- right side components 3
- Rubber Feet Kit, spare part number 14
- Rubber Feet Kit, spare part numbers 22

- rubber foot
 - spare part numbers 14

- S**
- screw cover
 - removal 23
 - spare part numbers 14, 23
- Screw Cover Kit, spare part numbers 14, 23
- Screw Kit, spare part number 16
- security cable slot 3
- security, product description 2
- service labels 9
- sleeve, spare part number 16
- solid-state drive
 - product description 1
- Speaker Kit, spare part number 13
- speakers
 - components 8
 - removal 35
 - spare part number 13, 35
- special keys 9
- specifications 50
- system board
 - removal 30
 - spare part numbers 13, 30

- T**
- Thermal Pad Replacement Kit, spare part number 14, 30, 33
- touch control board
 - removal 39
 - spare part numbers 15, 40
- touchpad
 - removal 48
 - spare part numbers 14, 48
- touchpad buttons 7
- touchpad cable
 - removal 47
 - spare part number 14, 47, 48
- touchpad zone 7
- transporting guidelines 19

- U**
- USB SuperSpeed port with HP Sleep and Charge 4
- USB Type-C power connector and port 3, 4, 5
- USB/audio board
 - removal 29
 - spare part number 14, 29
- USB/audio board cable
 - removal 28
 - spare part number 28
- USB/audio board high-power cable
 - removal 28
 - spare part number 14, 28, 29
- USB/audio board low-power cable
 - removal 28
 - spare part number 14, 28, 29

- V**
- video, product description 1
- volume button 3

- W**
- webcam/microphone module
 - removal 42
 - spare part number 15, 43
- webcam/microphone module cable
 - removal 43
 - spare part number 16, 44
- wireless antenna
 - locations 6
 - removal 45
 - spare part number 16, 46
- wireless, product description 1
- WLAN antenna
 - locations 6
 - removal 45
 - spare part number 16, 46
- WLAN module
 - removal 26
 - spare part number 13, 26
- workstation guidelines 20