



Maintenance and Service Guide

HP 340 G7 Notebook PC
HP 348 G7 Notebook PC

IMPORTANT! This document is intended for HP authorized service providers only.

© Copyright 2019 HP Development Company, L.P.

AMD and Radeon are trademarks of Advanced Micro Devices, Inc. Bluetooth is a trademark owned by its proprietor and used by HP Inc. under license. Intel, Core, Optane, and Thunderbolt are trademarks of Intel Corporation or its subsidiaries in the U.S. and/or other countries. SDHC, SDXC, and microSD are trademarks or registered trademarks of SD-3C LLC. Microsoft and Windows are either a registered trademarks or trademarks of Microsoft Corporation in the United States and/or other countries. Miracast is a registered trademark of Wi-Fi Alliance.

The information contained herein is subject to change without notice. The only warranties for HP products and services are set forth in the express warranty statements accompanying such products and services. Nothing herein should be construed as constituting an additional warranty. HP shall not be liable for technical or editorial errors or omissions contained herein.

First Edition: November 2019

Document Part Number: L66142-001

Product notice

This guide describes features that are common to most models. Some features may not be available on your computer.

Not all features are available in all editions or versions of Windows. Systems may require upgraded and/or separately purchased hardware, drivers, software or BIOS update to take full advantage of Windows functionality. Windows 10 is automatically updated, which is always enabled. ISP fees may apply and additional requirements may apply over time for updates. Go to <http://www.microsoft.com> for details.

To access the latest user guides, go to <http://www.hp.com/support>, and follow the instructions to find your product. Then select **User Guides**.

Software terms

By installing, copying, downloading, or otherwise using any software product preinstalled on this computer, you agree to be bound by the terms of the HP End User License Agreement (EULA). If you do not accept these license terms, your sole remedy is to return the entire unused product (hardware and software) within 14 days for a full refund subject to the refund policy of your seller.

For any further information or to request a full refund of the price of the computer, please contact your seller.

Safety warning notice

 **WARNING!** To reduce the possibility of heat-related injuries or of overheating the computer, do not place the computer directly on your lap or obstruct the computer air vents. Use the computer only on a hard, flat surface. Do not allow another hard surface, such as an adjoining optional printer, or a soft surface, such as pillows or rugs or clothing, to block airflow. Also, do not allow the AC adapter to come into contact with the skin or a soft surface, such as pillows or rugs or clothing, during operation. The computer and the AC adapter comply with the user-accessible surface temperature limits defined by applicable safety standards.

Table of contents

1 Product description	1
2 Getting to know your computer	5
Right side	5
Left side	6
Display	7
Low blue light mode (select products only)	7
Keyboard area	8
Touchpad	8
Touchpad settings	8
Lights	9
Button, vent, speakers, and fingerprint reader	10
Special keys	11
Bottom	12
Labels	13
3 Illustrated parts catalog	15
Computer major components	15
Display assembly subcomponents	18
Miscellaneous parts	19
4 Removal and replacement procedures preliminary requirements	21
Tools required	21
Service considerations	21
Plastic parts	21
Cables and connectors	21
Drive handling	22
Workstation guidelines	22
Electrostatic discharge information	22
Generating static electricity	23
Preventing electrostatic damage to equipment	23
Personal grounding methods and equipment	24
Grounding the work area	24
Recommended materials and equipment	24
Packaging and transporting guidelines	25

5 Removal and replacement procedures for authorized service provider parts	27
Component replacement procedures	27
Preparation for disassembly	27
Computer feet	27
Bottom cover	29
Battery	31
Hard drive	32
WLAN module	34
Memory module	36
Solid-state drive	37
Speakers	38
Fingerprint sensor	39
Power connector	40
Touchpad click board	41
Touchpad	42
USB board	43
Fan	44
System board	45
Heat sink assembly	48
Display assembly	51
Top cover/keyboard	58
6 Computer Setup (BIOS), TPM, and HP Sure Start	59
Using Computer Setup	59
Starting Computer Setup	59
Navigating and selecting in Computer Setup	59
Restoring factory settings in Computer Setup	59
Updating the BIOS	60
Determining the BIOS version	60
Downloading a BIOS update	60
Changing the boot order using the f9 prompt	61
TPM BIOS settings (select products only)	61
Using HP Sure Start (select products only)	62
7 Backing up, restoring, and recovering	63
Backing up information and creating recovery media	63
Using Windows tools	63
Using the HP Cloud Recovery Download Tool to create recovery media (select products only)	63
Restoring and recovery	64
Restoring, resetting, and refreshing using Windows tools	64

Recovering using HP Recovery media	64
Changing the computer boot order	64
Using HP Sure Recover (select products only)	65
8 Using HP PC Hardware Diagnostics	67
Using HP PC Hardware Diagnostics Windows (select products only)	67
Downloading HP PC Hardware Diagnostics Windows	67
Downloading the latest HP PC Hardware Diagnostics Windows version	68
Downloading HP Hardware Diagnostics Windows by product name or number (select products only)	68
Installing HP PC Hardware Diagnostics Windows	68
Using HP PC Hardware Diagnostics UEFI	68
Starting HP PC Hardware Diagnostics UEFI	69
Downloading HP PC Hardware Diagnostics UEFI to a USB flash drive	69
Downloading the latest HP PC Hardware Diagnostics UEFI version	69
Downloading HP PC Hardware Diagnostics UEFI by product name or number (select products only)	70
Using Remote HP PC Hardware Diagnostics UEFI settings (select products only)	70
Downloading Remote HP PC Hardware Diagnostics UEFI	70
Downloading the latest Remote HP PC Hardware Diagnostics UEFI version	70
Downloading Remote HP PC Hardware Diagnostics UEFI by product name or number	70
Customizing Remote HP PC Hardware Diagnostics UEFI settings	70
9 Specifications	73
Computer specifications	73
35.6 cm (14.0 in) display specifications	74
Hard drive specifications	75
PCIe solid-state drive specifications	76
SATA solid-state drive specifications	77
10 Power cord set requirements	79
Requirements for all countries	79
Requirements for specific countries and regions	80
11 Statement of memory volatility	83
Nonvolatile memory usage	85
Questions and answers	88
Using HP Sure Start (select models only)	89

12 Recycling	91
Index	93

1 Product description

Category	Description
Product Name	HP 340 G7 Notebook PC
	HP 348 G7 Notebook PC
Processor	10th-generation Intel® Core™ processors
	i7-10510U (1.8 GHz/4.9 GHz, quad core processor (8 MB L3 cache, 15 W; Intel UHD Graphics)
	i5-10210U (1.6 GHz/4.2 GHz, quad core processor (6 MB L3 cache, 15 W; Intel UHD Graphics)
	i3-10110U (2.1 GHz/4.1 GHz, dual core processor (4 MB L3 cache, 15 W; Intel UHD Graphics)
	8th-generation Intel Core processors
	i3-8130U (2.2 GHz/3.4 GHz, dual core processor, 4 MB L3 cache, 15 W; Intel UHD Graphics 620)
Graphics	7th generation Intel Core processors
	i3-7020U (2.3 GHz dual core processor, 3 MB L3 cache, 15 W; Intel HD Graphics 620)
	Internal graphics
	Intel UHD Graphics (10th generation Intel processors)
	Intel UHD Graphics 620 (8th generation Intel processors)
	Intel HD Graphics 620 (7th generation Intel processors)
	Switchable discrete graphics
	Supports HD decode, DX12, and HDMI
	Supports MR graphics (requires Core i7/Core i5 processors, at least 8 GB system memory, > 10 GB free hard drive space, Windows® Display Driver Model 2.2, HDMI 1.4 display)
	AMD® Radeon™ 530 with 2 GB of dedicated video memory
Panel	35.6 cm (14.0 in), WLED, antiglare, eDP, 45% CG, slim-flat (3.0 mm), 16:9 ultrawide aspect ratio, narrow bezel, nontouch
	High definition (HD) (1366 × 768), SVA, 220 nits, 1 or 2 WLAN antennas
	Full high-definition (FHD) (1920 × 1080), UWVA, 250 nits, 1 or 2 WLAN antennas
Memory	Two memory module slots
	Memory is customer accessible/nonupgradeable
	DDR4-2666 (10th generation processors)
	DDR4-2666 downgrade to DDR4-2133 (7th and 8th generation processors)
	Supports up to 32 GB of system RAM in the following configurations:
	<ul style="list-style-type: none">32 GB (16 GB × 2) (dual channel)16 GB (16 GB × 1)8 GB (8 GB × 1)

Category	Description
	<ul style="list-style-type: none"> 4 GB (4 GB × 1)
Primary storage	<p>Hard drive, SATA, 7 mm, 2.5 in (not required if M.2 drive selected)</p> <p>1 TB, 5400 rpm</p> <p>500 GB, 7200 rpm</p> <p>M.2 2280 solid-state drive (NGFF) (supports DriveLock)</p> <p>512 GB, PCIe, NVMe, value</p> <p>256 GB, PCIe, NVMe, TLC</p> <p>256 GB, PCIe, NVMe, value</p> <p>128 GB, SATA, TLC</p>
Cache memory	Intel Optane™ 16 GB memory cache (not available in models with M.2 solid-state drive (SSD) primary storage)
Camera	<p>HP TrueVision HD Camera – indicator LED, USB 2.0, HD BSI sensor, f2.0, WDR (select models only)</p> <p>720p by 30 frames per second</p> <p>Dual array microphone</p>
Audio	Stereo speakers (2)
RJ-45 (network) jack	<p>Realtek RTL8111HSH-CG Gigabit Ethernet controller</p> <p>S3/S4/S5 wake on LAN (both AC power and battery modes)</p> <p>BIOS Support RTXMAC for MAPT via in band</p> <p>The following support S3 wake on LAN (via out of band): HP USB-C Dock G5, HP USB-C/A Universal Dock G2, HP USB-C Universal Dock, HP USB-C Dock G4, HP Thunderbolt Dock 120 W G2, and HP USB-C Mini Dock.</p> <p>The following support S0/S3/S4/S5 HBMA (via out of band): HP USB-C Dock G5, HP USB-C/A Universal Dock G2, HP USB-C Universal Dock, HP USB-C Dock G4, HP Thunderbolt Dock 120 W G2, and HP USB-C Mini Dock.</p>
Wireless networking	<p>Wireless Personal Area Network (PAN) Bluetooth®</p> <p>Bluetooth support using combo card</p> <p>Wireless Local Area Network (WLAN) (select products only)</p> <p>Compatible with Wi-Fi CERTIFIED Miracast™ devices</p> <p>HP Connection Optimizer with data analytics</p> <p>Support for HP LAN-Wireless Protection (WLAN/LAN/WWAN switching)</p> <p>Support for WoWLAN S3</p> <p>Integrated wireless options with dual antennas (M.2 2230 socket MIPI/BRI)</p> <p>Intel® Wireless-AC 9560 802.11ac 2 × 2 Wi-Fi + Bluetooth 5 (non-vPro, supporting gigabit file transfer speeds)</p> <p>Intel Wi-Fi 6 AX201, 802.11ax 2 × 2 + Bluetooth 5 (non-vPro, supporting gigabit file transfer speeds)</p> <p>Integrated wireless options with dual antennas (M.2 2230 socket MIPI/USB)</p> <p>Realtek RTL8822CE 802.11ac 2 × 2 Wi-Fi + Bluetooth 5.0</p> <p>Integrated wireless options with single antennas (M.2 2230 socket MIPI/USB)</p> <p>Realtek RTL8821CE 802.11ac 1 × 1 Wi-Fi + Bluetooth 4.2</p>

Category	Description
Media card reader	Supports microSD™/SDHC™/SDXC™ Push-pull insertion/removal
Internal card expansion	One M.2 slot for solid-state drive/Optane memory module One M.2 slot for WLAN
Ports	Hot plug/unplug and autodetect for correct output to wide-aspect vs. standard aspect video (autoadjust panel resolution to fit embedded panel and external monitor connected) HDMI v1.4 supporting: up to 1920 × 1080 @ 60 Hz USB Type-C 3.1 Gen 1 port (data transfer only; left side) (2) USB Type-A 3.1 Gen 1 ports (right side) RJ-45 (network) Audio-out (headphone)/Audio-in (microphone) combo jack AC Smart Pin adapter plug
Keyboard/pointing devices	Keyboard Full-size, spill-resistant, island-style keyboard No numeric keypad Touchpad Multitouch gestures enabled Taps enabled by default
Power requirements	Battery 3 cell, 41 Whr, prismatic/polymer, long-life Supports battery fast charge, 90 min/90% charge (with 65 W AC adapter in S3/S4/S5) or 45 min/50% charge AC adapter, standard barrel 65 W Smart (models with discrete graphics) 65 W Smart, EM (only for Asia, People's Republic of China, and India) 45 W Smart (models with UMA graphics) Power cord (C5) 3-wire plug (with ground pin), 1.8 m (5.9 ft) 3-wire plug (with ground pin), 1.0 m (3.3 ft)
Security	Mini security slot Fingerprint sensor (select products only) Supports firmware-based Trusted Platform Module (fTPM) 2.0
Operating system	FreeDOS 3.0 Windows 10 Home 64 Windows 10 Home 64 Advanced Windows 10 Home 64 Advanced Single Language

Category	Description
	Windows 10 Home 64 Chinese Market CPPP
	Windows 10 Home 64 High-end Chinese Market CPPP
	Windows 10 Home 64 Plus
	Windows 10 Home 64 Plus Single Language
	Windows 10 Home 64 Plus Single Language APAC EM PPP
	Windows 10 Home 64 Plus Single Language India Market PPP
	Windows 10 Home 64 Plus Single Language Indonesia Market PPP
	Windows 10 Pro 64
	Windows 10 Pro 64 Chinese Market
	Windows 10 Pro 64 StF MSNA Plus
	Windows 10 Pro 64 StF MSNA Standard
	Windows 10 Pro 64 StF MSNA Strategic
	Restore media
	SSRD (System Recovery Disc)
	Web-only support
	Windows 10 Enterprise
	Tested and documented
	Windows 10 Enterprise 64 LTSC 1809
Serviceability	User replaceable part
	AC adapter

2 Getting to know your computer

Your computer features top-rated components. This chapter provides details about your components, where they are located, and how they work.

Right side

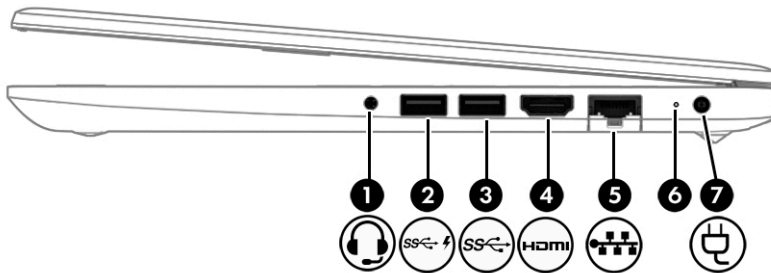

Table 2-1 Right-side components and their descriptions





Component	Description
<p>(1)  Audio-out (headphone)/Audio-in (microphone) combo jack</p>	<p>Connects optional powered stereo speakers, headphones, earbuds, a headset, or a television audio cable. Also connects an optional headset microphone. This jack does not support optional standalone microphones.</p> <p>WARNING! To reduce the risk of personal injury, adjust the volume before putting on headphones, earbuds, or a headset. For additional safety information, see the <i>Regulatory, Safety, and Environmental Notices</i>.</p> <p>To access this guide:</p> <ul style="list-style-type: none"> ▲ Type HP Documentation in the taskbar search box, and then select HP Documentation. <p>NOTE: When a device is connected to the jack, the computer speakers are disabled.</p>
<p>(2)  USB SuperSpeed port with HP Sleep and Charge</p>	<p>Connects a USB device, provides high-speed data transfer, and even when the computer is off, charges most products such as a cell phone, camera, activity tracker, or smartwatch.</p>
<p>(3)  USB SuperSpeed port</p>	<p>Connects a USB device, such as a cell phone, camera, activity tracker, or smartwatch, and provides high-speed data transfer.</p>
<p>(4)  HDMI port</p>	<p>Connects an optional video or audio device, such as a high-definition television, any compatible digital or audio component, or a high-speed High-Definition Multimedia Interface (HDMI) device.</p>
<p>(5)  RJ-45 (network) jack/status lights</p>	<p>Connects a network cable.</p> <ul style="list-style-type: none"> • White: The network is connected. • Amber: Activity is occurring on the network.
<p>(6) AC adapter and battery light</p>	<ul style="list-style-type: none"> • White: The AC adapter is connected and the battery is fully charged.

Table 2-1 Right-side components and their descriptions (continued)

Component	Description
(7)	Power connector
	<ul style="list-style-type: none"> Blinking white: The AC adapter is disconnected and the battery has reached a low battery level. Amber: The AC adapter is connected and the battery is charging. Off: The battery is not charging.
	Connects an AC adapter.

Left side

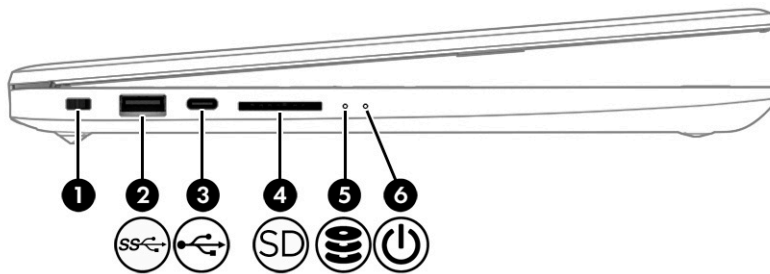

Table 2-2 Left-side components and their descriptions





Component	Description	
(1)	Security cable slot	
	Attaches an optional security cable to the computer.	
	NOTE: The security cable is designed to act as a deterrent, but it may not prevent the computer from being mishandled or stolen.	
(2)	 USB SuperSpeed port	Connects a USB device, such as a cell phone, camera, activity tracker, or smartwatch, and provides high-speed data transfer.
(3)	 USB Type-C port	Connects a USB device, such as a cell phone, camera, activity tracker, or smartwatch, and provides data transfer.
	NOTE: Cables, adapters, or both (purchased separately) may be required.	
(4)	 Memory card reader	Reads optional memory cards that enable you to store, manage, share, or access information. To insert a card: <ol style="list-style-type: none"> Hold the card label-side up, with connectors facing the computer. Insert the card into the memory card reader, and then press in on the card until it is firmly seated. To remove a card: <ul style="list-style-type: none"> ▲ Press in on the card, and then remove it from the memory card reader.
(5)	 Drive light (select products only)	<ul style="list-style-type: none"> Blinking white: The hard drive is being accessed.
(6)	 Power light	<ul style="list-style-type: none"> On: The computer is on.

Table 2-2 Left-side components and their descriptions (continued)

Component	Description
	<ul style="list-style-type: none">Blinking: (select products only): The computer is in the Sleep state, a power-saving state. The computer shuts off power to the display and other unnecessary components.Off: Depending on your computer model, the computer is off, in Hibernation, or in Sleep. Hibernation is the power-saving state that uses the least amount of power.

Display

Low blue light mode (select products only)

Your computer display is shipped from the factory in low blue light mode for improved eye comfort and safety. Also, blue light mode automatically adjusts blue light emissions when you are using the computer at night or for reading.

⚠ WARNING! To reduce the risk of serious injury, read the *Safety & Comfort Guide*. It describes proper workstation setup and proper posture, health, and work habits for computer users. The *Safety & Comfort Guide* also provides important electrical and mechanical safety information. The *Safety & Comfort Guide* is available on the web at <http://www.hp.com/ergo>.

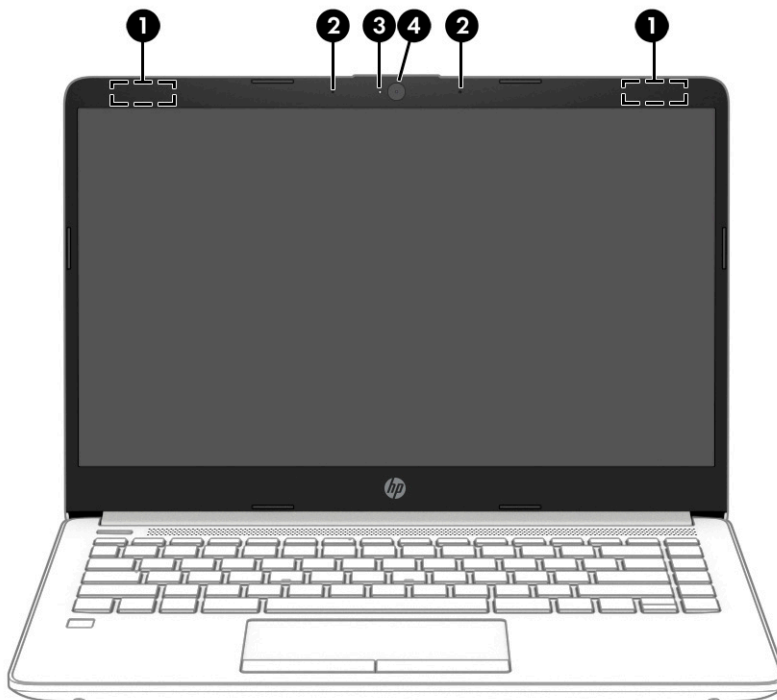

Table 2-3 Display components and their descriptions

Component	Description
(1) WLAN antennas* (select products only)	Send and receive wireless signals to communicate with wireless local area networks (WLANs).
(2) Internal microphones	Record sound.

Table 2-3 Display components and their descriptions (continued)

Component	Description
(3) Camera light (select products only)	On: The camera is in use.
(4) Camera (select products only)	Allows you to video chat, record video, and record still images. Some cameras also allow a facial recognition logon to Windows, instead of a password logon. NOTE: Camera functions vary depending on the camera hardware and software installed on your product.

*The antennas are not visible from the outside of the computer. For optimal transmission, keep the areas immediately around the antennas free from obstructions.

For wireless regulatory notices, see the section of the *Regulatory, Safety, and Environmental Notices* that applies to your country or region.

To access this guide:

- ▲ Type `HP Documentation` in the taskbar search box, and then select **HP Documentation**.

Keyboard area

Touchpad

Touchpad settings

To adjust touchpad settings and gestures, or to turn off the touchpad:

1. Type `touchpad settings` in the taskbar search box, and then press `enter`.
2. Choose a setting.

To turn on the touchpad:

1. Type `touchpad settings` in the taskbar search box, and then press `enter`.
2. Using an external mouse, click the **touchpad** button.

– or –

- ▲ Press the `tab` key repeatedly until the pointer rests on the **touchpad** button. Then press the `spacebar` to select the button.

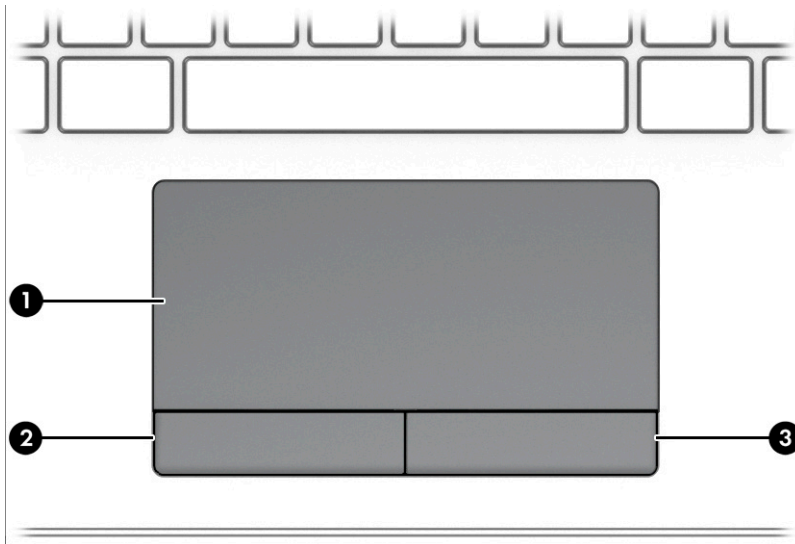

Table 2-4 Touchpad components and their descriptions

Component	Description
(1) Touchpad zone	Reads your finger gestures to move the pointer or activate items on the screen.
(2) Left touchpad button	Functions like the left button on an external mouse.
(3) Right touchpad button	Functions like the right button on an external mouse.

Lights

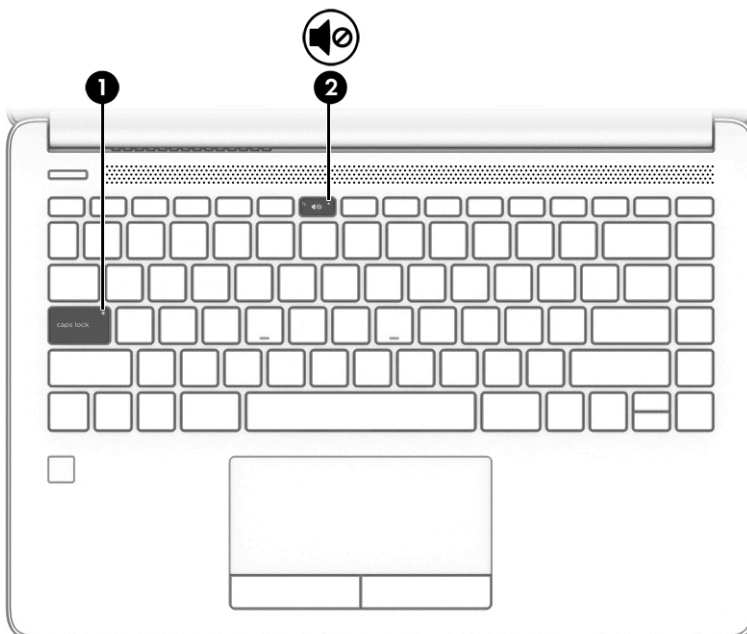

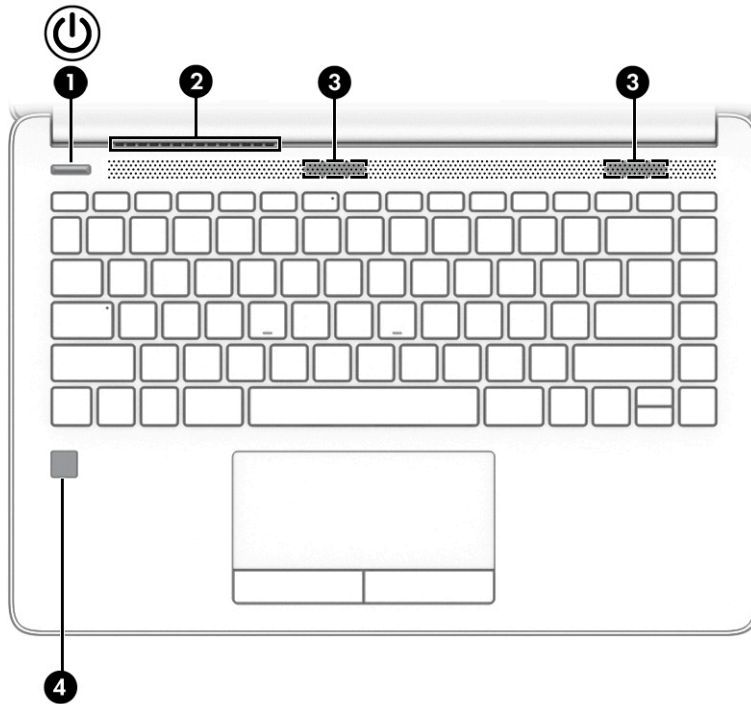

Table 2-5 Lights and their descriptions

Component	Description
(1) Caps lock light	On: Caps lock is on, which switches the key input to all capital letters.
(2)  Mute light	<ul style="list-style-type: none">On: Computer sound is off.Off: Computer sound is on.

Button, vent, speakers, and fingerprint reader



Fingerprint readers can be located on the touchpad, on a side panel of the computer, or on the top cover below the keyboard.

 **IMPORTANT:** To verify that your computer supports fingerprint reader sign-in, type *Sign-in options* in the taskbar search box and follow the on-screen instructions. If **Fingerprint reader** is not listed as an option, then your computer does not include a fingerprint reader.

Table 2-6 Button, vent, speakers, and fingerprint reader and their descriptions



Component	Description
(1)  Power button	<ul style="list-style-type: none">When the computer is off, press the button to turn on the computer.When the computer is on, press the button briefly to initiate Sleep.When the computer is in the Sleep state, press the button briefly to exit Sleep (select products only).When the computer is in Hibernation, press the button briefly to exit Hibernation. <p>IMPORTANT: Pressing and holding down the power button results in the loss of unsaved information.</p>

Table 2-6 Button, vent, speakers, and fingerprint reader and their descriptions (continued)

Component	Description
	<p>If the computer has stopped responding and shutdown procedures are ineffective, press and hold the power button down for at least 5 seconds to turn off the computer.</p> <p>To learn more about your power settings, see your power options:</p> <ul style="list-style-type: none"> ▲ Right-click the Power icon , and then select Power Options.
(2) Vent	<p>Enables airflow to cool internal components.</p> <p>NOTE: The computer fan starts up automatically to cool internal components and prevent overheating. It is normal for the internal fan to cycle on and off during routine operation.</p>
(3) Speakers (2)	Produce sound.
(4) Fingerprint reader (select products only)	<p>Allows a fingerprint logon to Windows, instead of a password logon.</p> <ul style="list-style-type: none"> ▲ Swipe down across the fingerprint reader. <p>IMPORTANT: To prevent fingerprint logon issues, make sure when you register your fingerprint that all sides of your finger are registered by the fingerprint reader.</p>

Special keys

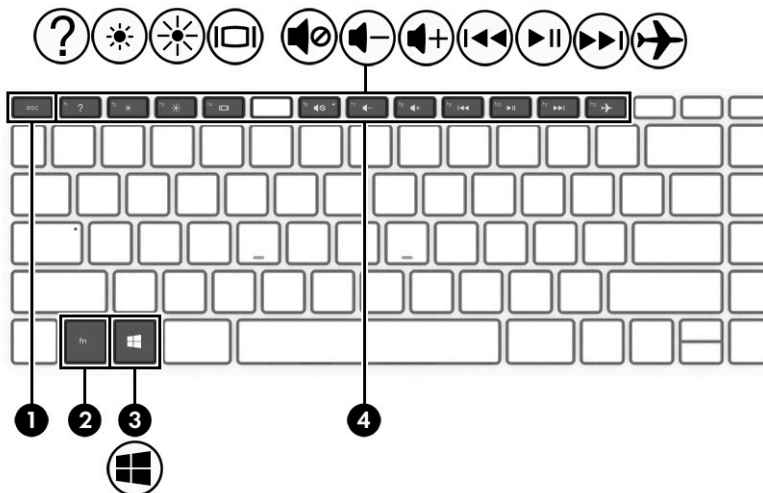

Table 2-7 Special keys and their descriptions

Component	Description
(1) <code>esc</code> key	Displays system information when pressed in combination with the <code>fn</code> key.
(2) <code>fn</code> key	Executes specific functions when pressed in combination with another key.
(3)  Windows key	Opens the Start menu.

Table 2-7 Special keys and their descriptions (continued)

Component	Description
	NOTE: Pressing the Windows key again will close the Start menu.
(4) Action keys	Execute frequently used system functions.

Bottom

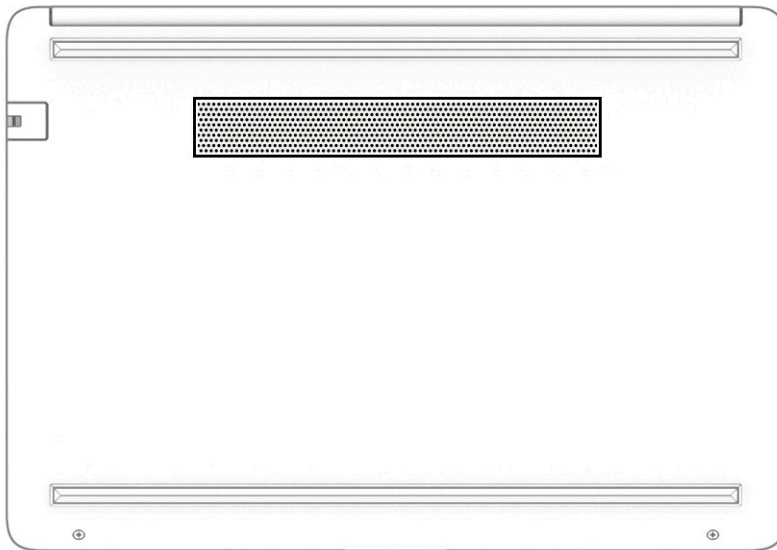

Table 2-8 Bottom component and its description

Component	Description
Vent	Enables airflow to cool internal components. NOTE: The computer fan starts up automatically to cool internal components and prevent overheating. It is normal for the internal fan to cycle on and off during routine operation.

Labels

The labels affixed to the computer provide information you might need when you troubleshoot system problems or travel internationally with the computer. Labels may be in paper form or imprinted on the product.

 **IMPORTANT:** Check the following locations for the labels described in this section: the bottom of the computer, inside the battery bay, under the service door, on the back of the display, or on the bottom of a tablet kickstand.

- Service label—Provides important information to identify your computer. When contacting support, you may be asked for the serial number, the product number, or the model number. Locate this information before you contact support.

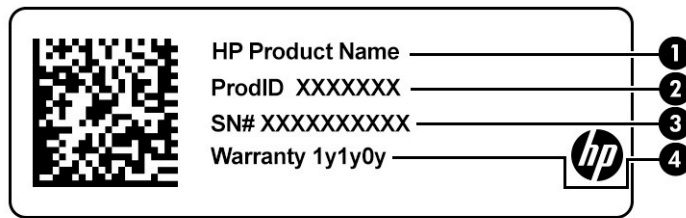

Table 2-9 Service label components

Component
(1) HP product name
(2) Product ID
(3) Serial number
(4) Warranty period

- Regulatory label(s)—Provide(s) regulatory information about the computer.
- Wireless certification label(s)—Provide(s) information about optional wireless devices and the approval markings for the countries or regions in which the devices have been approved for use.

3 Illustrated parts catalog

Computer major components

 **NOTE:** HP continually improves and changes product parts. For complete and current information about supported parts for your computer, go to <http://partsurfer.hp.com>, select your country or region, and then follow the on-screen instructions.

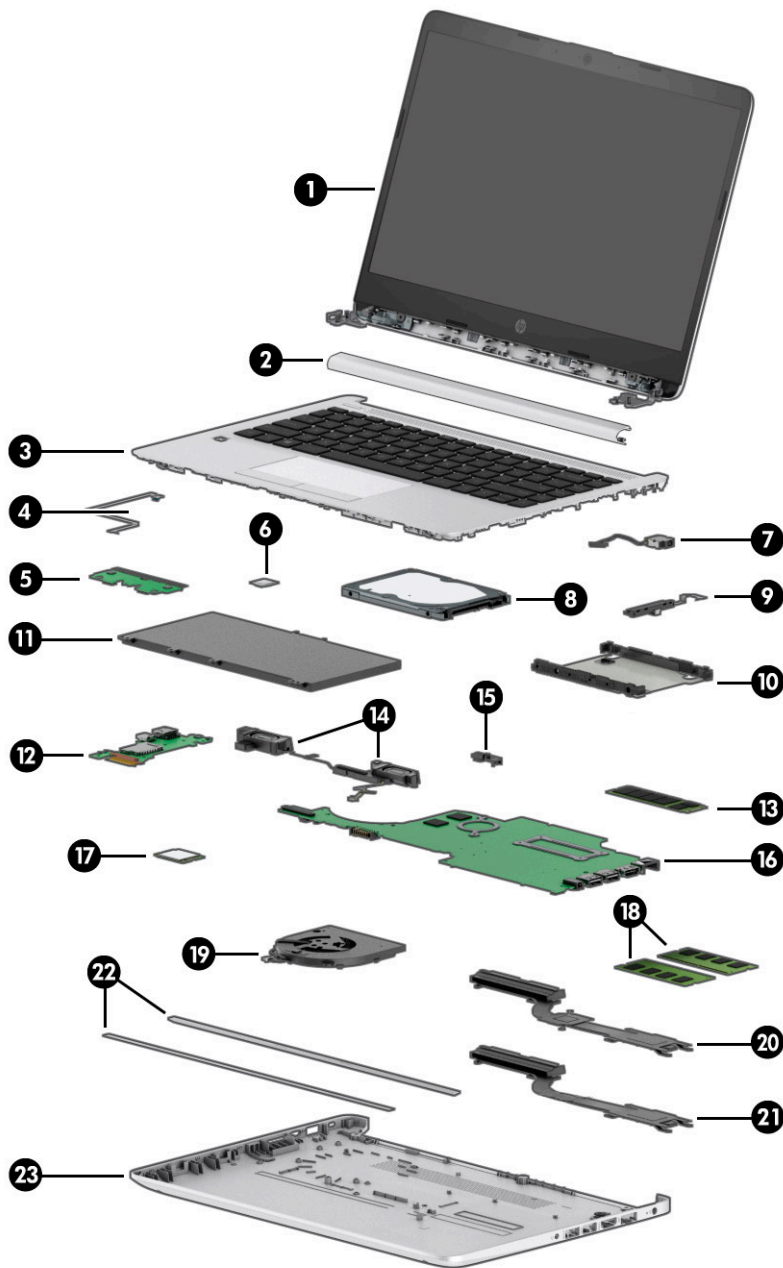

Table 3-1 Computer major components and their descriptions

Item	Component	Spare part number
(1)	Display assembly NOTE: Display spare parts are available only at the subcomponent level. For display assembly spare part information, see Display assembly subcomponents on page 18 .	
(2)	Hinge cover	
	Stone silver	L58454-001
	Pike silver	L58455-001
(3)	Top cover/keyboard (includes touchpad and touchpad top protective tape; does not include touchpad board or touchpad click board) NOTE: For a detailed list of keyboard country codes, see Top cover/keyboard on page 58 .	
	Pike silver	L81308-xx1
	Stone silver	L81309-xx1
(4)	Touchpad board cable	L23184-001
(5)	Touchpad click board NOTE: The touchpad click board cable is available as spare part number L24485-001.	L24486-001
(6)	Fingerprint sensor NOTE: The fingerprint sensor bracket is available as spare part number L84322-001. The fingerprint sensor cable is available as spare part number L81412-001.	
	Pike silver	L81413-001
	Stone silver	L81414-001
(7)	Power connector	L23188-001
(8)	Hard drive (does not include bracket)	
	1 TB, 5400 rpm, 7 mm	L30422-005
	500 GB, 7200 rpm, 7 mm	703267-005
(9)	Hard drive cable	L23187-001
(10)	Hard drive bracket	L24490-001
(11)	Battery , 3 cell, 41 Wh, prismatic/polymer	L11119-855
(12)	USB board	L81415-001
	USB board cable (not illustrated)	L81411-001
(13)	Solid-state drive	
	512 GB, PCIe	L25984-001
	256 GB, PCIe	L25983-001
	256 GB, SATA-3, TLC	L56986-001
	128 GB, SATA-3, TLC	L25981-001
	Optane memory module (16 GB)	L34406-001
(14)	Speakers	L24489-001

Table 3-1 Computer major components and their descriptions (continued)

Item	Component	Spare part number
(15)	System board hook	L23206-001
		L88007-001
(16)	System board (includes replacement thermal materials)	
	All system boards use the following part numbers:	
	xxxxxx-001: non-Windows operating system	
	xxxxxx-601: Windows operating system	
	For use in models with discrete graphics:	
	• Intel Core i7-10510U processor and 2 GB of dedicated video memory	L81423-xxx
	• Intel Core i5-10210U processor and 2 GB of dedicated video memory	L81422-xxx
	• Intel Core i3-10110U processor and 2 GB of dedicated video memory	L81419-xxx
	• Intel Core i3-8130U processor and 2 GB of dedicated video memory	L81421-xxx
	• Intel Core i3-7020U processor and 2 GB of dedicated video memory	L81420-xxx
	For use in models with UMA graphics:	
	• Intel Core i7-10510U processor	L81428-xxx
	• Intel Core i5-10210U processor	L81427-xxx
	• Intel Core i3-10110U processor	L81424-xxx
	• Intel Core i3-8130U processor	L81426-xxx
• Intel Core i3-7020U processor	L81425-xxx	
(17)	WLAN module	
	Realtek RTL8821CE 802.11ac 1 × 1 Wi-Fi + Bluetooth 4.2 Combo Adapter	L17365-005
	Intel Wi-Fi 6 AX201, 802.11ax 2 × 2 + Bluetooth 5	L57250-005
	Intel Wireless-AC 9560 802.11ac 2 × 2 Wi-Fi + Bluetooth 5	L22634-005
	Realtek RTL8822CE 802.11ac 2 × 2 Wi-Fi + Bluetooth 5 Combo Adapter	L44796-005
(18)	Memory module	
	4 GB	L10598-855
	8 GB	937236-855
	16 GB	937438-855
(19)	Fan	L23189-001
(20)	Heat sink assembly, discrete (includes replacement thermal materials)	L23192-001
(21)	Heat sink assembly, UMA (includes replacement thermal materials)	L23191-001
(22)	Rubber Feet (includes front and rear feet)	
	Natural silver	L24482-001
	Stone silver	L56985-001
(23)	Bottom cover	

Table 3-1 Computer major components and their descriptions (continued)

Item	Component	Spare part number
	Pike silver	L81409-001
	Stone silver	L81410-001

Display assembly subcomponents

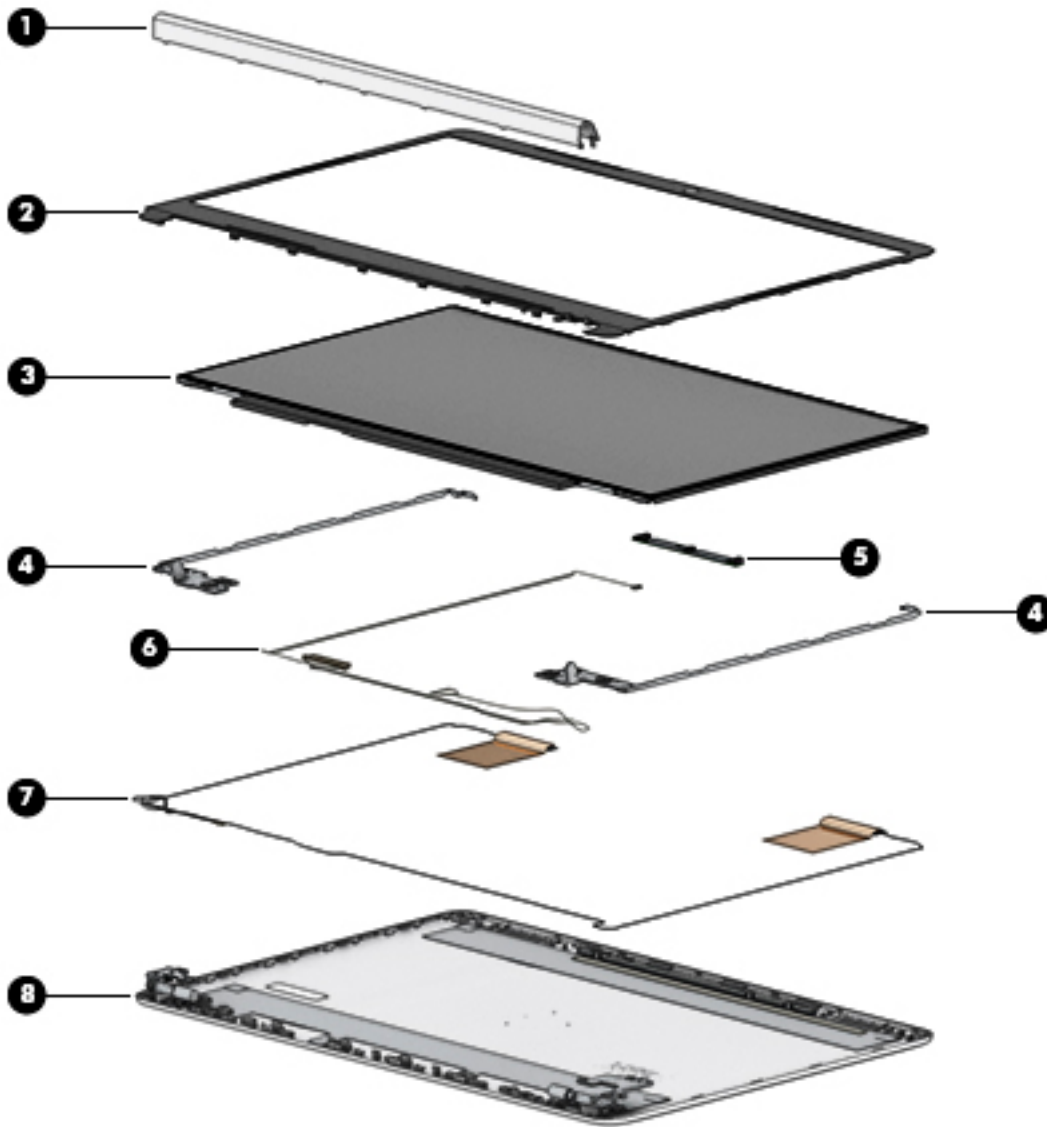

Table 3-2 Display components and their descriptions

Item	Component	Spare part number
(1)	Hinge cover	
	Stone silver	L58454-001
	Pike silver	L58455-001

Table 3-2 Display components and their descriptions (continued)

Item	Component	Spare part number
(2)	Display bezel	
	For use in models with a webcam	L56981-001
	For use in models without a webcam	L56980-001
(3)	Raw display panel (includes display panel stretchable adhesive tape)	
	FHD, UWVA	L56982-001
	HD, SVA	L56983-001
(4)	Hinges (left and right; includes display panel stretchable adhesive tape)	L24470-001
(5)	Webcam/microphone module	L56987-001
	Microphone module	L56984-001
(6)	Display cable	
	HD display	L24492-001
	FHD display	L24493-001
(7)	Antennas (includes display panel stretchable adhesive tape)	
	Dual	L24640-001
	Single	L29012-001
(8)	Display enclosure	
	Pike silver	L56978-001
	Stone silver	L56979-001

Miscellaneous parts

Table 3-3 Miscellaneous parts and their descriptions

Component	Spare part number
Display panel stretchable adhesive tape	L24491-001
Processor insulation tape	L69213-001
Fingerprint sensor insert, pike silver (for use in models without a fingerprint sensor)	L81416-001
Fingerprint sensor insert, stone silver (for use in models without a fingerprint sensor)	L81417-001
HP Smart AC adapter	
45 W, RC 4.5 mm, NPFC, nonslim	741727-001
65 W, NPFC, S-3P 4.5 mm	710412-001
65 W, NPFC, RC 4.5 mm, EM	913691-850
Power cord (3 pin, black, 1.0 m [3.3 ft]) for use in:	
For use in Europe	L19361-001
For use in India	L19363-001

Table 3-3 Miscellaneous parts and their descriptions (continued)

Component	Spare part number
For use in North America	L19367-001
For use in the People's Republic of China	L19368-001
For use in Thailand	L19371-001
For use in Taiwan	L19372-001
For use in the United Kingdom	L19373-001
Power cord (3 pin, black, 1.8 m [5.9 ft]) for use in:	
For use in the United Kingdom and Singapore	L19373-002
Screw Kit	L81418-001

4 Removal and replacement procedures preliminary requirements

Tools required

You need the following tools to complete the removal and replacement procedures:

- Nonconductive, nonmarking pry tool
- Magnetic Phillips P1 screwdriver
- Tweezers

Service considerations

The following sections include some of the considerations that you must keep in mind during disassembly and assembly procedures.

 **NOTE:** As you remove each subassembly from the computer, place the subassembly (and all accompanying screws) away from the work area to prevent damage.

Plastic parts

 **IMPORTANT:** Using excessive force during disassembly and reassembly can damage plastic parts.

Cables and connectors

 **IMPORTANT:** When servicing the computer, be sure that cables are placed in their proper locations during the reassembly process. Improper cable placement can damage the computer.

Cables must be handled with extreme care to avoid damage. Apply only the tension required to unseat or seat the cables during removal and insertion. Handle cables by the connector whenever possible. In all cases, avoid bending, twisting, or tearing cables. Be sure that cables are routed in such a way that they cannot be caught or snagged by parts being removed or replaced. Handle flex cables with extreme care; these cables tear easily.

Drive handling



IMPORTANT: Drives are fragile components that must be handled with care. To prevent damage to the computer, damage to a drive, or loss of information, observe these precautions:

Before removing or inserting a hard drive, shut down the computer. If you are unsure whether the computer is off or in Hibernation, turn the computer on, and then shut it down through the operating system.

Before handling a drive, be sure that you are discharged of static electricity. While handling a drive, avoid touching the connector.

Before removing an optical drive, be sure that a disc is not in the drive and be sure that the optical drive tray is closed.

Handle drives on surfaces covered with at least 2.54 cm (1 inch) of shock-proof foam.

Avoid dropping drives from any height onto any surface.

After removing a hard drive or an optical drive, place it in a static-proof bag.

Avoid exposing an internal hard drive to products that have magnetic fields, such as monitors or speakers.

Avoid exposing a drive to temperature extremes or liquids.

If a drive must be mailed, place the drive in a bubble pack mailer or other suitable form of protective packaging and label the package “FRAGILE.”

Workstation guidelines

Follow these grounding workstation guidelines:

- Cover the workstation with approved static-shielding material.
- Use a wrist strap connected to a properly grounded work surface and use properly grounded tools and equipment.
- Use conductive field service tools, such as cutters, screw drivers, and vacuums.
- When fixtures must directly contact dissipative surfaces, use fixtures made only of static-safe materials.
- Keep the work area free of nonconductive materials, such as ordinary plastic assembly aids and polystyrene foam.
- Handle ESD-sensitive components, parts, and assemblies by the case or PCM laminate. Handle these items only at static-free workstations.
- Avoid contact with pins, leads, or circuitry.
- Turn off power and input signals before inserting or removing connectors or test equipment.

Electrostatic discharge information

A sudden discharge of static electricity from your finger or other conductor can destroy static-sensitive devices or microcircuitry. Often the spark is neither felt nor heard, but damage occurs. An electronic device exposed to electrostatic discharge (ESD) might not appear to be affected at all and can work perfectly throughout a normal cycle. The device might function normally for a while, but it has been degraded in the internal layers, reducing its life expectancy.

Networks built into many integrated circuits provide some protection, but in many cases, the discharge contains enough power to alter device parameters or melt silicon junctions.



IMPORTANT: To prevent damage to the device when you are removing or installing internal components, observe these precautions:

Keep components in their electrostatic-safe containers until you are ready to install them.

Before touching an electronic component, discharge static electricity by using the guidelines described in this section.

Avoid touching pins, leads, and circuitry. Handle electronic components as little as possible.

If you remove a component, place it in an electrostatic-safe container.

Generating static electricity

Note the following:

- Different activities generate different amounts of static electricity.
- Static electricity increases as humidity decreases.

Table 4-1 Static electricity occurrence based on activity and humidity

Event	Relative humidity		
	55%	40%	10%
Walking across carpet	7,500 V	15,000 V	35,000 V
Walking across vinyl floor	3,000 V	5,000 V	12,000 V
Motions of bench worker	400 V	800 V	6,000 V
Removing DIPs (dual in-line packages) from plastic tube	400 V	700 V	2,000 V
Removing DIPs from vinyl tray	2,000 V	4,000 V	11,500 V
Removing DIPs from polystyrene foam	3,500 V	5,000 V	14,500 V
Removing bubble pack from PCB (printed circuit board)	7,000 V	20,000 V	26,500 V
Packing PCBs in foam-lined box	5,000 V	11,000 V	21,000 V

Multiple electric components can be packaged together in plastic tubes, trays, or polystyrene foam.



NOTE: As little as 700 V can degrade a product.

Preventing electrostatic damage to equipment

Many electronic components are sensitive to ESD. Circuitry design and structure determine the degree of sensitivity. The following packaging and grounding precautions are necessary to prevent static electricity damage to electronic components.

- To avoid hand contact, transport products in static-safe containers such as tubes, bags, or boxes.
- Protect all electrostatic parts and assemblies with conductive or approved containers or packaging.
- Keep electrostatic-sensitive parts in their containers until they arrive at static-free stations.
- Place items on a grounded surface before removing them from their container.
- Always be properly grounded when touching a sensitive component or assembly.

- Avoid contact with pins, leads, or circuitry.
- Place reusable electrostatic-sensitive parts from assemblies in protective packaging or conductive foam.

Personal grounding methods and equipment

Use the following equipment to prevent static electricity damage to electronic components:

- **Wrist straps** are flexible straps with a maximum of $1\text{ M}\Omega \pm 10\%$ resistance in the ground cords. To provide proper ground, a strap must be worn snug against bare skin. The ground cord must be connected and fit snugly into the banana plug connector on the grounding mat or workstation.
- **Heel straps/Toe straps/Boot straps** can be used at standing workstations and are compatible with most types of shoes or boots. On conductive floors or dissipative floor mats, use them on both feet with a maximum of $1\text{ M}\Omega \pm 10\%$ resistance between the operator and ground.

Table 4-2 Static shielding protection levels

Static shielding protection levels	
Method	Voltage
Antistatic plastic	1,500
Carbon-loaded plastic	7,500
Metallized laminate	15,000

Grounding the work area

To prevent static damage at the work area, use the following precautions:

- Cover the work surface with approved static-dissipative material. Provide a wrist strap connected to the work surface and properly grounded tools and equipment.
- Use static-dissipative mats, foot straps, or air ionizers to give added protection.
- Handle electrostatic sensitive components, parts, and assemblies by the case or PCB laminate. Handle them only at static-free work areas.
- Turn off power and input signals before inserting and removing connectors or test equipment.
- Use fixtures made of static-safe materials when fixtures must directly contact dissipative surfaces.
- Keep work area free of nonconductive materials such as ordinary plastic assembly aids and polystyrene foam.
- Use field service tools, such as cutters, screwdrivers, and vacuums, that are conductive.

Recommended materials and equipment

HP recommends the following materials and equipment to prevent static electricity:

- Antistatic tape
- Antistatic smocks, aprons, or sleeve protectors
- Conductive bins and other assembly or soldering aids
- Conductive foam
- Conductive tabletop workstations with ground cord of $1\text{ M}\Omega \pm 10\%$ resistance

- Static-dissipative table or floor mats with hard tie to ground
- Field service kits
- Static awareness labels
- Wrist straps and footwear straps providing $1\text{ M}\Omega \pm 10\%$ resistance
- Material handling packages
- Conductive plastic bags
- Conductive plastic tubes
- Conductive tote boxes
- Opaque shielding bags
- Transparent metallized shielding bags
- Transparent shielding tubes

Packaging and transporting guidelines

Follow these grounding guidelines when packaging and transporting equipment:

- To avoid hand contact, transport products in static-safe tubes, bags, or boxes.
- Protect ESD-sensitive parts and assemblies with conductive or approved containers or packaging.
- Keep ESD-sensitive parts in their containers until the parts arrive at static-free workstations.
- Place items on a grounded surface before removing items from their containers.
- Always be properly grounded when touching a component or assembly.
- Store reusable ESD-sensitive parts from assemblies in protective packaging or nonconductive foam.
- Use transporters and conveyors made of antistatic belts and roller bushings. Be sure that mechanized equipment used for moving materials is wired to ground and that proper materials are selected to avoid static charging. When grounding is not possible, use an ionizer to dissipate electric charges.

5 Removal and replacement procedures for authorized service provider parts

 **IMPORTANT:** Components described in this chapter should be accessed only by an authorized service provider. Accessing these parts can damage the computer or void the warranty.

 **NOTE:** HP continually improves and changes product parts. For complete and current information about supported parts for your computer, go to <http://partsurfer.hp.com>, select your country or region, and then follow the on-screen instructions.

Component replacement procedures

 **NOTE:** Details about your computer, including model, serial number, product key, and length of warranty, are on the service tag at the bottom of your computer.

There are as many as 58 screws that must be removed, replaced, or loosened when servicing Authorized Service Provider only parts. Make special note of each screw size and location during removal and replacement.

Preparation for disassembly

See [Removal and replacement procedures preliminary requirements on page 21](#) for initial safety procedures.

1. Turn off the computer. If you are unsure whether the computer is off or in Hibernation, turn the computer on, and then shut it down through the operating system.
2. Disconnect the power from the computer by unplugging the power cord from the computer.
3. Disconnect all external devices from the computer.

Computer feet

Table 5-1 Computer feet description and part number

Description	Spare part number
Computer feet, natural silver	L24482-001
Computer feet, stone silver	L56985-001

Before removing the computer feet, follow these steps:

- ▲ Prepare the computer for disassembly ([Preparation for disassembly on page 27](#)).

Remove the computer feet:

1. Close the computer and position it upside down, with the front toward you.
2. Insert a tool with no sharp edges between the base enclosure and one end of the rubber feet.

3. Pull up the rubber feet lightly and quickly.

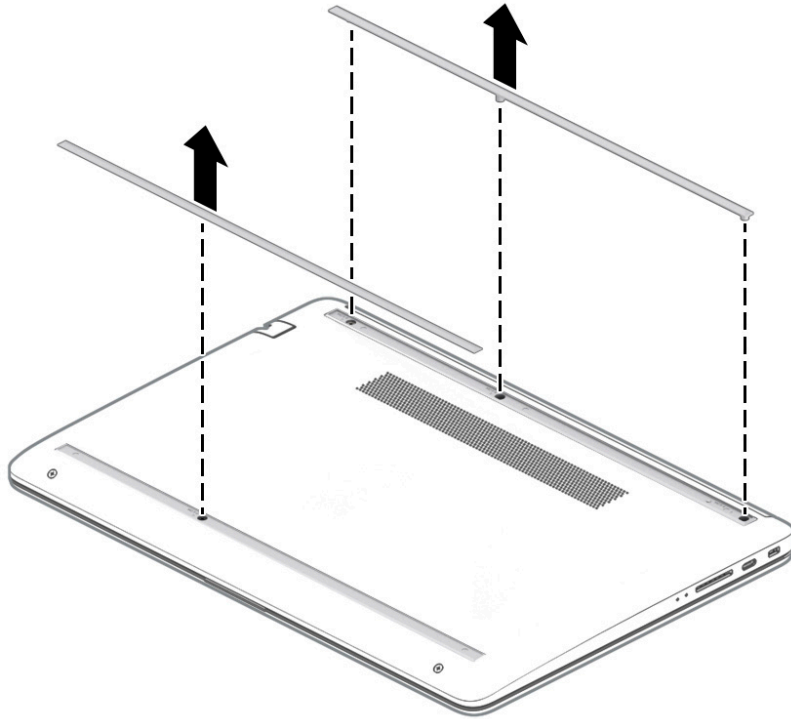

To install the rubber feet, refit them on the adhesive backing.



NOTE: The bottoms of the computer feet are ribbed. These ribs are designed to fit only one way in the grooves that are in the enclosure. Make sure the feet are positioned in those grooves when reinstalling the feet.

Bottom cover

Table 5-2 Bottom cover descriptions and part numbers

Description	Spare part number
Bottom cover, pike silver	L81409-001
Bottom cover, stone silver	L81410-001

Before removing the bottom cover, follow these steps:

1. Prepare the computer for disassembly ([Preparation for disassembly on page 27](#)).
2. Remove the rubber feet (see [Computer feet on page 27](#)).

To remove the bottom cover:

1. Remove the four Phillips M2.5 × 6.0 screws **(1)** from under the feet and the two Phillips M2.5 × 4.0 screws **(2)** from the front part of the bottom cover.

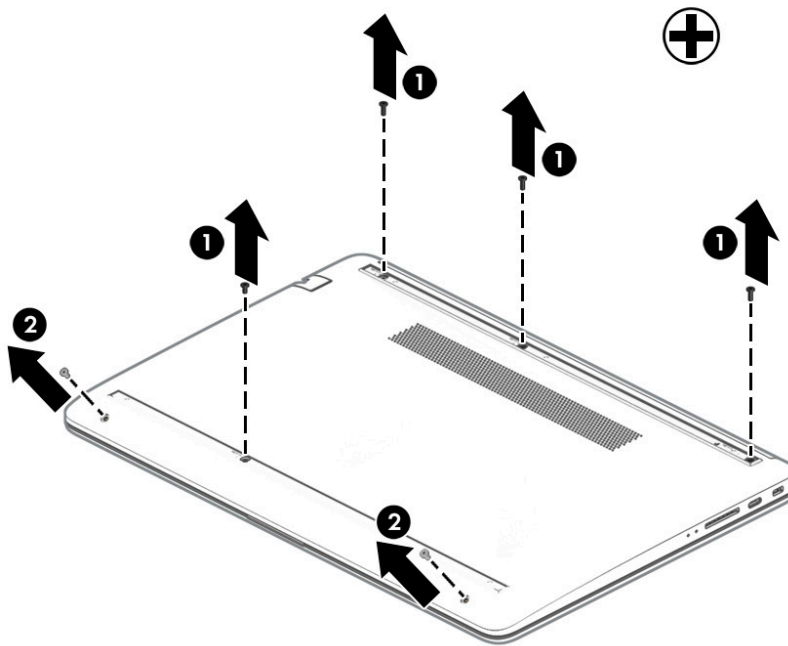

2. Use a thin plastic tool **(1)** to release the back cover. Work your way around releasing the bottom cover from the computer, and then remove the cover **(2)**.

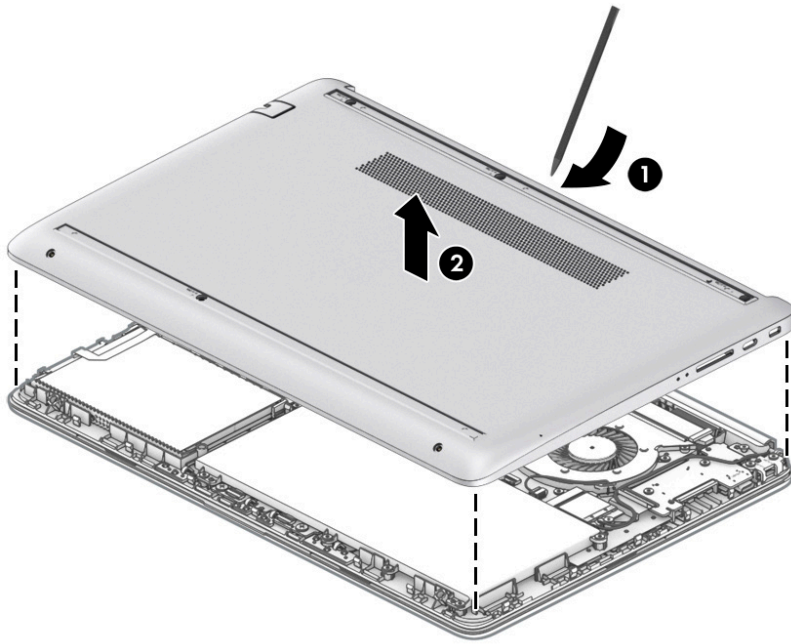

Reverse this procedure to install the bottom cover.

Battery

Table 5-3 Battery and system board hook descriptions and part numbers

Description	Spare part number
Battery	L11119-855
System board hook	L23206-001
	L88007-001

Before removing the battery and system board hook, follow these steps:

1. Prepare the computer for disassembly ([Preparation for disassembly on page 27](#)).
2. Remove the rubber feet (see [Computer feet on page 27](#)).
3. Remove the bottom cover (see [Bottom cover on page 29](#)).

To remove the battery and system board hook:

1. Remove the four Phillips M2.5 × 4.0 screws (1) that secure the battery.
2. Lift the top of the battery (2), and then remove the system board hook and the battery from the computer (3).

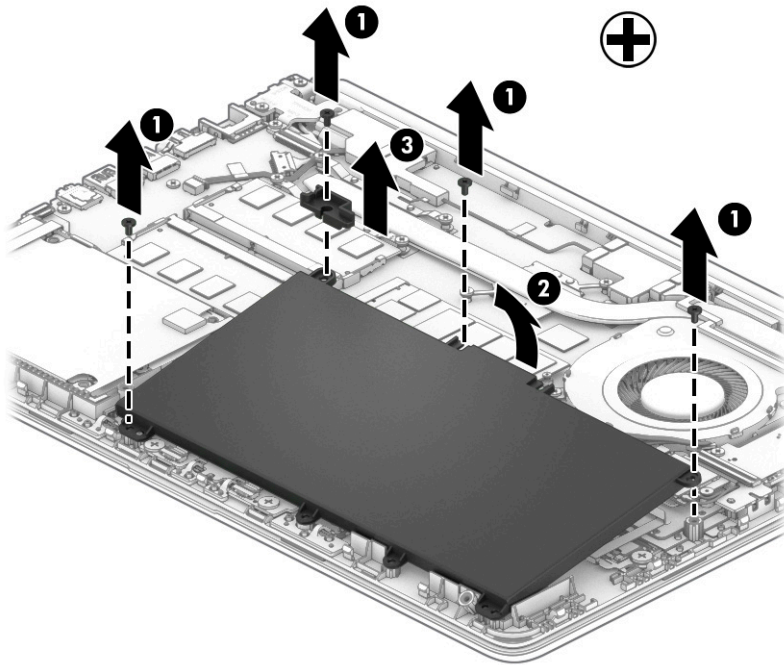

Reverse this procedure to install the battery.

Hard drive



NOTE: The hard drive spare part kit does not include the hard drive cover.

Table 5-4 Hard drive descriptions and part numbers

Description	Spare part number
Hard drive, 1 TB, 5400 rpm, 7 mm	L30422-005
Hard drive, 500 GB, 7200 rpm, 7 mm	703267-005
Hard drive cable	L23187-001
Hard drive bracket	L24490-001

Before removing the hard drive, follow these steps:

1. Prepare the computer for disassembly ([Preparation for disassembly on page 27](#)).
2. Remove the rubber feet (see [Computer feet on page 27](#)).
3. Remove the bottom cover (see [Bottom cover on page 29](#)).
4. Remove the battery (see [Battery on page 31](#)).

To remove the hard drive:

1. Open the hard drive ZIF connector on the system board **(1)**, and then disconnect the hard drive cable **(2)**.
2. Lift the front of the hard drive **(3)**, and then remove it **(4)** from the computer.

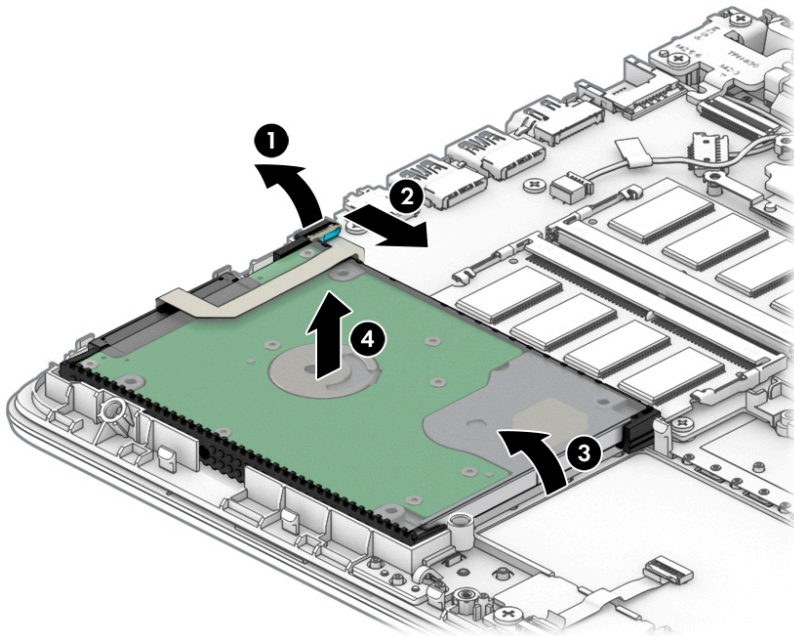

3. To remove the hard drive bracket and connector cable, pull the sides of the bracket up and away from the hard drive **(1)**, and then remove the bracket from the hard drive **(2)**.

4. Pull the connector off of the hard drive (3).

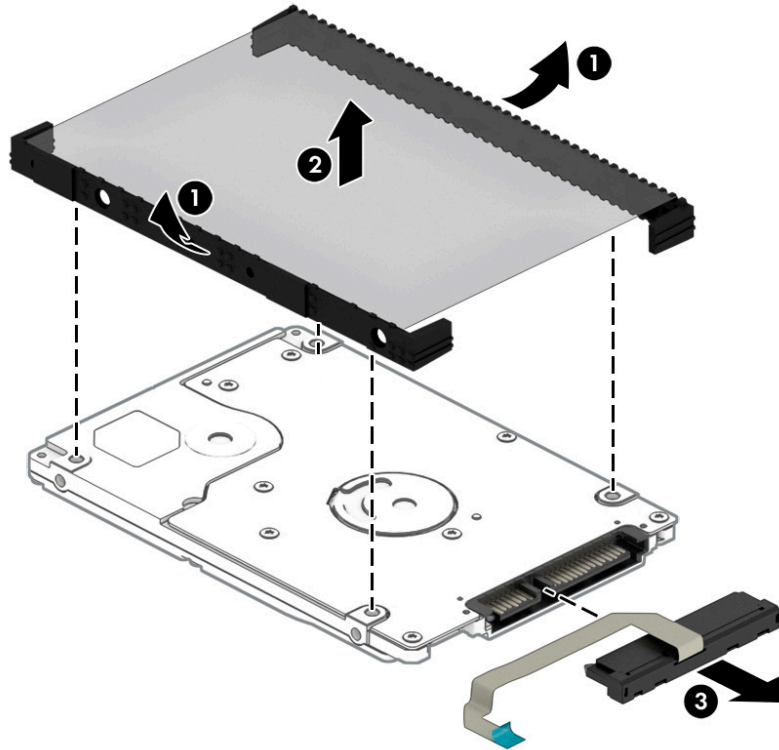

Reverse this procedure to reassemble and install the hard drive.

WLAN module

Table 5-5 WLAN module descriptions and part numbers

Description	Spare part number
Realtek RTL8821CE 802.11ac 1 × 1 Wi-Fi + Bluetooth 4.2 Combo Adapter (MU-MIMO supported)	L17365-005
Intel Wi-Fi 6 AX201, 802.11ax 2 × 2 + Bluetooth 5 (non-vPro, supporting gigabit file transfer speeds)	L57250-005
Intel Wireless-AC 9560 802.11ac 2 × 2 Wi-Fi + Bluetooth 5	L22634-005
Realtek RTL8822CE 802.11ac 2 × 2 Wi-Fi + Bluetooth 5 Combo Adapter	L44796-005

 **IMPORTANT:** To prevent an unresponsive system, replace the wireless module only with a wireless module authorized for use in the computer by the governmental agency that regulates wireless devices in your country or region. If you replace the module and then receive a warning message, remove the module to restore device functionality, and then contact support.

Before removing the WLAN module, follow these steps:

1. Prepare the computer for disassembly ([Preparation for disassembly on page 27](#)).
2. Remove the rubber feet (see [Computer feet on page 27](#)).
3. Remove the bottom cover (see [Bottom cover on page 29](#)).
4. Remove the battery (see [Battery on page 31](#)).

To remove the WLAN module:

1. Disconnect the WLAN antenna cables **(1)** from the terminals on the WLAN module.

 **NOTE:** The #1 WLAN antenna cable is connected to the WLAN module **Main** terminal. The #2 WLAN antenna cable is connected to the WLAN module **Aux** terminal.

2. Remove the Phillips M2.0 × 3.0 screw **(2)** that secures the WLAN module to the system board. (The WLAN module tilts up.)

3. Remove the WLAN module by pulling the module away from the slot at an angle (3).

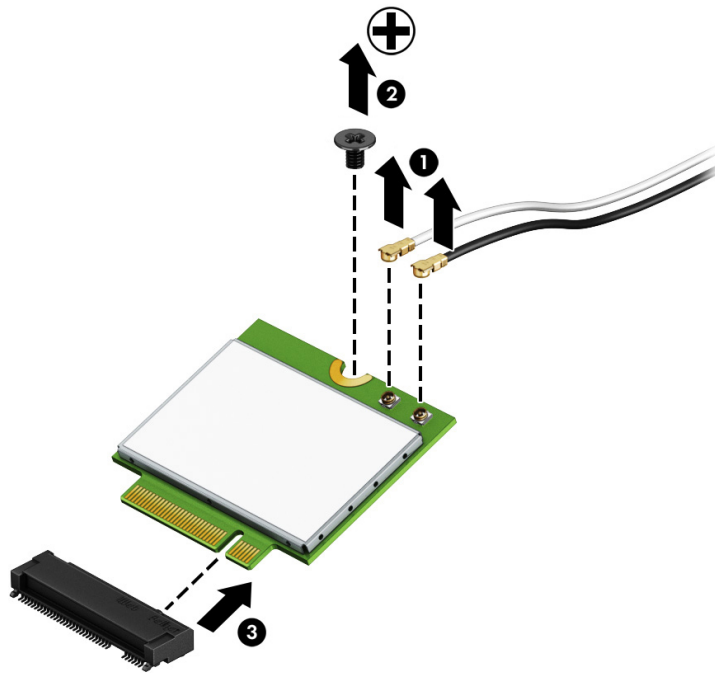

 **NOTE:** If the WLAN antennas are not connected to the terminals on the WLAN module, the protective sleeves must be installed on the antenna connectors, as shown in the following illustration.

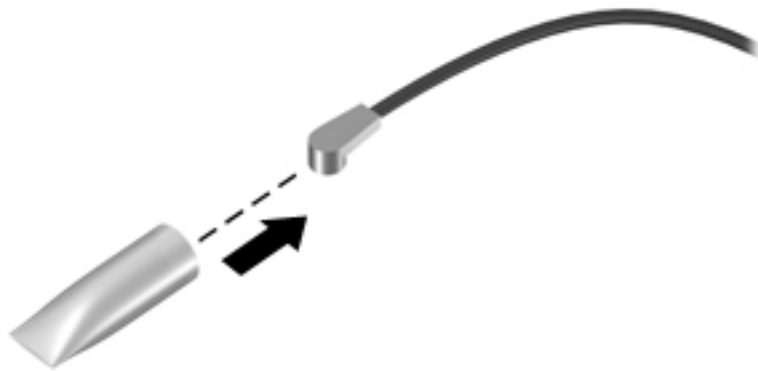

Reverse this procedure to install the WLAN module.

Memory module

Table 5-6 Memory module descriptions and part numbers

Description	Spare part number
4 GB memory module (SODIMM)	L10598-855
8 GB memory module (SODIMM)	937236-855
16 GB memory module (SODIMM)	937438-855

Before removing a memory module, follow these steps:

1. Prepare the computer for disassembly ([Preparation for disassembly on page 27](#)).
2. Remove the rubber feet (see [Computer feet on page 27](#)).
3. Remove the bottom cover (see [Bottom cover on page 29](#)).
4. Remove the battery (see [Battery on page 31](#)).

To remove a memory module:

1. Spread the retaining tabs **(1)** on each side of the memory module slot to release the memory module. (The memory module tilts up.)
2. Remove the memory module by pulling it away from the slot at an angle **(2)**.

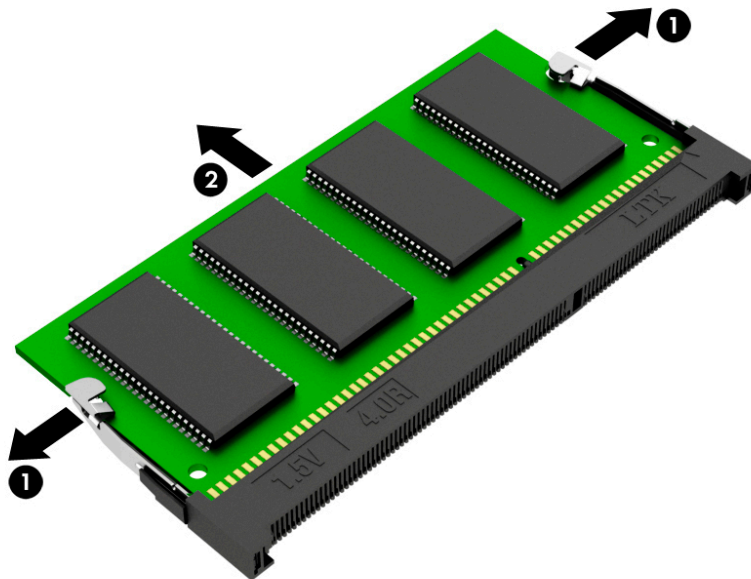

Reverse this procedure to install a memory module.

Solid-state drive

Table 5-7 Solid-state drive descriptions and part numbers

Description	Spare part number
Solid-state drive, 512 GB, PCIe	L25984-001
Solid-state drive, 256 GB, PCIe	L25983-001
Solid-state drive, 256 GB, SATA-3	L56986-001
Solid-state drive, 128 GB, SATA-3	L25981-001
Optane memory module, 16 GB	L34406-001

Before removing the solid-state drive, follow these steps:

1. Prepare the computer for disassembly ([Preparation for disassembly on page 27](#)).
2. Remove the rubber feet (see [Computer feet on page 27](#)).
3. Remove the bottom cover (see [Bottom cover on page 29](#)).
4. Remove the battery (see [Battery on page 31](#)).

Remove the solid-state drive:

1. Remove the Phillips M2.0 × 2.0 screw **(1)** that secures the drive to the system board.
2. Remove the drive by pulling it away from the connector **(2)**.

 **NOTE:** Solid-state drives are designed with notches to prevent incorrect insertion.

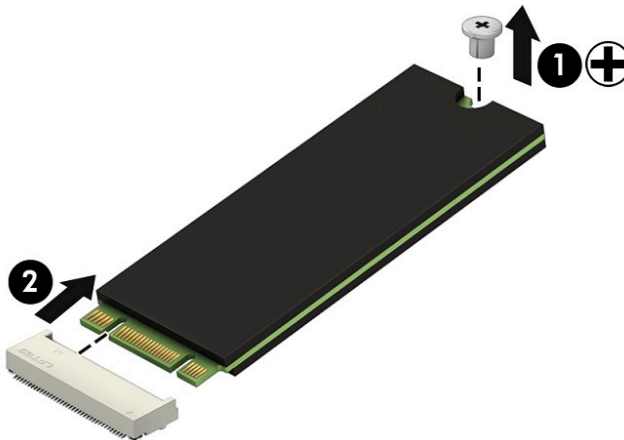

Reverse this procedure to install the solid-state drive.

Speakers

Table 5-8 Speaker description and part number

Description	Spare part number
Speakers (includes left and right speakers and cable)	926558-001

Before removing the speakers, follow these steps:

1. Prepare the computer for disassembly ([Preparation for disassembly on page 27](#)).
2. Remove the rubber feet (see [Computer feet on page 27](#)).
3. Remove the bottom cover (see [Bottom cover on page 29](#)).
4. Remove the battery (see [Battery on page 31](#)).

To remove the speakers:

1. Disconnect the speaker cable from the system board **(1)**.
2. Remove the tape **(2)** that secures the cable.
3. Lift the speakers out of the computer **(3)**.

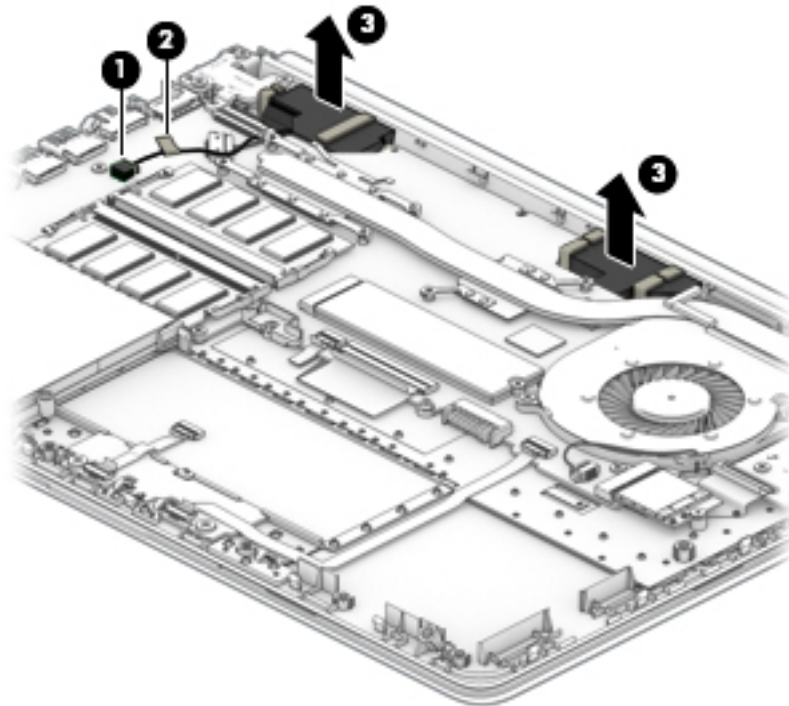

Reverse this procedure to install the speakers.

Fingerprint sensor

Table 5-9 Fingerprint sensor description and part number

Description	Spare part number
Fingerprint sensor, pike silver	L81413-001
Fingerprint sensor, stone silver	L81414-001
Fingerprint sensor bracket	L84322-001
Fingerprint sensor cable	L81412-001

Before removing the fingerprint sensor, follow these steps:

1. Prepare the computer for disassembly ([Preparation for disassembly on page 27](#)).
2. Remove the rubber feet (see [Computer feet on page 27](#)).
3. Remove the bottom cover (see [Bottom cover on page 29](#)).
4. Remove the battery (see [Battery on page 31](#)).

To remove the fingerprint sensor:

1. Disconnect the cable **(1)** from the ZIF connector on the system board, and then lift the cable to release it from the computer **(2)**.
2. Remove the two Phillips M2.0 × 2.0 screws **(3)** that secure the sensor bracket to the computer, and then remove the bracket **(4)**.
3. From the bottom, push up on the fingerprint sensor **(5)** to remove it.

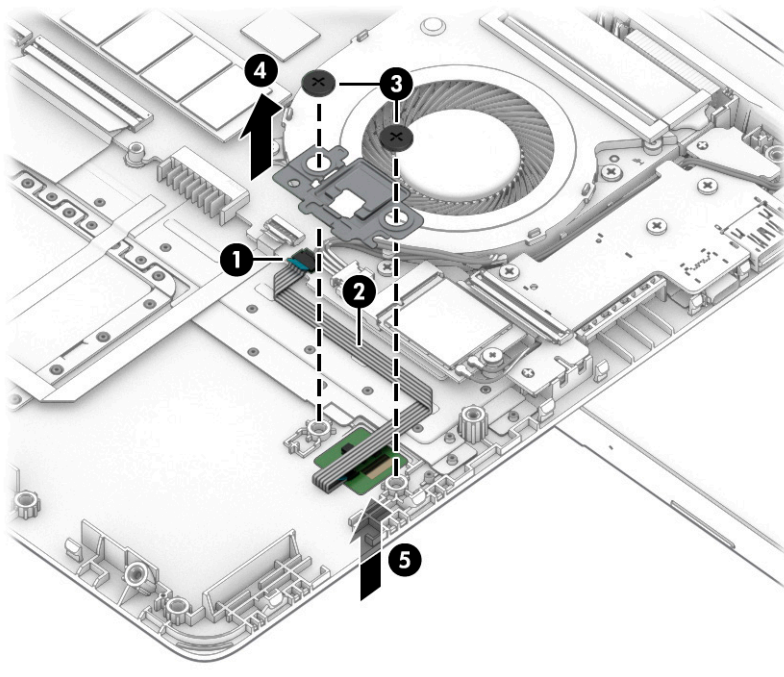

Reverse this procedure to install the fingerprint sensor.

Power connector

Table 5-10 Power connector description and part number

Description	Spare part number
Power connector	L23188-001

Before removing the power connector cable, follow these steps:

1. Prepare the computer for disassembly ([Preparation for disassembly on page 27](#)).
2. Remove the rubber feet (see [Computer feet on page 27](#)).
3. Remove the bottom cover (see [Bottom cover on page 29](#)).
4. Remove the battery (see [Battery on page 31](#)).
5. Lift the right hinge to the upright position (see [Display assembly on page 51](#)).

To remove the power connector:

1. Disconnect the power connector cable **(1)** from the system board.
2. Lift the power connector **(2)** to remove it.

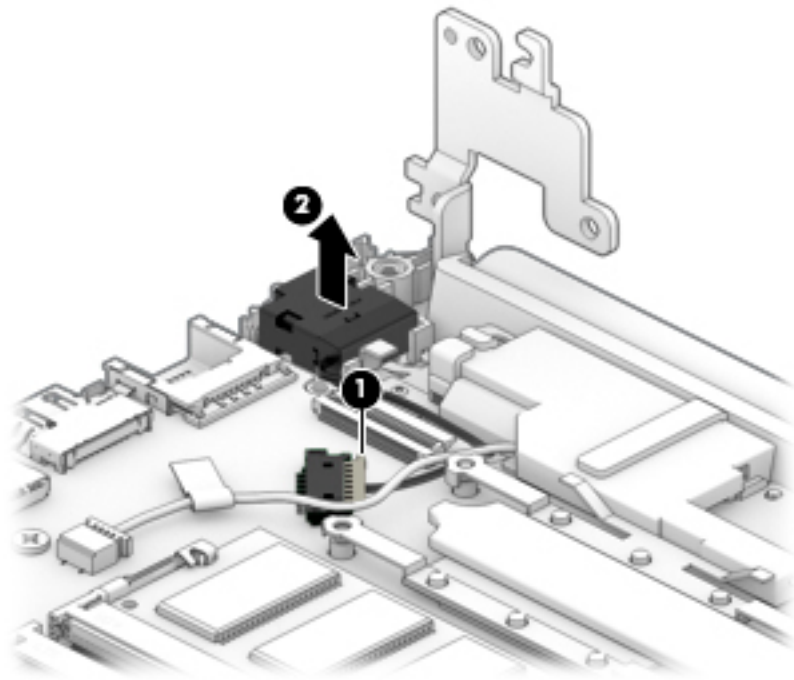

Reverse this procedure to install the power connector.

Touchpad click board

Table 5-11 Touchpad click board and cables descriptions and part numbers

Description	Spare part number
Touchpad click board	L24486-001
Touchpad board cable	L23184-001
Touchpad click board cable	L24485-001

Before removing the touchpad click board, follow these steps:

1. Prepare the computer for disassembly ([Preparation for disassembly on page 27](#)).
2. Remove the rubber feet (see [Computer feet on page 27](#)).
3. Remove the bottom cover (see [Bottom cover on page 29](#)).
4. Remove the battery (see [Battery on page 31](#)).

To remove the touchpad click board:

1. Disconnect the touchpad cable **(1)** from the touchpad board ZIF connector, and then disconnect from the touchpad click board cable **(2)** from the touchpad ZIF connector.
2. Remove the two Phillips M2.0 × 2.0 screws **(3)** that secure the touchpad click board to the computer.
3. Lift the tape that secures the board to the computer **(4)**, and then remove the board from the computer **(5)**.

 **TIP:** The edge of the board sits under clips. Be sure to slide the board out from under the clips to prevent damage to the board or clips.

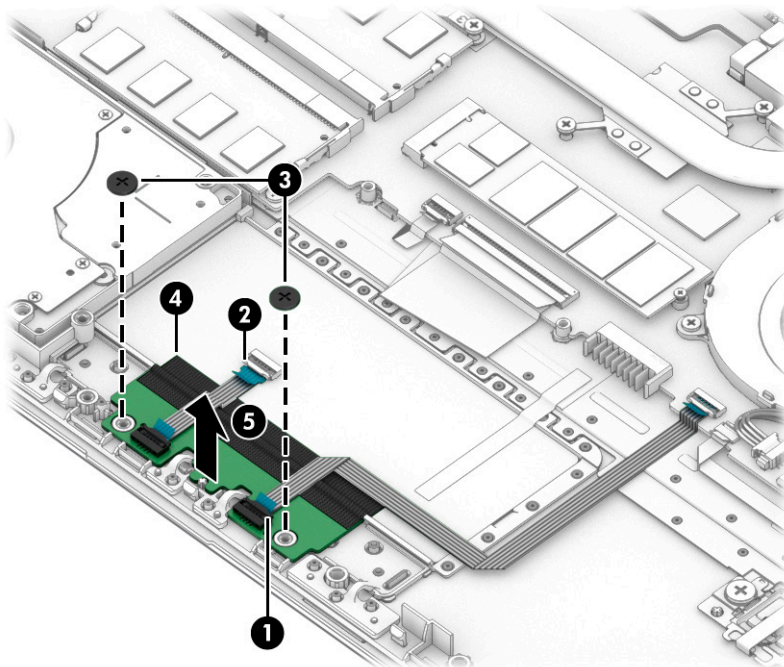

Reverse this procedure to install the touchpad click board.

Touchpad

Table 5-12 Touchpad description and part number

Description	Spare part number
Touchpad (includes gasket)	L24484-001

Before removing the touchpad, follow these steps:

1. Prepare the computer for disassembly ([Preparation for disassembly on page 27](#)).
2. Remove the rubber feet (see [Computer feet on page 27](#)).
3. Remove the bottom cover (see [Bottom cover on page 29](#)).
4. Remove the battery (see [Battery on page 31](#)).
5. Remove the touchpad click board (see [Touchpad click board on page 41](#)).

To remove the touchpad:

1. Peel the conductive tape off the keyboard **(1)**.
2. Lift the touchpad to remove it from the computer **(2)**.

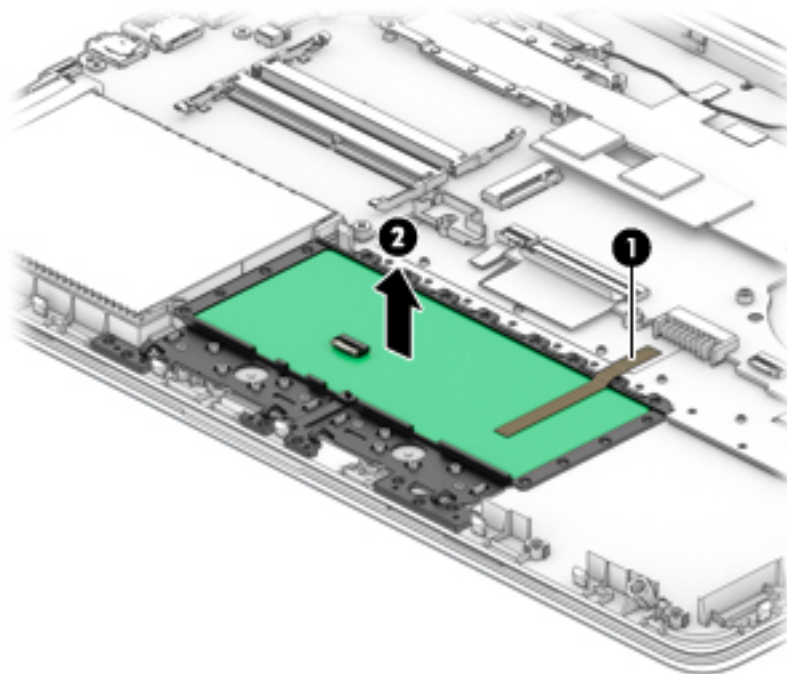

Reverse this procedure to install the touchpad board.

USB board

Table 5-13 USB board and cable descriptions and part numbers

Description	Spare part number
USB board	L81415-001
USB board cable	L81411-001

Before removing the USB board, follow these steps:

1. Prepare the computer for disassembly ([Preparation for disassembly on page 27](#)).
2. Remove the rubber feet (see [Computer feet on page 27](#)).
3. Remove the bottom cover (see [Bottom cover on page 29](#)).
4. Remove the battery (see [Battery on page 31](#)).

To remove the USB board:

1. Disconnect the cable from the ZIF connector on the USB board **(1)**
2. Move the WLAN antenna cables that route over the USB board **(2)**
3. Remove the three Phillips M2.0 × 3.0 screws **(3)** that secure the USB board to the computer.
4. Remove the USB board from the computer **(4)**.

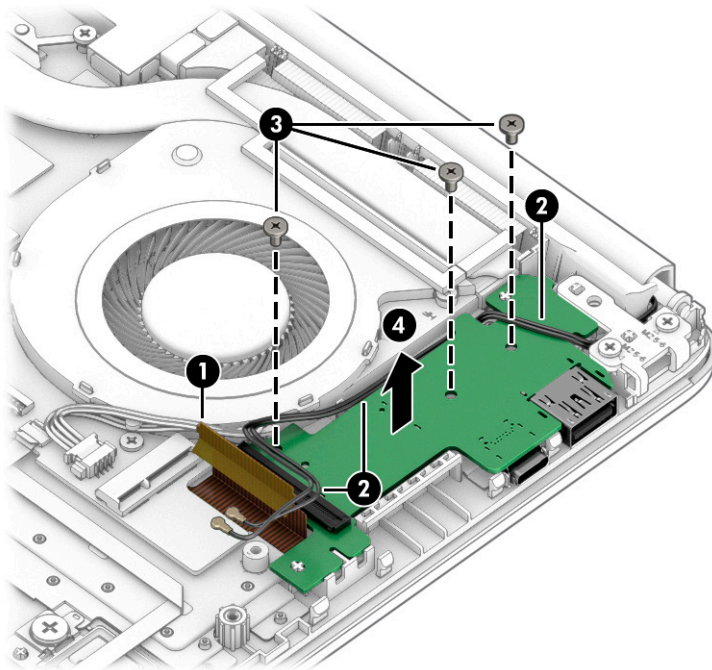

Reverse this procedure to install the USB board.

Fan

Table 5-14 Fan description and part number

Description	Spare part number
Fan	L23189-001

Before removing the fan, follow these steps:

1. Prepare the computer for disassembly ([Preparation for disassembly on page 27](#)).
2. Remove the rubber feet (see [Computer feet on page 27](#)).
3. Remove the bottom cover (see [Bottom cover on page 29](#)).
4. Remove the battery (see [Battery on page 31](#)).

To remove the fan:

1. Disconnect the fan cable from the system board **(1)**.
2. Remove the two Phillips M2.5 × 5.0 screws **(2)** that secure the fan to the computer.
3. Lift the fan out of the computer **(3)**.

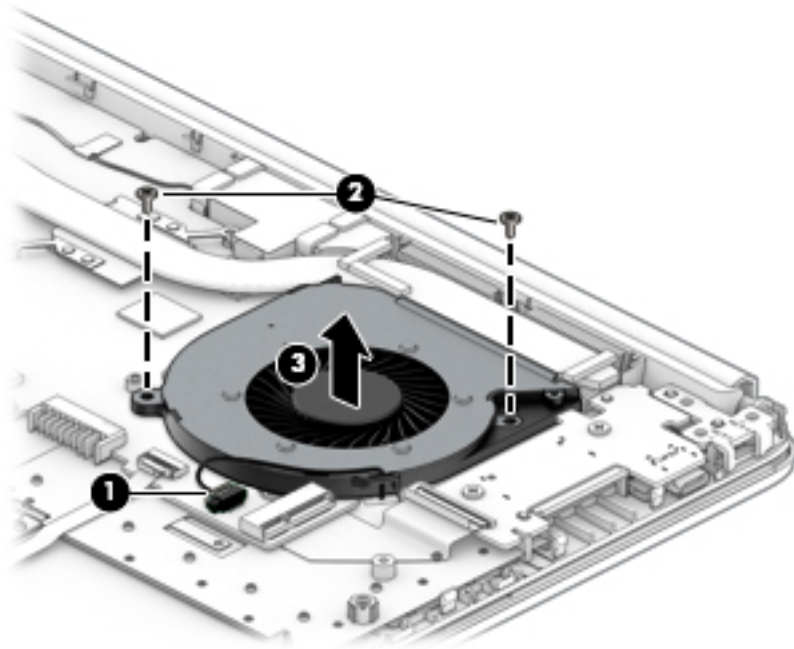

Reverse this procedure to install the fan.

System board



NOTE: The system board spare part kit includes replacement thermal materials.

Table 5-15 System board descriptions and part numbers

Description	Spare part number
System board (includes replacement thermal materials):	
All system boards use the following part numbers:	
xxxxxx-001: Non-Windows operating system	
xxxxxx-601: Windows operating system	
For use in models with discrete graphics:	
<ul style="list-style-type: none">Intel Core i7-10510U processor and 2 GB of dedicated video memory	L81423-xxx
<ul style="list-style-type: none">Intel Core i5-10210U processor and 2 GB of dedicated video memory	L81422-xxx
<ul style="list-style-type: none">Intel Core i3-10110U processor and 2 GB of dedicated video memory	L81419-xxx
<ul style="list-style-type: none">Intel Core i3-8130U processor and 2 GB of dedicated video memory	L81421-xxx
<ul style="list-style-type: none">Intel Core i3-7020U processor and 2 GB of dedicated video memory	L81420-xxx
For use in models with UMA graphics:	
<ul style="list-style-type: none">Intel Core i7-10510U processor	L81428-xxx
<ul style="list-style-type: none">Intel Core i5-10210U processor	L81427-xxx
<ul style="list-style-type: none">Intel Core i3-10110U processor	L81424-xxx
<ul style="list-style-type: none">Intel Core i3-8130U processor	L81426-xxx
<ul style="list-style-type: none">Intel Core i3-7020U processor	L81425-xxx

Before removing the system board, follow these steps:

1. Prepare the computer for disassembly ([Preparation for disassembly on page 27](#)).
2. Remove the rubber feet (see [Computer feet on page 27](#)).
3. Remove the bottom cover (see [Bottom cover on page 29](#)).
4. Remove the battery (see [Battery on page 31](#)).
5. Remove the fan (see [Fan on page 44](#)).
6. Remove the speakers (see [Speakers on page 38](#)).



NOTE: When replacing the system board, be sure that the following components are removed from the defective system board and installed on the replacement system board:

- WLAN module (see [WLAN module on page 34](#))
- Memory modules (see [Memory module on page 36](#))
- Solid-state drive (if installed) (see [Solid-state drive on page 37](#))
- Heat sink assembly (see [Heat sink assembly on page 48](#))

To remove the system board:

1. Position the computer upright, and then disconnect the following cables from the system board:
 - (1) USB board cable
 - (2) WLAN antenna cables
 - (3) Fingerprint reader cable
 - (4) Touchpad button board cable
 - (5) Keyboard cable
 - (6) Backlight cable
 - (7) Hard drive cable
 - (8) Power connector cable
 - (9) Display cable

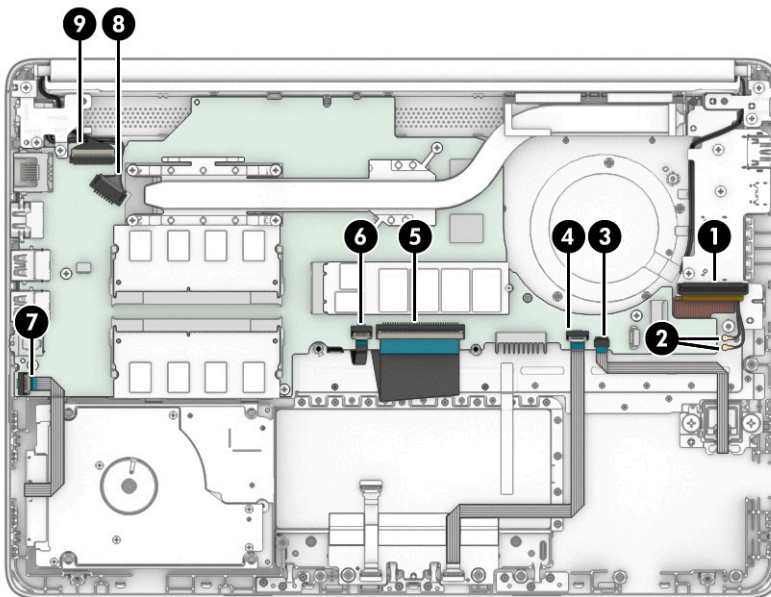

2. Remove the Phillips M2.0 × 3.0 screw **(1)** that secures the system board to the computer.
3. Remove the three Phillips M2.0 × 2.0 screws **(2)** that secure the system board to the computer.
4. Remove the two Phillips M2.5 × 6.0 screws **(3)** and the Phillips M2.5 × 3.0 screw **(4)** from the right display hinge.
5. Rotate the right display hinge to the upright position **(5)**.

6. Lift the system board out of the computer (6).

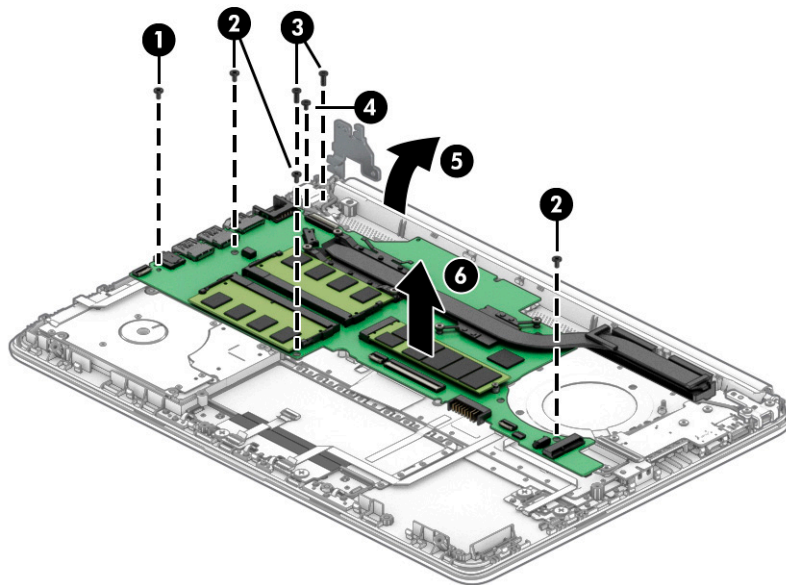

Reverse this procedure to install the system board.

Heat sink assembly

 **NOTE:** The heat sink assembly spare part kit includes replacement thermal materials.

Table 5-16 Heat sink descriptions and part numbers

Description	Spare part number
Heat sink assembly, discrete (includes replacement thermal materials)	L23192-001
Heat sink assembly, UMA (includes replacement thermal materials)	L23191-001

Before removing the heat sink assembly, follow these steps:

1. Prepare the computer for disassembly ([Preparation for disassembly on page 27](#)).
2. Remove the rubber feet (see [Computer feet on page 27](#)).
3. Remove the bottom cover (see [Bottom cover on page 29](#)).
4. Remove the battery (see [Battery on page 31](#)).

To remove the heat sink assembly:

1. If you have a model with discrete graphics:
 - a. In the order indicated on the heat sink, remove the six Phillips M2.0 × 4.0 screws (**1**) that secure the heat sink to the system board.
 - b. Remove the heat sink (**2**) from the system board.

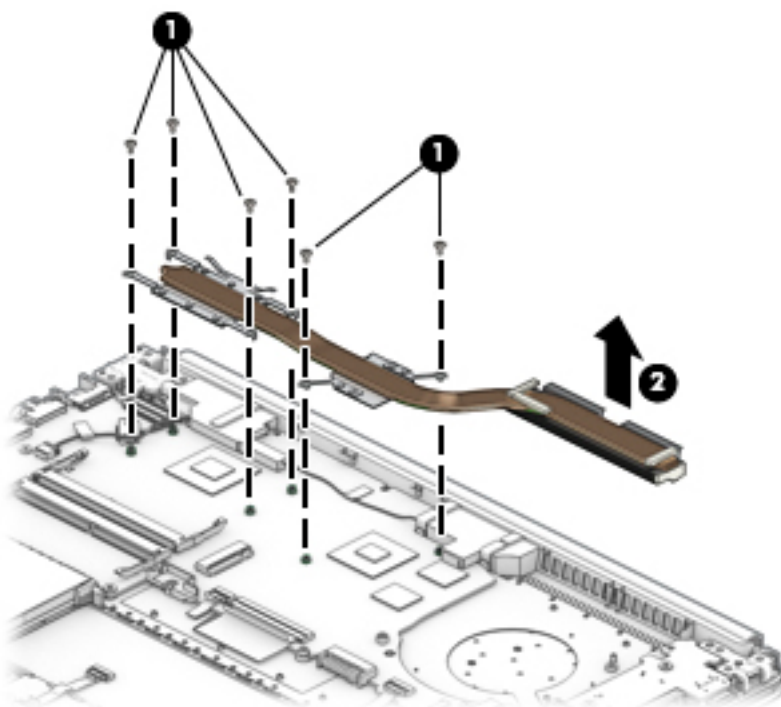

2. If you have a model with UMA graphics:
 - a. In the order indicated on the heat sink, remove the four Phillips M2.0 × 4.0 screws (**1**) that secure the heat sink to the system board.

- b. Remove the heat sink (2) from the system board.

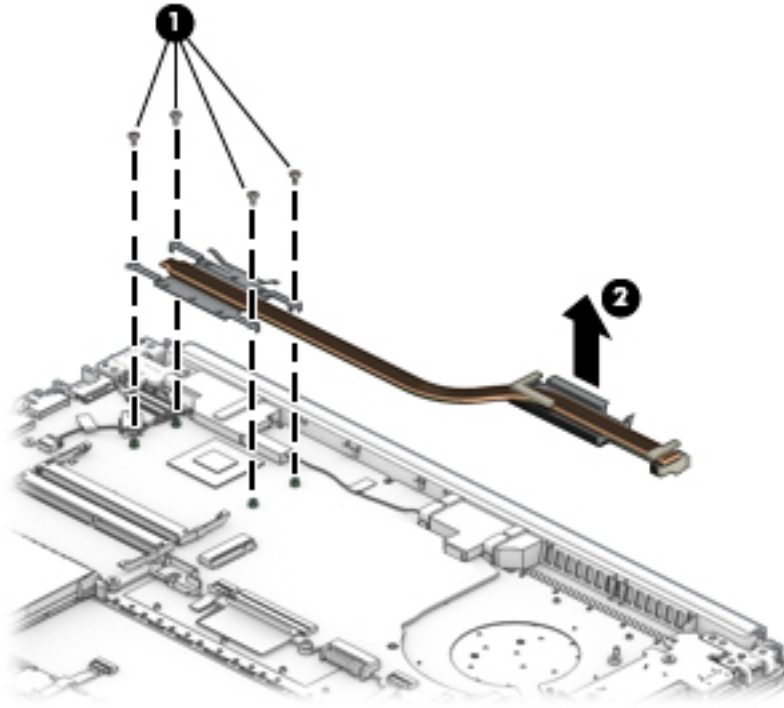

 **NOTE:** Thoroughly clean the thermal material from the surfaces of the heat sink and the system board components each time the heat sink is removed. Replacement thermal material is included with the heat sink, processor, and system board spare part kits.

The following illustrations show replacement thermal material locations.

- **Discrete graphics:** Thermal paste is used on the heat sink (2) (4) and associated system board components (1) (3).

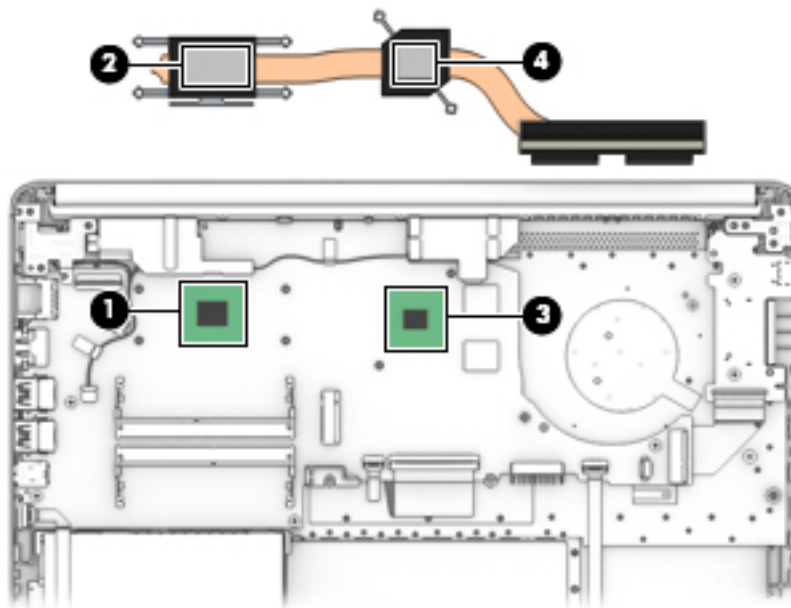

- **UMA graphics:** Thermal paste is used on the heat sink **(2)** and associated system board component **(1)**.

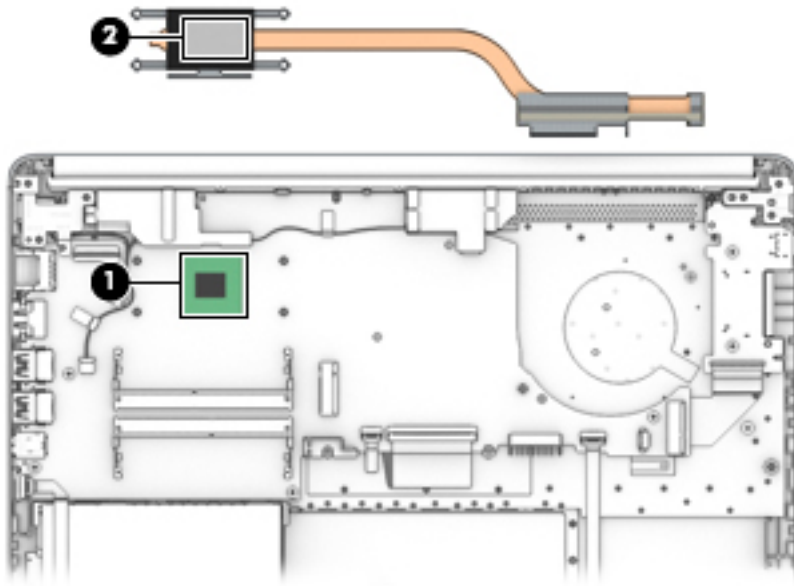

Reverse this procedure to reassemble and install the heat sink assembly.

Display assembly

Before removing the display assembly, follow these steps:

1. Prepare the computer for disassembly ([Preparation for disassembly on page 27](#)).
2. Remove the rubber feet (see [Computer feet on page 27](#)).
3. Remove the bottom cover (see [Bottom cover on page 29](#)).
4. Remove the battery (see [Battery on page 31](#)).

To remove the display assembly:

1. Disconnect the display cable from the system board **(1)**.
2. Remove the wireless antenna cables from their routing path under the USB board cable **(2)** and between the fan and USB board and to the display **(3)**.

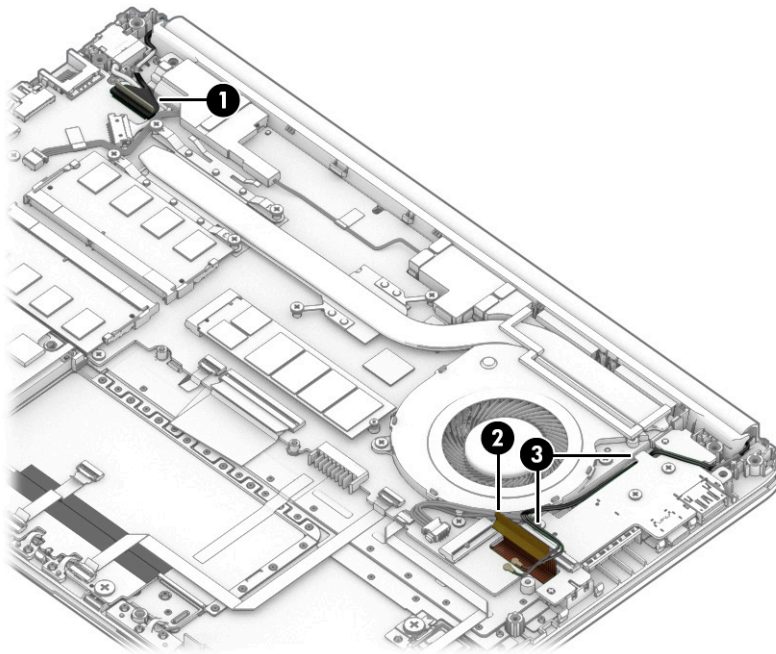

3. Position the computer so it is open with the display hanging off the table **(1)**.
4. Remove the four Phillips M2.5 × 6.0 screws **(2)** from the display hinges.
5. Remove the Phillips M2.5 × 3.0 screw **(3)** from the display hinges.

6. Rotate the hinges upward to an angle (4), and then remove the display (5).

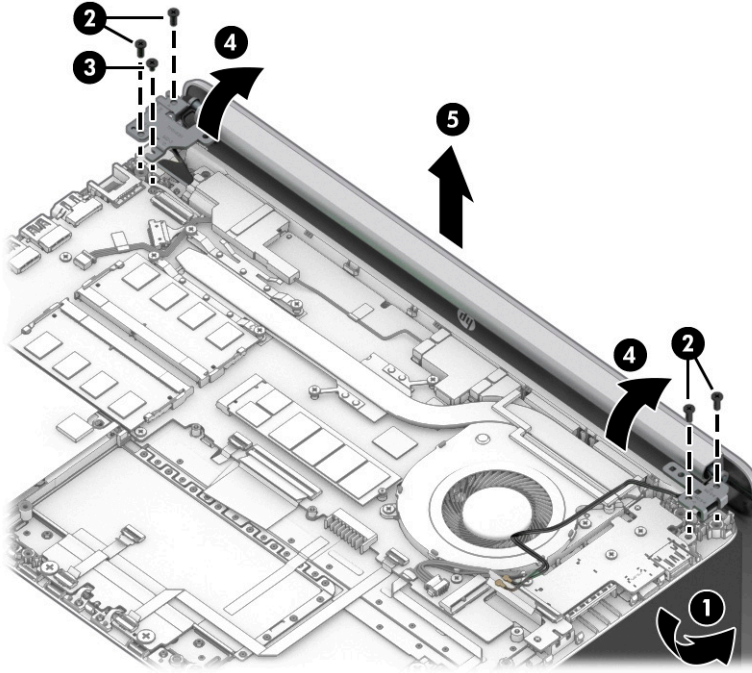

If it is necessary to replace any of the display assembly subcomponents:

1. Lift the hinge cap to remove it from display.

The hinge cap is available as spare part numbers L58455-001 for pike silver models and L58454-001 for stone silver models.

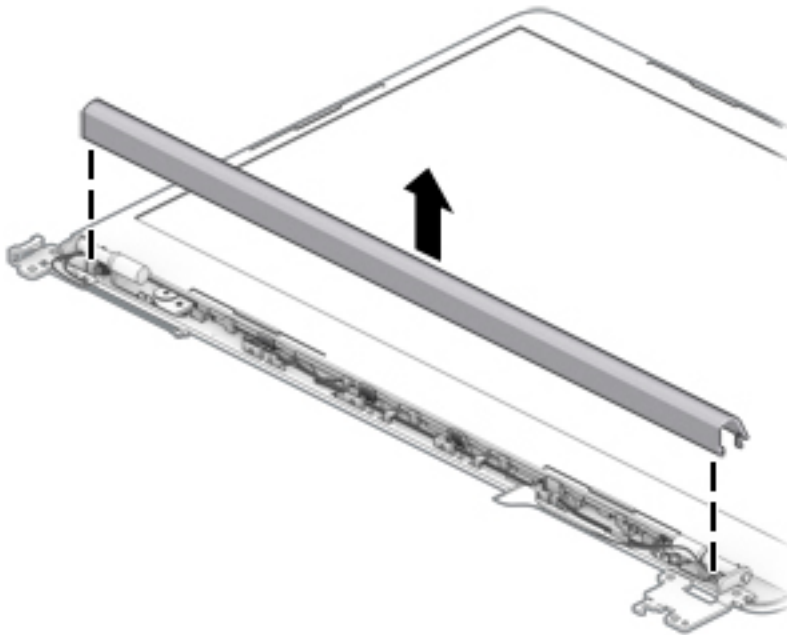

2. Flex the inside of the top edge (1), left and right sides (2), and the inside of the bottom edge (3) of the display bezel until the bezel disengages from the display enclosure.

3. Remove the display bezel (4).

The display bezel is available as spare part numbers L56980-001 for models without a webcam and L56981-001 for models with a webcam.

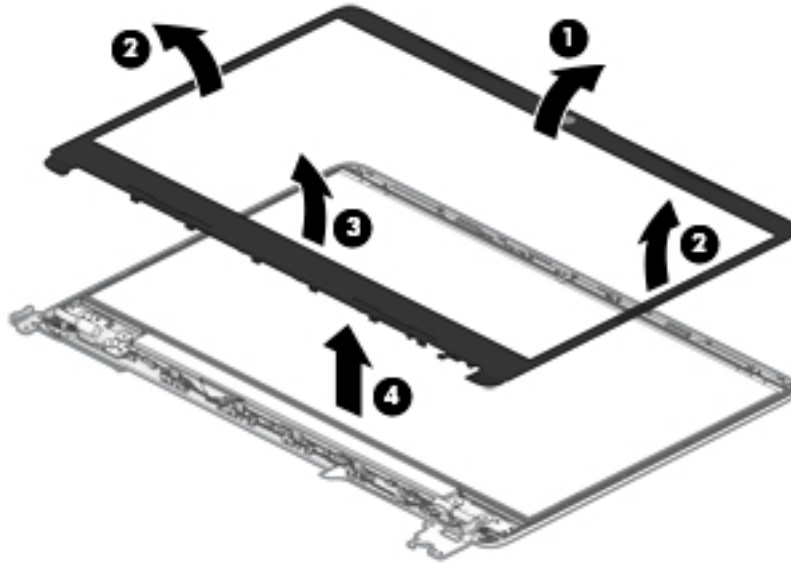

4. To remove the webcam/microphone module:

- a.** Position the display assembly with the top edge toward you.
- b.** Lift the webcam module to disengage the adhesive that secures the module to the display (1).
- c.** Disconnect the cable (2) from the module.

The webcam module is available as spare part number L56987-001.

The microphone module is available as spare part number L56984-001.

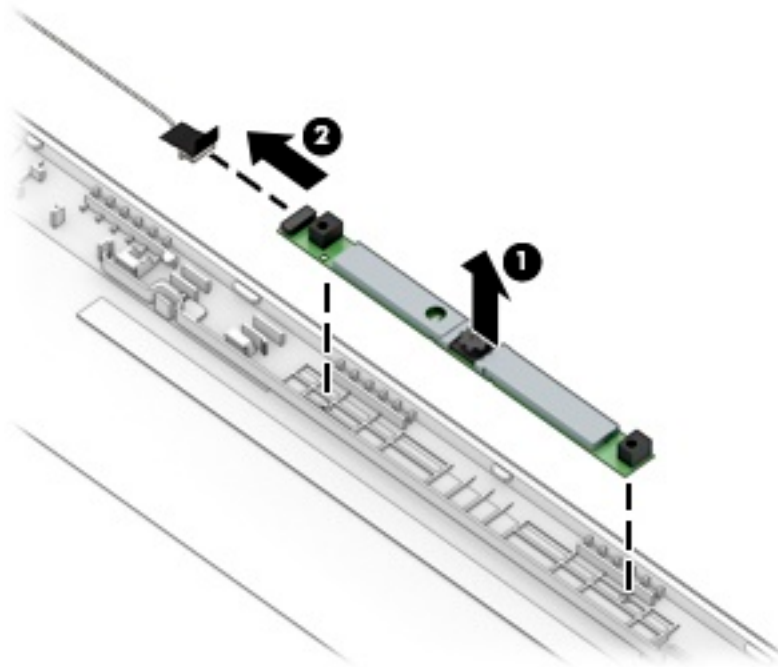

5. To remove the display panel:

- a. The display panel is secured to the display enclosure with tape that is installed under the left and right sides of the panel. Use tweezers to grasp the end of the tape (1) near the bottom corners of the display panel. Pull the tape out from under the right (2) and left (3) corners of the display panel until it is completely removed. Lift the top of the panel (4).

 **TIP:** To avoid tearing the tape, it might help to turn and wrap the tape around the tweezers as you pull the tape out from behind the display panel. You must pull the tape multiple times before it is completely removed.

 **IMPORTANT:** If the tape tears, do not attempt to pry the panel off the enclosure. Doing so might break the panel.

The ends of the tape are accessible at both the top and bottom of the display panel.

To avoid tearing the tape, do not pull on it with the sharp end of tweezers.

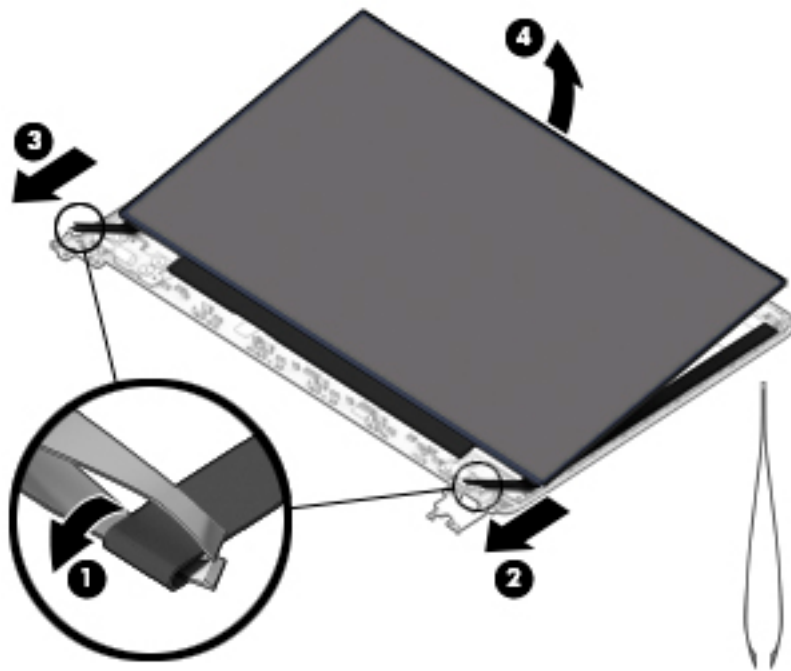

- b. Rotate the display panel onto the keyboard (1) to gain access to the display cable connection on the back of the panel.
- c. On the back of the display panel, release the adhesive strip that secures the display panel cable to the display panel, and then disconnect the cable (2).

- d. Remove the display panel from the display enclosure **(3)**.

The display panel is available as spare part numbers L56982-001 for FHD UWVA panels and L56983-001 for HD SVA panels.

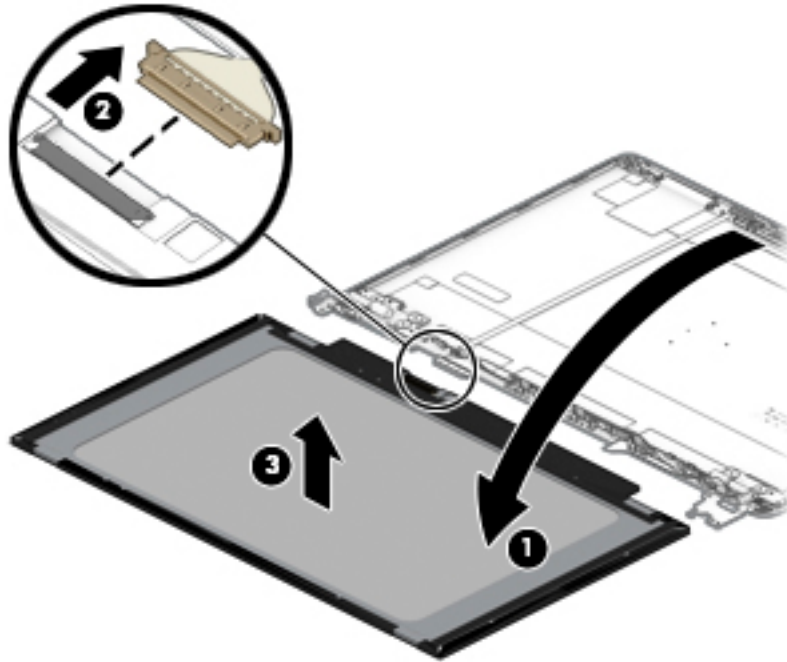

6. To remove the display hinges:

- a. Remove the three Phillips M2.5 × 2.5 screws **(1)** from the bottom of each hinge.
- b. Remove the display hinges from the enclosure **(2)**.

The display hinges are available as spare part number L24470-001.

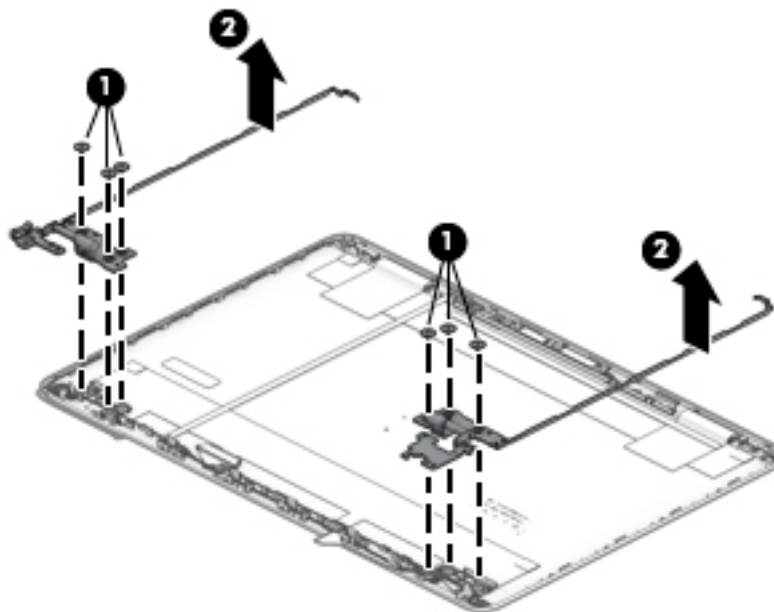

7. To remove the display/webcam cable, lift the tape from atop the connector on the webcam module **(1)**, and then disconnect the cable from the webcam module **(2)**. Lift the cable from the display enclosure to disengage the adhesive that secures it **(3)**.

The display/webcam cable is available as spare part number L24492-001 for models with HD panels and L24493-001 for models with FHD panels.

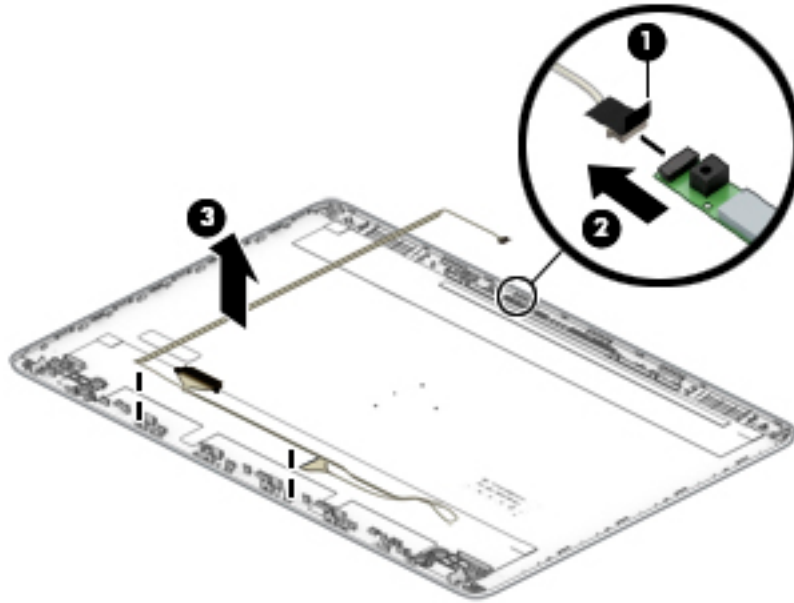

8. To remove the wireless antennas and cables, release the wireless antenna cables from the clips **(1)** built into the side of the display enclosure, and then peel the antennas of the display enclosure **(2)** to remove the antennas and cables.

 **NOTE:** Number of antennas and transceivers may vary.

The antenna cables are available as spare part number L24640-001 for models with dual antennas and L29012-001 for models with a single antenna.

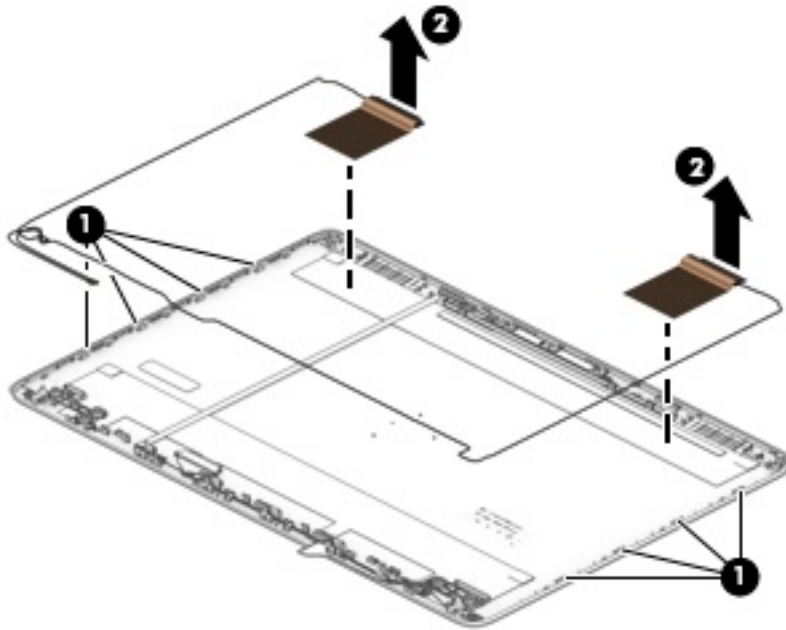

9. If replacing the display enclosure, be sure that the subcomponents (including the webcam/microphone module, the antenna receivers, and all associated cables and hardware) are transferred to the new enclosure.

The display enclosure is available as spare part number L56978-001 for pike silver models and L56979-001 for stone silver models.

Reverse this procedure to reassemble and install the display assembly.

Top cover/keyboard

The top cover/keyboard spare part remains after all other spare parts have been removed.

The first table provides the main spare part number for the keyboard. The second table provides the country codes.

Table 5-17 Top cover/keyboard descriptions and part numbers

Description	Spare part number
Top cover/keyboard, pike silver	L81308-xx1
Top cover/keyboard, stone silver	L81309-xx1

Table 5-18 Keyboard country codes

For use in country or region	Spare part number	For use in country or region	Spare part number
India	-D61	Thailand	-281
Latin America	-161	United States	-001
Taiwan	-AB1		

6 Computer Setup (BIOS), TPM, and HP Sure Start

Using Computer Setup

Computer Setup, or Basic Input/Output System (BIOS), controls communication between all the input and output devices on the system (such as disk drives, display, keyboard, mouse, and printer). Computer Setup includes settings for the types of devices installed, the startup sequence of the computer, and the amount of system and extended memory.

 **NOTE:** Use extreme care when making changes in Computer Setup. Errors can prevent the computer from operating properly.

Starting Computer Setup

- ▲ Turn on or restart the computer, and when the HP logo appears, press **f10** to enter Computer Setup.

Navigating and selecting in Computer Setup

- To select a menu or a menu item, use the **tab** key and the keyboard arrow keys and then press **enter**, or use a pointing device to select the item.
- To scroll up and down, select the up arrow or the down arrow in the upper-right corner of the screen, or use the up arrow key or the down arrow key on the keyboard.
- To close open dialog boxes and return to the main Computer Setup screen, press **esc**, and then follow the on-screen instructions.

To exit Computer Setup, choose one of the following methods:

- To exit Computer Setup menus without saving your changes, select **Main**, select **Ignore Changes and Exit**, and then select **Yes**.

 **NOTE:** If you are using arrow keys to highlight your choice, you must then press **enter**.

- To save your changes and exit Computer Setup menus, select **Main**, select **Save Changes and Exit**, and then select **Yes**.

 **NOTE:** If you are using arrow keys to highlight your choice, you must then press **enter**.

Your changes go into effect when the computer restarts.

Restoring factory settings in Computer Setup

 **NOTE:** Restoring defaults will not change the hard drive mode.

To return all settings in Computer Setup to the values that were set at the factory, follow these steps:

1. Start Computer Setup. See [Starting Computer Setup on page 59](#).
2. Select **Main**, select **Apply Factory Defaults and Exit**, and then select **Yes**.

 **NOTE:** If you are using arrow keys to highlight your choice, you must then press **enter**.

 **NOTE:** On select products, the selections might display **Restore Defaults** instead of **Apply Factory Defaults and Exit**.

Your changes go into effect when the computer restarts.

 **NOTE:** Your password settings and security settings are not changed when you restore the factory settings.

Updating the BIOS

Updated versions of the BIOS might be available on the HP website.

Most BIOS updates on the HP website are packaged in compressed files called *SoftPaqs*.

Some download packages contain a file named *Readme.txt*, which contains information regarding installing and troubleshooting the file.

Determining the BIOS version

To decide whether you need to update Computer Setup (BIOS), first determine the BIOS version on your computer.

You can access BIOS version information (also known as *ROM date* and *System BIOS*) by pressing **fn+esc** (if you are already in Windows) or by using Computer Setup.

1. Start Computer Setup. See [Starting Computer Setup on page 59](#).
2. Select **Main**, and then select **System Information**.
3. To exit Computer Setup menus without saving your changes, select **Main**, select **Ignore Changes and Exit**, and then select **Yes**.

 **NOTE:** If you are using arrow keys to highlight your choice, you must then press **enter**.

To check for later BIOS versions, see [Downloading a BIOS update on page 60](#).

Downloading a BIOS update

 **IMPORTANT:** To reduce the risk of damage to the computer or an unsuccessful installation, download and install a BIOS update only when the computer is connected to reliable external power using the AC adapter. Do not download or install a BIOS update while the computer is running on battery power, docked in an optional docking device, or connected to an optional power source. During the download and installation, follow these instructions:

Do not disconnect power on the computer by unplugging the power cord from the AC outlet.

Do not shut down the computer or initiate Sleep.

Do not insert, remove, connect, or disconnect any device, cable, or cord.

1. Type `support` in the taskbar search box, and then select the HP Support Assistant app.
– or –
Select the question mark icon in the taskbar.
2. Select **Updates**, and then select **Check for updates and messages**.
3. Follow the on-screen instructions.
4. At the download area, follow these steps:

- a. Identify the most recent BIOS update and compare it to the BIOS version currently installed on your computer. Make a note of the date, name, or other identifier. You might need this information to locate the update later, after it has been downloaded to your hard drive.
- b. Follow the on-screen instructions to download your selection to the hard drive.

Make a note of the path to the location on your hard drive where the BIOS update is downloaded. You will need to access this path when you are ready to install the update.

 **NOTE:** If you connect your computer to a network, consult the network administrator before installing any software updates, especially system BIOS updates.

BIOS installation procedures vary. Follow any instructions that are displayed on the screen after the download is complete. If no instructions are displayed, follow these steps:

1. Type `file` in the taskbar search box, and then select **File Explorer**.
2. Select your hard drive designation. The hard drive designation is typically Local Disk (C:).
3. Using the hard drive path you recorded earlier, open the folder that contains the update.
4. Double-click the file that has an `.exe` extension (for example, `filename.exe`).

The BIOS installation begins.

5. Complete the installation by following the on-screen instructions.

 **NOTE:** After a message on the screen reports a successful installation, you can delete the downloaded file from your hard drive.

Changing the boot order using the f9 prompt

To dynamically choose a boot device for the current startup sequence, follow these steps:

1. Access the Boot Device Options menu:
 - Turn on or restart the computer, and when the HP logo appears, press **f9** to enter the Boot Device Options menu.
2. Select a boot device, press **enter**, and then follow the on-screen instructions.

TPM BIOS settings (select products only)

 **IMPORTANT:** Before enabling Trusted Platform Module (TPM) functionality on this system, you must ensure that your intended use of TPM complies with relevant local laws, regulations and policies, and approvals or licenses must be obtained if applicable. For any compliance issues arising from your operation or usage of TPM that violates the previously mentioned requirement, you shall bear all the liabilities wholly and solely. HP will not be responsible for any related liabilities.

TPM provides additional security for your computer. You can modify the TPM settings in Computer Setup (BIOS).

 **NOTE:** If you change the TPM setting to Hidden, TPM is not visible in the operating system.

To access TPM settings in Computer Setup:

1. Start Computer Setup. See [Starting Computer Setup on page 59](#).
2. Select **Security**, select **TPM Embedded Security**, and then follow the on-screen instructions.

Using HP Sure Start (select products only)

Select computer models are configured with HP Sure Start, a technology that monitors the computer's BIOS for attacks or corruption. If the BIOS becomes corrupted or is attacked, HP Sure Start automatically restores the BIOS to its previously safe state, without user intervention.

HP Sure Start is configured and already enabled so that most users can use the HP Sure Start default configuration. Advanced users can customize the default configuration.

To access the latest documentation on HP Sure Start, go to <http://www.hp.com/support>. Select **Find your product**, and then follow the on-screen instructions.

7 Backing up, restoring, and recovering

This chapter provides information about the following processes, which are standard procedure for most products:

- **Backing up your personal information**—You can use Windows tools to back up your personal information (see [Using Windows tools on page 63](#)).
- **Creating a restore point**—You can use Windows tools to create a restore point (see [Using Windows tools on page 63](#)).
- **Creating recovery media** (select products only)—You can use the HP Cloud Recovery Download Tool (select products only) to create recovery media (see [Using the HP Cloud Recovery Download Tool to create recovery media \(select products only\) on page 63](#)).
- **Restoring and recovery**—Windows offers several options for restoring from backup, refreshing the computer, and resetting the computer to its original state (see [Using Windows tools on page 63](#)).

 **IMPORTANT:** If you will be performing recovery procedures on a tablet, the tablet battery must be at least 70% charged before you start the recovery process.

IMPORTANT: For a tablet with a detachable keyboard, connect the tablet to the keyboard base before beginning any recovery process.

Backing up information and creating recovery media

Using Windows tools

 **IMPORTANT:** Windows is the only option that allows you to back up your personal information. Schedule regular backups to avoid information loss.

You can use Windows tools to back up personal information and create system restore points and recovery media.

 **NOTE:** If computer storage is 32 GB or less, Microsoft System Restore is disabled by default.

For more information and steps, see the Get Help app.

1. Select the **Start** button, and then select the **Get Help** app.
2. Enter the task you want to perform.

 **NOTE:** You must be connected to the Internet to access the Get Help app.

Using the HP Cloud Recovery Download Tool to create recovery media (select products only)

You can use the HP Cloud Recovery Download Tool to create HP Recovery media on a bootable USB flash drive.

For details:

- ▲ Go to <http://www.hp.com/support>, search for HP Cloud Recovery, and then select the result that matches the type of computer that you have.



NOTE: If you cannot create recovery media yourself, contact support to obtain recovery discs. Go to <http://www.hp.com/support>, select your country or region, and then follow the on-screen instructions.

Restoring and recovery

Restoring, resetting, and refreshing using Windows tools

Windows offers several options for restoring, resetting, and refreshing the computer. For details, see [Using Windows tools on page 63](#).

Recovering using HP Recovery media

You can use HP Recovery media to recover the original operating system and software programs that were installed at the factory. On select products, it can be created on a bootable USB flash drive using the HP Cloud Recovery Download Tool. For details, see [Using the HP Cloud Recovery Download Tool to create recovery media \(select products only\) on page 63](#).



NOTE: If you cannot create recovery media yourself, contact support to obtain recovery discs. Go to <http://www.hp.com/support>, select your country or region, and then follow the on-screen instructions.

To recover your system:

- ▲ Insert the HP Recovery media, and then restart the computer.

Changing the computer boot order

If your computer does not restart using the HP Recovery media, you can change the computer boot order. This is the order of devices listed in BIOS where the computer looks for startup information. You can change the selection to an optical drive or a USB flash drive, depending on the location of your HP Recovery media.

To change the boot order:



IMPORTANT: For a tablet with a detachable keyboard, connect the tablet to the keyboard base before beginning these steps.

1. Insert the HP Recovery media.
2. Access the system **Startup** menu.

For computers or tablets with keyboards attached:

- ▲ Turn on or restart the computer or tablet, quickly press **esc**, and then press **f9** for boot options.

For tablets without keyboards:

- ▲ Turn on or restart the tablet, quickly hold down the volume up button, and then select **f9**.

– or –

Turn on or restart the tablet, quickly hold down the volume down button, and then select **f9**.

3. Select the optical drive or USB flash drive from which you want to boot, and then follow the on-screen instructions.

Using HP Sure Recover (select products only)

Select computer models are configured with HP Sure Recover, a PC OS recovery solution built into the hardware and firmware. HP Sure Recover can fully restore the HP OS image without installed recovery software.

Using HP Sure Recover, an administrator or user can restore the system and install:

- Latest version of the operating system
- Platform-specific device drivers
- Software applications, in the case of a custom image

To access the latest documentation for HP Sure Recover, go to <http://www.hp.com/support>. Select **Find your product**, and then follow the on-screen instructions.

8 Using HP PC Hardware Diagnostics

Using HP PC Hardware Diagnostics Windows (select products only)

HP PC Hardware Diagnostics Windows is a Windows-based utility that allows you to run diagnostic tests to determine whether the computer hardware is functioning properly. The tool runs within the Windows operating system to diagnose hardware failures.

If HP PC Hardware Diagnostics Windows is not installed on your computer, first you must download and install it. To download HP PC Hardware Diagnostics Windows, see [Downloading HP PC Hardware Diagnostics Windows on page 67](#).

After HP PC Hardware Diagnostics Windows is installed, follow these steps to access it from HP Help and Support or HP Support Assistant.

1. To access HP PC Hardware Diagnostics Windows from HP Help and Support:

- a. Select the **Start** button, and then select **HP Help and Support**.
- b. Select **HP PC Hardware Diagnostics Windows**.

– or –

To access HP PC Hardware Diagnostics Windows from HP Support Assistant:

- a. Type `support` in the taskbar search box, and then select the **HP Support Assistant** app.

– or –

Select the question mark icon in the taskbar.

- b. Select **Troubleshooting and fixes**.
- c. Select **Diagnostics**, and then select **HP PC Hardware Diagnostics Windows**.

2. When the tool opens, select the type of diagnostic test that you want to run, and then follow the on-screen instructions.



NOTE: To stop a diagnostic test, select **Cancel**.

When HP PC Hardware Diagnostics Windows detects a failure that requires hardware replacement, a 24-digit Failure ID code is generated. The screen displays one of the following options:

- A Failure ID link is displayed. Select the link and follow the on-screen instructions.
- Instructions for calling support are displayed. Follow those instructions.

Downloading HP PC Hardware Diagnostics Windows

- The HP PC Hardware Diagnostics Windows downloading instructions are provided in English only.
- You must use a Windows computer to download this tool because only .exe files are provided.

Downloading the latest HP PC Hardware Diagnostics Windows version

To download HP PC Hardware Diagnostics Windows, follow these steps:

1. Go to <http://www.hp.com/go/techcenter/pcdiags>. The HP PC Diagnostics home page is displayed.
2. Select **Download HP Diagnostics Windows**, and then select a location on your computer or a USB flash drive.

The tool downloads to the selected location.

– or –

You can use the following steps to download the HP PC Hardware Diagnostics Windows from the Microsoft Store:

1. Select the Microsoft app on your desktop or enter `Microsoft Store` in the taskbar search box.
2. Enter `HP PC Hardware Diagnostics Windows` in the **Microsoft Store** search box.
3. Follow the on-screen directions.

The tool downloads to the selected location.

Downloading HP Hardware Diagnostics Windows by product name or number (select products only)



NOTE: For some products, you might have to download the software to a USB flash drive by using the product name or number.

To download HP PC Hardware Diagnostics Windows by product name or number, follow these steps:

1. Go to <http://www.hp.com/support>.
2. Select **Get software and drivers**, select your type of product, and then enter the product name or number in the search box that is displayed.
3. In the **Diagnostics** section, select **Download**, and then follow the on-screen instructions to select the specific Windows diagnostics version to be downloaded to your computer or USB flash drive.

The tool downloads to the selected location.

Installing HP PC Hardware Diagnostics Windows

To install HP PC Hardware Diagnostics Windows, follow these steps:

- ▲ Navigate to the folder on your computer or the USB flash drive where the .exe file downloaded, double-click the .exe file, and then follow the on-screen instructions.

Using HP PC Hardware Diagnostics UEFI



NOTE: For Windows 10 S computers, you must use a Windows computer and a USB flash drive to download and create the HP UEFI support environment because only .exe files are provided. For more information, see [Downloading HP PC Hardware Diagnostics UEFI to a USB flash drive on page 69](#).

HP PC Hardware Diagnostics UEFI (Unified Extensible Firmware Interface) allows you to run diagnostic tests to determine whether the computer hardware is functioning properly. The tool runs outside the operating system so that it can isolate hardware failures from issues that are caused by the operating system or other software components.

If your PC does not start in Windows, you can use HP PC Hardware Diagnostics UEFI to diagnose hardware issues.

When HP PC Hardware Diagnostics UEFI detects a failure that requires hardware replacement, a 24-digit Failure ID code is generated. For assistance in solving the problem:

- ▲ Select **Contact HP**, accept the HP privacy disclaimer, and then use a mobile device to scan the Failure ID code that appears on the next screen. The HP Customer Support - Service Center page appears with your Failure ID and product number automatically filled in. Follow the on-screen instructions.
- or –
- Contact support, and provide the Failure ID code.

 **NOTE:** To start diagnostics on a convertible computer, your computer must be in notebook mode, and you must use the attached keyboard.

 **NOTE:** If you need to stop a diagnostic test, press *esc*.

Starting HP PC Hardware Diagnostics UEFI

To start HP PC Hardware Diagnostics UEFI, follow these steps:

1. Turn on or restart the computer, and quickly press *esc*.
2. Press *f2*.

The BIOS searches three places for the diagnostic tools, in the following order:

- a. Connected USB flash drive
 -  **NOTE:** To download the HP PC Hardware Diagnostics UEFI tool to a USB flash drive, see [Downloading the latest HP PC Hardware Diagnostics UEFI version on page 69](#).
 - b. Hard drive
 - c. BIOS
3. When the diagnostic tool opens, select a language, select the type of diagnostic test you want to run, and then follow the on-screen instructions.

Downloading HP PC Hardware Diagnostics UEFI to a USB flash drive

Downloading HP PC Hardware Diagnostics UEFI to a USB flash drive can be useful in the following situations:

- HP PC Hardware Diagnostics UEFI is not included in the preinstallation image.
- HP PC Hardware Diagnostics UEFI is not included in the HP Tool partition.
- The hard drive is damaged.

 **NOTE:** The HP PC Hardware Diagnostics UEFI downloading instructions are provided in English only, and you must use a Windows computer to download and create the HP UEFI support environment because only .exe files are provided.

Downloading the latest HP PC Hardware Diagnostics UEFI version

To download the latest HP PC Hardware Diagnostics UEFI version to a USB flash drive:

1. Go to <http://www.hp.com/go/techcenter/pcdiags>. The HP PC Diagnostics home page is displayed.
2. Select **Download HP Diagnostics UEFI**, and then select **Run**.

Downloading HP PC Hardware Diagnostics UEFI by product name or number (select products only)



NOTE: For some products, you might have to download the software to a USB flash drive by using the product name or number.

To download HP PC Hardware Diagnostics UEFI by product name or number (select products only) to a USB flash drive:

1. Go to <http://www.hp.com/support>.
2. Enter the product name or number, select your computer, and then select your operating system.
3. In the **Diagnostics** section, follow the on-screen instructions to select and download the specific UEFI Diagnostics version for your computer.

Using Remote HP PC Hardware Diagnostics UEFI settings (select products only)

Remote HP PC Hardware Diagnostics UEFI is a firmware (BIOS) feature that downloads HP PC Hardware Diagnostics UEFI to your computer. It can then execute the diagnostics on your computer, and it might upload results to a preconfigured server. For more information about Remote HP PC Hardware Diagnostics UEFI, go to <http://www.hp.com/go/techcenter/pcdiags>, and then select **Find out more**.

Downloading Remote HP PC Hardware Diagnostics UEFI



NOTE: HP Remote PC Hardware Diagnostics UEFI is also available as a SoftPaq that you can download to a server.

Downloading the latest Remote HP PC Hardware Diagnostics UEFI version

To download the latest Remote HP PC Hardware Diagnostics UEFI version, follow these steps:

1. Go to <http://www.hp.com/go/techcenter/pcdiags>. The HP PC Diagnostics home page is displayed.
2. Select **Download Remote Diagnostics**, and then select **Run**.

Downloading Remote HP PC Hardware Diagnostics UEFI by product name or number



NOTE: For some products, you might have to download the software by using the product name or number.

To download HP Remote PC Hardware Diagnostics UEFI by product name or number, follow these steps:

1. Go to <http://www.hp.com/support>.
2. Select **Get software and drivers**, select your type of product, enter the product name or number in the search box that is displayed, select your computer, and then select your operating system.
3. In the **Diagnostics** section, follow the on-screen instructions to select and download the **Remote UEFI** version for the product.

Customizing Remote HP PC Hardware Diagnostics UEFI settings

Using the Remote HP PC Hardware Diagnostics setting in Computer Setup (BIOS), you can perform the following customizations:

- Set a schedule for running diagnostics unattended. You can also start diagnostics immediately in interactive mode by selecting **Execute Remote HP PC Hardware Diagnostics**.
- Set the location for downloading the diagnostic tools. This feature provides access to the tools from the HP website or from a server that has been preconfigured for use. Your computer does not require the traditional local storage (such as a hard drive or USB flash drive) to run remote diagnostics.
- Set a location for storing the test results. You can also set the user name and password that you use for uploads.
- Display status information about the diagnostics run previously.

To customize Remote HP PC Hardware Diagnostics UEFI settings, follow these steps:

1. Turn on or restart the computer, and when the HP logo appears, press **f10** to enter Computer Setup.
2. Select **Advanced**, and then select **Settings**.
3. Make your customization selections.
4. Select **Main**, and then **Save Changes and Exit** to save your settings.

Your changes take effect when the computer restarts.

9 Specifications

Computer specifications

Table 9-1 Computer specifications

	Metric	U.S.
Dimensions		
Depth	324.0 mm	12.76 in
Width	225.9 mm	8.9 in
Height (rear)	19.9 mm	0.78 in
Weight		
	1.5 kg	3.3 lb
Input power		
Operating voltage and current	19.5 V dc @ 2.31 A – 45 W 19.5 V dc @ 3.33 A – 65 W	
Temperature		
Operating	5°C to 35°C	41°F to 95°F
Nonoperating	-20°C to 60°C	-4°F to 140°F
Relative humidity (noncondensing)		
Operating	10% to 90%	
Nonoperating	5% to 95%	
Maximum altitude (unpressurized)		
Operating	-15 m to 3,048 m	-50 ft to 10,000 ft
Nonoperating	-15 m to 12,192 m	-50 ft to 40,000 ft

NOTE: Applicable product safety standards specify thermal limits for plastic surfaces. The device operates well within this range of temperatures.

35.6 cm (14.0 in) display specifications

Table 9-2 Display specifications

	Metric	U.S.
Active diagonal size	35.6 cm	14.0 in
Thickness	3.0 mm	0.118 in
Resolution	1920 × 1080 (FHD panel) 1366 × 768 (HD panel)	
Surface treatment	Antiglare	
Brightness	220 nits (HD panel) 250 nits (FHD panel)	
Viewing angle	SVA (HD panel) UWVA (FHD panel)	
Backlight	WLED	
Graphics adapter	eDP	

Hard drive specifications

Table 9-3 Hard drive specifications

	1-TB*	500-GB*
Dimensions		
Height	7.2 mm or 9.5 mm	7.2 mm
Length	100.4 mm	100.6 mm
Width	69.9 mm	70.1 mm
Weight	115.0 g	92.0 g
Interface type	SATA	SATA
Transfer rate		
Synchronous (maximum)	300 MB/s	300 MB/s
Security	ATA security	ATA security
Seek times (typical read, including setting)		
Single track	1.4 ms	3 ms
Average (read/write)	10 ms	13 ms
Maximum	12 ms	24 ms
Logical blocks	1,938,921,461	1,048,576,000
Disk rotational speed	5400 rpm	5400 rpm
Operating temperature	0°C to 60°C (32°F to 140°F)	
*1 GB = 1 billion bytes when referring to hard drive storage capacity. Actual accessible capacity is less.		
NOTE: Certain restrictions and exclusions apply. Contact technical support for details.		

PCIe solid-state drive specifications

	256 GB*	512 GB*
Dimensions		
Height	1 mm	1 mm
Length	50.8 mm	50.8 mm
Width	28.9 mm	28.9 mm
Weight	< 10 g	< 10 g
Interface type		
	ATA-7	ATA-7
Transfer rate		
Sequential Read	Up to 2150 MB/s	Up to 2150 MB/s
Random Read	Up to 300,000 IOPs	Up to 300,000 IOPs
Sequential Write	Up to 1260 MB/s	Up to 1550 MB/s
Random Write	Up to 100,000 IOPs	Up to 100,000 IOPs
Ready time, Maximum (to not busy)		
	1.0 s	1.0 s
Access times		
Logical	0.1	0.1
Total logical sectors		
	500,118,192	1,000,215,216
Operating temperature		
Operating	0° to 70°C (32°F to 158°F)	0° to 70°C (32°F to 158°F)
Nonoperating	-40° to 80°C (-40°F to 176°F)	-40° to 85°C (-40°F to 185°F)
*1 GB = 1 billion bytes when referring to hard drive storage capacity. Actual accessible capacity is less.		
NOTE: Certain restrictions and exclusions apply. Contact technical support for details.		

SATA solid-state drive specifications

Table 9-4 Solid-state drive specifications

	128-GB*	256-GB*
Dimensions		
Height	1 mm	1 mm
Length	50.8 mm	50.8 mm
Width	28.9 mm	28.9 mm
Weight	< 10 g	< 10 g
Interface type	SATA-3 (6 Gbps)	SATA-3 (6 Gbps)
Transfer rate		
Sequential Read	Up to 520 MB/s	Up to 540 MB/s
Random Read	Up to 60K IOPs	Up to 85K IOPs
Sequential Write	Up to 160 MB/s	Up to 280 MB/s
Random Write	Up to 34K IOPs	Up to 67K IOPs
Ready time, maximum	1.0 s	1.0 s
Access times		
Logical	0.1 ms	0.1
Total logical sectors	250,069,680	500,118,192
Operating temperature		
Operating	0° to 70°C (32°F to 158°F)	0° to 70°C (32°F to 158°F)
Nonoperating	-40° to 95°C (-40°F to 203°F)	-55° to 90°C (-67°F to 194°F)
*1 GB = 1 billion bytes when referring to hard drive storage capacity. Actual accessible capacity is less.		
NOTE: Certain restrictions and exclusions apply. Contact technical support for details.		

10 Power cord set requirements

The wide-range input feature of the computer permits it to operate from any line voltage from 100 to 120 V ac, or from 220 to 240 V ac.

The 3-conductor power cord set included with the computer meets the requirements for use in the country or region where the equipment is purchased.

Power cord sets for use in other countries or regions must meet the requirements of the country and region where the computer is used.

Requirements for all countries

The following requirements are applicable to all countries and regions:

- The length of the power cord set must be at least **1.0 m** (3.3 ft) and no more than **2.0 m** (6.5 ft).
- All power cord sets must be approved by an acceptable accredited agency responsible for evaluation in the country or region where the power cord set will be used.
- The power cord sets must have a minimum current capacity of 10 A and a nominal voltage rating of 125 or 250 V ac, as required by the power system of each country or region.
- The appliance coupler must meet the mechanical configuration of an EN 60 320/IEC 320 Standard Sheet C13 connector for mating with the appliance inlet on the back of the computer.

Requirements for specific countries and regions

Table 10-1 Power cord requirements for specific countries and regions

Country/region	Accredited agency	Applicable note number
Argentina	IRAM	1
Australia	SAA	1
Austria	OVE	1
Belgium	CEBEC	1
Brazil	ABNT	1
Canada	CSA	2
Chile	IMQ	1
Denmark	DEMKO	1
Finland	FIMKO	1
France	UTE	1
Germany	VDE	1
India	BIS	1
Israel	SII	1
Italy	IMQ	1
Japan	JIS	3
The Netherlands	KEMA	1
New Zealand	SANZ	1
Norway	NEMKO	1
The People's Republic of China	CCC	4
Saudi Arabia	SASO	7
Singapore	PSB	1
South Africa	SABS	1
South Korea	KTL	5
Sweden	SEMKO	1
Switzerland	SEV	1
Taiwan	BSMI	6
Thailand	TISI	1
The United Kingdom	ASTA	1
The United States	UL	2

1. The flexible cord must be Type H05VV-F, 3-conductor, 0.75 mm² conductor size. Power cord set fittings (appliance coupler and wall plug) must bear the certification mark of the agency responsible for evaluation in the country or region where it will be used.

Table 10-1 Power cord requirements for specific countries and regions (continued)

Country/region	Accredited agency	Applicable note number
		2. The flexible cord must be Type SVT/SJT or equivalent, No. 18 AWG, 3-conductor. The wall plug must be a two-pole grounding type with a NEMA 5-15P (15 A, 125 V ac) or NEMA 6-15P (15 A, 250 V ac) configuration. CSA or C-UL mark. UL file number must be on each element.
		3. The appliance coupler, flexible cord, and wall plug must bear a “T” mark and registration number in accordance with the Japanese Dentori Law. The flexible cord must be Type VCTF, 3-conductor, 0.75 mm ² or 1.25 mm ² conductor size. The wall plug must be a two-pole grounding type with a Japanese Industrial Standard C8303 (7 A, 125 V ac) configuration.
		4. The flexible cord must be Type RVV, 3-conductor, 0.75 mm ² conductor size. Power cord set fittings (appliance coupler and wall plug) must bear the CCC certification mark.
		5. The flexible cord must be Type H05VV-F 3-conductor, 0.75 mm ² conductor size. KTL logo and individual approval number must be on each element. Corset approval number and logo must be printed on a flag label.
		6. The flexible cord must be Type HVCTF 3-conductor, 1.25 mm ² conductor size. Power cord set fittings (appliance coupler, cable, and wall plug) must bear the BSMI certification mark.
		7. For 127 V ac, the flexible cord must be Type SVT or SJT 3-conductor, 18 AWG, with plug NEMA 5-15P (15 A, 125 V ac), with UL and CSA or C-UL marks. For 240 V ac, the flexible cord must be Type H05VV-F 3-conductor, 0.75 mm ² or 1.00 mm ² conductor size, with plug BS 1363/A with BSI or ASTA marks.

11 Statement of memory volatility

The purpose of this chapter is to provide general information regarding nonvolatile memory in HP Business computers. This chapter also provides general instructions for restoring nonvolatile memory that can contain personal data after the system has been powered off and the hard drive has been removed.



HP Business computer products that use Intel®-based or AMD®-based system boards contain volatile DDR memory. The amount of nonvolatile memory present in the system depends upon the system configuration. Intel-based and AMD-based system boards contain nonvolatile memory subcomponents as originally shipped from HP, assuming that no subsequent modifications have been made to the system and assuming that no applications, features, or functionality have been added to or installed on the system.

Following system shutdown and removal of all power sources from an HP Business computer system, personal data can remain on volatile system memory (DIMMs) for a finite period of time and will also remain in nonvolatile memory. Use the steps below to remove personal data from the computer, including the nonvolatile memory found in Intel-based and AMD-based system boards.



NOTE: If your tablet has a keyboard base, connect to the keyboard base before beginning steps in this chapter.

Current BIOS steps

1. Follow steps (a) through (l) below to restore the nonvolatile memory that can contain personal data. Restoring or reprogramming nonvolatile memory that does not store personal data is neither necessary nor recommended.
 - a. Turn on or restart the computer, and then press **esc** while the “Press the ESC key for Startup Menu” message is displayed at the bottom of the screen.
 **NOTE:** If the system has a BIOS administrator password, enter the password at the prompt.
 - b. Select **Main**, select **Apply Factory Defaults and Exit**, and then select **Yes** to load defaults.
The computer will reboot.
 - c. During the reboot, press **esc** while the “Press the ESC key for Startup Menu” message is displayed at the bottom of the screen.
 **NOTE:** If the system has a BIOS administrator password, enter the password at the prompt.
 - d. Select the **Security** menu, select **Restore Security Settings to Factory Defaults**, and then select **Yes** to restore security level defaults.
The computer will reboot.
 - e. During the reboot, press **esc** while the “Press the ESC key for Startup Menu” message is displayed at the bottom of the screen.
 **NOTE:** If the system has a BIOS administrator password, enter the password at the prompt.
 - f. If an asset or ownership tag is set, select the **Security** menu and scroll down to the **Utilities** menu. Select **System IDs**, and then select **Asset Tracking Number**. Clear the tag, and then make the selection to return to the prior menu.

- g.** If a DriveLock password is set, select the **Security** menu, and scroll down to **Hard Drive Utilities** under the **Utilities** menu. Select **Hard Drive Utilities**, select **DriveLock**, then uncheck the checkbox for **DriveLock password on restart**. Select **OK** to proceed.
- h.** Select the **Main** menu, and then select **Reset BIOS Security to factory default**. Click **Yes** at the warning message.
The computer will reboot.
- i.** During the reboot, press **esc** while the “Press the ESC key for Startup Menu” message is displayed at the bottom of the screen.



NOTE: If the system has a BIOS administrator password, enter the password at the prompt.

- j.** Select the **Main** menu, select **Apply Factory Defaults and Exit**, select **Yes** to save changes and exit, and then select **Shutdown**.
 - k.** Reboot the system. If the system has a Trusted Platform Module (TPM) and/or fingerprint reader, one or two prompts will appear—one to clear the TPM and the other to Reset Fingerprint Sensor; press or tap **F1** to accept or **F2** to reject.
 - l.** Remove all power and system batteries for at least 24 hours.
- 2.** Complete one of the following:
- Remove and retain the storage drive.
 - or –
 - Clear the drive contents by using a third-party utility designed to erase data from an SSD.
 - or –
 - Clear the contents of the drive by using the following BIOS Setup Secure Erase command option steps:



IMPORTANT: If you clear data using Secure Erase, it cannot be recovered.

- a.** Turn on or restart the computer, and then press **esc** while the “Press the ESC key for Startup Menu” message is displayed at the bottom of the screen.
 - b.** Select the **Security** menu and scroll down to the **Utilities** menu.
 - c.** Select **Hard Drive Utilities**.
 - d.** Under **Utilities**, select **Secure Erase**, select the hard drive storing the data you want to clear, and then follow the on-screen instructions to continue.
- or –
- Clear the contents of the drive using the following Disk Sanitizer commands steps:



IMPORTANT: If you clear data using Disk Sanitizer, it cannot be recovered.



NOTE: The amount of time it takes for Disk Sanitizer to run can take several hours. Plug the computer into an AC outlet before starting.

- a.** Turn on or restart the computer, and then press **esc** while the “Press the ESC key for Startup Menu” message is displayed at the bottom of the screen.
- b.** Select the **Security** menu and scroll down to the **Utilities** menu.

- c. Select **Hard Drive Utilities**.
- d. Under **Utilities**, select **Disk Sanitizer**, select the hard drive storing the data you want to clear, and then follow the on-screen instructions to continue.

Nonvolatile memory usage

Table 11-1 Troubleshooting steps for nonvolatile memory usage

Nonvolatile memory type	Amount (Size)	Does this memory store customer data?	Does this memory retain data when power is removed?	What is the purpose of this memory?	How is data input into this memory?	How is this memory write-protected?
HP Sure Start flash (select models only)	8 MB	No	Yes	Provides protected backup of critical System BIOS code, EC firmware, and critical computer configuration data for select platforms that support HP Sure Start. For more information, see Using HP Sure Start (select models only) on page 89.	Data cannot be written to this device via the host processor. The content is managed solely by the HP Sure Start Embedded Controller.	This memory is protected by the HP Sure Start Embedded Controller.
Real Time Clock (RTC) battery backed-up CMOS configuration memory	256 bytes	No	Yes	Stores system date and time and noncritical data.	RTC battery backed-up CMOS is programmed using Computer Setup (BIOS), or by changing the Microsoft® Windows date & time.	This memory is not write-protected.
Controller (NIC) EEPROM	64 KB (not customer accessible)	No	Yes	Stores NIC configuration and NIC firmware.	NIC EEPROM is programmed using a utility from the NIC vendor that can be run from DOS.	A utility must be used to write data to this memory and is available from the NIC vendor. Writing data to this ROM in an inappropriate manner will render the NIC nonfunctional.
DIMM Serial Presence Detect (SPD) configuration data	256 bytes per memory module, 128 bytes programmable (not customer accessible)	No	Yes	Stores memory module information.	DIMM SPD is programmed by the memory vendor.	Data cannot be written to this memory when the module is installed in a computer. The specific write-protection method varies by memory vendor.

Table 11-1 Troubleshooting steps for nonvolatile memory usage (continued)

Nonvolatile memory type	Amount (Size)	Does this memory store customer data?	Does this memory retain data when power is removed?	What is the purpose of this memory?	How is data input into this memory?	How is this memory write-protected?
System BIOS	9 MB	Yes	Yes	Stores system BIOS code and computer configuration data.	System BIOS code is programmed at the factory. Code is updated when the system BIOS is updated. Configuration data and settings are input using the Computer Setup (BIOS) or a custom utility.	NOTE: Writing data to this ROM in an inappropriate manner can render the computer nonfunctional. A utility must be used for writing data to this memory and is available on the HP website; go to http://www.hp.com/support . Select Find your product , and then follow the on-screen instructions.
Intel Management Engine Firmware (present only in select Elite or Z models. For more information, go to http://www.hp.com/support . Select Find your product , and then follow the on-screen instructions.)	1.5 MB or 7 MB	Yes	Yes	Stores Management Engine Code, Settings, Provisioning Data and iAMT third-party data store.	Management Engine Code is programmed at the factory. Code is updated via Intel secure firmware update utility. Unique Provisioning Data can be entered at the factory or by an administrator using the Management Engine (MEBx) setup utility. The third-party data store contents can be populated by a remote management console or local applications that have been registered by an administrator to have access to the space.	The Intel chipset is configured to enforce hardware protection to block all direct read/write access to this area. An Intel utility must be used for updating the firmware. Only firmware updates digitally signed by Intel can be applied using this utility.
Bluetooth flash (select products only)	2 Mb	No	Yes	Stores Bluetooth configuration and firmware.	Bluetooth flash is programmed at the factory. Tools for writing data to this memory are not publicly available but can be obtained from the silicon vendor.	A utility must be used for writing data to this memory and is made available through newer versions of the driver whenever the flash requires an upgrade.
802.11 WLAN EEPROM	4 Kb to 8 Kb	No	Yes	Stores configuration and calibration data.	802.11 WLAN EEPROM is programmed at the factory. Tools for writing data to this memory are not made public.	A utility must be used for writing data to this memory and is typically not made available to the public unless a firmware upgrade is necessary to address a unique issue.
Webcam (select products only)	64 Kb	No	Yes	Stores webcam configuration and firmware.	Webcam memory is programmed using a utility from the device manufacturer that can be run from Windows.	A utility must be used for writing data to this memory and is typically not made available to the public unless a firmware

Table 11-1 Troubleshooting steps for nonvolatile memory usage (continued)

Nonvolatile memory type	Amount (Size)	Does this memory store customer data?	Does this memory retain data when power is removed?	What is the purpose of this memory?	How is data input into this memory?	How is this memory write-protected?
Fingerprint reader (select products only)	512 KB flash	Yes	Yes	Stores fingerprint templates.	Fingerprint reader memory is programmed by user enrollment in HP ProtectTools Security Manager.	upgrade is necessary to address a unique issue. Only a digitally signed application can make the call to write to the flash.

Questions and answers

1. How can the BIOS settings be restored (returned to factory settings)?



IMPORTANT: Restore defaults does not securely erase any data on your hard drive. See question and answer 6 for steps to securely erase data.

Restore defaults does not reset the Custom Secure Boot keys. See question and answer 7 for information about resetting the keys.

- a. Turn on or restart the computer, and then press **esc** while the “Press the ESC key for Startup Menu” message is displayed at the bottom of the screen.
- b. Select **Main**, and then select **Apply Factory Defaults and Exit**.
- c. Follow the on-screen instructions.
- d. Select **Main**, select **Save Changes and Exit**, and then follow the on-screen instructions.

2. What is a UEFI BIOS, and how is it different from a legacy BIOS?

The Unified Extensible Firmware Interface (UEFI) BIOS is an industry-standard software interface between the platform firmware and an operating system (OS). It is a replacement for the older BIOS architecture, but supports much of the legacy BIOS functionality.

Like the legacy BIOS, the UEFI BIOS provides an interface to display the system information and configuration settings and to change the configuration of your computer before an OS is loaded. BIOS provides a secure run-time environment that supports a Graphic User Interface (GUI). In this environment, you can use either a pointing device (touch screen, touchpad, pointing stick, or USB mouse) or the keyboard to navigate and make menu and configuration selections. The UEFI BIOS also contains basic system diagnostics.

The UEFI BIOS provides functionality beyond that of the legacy BIOS. In addition, the UEFI BIOS works to initialize the computer’s hardware before loading and executing the OS; the run-time environment allows the loading and execution of software programs from storage devices to provide more functionality, such as advanced hardware diagnostics (with the ability to display more detailed system information) and advanced firmware management and recovery software.

HP has provided options in Computer Setup (BIOS) to allow you to run in legacy BIOS, if required by the operating system. Examples of this requirement would be if you upgrade or downgrade the OS.

3. Where does the UEFI BIOS reside?

The UEFI BIOS resides on a flash memory chip. A utility must be used to write to the chip.

4. What kind of configuration data is stored on the DIMM Serial Presence Detect (SPD) memory module? How would this data be written?

The DIMM SPD memory contains information about the memory module, such as size, serial number, data width, speed/timing, voltage, and thermal information. This information is written by the module manufacturer and stored on an EEPROM. This EEPROM cannot be written to when the memory module is installed in a computer. Third-party tools do exist that can write to the EEPROM when the memory module is not installed in a computer. Various third-party tools are available to read SPD memory.

5. What is meant by “Restore the nonvolatile memory found in Intel-based system boards”?

This message relates to clearing the Real Time Clock (RTC) CMOS memory that contains computer configuration data.

6. How can the BIOS security be reset to factory defaults and data erased?

 **IMPORTANT:** Resetting will result in the loss of information.

These steps will not reset Custom Secure Boot Keys. See question and answer 7 for information about resetting the keys.

- a. Turn on or restart the computer, and then press **esc** while the “Press the ESC key for Startup Menu” message is displayed at the bottom of the screen.
- b. Select **Main**, and then select **Reset Security to Factory Defaults**.
- c. Follow the on-screen instructions.
- d. Select **Main**, select **Save Changes and Exit**, and then follow the on-screen instructions.

7. How can the Custom Secure Boot Keys be reset?

Secure Boot is a feature to ensure that only authenticated code can start on a platform. If you enabled Secure Boot and created Custom Secure Boot Keys, simply disabling Secure Boot will not clear the keys. You must also select to clear the Custom Secure Boot Keys. Use the same Secure Boot access procedure you used to create the Custom Secure Boot Keys, but make the selection to clear or delete all Secure Boot Keys.

- a. Turn on or restart the computer, and then press **esc** while the “Press the ESC key for Startup Menu” message is displayed at the bottom of the screen.
- b. Select the **Security** menu, select **Secure Boot Configuration**, and then follow the on-screen instructions.
- c. At the **Secure Boot Configuration** window, select **Secure Boot**, select **Clear Secure Boot Keys**, and then follow the on-screen instructions to continue.

Using HP Sure Start (select models only)

Select computer models are configured with HP Sure Start, a technology that continuously monitors your computer's BIOS for attacks or corruption. If the BIOS becomes corrupted or is attacked, HP Sure Start restores the BIOS to its previously safe state, without user intervention. Those select computer models ship with HP Sure Start configured and enabled. HP Sure Start is configured and already enabled so that most users can use the HP Sure Start default configuration. The default configuration can be customized by advanced users.

To access the latest documentation on HP Sure Start, go to <http://www.hp.com/support>. Select **Find your product**, and then follow the on-screen instructions.

12 Recycling

When a nonrechargeable or rechargeable battery has reached the end of its useful life, do not dispose of the battery in general household waste. Follow the local laws and regulations in your area for battery disposal.

HP encourages customers to recycle used electronic hardware, HP original print cartridges, and rechargeable batteries. For more information about recycling programs, see the HP Web site at <http://www.hp.com/recycle>.

Index

A

- AC adapter 19
- AC adapter and battery light, identifying 5
- action keys
 - identifying 12
- antennas
 - illustrated 19
 - removing 57
- audio-out (headphone)/audio-in (microphone) combo jack, identifying 5

B

- backup, creating 63
- backups 63
- battery
 - illustrated 16, 31
 - removing 31
- BIOS
 - determining version 60
 - downloading an update 60
 - updating 60
- Bluetooth label 13
- boot order
 - changing using the f9 prompt 61
- boot order, changing 64
- bottom components 12
- bottom cover
 - illustrated 17
 - removing 29
- buttons
 - left touchpad 9
 - power 10
 - right touchpad 9

C

- cache memory
 - product description 2
- camera
 - identifying 8
 - product description 2
- camera light, identifying 8
- caps lock light, identifying 10

- cautions
 - electrostatic discharge 22
- chipset, product description 1
- components
 - bottom 12
 - display 7
 - keyboard area 8
 - left side 6
 - right side 5
- computer major components, illustrated 15
- Computer Setup
 - navigating and selecting 59
 - restoring factory settings 59
 - starting 59
- computer setup 59
- computer specifications 73
- connectors
 - power 6

D

- display assembly
 - illustrated 16
 - removing 51
 - spare part numbers 16
- display assembly subcomponents
 - illustrated 18
 - removing 51
- display bezel
 - illustrated 19
 - removing 52
- display cable
 - illustrated 19
 - removing 56
- display components 7
- display enclosure
 - illustrated 19
 - removing 57
- display panel
 - illustrated 19
 - product description 1
 - removing 54
- display panel stretchable adhesive tape 19
- display specifications 74

- drive light, identifying 6

E

- electrostatic discharge (ESD) 22
 - preventing damage 23
- esc key, identifying 11

F

- fan
 - illustrated 17
 - removing 44
 - spare part number 44
- fan/heat sink assembly
 - removing 48
- feet
 - removal 27
 - spare part numbers 27
- fingerprint reader, identifying 11
- fingerprint sensor
 - illustrated 16
 - removing 39
- fn key, identifying 11

G

- grounding methods 24
- guidelines
 - packaging 25
 - transporting 25
 - workstation 22

H

- hard drive
 - illustrated 16
 - product description 2
 - removing 32
 - specifications 75
- hard drive bracket
 - illustrated 16, 32
- hard drive cable
 - illustrated 16, 32
- hard drive connector
 - removing 33
- hard drive cover
 - removing 32

- HDMI port
 - identifying 5
 - heat sink assembly
 - illustrated 17
 - spare part number 48
 - hinge cover
 - illustrated 16
 - hinges
 - illustrated 19
 - removing 54, 55
 - HP PC Hardware Diagnostics UEFI
 - downloading 69
 - starting 69
 - using 68
 - HP PC Hardware Diagnostics Windows
 - downloading 67
 - installing 68
 - using 67
 - HP Recovery media
 - recovery 64
 - HP Sure Recover 65
 - HP Sure Start 89
- I**
- internal microphones, identifying 7
- J**
- jacks
 - audio-out (headphone)/audio-in (microphone) 5
 - network 5
 - RJ-45 (network) 5
- K**
- keyboard
 - illustrated 16
 - product description 3
 - keys
 - action 12
 - esc 11
 - fn 11
 - Windows 11
- L**
- labels
 - Bluetooth 13
 - regulatory 13
 - serial number 13
 - service 13
 - wireless certification 13
 - WLAN 13
- left side components 6
 - lights
 - AC adapter and battery 5
 - camera 8
 - caps lock 10
 - drive 6
 - mute 10
 - power 6
 - RJ-45 (network) status 5
- M**
- M.2 solid-state drive
 - specifications 76
 - memory
 - illustrated 17
 - nonvolatile 83
 - product description 1
 - volatile 83
 - memory module
 - removing 36
 - microphone
 - illustrated 19
 - spare part number 19
 - model name 1
 - mute light, identifying 10
- N**
- network jack, identifying 5
 - nonvolatile memory 83
- O**
- operating system, product description 3
 - Optane memory module
 - spare part number 37
 - speare part number 16
- P**
- packaging guidelines 25
 - pointing device, product description 3
 - ports
 - HDMI 5
 - product description 3
 - USB SuperSpeed 5, 6
 - USB SuperSpeed port with HP Sleep and Charge 5
 - USB Type-C 6
 - power button, identifying 10
 - power connector
 - identifying 6
 - illustrated 16
 - power connector cable
 - removing 40
 - power cord
 - requirements for all countries 79
 - requirements for specific countries and regions 80
 - set requirements 79
 - power lights, identifying 6
 - power requirements, product description 3
 - processor 1
 - product description
 - cache memory 2
 - camera 2
 - chipset 1
 - display panel 1
 - hard drive 2
 - keyboard 3
 - media card reader 3
 - memory 1
 - operating system 3
 - pointing device 3
 - ports 3
 - power requirements 3
 - processor 1
 - product name 1
 - RJ-45 (network) jack 2
 - security 3
 - serviceability 4
 - wireless networking 2
 - product name 1
 - product name and number, computer 13
- R**
- recovery 63
 - discs 64
 - HP Recovery partition 64
 - media 64
 - USB flash drive 64
 - recovery media
 - creating using HP Cloud Recovery Download Tool 63
 - creating using Windows tools 63

- regulatory information
 - regulatory label 13
 - wireless certification labels 13
- Remote HP PC Hardware Diagnostics
 - UEFI settings
 - customizing 70
 - using 70
- removal/replacement
 - procedures 27
- removing personal data from volatile
 - system memory 83
- restoring 63
- right side components 5
- RJ-45 (network) jack
 - product description 2
- RJ-45 (network) jack, identifying 5
- RJ-45 (network) status lights,
 - identifying 5

S

- Screw Kit 20
- security cable slot, identifying 6
- security, product description 3
- serial number, computer 13
- service labels, locating 13
- serviceability, product description 4
- setup utility
 - navigating and selecting 59
 - restoring factory settings 59
- slots
 - memory card reader 6
 - security cable 6
- solid-state drive
 - illustrated 16
 - removal 37
 - spare part numbers 37
 - specifications 77
- speakers
 - identifying 11
 - illustrated 16
 - removing 38
- special keys, using 11
- specifications
 - computer 73
 - display 74
 - hard drive 75
 - M.2 solid-state drive 76
 - solid-state drive 77
- static electricity 23

- Sure Start
 - using 62
- system board
 - removing 45
 - spare part number 17, 45
- system board hook 17
 - removing 31
- system memory, removing personal
 - data from volatile 83
- system restore point, creating 63

T

- top cover
 - illustrated 16
- top cover/keyboard 58
- touchpad
 - removing 41, 42
 - settings 8
 - spare part number 41, 42
- touchpad buttons
 - identifying 9
- touchpad click board
 - illustrated 16
 - removing 41, 42
 - spare part number 41, 42
- touchpad click board cable
 - illustrated 16
 - spare part number 41
- touchpad zone, identifying 9
- TPM settings 61
- transporting guidelines 25
- traveling with the computer 13

U

- USB board
 - illustrated 16
 - removing 43
- USB board cable
 - illustrated 16
- USB SuperSpeed port with HP Sleep
 - and Charge, identifying 5
- USB SuperSpeed port, identifying 5, 6
- USB Type-C port, identifying 6

V

- vents, identifying 11, 12

W

- webcam
 - illustrated 19

- webcam cable
 - removing 56
- webcam/microphone cable
 - removing 54
- webcam/microphone module
 - removing 53
- Windows
 - backup 63
 - recovery media 63
 - system restore point 63
- Windows key, identifying 11
- Windows tools, using 63
- wireless antennas
 - illustrated 19
 - removing 57
- wireless certification label 13
- wireless networking
 - product description 2
- WLAN
 - illustrated 17
- WLAN antennas, identifying 7
- WLAN device 13
- WLAN label 13
- WLAN module
 - removing 34
- workstation guidelines 22

