



Maintenance and Service Guide

SUMMARY

This guide provides information about spare parts, removal and replacement of parts, security, backing up, and more.

© Copyright 2020 HP Development Company, L.P.

Bluetooth is a trademark owned by its proprietor and used by HP Inc. under license. Intel, Optane, and Thunderbolt are trademarks of Intel Corporation or its subsidiaries in the U.S. and/or other countries. NVIDIA, GeForce, G-SYNC, and Optimus are trademarks and/or registered trademarks of NVIDIA Corporation in the U.S. and other countries. SDHC, SDXC, and microSD are trademarks or registered trademarks of SD-3C LLC. Microsoft and Windows are either registered trademarks or trademarks of Microsoft Corporation in the United States and/or other countries. USB Type-C® is a registered trademark of USB Implementers Forum. DisplayPort™ and the DisplayPort™ logo are trademarks owned by the Video Electronics Standards Association (VESA®) in the United States and other countries. Miracast is a registered trademark of Wi-Fi Alliance.

The information contained herein is subject to change without notice. The only warranties for HP products and services are set forth in the express warranty statements accompanying such products and services. Nothing herein should be construed as constituting an additional warranty. HP shall not be liable for technical or editorial errors or omissions contained herein.

Second Edition: May 2020

First Edition: May 2020

Document Part Number: M08080-002

Product notice

This guide describes features that are common to most models. Some features may not be available on your computer.

Not all features are available in all editions or versions of Windows. Systems may require upgraded and/or separately purchased hardware, drivers, software or BIOS update to take full advantage of Windows functionality. Windows 10 is automatically updated, which is always enabled. ISP fees may apply and additional requirements may apply over time for updates. Go to <http://www.microsoft.com> for details.

To access the latest user guides, go to <http://www.hp.com/support>, and follow the instructions to find your product. Then select **User Guides**.

Software terms

By installing, copying, downloading, or otherwise using any software product preinstalled on this computer, you agree to be bound by the terms of the HP End User License Agreement (EULA). If you do not accept these license terms, your sole remedy is to return the entire unused product (hardware and software) within 14 days for a full refund subject to the refund policy of your seller.

For any further information or to request a full refund of the price of the computer, please contact your seller.

Important Notice about Customer Self-Repair Parts

Your computer includes Customer Self-Repair parts and parts that should be accessed by only an authorized service provider.



IMPORTANT: See "Removal and replacement procedures for Customer Self-Repair parts" for details.

Accessing parts described in "Removal and replacement procedures for authorized service provider parts" can damage the computer or void your warranty.

Safety warning notice

Reduce the possibility of heat-related injuries or of overheating the computer by following the practices described.

 **WARNING!** To reduce the possibility of heat-related injuries or of overheating the computer, do not place the computer directly on your lap or obstruct the computer air vents. Use the computer only on a hard, flat surface. Do not allow another hard surface, such as an adjoining optional printer, or a soft surface, such as pillows or rugs or clothing, to block airflow. Also, do not allow the AC adapter to come into contact with the skin or a soft surface, such as pillows or rugs or clothing, during operation. The computer and the AC adapter comply with the user-accessible surface temperature limits defined by applicable safety standards.

Table of contents

1 Product description	1
2 Components	5
Right side	5
Left side	6
Rear	7
Display	7
Low blue light mode (select products only)	7
Keyboard area	8
Touchpad components	9
Lights	9
Button	10
Special keys	11
Bottom	13
Labels	14
HP OMEN Command Center	14
3 Illustrated parts catalog	17
Computer major components	17
Display assembly subcomponents	20
Cables	21
Miscellaneous parts	22
4 Removal and replacement procedures preliminary requirements	25
Tools required	25
Service considerations	25
Plastic parts	25
Cables and connectors	25
Drive handling	25
Workstation guidelines	26
Electrostatic discharge information	26
Generating static electricity	27
Preventing electrostatic damage to equipment	27
Personal grounding methods and equipment	28
Grounding the work area	28
Recommended materials and equipment	28

Packaging and transporting guidelines	29
5 Removal and replacement procedures for Customer Self-Repair parts	31
Component replacement procedures	31
Preparation for disassembly	31
Bottom cover	31
Solid-state drive	32
Memory modules	34
6 Removal and replacement procedures for authorized service provider parts	37
Component replacement procedures	37
Battery	37
RGB keyboard control board (select products only)	38
Power connector cable	39
Speakers	40
Card reader/audio board	41
Heat sink	42
Fans	45
USB board	46
RJ-45 door	47
System board	48
Infrared (IR) board	50
Touchpad	51
Display assembly	53
Keyboard with top cover	62
7 Using Setup Utility (BIOS)	65
Starting Setup Utility (BIOS)	65
Updating Setup Utility (BIOS)	65
Determining the BIOS version	65
Preparing for a BIOS update	66
Downloading a BIOS update	66
Installing a BIOS update	66
8 Backing up, restoring, and recovering	69
Backing up information and creating recovery media	69
Using Windows tools	69
Using the HP Cloud Recovery Download Tool to create recovery media (select products only)	69
Restoring and recovery	70
Restoring, resetting, and refreshing using Windows tools	70

Recovering using HP Recovery media	70
Changing the computer boot order	70
Using HP Sure Recover (select products only)	71
9 Using HP PC Hardware Diagnostics	73
Using HP PC Hardware Diagnostics Windows (select products only)	73
Using an HP PC Hardware Diagnostics Windows hardware failure ID code	73
Accessing HP PC Hardware Diagnostics Windows	73
Accessing HP PC Hardware Diagnostics Windows from HP Help and Support	73
Accessing HP PC Hardware Diagnostics Windows from Support Assistant	74
Downloading HP PC Hardware Diagnostics Windows	74
Downloading the latest HP PC Hardware Diagnostics Windows version from HP	74
Downloading the HP PC Hardware Diagnostics Windows from the Microsoft Store	74
Downloading HP Hardware Diagnostics Windows by product name or number (select products only)	74
Installing HP PC Hardware Diagnostics Windows	75
Using HP PC Hardware Diagnostics UEFI	75
Using an HP PC Hardware Diagnostics UEFI hardware failure ID code	75
Starting HP PC Hardware Diagnostics UEFI	75
Downloading HP PC Hardware Diagnostics UEFI to a USB flash drive	76
Downloading the latest HP PC Hardware Diagnostics UEFI version	76
Downloading HP PC Hardware Diagnostics UEFI by product name or number (select products only)	76
Using Remote HP PC Hardware Diagnostics UEFI settings (select products only)	76
Downloading Remote HP PC Hardware Diagnostics UEFI	77
Downloading the latest Remote HP PC Hardware Diagnostics UEFI version	77
Downloading Remote HP PC Hardware Diagnostics UEFI by product name or number	77
Customizing Remote HP PC Hardware Diagnostics UEFI settings	77
10 Specifications	79
Computer specifications	79
39.6 cm (15.6 in) display specifications	79
Solid-state drive specifications	80
11 Power cord set requirements	83
Requirements for all countries	83
Requirements for specific countries and regions	83
12 Recycling	85

1 Product description

This table provides detailed product information.

Table 1-1 Product components and their descriptions

Category	Description
Product Name	OMEN Laptop Model number: 15-ek0000~15-ek0999 CTO model number: 15t-ek000
Processors	10th Generation Intel® Core™ processors Intel Core i7-10750H (2.6 GHz [turbo up to 5.0 GHz], 6 cores, 12 MB Intel Smart Cache, 45 W, Intel UHD Graphics) Intel Core i5-10300H (2.5 GHz [turbo up to 4.5 GHz] 4 cores, 8 MB Intel Smart Cache, 45 W, Intel UHD Graphics)
Graphics	Internal graphics Intel UHD Graphics Discrete graphics NVIDIA® GeForce® RTX 2070 with up to 8 GB of dedicated GDDR6 video memory NVIDIA GeForce RTX 2070 Super with up to 8 GB of dedicated GDDR6 video memory (G-SYNC™ supportable) NVIDIA GeForce RTX 2060 with up to 6 GB of dedicated GDDR6 video memory NVIDIA GeForce GTX 1660Ti with up to 6 GB of dedicated GDDR6 video memory NVIDIA GeForce GTX 1650Ti with up to 4 GB of dedicated GDDR6 video memory NVIDIA GeForce GTX 1650 with up to 4 GB of dedicated GDDR6 video memory Supports HD Decode, DX12, and HDMI Supports Optimus™ Support GPS (GPU Performance Scaling) Supports VR
Display	39.6 cm (15.6 in), narrow bezel, UWVA Full high definition (FHD) (1920 × 1080), antiglare, WLED, flat (3.2 mm), 45% NTSC, eDP 1.2, 250 nits FHD, antiglare, WLED, flat (3.2 mm), 45% NTSC, eDP 1.3 + PSR, 250 nits, 144 Hz FHD, antiglare, WLED, ultraslim (2.6 mm), 72% NTSC, eDP 1.2, 300 nits FHD, antiglare, WLED, ultraslim (2.6 mm), 72% NTSC, eDP 1.4 + PSR, 300 nits, 144 Hz FHD, antiglare, WLED, ultraslim (2.6 mm), 100% sRGB, eDP 1.4 + PSR2, 300 nits, 300 Hz Ultra high definition (UHD) (3840 × 2160), antiglare, LED, ultraslim (2.6 mm), 100% sRGB, eDP 1.4 + PSR2, 400 nits, 120 Hz UHD, BrightView, AMOLED, ultraslim, 100% DCI-P3, eDP + PSR, 400 nits, 120 Hz

Table 1-1 Product components and their descriptions (continued)

Category	Description
Memory	Two customer-accessible memory module slots supporting up to 32 GB of RAM
	DDR4-2933 Dual-channel support (DDR4-3200 downgrade to DDR4-2933)
	Supports the following configurations:
	<ul style="list-style-type: none"> • 32 GB (16 × 2) • 16 GB (8 × 2) • 12 GB (8 + 4) • 8 GB (8 × 1) or (4 × 2)
Storage	PCIe, NVMe, M.2 2280 solid-state drives
	<ul style="list-style-type: none"> • 1 TB, PCIe, TLC, SS • 512 GB, PCIe, TLC • 256 GB, PCIe, TLC
	Multiple storage configurations (supports RAID 0 for dual SSD configuration)
	[512GB PCIe NVMe TLC SSD + 512GB PCIe NVMe TLC SSD] RAID 0
	[256GB PCIe NVMe TLC SSD + 256GB PCIe NVMe TLC SSD] RAID 0
	Intel Optane® H (3D Xpoint) Solution, PCIe, Gen3 × 2 × 2, M.2, SSD
	32 GB Optane memory + 512 GB solid-state drive
Audio and video	Audio brand: BANG & OLUFSEN
	Audio control panel: OMEN Audio Control
	Support for HP Audio Boost 2.0 (with discrete amplifier)
	Support for DTS X: Ultra
	Dual speakers
	HP Wide Vision HD Camera: indicator LED, USB 2.0, HD BSI sensor, f2.0, WDR, 88° WFOV
	720p by 30 frames per second
Dual-array digital microphone with appropriate software: beam forming, echo cancellation, noise suppression	
RJ-45 (network) jack	Integrated 10/100/1000 NIC
Wireless	Wireless Local Area Network (WLAN)
	Intel Wi-Fi 6 AX201 + Bluetooth® 5 (non-vPro) (802.11ax 2 × 2, MU-MIMO, supporting gigabit file transfer speeds)
	Compatible with Miracast® devices
Media card reader	Supports microSD™, SDHC™, SDXC™
	Push-push insertion/removal
Ports	Hot plug/unplug and autodetect for correct output to wide-aspect vs. standard aspect video
	HDMI v2.0a supporting: up to 4096 × 2160 @ 60 Hz with HDCP 2.2

Table 1-1 Product components and their descriptions (continued)

Category	Description
	Audio-out (headphone)/audio-in (microphone) combo jack
	USB 3.2 Gen 2 Type C with Thunderbolt™ Gen 3 technology (right side) (select products only)
	USB 3.2 Gen 1 Type C (supports HP Sleep & Charge; right side)
	USB 3.2 Gen 1 Type A (supports HP Sleep & Charge; left side)
	RJ-45 (network) jack
	Mini DisplayPort 1.4
	AC Smart Pin adapter plug
Keyboard/pointing devices	Keyboard
	Full size, backlit, 3-coat paint, island style, 1-zone lighting (with or without numeric keypad)
	Full size, backlit, 3-coat paint, island style, 4-zone lighting (with or without numeric keypad)
	Full size, backlit, 3-coat paint, island style, RGB per key lighting
	Special highlighting for WASD keys
	Supports 26-key RO anti-ghosting keys
	Touchpad
	ClickPad with image sensor
	Multitouch gestures enabled
	Precision touchpad support
	Support for Modern Trackpad Gestures
	Taps enabled as default
Power requirements	Battery
	6 cell, 70.9 Whr, polymer, HP Long Life
	3 cell, 52.5 Whr, polymer, HP Long Life
	HP Fast Charge Technology
	Smart AC adapters
	200 W, slim barrel, PFC, 4.5 mm
	150 W, slim barrel, PFC, 4.5 mm
	Power cord
	C5, 1 m
	C13, 1 m (for use with 200 W AC adapter)
Security	Supports Trusted Platform Module (TPM) 2.0, firmware based
Operating system	Windows® 10 Home 64
	Windows 10 Home 64 Advanced
	Windows 10 Home 64 Advanced Single Language

Table 1-1 Product components and their descriptions (continued)

Category	Description
	Windows 10 Home 64 High-End Chinese Market PPP
	Windows 10 Home 64 Plus Single Language Africa Market
	Windows 10 Home 64 Plus Single Language APAC EM PPP
	Windows 10 Home 64 Plus Single Language India Market
	Windows 10 Home 64 Plus Single Language Indonesia Market
	Windows 10 Pro 64
	FreeDOS 3.0
Serviceability	End user replaceable parts
	Solid-state drive
	Memory modules

2 Components

Your computer features top-rated components. This chapter provides details about your components, where they are located, and how they work.

Right side

Use the illustration and table to identify the components on the right side of the computer.

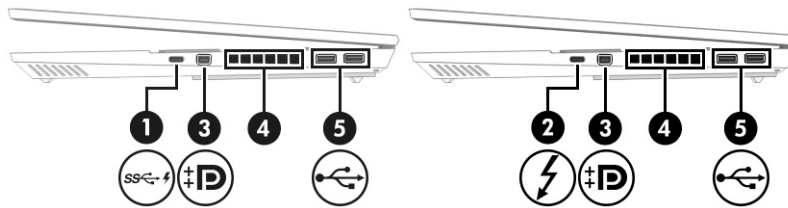





Table 2-1 Right-side components and their descriptions

Component	Description
(1) 	<p>USB SuperSpeed port with HP Sleep and Charge</p> <p>Connects a USB device, provides high-speed data transfer, and charges small devices, even when the computer is off.</p> <p>- and -</p> <p>Connects a display device that has a USB Type-C connector, providing DisplayPort™ output.</p> <p>NOTE: Cables, adapters, or both (purchased separately) might be required.</p>
(2) 	<p>USB Type-C® Thunderbolt™ port with HP Sleep and Charge</p> <p>Connects a USB device, provides high-speed data transfer, and charges small devices, even when the computer is off.</p> <p>- and -</p> <p>Connects a display device that has a USB Type-C connector, providing DisplayPort output.</p> <p>NOTE: Your computer might also support a Thunderbolt docking station.</p> <p>NOTE: Cables, adapters, or both (purchased separately) might be required.</p>
(3) 	<p>Dual-Mode DisplayPort® connector</p> <p>Connects an optional digital display device, such as a high-performance monitor or projector.</p>
(4)	<p>Vent</p> <p>Enables airflow airflow to cool internal components.</p> <p>NOTE: The computer fan starts up automatically to cool internal components and prevent overheating. It is normal for the internal fan to cycle on and off during routine operation.</p>
(5) 	<p>USB ports (2)</p> <p>Connect USB devices, provide data transfer, and (for select products) charge small devices when the computer is on or in Sleep mode.</p>

Left side

Use the illustration and table to identify the components on the left side of the computer.

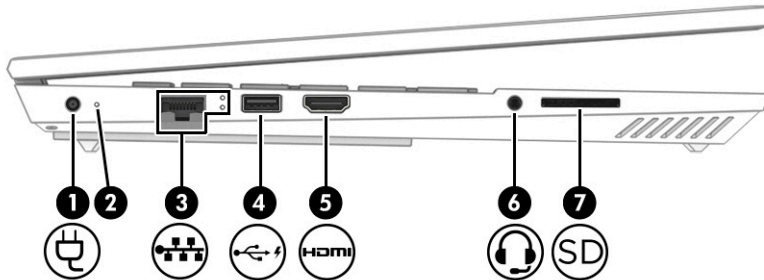

Table 2-2 Left-side components and their descriptions







Component	Description
(1) 	Power connector Connects an AC adapter.
(2) 	AC adapter and battery light <ul style="list-style-type: none"> White: The AC adapter is connected and the battery is fully charged. Blinking white (select products only): The AC adapter is disconnected and the battery has reached a low battery level. Amber: The AC adapter is connected and the battery is charging. Off: The battery is not charging.
(3) 	RJ-45 (network) jack/status lights Connects a network cable. <ul style="list-style-type: none"> White: The network is connected. Amber: Activity is occurring on the network.
(4) 	USB port with HP Sleep and Charge Connects a USB device, provides data transfer, and charges small devices, even when the computer is off.
(5) 	HDMI port Connects an optional video or audio device, such as a high-definition television, any compatible digital or audio component, or a high-speed High-Definition Multimedia Interface (HDMI) device.
(6) 	Audio-out (headphone)/Audio-in (microphone) combo jack Connects optional powered stereo speakers, headphones, earbuds, a headset, or a television audio cable. Also connects an optional headset microphone. This jack does not support optional standalone microphones. <p>WARNING! To reduce the risk of personal injury, adjust the volume before putting on headphones, earbuds, or a headset. For additional safety information, see the <i>Regulatory, Safety, and Environmental Notices</i>.</p> <p>To access this guide:</p> <ul style="list-style-type: none"> ▲ Type <code>HP Documentation</code> in the taskbar search box, and then select HP Documentation.

Table 2-2 Left-side components and their descriptions (continued)

Component	Description
(7) SD Memory card reader	<p>NOTE: When a device is connected to the jack, the computer speakers are disabled.</p> <p>Reads optional memory cards that enable you to store, manage, share, or access information.</p> <p>To insert a card:</p> <ol style="list-style-type: none">1. Hold the card label-side up, with connectors facing the computer.2. Insert the card into the memory card reader, and then press in on the card until it is firmly seated. <p>To remove a card:</p> <ul style="list-style-type: none">▲ Press in on the card, and then remove it from the memory card reader.

Rear

Identify the components on the rear of the computer.

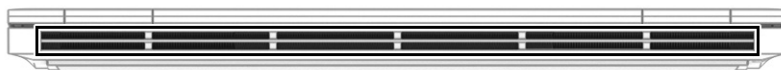

Table 2-3 Rear component and its description

Component	Description
Vent	<p>Enables airflow to cool internal components.</p> <p>NOTE: The computer fan starts up automatically to cool internal components and prevent overheating. It is normal for the internal fan to cycle on and off during routine operation.</p>

Display

The computer display can include essential components such as speakers, antennas, cameras, and microphones.

 **NOTE:** Your computer might look slightly different from the illustration in this section.

Low blue light mode (select products only)

Your computer display is shipped from the factory in low blue light mode for improved eye comfort and safety. Also, blue light mode automatically adjusts blue light emissions when you are using the computer at night or for reading.

 **WARNING!** To reduce the risk of serious injury, read the *Safety & Comfort Guide*. It describes proper workstation setup and proper posture, health, and work habits for computer users. The *Safety & Comfort Guide* also provides important electrical and mechanical safety information. The *Safety & Comfort Guide* is available on the web at <http://www.hp.com/ergo>.

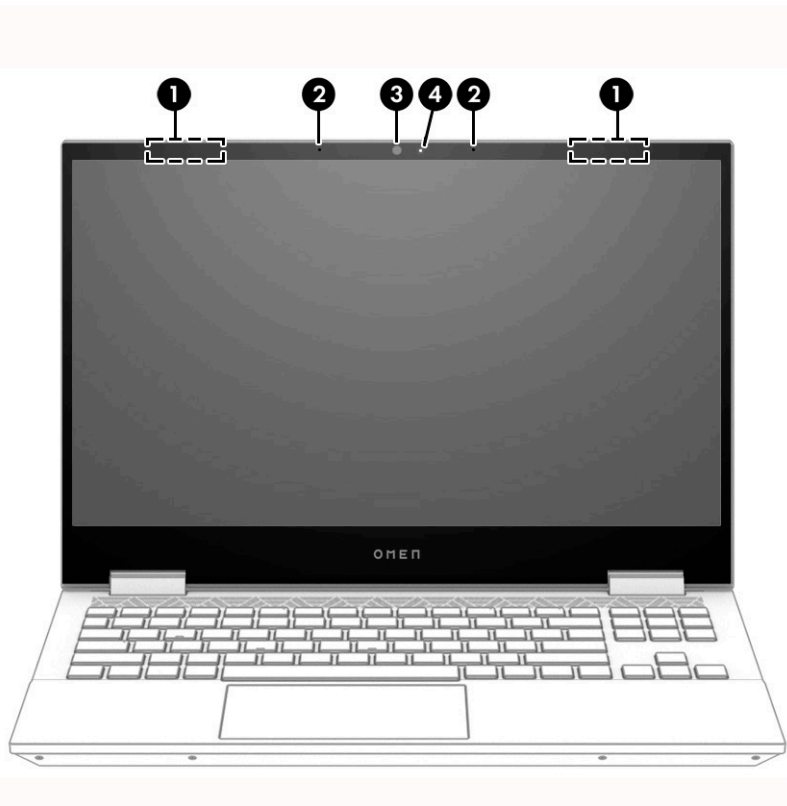

Table 2-4 Display components and their descriptions

Component	Description
(1) WLAN antennas*	Send and receive wireless signals to communicate with wireless local area networks (WLANs).
(2) Internal microphones (2)	Record sound.
(3) Camera	Allows you to video chat, record video, and record still images. Some cameras also allow a facial recognition logon to Windows, instead of a password logon. NOTE: Camera functions vary depending on the camera hardware and software installed on your product.
(4) Camera light	On: The camera is in use.

*The antennas are not visible from the outside of the computer. For optimal transmission, keep the areas immediately around the antennas free from obstructions.

For wireless regulatory notices, see the section of the *Regulatory, Safety, and Environmental Notices* that applies to your country or region.

To access this guide:

- ▲ Type `HP Documentation` in the taskbar search box, and then select **HP Documentation**.

Keyboard area

Keyboards can vary by language.

Touchpad components

Identify the touchpad components.

To adjust touchpad settings and gestures, or to turn off the touchpad:

1. Type **touchpad settings** in the taskbar search box, and then press **enter**.
2. Choose a setting.

To turn on the touchpad:

1. Type **touchpad settings** in the taskbar search box, and then press **enter**.
2. Using an external mouse, click the **touchpad** button.

- or -

- ▲ Press the **Tab** key repeatedly until the pointer rests on the **touchpad** button. Then press the spacebar to select the button.

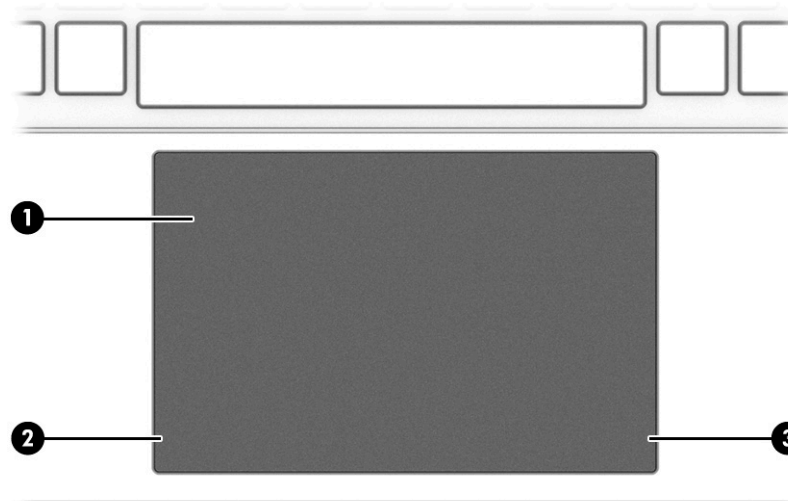

Table 2-5 Touchpad components and their descriptions

Component	Description
(1) Touchpad zone	Reads your finger gestures to move the pointer or activate items on the screen.
(2) Left touchpad button	Functions like the left button on an external mouse.
(3) Right touchpad button	Functions like the right button on an external mouse.

Lights

Identify the lights on the computer.

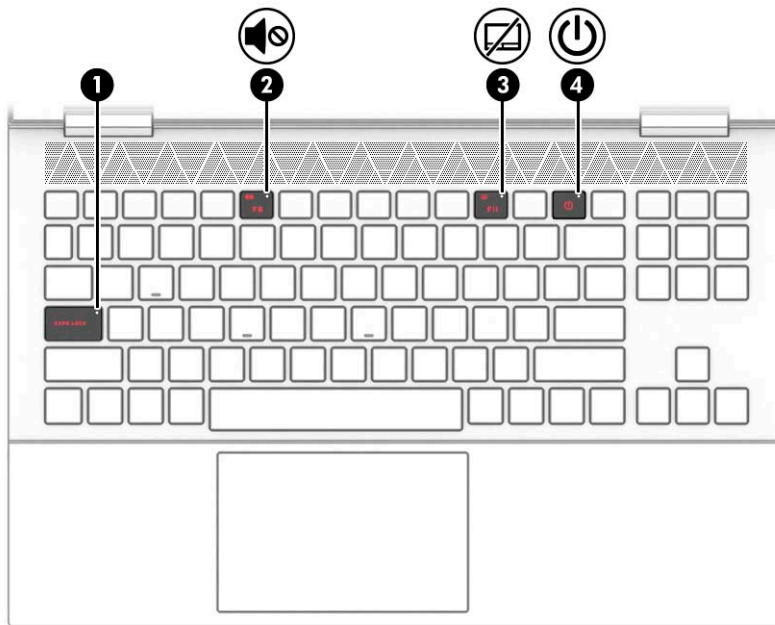





Table 2-6 Lights and their descriptions

Component		Description
(1)	Caps lock light	On: Caps lock is on, which switches the key input to all capital letters.
(2)	 Mute light	<ul style="list-style-type: none"> • On: Computer sound is off. • Off: Computer sound is on.
(3)	 Touchpad light	<ul style="list-style-type: none"> • On: The touchpad is off. • Off: The touchpad is on.
(4)	 Power light	<ul style="list-style-type: none"> • On: The computer is on. • Blinking (select products only): The computer is in the Sleep state, a power-saving state. The computer shuts off power to the display and other unnecessary components. • Off: Depending on your computer model, the computer is off, in Hibernation, or in Sleep. Hibernation is the power-saving state that uses the least amount of power.

Button

Identify the computer button.

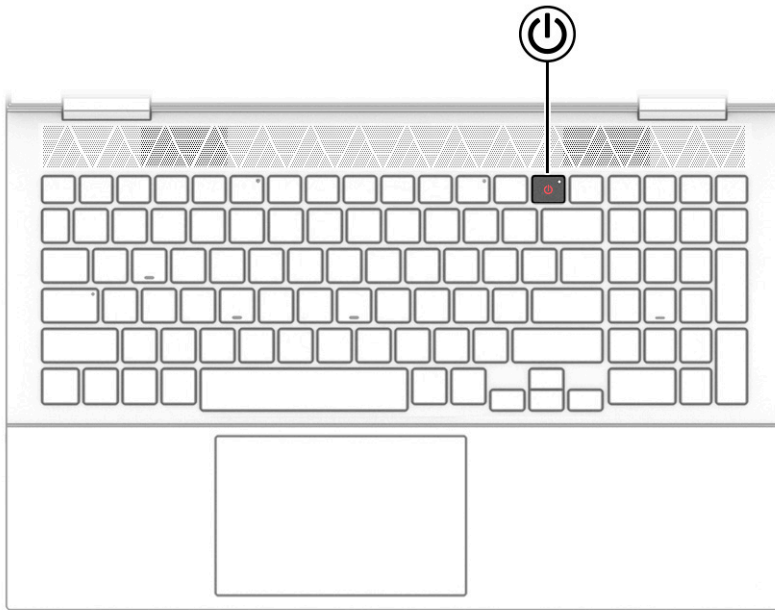



Table 2-7 Button and its description

Component	Description
 Power button	<ul style="list-style-type: none"> • When the computer is off, press the button briefly to turn on the computer. • When the computer is on, press the button briefly to initiate Sleep. • When the computer is in the Sleep state, press the button briefly to exit Sleep (select products only). • When the computer is in Hibernation, press the button briefly to exit Hibernation. <p>IMPORTANT: Pressing and holding down the power button results in the loss of unsaved information.</p> <p>If the computer has stopped responding and shutdown procedures are ineffective, press and hold the power button down for at least 10 seconds to turn off the computer.</p> <p>To learn more about your power settings, see your power options:</p> <ul style="list-style-type: none"> ▲ Right-click the Power icon , and then select Power Options.

Special keys

Identify the special keys.

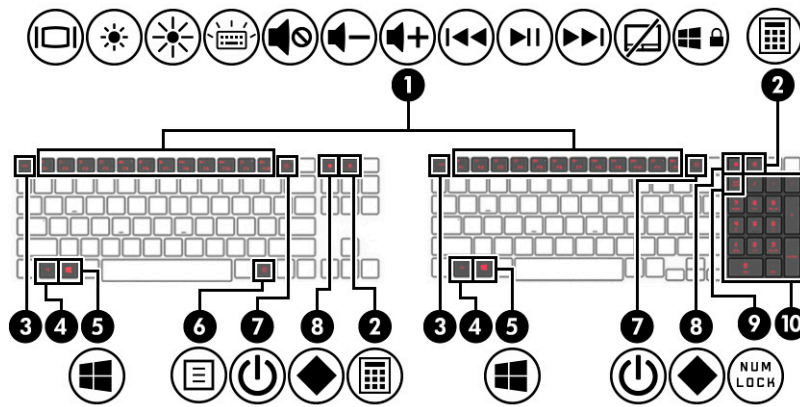

Table 2-8 Special keys and their descriptions







Component	Description
(1) Action keys	Execute frequently used system functions as defined by the icon symbols on f1 through f12 function keys.
(2)  Calculator key	Opens the calculator. NOTE: Pressing the key again closes the calculator.
(3) esc key	Displays system information when pressed in combination with the fn key.
(4) fn key	Executes specific functions when pressed in combination with another key.
(5)  Windows key	Opens the Start menu. NOTE: Pressing the Windows key again will close the Start menu.
(6)  Windows application key	Displays options for a selected object.
(7)  Power button	<ul style="list-style-type: none"> When the computer is off, press the button briefly to turn on the computer. When the computer is on, press the button briefly to initiate Sleep. When the computer is in the Sleep state, press the button briefly to exit Sleep (select products only). When the computer is in Hibernation, press the button briefly to exit Hibernation. <p>IMPORTANT: Pressing and holding down the power button results in the loss of unsaved information.</p> <p>If the computer has stopped responding and shutdown procedures are ineffective, press and hold the power button down for at least 10 seconds to turn off the computer.</p> <p>To learn more about your power settings, see your power options:</p> <ul style="list-style-type: none"> ▲ Right-click the Power icon , and then select Power Options.

Table 2-8 Special keys and their descriptions (continued)

Component	Description
(8)  OMEN key	Opens the OMEN Command Center software.
(9) num lock key	Alternates between the navigational and numeric functions on the integrated numeric keypad.
(10) Integrated numeric keypad	A separate keypad to the right of the alphabet keyboard. When num lock is pressed, the keypad can be used like an external numeric keypad. NOTE: If the keypad function is active when the computer is turned off, that function is reinstated when the computer is turned back on.

Bottom

Identify the bottom components.

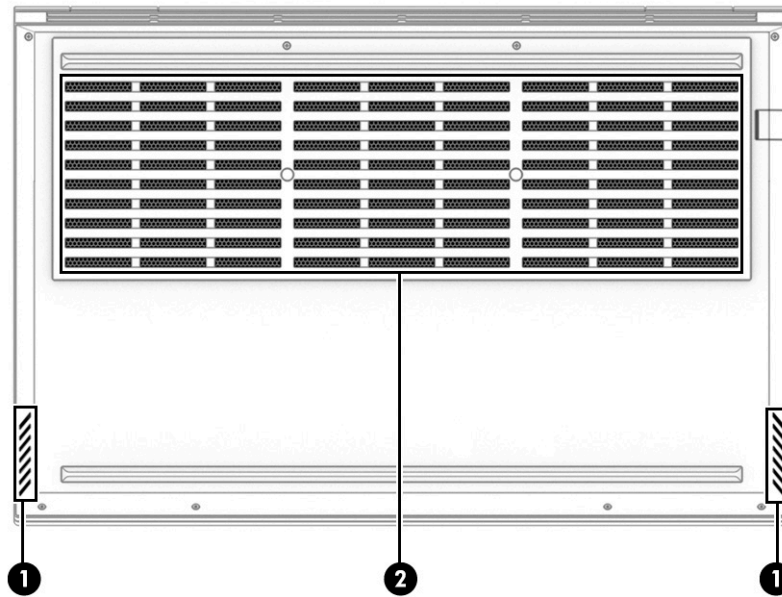



Table 2-9 Bottom components and their descriptions

Component	Description
(1) Speakers (2)	Produce sound.
(2) Vent	Enables airflow to cool internal components. NOTE: The computer fan starts up automatically to cool internal components and prevent overheating. It is normal for the internal fan to cycle on and off during routine operation.

Labels

The labels affixed to the computer provide information that you might need when you troubleshoot system problems or travel internationally with the computer. Labels can be in paper form or imprinted on the product.

 **IMPORTANT:** Check the following locations for the labels described in this section: the bottom of the computer, inside the battery bay, under the service door, on the back of the display, or on the bottom of a tablet kickstand.

- Service label—Provides important information to identify your computer. When contacting support, you might be asked for the serial number, the product number, or the model number. Locate this information before you contact support.

Your service label information order may vary by country and might not include the wording "Model" due to the country regulation.

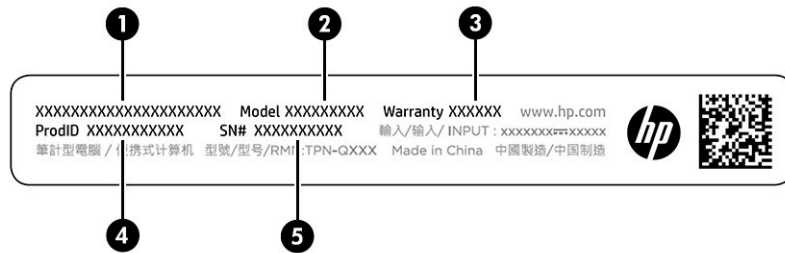

Table 2-10 Service label components

Component	
(1)	HP product name
(2)	Model number
(3)	Warranty period
(4)	Product ID
(5)	Serial number

- Regulatory label(s)—Provide(s) regulatory information about the computer.
- Wireless certification label(s)—Provide(s) information about optional wireless devices and the approval markings for the countries or regions in which the devices have been approved for use.

HP OMEN Command Center

HP OMEN Command Center allows you to customize your computer for your specific gaming needs.

- ▲ To open HP OMEN Command Center, select the Start button, select OMEN Command Center, and then follow the on-screen instructions.

- or -

Press the OMEN  key at the top right side of the keyboard.

The HP OMEN Command Center dashboard provides a central location to access and configure the following features:

 **NOTE:** Some features are available on select products only.

- **System Vitals:** Monitor the computer status and performance.
- **Lighting:** Customize the keyboard and OMEN logo lighting (select products only).
- **Network Booster:** View and adjust network priorities and settings.
- **Performance Control:** Optimize the performance of your computer for the task you are performing.
- **Gaming Device Lighting and Macros:** Configure the lighting and macro keys when an external supported gaming device is connected (select products only).
- **My Games:** Manage and access your game library from one location.
- **OMEN Game Stream:** Provide the ability to stream games to other devices.
- **Help:** Access “How to” information and frequently asked questions.



NOTE: To minimize the dashboard, select the arrow button < at the top of the dashboard.

3 Illustrated parts catalog

Use this table to determine the spare parts that are available for the computer.

Computer major components

To identify the computer major components, use this illustration and table.

 **NOTE:** HP continually improves and changes product parts. For complete and current information about supported parts for your computer, go to <http://partsurfer.hp.com>, select your country or region, and then follow the on-screen instructions.

 **NOTE:** Details about your computer, including model, serial number, product key, and length of warranty, are on the service tag at the bottom of your computer.

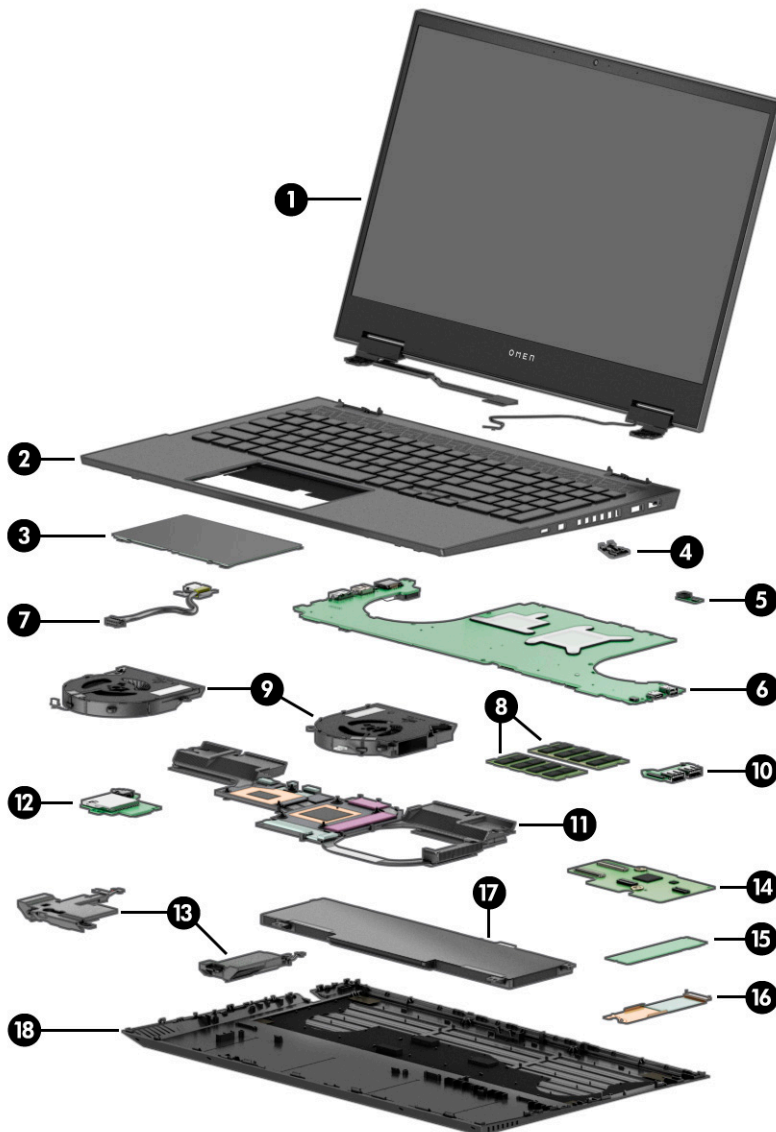

Table 3-1 Computer major component descriptions and part numbers

Item	Component	Spare part number
(1)	Display panel assembly NOTE: Display panels are only available as spare parts at a subcomponent level.	not available as a spare part
(2)	Top cover/keyboard NOTE: For a detailed list of keyboard country codes, see Keyboard with top cover on page 62	
	Models without Thunderbolt:	
	<ul style="list-style-type: none"> Dragon red legend keyboard, 1-zone lighting 	L98943-001
	<ul style="list-style-type: none"> White legend keyboard, RGB 4-zone lighting 	L98944-001
	<ul style="list-style-type: none"> White legend keyboard, RGB, per key lighting 	L98945-001
	<ul style="list-style-type: none"> Dragon red legend keyboard, 1-zone lighting, with numeric keypad 	L98946-001
	<ul style="list-style-type: none"> White legend keyboard, RGB 4-zone lighting, with numeric keypad 	L98947-001
	Models with Thunderbolt:	
	<ul style="list-style-type: none"> Dragon red legend keyboard, 1-zone lighting 	M00838-001
	<ul style="list-style-type: none"> White legend keyboard, RGB per key lighting 	M00839-001
	<ul style="list-style-type: none"> White legend keyboard, RGB, 4-zone lighting 	M00840-001
	<ul style="list-style-type: none"> Dragon red legend keyboard, 1-zone lighting, with numeric keypad 	M00841-001
	<ul style="list-style-type: none"> White legend keyboard, RGB 4-zone lighting, with numeric keypad 	M00842-001
(3)	Touchpad NOTE: The touchpad cable is available as spare part number L98730-001.	L98745-001
(4)	RJ-45 door	
	For use in models with GeForce GTX 1660, 1660Ti, and RTX graphics cards	L98959-001
	For use in models with GeForce GTX 1650, 1650Ti graphics cards	L99533-001
(5)	IR board NOTE: The IR board cable is available as spare part number L98726-001.	L98743-001
(6)	System board (includes integrated processor and replacement thermal material) All system boards use the following part numbers: xxxxxx-001: Non-Windows operating system xxxxxx-601: Windows 10 operating system	
	Intel Core i7-10750H processor and GeForce RTX 2070S, 8 GB graphics card	L98756-xx1
	Intel Core i7-10750H processor and GeForce RTX 2070S, 8 GB graphics card and an OLED display	L98758-xx1
	Intel Core i7-10750H processor and GeForce RTX 2070, 8 GB graphics card	L98755-xx1
	Intel Core i7-10750H processor and GeForce RTX 2070, 8 GB graphics card and an OLED display	M05057-xx1
	Intel Core i7-10750H processor and GeForce RTX 2060, 6 GB graphics card	M00123-xx1
	Intel Core i7-10750H processor and GeForce RTX 2060, 6 GB graphics card and an OLED display	M00124-xx1
	Intel Core i7-10750H processor and GeForce GTX 1660Ti, 6 GB graphics card	L98750-xx1

Table 3-1 Computer major component descriptions and part numbers (continued)

Item	Component	Spare part number
	Intel Core i7-10750H processor and GeForce GTX 1650Ti, 4 GB graphics card	L98753-xx1
	Intel Core i5-10300H processor and GeForce RTX 2070, 8 GB graphics card	L98754-xx1
	Intel Core i5-10300H processor and GeForce RTX 2060, 6 GB graphics card	M00122-xx1
	Intel Core i5-10300H processor and GeForce GTX 1660Ti, 6 GB graphics card	L98749-xx1
	Intel Core i5-10300H processor and GeForce GTX 1650Ti, 4 GB graphics card	L98752-xx1
	Intel Core i5-10300H processor and GeForce GTX 1650, 4 GB graphics card	L98751-xx1
(7)	Power connector cable	L98734-001
(8)	Memory modules (DDR4-3200)	
	16 GB	L67710-001
	8 GB	L46598-001
	4 GB	L83673-001
(9)	Fans (includes left and right fans)	
	For use in models with GeForce GTX 1660, 1660Ti, and RTX graphics cards	L98737-001
	For use in models with GeForce GTX 1650, 1650Ti graphics cards	L98738-001
(10)	USB board	L98742-001
	NOTE: The USB board cable is available as spare part number L98725-001.	
(11)	Heat sink assembly (includes replacement thermal material)	
	For use in models with GeForce GTX 1660, 1660Ti, and RTX graphics cards	L98735-001
	NOTE: The heat sink thermal pad kit is available as spare part number L98955-001.	
	For use in models with GeForce GTX 1650, 1650Ti graphics cards	L98736-001
	NOTE: The heat sink thermal pad kit is available as spare part number M00753-001.	
(12)	Card reader/audio board	L98744-001
	NOTE: The card reader/audio board cable is available as spare part number L98727-001.	
(13)	Speakers (left and right)	L98748-001
(14)	RGB board	L98746-001
	NOTE: The RGB board cable is available as spare part number L98728-001. The RGB board LED cable is available as spare part number L98729-001.	
(15)	Solid-state drive (M.2, PCIe, TLC)	
	NOTE: The solid-state drive thermal pad is available as spare part number L98956-001.	
	1 TB	L85348-001
	512 GB	L85360-001
	512 GB + 32 GB Optane memory module	L85366-001
	256 GB	L85350-001
(16)	Solid-state drive bracket	not available as a spare part

Table 3-1 Computer major component descriptions and part numbers (continued)

Item	Component	Spare part number
(17)	Battery	
	6 cell, 70 Wh	L84392-006
	3 cell, 52 Wh	L84394-006
(18)	Bottom cover	
	For use in models with GeForce GTX 1650, 1650Ti graphics cards	L98724-001
	For use in models with GeForce GTX 1660, 1660Ti, and RTX graphics cards	L98723-001

Display assembly subcomponents

To identify the display assembly subcomponents, use this illustration and table.

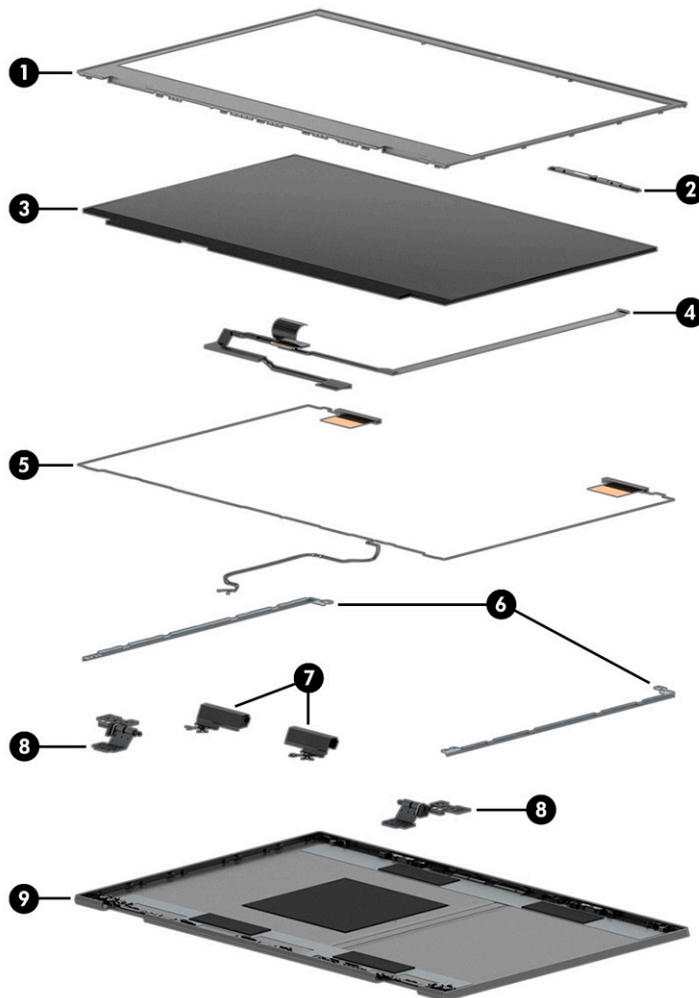

Table 3-2 Display component descriptions and part numbers

Item	Component	Spare part number
(1)	Display bezel	L99532-001

Table 3-2 Display component descriptions and part numbers (continued)

Item	Component	Spare part number
	NOTE: Bezel adhesive is available as spare part number L98957-001.	
(2)	Camera module (includes bezel adhesive and display back cover adhesive)	L98760-001
(3)	Display panel (includes bezel adhesive and display back cover adhesive)	
	FHD, 250 nits, 3.2 mm	L99597-001
	FHD, 300 nits, 2.6 mm	L99598-001
	FHD, 144 Hz, 2.6 mm	L99600-001
	FHD, 300 Hz, 2.6 mm	L99601-001
	FHD, 144 Hz, flat, 3.2 mm	M12468-001
	UHD, 120 Hz, 2.6 mm	L99602-001
	UHD, OLED	M01025-001
(4)	Display/camera cable (includes bezel adhesive and display back cover adhesive)	
	For use with FHD displays	L98733-001
	For use with UHD 120 HZ/144 Hz displays	L98732-001
	For use with UHD, OLED displays	M01024-001
(5)	Wireless antennas and cables	L98720-001
(6)	Display brackets	not available as a spare part
(7)	Hinge covers (left and right, includes bezel adhesive and display back cover adhesive)	L98741-001
(8)	Hinges (left and right, includes bezel adhesive and display back cover adhesive)	L98740-001
(9)	Display back cover (includes antennas and bezel adhesive)	
	NOTE: Display back cover adhesive is available as spare part number L98958-001.	
	For use in models with a 2.6 mm display panel	L98721-001
	For use in models with a 3.2 mm display panel	L98722-001
	For use in models with an OLED display	M01023-001

Cables

To identify the cables, use this illustration and table.

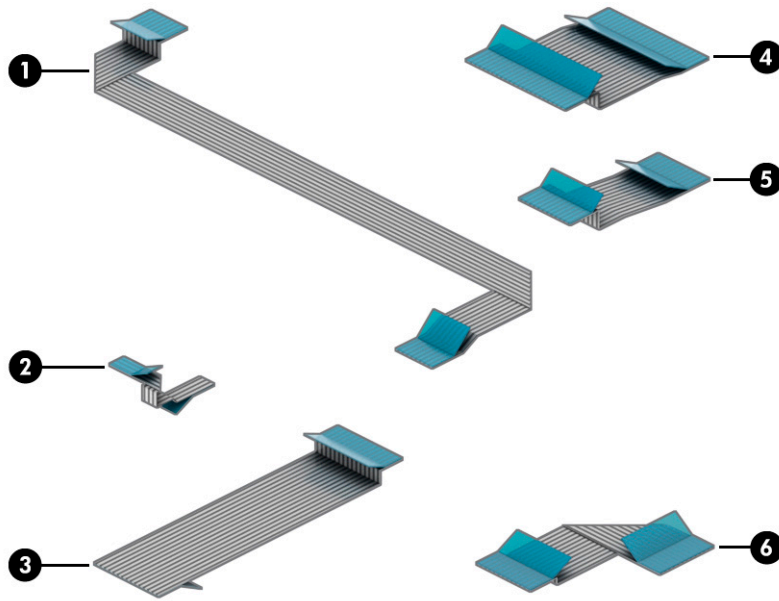

Table 3-3 Cable descriptions and part numbers

Item	Component	Spare part number
(1)	Touchpad cable	L98730-001
(2)	IR board cable	L98726-001
(3)	USB board cable	L98725-001
(4)	RGB board cable	L98728-001
(5)	RGB board LED cable	L98729-001
(6)	Card reader/audio board cable	L98727-001

Miscellaneous parts

To identify the miscellaneous parts, use this illustration and table.

Table 3-4 Miscellaneous part descriptions and part numbers

Component	Spare part number
AC adapter (Smart, PRF, slim, 4.5 mm)	
200 W	L00818-850
150 W	L32661-001
HP HDMI to VGA Adapter	701943-001
Hub	
HP USB-C to USB-A hub	916838-001
HP USB-C to multiport hub	919666-001

Table 3-4 Miscellaneous part descriptions and part numbers (continued)

Component	Spare part number
HP Elite USB-C Multi Port Hub	L39572-001
HP USB External DVD-RW Drive	747080-001
Screw Kit	L98747-001
Power cord (C5, 1.0 m [3.3 ft], straight)	
Argentina	L30811-001
Australia	L22327-001
Denmark	L22322-001
Europe (Austria, Belgium, Finland, France, Germany, the Netherlands, Norway, and Sweden)	L22321-001
India	L22624-001
Israel	L22323-001
Italy	L30813-001
Japan	L22330-001
North America	L22319-001
People's Republic of China	L21930-001
South Africa	L22325-001
South Korea	L22328-001
Switzerland	L22324-001
Taiwan	L22329-001
Thailand	L22326-001
United Kingdom	L22320-001
Power cord (C13, 1.0 m [3.3 ft], straight)	
Argentina	L22104-001
Australia	L22339-001
Denmark	L22334-001
Europe (Austria, Belgium, Finland, France, Germany, the Netherlands, Norway, and Sweden)	L22333-001
India	L22343-001
Israel	L22335-001
Italy and Chile	L22103-001
Japan	L22344-001
North America	L22331-001
People's Republic of China	L22341-001
South Africa	L22337-001
South Korea	L22340-001

Table 3-4 Miscellaneous part descriptions and part numbers (continued)

Component	Spare part number
Switzerland	L22336-001
Taiwan	L22342-001
Thailand	L22338-001
United Kingdom	L22332-001

4 Removal and replacement procedures preliminary requirements

Use this information to properly prepare to disassemble and reassemble the computer.

Tools required

You need the following tools to complete the removal and replacement procedures:

- Tweezers
- Nonconductive, nonmarking pry tool
- Magnetic Phillips P1 screwdriver

Service considerations

The following sections include some of the considerations that you must keep in mind during disassembly and assembly procedures.

 **NOTE:** As you remove each subassembly from the computer, place the subassembly (and all accompanying screws) away from the work area to prevent damage.

Plastic parts

Using excessive force during disassembly and reassembly can damage plastic parts.

Cables and connectors

Handle cables with extreme care to avoid damage.

 **IMPORTANT:** When servicing the computer, be sure that cables are placed in their proper locations during the reassembly process. Improper cable placement can damage the computer.

Apply only the tension required to unseat or seat the cables during removal and insertion. Handle cables by the connector whenever possible. In all cases, avoid bending, twisting, or tearing cables. Be sure that cables are routed so that they cannot be caught or snagged as you remove or replace parts. Handle flex cables with extreme care; these cables tear easily.

Drive handling

Note the following guidelines when handling drives.



IMPORTANT: Drives are fragile components. Handle them with care. To prevent damage to the computer, damage to a drive, or loss of information, observe these precautions:

Before removing or inserting a hard drive, shut down the computer. If you are unsure whether the computer is off or in Hibernation, turn the computer on, and then shut it down through the operating system.

Before handling a drive, be sure that you are discharged of static electricity. While handling a drive, avoid touching the connector.

Before removing an optical drive, be sure that a disc is not in the drive, and be sure that the optical drive tray is closed.

Handle drives on surfaces covered with at least 2.54 cm (1 inch) of shock-proof foam.

Avoid dropping drives from any height onto any surface.

After removing a hard drive or an optical drive, place it in a static-proof bag.

Avoid exposing an internal hard drive to products that have magnetic fields, such as monitors or speakers.

Avoid exposing a drive to temperature extremes or liquids.

If a drive must be mailed, place the drive in a bubble pack mailer or other suitable form of protective packaging, and label the package “FRAGILE.”

Workstation guidelines

Follow these grounding workstation guidelines:

- Cover the workstation with approved static-shielding material.
- Use a wrist strap connected to a properly grounded work surface and use properly grounded tools and equipment.
- Use conductive field service tools, such as cutters, screw drivers, and vacuums.
- When fixtures must directly contact dissipative surfaces, use fixtures made only of static-safe materials.
- Keep the work area free of nonconductive materials, such as ordinary plastic assembly aids and polystyrene foam.
- Handle ESD-sensitive components, parts, and assemblies by the case or PCM laminate. Handle these items only at static-free workstations.
- Avoid contact with pins, leads, or circuitry.
- Turn off power and input signals before inserting or removing connectors or test equipment.

Electrostatic discharge information

A sudden discharge of static electricity from your finger or other conductor can destroy static-sensitive devices or microcircuitry. Often the spark is neither felt nor heard, but damage occurs. An electronic device exposed to electrostatic discharge (ESD) might not appear to be affected at all and can work perfectly throughout a normal cycle. The device might function normally for a while, but it has been degraded in the internal layers, reducing its life expectancy.

Networks built into many integrated circuits provide some protection, but in many cases, the discharge contains enough power to alter device parameters or melt silicon junctions.



IMPORTANT: To prevent damage to the device when you remove or install internal components, observe these precautions:

Keep components in their electrostatic-safe containers until you are ready to install them.

Before touching an electronic component, discharge static electricity by using the guidelines described [Personal grounding methods and equipment on page 28](#).

Avoid touching pins, leads, and circuitry. Handle electronic components as little as possible.

If you remove a component, place it in an electrostatic-safe container.

Generating static electricity

Follow these static electricity guidelines.

- Different activities generate different amounts of static electricity.
- Static electricity increases as humidity decreases.

Table 4-1 Static electricity occurrence based on activity and humidity

Event	Relative humidity		
	55%	40%	10%
Walking across carpet	7,500 V	15,000 V	35,000 V
Walking across vinyl floor	3,000 V	5,000 V	12,000 V
Motions of bench worker	400 V	800 V	6,000 V
Removing DIPs (dual in-line packages) from plastic tube	400 V	700 V	2,000 V
Removing DIPs from vinyl tray	2,000 V	4,000 V	11,500 V
Removing DIPs from polystyrene foam	3,500 V	5,000 V	14,500 V
Removing bubble pack from PCB (printed circuit board)	7,000 V	20,000 V	26,500 V
Packing PCBs in foam-lined box	5,000 V	11,000 V	21,000 V

Multiple electric components can be packaged together in plastic tubes, trays, or polystyrene foam.



NOTE: As little as 700 V can degrade a product.

Preventing electrostatic damage to equipment

Many electronic components are sensitive to ESD. Circuitry design and structure determine the degree of sensitivity. The following packaging and grounding precautions are necessary to prevent static electricity damage to electronic components.

- To avoid hand contact, transport products in static-safe containers such as tubes, bags, or boxes.
- Protect all electrostatic parts and assemblies with conductive or approved containers or packaging.
- Keep electrostatic-sensitive parts in their containers until they arrive at static-free stations.
- Place items on a grounded surface before removing them from their container.
- Always be properly grounded when touching a sensitive component or assembly.

- Avoid contact with pins, leads, or circuitry.
- Place reusable electrostatic-sensitive parts from assemblies in protective packaging or conductive foam.

Personal grounding methods and equipment

Using certain equipment can prevent static electricity damage to electronic components.

- **Wrist straps** are flexible straps with a maximum of $1\text{ M}\Omega \pm 10\%$ resistance in the ground cords. To provide proper ground, a strap must be worn snug against bare skin. The ground cord must be connected and fit snugly into the banana plug connector on the grounding mat or workstation.
- **Heel straps/Toe straps/Boot straps** can be used at standing workstations and are compatible with most types of shoes or boots. On conductive floors or dissipative floor mats, use them on both feet with a maximum of $1\text{ M}\Omega \pm 10\%$ resistance between the operator and ground.

Table 4-2 Static shielding protection levels

Static shielding protection levels	
Method	Voltage
Antistatic plastic	1,500
Carbon-loaded plastic	7,500
Metallized laminate	15,000

Grounding the work area

To prevent static damage at the work area, follow these precautions.

- Cover the work surface with approved static-dissipative material. Provide a wrist strap connected to the work surface and properly grounded tools and equipment.
- Use static-dissipative mats, foot straps, or air ionizers to give added protection.
- Handle electrostatic sensitive components, parts, and assemblies by the case or PCB laminate. Handle them only at static-free work areas.
- Turn off power and input signals before inserting and removing connectors or test equipment.
- Use fixtures made of static-safe materials when fixtures must directly contact dissipative surfaces.
- Keep work area free of nonconductive materials such as ordinary plastic assembly aids and polystyrene foam.
- Use field service tools, such as cutters, screwdrivers, and vacuums, that are conductive.

Recommended materials and equipment

HP recommends certain materials and equipment to prevent static electricity.

- Antistatic tape
- Antistatic smocks, aprons, or sleeve protectors
- Conductive bins and other assembly or soldering aids
- Conductive foam
- Conductive tabletop workstations with ground cord of $1\text{ M}\Omega \pm 10\%$ resistance

- Static-dissipative table or floor mats with hard tie to ground
- Field service kits
- Static awareness labels
- Wrist straps and footwear straps providing $1\text{ M}\Omega \pm 10\%$ resistance
- Material handling packages
- Conductive plastic bags
- Conductive plastic tubes
- Conductive tote boxes
- Opaque shielding bags
- Transparent metallized shielding bags
- Transparent shielding tubes

Packaging and transporting guidelines

Follow these grounding guidelines when packaging and transporting equipment.

- To avoid hand contact, transport products in static-safe tubes, bags, or boxes.
- Protect ESD-sensitive parts and assemblies with conductive or approved containers or packaging.
- Keep ESD-sensitive parts in their containers until the parts arrive at static-free workstations.
- Place items on a grounded surface before removing items from their containers.
- Always be properly grounded when touching a component or assembly.
- Store reusable ESD-sensitive parts from assemblies in protective packaging or nonconductive foam.
- Use transporters and conveyors made of antistatic belts and roller bushings. Be sure that mechanized equipment used for moving materials is wired to ground and that proper materials are selected to avoid static charging. When grounding is not possible, use an ionizer to dissipate electric charges.

5 Removal and replacement procedures for Customer Self-Repair parts

This chapter provides removal and replacement procedures for Customer Self-Repair parts.

 **NOTE:** The Customer Self-Repair program is not available in all locations. Installing a part that is not supported by the Customer Self-Repair program can void your warranty. Check your warranty to determine whether Customer Self-Repair is supported in your location.

Component replacement procedures

To remove and replace computer components, use these procedures.

 **NOTE:** Details about your computer, including model, serial number, product key, and length of warranty, are on the service tag at the bottom of your computer.

 **NOTE:** HP continually improves and changes product parts. For complete and current information about supported parts for your computer, go to <http://partsurfer.hp.com>, select your country or region, and then follow the on-screen instructions.

You must remove, replace, or loosen as many as 14 screws when you service Customer Self-Repair parts. Make special note of each screw size and location during removal and replacement.

Preparation for disassembly

To prepare to disassemble the computer, use these steps.

See [Removal and replacement procedures preliminary requirements on page 25](#) for initial safety procedures.

1. Turn off the computer. If you are unsure whether the computer is off or in Hibernation, turn the computer on, and then shut it down through the operating system.
2. Disconnect the power from the computer by unplugging the power cord from the computer.
3. Disconnect all external devices from the computer.

Bottom cover

To remove the bottom cover, use this procedure and illustration.

Table 5-1 Bottom cover description and part number

Description	Spare part number
Bottom cover for use in models with GeForce GTX 1650, 1650Ti graphics cards	L98724-001
Bottom cover for use in models with GeForce GTX 1660, 1660Ti, and RTX graphics cards	L98723-001

Before removing the bottom cover, prepare the computer for disassembly ([Preparation for disassembly on page 31](#)).

Remove the bottom cover:

1. Remove the eight Phillips M2.0 × 6.0 screws that secure the bottom cover to the computer..

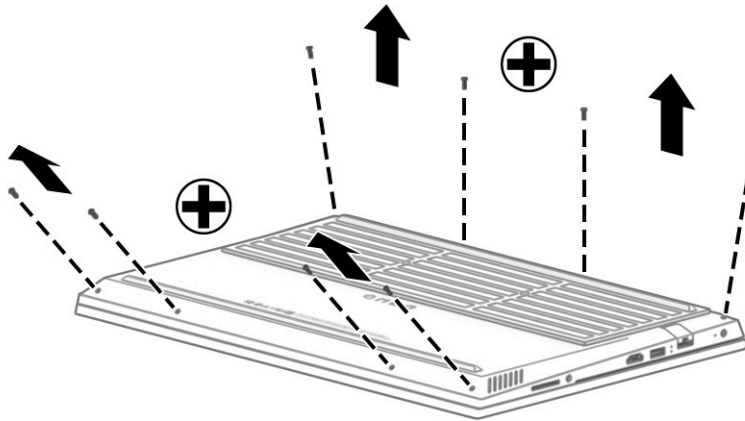

2. Use a tool (1) to release the bottom cover near the display (2), and then remove the bottom cover from the computer (3).

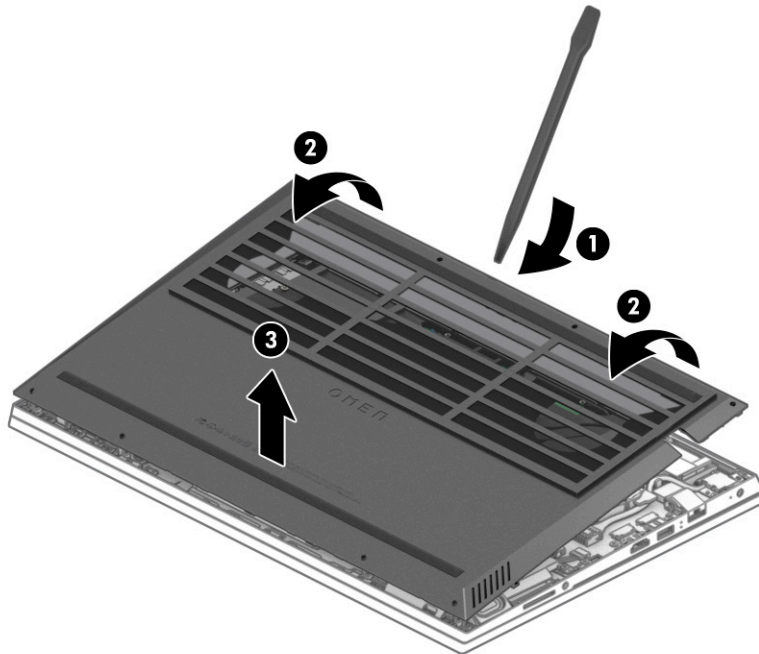

To replace the bottom cover, reverse the removal procedures.

Solid-state drive

To remove the solid-state drive, use this procedure and illustration.

The computer has two solid-state drive sockets. Both sockets have a cover installed on the top of the drive. The cover and drive to the left of the battery covers one of the battery screws. You have to remove the cover and drive to access the battery screw.

Table 5-2 Solid-state drive descriptions and part numbers

Description	Spare part number
1 TB, PCIe, TLC	L85348-001
512 GB, PCIe, TLC	L85360-001
512 GB solid-state drive + 32 GB Optane memory module	L85366-001
256 GB, PCIe, TLC	L85350-001
Solid-state drive thermal pad	L98956-001

Before removing the solid-state drive, follow these steps:

1. Prepare the computer for disassembly ([Preparation for disassembly on page 31](#)).
2. Remove the bottom cover ([Bottom cover on page 31](#)).
3. Disconnect the battery cable from the system board ([Battery on page 37](#)).

Remove the solid-state drive:

 **NOTE:** Use the same procedure to remove both solid-state drives.

1. Remove the Phillips M2.0 × 5.0 screw that secures the drive to the computer **(1)**.
2. Lift the drive to a 45° angle **(2)**, and then remove the cover from the drive **(3)**.
3. Pull the drive away to remove it from the socket **(4)**.

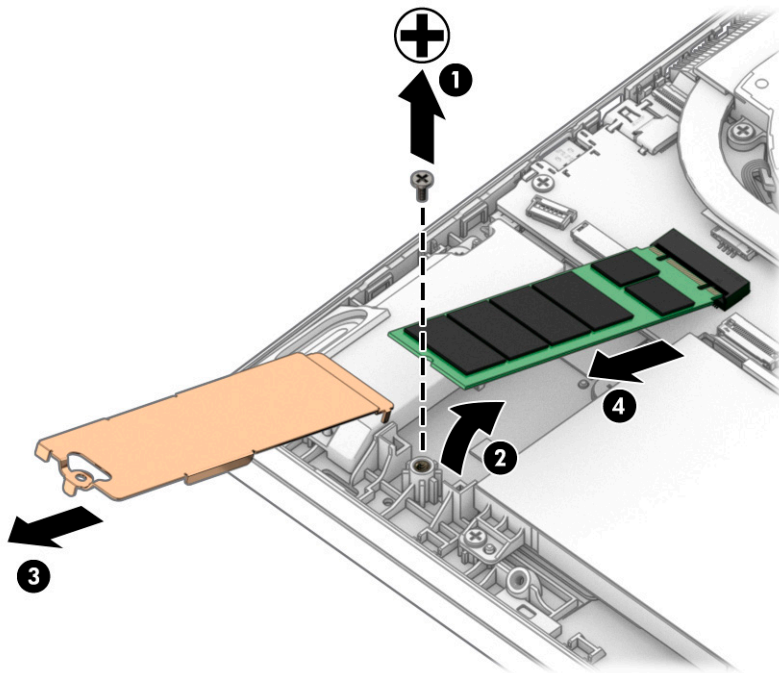

To install the solid-state drive, reverse the removal procedures.

When installing a new solid-state drive, be sure to install the thermal pad to the inside of the cover.

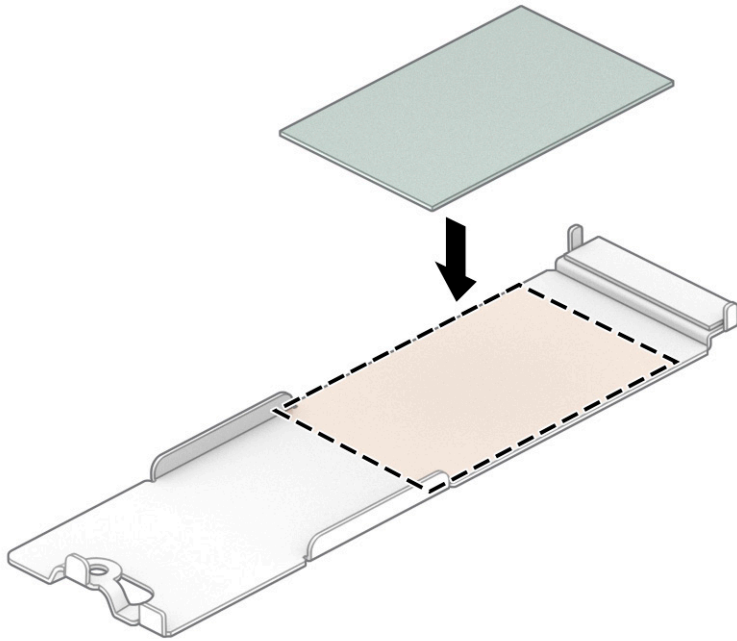

 **NOTE:** Solid-state drives are designed with a notch to prevent incorrect insertion.

Memory modules

To remove the memory modules, use this procedure and illustration.

Table 5-3 Memory module descriptions and part numbers

Description	Spare part number
16 GB, DDR4-3200	L67710-001
8 GB, DDR4-3200	L46598-001
4 GB, DDR4-3200	L83673-001

Before removing a memory module, follow these steps:

1. Prepare the computer for disassembly ([Preparation for disassembly on page 31](#)).
2. Remove the bottom cover ([Bottom cover on page 31](#)).
3. Remove the solid-state drive to the left of the battery ([Solid-state drive on page 32](#)).
4. Remove the battery (see [Battery on page 37](#)).

If you are replacing a memory module, remove the existing memory module:

- ▲ Spread the two retention clips outward **(1)** until the memory module tilts up at a 45° angle, and then remove the module **(2)**. Use the same procedure to remove all memory modules.

 **IMPORTANT:** To prevent damage to the memory module, hold the memory module by the edges only. Do not touch the components on the memory module.

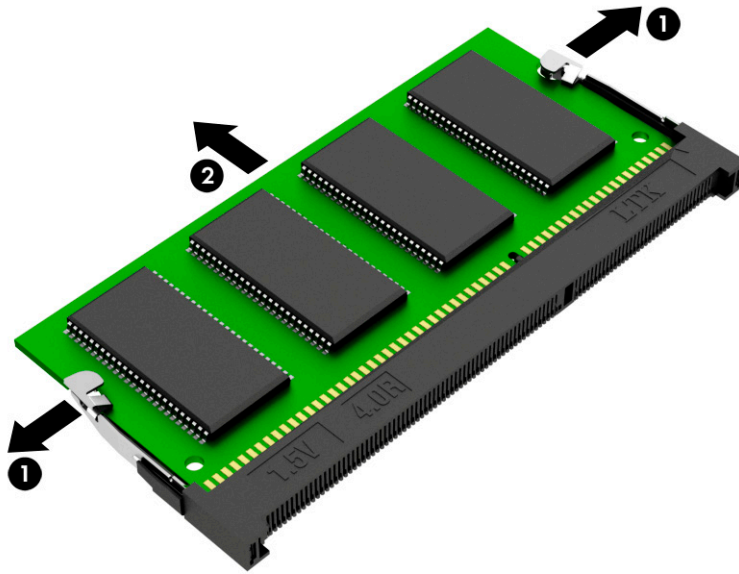

 **NOTE:** To protect a memory module after removal, place it in an electrostatic-safe container.

To install a memory module:

1. Align the notched edge of the module with the tab in the slot **(1)**, and then press the module into the slot at an angle until it is seated **(2)**.
2. Press down on the module until the side retention clips snap into place **(3)**.

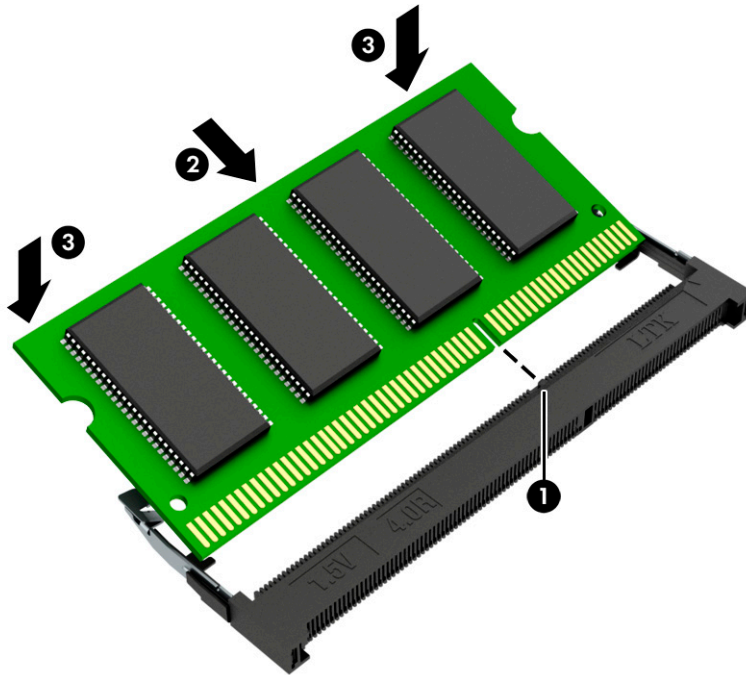

6 Removal and replacement procedures for authorized service provider parts

This chapter provides removal and replacement procedures for authorized service provider parts.

 **IMPORTANT:** Components described in this chapter should be accessed only by an authorized service provider. Accessing these parts can damage the computer or void the warranty.

 **NOTE:** Details about your computer, including model, serial number, product key, and length of warranty, are on the service tag at the bottom of your computer.

Component replacement procedures

To remove and replace computer components, use these procedures.

 **NOTE:** HP continually improves and changes product parts. For complete and current information about supported parts for your computer, go to <http://partsurfer.hp.com>, select your country or region, and then follow the on-screen instructions.

You must remove, replace, or loosen as many as 56 screws when you service the parts described in this chapter. Make special note of each screw size and location during removal and replacement.

Battery

To remove the battery, use this procedure and illustration.

Table 6-1 Battery description and part number

Description	Spare part number
Battery, 6 cell, 70 Wh	L84392-006
Battery, 3 cell, 52 Wh	L84394-006

 **WARNING!** To avoid personal injury and damage to the product:

- Do *not* puncture, twist, or crack the battery.
- Do *not* cause an external puncture or rupture to the battery. They can cause a short inside the battery, which can result in battery thermal runaway.
- Do *not* handle or touch the battery enclosure with sharp objects such as tweezers or pliers, which might puncture the battery.
- Do *not* compress or squeeze the battery case with tools or heavy objects stacked on top of the case. These actions can apply undue force on the battery.
- Do *not* touch the connectors with any metallic surface or object, such as metal tools, screws, or coins, which can cause shorting across the connectors.

Before removing the battery, follow these steps:

1. Prepare the computer for disassembly ([Preparation for disassembly on page 31](#)).
2. Remove the bottom cover ([Bottom cover on page 31](#)).
3. Remove the solid-state drive to the left of the battery ([Solid-state drive on page 32](#)).

WARNING! To reduce potential safety issues, use only the user-replaceable battery provided with the computer, a replacement battery provided by HP, or a compatible battery purchased from HP.

IMPORTANT: Removing a user-replaceable battery that is the sole power source for the computer can cause loss of information. To prevent loss of information, save your work or shut down the computer through Windows before you remove the battery.

Remove the battery:

1. Disconnect the battery cable from the system board (1).
2. Remove the five Phillips M2.0 × 5.0 screw (2) that secure the battery to the computer.
3. Remove the battery from the computer (3).

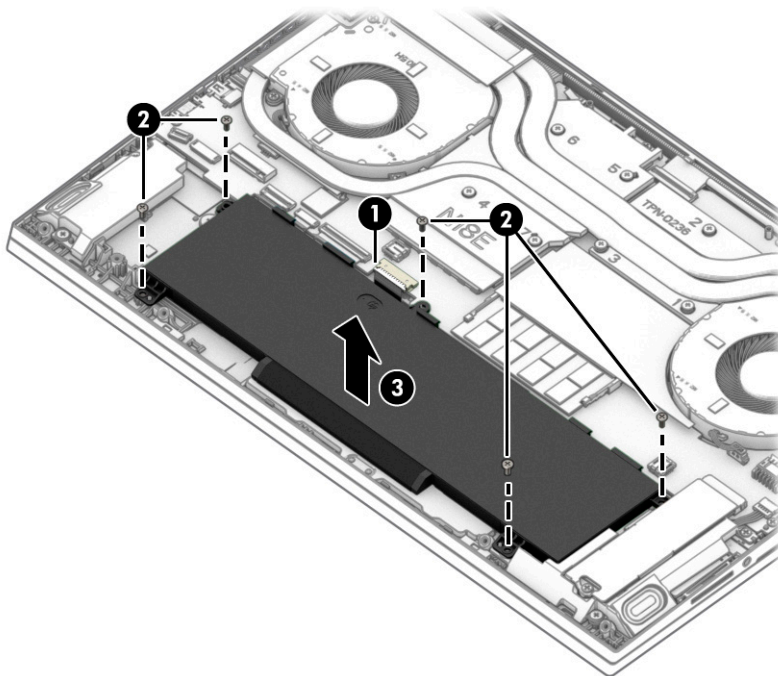

To insert the battery, reverse the removal procedures.

RGB keyboard control board (select products only)

To remove the RGB keyboard control board, use this procedure and illustration.

Table 6-2 RGB keyboard control board description and part number

Description	Spare part number
RGB keyboard control board	L98746-001
RGB keyboard control board cable	L98728-001
RGB keyboard control board LED cable	L98729-001

Before removing the RGB board, follow these steps:

1. Prepare the computer for disassembly ([Preparation for disassembly on page 31](#)).
2. Remove the bottom cover ([Bottom cover on page 31](#)).
3. Remove the solid-state drive to the left of the battery ([Solid-state drive on page 32](#)).
4. Remove the battery (see [Battery on page 37](#)).

Remove the RGB board:

1. Disconnect the four cables from the ZIF connectors on the RGB board **(1)–(4)**.
2. Remove the two Phillips M2.0 × 4.0 screws **(5)** that secure the board to the computer.
3. Remove the RGB board from the computer **(6)**.

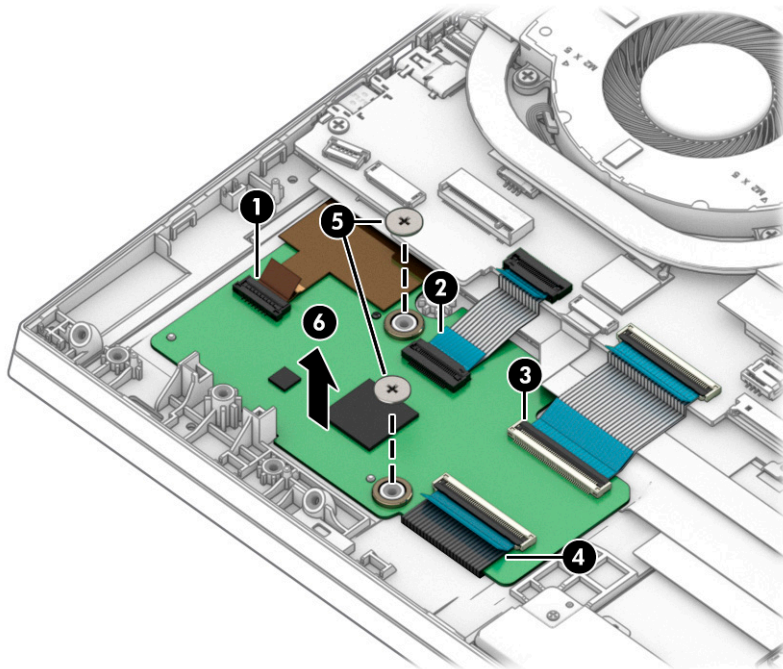

Reverse this procedure to install the RGB keyboard control board.

Power connector cable

To remove the power connector cable, use this procedure and illustration.

Table 6-3 Power connector cable description and part number

Description	Spare part number
Power connector cable	L98734-001

Before removing the power connector cable, follow these steps:

1. Prepare the computer for disassembly ([Preparation for disassembly on page 31](#)).
2. Remove the bottom cover ([Bottom cover on page 31](#)).

3. Remove the solid-state drive to the left of the battery ([Solid-state drive on page 32](#)).
4. Remove the battery (see [Battery on page 37](#)).

Remove the power connector cable:

1. Disconnect the cable from the system board (1), and then remove the cable from the routing along the fan (2).
2. Remove the Phillips M2.0 × 5.0 screw (3) that secures the power connector cable to the computer.
3. Remove the bracket from the power connector (4), and then remove the power connector cable from the computer (5).

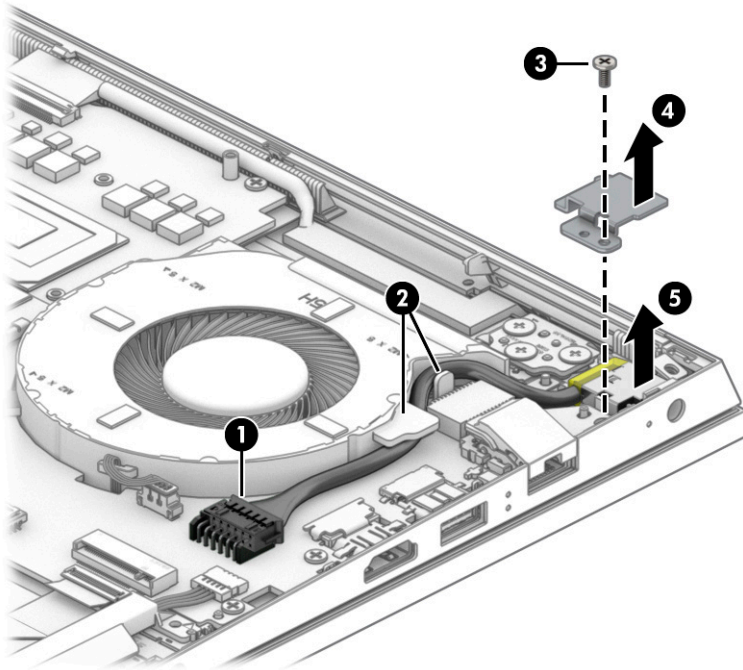

Reverse this procedure to install the power connector cable.

Speakers

To remove the speakers, use this procedure and illustration.

Table 6-4 Speaker description and part number

Description	Spare part number
Speaker Kit	L98748-001

Before removing the speakers, follow these steps:

1. Prepare the computer for disassembly ([Preparation for disassembly on page 31](#)).
2. Remove the bottom cover ([Bottom cover on page 31](#)).
3. Remove the solid-state drives ([Solid-state drive on page 32](#)).
4. Remove the battery (see [Battery on page 37](#)).

Remove the speakers:

1. Disconnect the cables for each speaker from the system board (1).
2. Remove the two Phillips M2.0 × 4.0 screws from each speaker (2).
3. Remove the speakers from the computer (3).

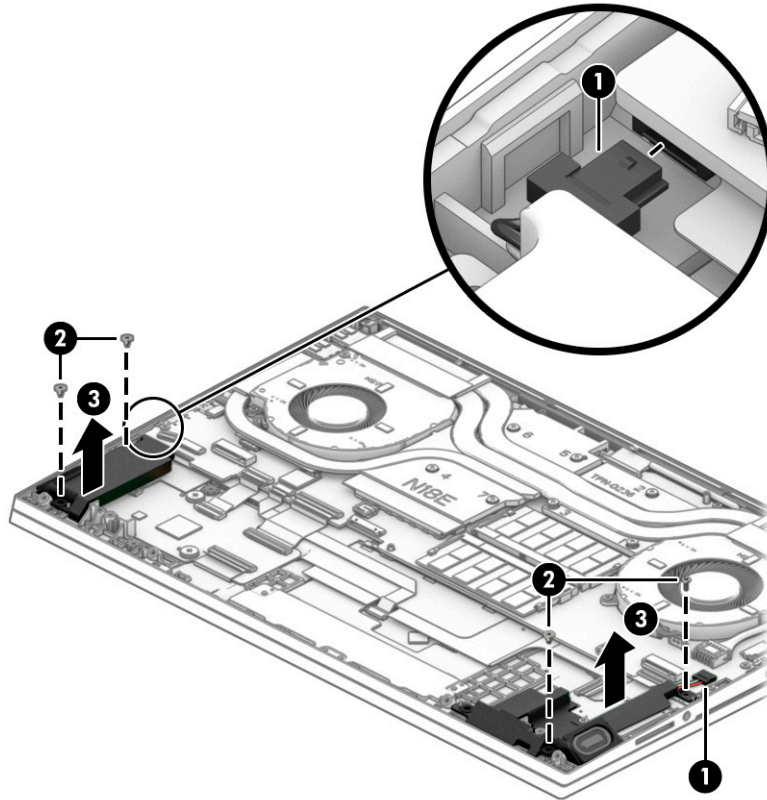

Reverse this procedure to install the speakers.

Card reader/audio board

To remove the card reader/audio board, use this procedure and illustration.

Table 6-5 Card reader/audio board description and part number

Description	Spare part number
Card reader/audio board	L98744-001
Card reader/audio board cable	L98727-001

Before removing the card reader/audio board, follow these steps:

1. Prepare the computer for disassembly ([Preparation for disassembly on page 31](#)).
2. Remove the bottom cover ([Bottom cover on page 31](#)).
3. Remove the solid-state drives ([Solid-state drive on page 32](#)).
4. Remove the battery (see [Battery on page 37](#)).
5. Remove the left speaker (see [Speakers on page 40](#)).

Remove the card reader/audio board:

1. Disconnect the cable from the ZIF connector on the board (1).
2. Remove the Phillips M2.0 × 5.0 screw (2) that secures the board to the computer.
3. Lift the inside of the board upward (3), and then remove the board from the computer (4).

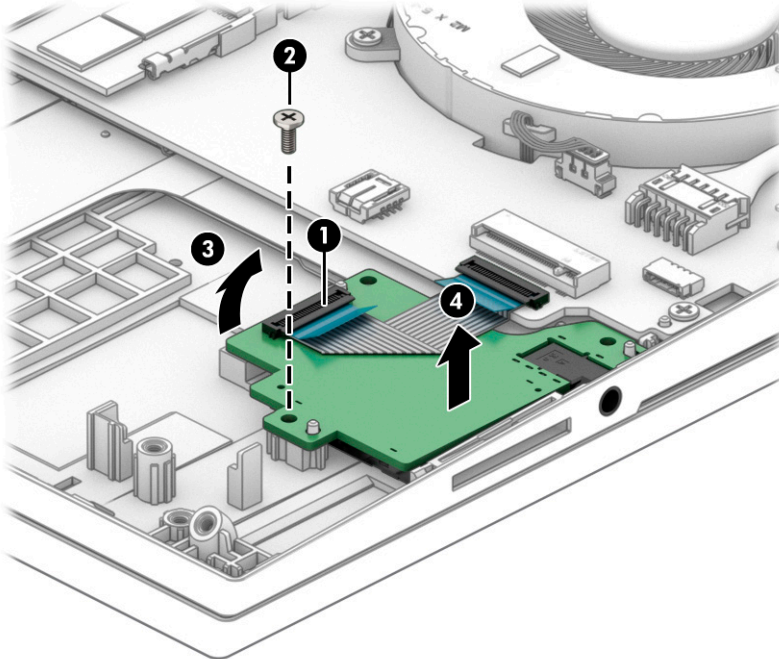

Reverse this procedure to install the card reader/audio board.

Heat sink

To remove the heat sink, use these procedures and illustrations.

Table 6-6 Heat sink descriptions and part numbers

Description	Spare part number
Heat sink for use in models with GeForce GTX 1660, 1660Ti, and RTX graphics cards	L98735-001
Heat sink for use in models with GeForce GTX 1650, 1650Ti graphics cards	L98736-001
Heat sink thermal pad kit for use in models with GeForce GTX 1660, 1660Ti, and RTX graphics cards	L98955-001
Heat sink thermal pad kit for use in models with GeForce GTX 1650, 1650Ti graphics cards	M00753-001

Before removing the heat sink, follow these steps:

1. Prepare the computer for disassembly ([Preparation for disassembly on page 31](#)).
2. Remove the bottom cover ([Bottom cover on page 31](#)).
3. Remove the solid-state drives ([Solid-state drive on page 32](#)).
4. Remove the battery (see [Battery on page 37](#)).

Remove the heat sink:

1. Remove the two Phillips M2.0 × 5.0 screws (1) that secure the heat sink to the computer.
2. Loosen the seven captive Phillips screws (2) that secure the heat sink to the computer.
3. Remove the heat sink from the computer (3).

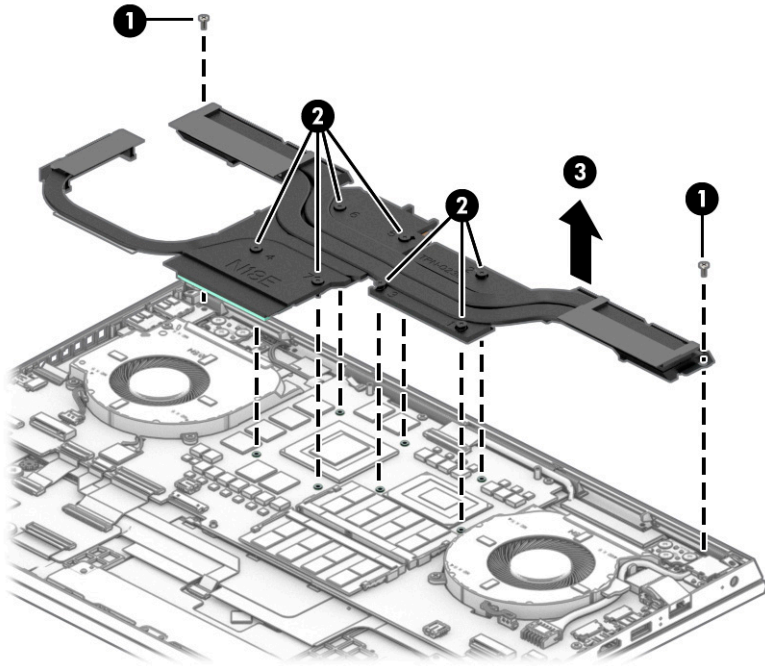

4. (GeForce GTX 1660, 1660Ti, and RTX graphics cards) Thoroughly clean the thermal material from the surfaces of the heat sink and the system board components each time the heat sink is removed. Replacement thermal material is included with the heat sink and system board spare part kits. The following illustration shows the replacement thermal material locations.

Thermal paste is used on the system board components **(1), (3), (5)** and on the heat sink areas **(2), (4), (6)** that service them.

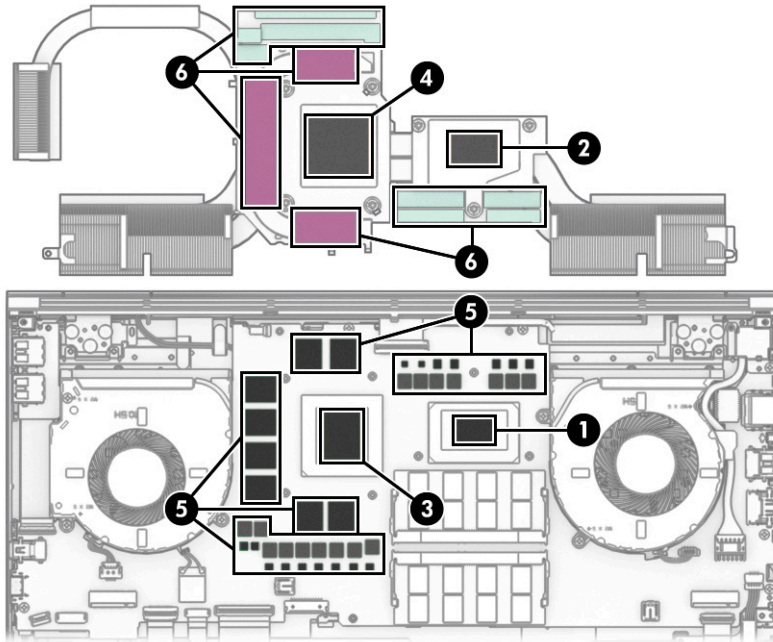

5. (GeForce GTX 1650, 1650Ti graphics cards) Thoroughly clean the thermal material from the surfaces of the heat sink and the system board components each time the heat sink is removed. Replacement thermal material is included with the heat sink and system board spare part kits. The following illustration shows the replacement thermal material locations.

Thermal paste is used on the system board components **(1), (3), (5)** and on the heat sink areas **(2), (4), (6)** that service them.

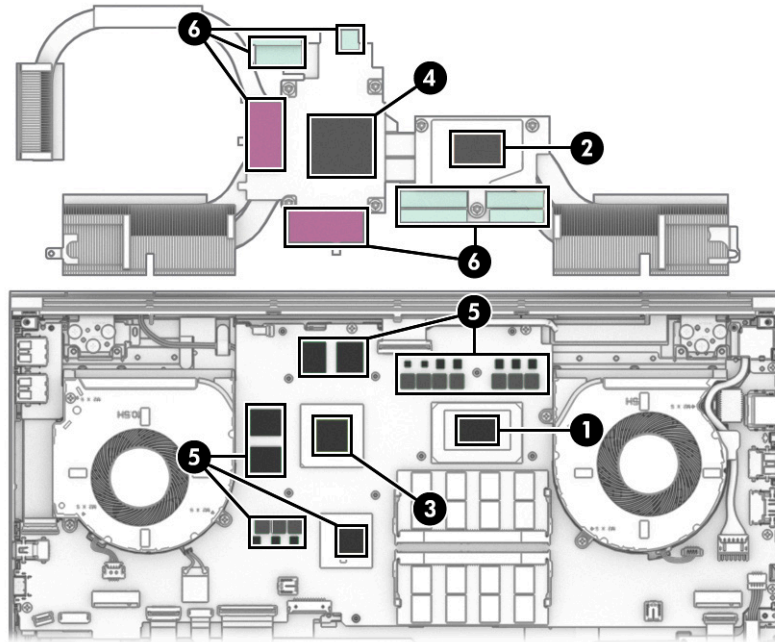

Reverse this procedure to install the heat sink.

Fans

To remove the fans, use this procedure and illustration.

Table 6-7 Fan description and part number

Description	Spare part number
Fan assembly for use in models with GeForce GTX 1660, 1660Ti, and RTX graphics cards	L98737-001
Fan assembly for use in models with GeForce GTX 1650, 1650Ti graphics cards	L98738-001

Before removing the fans, follow these steps:

1. Prepare the computer for disassembly ([Preparation for disassembly on page 31](#)).
2. Remove the bottom cover ([Bottom cover on page 31](#)).
3. Remove the solid-state drives ([Solid-state drive on page 32](#)).
4. Remove the battery (see [Battery on page 37](#)).
5. Remove the heat sink (see [Heat sink on page 42](#)).

Remove the fans:



NOTE: Use the same steps to remove each fan.

1. Disconnect the fan cable from the system board (1).
2. Remove the three Phillips M2.0 × 5.0 screws (2) that secure the fan to the computer.
3. Remove the fan from the computer (3).

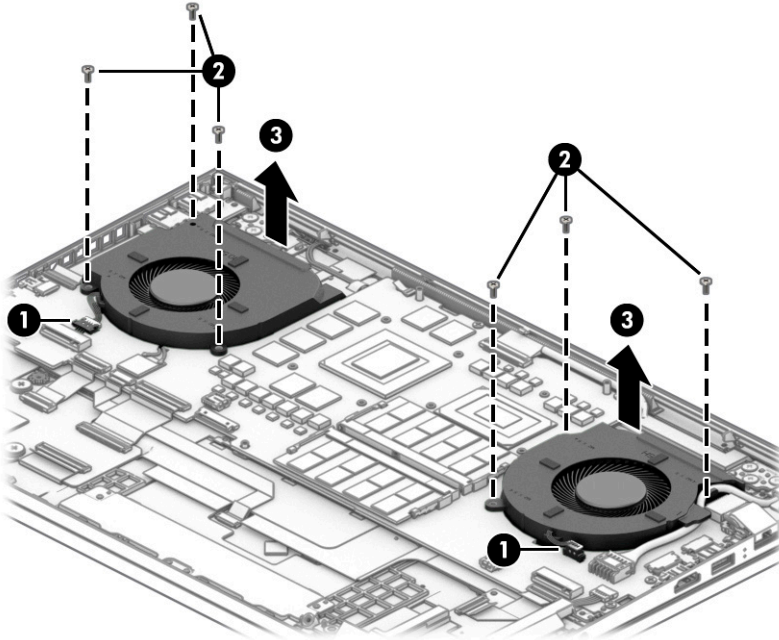

Reverse this procedure to install the fans.

USB board

To remove the USB board, use this procedure and illustration.

Table 6-8 USB board description and part number

Description	Spare part number
USB board	L98742-001
USB board cable	L98725-001

Before removing the USB board, follow these steps:

1. Prepare the computer for disassembly ([Preparation for disassembly on page 31](#)).
2. Remove the bottom cover ([Bottom cover on page 31](#)).
3. Remove the solid-state drives ([Solid-state drive on page 32](#)).
4. Remove the battery (see [Battery on page 37](#)).
5. Remove the heat sink (see [Heat sink on page 42](#)).
6. Remove the right fan (see [Fans on page 45](#)).

Remove the USB board:

1. Disconnect the cable from the system board ZIF connector (1).
2. Lift the cable to release it from the computer (2).
3. Remove the board from the computer (3).

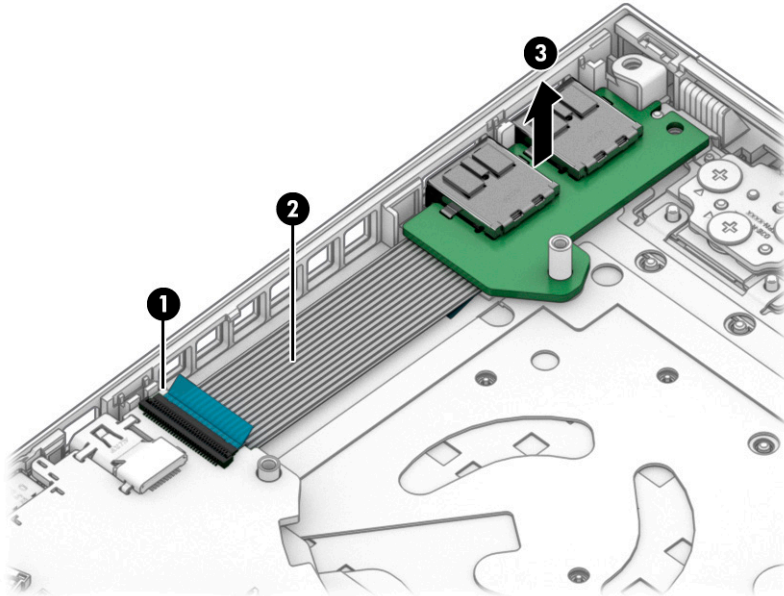

Reverse this procedure to install the USB board.

RJ-45 door

To remove the RJ-45 door, use this procedure and illustration.

Table 6-9 RJ-45 door description and part number

Description	Spare part number
RJ-45 door for use in models with GeForce GTX 1660, 1660Ti, and RTX graphics cards	L98959-001
RJ-45 door for use in models with GeForce GTX 1650, 1650Ti graphics cards	L99533-001

Before removing the RJ-45 door, follow these steps:

1. Prepare the computer for disassembly ([Preparation for disassembly on page 31](#)).
2. Remove the bottom cover ([Bottom cover on page 31](#)).

Remove the RJ-45 door:

1. Use a flat tool to push the tab on the inside-bottom of the door toward the outside of the system board to release it (1).

2. Remove the door (2).

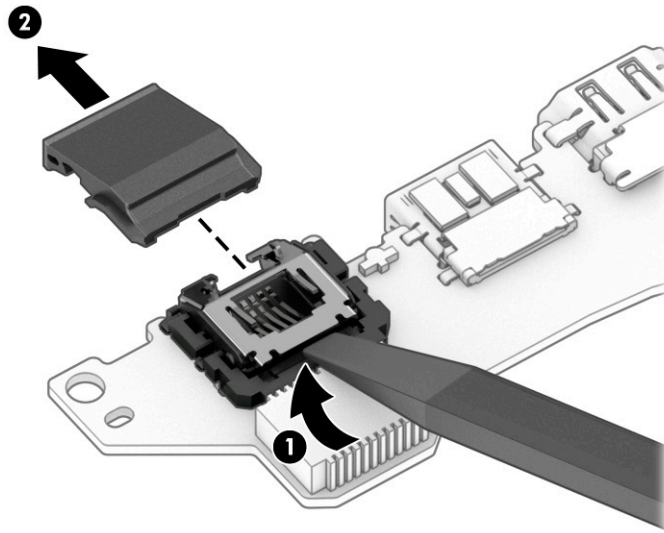

Reverse this procedure to install the RJ-45 door.

System board

To remove the system board, use these procedures and illustrations.

Table 6-10 System board descriptions and part numbers

Description	Spare part number
System board (includes processor):	
All system boards use the following part numbers:	
xxxxxx-001: Non-Windows operating system	
xxxxxx-601: Windows 10 operating system	
System board with integrated Intel Core i7-10750H processor and GeForce RTX 2070S, 8 GB graphics card	L98756-xx1
System board with integrated Intel Core i7-10750H processor and GeForce RTX 2070S, 8 GB graphics card and an OLED display	L98758-xx1
System board with integrated Intel Core i7-10750H processor and GeForce RTX 2070, 8 GB graphics card	L98755-xx1
System board with integrated Intel Core i7-10750H processor and GeForce RTX 2070, 8 GB graphics card and an OLED display	M05057-xx1
System board with integrated Intel Core i7-10750H processor and GeForce RTX 2060, 6 GB graphics card	M00123-xx1
System board with integrated Intel Core i7-10750H processor and GeForce RTX 2060, 6 GB graphics card and an OLED display	M00124-xx1
System board with integrated Intel Core i7-10750H processor and GeForce GTX 1660Ti, 6 GB graphics card	L98750-xx1
System board with integrated Intel Core i7-10750H processor and GeForce GTX 1650Ti, 4 GB graphics card	L98753-xx1
System board with integrated Intel Core i5-10300H processor and GeForce RTX 2070, 8 GB graphics card	L98754-xx1
System board with integrated Intel Core i5-10300H processor and GeForce RTX 2060, 6 GB graphics card	M00122-xx1

Table 6-10 System board descriptions and part numbers (continued)

Description	Spare part number
System board with integrated Intel Core i5-10300H processor and GeForce GTX 1660Ti, 6 GB graphics card	L98749-xx1
System board with integrated Intel Core i5-10300H processor and GeForce GTX 1650Ti, 4 GB graphics card	L98752-xx1
System board with integrated Intel Core i5-10300H processor and GeForce GTX 1650, 4 GB graphics card	L98751-xx1

Before removing the system board, follow these steps:

1. Prepare the computer for disassembly ([Preparation for disassembly on page 31](#)).
2. Remove the bottom cover ([Bottom cover on page 31](#)).
3. Remove the solid-state drive to the left of the battery ([Solid-state drive on page 32](#)).
4. Remove the battery (see [Battery on page 37](#)).
5. Remove the fans (see [Fans on page 45](#)).

When you replace the system board, be sure to remove the following components (as applicable) from the defective system board and install them on the replacement system board:

- Memory modules (see [Memory modules on page 34](#)).
- Solid-state drives (see [Solid-state drive on page 32](#)).
- Heat sink (see [Heat sink on page 42](#)).

Remove the system board:

1. Disconnect the following connectors from the system board:
 - IR cable (ZIF) **(1)**
 - Display cable **(2)**
 - Power connector cable **(3)**
 - Left speaker cable **(4)**
 - Card reader/audio board cable (ZIF) **(5)**
 - RGB board cable (ZIF) **(6)**
 - WLAN antennas from integrated WLAN module **(7)**
 - Touchpad cable (ZIF) **(8)**
 - RGB board cable (ZIF) **(9)**
 - Right speaker cable **(10)**
 - USB board cable (ZIF) **(11)**

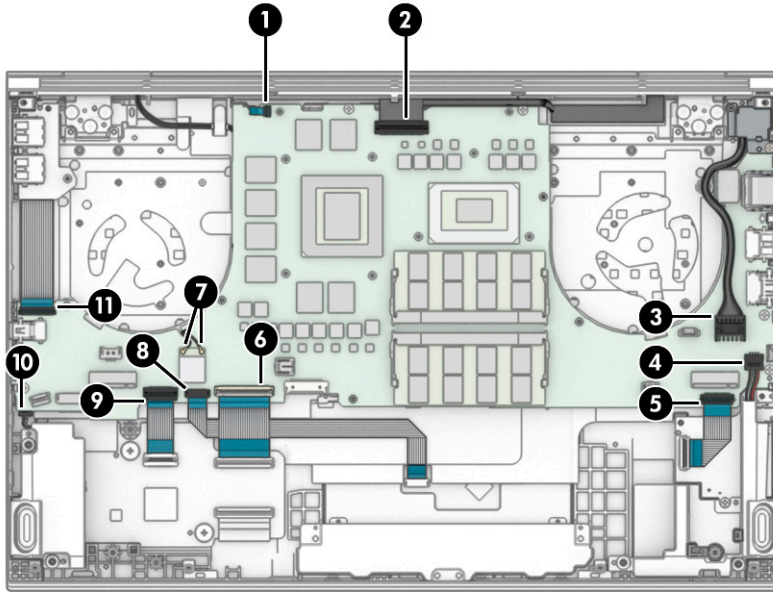

2. Remove five Phillips M2.0 × 5.0 screws **(1)** that secure the system board to the computer.
3. Remove the system board **(2)**.

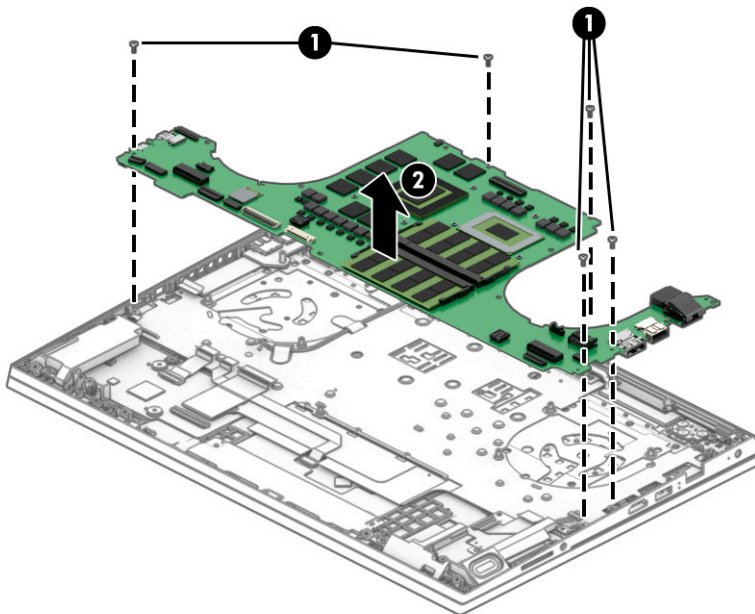

Reverse this procedure to install the system board.

Infrared (IR) board

To remove the IR board, use this procedure and illustration.

Table 6-11 IR board description and part number

Description	Spare part number
IR board	L98743-001
IR board cable	L98726-001

Before removing the IR board, follow these steps:

1. Prepare the computer for disassembly ([Preparation for disassembly on page 31](#)).
2. Remove the bottom cover ([Bottom cover on page 31](#)).
3. Remove the solid-state drives ([Solid-state drive on page 32](#)).
4. Remove the battery (see [Battery on page 37](#)).
5. Remove the fans (see [Fans on page 45](#)).
6. Remove the system board (see [System board on page 48](#)).

Remove the IR board:

1. Remove the Phillips M2.0 × 3.0 screw (1) that secures the IR board to the computer.
2. Remove the IR board from the computer (2).

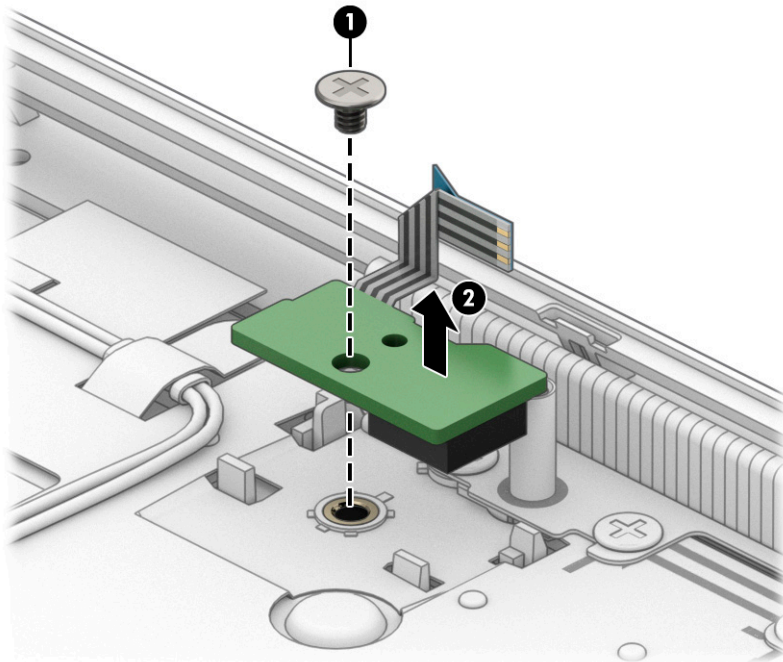

Reverse this procedure to install the IR board.

Touchpad

To remove the touchpad, use this procedure and illustration.

Table 6-12 Touchpad description and part number

Description	Spare part number
Touchpad	L98745-001
Touchpad cable	L98730-001

Before removing the touchpad, follow these steps:

1. Prepare the computer for disassembly ([Preparation for disassembly on page 31](#)).
2. Remove the bottom cover ([Bottom cover on page 31](#)).
3. Remove the solid-state drives ([Solid-state drive on page 32](#)).
4. Remove the battery (see [Battery on page 37](#)).

Remove the touchpad:

1. Remove the four Phillips M1.6 × 2.3 screws **(1)** that secure the touchpad bracket to the computer.
2. Remove the bracket from the computer **(2)**.

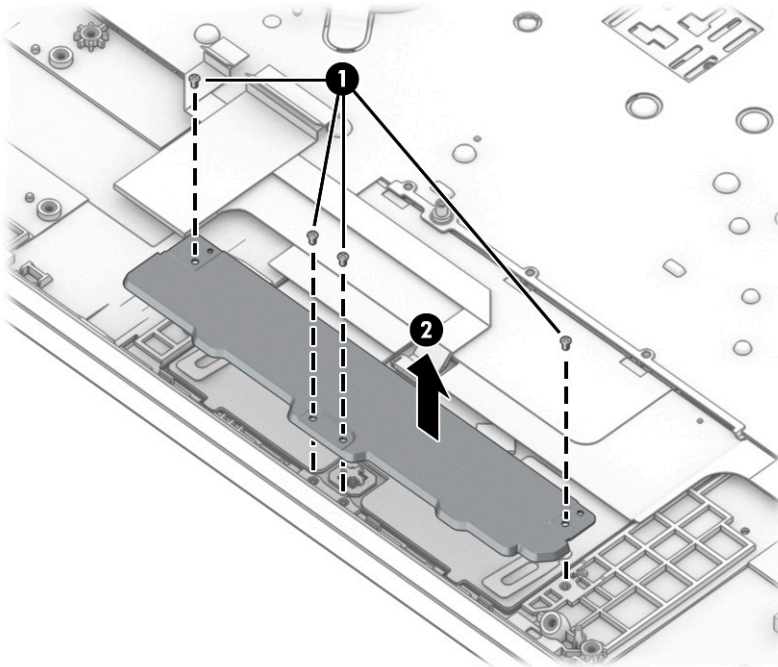

3. Disconnect the cable from the ZIF connector on the touchpad **(1)**.
4. Lift the protective tape from the top of the touchpad **(2)** and the tape from over the right screw **(3)**.
5. Remove the three Phillips M2.0 × 2.0 screws **(4)** that secure the touchpad to the computer.

6. Remove the touchpad from the computer (5).

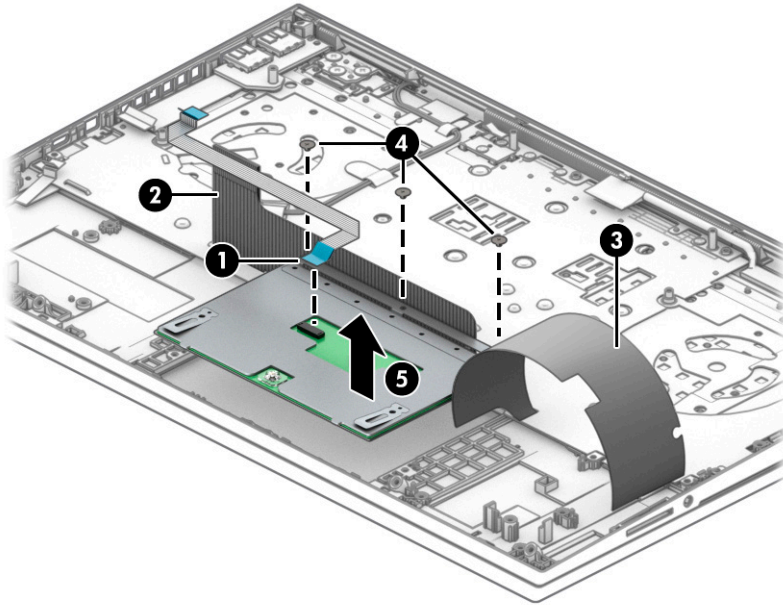

Reverse this procedure to install the touchpad.

When replacing the touchpad, make sure the protective tape is correctly layered on top of the touchpad. Use the following image to determine proper tape placement.

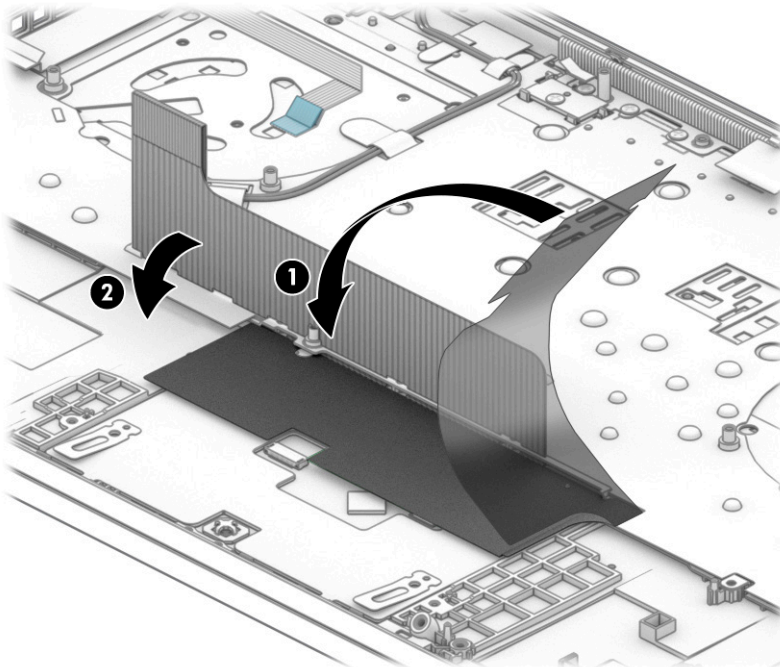

Display assembly

To remove and disassemble the display assembly, use these procedures and illustrations.

Before removing the display panel, follow these steps:

1. Prepare the computer for disassembly ([Preparation for disassembly on page 31](#)).
2. Remove the bottom cover ([Bottom cover on page 31](#)).
3. Remove the solid-state drives ([Solid-state drive on page 32](#)).
4. Remove the battery (see [Battery on page 37](#)).
5. Remove the fans (see [Fans on page 45](#)).
6. Remove the system board (see [System board on page 48](#)).

Remove the display assembly:

1. Lift the three pieces of tape that secure the antenna cables (**1**).
2. Remove the antenna cables from their routing path in the computer (**2**).

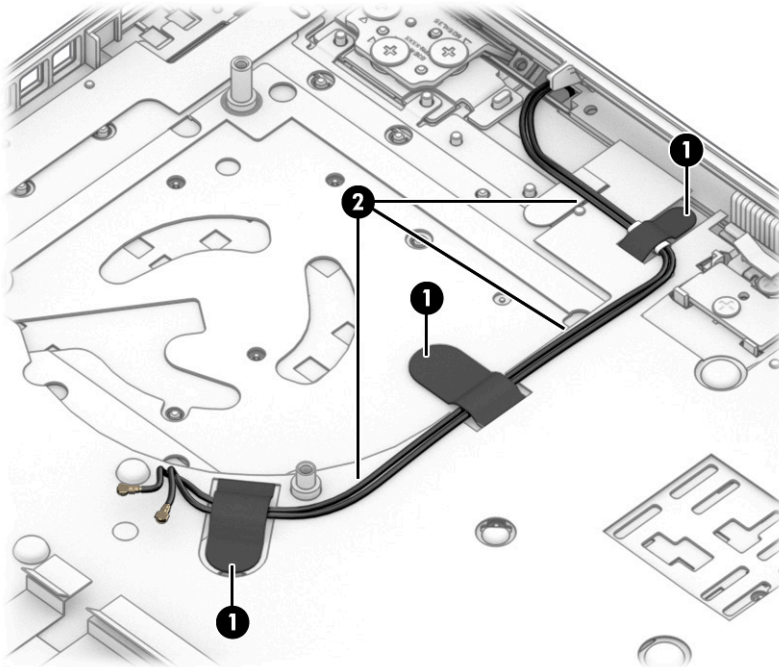

3. Remove the six Phillips M2.5 × 3.5 screws (**1**) that secure the display to the computer.

4. Open the computer until the display is at approximately 45° (2), and then close the computer (3). This step opens the hinges.

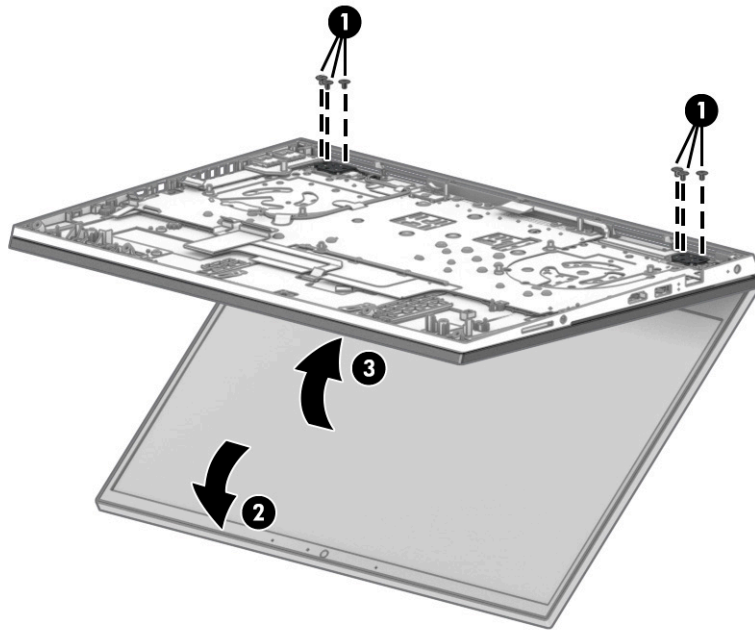

5. While pulling the display cable (1) and WLAN antenna cables (1) through the holes in the computer, pull display away from computer (2).

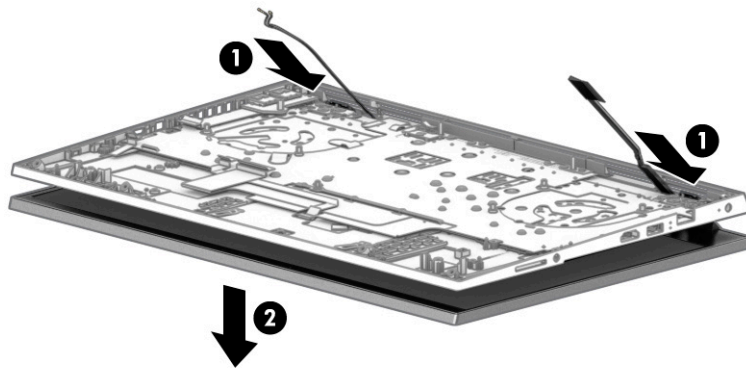

6. If you need to replace display assembly subcomponents:
 - a. Flex the top (1) and the inside edges of the left and right sides of the bezel (2) to release it.
 - b. Slide a flat tool (3) across the inside of the bottom of the bezel to release it (4), and then remove the bezel from the display (5).

The bezel is available as spare part number L99532-001. Bezel adhesive is available as spare part number L98957-001.

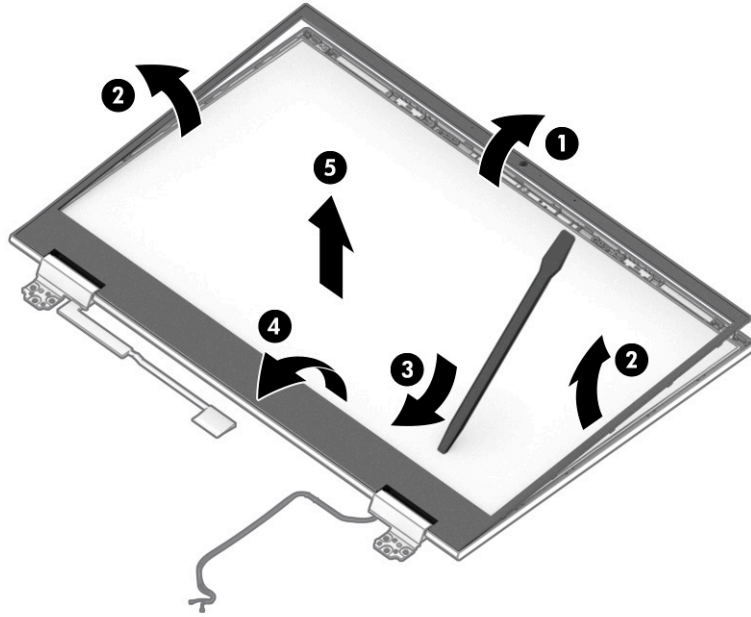

7. If you need to remove the hinges from the display enclosure:
- a. Remove the three Phillips broadhead M2.0 × 2.0 screws (1) and the two Phillips M2.0 × 2.0 screws (2) from each hinge.
 - b. Remove the hinges from the display (3).

The display hinges are available as spare part number L98740-001.

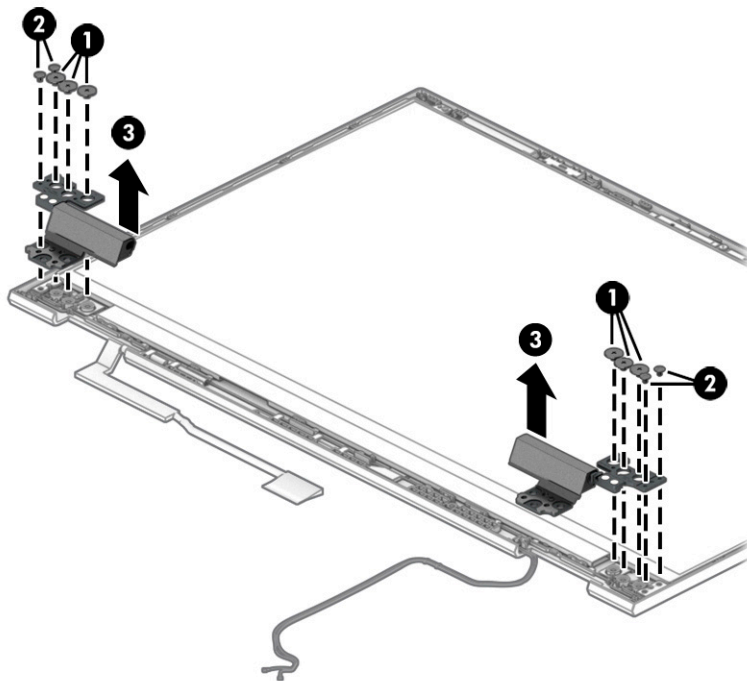

8. If you need to remove the hinge covers from the hinges, remove the two Phillips M1.6 × 2.3 screws **(1)** from each hinge cover, and then pull the hinge covers off the hinges **(2)**.

The hinge covers are available as spare part number L98741-001.

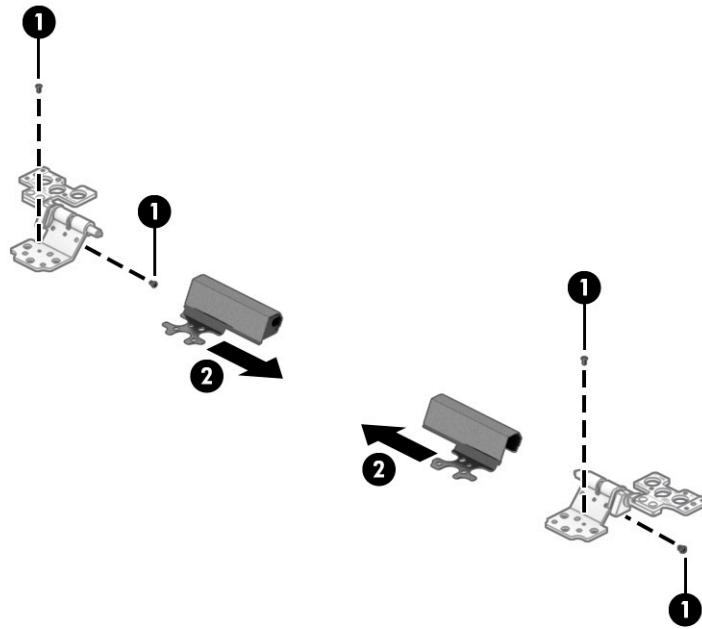

9. If you need to remove the display panel:

- a. The display panel is secured to the display enclosure with tape that is installed under the left and right sides of the panel. To remove the panel, use tweezers to grasp the end of the tape **(1)**. While turning the tweezers, wrap the tape around the tweezers **(2)** as you continue to pull the tape out from behind the display panel **(3)**. You must pull the tape multiple times before it is completely removed.

- b.** Rotate the display panel over and place it next to the display enclosure **(4)**.

Display panels are available as the following spare part numbers:

L99597-001: FHD, 250 nits

L99598-001: FHD, 300 nits

L99600-001: FHD, 144 Hz

M12468-001: FHD, 144 Hz, flat

L99601-001: FHD, 300 Hz

L99602-001: UHD, 120 Hz

M01025-001: UHD, OLED

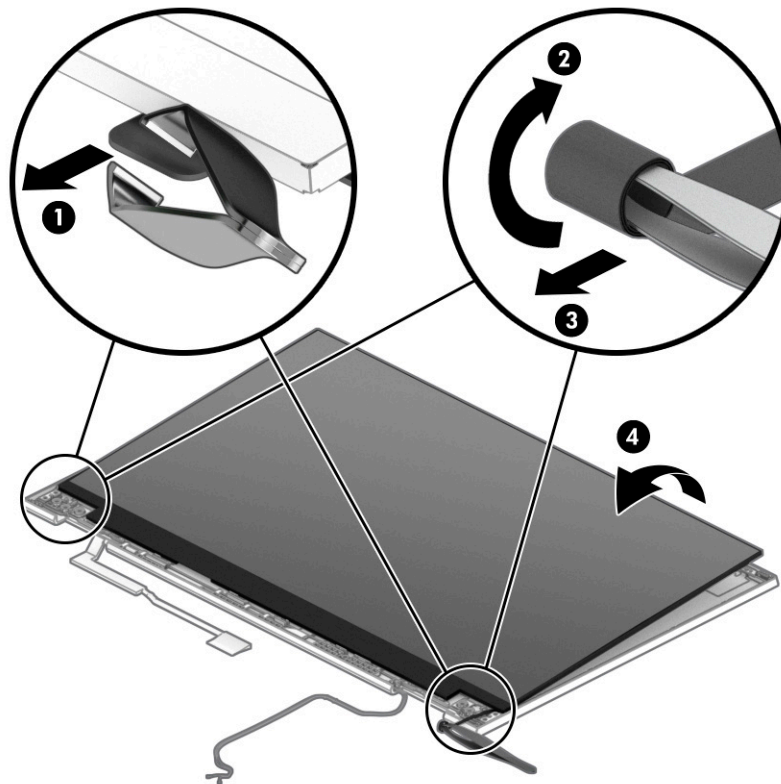

- c.** Lift the tape from the connector on the display panel **(1)**, and then disconnect the cable from the panel **(2)**.

- d.** Remove the panel **(3)**.

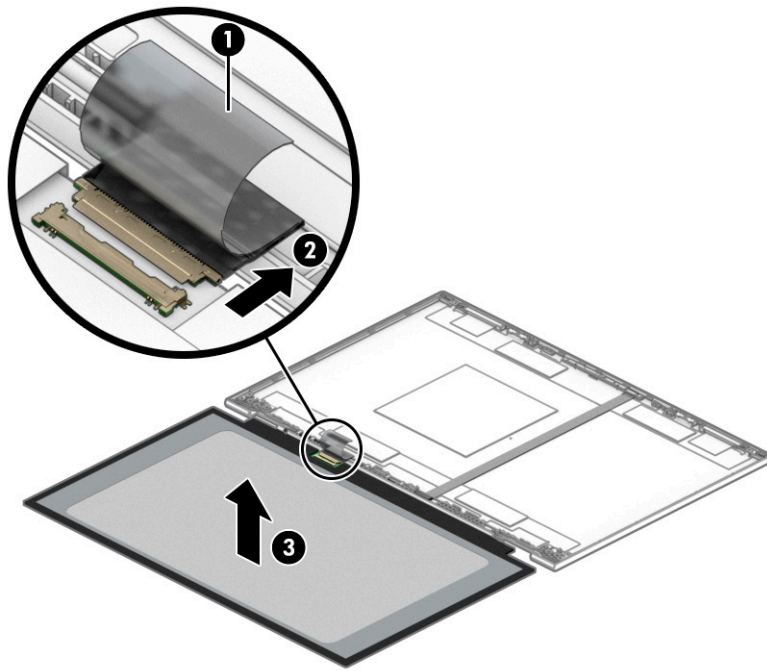

10. If you need to remove the camera module:

- a. Lift up evenly across the module and peel the module up from the display back cover **(1)**, and then disconnect the cable from the reverse ZIF connector on the module **(2)**. The camera module is available as spare part number L98760-001.

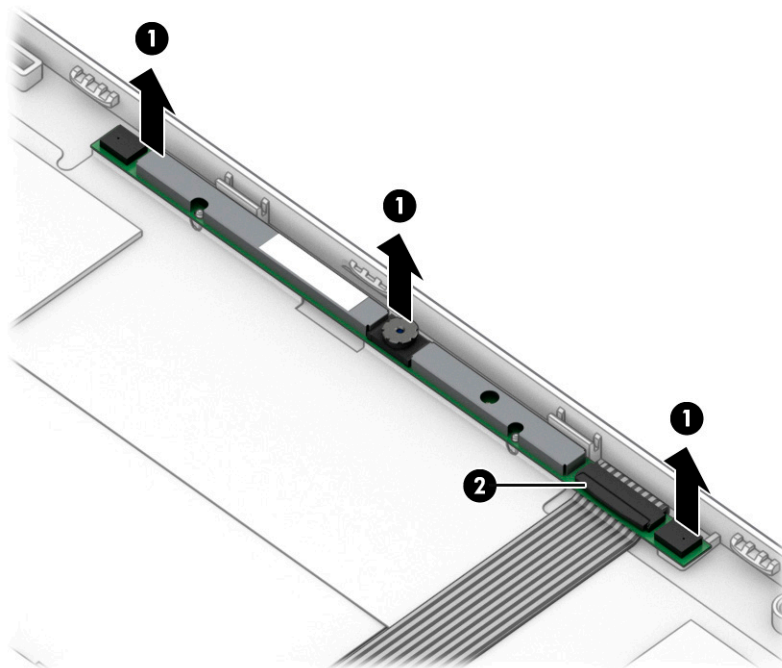

- b. When installing a camera module, before connecting the cable **(1)**, be sure to route the cable under the module **(2)**, and then press the module evenly into place **(3)**.

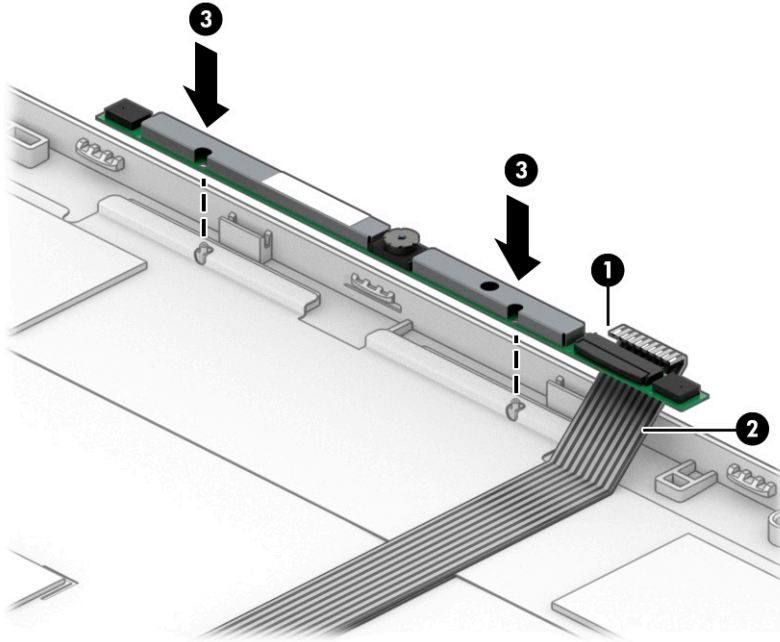

11. If you need to remove the hinge brackets, remove the Phillips M2.0 × 3.0 screw (1) from each bracket, and then remove the brackets from the display back cover (2).

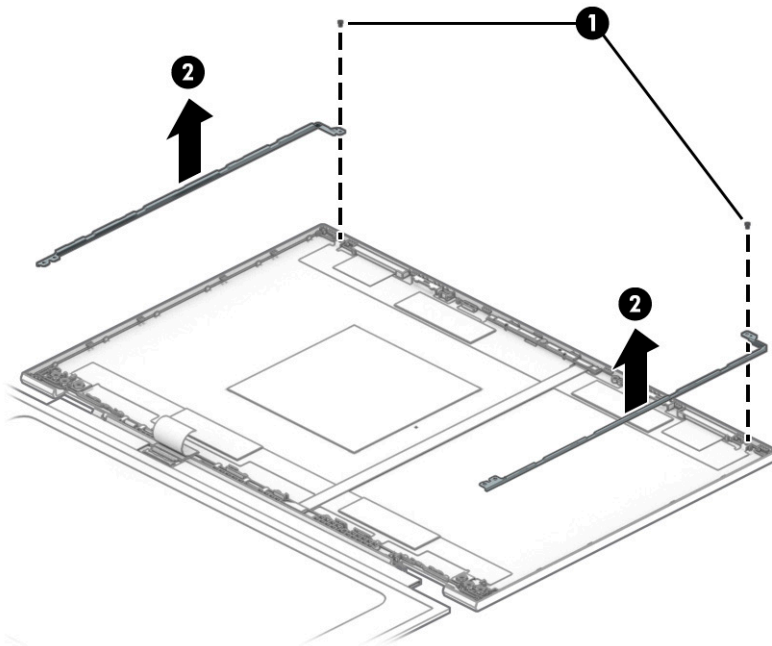

- 12.** If you need to remove the display/camera cable, peel the cable off the inside of the display back cover **(1)**, remove the cable from the clips at the bottom of the cover **(2)**, and then remove the cable **(3)**.

Display panels cable are available as the following spare part numbers:

L98732-001: UHD 120 Hz/144 Hz display panels

L98733-001: FHD display panels

M01024-001: OLED display panels

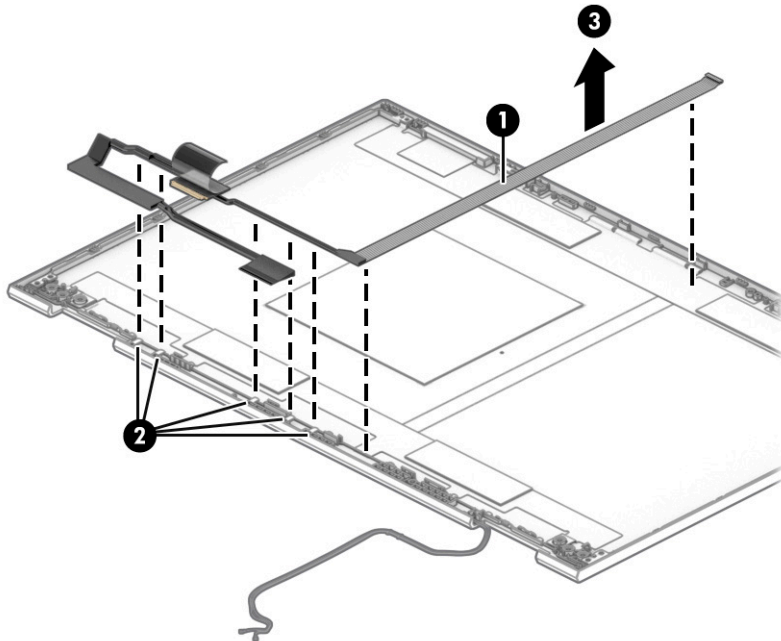

13. If you need to remove the antenna cables, peel the antennas off the inside of the display back cover (1), remove the cables from the clips at the bottom of the back cover (2), and then remove the antennas and cables (3).

Antenna cables are available as spare part number L98720-001.

Display back covers are available as spare part numbers:

L98721-001: For use in models with 2.6 mm displays

L98722-001: For use in models with 3.2 mm displays

M01023-001: For use in models with OLED displays

Display back cover adhesive is available as spare part number L98958-001.

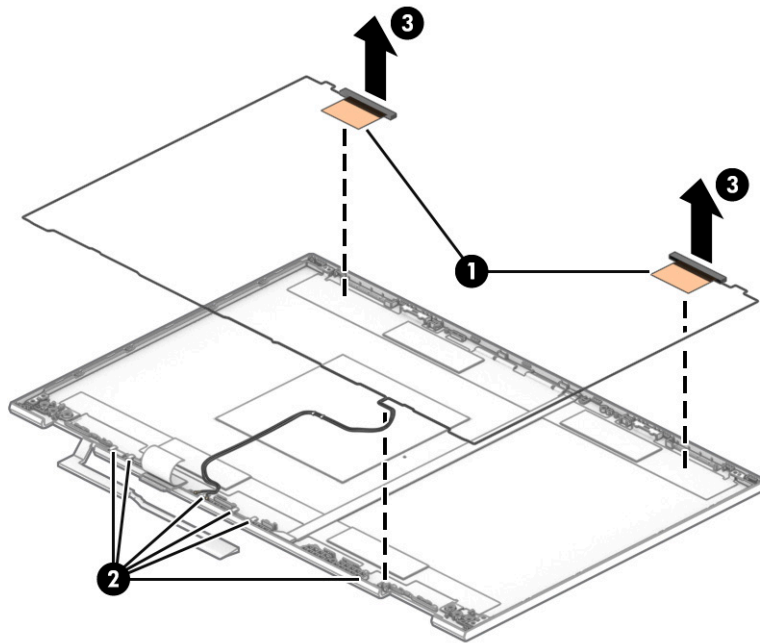

Reverse this procedure to reassemble and replace the display assembly.

Keyboard with top cover

The top cover with keyboard remains after removing all other spare parts from the computer. In this section, the first table provides the main spare part number for the top cover/keyboards. The second table provides the country codes.

Table 6-13 Keyboard descriptions and part numbers

Description	Spare part number
Models without a Thunderbolt connector:	
Keyboard with top cover, dragon red legend keyboard, 1-zone lighting	L98943-001
Keyboard with top cover, white legend keyboard, RGB 4-zone lighting	L98944-001
Keyboard with top cover, white legend keyboard, RGB, per key lighting	L98945-001
Keyboard with top cover, dragon red legend keyboard, 1-zone lighting, with numeric keypad	L98946-001
Keyboard with top cover, white legend keyboard, RGB 4-zone lighting, with numeric keypad	L98947-001

Table 6-13 Keyboard descriptions and part numbers (continued)

Description	Spare part number
Models with a Thunderbolt connector:	
Keyboard with top cover, dragon red legend keyboard, 1-zone lighting	M00838-001
Keyboard with top cover, white legend keyboard, RGB per key lighting	M00839-001
Keyboard with top cover, white legend keyboard, RGB, 4-zone lighting	M00840-001
Keyboard with top cover, dragon red legend keyboard, 1-zone lighting, with numeric keypad	M00841-001
Keyboard with top cover, white legend keyboard, RGB 4-zone lighting, with numeric keypad	M00842-001

Table 6-14 Spare part country codes

For use in country or region	Spare part number	For use in country or region	Spare part number	For use in country or region	Spare part number
Belgium	-A41	Iceland	-DD1	Slovenia	-BA1
Brazil	-201	India	-D61	South Korea	-AD1
Bulgaria	-261	Israel	-BB1	Spain	-071
Chile	-161	Italy	-061	Switzerland	-BG1
Czech Republic/Slovakia	-FL1	Japan	-291	Taiwan	-AB1
Denmark, Finland, and Norway	-DH1	The Netherlands	-B31	Thailand	-281
French Canada	-DB1	Northern Africa	-FP1	Turkey	-141
France	-051	Portugal	-131	Ukraine	-BD1
Germany	-041	Romania	-271	United Kingdom	-031
Greece	-151	Russia	-251	United States	-001
Hungary	-211	Saudi Arabia	-171		

7 Using Setup Utility (BIOS)

Setup Utility, or Basic Input/Output System (BIOS), controls communication between all the input and output devices on the system (such as disk drives, display, keyboard, mouse, and printer). Setup Utility (BIOS) includes settings for the types of devices installed, the startup sequence of the computer, and the amount of system and extended memory.

 **NOTE:** To start Setup Utility on convertible computers, your computer must be in notebook mode and you must use the keyboard attached to your notebook.

Starting Setup Utility (BIOS)

You have several ways to access the Setup Utility (BIOS).

 **IMPORTANT:** Use extreme care when making changes in Setup Utility (BIOS). Errors can prevent the computer from operating properly.

▲ Turn on or restart the computer and quickly press **f10**.

– or –

Turn on or restart the computer, quickly press **esc**, and then press **f10** when the Start menu is displayed.

Updating Setup Utility (BIOS)

Updated versions of Setup Utility (BIOS) might be available on the HP website. Most BIOS updates on the HP website are packaged in compressed files called *SoftPaqs*. Some download packages contain a file named *Readme.txt*, which contains information regarding installing and troubleshooting the file.

Determining the BIOS version

To decide whether you need to update Setup Utility (BIOS), first determine the BIOS version on your computer.

To reveal the BIOS version information (also known as *ROM date* and *System BIOS*), use one of these options.

- HP Support Assistant
 1. Type `support` in the taskbar search box, and then select the **HP Support Assistant** app.
 - or –
 - Select the question mark icon in the taskbar.
 2. Select **My notebook**, and then select **Specifications**.
- Setup Utility (BIOS)
 1. Start Setup Utility (BIOS) (see [Starting Setup Utility \(BIOS\) on page 65](#)).
 2. Select **Main**, and then make note of the BIOS version.
 3. Select **Exit**, select one of the options, and then follow the on-screen instructions.
- In Windows, press `ctrl+alt+s`.

To check for later BIOS versions, see [Preparing for a BIOS update on page 66](#).

Preparing for a BIOS update

Be sure to follow all prerequisites before downloading and installing a BIOS update.

 **IMPORTANT:** To reduce the risk of damage to the computer or an unsuccessful installation, download and install a BIOS update only when the computer is connected to reliable external power using the AC adapter. Do not download or install a BIOS update while the computer is running on battery power, docked in an optional docking device, or connected to an optional power source. During the download and installation, follow these instructions:

- Do not disconnect power from the computer by unplugging the power cord from the AC outlet.
- Do not shut down the computer or initiate Sleep.
- Do not insert, remove, connect, or disconnect any device, cable, or cord.

 **NOTE:** If your computer is connected to a network, consult the network administrator before installing any software updates, especially system BIOS updates.

Downloading a BIOS update

After you review the prerequisites, you can check for and download BIOS updates.

1. Type `support` in the taskbar search box, and then select the **HP Support Assistant** app.
– or –
Select the question mark icon in the taskbar.
2. Select **Updates**, and then select **Check for updates and messages**.
3. Follow the on-screen instructions.
4. At the download area, follow these steps:
 - a. Identify the most recent BIOS update and compare it to the BIOS version currently installed on your computer. If the update is more recent than your BIOS version, make a note of the date, name, or other identifier. You might need this information to locate the update later, after it has been downloaded to your hard drive.
 - b. Follow the on-screen instructions to download your selection to the hard drive.
Make a note of the path to the location on your hard drive where the BIOS update is downloaded. You will need to access this path when you are ready to install the update.

Installing a BIOS update

BIOS installation procedures vary. Follow any instructions that appear on the screen after the download is complete. If no instructions appear, follow these steps.

1. Type `file` in the taskbar search box, and then select **File Explorer**.
2. Select your hard drive designation. The hard drive designation is typically Local Disk (C:).
3. Using the hard drive path you recorded earlier, open the folder that contains the update.
4. Double-click the file that has an `.exe` extension (for example, `filename.exe`).
The BIOS installation begins.
5. Complete the installation by following the on-screen instructions.



NOTE: After a message on the screen reports a successful installation, you can delete the downloaded file from your hard drive.

8 Backing up, restoring, and recovering

This chapter provides information about processes that are standard procedure for most products.

- **Backing up your personal information**—You can use Windows tools to back up your personal information (see [Using Windows tools on page 69](#)).
- **Creating a restore point**—You can use Windows tools to create a restore point (see [Using Windows tools on page 69](#)).
- **Creating recovery media** (select products only)—You can use the HP Cloud Recovery Download Tool (select products only) to create recovery media (see [Using the HP Cloud Recovery Download Tool to create recovery media \(select products only\) on page 69](#)).
- **Restoring and recovery**—Windows offers several options for restoring from backup, refreshing the computer, and resetting the computer to its original state (see [Using Windows tools on page 69](#)).

 **IMPORTANT:** If you will be performing recovery procedures on a tablet, the tablet battery must be at least 70% charged before you start the recovery process.

IMPORTANT: For a tablet with a detachable keyboard, connect the tablet to the keyboard base before beginning any recovery process.

Backing up information and creating recovery media

These methods of creating recovery media and backups are available on select products only. Choose the appropriate method for your computer model.

Using Windows tools

You can use Windows tools to back up personal information and create system restore points and recovery media.

 **IMPORTANT:** Windows is the only option that allows you to back up your personal information. Schedule regular backups to avoid information loss.

 **NOTE:** If computer storage is 32 GB or less, Microsoft System Restore is disabled by default.

For more information and steps, see the Get Help app.

 **NOTE:** You must be connected to the Internet to access the Get Help app.

1. Select the **Start** button, and then select the **Get Help** app.
2. Enter the task you want to perform.

Using the HP Cloud Recovery Download Tool to create recovery media (select products only)

You can use the HP Cloud Recovery Download Tool to create HP Recovery media on a bootable USB flash drive.

For details:

- ▲ Go to <http://www.hp.com/support>, search for HP Cloud Recovery, and then select the result that matches the type of computer that you have.



NOTE: If you cannot create recovery media yourself, contact support to obtain recovery discs. Go to <http://www.hp.com/support>, select your country or region, and then follow the on-screen instructions.

Restoring and recovery

You have several options for recovering your system. Choose the method that best matches your situation and level of expertise.



NOTE: Not all methods are available on all products.

Restoring, resetting, and refreshing using Windows tools

Windows offers several options for restoring, resetting, and refreshing the computer.

For details, see [Using Windows tools on page 69](#).

Recovering using HP Recovery media

You can use HP Recovery media to recover the original operating system and software programs that were installed at the factory. On select products, it can be created on a bootable USB flash drive using the HP Cloud Recovery Download Tool.

For details, see [Using the HP Cloud Recovery Download Tool to create recovery media \(select products only\) on page 69](#).



NOTE: If you cannot create recovery media yourself, contact support to obtain recovery discs. Go to <http://www.hp.com/support>, select your country or region, and then follow the on-screen instructions.

To recover your system:

- ▲ Insert the HP Recovery media, and then restart the computer.

Changing the computer boot order

If your computer does not restart using the HP Recovery media, you can change the computer boot order. This is the order of devices listed in BIOS where the computer looks for startup information. You can change the selection to an optical drive or a USB flash drive, depending on the location of your HP Recovery media.

To change the boot order:



IMPORTANT: For a tablet with a detachable keyboard, connect the tablet to the keyboard base before beginning these steps.

1. Insert the HP Recovery media.
2. Access the system **Startup** menu.
 - For computers or tablets with keyboards attached, turn on or restart the computer or tablet, quickly press **esc**, and then press **f9** for boot options.
 - For tablets without keyboards, turn on or restart the tablet, quickly hold down the volume up button, and then select **f9**.

– or –

Turn on or restart the tablet, quickly hold down the volume down button, and then select **f9**.
3. Select the optical drive or USB flash drive from which you want to boot, and then follow the on-screen instructions.

Using HP Sure Recover (select products only)

Select computer models are configured with HP Sure Recover, a PC OS recovery solution built into the hardware and firmware. HP Sure Recover can fully restore the HP OS image without installed recovery software.

Using HP Sure Recover, an administrator or user can restore the system and install:

- Latest version of the operating system
- Platform-specific device drivers
- Software applications, in the case of a custom image

To access the latest documentation for HP Sure Recover, go to <http://www.hp.com/support>. Select **Find your product**, and then follow the on-screen instructions.

9 Using HP PC Hardware Diagnostics

The HP PC Hardware Diagnostics utility allows you to run diagnostics tests to determine whether your computer hardware is running properly. The three versions are HP PC Hardware Diagnostics Windows, HP PC Hardware Diagnostics UEFI (Unified Extensible Firmware Interface), and (for select products only) a firmware feature called Remote HP PC Hardware Diagnostics UEFI.

Using HP PC Hardware Diagnostics Windows (select products only)

HP PC Hardware Diagnostics Windows is a Windows-based utility that allows you to run diagnostic tests to determine whether the computer hardware is functioning properly. The tool runs within the Windows operating system to diagnose hardware failures.

If HP PC Hardware Diagnostics Windows is not installed on your computer, first you must download and install it. To download HP PC Hardware Diagnostics Windows, see [Downloading HP PC Hardware Diagnostics Windows on page 74](#).

Using an HP PC Hardware Diagnostics Windows hardware failure ID code

When HP PC Hardware Diagnostics Windows detects a failure that requires hardware replacement, a 24-digit Failure ID code is generated.

- ▲ Depending on the instructions on the screen, choose one of these options:
 - If failure ID link is displayed, select the link and follow the on-screen instructions.
 - If instructions for calling support are displayed. Follow those instructions.

Accessing HP PC Hardware Diagnostics Windows

After HP PC Hardware Diagnostics Windows is installed, you can access it from HP Help and Support or HP Support Assistant.

Accessing HP PC Hardware Diagnostics Windows from HP Help and Support

After HP PC Hardware Diagnostics Windows is installed, follow these steps to access it from HP Help and Support.

To access HP PC Hardware Diagnostics Windows from HP Help and Support:

1. Select the **Start** button, and then select **HP Help and Support**.
2. Select **HP PC Hardware Diagnostics Windows**.
3. When the tool opens, select the type of diagnostic test that you want to run, and then follow the on-screen instructions.



NOTE: To stop a diagnostic test, select **Cancel**.

Accessing HP PC Hardware Diagnostics Windows from Support Assistant

After HP PC Hardware Diagnostics Windows is installed, follow these steps to access it from HP Support Assistant.

To access HP PC Hardware Diagnostics Windows from HP Support Assistant:

1. Type `support` in the taskbar search box, and then select the **HP Support Assistant** app.
– or –
Select the question mark icon in the taskbar.
2. Select **Troubleshooting and fixes**.
3. Select **Diagnostics**, and then select **HP PC Hardware Diagnostics Windows**.
4. When the tool opens, select the type of diagnostic test that you want to run, and then follow the on-screen instructions.



NOTE: To stop a diagnostic test, select **Cancel**.

Downloading HP PC Hardware Diagnostics Windows

The HP PC Hardware Diagnostics Windows downloading instructions are provided in English only. You must use a Windows computer to download this tool because only .exe files are provided.

Downloading the latest HP PC Hardware Diagnostics Windows version from HP

To download HP PC Hardware Diagnostics Windows from HP, follow these steps.

1. Go to <http://www.hp.com/go/techcenter/pcdiags>. The HP PC Diagnostics home page is displayed.
2. Select **Download HP Diagnostics Windows**, and then select a location on your computer or a USB flash drive.

The tool downloads to the selected location.

Downloading the HP PC Hardware Diagnostics Windows from the Microsoft Store

You can download the HP PC Hardware Diagnostics Windows from the Microsoft Store.

1. Select the Microsoft app on your desktop or enter `Microsoft Store` in the taskbar search box.
2. Enter `HP PC Hardware Diagnostics Windows` in the **Microsoft Store** search box.
3. Follow the on-screen directions.

The tool downloads to the selected location.

Downloading HP Hardware Diagnostics Windows by product name or number (select products only)

You can download HP PC Hardware Diagnostics Windows by product name or number.



NOTE: For some products, you might have to download the software to a USB flash drive by using the product name or number.

1. Go to <http://www.hp.com/support>.
2. Select **Software and Drivers**, select your type of product, and then enter the product name or number in the search box that is displayed.
3. In the **Diagnostics** section, select **Download**, and then follow the on-screen instructions to select the specific Windows diagnostics version to be downloaded to your computer or USB flash drive.

The tool downloads to the selected location.

Installing HP PC Hardware Diagnostics Windows

To install HP PC Hardware Diagnostics Windows, navigate to the folder on your computer or the USB flash drive where the .exe file downloaded, double-click the .exe file, and then follow the on-screen instructions.

Using HP PC Hardware Diagnostics UEFI

HP PC Hardware Diagnostics UEFI (Unified Extensible Firmware Interface) allows you to run diagnostic tests to determine whether the computer hardware is functioning properly. The tool runs outside the operating system so that it can isolate hardware failures from issues that are caused by the operating system or other software components.



NOTE: For Windows 10 S computers, you must use a Windows computer and a USB flash drive to download and create the HP UEFI support environment because only .exe files are provided. For more information, see [Downloading HP PC Hardware Diagnostics UEFI to a USB flash drive on page 76](#).

If your PC does not start in Windows, you can use HP PC Hardware Diagnostics UEFI to diagnose hardware issues.

Using an HP PC Hardware Diagnostics UEFI hardware failure ID code

When HP PC Hardware Diagnostics UEFI detects a failure that requires hardware replacement, a 24-digit Failure ID code is generated.

For assistance in solving the problem:

- ▲ Select **Contact HP**, accept the HP privacy disclaimer, and then use a mobile device to scan the Failure ID code that appears on the next screen. The HP Customer Support - Service Center page appears with your Failure ID and product number automatically filled in. Follow the on-screen instructions.

– or –

Contact support, and provide the Failure ID code.



NOTE: To start diagnostics on a convertible computer, your computer must be in notebook mode, and you must use the attached keyboard.



NOTE: If you need to stop a diagnostic test, press [esc](#).

Starting HP PC Hardware Diagnostics UEFI

To start HP PC Hardware Diagnostics UEFI, follow this procedure.

1. Turn on or restart the computer, and quickly press [esc](#).
2. Press [f2](#).

The BIOS searches three places for the diagnostic tools, in the following order:

- a. Connected USB flash drive

 **NOTE:** To download the HP PC Hardware Diagnostics UEFI tool to a USB flash drive, see [Downloading the latest HP PC Hardware Diagnostics UEFI version on page 76](#).

- b. Hard drive
- c. BIOS

3. When the diagnostic tool opens, select a language, select the type of diagnostic test you want to run, and then follow the on-screen instructions.

Downloading HP PC Hardware Diagnostics UEFI to a USB flash drive

Downloading HP PC Hardware Diagnostics UEFI to a USB flash drive can be useful in some situations.

- HP PC Hardware Diagnostics UEFI is not included in the preinstallation image.
- HP PC Hardware Diagnostics UEFI is not included in the HP Tool partition.
- The hard drive is damaged.

 **NOTE:** The HP PC Hardware Diagnostics UEFI downloading instructions are provided in English only, and you must use a Windows computer to download and create the HP UEFI support environment because only .exe files are provided.

Downloading the latest HP PC Hardware Diagnostics UEFI version

To download the latest HP PC Hardware Diagnostics UEFI version to a USB flash drive, follow this procedure.

1. Go to <http://www.hp.com/go/techcenter/pcdiags>. The HP PC Diagnostics home page is displayed.
2. Select **Download HP Diagnostics UEFI**, and then select **Run**.

Downloading HP PC Hardware Diagnostics UEFI by product name or number (select products only)

You can download HP PC Hardware Diagnostics UEFI by product name or number (select products only) to a USB flash drive.

 **NOTE:** For some products, you might have to download the software to a USB flash drive by using the product name or number.

1. Go to <http://www.hp.com/support>.
2. Enter the product name or number, select your computer, and then select your operating system.
3. In the **Diagnostics** section, follow the on-screen instructions to select and download the specific UEFI Diagnostics version for your computer.

Using Remote HP PC Hardware Diagnostics UEFI settings (select products only)

Remote HP PC Hardware Diagnostics UEFI is a firmware (BIOS) feature that downloads HP PC Hardware Diagnostics UEFI to your computer. It can then execute the diagnostics on your computer, and it might upload results to a preconfigured server.

For more information about Remote HP PC Hardware Diagnostics UEFI, go to <http://www.hp.com/go/techcenter/pcdiags>, and then select **Find out more**.

Downloading Remote HP PC Hardware Diagnostics UEFI

HP Remote PC Hardware Diagnostics UEFI is also available as a SoftPaq that you can download to a server.

Downloading the latest Remote HP PC Hardware Diagnostics UEFI version

You can download the latest HP PC Hardware Diagnostics UEFI version to a USB flash drive.

1. Go to <http://www.hp.com/go/techcenter/pcdiags>. The HP PC Diagnostics home page is displayed.
2. Select **Download Remote Diagnostics**, and then select **Run**.

Downloading Remote HP PC Hardware Diagnostics UEFI by product name or number

You can download HP Remote PC Hardware Diagnostics UEFI by product name or number.



NOTE: For some products, you might have to download the software by using the product name or number.

1. Go to <http://www.hp.com/support>.
2. Select **Software and Drivers**, select your type of product, enter the product name or number in the search box that is displayed, select your computer, and then select your operating system.
3. In the **Diagnostics** section, follow the on-screen instructions to select and download the **Remote UEFI** version for the product.

Customizing Remote HP PC Hardware Diagnostics UEFI settings

Using the Remote HP PC Hardware Diagnostics setting in Computer Setup (BIOS), you can perform the following customizations:

- Set a schedule for running diagnostics unattended. You can also start diagnostics immediately in interactive mode by selecting **Execute Remote HP PC Hardware Diagnostics**.
- Set the location for downloading the diagnostic tools. This feature provides access to the tools from the HP website or from a server that has been preconfigured for use. Your computer does not require the traditional local storage (such as a hard drive or USB flash drive) to run remote diagnostics.
- Set a location for storing the test results. You can also set the user name and password that you use for uploads.
- Display status information about the diagnostics run previously.

To customize Remote HP PC Hardware Diagnostics UEFI settings, follow these steps:

1. Turn on or restart the computer, and when the HP logo appears, press **F10** to enter Computer Setup.
2. Select **Advanced**, and then select **Settings**.
3. Make your customization selections.
4. Select **Main**, and then **Save Changes and Exit** to save your settings.

Your changes take effect when the computer restarts.

10 Specifications

This chapter provides specifications for your computer.

Computer specifications

This section provides specifications for your computer. When traveling with your computer, the computer dimensions and weights, as well as input power ratings and operating specifications, provide helpful information.

Table 10-1 Computer specifications

	Metric	U.S.
Dimensions		
Width	357.7 mm	14.1 in
Depth	239.7 mm	9.4 in
Height	22.5 mm	0.9 in
Weight	2450 g	5.4 lbs
Input power		
Operating voltage and current	19.5 V dc @ 7.70 A – 150 W 19.5 V dc @ 10.3 A – 200 W	
Temperature		
Operating	5°C to 35°C	41°F to 95°F
Nonoperating	-20°C to 60°C	-4°F to 140°F
Relative humidity (noncondensing)		
Operating	10% to 90%	
Nonoperating	5% to 95%	
Maximum altitude (unpressurized)		
Operating	-15 m to 3,048 m	-50 ft to 10,000 ft
Nonoperating	-15 m to 12,192 m	-50 ft to 40,000 ft
NOTE: Applicable product safety standards specify thermal limits for plastic surfaces. The device operates well within this range of temperatures.		

39.6 cm (15.6 in) display specifications

This section provides specifications for your display.

Table 10-2 Display specifications

	Metric	U.S.
Active diagonal size	39.6 cm	15.6 in
Resolution	1920 × 1080 (FHD) 3840 × 2160 (UHD)	
Surface treatment	Antiglare (FHD, UHD panels) Brightview (OLED panel)	
Brightness	250 nits (FHD, 45% NTSC panel) 300 nits (FHD, 72% NTSC/100% sRGB panels) 400 nits (UHD panel)	
Viewing angle	UWVA	
Backlight	WLED AMOLED	
Display panel interface	eDP	

Solid-state drive specifications

This section provides specifications for your solid-state drives.

Table 10-3 Solid-state drive specifications

	256 GB*	512 GB*	1 TB*
Dimensions			
Height	1.0 mm	1.0 mm	1.0 mm
Length	50.8 mm	50.8 mm	50.8 mm
Width	28.9 mm	28.9 mm	28.9 mm
Weight	< 10 g	< 10 g	< 10 g
Interface type			
Ready time, maximum (to not busy)	1.0 ms	< 1.0 ms	1.0 ms
Access times, logical	0.1 ms	0.1 ms	0.1 ms
Transfer rate			
Sequential read	up to 2150 MB/s	up to 2150 MB/s	up to 2150 MB/s
Random read	Up to 300,000 IOPs	Up to 300,000 IOPs	Up to 300,000 IOPs
Sequential write	up to 1550 MB/s	up to 1550 MB/s	up to 1550 MB/s
Random write	Up to 100,000 IOPs	Up to 100,000 IOPs	Up to 100,000 IOPs
Total logical sectors	468,883,296	1,000,215,216	1,500,336,388
Operating temperature	0°C to 70°C (32°F to 158°F)		

Table 10-3 Solid-state drive specifications (continued)

	256 GB*	512 GB*	1 TB*
<p>*1 GB = 1 billion bytes when referring to hard drive storage capacity. Actual accessible capacity is less. Actual drive specifications may differ slightly.</p>			
<p>NOTE: Certain restrictions and exclusions apply. Contact support for details.</p>			

11 Power cord set requirements

This chapter provides power cord requirements for countries and regions.

The wide-range input feature of the computer permits it to operate from any line voltage from 100 V ac to 120 V ac, or from 220 V ac to 240 V ac.

The 3-conductor power cord set included with the computer meets the requirements for use in the country or region where the equipment is purchased.

Power cord sets for use in other countries or regions must meet the requirements of the country and region where the computer is used.

Requirements for all countries

These power cord requirements are applicable to all countries and regions.

- The length of the power cord set must be at least **1.0 m** (3.3 ft) and no more than **2.0 m** (6.5 ft).
- All power cord sets must be approved by an acceptable accredited agency responsible for evaluation in the country or region where the power cord set will be used.
- The power cord sets must have a minimum current capacity of 10 A and a nominal voltage rating of 125 V ac or 250 V ac, as required by the power system of each country or region.
- The appliance coupler must meet the mechanical configuration of an EN 60 320/IEC 320 Standard Sheet C13 connector for mating with the appliance inlet on the back of the computer.

Requirements for specific countries and regions

To determine power cord requirements for specific countries and regions, use this table.

Table 11-1 Power cord requirements for specific countries and regions

Country/region	Accredited agency	Applicable note number
Argentina	IRAM	1
Australia	SAA	1
Austria	OVE	1
Belgium	CEBEC	1
Brazil	ABNT	1
Canada	CSA	2
Chile	IMQ	1
Denmark	DEMKO	1
Finland	FIMKO	1
France	UTE	1
Germany	VDE	1

Table 11-1 Power cord requirements for specific countries and regions (continued)

Country/region	Accredited agency	Applicable note number
India	BIS	1
Israel	SII	1
Italy	IMQ	1
Japan	JIS	3
The Netherlands	KEMA	1
New Zealand	SANZ	1
Norway	NEMKO	1
The People's Republic of China	CCC	4
Saudi Arabia	SASO	7
Singapore	PSB	1
South Africa	SABS	1
South Korea	KTL	5
Sweden	SEMKO	1
Switzerland	SEV	1
Taiwan	BSMI	6
Thailand	TISI	1
The United Kingdom	ASTA	1
The United States	UL	2

1. The flexible cord must be Type H05VV-F, 3-conductor, 0.75 mm² conductor size. Power cord set fittings (appliance coupler and wall plug) must bear the certification mark of the agency responsible for evaluation in the country or region where it will be used.
2. The flexible cord must be Type SVT/SJT or equivalent, No. 18 AWG, 3-conductor. The wall plug must be a two-pole grounding type with a NEMA 5-15P (15 A, 125 V ac) or NEMA 6-15P (15 A, 250 V ac) configuration. CSA or C-UL mark. UL file number must be on each element.
3. The appliance coupler, flexible cord, and wall plug must bear a T mark and registration number in accordance with the Japanese Dentori Law. The flexible cord must be Type VCTF, 3-conductor, 0.75 mm² or 1.25 mm² conductor size. The wall plug must be a two-pole grounding type with a Japanese Industrial Standard C8303 (7 A, 125 V ac) configuration.
4. The flexible cord must be Type RVV, 3-conductor, 0.75 mm² conductor size. Power cord set fittings (appliance coupler and wall plug) must bear the CCC certification mark.
5. The flexible cord must be Type H05VV-F 3-conductor, 0.75 mm² conductor size. KTL logo and individual approval number must be on each element. Approval number and logo must be printed on a flag label.
6. The flexible cord must be Type HVCTF 3-conductor, 1.25 mm² conductor size. Power cord set fittings (appliance coupler, cable, and wall plug) must bear the BSMI certification mark.
7. For 127 V ac, the flexible cord must be Type SVT or SJT 3-conductor, 18 AWG, with plug NEMA 5-15P (15 A, 125 V ac), with UL and CSA or C-UL marks. For 240 V ac, the flexible cord must be Type H05VV-F 3-conductor, 0.75 mm² or 1.00 mm² conductor size, with plug BS 1363/A with BSI or ASTA marks.

12 Recycling

When a nonrechargeable or rechargeable battery has reached the end of its useful life, do not dispose of the battery in general household waste. Follow the local laws and regulations in your area for battery disposal.

HP encourages customers to recycle used electronic hardware, HP original print cartridges, and rechargeable batteries. For more information about recycling programs, see the HP website at <http://www.hp.com/recycle>.

Index

A

- AC adapter and battery light, identifying 6
- AC adapters, spare part numbers 22
- audio, product description 2

B

- backup, creating 69
- backups 69
- battery
 - illustrated 17
 - spare part number 17
 - spare part numbers 17
- BIOS
 - determining version 65
 - downloading an update 66
 - starting the Setup Utility 65
 - updating 65

- Bluetooth label 14
- boot order, changing 70
- bottom components 13
- bottom cover
 - illustrated 17
 - removal 31
 - spare part number 17, 31
- buttons
 - left touchpad 9
 - power 10
 - right touchpad 9

C

- cables
 - spare part numbers 21
- camera
 - identifying 7
- camera light, identifying 7
- caps lock light 9
- card reader/audio board
 - illustrated 17
 - removal 41
 - spare part number 17
 - spare part numbers 41
- card reader/audio board cable
 - spare part number 21

- cautions
 - electrostatic discharge 25, 26
- components
 - bottom 13
 - display 7
 - keyboard area 8
 - left side 6
 - rear 7
 - right side 5
- computer major components 17
- computer specifications 79
- connectors
 - power 6

D

- display
 - specifications 79
- display assembly
 - subcomponents 17, 20
- display back cover
 - illustrated 20
 - spare part number 20
- display bezel
 - illustrated 20
 - spare part number 20
- display cable
 - illustrated 20
 - spare part number 20
- display components 7
- display panel
 - illustrated 20
 - spare part number 20
- DisplayPort connector, identifying 5

E

- electrostatic discharge (ESD) 25, 26
 - preventing damage 25, 26, 27
- esc key, identifying 11

F

- fan
 - removal 45
 - spare part number 17, 45

fans

- illustrated 17
- spare part number 17
- fingerprint reader module
 - spare part number 17
- fn key, identifying 11

G

- grounding methods 25, 26, 28
- guidelines
 - packaging 25, 29
 - transporting 25, 29
 - workstation 25, 26

H

- hard drive
 - spare part numbers 17
 - specifications 79
- HDMI port
 - identifying 6
- heat sink
 - illustrated 17
 - removal 42
 - spare part number 17
 - spare part numbers 17, 42
- hinge
 - illustrated 20
 - spare part number 20
- hinge cover
 - illustrated 20
 - spare part number 20
- HP OMEN Command Center 14
- HP PC Hardware Diagnostics UEFI
 - downloading 76
 - starting 75
 - using 75
- HP PC Hardware Diagnostics Windows
 - accessing 73, 74
 - downloading 74
 - installing 75
 - using 73
- HP Recovery media
 - recovery 70
- HP Sure Recover 71

- I**
- integrated numeric keypad, identifying 11
- internal microphones, identifying 7
- IR board
 - illustrated 17
 - removal 50
 - spare part number 17
 - spare part numbers 50
- IR board cable
 - spare part number 21
- J**
- jacks
 - network 6
 - RJ-45 (network) 6
- K**
- keyboard with top cover
 - spare part numbers 62
- keypad, integrated numeric 11
- keys
 - action 11
 - esc 11
 - fn 11
 - num lock 11
 - Windows 11
 - Windows application 11
- L**
- labels
 - Bluetooth 14
 - regulatory 14
 - serial number 14
 - service 14
 - wireless certification 14
 - WLAN 14
- left side components 6
- lights
 - AC adapter and battery 6
 - camera 7
 - caps lock 9
 - mute 9
 - power 9
 - RJ-45 (network) status 6
 - touchpad 9
- M**
- memory modules
 - removal 34
- spare part number 17
- spare part numbers 34
- mute light, identifying 9
- N**
- network jack, identifying 6
- O**
- OMEN Command Center 14
- P**
- packaging guidelines 25, 29
- ports
 - DisplayPort connector 5
 - HDMI 6
 - product description 2
 - USB 5
 - USB SuperSpeed 5
 - USB Type-C 5
 - USB Type-C power connector and Thunderbolt port with HP Sleep and Charge 5
 - USB Type-C SuperSpeed with HP Sleep and Charge 5
 - USB Type-C Thunderbolt port with HP Sleep and Charge 5
- power button, identifying 10
- power connector
 - identifying 6
- power connector cable
 - illustrated 17
 - removal 39
 - spare part number 17
 - spare part numbers 39
- power cord
 - requirements for all countries 83
 - requirements for specific countries and regions 83
 - set requirements 83
- power cords, spare part numbers 22
- power light, identifying 9
- power requirements, product description 3
- product description
 - audio 2
 - microphone 2
 - ports 2
 - power requirements 3
 - video 2
- product name and number, computer 14
- R**
- rear components 7
- recovery 69, 70
 - discs 70
 - media 70
 - USB flash drive 70
- recovery media 69
 - creating using HP Cloud Recovery Download Tool 69
 - creating using Windows tools 69
- regulatory information
 - regulatory label 14
 - wireless certification labels 14
- Remote HP PC Hardware Diagnostics UEFI settings
 - customizing 77
 - using 76
- removal and replacement
 - solid-state drive 32
- removal/replacement
 - procedures 31, 37
- restoring 69
- RGB board
 - illustrated 17
 - spare part number 17
- RGB board cable
 - spare part number 21
- RGB keyboard control board
 - removal 38
 - spare part numbers 38
- right side components 5
- RJ-45 (network) jack, identifying 6
- RJ-45 (network) status lights, identifying 6
- RJ-45 door
 - illustrated 17
 - removal 47
 - spare part number 17
 - spare part numbers 47
- rtc battery
 - spare part number 17
- S**
- Screw Kit, spare part number 22
- serial number, computer 14
- service labels, locating 14

- slots
 - memory card reader 6
- solid-state drive
 - illustrated 17
 - removal and replacement 32
 - spare part number 17
 - specifications 80
- spare part country codes 62
- speaker
 - illustrated 17
 - removal 40
 - spare part number 17
 - spare part numbers 40
- speakers
 - spare part numbers 17
- speakers, identifying 13
- special keys, using 11
- specifications
 - computer 79
 - display 79
 - hard drive 79
 - solid-state drive 80
- static electricity 25, 26, 27
- system board
 - illustrated 17
 - removal 48
 - spare part number 17
 - spare part numbers 48
- system restore point, creating 69

T

- top cover/keyboard
 - illustrated 17
 - spare part number 17
 - spare part numbers 17
- touchpad
 - illustrated 17
 - removal 51
 - spare part number 17
 - spare part numbers 51
- touchpad buttons
 - identifying 9
- touchpad cable
 - spare part number 21
- touchpad light, identifying 9
- touchpad zone, identifying 9
- transporting guidelines 25, 29
- traveling with the computer 14

U

- USB board
 - illustrated 17
 - removal 46
 - spare part number 17
 - spare part numbers 46
- USB board cable
 - spare part number 21
- USB port, identifying 5
- USB Type-C port, identifying 5
- USB Type-C SuperSpeed port with HP Sleep and Charge, identifying 5
- USB Type-C Thunderbolt port with HP Sleep and Charge, identifying 5

V

- vent, identifying 7, 13
- video, product description 2

W

- Windows
 - backup 69
 - recovery media 69
 - system restore point 69
- Windows application key, identifying 11
- Windows key, identifying 11
- Windows tools, using 69
- wireless antennas
 - illustrated 20
 - spare part number 20
- wireless antennas, identifying 7
- wireless certification label 14
- WLAN antennas, identifying 7
- WLAN device 14
- WLAN label 14
- WLAN module
 - spare part number 17
- workstation guidelines 25, 26

