



Maintenance and Service Guide

SUMMARY

This guide provides information about spare parts, removal and replacement of parts, security, backing up, and more.

© Copyright 2020 HP Development Company, L.P.

Bluetooth is a trademark owned by its proprietor and used by HP Inc. under license. Chrome, Chromebox, and Google, are trademarks of Google LLC. Intel, Celeron, Core, Pentium, Thunderbolt, and vPro are trademarks of Intel Corporation or its subsidiaries in the U.S. and/or other countries. The SD Logo and microSD are trademarks of its proprietor. USB Type-C and USB-C are registered trademarks of USB Implementers Forum.

The information contained herein is subject to change without notice. The only warranties for HP products and services are set forth in the express warranty statements accompanying such products and services. Nothing herein should be construed as constituting an additional warranty. HP shall not be liable for technical or editorial errors or omissions contained herein.

First Edition: November 2020

Document Part Number: M27977-001

Product notice

This guide describes features that are common to most models. Some features may not be available on your Chromebook.

To access the latest user guides, go to <http://www.hp.com/support>, and follow the instructions to find your product. Then select **Manuals**.

Software terms

By installing, copying, downloading, or otherwise using any software product preinstalled on this Chromebook, you agree to be bound by the terms of the HP End User License Agreement (EULA). If you do not accept these license terms, your sole remedy is to return the entire unused product (hardware and software) within 14 days for a full refund subject to the refund policy of your seller.

For any further information or to request a full refund of the price of the Chromebook, please contact your seller.

Table of contents

1 Product description	1
2 Getting to know your Chromebox	5
Right	5
Front	6
Rear	7
Bottom	8
Labels	9
3 Illustrated parts catalog	13
Chromebox major components	13
Miscellaneous parts	15
4 Removal and replacement procedures preliminary requirements	17
Tools required	17
Service considerations	18
Plastic parts	18
Cables and connectors	18
Drive handling	18
Workstation guidelines	18
5 Electrostatic discharge information	21
Generating static electricity	21
Preventing electrostatic damage to equipment	22
Personal grounding methods and equipment	22
Grounding the work area	23
Recommended materials and equipment	23
6 Removal and replacement procedures for authorized service provider parts	25
Component replacement procedures	26
Preparation for disassembly	27

Bottom cover	27
I/O side frame	28
Bottom shield	29
Power connector cable	30
WLAN module	31
Solid-state drive	33
Memory module	33
System board	35
Fan	37
Heat sink	38
Top shield	39
Power button board	40
7 Specifications	43
Chromebook specifications	43
Solid-state drive specifications	45
8 Power cord set requirements	47
Requirements for all countries	47
Requirements for specific countries and regions	47
9 Recycling	51
Index	53

1 Product description

This table provides detailed product information.

Table 1-1 Product components and their descriptions

Category	Description
Product Name	HP Chromebox G3
Processors	<ul style="list-style-type: none">Intel™ Core® i7-1061U 1.8 GHz (5C turbo up to 4.9 GHz) processor (2666 MHz front side bus (FSB), quad core, 8 MB L3 cache, 15 W)Intel Core i5-1031U 1.7 GHz (5C turbo up to 4.4 GHz) processor (2666 MHz FSB, quad core, 6 MB L3 cache, 15 W)Intel Core i3-1011U 2.1 GHz (5C turbo up to 4.1 GHz) processor (2666 MHz FSB, dual core, 4 MB L3 cache, 15 W)Intel Pentium® 6405U 2.4 GHz processor (2400 MHz FSB, dual core, 2 MB L3 cache, 15 W)Intel Celeron® 5205U 1.9 GHz processor (2400 MHz FSB, dual core, 2 MB L3 cache, 15 W)
Chipset	Intel integrated soldered-on-circuit (SoC)
Graphics controller	Intel UHD 620 integrated graphics on Chromebook models equipped with an Intel Core i7 or Intel Core i5 processor Intel UHD integrated graphics on Chromebook models equipped with an Intel Core i3, Intel Pentium, or Intel Celeron processor
Media card reader	HP 3-in-1 card reader
Memory	DDR4-2666 dual-channel SODIMM support Supports the following configurations: <ul style="list-style-type: none">16 GB (2 × 8 GB)8 GB (2 × 4 GB)8 GB (1 × 8 GB)4 GB (1 × 4 GB)
MultiMedia card	eMMC 64 GB M0-276 MMC v 5.0
Primary storage	Solid-state drive: 128 GB, 2280, peripheral component interconnect express (PCIe), nonvolatile memory express (NVMe), value solid-state drive eMMC: Embedded multimedia controller (eMMC) 32 GB M0-276 MMC v 5.0

Table 1-1 Product components and their descriptions (continued)

Category	Description
Connectors	<ul style="list-style-type: none"> • Audio-out (headphone)/Audio-in (microphone) combo jack • HDMI ports (2) • microSD • Power connector • RJ-45 (network) jack • USB 2.0 port • USB SuperSpeed port • USB SuperSpeed port with HP Sleep and Charge (2) • USB Type-C® Thunderbolt™ port with HP Sleep and Charge • Next generation form factor (NGFF) connector for solid-state drive (inside Chromebox) • NGFF connector for WLAN module (inside Chromebox)
Audio	<p>Realtek ALC5662 high-definition (HD) audio codec</p> <p>HP 3.5 mm business headset</p> <p>HP wired USB Type-A stereo headset</p>
Wireless	<p>Intel 2 Wi-Fi 6 AX201 ax 2x2 + Bluetooth® 5 MU-MIMO M.2 2230 non-vPro® MIPI+BRI WW with two antennas</p> <p>10/100/1000M GbE local area network (LAN)</p> <p>eMMC 64 GB M0-276 MMC v 5.0</p>
Keyboard/pointing devices	<p>USB Chrome™ standalone wired keyboard and mouse combo</p> <p>HP Bluetooth travel mouse</p> <p>HP USB comfort grip wireless mouse</p> <p>HP USB 3-button laser mouse</p>
Power requirements	<p>AC adapters:</p> <ul style="list-style-type: none"> • 90 W HP Smart Adapter (4.5 mm) • 90 W HP Smart Adapter (PFC, standard barrel, right angle, 4.5 mm) • 65 W HP Smart Adapter (non-PFC, EM, standard barrel, 4.5 mm) • 65 W HP Smart Adapter (non-PFC, EM, standard barrel, 4.5 mm) • 65 W HP Smart Adapter (non-PFC, standard barrel, 4.5 mm, right angle, 1.8 m [6.0 ft]) • 65 W HP USB Type-C LC AC adapter <p>Power cord: C5, 1.0 m (3.3 ft), conventional with sticker</p>
Security	<ul style="list-style-type: none"> • HP combination standard lock • HP master keyed standard cable lock • H1 Secure Microcontroller

Table 1-1 Product components and their descriptions (continued)

Category	Description
Operating system	Chrome 64
Serviceability	End user replaceable part: AC adapter

2 Getting to know your Chromebox

Your Chromebox features top-rated components. This chapter provides details about your components, where they are located, and how they work.

Right

Use the illustration and table to identify the components on the right side of the Chromebox.

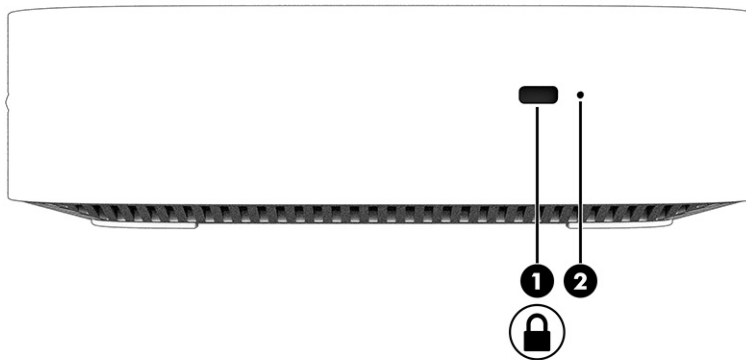

Table 2-1 Right-side components and their descriptions

Component	Description
(1) Security cable lock	Attaches an optional security cable to the Chromebox. NOTE: The security cable is designed to act as a deterrent, but it might not prevent the Chromebox from being mishandled or stolen.
(2) Reset/recovery button	To reset or recover the device, insert a paper clip (or pushpin) into the reset/recovery button hole, and then press the button. NOTE: Pressing this button with the power button deletes all account information and data stored on your device, such as photos, downloaded files, and saved networks. HP recommends that you save files to an external hard drive, USB flash drive, or cloud storage for this reason. You can save your files to the cloud at any time by selecting the Google Drive™ location as your file-save location.

Front

Use the illustration and table to identify the components on the front of the Chromebox.

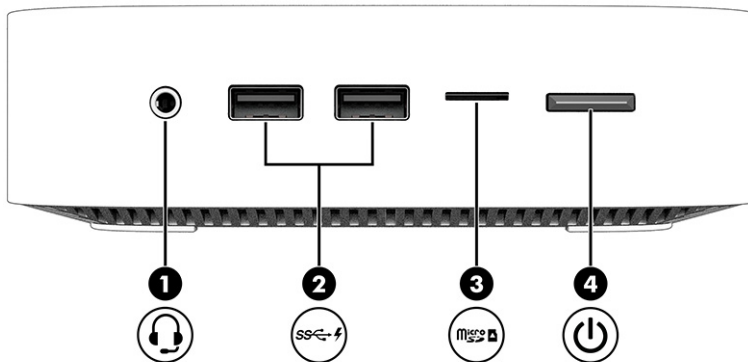

Table 2-2 Front-side components and their descriptions





Component	Description
(1)  Audio-out (headphone)/Audio-in (microphone) combo jack	Connects optional powered stereo speakers, headphones, earbuds, a headset, or a television audio cable. Also connects an optional headset microphone. This jack does not support optional standalone microphones. WARNING! To reduce the risk of personal injury, adjust the volume before putting on headphones, earbuds, or a headset. For additional safety information, see the <i>Regulatory, Safety, and Environmental Notices</i> . NOTE: When a device is connected to the jack, the Chromebox™ speakers are disabled.
(2)  USB SuperSpeed charging port	Connects a USB device, provides data transfer, and (for select products) charges small devices (such as a smartphone) when the Chromebox is on or in Sleep mode.

Table 2-2 Front-side components and their descriptions (continued)

Component	Description
<p>(3)  microSD™ memory card reader</p>	<p>Reads optional memory cards that store, manage, share, or access information.</p> <p>To insert a card:</p> <ol style="list-style-type: none"> 1. Hold the card label-side up, with the connectors facing the Chromebox. 2. Insert the card into the memory card reader, and then press in on the card until it is firmly seated. <p>To remove a card:</p> <ul style="list-style-type: none"> ▲ Press in on the card, and then remove it from the memory card reader.
<p>(4)  Power button</p>	<ul style="list-style-type: none"> • When the Chromebox is off, press the button briefly to turn on the Chromebox. • When the Chromebox is on, press the button briefly to initiate Sleep. • When the Chromebox is in the Sleep state, press the button briefly to exit Sleep (select products only). • When the Chromebox is in Hibernation, press the button briefly to exit Hibernation. <p>IMPORTANT: Pressing and holding down the power button results in the loss of unsaved information.</p> <p>If the Chromebox has stopped responding and shutdown procedures are ineffective, press and hold the power button for at least 10 seconds to turn off the Chromebox.</p>

Rear

Use the illustration and table to identify the components on the rear of the Chromebox.

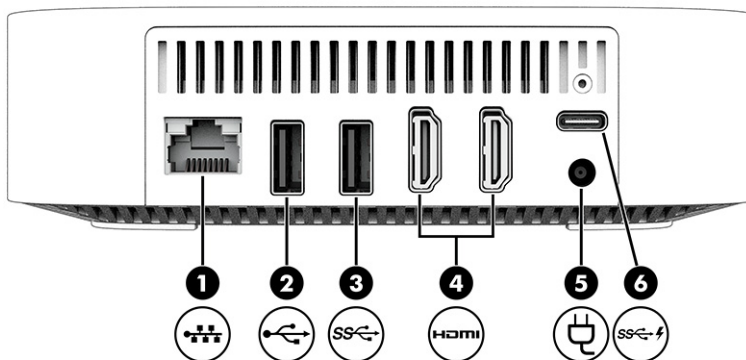







Table 2-3 Rear-side components and their descriptions

Component	Description
(1) RJ-45 (network) jack	Connects a network cable.

Table 2-3 Rear-side components and their descriptions (continued)

Component	Description
(2)  USB port	<p>Connects a USB device, provides data transfer, and (for select products) charges small devices (such as a smartphone) when the Chromebook is on or in Sleep mode.</p> <p>NOTE: Use a standard USB Type-A charging cable or cable adapter (purchased separately) when charging a small external device.</p>
(3)  USB Type-A SuperSpeed port	<p>Connects a USB device, provides data transfer, and (for select products) charges small devices (such as a smartphone) when the Chromebook is on or in Sleep mode.</p> <p>NOTE: Use a standard USB Type-A charging cable or cable adapter (purchased separately) when charging a small external device.</p>
(4)  HDMI ports (2)	<p>Connects an optional video or audio device, such as a high-definition television, any compatible digital or audio component, or a high-speed High Definition Multimedia Interface (HDMI) device.</p>
(5)  AC adapter and battery light	<ul style="list-style-type: none"> • White: The AC adapter is connected and the battery is fully charged. • Amber: The AC adapter is connected and the battery is charging. • Blinking amber: The battery has an error. • Off: The battery is not charging.
(6)  USB Type-C SuperSpeed charging port	<p>Connects a USB device, provides data transfer, and (for select products) charges small devices (such as a smartphone) when the Chromebook is on or in Sleep mode.</p>

Bottom

Use the illustration and table to identify the bottom components.



Table 2-4 Bottom component and description

Components	Description
Vent	Enables airflow to cool internal components. NOTE: The fan starts automatically to cool internal components and prevent overheating. It is normal for the internal fan to cycle on and off during routine operation.

Labels

The labels affixed to the Chromebox provide information that might be needed when troubleshooting system problems or traveling internationally with the device. Labels can be in paper form or imprinted on the product.

 **IMPORTANT:** Check the bottom of the Chromebox for the correct label.

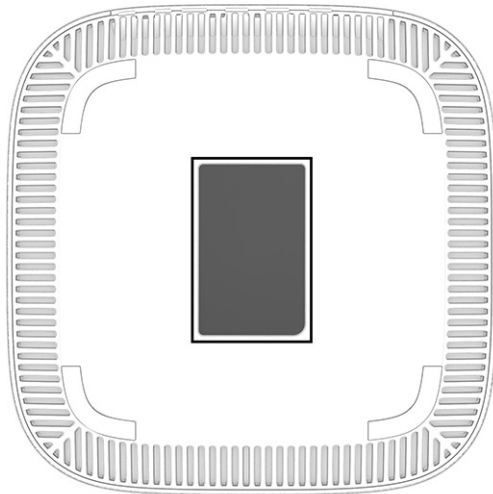

- Service label—Provides important information to identify your device. When contacting support, you might be asked for the serial number, the product number, or the model number. Locate this information before you contact support. The service label might vary from the following illustrations.

The following label represents North American, Latin American, European, Middle Eastern, and African countries and regions.



The following label below represents Asia Pacific and Japan 1 countries and regions.

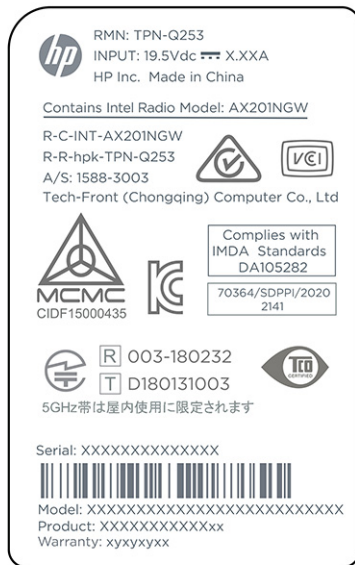

The following label below represents Asia Pacific and Japan 2 countries and regions.



- Regulatory labels—Provide regulatory information about the device.
- Wireless certification labels—Provide information about optional wireless devices and the approval markings for the countries or regions in which the devices have been approved for use.

3 Illustrated parts catalog

Use this table to determine the spare parts that are available for the Chromebook.

Chromebox major components

To identify the Chromebox major components, use this illustration and table.

NOTE: HP continually improves and changes product parts. For complete and current information about supported parts for your Chromebox, go to <http://partsurfer.hp.com>, select your country or region, and then follow the on-screen instructions.

NOTE: Details about your Chromebox, including model, serial number, product key, and length of warranty, are on the service tag at the bottom of your Chromebox.

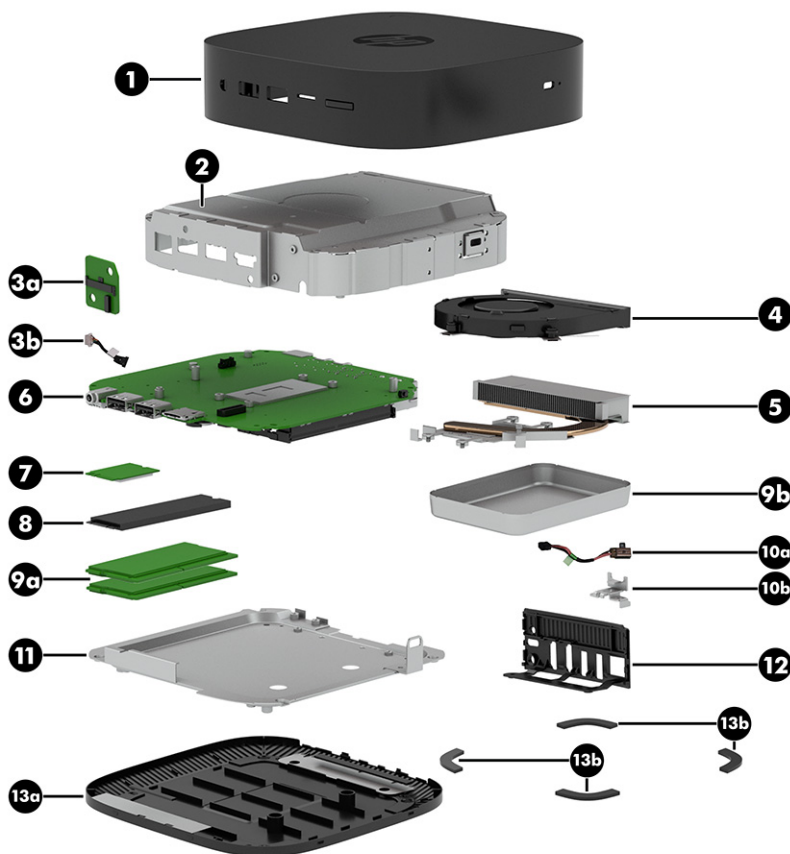

Table 3-1 Chromebox major component descriptions and part numbers

Item	Component	Spare part number
(1)	Top cover	L17257-001
(2)	Top shield (includes wireless antenna)	M24725-001
(3a)	Power button board	M24724-001
	NOTE: The power button board spare part kit does not include the power button board cable. The power button board cable is available using spare part number M42089-001.	
(3b)	Power button board cable	M42089-001
(4)	Fan (includes cable)	M24727-001
(5)	Heat sink (15 W, includes replacement thermal material)	M24726-001
(6)	System board (includes processor, RTC battery, replacement thermal material, graphics subsystem with UMA memory, and Chrome operating system):	
	Equipped with an Intel Core i7-10610U processor	M24721-001
	Equipped with an Intel Core i5-10310U processor and 64 GB on-board system memory	M25770-001
	Equipped with an Intel Core i5-10310U processor	M24720-001
	Equipped with an Intel Core i3-10110U processor and 64 GB on-board system memory	M25769-001
	Equipped with an Intel Core i3-10110U processor	M24719-001
	Equipped with an Intel Pentium 6405U processor and 64 GB on-board system memory	M25771-001
	Equipped with an Intel Pentium 6405U processor and 32 GB on-board system memory	M24722-001
	Equipped with an Intel Celeron 5205U processor and 64 GB on-board system memory	M25768-001
	Equipped with an Intel Celeron 5205U processor and 32 GB on-board system memory	M24718-001
(7)	Intel Wi-Fi 6 AX201 ax 2x2 + Bluetooth 5 MU-MIMO M.2 2230 non-vPro MIPI+BRI WW with 2 antennas WLAN module	L57250-005
(8)	128 GB, 2230, PCIe, NVMe, value solid-state drive	M11040-005
	Solid-state drive absorber (not illustrated)	M24278-001
(9a)	Memory module (DDR4, 3200 GHz, 1.2 V):	
	8 GB	L46598-005
	4 GB	L83673-005
(9b)	Memory shield	L17264-001
	Memory protective strip (not illustrated)	M24723-001
(10a)	Power connector cable	L17259-001
(10b)	Power connector cable bracket	M42090-001
	Power connector cable gasket (not illustrated)	L17265-001
(11)	Bottom shield	M41139-001
	Shield Kit (not illustrated, includes bottom shield front and rear protective strips)	L20217-001
(12)	I/O side frame	M24729-001

Table 3-1 Chromebox major component descriptions and part numbers (continued)

Item	Component	Spare part number
(13a)	Bottom cover	L17258-001
(13b)	Rubber Feet Kit	L17271-001

Miscellaneous parts

To identify the miscellaneous parts, use this table.

Table 3-2 Miscellaneous part descriptions and part numbers

Component	Spare part number
AC adapter:	
90 W AC adapter (PFC, S-3P, 4.5 mm)	710413-001
65 W HP Smart Adapter (non-PFC, EM, RC, 4.5 mm)	913691-850
65 W AC adapter (non-PFC, S-3P, 4.5 mm)	710412-001
Power cord (C5, 1.0 m [3.3 ft], conventional with sticker):	
For use in Australia	L19358-001
For use in Brazil	L19359-001
For use in Denmark	L19360-001
For use in Europe	L19361-001
For use in India	L19363-001
For use in Israel	L19362-001
For use in Italy	L19364-001
For use in Japan	L19365-001
For use in North America	L19367-001
For use in South Africa	L19369-001
For use in South Korea	L19366-001
For use in Switzerland	L19370-001
For use in Taiwan	L19372-001
For use in Thailand	L19371-001
For use in the United Kingdom	L19373-001
Screw Kit	M24730-001

4 Removal and replacement procedures preliminary requirements

Use this information to properly prepare to disassemble and reassemble the Chromebox.

Tools required

You need the following tools to complete the removal and replacement procedures:

- Tweezers
- Case utility tool or similar thin, nonmarking, plastic tool
- Flat-bladed screwdriver
- Magnetic Phillips P0 and P1 screwdrivers
- Suction cups

Service considerations

The following sections include some of the considerations that you must keep in mind during disassembly and assembly procedures.

 **NOTE:** As you remove each subassembly from the Chromebox, place the subassembly (and all accompanying screws) away from the work area to prevent damage.

Plastic parts

Using excessive force during disassembly and reassembly can damage plastic parts.

Cables and connectors

Handle cables with extreme care to avoid damage.

 **IMPORTANT:** When servicing the Chromebox, be sure that cables are placed in their proper locations during the reassembly process. Improper cable placement can damage the Chromebox.

Apply only the tension required to unseat or seat the cables during removal and insertion. Handle cables by the connector whenever possible. In all cases, avoid bending, twisting, or tearing cables. Be sure that cables are routed so that they cannot be caught or snagged as you remove or replace parts. Handle flex cables with extreme care; these cables tear easily.

Drive handling

Note the following guidelines when handling drives.

 **IMPORTANT:** Drives are fragile components. Handle them with care. To prevent damage to the Chromebox, damage to a drive, or loss of information, observe these precautions:

Before removing or inserting a hard drive, shut down the Chromebox. If you are unsure whether the Chromebox is off or in Hibernation, turn the Chromebox on, and then shut it down through the operating system.

Before handling a drive, be sure that you are discharged of static electricity. While handling a drive, avoid touching the connector.

Before removing an optical drive, be sure that a disc is not in the drive, and be sure that the optical drive tray is closed.

Handle drives on surfaces covered with at least 2.54 cm (1 inch) of shock-proof foam.

Avoid dropping drives from any height onto any surface.

After removing a hard drive or an optical drive, place it in a static-proof bag.

Avoid exposing an internal hard drive to products that have magnetic fields, such as monitors or speakers.

Avoid exposing a drive to temperature extremes or liquids.

If a drive must be mailed, place the drive in a bubble pack mailer or other suitable form of protective packaging, and label the package "FRAGILE."

Workstation guidelines

Follow these grounding workstation guidelines:

- Cover the workstation with approved static-shielding material.
- Use a wrist strap connected to a properly grounded work surface and use properly grounded tools and equipment.
- Use conductive field service tools, such as cutters, screw drivers, and vacuums.
- When fixtures must directly contact dissipative surfaces, use fixtures made only of static-safe materials.
- Keep the work area free of nonconductive materials, such as ordinary plastic assembly aids and polystyrene foam.
- Handle ESD-sensitive components, parts, and assemblies by the case or PCM laminate. Handle these items only at static-free workstations.
- Avoid contact with pins, leads, or circuitry.
- Turn off power and input signals before inserting or removing connectors or test equipment.

5 Electrostatic discharge information

A sudden discharge of static electricity from your finger or other conductor can destroy static-sensitive devices or microcircuitry. Often the spark is neither felt nor heard, but damage occurs. An electronic device exposed to electrostatic discharge (ESD) might not appear to be affected at all and can work perfectly throughout a normal cycle. The device might function normally for a while, but it has been degraded in the internal layers, reducing its life expectancy.

Networks built into many integrated circuits provide some protection, but in many cases, the discharge contains enough power to alter device parameters or melt silicon junctions.

 **IMPORTANT:** To prevent damage to the device when you remove or install internal components, observe these precautions:

Keep components in their electrostatic-safe containers until you are ready to install them.

Before touching an electronic component, discharge static electricity by using the guidelines described [Personal grounding methods and equipment on page 22](#).

Avoid touching pins, leads, and circuitry. Handle electronic components as little as possible.

If you remove a component, place it in an electrostatic-safe container.

Generating static electricity

Follow these static electricity guidelines.

- Different activities generate different amounts of static electricity.
- Static electricity increases as humidity decreases.

Table 5-1 Static electricity occurrence based on activity and humidity

Event	Relative humidity		
	55%	40%	10%
Walking across carpet	7,500 V	15,000 V	35,000 V
Walking across vinyl floor	3,000 V	5,000 V	12,000 V
Motions of bench worker	400 V	800 V	6,000 V
Removing DIPs (dual in-line packages) from plastic tube	400 V	700 V	2,000 V

Table 5-1 Static electricity occurrence based on activity and humidity (continued)

	Relative humidity		
Removing DIPs from vinyl tray	2,000 V	4,000 V	11,500 V
Removing DIPs from polystyrene foam	3,500 V	5,000 V	14,500 V
Removing bubble pack from PCB (printed circuit board)	7,000 V	20,000 V	26,500 V
Packing PCBs in foam-lined box	5,000 V	11,000 V	21,000 V

Multiple electric components can be packaged together in plastic tubes, trays, or polystyrene foam.

 **NOTE:** As little as 700 V can degrade a product.

Preventing electrostatic damage to equipment

Many electronic components are sensitive to ESD. Circuitry design and structure determine the degree of sensitivity. The following packaging and grounding precautions are necessary to prevent static electricity damage to electronic components.

- To avoid hand contact, transport products in static-safe containers such as tubes, bags, or boxes.
- Protect all electrostatic parts and assemblies with conductive or approved containers or packaging.
- Keep electrostatic-sensitive parts in their containers until they arrive at static-free stations.
- Place items on a grounded surface before removing them from their container.
- Always be properly grounded when touching a sensitive component or assembly.
- Avoid contact with pins, leads, or circuitry.
- Place reusable electrostatic-sensitive parts from assemblies in protective packaging or conductive foam.

Personal grounding methods and equipment

Using certain equipment can prevent static electricity damage to electronic components.

- **Wrist straps** are flexible straps with a maximum of $1\text{ M}\Omega \pm 10\%$ resistance in the ground cords. To provide proper ground, a strap must be worn snug against bare skin. The ground cord must be connected and fit snugly into the banana plug connector on the grounding mat or workstation.
- **Heel straps/Toe straps/Boot straps** can be used at standing workstations and are compatible with most types of shoes or boots. On conductive floors or dissipative floor mats, use them on both feet with a maximum of $1\text{ M}\Omega \pm 10\%$ resistance between the operator and ground.

Table 5-2 Static shielding protection levels

Static shielding protection levels	
Method	Voltage
Antistatic plastic	1,500
Carbon-loaded plastic	7,500
Metallized laminate	15,000

Grounding the work area

To prevent static damage at the work area, follow these precautions.

- Cover the work surface with approved static-dissipative material.
- Use a wrist strap connected to a properly grounded work surface and use properly grounded tools and equipment.
- Use static-dissipative mats, foot straps, or air ionizers to give added protection.
- Handle electrostatic sensitive components, parts, and assemblies by the case or PCB laminate. Handle them only at static-free work areas.
- Turn off power and input signals before inserting and removing connectors or test equipment.
- Use fixtures made of static-safe materials when fixtures must directly contact dissipative surfaces.
- Keep the work area free of nonconductive materials, such as ordinary plastic assembly aids and polystyrene foam.
- Use conductive field service tools, such as cutters, screwdrivers, and vacuums.
- Avoid contact with pins, leads, or circuitry.

Recommended materials and equipment

HP recommends certain materials and equipment to prevent static electricity.

- Antistatic tape
- Antistatic smocks, aprons, or sleeve protectors
- Conductive bins and other assembly or soldering aids
- Conductive foam
- Conductive tabletop workstations with ground cord of $1\text{ M}\Omega \pm 10\%$ resistance
- Static-dissipative table or floor mats with hard tie to ground
- Field service kits
- Static awareness labels
- Wrist straps and footwear straps providing $1\text{ M}\Omega \pm 10\%$ resistance

- Material handling packages
- Conductive plastic bags
- Conductive plastic tubes
- Conductive tote boxes
- Opaque shielding bags
- Transparent metallized shielding bags
- Transparent shielding tubes

6 Removal and replacement procedures for authorized service provider parts

This chapter provides removal and replacement procedures for authorized service provider parts.

 **IMPORTANT:** Components described in this chapter should be accessed only by an authorized service provider. Accessing these parts can damage the Chromebook or void the warranty.

 **NOTE:** Details about your Chromebook, including model, serial number, product key, and length of warranty, are on the service tag at the bottom of your Chromebook.

Component replacement procedures

To remove and replace Chromebook components, use these procedures.



NOTE: HP continually improves and changes product parts. For complete and current information about supported parts for your Chromebook, go to <http://partsurfer.hp.com>, select your country or region, and then follow the on-screen instructions.

You must remove, replace, or loosen as many as 30 screws when you service the parts described in this chapter. Make special note of each screw size and location during removal and replacement.

Preparation for disassembly

Bottom cover

To remove the bottom cover, use this procedure and illustration.

Table 6-1 Bottom cover description and part number

Description	Spare part number
Bottom cover	L17258-001

Before removing the bottom cover, prepare the Chromebox for disassembly ([Preparation for disassembly on page 27](#)).

Remove the bottom cover:

1. Position the Chromebox upside down with the rear toward you.
2. Remove the four rubber feet (1).

The rubber feet are available in the Rubber Feet Kit, spare part number L17271-001.

3. Remove the four Phillips M2.5 × 5.0 screws (2) that secure the bottom cover to the Chromebox.

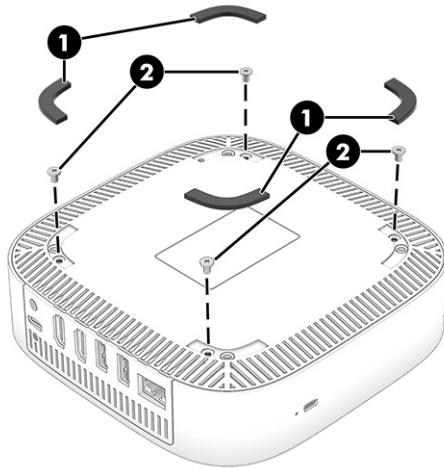

4. Use a case utility tool or similar thin plastic tool (1) to separate the front edge of the bottom cover (2) from the Chromebox.

5. Remove the bottom cover (3).

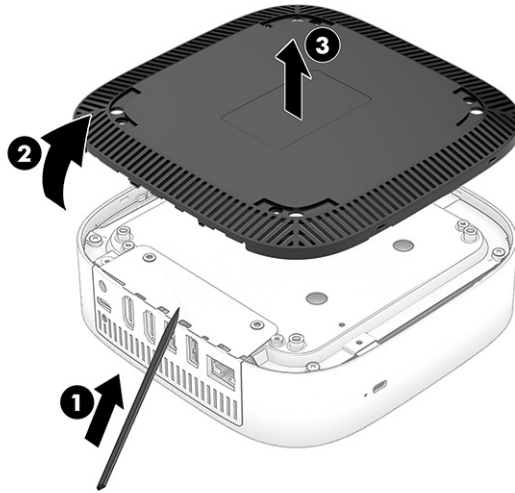

To replace the bottom cover, reverse the removal procedures.

I/O side frame

To remove the I/O side frame, use this procedure and illustration.

Table 6-2 I/O side frame description and part number

Description	Spare part number
I/O side frame	M24729-001

Before removing the I/O side frame, follow these steps:

1. Prepare the Chromebox for disassembly ([Preparation for disassembly on page 27](#)).
2. Remove the bottom cover ([Bottom cover on page 27](#)).

Remove the I/O side frame:

1. Remove the two Phillips M2.5 × 5.0 screws (1) that secure the I/O side frame to the Chromebox.
2. Detach the bottom shield rear protective strip (2) from the I/O side frame and bottom shield. (The bottom shield rear protective strip is attached to the I/O side frame and bottom shield with double-sided adhesive.)

The bottom shield rear protective strip is included in the Shield Kit, spare part number L20217-001.

3. Remove the I/O side frame (3) by swinging it up and out of the Chromebox.

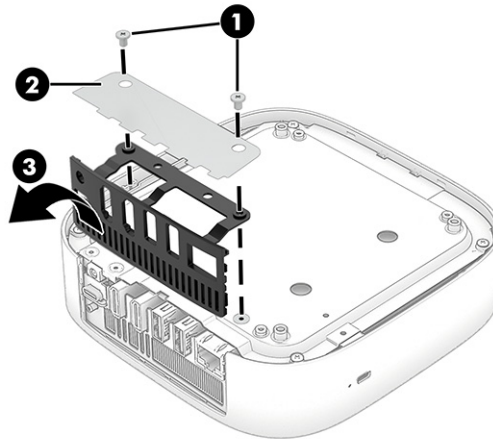

To replace the I/O side frame, reverse the removal procedures.

Bottom shield

To remove the bottom shield, use this procedure and illustration.

Table 6-3 Bottom shield description and part number

Description	Spare part number
Bottom shield	M41139-001

Before removing the bottom shield, follow these steps:

1. Prepare the Chromebox for disassembly ([Preparation for disassembly on page 27](#)).
2. Remove the bottom cover ([Bottom cover on page 27](#)).
3. Remove the I/O side frame ([I/O side frame on page 28](#)).

Remove the bottom shield:

1. Remove the four Phillips M2.5 × 5.0 screws (1) that secure the bottom shield to the Chromebox.
2. Detach the bottom shield front protective strip (2) and the bottom shield padding (3) from the bottom shield. (The bottom shield front protective strip is attached to the bottom shield with double-sided adhesive.)

The bottom shield front protective strip is included in the Shield Kit, spare part number L20217-001.

3. Release the bottom shield (4) as far as the power connector cable will allow.

4. Disconnect the power connector cable from the system board connector (5).

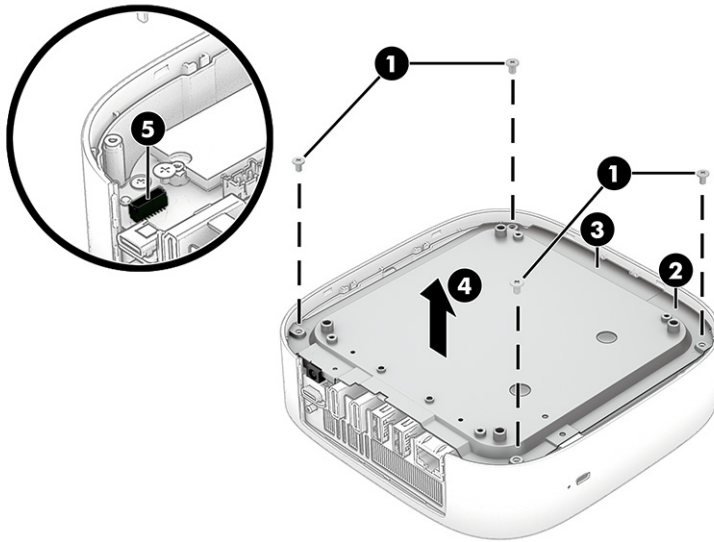

5. Remove the bottom shield.

To replace the bottom shield, reverse the removal procedures.

Power connector cable

To remove the power connector cable, use these procedures and illustrations.

Table 6-4 Power connector cable description and part number

Description	Spare part number
Power connector cable	L17259-001

Before removing the power connector cable, follow these steps:

1. Prepare the Chromebox for disassembly ([Preparation for disassembly on page 27](#)).
2. Remove the bottom cover ([Bottom cover on page 27](#)).
3. Remove the I/O side frame ([I/O side frame on page 28](#)).
4. Remove the bottom shield ([Bottom shield on page 29](#)).

Remove the power connector cable:

1. Turn the bottom shield right side up with the rear panel toward you.
2. Remove the two Phillips M2.5 × 5.0 screws (1) that secure the power connector cable to the bottom shield.
3. Remove the power connector cable bracket (2).
The power connector cable bracket is available using spare part number M42090-001.
4. Remove the power connector cable (3).

5. Inspect the power connector cable gasket (4). If the gasket needs to be replaced, it is available using spare part number L17265-001.

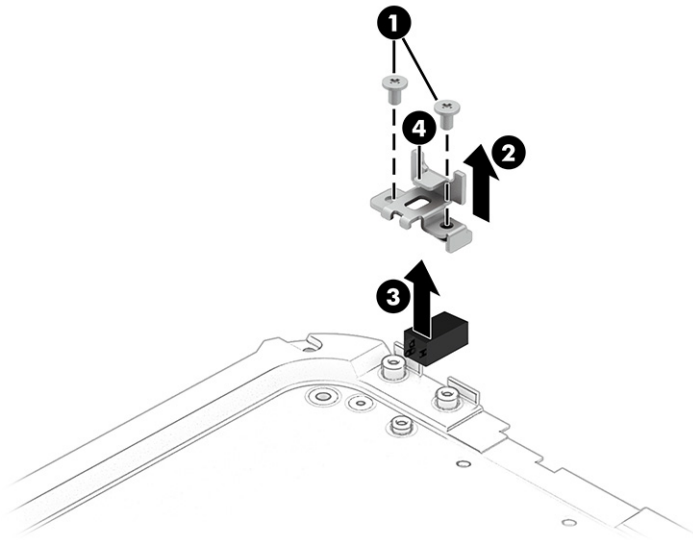

Reverse this procedure to install the power connector cable.

WLAN module

To remove the WLAN module, use this procedure and illustration.

Table 6-5 WLAN module description and part number

Description	Spare part number
Intel Wi-Fi 6 AX201 ax 2x2 + Bluetooth 5 MU-MIMO M.2 2230 non-vPro MIPI+BRI WW with 2 antennas WLAN module	L57250-005

IMPORTANT: To prevent an unresponsive system, replace the wireless module only with a wireless module authorized for use in the Chromebook by the governmental agency that regulates wireless devices in your country or region. If you replace the module and then receive a warning message, remove the module to restore device functionality, and then contact technical support.

Before removing the WLAN module, follow these steps:

1. Prepare the Chromebox for disassembly ([Preparation for disassembly on page 27](#)).
2. Remove the bottom cover ([Bottom cover on page 27](#)).
3. Remove the I/O side frame ([I/O side frame on page 28](#)).
4. Remove the bottom shield ([Bottom shield on page 29](#)).

Remove the WLAN module:

1. Disconnect the WLAN antenna cables (1) from the WLAN module terminals.

 **NOTE:** The #1/Main WLAN antenna cable connects to the WLAN module **#1/Main** terminal. The #2/Aux WLAN antenna cable connects to the WLAN module **#2/Aux** terminal.

2. Remove the Phillips M2.0 × 2.9 screw (2) that secures the WLAN module to the system board. (The WLAN module tilts up.)
3. Remove the WLAN module (3) by pulling the module away from the slot at an angle.

 **NOTE:** WLAN modules are notched to prevent incorrect installation.

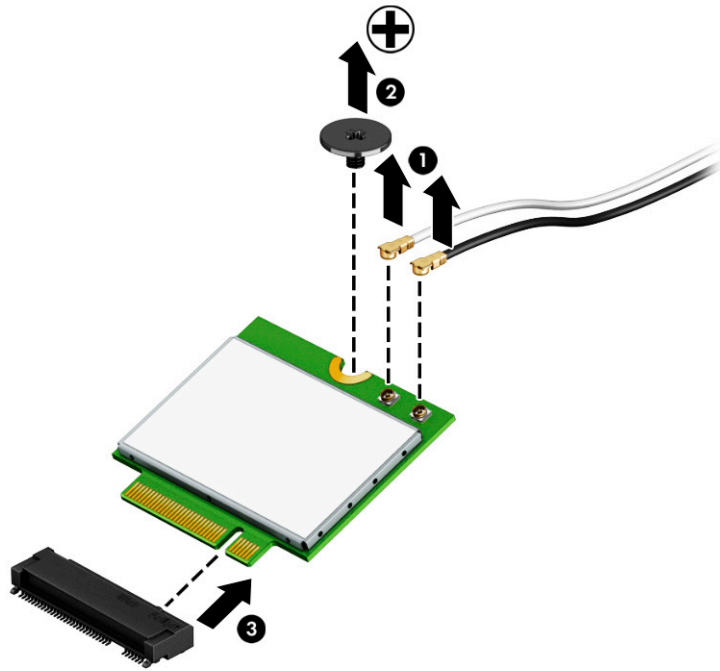

4. If the WLAN antenna is not connected to the terminal on the WLAN module, install a protective sleeve on the antenna connector, as shown in the following illustration.

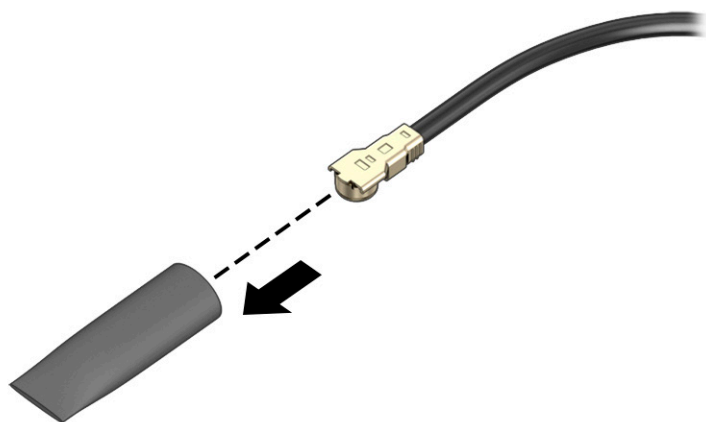

Reverse this procedure to install the WLAN module.

Solid-state drive

To remove the solid-state drive, use this procedure and illustration.

Table 6-6 Solid-state drive description and part number

Description	Spare part number
128 GB, 2230, PCIe, NVMe, value solid-state drive	M11040-005
Solid-state drive absorber	M24278-001

Before removing the solid-state drive, follow these steps:

1. Prepare the Chromebox for disassembly ([Preparation for disassembly on page 27](#)).
2. Remove the bottom cover ([Bottom cover on page 27](#)).
3. Remove the I/O side frame ([I/O side frame on page 28](#)).
4. Remove the bottom shield ([Bottom shield on page 29](#)).

Remove the solid-state drive:

1. Remove the Phillips M2.0 × 2.9 screw **(1)** that secures the solid-state drive to the system board.
2. Remove the solid-state drive **(2)** by sliding it away from the slot at an angle.

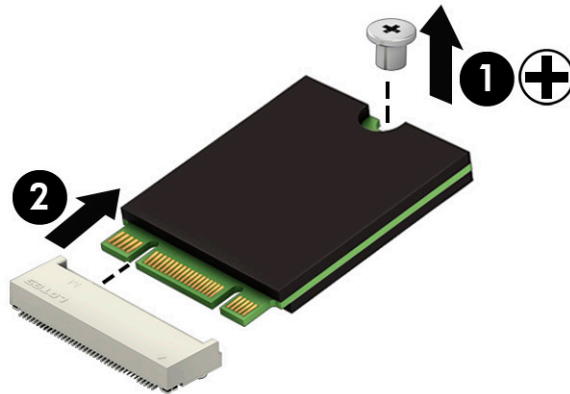

Reverse this procedure to install the solid-state drive.

Memory module

To remove the memory module, use this procedure and illustration.

Table 6-7 Memory module description and part numbers

Description	Spare part number
8 GB (DDR4, 3200 GHz, 1.2 V)	L46598-005
4 GB (DDR4, 3200 GHz, 1.2 V)	L83673-005

Before removing the memory module, follow these steps:

1. Prepare the Chromebox for disassembly ([Preparation for disassembly on page 27](#)).
2. Remove the bottom cover ([Bottom cover on page 27](#)).
3. Remove the I/O side frame ([I/O side frame on page 28](#)).
4. Remove the bottom shield ([Bottom shield on page 29](#)).

Remove the memory module:

1. Insert a case utility tool or similar thin, plastic tool into the openings **(1)** on either side of the memory module shield and remove the shield **(2)**. The memory module shield is available using spare part number L17264-001.

 **NOTE:** When installing the memory module shield, be sure that the edges of the shield fit securely into the retention clips **(3)** built into the system board.

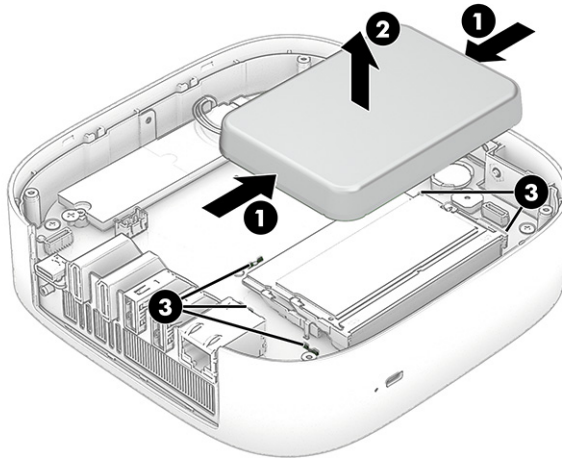

- Spread the two retention clips outward (1) until the memory module tilts up at a 45° angle, and then remove the module (2). Use the same procedure to remove all memory modules.

 **IMPORTANT:** To prevent damage to the memory module, hold the memory module by the edges only. Do not touch the components on the memory module. Place it in an electrostatic-safe container.

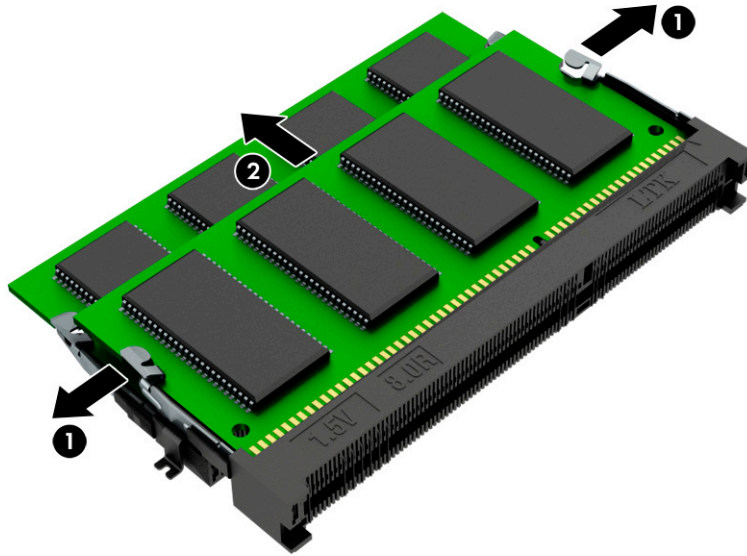

Reverse this procedure to install a memory module.

System board

To remove the system board, use these procedures and illustrations.

Table 6-8 System board descriptions and part numbers

Description	Spare part number
The system board spare part kit includes the processor, RTC battery, replacement thermal material, a graphics subsystem with UMA memory, and the Chrome operating system.	
Equipped with an Intel Core i7-10610U processor	M24721-001
Equipped with an Intel Core i5-10310U processor and 64 GB on-board system memory	M25770-001
Equipped with an Intel Core i5-10310U processor	M24720-001
Equipped with an Intel Core i3-10110U processor and 64 GB on-board system memory	M25769-001
Equipped with an Intel Core i3-10110U processor	M24719-001
Equipped with an Intel Pentium 6405U processor and 64 GB on-board system memory	M25771-001
Equipped with an Intel Pentium 6405U processor and 32 GB on-board system memory	M24722-001
Equipped with an Intel Celeron 5205U processor and 64 GB on-board system memory	M25768-001
Equipped with an Intel Celeron 5205U processor and 32 GB on-board system memory	M24718-001

Before removing the system board, follow these steps:

1. Prepare the Chromebox for disassembly ([Preparation for disassembly on page 27](#)).
2. Remove the bottom cover ([Bottom cover on page 27](#)).
3. Remove the I/O side frame ([I/O side frame on page 28](#)).
4. Remove the bottom shield ([Bottom shield on page 29](#)).

When you replace the system board, be sure to remove the following components from the defective system board and install them on the replacement system board:

- WLAN module (see [WLAN module on page 31](#))
- Solid-state drive (see [Solid-state drive on page 33](#))
- Memory module and shield (see [Memory module on page 33](#))
- Fan (see [Fan on page 37](#))
- Heat sink (see [Heat sink on page 38](#))

Remove the system board:

1. Disconnect the WLAN antenna cables (**1**) from the WLAN module terminals.

 **NOTE:** The #1/Main WLAN antenna cable connects to the WLAN module **#1/Main** terminal. The #2/Aux WLAN antenna cable connects to the WLAN module **#2/Aux** terminal.

2. Disconnect the power button board cable (**2**) from the system board.

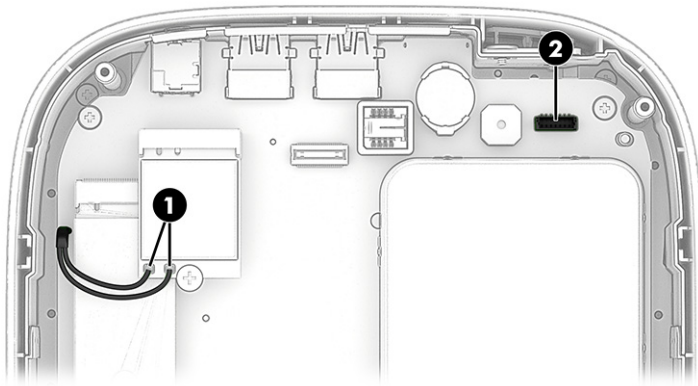

3. Remove the four Phillips M2.5 × 5.0 screws that secure the system board to the top cover.

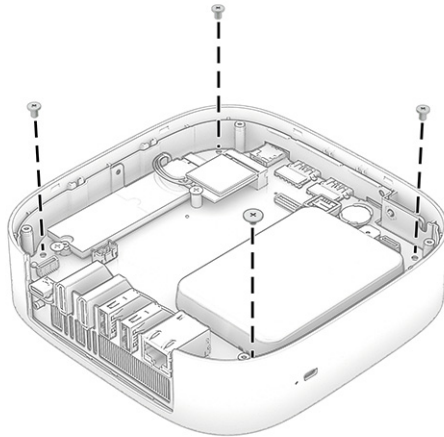

4. Lift the rear edge of the system board (1) until it rests at an angle.
5. Remove the system board (2) by sliding it forward at an angle.

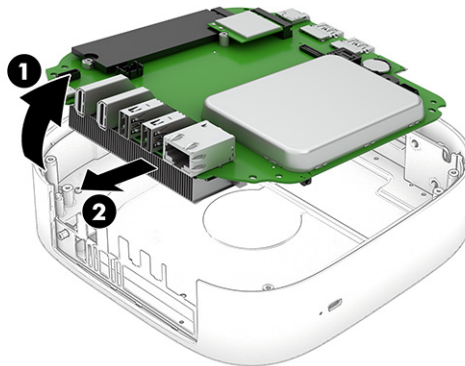

Reverse this procedure to install the system board.

Fan

To remove the fan, use these procedures and illustrations.

Table 6-9 Fan description and part number

Description	Spare part number
Fan (includes cable)	M24727-001

Before removing the fan, follow these steps:

1. Prepare the Chromebox for disassembly ([Preparation for disassembly on page 27](#)).
2. Remove the bottom cover ([Bottom cover on page 27](#)), and then remove the following components:

1. Remove the I/O side frame ([I/O side frame on page 28](#)).
2. Remove the bottom shield ([Bottom shield on page 29](#)).
3. Remove the system board ([System board on page 35](#)).

Remove the fan:

1. Turn the system board right side up with the front toward you.
2. Disconnect the fan cable (1) from the system board.
3. Remove the two Phillips M2.0 × 4.0 screws (2) that secure the fan to the system board.
4. Remove the fan (3).

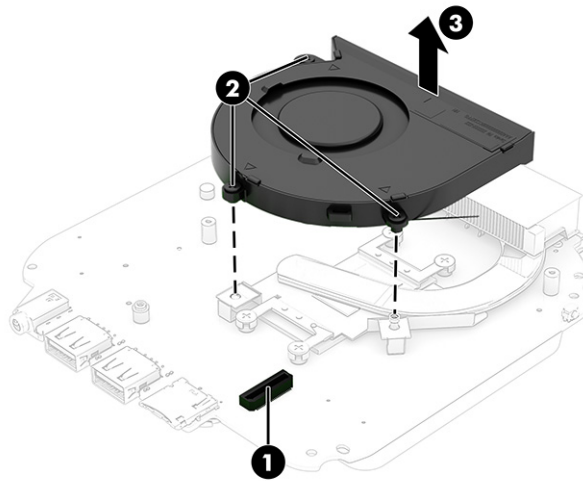

Reverse this procedure to install the fan.

Heat sink

To remove the heat sink, use these procedures and illustrations.

Table 6-10 Heat sink description and part number

Description	Spare part number
Heat sink (15 W, includes replacement thermal material)	M24726-001

Before removing the heat sink, follow these steps:

1. Prepare the Chromebox for disassembly ([Preparation for disassembly on page 27](#)).
2. Remove the bottom cover ([Bottom cover on page 27](#)), and then remove the following components:
 1. Remove the I/O side frame ([I/O side frame on page 28](#)).
 2. Remove the bottom shield ([Bottom shield on page 29](#)).
 3. Remove the system board ([System board on page 35](#)).
 4. Remove the fan ([Fan on page 37](#)).

Remove the heat sink:

1. Remove the four Phillips M2.0 × 4.0 screws (1) that secure the heat sink to the system board.
2. Remove the heat sink (2).

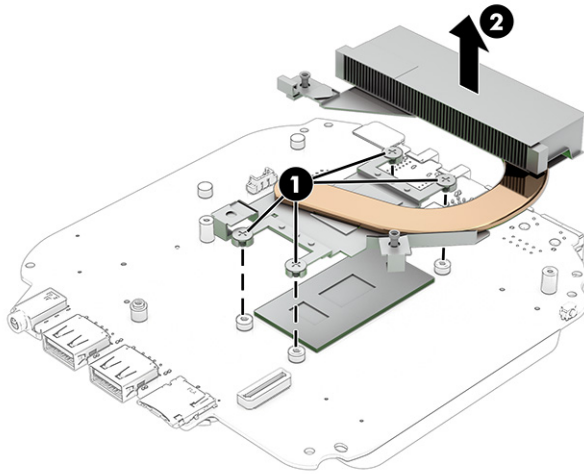

Each time the heat sink is removed, thoroughly clean the thermal material from the processor component (1) and the surface of the heat sink (2). Replacement thermal material is included with the heat sink and system board spare part kits.

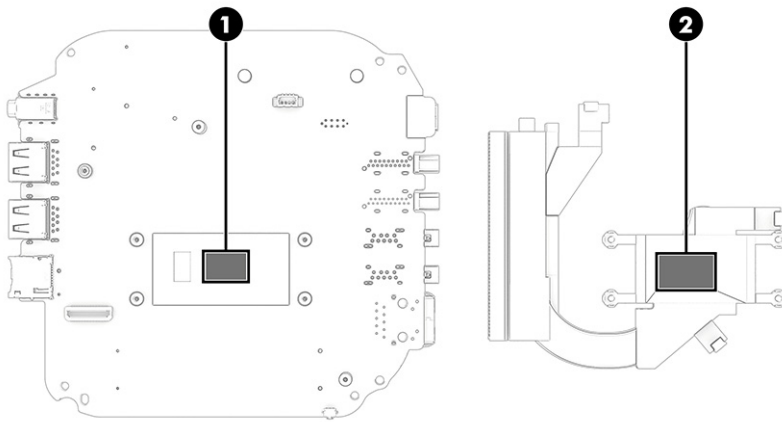

Reverse this procedure to install the heat sink.

Top shield

To remove the top shield, use this procedure and illustration.

Table 6-11 Top shield description and part number

Description	Spare part number
Top shield (includes wireless antenna)	M24725-001

1. Prepare the Chromebox for disassembly ([Preparation for disassembly on page 27](#)).
2. Remove the bottom cover ([Bottom cover on page 27](#)), and then remove the following components:
 1. Remove the I/O side frame ([I/O side frame on page 28](#)).
 2. Remove the bottom shield ([Bottom shield on page 29](#)).
 3. Remove the system board ([System board on page 35](#)).

Remove the top shield:

1. Remove the four Phillips M2.5 × 5.0 screws (1) that secure the top shield to the top cover.
2. Lift the rear edge of the top shield (2) until it rests at an angle.
3. Remove the top shield (3).

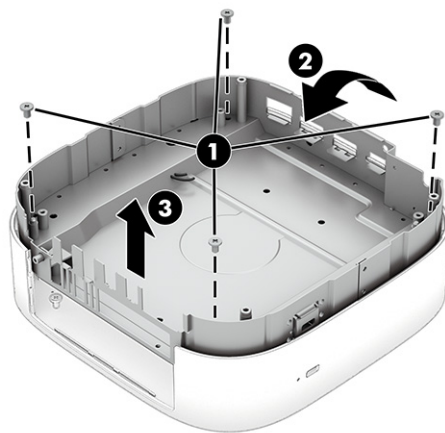

Reverse this procedure to install the top shield.

Power button board

To remove the power button board, use these procedures and illustrations.

Table 6-12 Power button board description and part number

Description	Spare part number
Power button board	M24724-001

Before removing the power button board, follow these steps:

1. Prepare the Chromebox for disassembly ([Preparation for disassembly on page 27](#)).
2. Remove the bottom cover ([Bottom cover on page 27](#)), and then remove the following components:
 1. Remove the I/O side frame ([I/O side frame on page 28](#)).
 2. Remove the bottom shield ([Bottom shield on page 29](#)).
 3. Remove the system board ([System board on page 35](#)).
 4. Remove the top shield ([Top shield on page 39](#)).

Remove the power button board:

1. Remove the two Phillips M2.0 × 3.0 broad head screws (1) that secure the power button board to the top shield.
2. Remove the power button board (2).
3. If it is necessary to replace the power button board cable, disconnect the cable from the connector (3) on the power button board. The power button board cable is available using spare part number M42089-001.

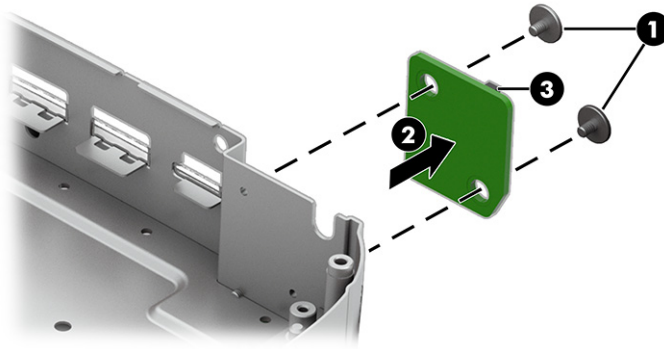

Reverse this procedure to install the power button board.

7 Specifications

This chapter provides specifications for your Chromebox.

Chromebook specifications

This section provides specifications for your Chromebook. When traveling with your Chromebook, the Chromebook dimensions and weights, as well as input power ratings and operating specifications, provide helpful information.

Table 7-1 Chromebook specifications

	Metric	U.S.
Dimensions		
Width	14.9 cm	5.9 in
Depth	14.9 cm	5.9 in
Height (front to back)	4.0 cm	1.6 in
Weight (varies by Chromebook configuration and components)	0.6 g	1.4 lb
Input power		

Table 7-1 Chromebook specifications (continued)

	Metric	U.S.
Operating voltage and current	5 V dc @ 2 A / 12 V dc @ 3 A / 15 V dc @ 3 A – 45 W USB-C®	
	5 V dc @ 3 A / 9 V dc @ 3 A / 12 V dc @ 3.75 A / 15 V dc @ 3 A – 45 W USB-C	
	5 V dc @ 3 A / 9 V dc @ 3 A / 10 V dc @ 3.75 A / 12 V dc @ 3.75 A / 15 V dc @ 3 A / 20 V dc @ 2.25 A – 45 W USB-C	
	5 V dc @ 3 A / 9 V dc @ 3 A / 12 V dc @ 5 A / 15 V dc @ 4.33 A / 20 V dc @ 3.25 A – 65 W USB-C	
	5 V dc @ 3 A / 9 V dc @ 3 A / 10 V dc @ 5 A / 12 V dc @ 5 A / 15 V dc @ 4.33 A / 20 V dc @ 3.25 A – 65 W USB-C	
	5 V dc @ 3 A / 9 V dc @ 3 A / 10 V dc @ 5 A / 12 V dc @ 5 A / 15 V dc @ 5 A / 20 V dc @ 4.5 A – 90 W USB-C	
	19.5 V dc @ 2.31 A – 45 W	
	19.5 V dc @ 3.33 A – 65 W	
	19.5 V dc @ 4.62 A – 90 W	
	19.5 V dc @ 6.15 A – 120 W	
	19.5 V dc @ 6.9 A – 135 W	
	19.5 V dc @ 7.70 A – 150 W	
	19.5 V dc @ 10.3 A – 200 W	
	19.5 V dc @ 11.8 A – 230 W	
19.5 V dc @ 16.92 A – 330 W		
19.5 V dc @ 3.33 A – 65 W		
19.5 V dc @ 4.62 A – 90 W		
19.5 V dc @ 7.70 A – 150 W		
19.5 V dc @ 10.3 A – 200 W		
Temperature		
Operating	5°C to 35°C	41°F to 95°F
Nonoperating	–20°C to 60°C	–4°F to 140°F
Relative humidity (noncondensing)		
Operating	10% to 90%	
Nonoperating	5% to 95%	
Maximum altitude (unpressurized)		
Operating	–15 m to 3,048 m	–50 ft to 10,000 ft
Nonoperating	–15 m to 12,192 m	–50 ft to 40,000 ft
NOTE: Applicable product safety standards specify thermal limits for plastic surfaces. The device operates well within this range of temperatures.		

Solid-state drive specifications

This section provides specifications for your solid-state drives.

Table 7-2 Solid-state drive specifications

128 GB*	
Dimensions	
Height	1.0 mm
Length	50.8 mm
Width	28.9 mm
Weight	< 10 g
Interface type	PCIe
Ready time, maximum (to not busy)	1.0 ms
Access times, logical	0.1 ms
Transfer rate	
Sequential read	up to 2150 MB/s
Random read	Up to 300,000 IOPs
Sequential write	up to 1550 MB/s
Random write	Up to 100,000 IOPs
Total logical sectors	227,513,216
Operating temperature	0°C to 70°C (32°F to 158°F)
*1 GB = 1 billion bytes when referring to hard drive storage capacity. Actual accessible capacity is less. Actual drive specifications may differ slightly.	
NOTE: Certain restrictions and exclusions apply. Contact support for details.	

8 Power cord set requirements

This chapter provides power cord requirements for countries and regions.

The wide-range input feature of the Chromebox permits it to operate from any line voltage from 100 V ac to 120 V ac, or from 220 V ac to 240 V ac.

The 3-conductor power cord set included with the Chromebox meets the requirements for use in the country or region where the equipment is purchased.

Power cord sets for use in other countries or regions must meet the requirements of the country and region where the Chromebox is used.

Requirements for all countries

These power cord requirements are applicable to all countries and regions.

- The length of the power cord set must be at least **1.0 m** (3.3 ft) and no more than **2.0 m** (6.5 ft).
- All power cord sets must be approved by an acceptable accredited agency responsible for evaluation in the country or region where the power cord set will be used.
- The power cord sets must have a minimum current capacity of 10 A and a nominal voltage rating of 125 V ac or 250 V ac, as required by the power system of each country or region.
- The appliance coupler must meet the mechanical configuration of an EN 60 320/IEC 320 Standard Sheet C13 connector for mating with the appliance inlet on the back of the computer.

Requirements for specific countries and regions

To determine power cord requirements for specific countries and regions, use this table.

Table 8-1 Power cord requirements for specific countries and regions

Country/region	Accredited agency	Applicable note number
Argentina	IRAM	1
Australia	SAA	1
Austria	OVE	1
Belgium	CEBEC	1
Brazil	ABNT	1
Canada	CSA	2

Table 8-1 Power cord requirements for specific countries and regions (continued)

Country/region	Accredited agency	Applicable note number
Chile	IMQ	1
Denmark	DEMKO	1
Finland	FIMKO	1
France	UTE	1
Germany	VDE	1
India	BIS	1
Israel	SII	1
Italy	IMQ	1
Japan	JIS	3
Netherlands	KEMA	1
New Zealand	SANZ	1
Norway	NEMKO	1
People's Republic of China	CCC	4
Saudi Arabia	SASO	7
Singapore	PSB	1
South Africa	SABS	1
South Korea	KTL	5
Sweden	SEMKO	1
Switzerland	SEV	1
Taiwan	BSMI	6
Thailand	TISI	1
United Kingdom	ASTA	1

Table 8-1 Power cord requirements for specific countries and regions (continued)

Country/region	Accredited agency	Applicable note number
United States	UL	2
<ol style="list-style-type: none">1. The flexible cord must be Type H05VV-F, 3-conductor, 0.75 mm² conductor size. Power cord set fittings (appliance coupler and wall plug) must bear the certification mark of the agency responsible for evaluation in the country or region where it will be used.2. The flexible cord must be Type SVT/SJT or equivalent, No. 18 AWG, 3-conductor. The wall plug must be a two-pole grounding type with a NEMA 5-15P (15 A, 125 V ac) or NEMA 6-15P (15 A, 250 V ac) configuration. CSA or C-UL mark. UL file number must be on each element.3. The appliance coupler, flexible cord, and wall plug must bear a T mark and registration number in accordance with the Japanese Dentori Law. The flexible cord must be Type VCTF, 3-conductor, 0.75 mm² or 1.25 mm² conductor size. The wall plug must be a two-pole grounding type with a Japanese Industrial Standard C8303 (7 A, 125 V ac) configuration.4. The flexible cord must be Type RVV, 3-conductor, 0.75 mm² conductor size. Power cord set fittings (appliance coupler and wall plug) must bear the CCC certification mark.5. The flexible cord must be Type H05VV-F 3-conductor, 0.75 mm² conductor size. KTL logo and individual approval number must be on each element. Approval number and logo must be printed on a flag label.6. The flexible cord must be Type HVCTF 3-conductor, 1.25 mm² conductor size. Power cord set fittings (appliance coupler, cable, and wall plug) must bear the BSMI certification mark.7. For 127 V ac, the flexible cord must be Type SVT or SJT 3-conductor, 18 AWG, with plug NEMA 5-15P (15 A, 125 V ac), with UL and CSA or C-UL marks. For 240 V ac, the flexible cord must be Type H05VV-F 3-conductor, 0.75 mm² or 1.00 mm² conductor size, with plug BS 1363/A with BSI or ASTA marks.		

9 Recycling

When a nonrechargeable or rechargeable battery has reached the end of its useful life, do not dispose of the battery in general household waste. Follow the local laws and regulations in your area for battery disposal.

HP encourages customers to recycle used electronic hardware, HP original print cartridges, and rechargeable batteries. For more information about recycling programs, see the HP website at <http://www.hp.com/recycle>.

Index

B

- Bluetooth label 9
- bottom cover
 - removal 27
 - spare part number 27
- bottom shield
 - removal 29
 - spare part number 29

C

- cautions
 - electrostatic discharge 17, 21
- Chromebook specifications 43
- Chromebox major components 13
- Chromebox specifications 43
- components
 - bottom 8
 - front side 6
 - rear side 7
 - right side 5

D

- display
 - specifications 43

E

- electrostatic discharge (ESD) 17, 21
 - preventing damage 17, 21, 22

F

- fan
 - removal 37
 - spare part number 37
- feet
 - removal 27

G

- grounding methods 17, 21, 22
- guidelines
 - packaging 17

- transporting 17
- workstation 17, 18

H

- hard drive
 - specifications 43
- heat sink
 - removal 38
 - spare part number 38

I

- I/O side frame
 - removal 28
 - spare part number 28
- illustrated parts catalog 13

K

- keyboard
 - product description 2

L

- labels
 - Bluetooth 9
 - regulatory 9
 - serial number 9
 - service 9
 - wireless certification 9
 - WLAN 9

M

- memory module
 - removal 33
 - spare part numbers 33
- memory module shield
 - removal 34
 - spare part number 34

P

- packaging guidelines 17

- pointing device, product description 2

- power button board
 - removal 40
 - spare part number 40
- power button board cable
 - removal 41
 - spare part number 41
- power connector cable
 - removal 30
 - spare part number 30
- power connector cable bracket
 - removal 30
 - spare part number 30
- power connector cable gasket
 - removal 31
- power cord
 - requirements for all countries 47
 - requirements for specific countries and regions 47
 - set requirements 47
- product description
 - keyboard 2
 - pointing device 2
- product name and number, Chromebox 9

R

- regulatory information
 - regulatory label 9
 - wireless certification labels 9
- removal and replacement
 - procedures 26
- rubber feet
 - removal 27

S

- serial number, Chromebox 9
- service labels, locating 9

- solid-state drive
 - removal 33
 - spare part number 33
 - specifications 45
- specifications
 - Chromebook 43
 - Chromebox 43
 - display 43
 - hard drive 43
 - solid-state drive 45
- static electricity 17, 21
- system board
 - removal 35
 - spare part numbers 35

T

- top shield
 - removal 39
 - spare part number 39
- transporting guidelines 17
- traveling with the Chromebox 9

W

- wireless certification label 9
- WLAN device 9
- WLAN label 9
- WLAN module
 - removal 31
 - spare part number 31
- workstation guidelines 17, 18