

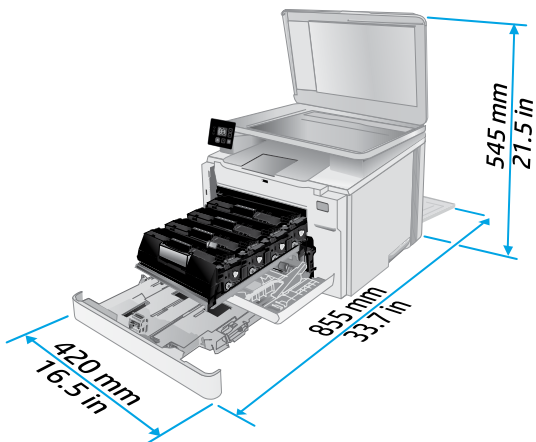

# Color LaserJet Pro MFP M182-M185

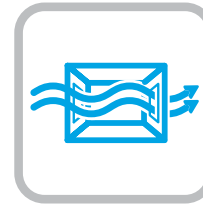

M182n  
M182nw

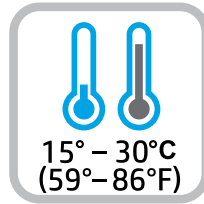
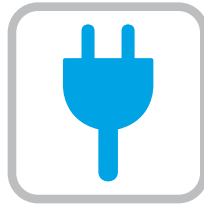
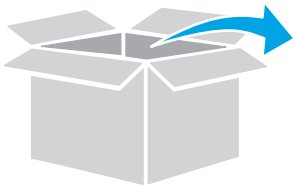
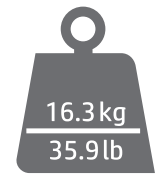
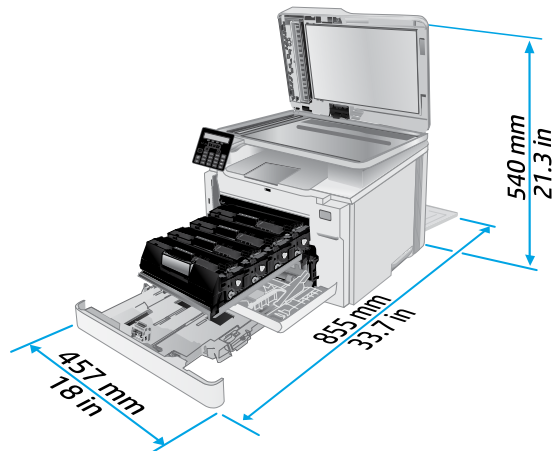

M183fw

1

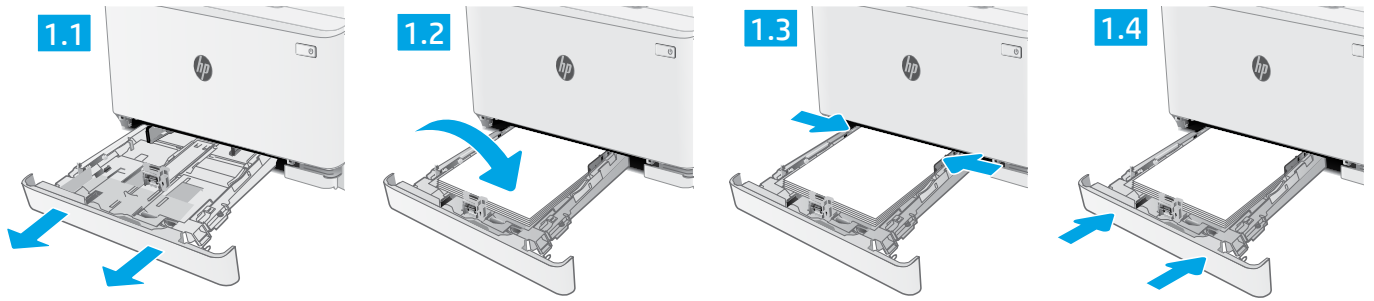

2

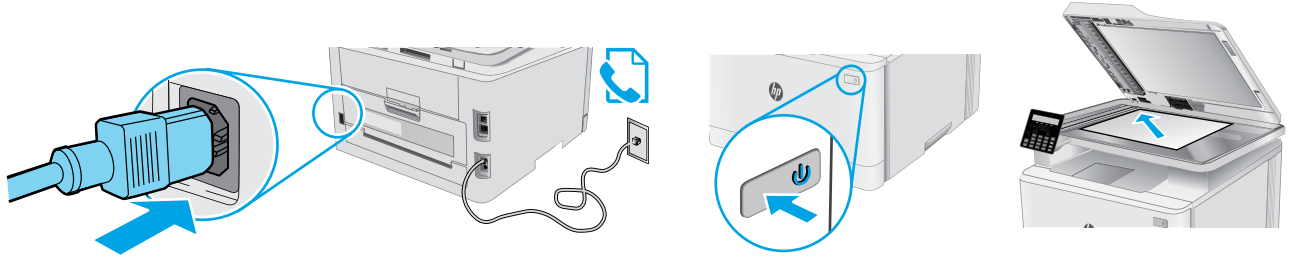

3

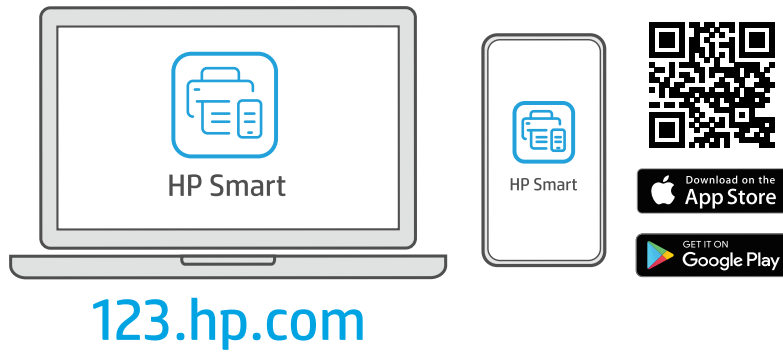

?

[hp.com/support/printer-setup](http://hp.com/support/printer-setup)



**EN** **Trouble getting started?**  
Find setup information and videos online.

**ID** **Mengalami masalah saat memulai?**  
Temukan informasi penyiapan dan video secara online.

**KO** **시작하는 데 문제가 있으십니까?**  
설정 정보 및 동영상을 온라인에서 찾아보십시오.

**TH** **ประสบปัญหาในการเริ่มต้นใช้งานใช่ไหม**  
ค้นหาข้อมูลและวิดีโอเกี่ยวกับการตั้งค่าผ่านทางออนไลน์

**ZHTW** **開始使用時遇到問題?**  
在線上尋找設定資訊及視訊。

**VI** **Bạn gặp vấn đề khi bắt đầu?**  
Tìm thông tin cài đặt và video trực tuyến.



# Color LaserJet Pro MFP M182-M185 Reference Guide

English.....3

Bahasa Indonesia.....6

한국어.....9

ไทย.....12

繁體中文.....15

Tiếng Việt.....18

## Need Help? - FAQ

For frequently asked questions, go to [www.hp.com/support/ljM182MFPFAQ](http://www.hp.com/support/ljM182MFPFAQ) or scan the QR code.



## LED control panel view

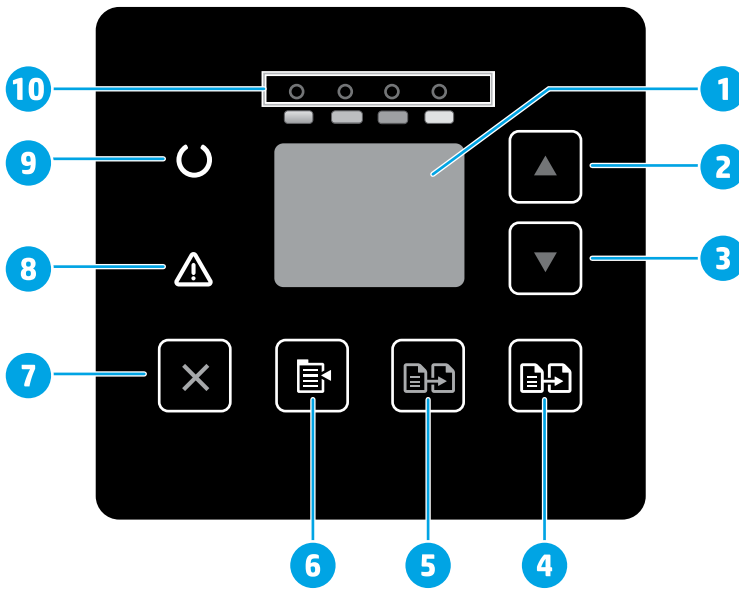



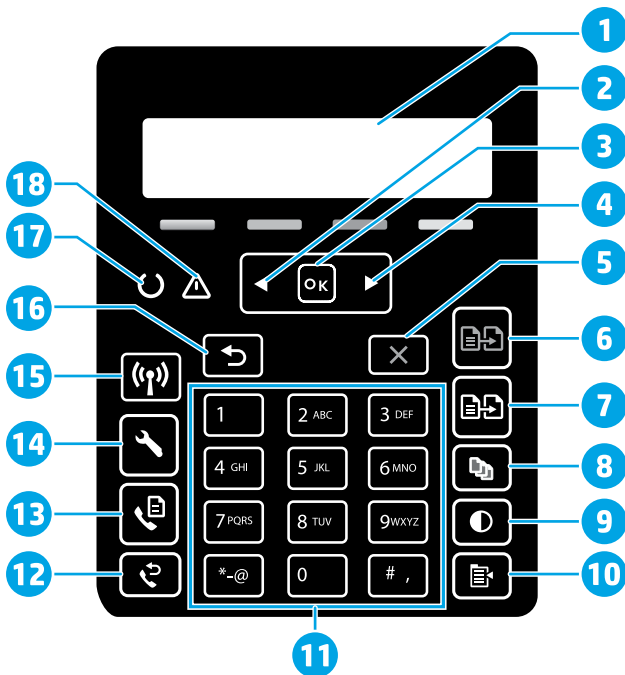

- |    |                              |
|----|------------------------------|
| 1  | Control panel LED display    |
| 2  | Up arrow ▲ button            |
| 3  | Down arrow ▼ button          |
| 4  | Start Color Copy / OK button |
| 5  | Start Mono Copy button       |
| 6  | Copy Setup button            |
| 7  | Cancel X button              |
| 8  | Attention Δ LED              |
| 9  | Ready ○ LED                  |
| 10 | Supplies LEDs                |

## 2-line LCD control panel view



- |   |                              |    |                                       |
|---|------------------------------|----|---------------------------------------|
| 1 | 2-line control panel display | 10 | Copy Menu button                      |
| 2 | Left arrow ◀ button          | 11 | Alphanumeric keypad                   |
| 3 | OK button                    | 12 | Fax Redial button (fax models only)   |
| 4 | Right arrow ▶ button         | 13 | Start Fax button (fax models only)    |
| 5 | Cancel X button              | 14 | Setup button                          |
| 6 | Start Mono Copy button       | 15 | Wireless button (wireless model only) |
| 7 | Start Color Copy button      | 16 | Back arrow button                     |
| 8 | Number of Copies button      | 17 | Ready LED                             |
| 9 | Lighter/Darker button        | 18 | Attention Δ LED                       |

## Control panel light patterns

Lights	Description	Solution
	Ready	No action to take.
	Toner cartridge is at end of life	A Supplies light blinks when a supply error occurs, and it glows without blinking when the supply is very low.
	Fatal error	Power cycle. If error still appears, call HP customer service.
	Processing	No action to take.
	Error/Manual Feed/Manual Duplex/Out of paper/Door open/Jam	<ul style="list-style-type: none"> <li>Manual Feed/Manual Duplex - Press the <b>OK</b> button when ready.</li> <li>Out of paper - Insert paper.</li> <li>Door open - Secure all doors.</li> <li>Error/Jam - Refer to User Guide.</li> </ul>

## Control panel error message

Error Message	Solution
Load Paper	Insert paper.
<ul style="list-style-type: none"> <li>Initializing...</li> <li>Cleaning...</li> <li>Printing... Cool down mode</li> </ul>	No action to take.
Door is open	Secure all doors.
<ul style="list-style-type: none"> <li>Jam in tray 1. Clear jam and then press <b>OK</b>.</li> <li>Jam in cartridge area. Open top cover and remove cartridge. Clear jam.</li> </ul>	Refer to User Guide.
<ul style="list-style-type: none"> <li>Manual Feed. Plain, Letter. Or press <b>OK</b> to use available media.</li> <li>Manual Duplex. Load tray 1. Press <b>OK</b> to continue.</li> </ul>	Press the <b>OK</b> button when ready.
<ul style="list-style-type: none"> <li>Supply problem.</li> <li>Install cartridge.</li> <li>Incompatible cartridge.</li> <li>Protected cartridge.</li> <li>Unauthorized cartridge.</li> </ul>	Take out and reinsert the toner cartridge. If error still appears, go to <a href="http://www.hp.com/support/ljM182MFP">www.hp.com/support/ljM182MFP</a> .
<ul style="list-style-type: none"> <li>Cartridge is very low.</li> <li>Used or counterfeit cartridge in use.</li> </ul>	Replace with a new cartridge.

## Download and install the software

**NOTE:** Do not connect the USB cable until you are prompted to do so.

### Method 1: Download from [123.hp.com/laserjet](http://123.hp.com/laserjet)

- Go to [123.hp.com/laserjet](http://123.hp.com/laserjet) (Windows) or [123.hp.com](http://123.hp.com) (OS X), and click **Download**.
- Follow the onscreen instructions and then prompts to save the file to the computer.
- Launch the software file from the folder where the file was saved.
- Follow the onscreen instructions to install the software.
- When prompted to select a connection type, select the appropriate option for the type of connection.

### Method 2: Download from printer support website (Windows)

- Go to [www.hp.com/support/ljM182MFP](http://www.hp.com/support/ljM182MFP).
- Select **Software and Drivers**.
- Download the software for your printer model and operating system.
- Launch the software file from the folder where the file was saved.
- Follow the onscreen instructions to install the software.
- When prompted to select a connection type, select the appropriate option for the type of connection.

## Method 1: HP Smart

Use the HP Smart app to set up, print, and more.

1. Scan the QR code or go to [123.hp.com](http://123.hp.com).
2. Install the HP Smart app.
3. Run the HP Smart app and follow the onscreen instructions to connect, set up, print, and more.



## Method 2: Wi-Fi Direct (wireless models only)

Wi-Fi Direct allows Wi-Fi capable devices, such as smart phones, tablets, or computers, to make a wireless network connection directly to the printer without using a wireless router or access point. Connect to the printer's Wi-Fi Direct signal the same way Wi-Fi capable devices are connected to a new wireless network or hotspot.

### Enable Wi-Fi Direct

To set up Wi-Fi Direct from the control panel, complete the following steps:

1. On the printer control panel, press the Setup  button, and then open the Network Setup menu.
2. Open the following menus:
  - **Wi-Fi Direct**
  - **On/Off**
3. Touch the **On** menu item.

### Discover the printer

1. From the mobile device, turn on the Wi-Fi, and search for wireless networks.
2. Select the printer as shown on the printer control panel.

**Example printer name:** Direct-bb-HP M182 Laserjet

### Learn more about mobile printing

For further information about these and other operating systems (Chrome/Google Cloud Print), go to [www.hp.com/go/LaserJetMobilePrinting](http://www.hp.com/go/LaserJetMobilePrinting) or scan the QR code.



## Use the scan feature

Use the HP Scan software on your computer to start a scan job at the printer.

### Windows

Click **Start**, select **Programs** or **All Programs**, select **HP**, and then select **HP Scan**.

### OS X





Go to the **Applications** folder and open **HP Smart**.

## Troubleshooting

### Wireless connection troubleshooting

Verify that the printer is within the range of the wireless network. For most networks, the printer must be within 30 m (100 ft) of the wireless access point (wireless router). A USB cable might be required for temporary connection between the printer and the computer. To ensure that the wireless setup information synchronizes correctly, do not connect the USB cable until prompted to do so.

#### Follow these steps to restore the network settings:

1. Remove the USB cable from the printer.
2. Press and hold the Wireless  button on the printer control panel. When the Ready  LED and the Attention  LED start blinking simultaneously, release the Wireless  button. Printer will restore network default automatically and restart.
3. When the Ready  LED is on, continue to install the software.

### User guide and additional support resources

The user guide includes printer usage and troubleshooting information. It is available on the web: Go to [www.hp.com/support/ljM182MFP](http://www.hp.com/support/ljM182MFP).

#### Check for firmware updates

1. Go to [www.hp.com/support/ljM182MFP](http://www.hp.com/support/ljM182MFP).
2. Select a printer or category from the list, and then click **Drivers**.
3. Select the operating system, and click the **Next** button.
4. Select **Firmware**, and click the **Download** button.

### Wireless printing

For more information about wireless printing and wireless setup, go to [www.hp.com/go/wirelessprinting](http://www.hp.com/go/wirelessprinting).





# Color LaserJet Pro MFP M182-M185

## Panduan Referensi

### Butuh Bantuan? - FAQ

Untuk pertanyaan umum, kunjungi [www.hp.com/support/lj182MFPFAQ](http://www.hp.com/support/lj182MFPFAQ) atau pindai kode QR.



### Tampilan panel kontrol LED

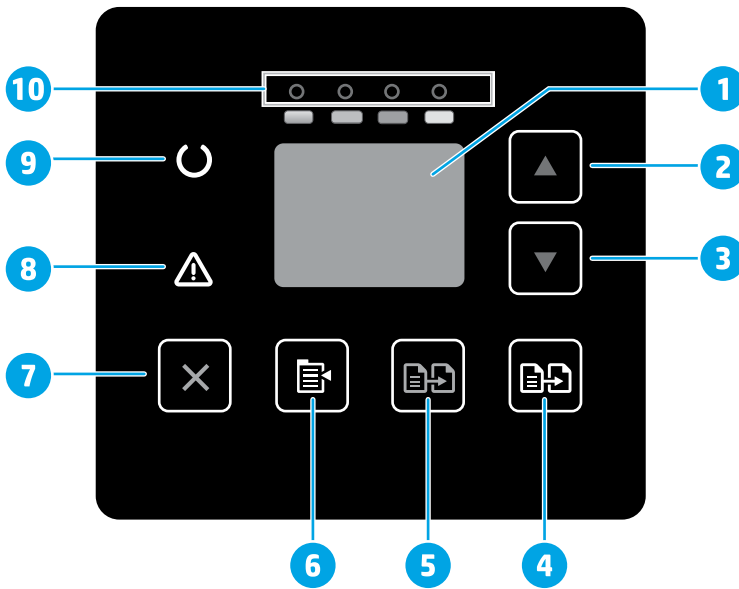



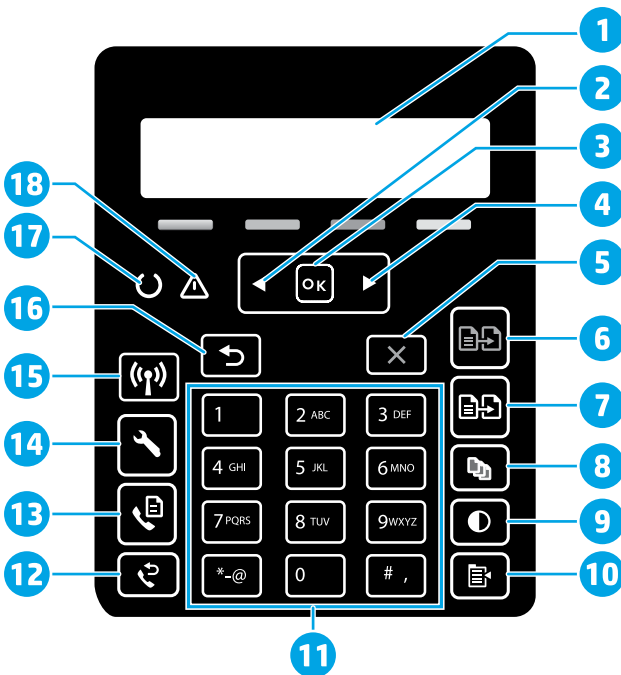

1	Tampilan panel kontrol LED
2	Tombol panah ke atas ▲
3	Tombol panah ke bawah ▼
4	Tombol Start Color Copy / OK (Mulai Salin Warna/OK)
5	Tombol Start Mono Copy (Mulai Salin Mono)
6	Tombol Copy Setup (Pengaturan Salin)
7	Tombol Cancel (Batal)
8	LED Peringatan
9	LED Siap
10	LED Persediaan

### Tampilan panel kontrol LCD 2 baris



1	Tampilan panel kontrol 2 baris	10	Tombol Menu Copy (Salin)
2	Tombol panah ke kiri ◀	11	Papan tombol alfanumerik
3	Tombol OK	12	Tombol Fax Redial (Panggil Ulang Fax) (hanya model faks)
4	Tombol panah ke kanan ▶	13	Tombol Start Fax (Mulai Faks) (hanya model faks)
5	Tombol Cancel (Batal)	14	Tombol Setup (Pengaturan)
6	Tombol Start Mono Copy (Mulai Salin Mono)	15	Tombol Nirkabel (hanya model nirkabel)
7	Tombol Start Color Copy (Mulai Salin Warna)	16	Tombol panah balik ↶
8	Tombol Number of Copies (Jumlah Salinan)	17	LED Siap
9	Tombol Lebih Terang/Gelap	18	LED Peringatan

## Panel kontrol pola lampu

Lampu	Keterangan	Solusi
	Siap	Tidak perlu dilakukan tindakan.
	Kartrid toner hampir habis masa pakainya	Lampu persediaan berkedip bila terjadi kesalahan persediaan, dan menyala tanpa berkedip bila persediaan sangat rendah.
	Kesalahan fatal	Siklus daya. Jika kesalahan masih ada, hubungi layanan pelanggan HP.
	Memproses	Tidak perlu dilakukan tindakan.
	Masalah/Pengisian Manual/Dupleks Manual/Kertas habis/Pintu terbuka/Macet	<ul style="list-style-type: none"> <li>Pengisian Manual/Dupleks Manual - Tekan tombol <b>OK</b> bila siap.</li> <li>Kertas habis - Masukkan kertas.</li> <li>Pintu terbuka - Tutup semua pintu.</li> <li>Masalah/Macet - Lihat Panduan Pengguna.</li> </ul>

## Pesan kesalahan panel kontrol

Pesan Kesalahan	Solusi
Muat Kertas	Masukkan kertas.
<ul style="list-style-type: none"> <li>Menginisialisasi...</li> <li>Membersihkan...</li> <li>Mencetak... Mode pendinginan</li> </ul>	Tidak perlu dilakukan tindakan.
Pintu terbuka	Tutup semua pintu.
<ul style="list-style-type: none"> <li>Macet dalam Baki 1. Atasi kemacetan, lalu tekan <b>OK</b>.</li> <li>Macet di area kartrid. Buka penutup atas dan keluarkan kartrid. Atasi kemacetan.</li> </ul>	Lihat Panduan Pengguna.
<ul style="list-style-type: none"> <li>Pengisian Manual. Polos, Letter. Atau tekan <b>OK</b> untuk menggunakan media yang tersedia.</li> <li>Dupleks Manual. Muat baki 1. Tekan <b>OK</b> untuk melanjutkan.</li> </ul>	Press tombol <b>OK</b> bila siap.
<ul style="list-style-type: none"> <li>Masalah suplai.</li> <li>Pasang kartrid.</li> <li>Kartrid tidak kompatibel.</li> <li>Kartrid diproteksi.</li> <li>Kartrid tidak diotorisasi.</li> </ul>	Keluarkan dan masukkan kembali kartrid toner. Jika kesalahan masih ada, kunjungi <a href="http://www.hp.com/support/ljM182MFP">www.hp.com/support/ljM182MFP</a> .
<ul style="list-style-type: none"> <li>Kartrid sangat rendah.</li> <li>Kartrid bekas atau palsu sedang digunakan.</li> </ul>	Ganti dengan kartrid baru.

## Mendownload dan menginstal perangkat lunak

**CATATAN:** Jangan sambungkan kabel USB hingga diminta untuk melakukannya.

### Metode 1: Download dari [123.hp.com/laserjet](http://123.hp.com/laserjet)

- Kunjungi [123.hp.com/laserjet](http://123.hp.com/laserjet) (Windows) atau [123.hp.com](http://123.hp.com) (OS X), dan klik **Download**.
- Ikuti petunjuk di layar dan perintah untuk menyimpan file di komputer.
- Jalankan file perangkat lunak dari folder tempat menyimpan file.
- Ikuti petunjuk di layar untuk menginstal perangkat lunak.
- Bila diminta untuk memilih jenis sambungan, gunakan pilihan yang tepat untuk jenis sambungan.

### Metode 2: Download dari situs web dukungan printer (Windows)

- Kunjungi [www.hp.com/support/ljM182MFP](http://www.hp.com/support/ljM182MFP).
- Pilih **Software and Drivers** (Perangkat lunak dan Driver).
- Download perangkat lunak untuk model printer dan sistem operasi Anda.
- Jalankan file perangkat lunak dari folder tempat menyimpan file.
- Ikuti petunjuk di layar untuk menginstal perangkat lunak.
- Bila diminta untuk memilih jenis sambungan, gunakan pilihan yang tepat untuk jenis sambungan.

## Metode 1: HP Smart

Gunakan aplikasi HP Smart untuk mengonfigurasi, mencetak, dan lainnya.

1. Pindai kode QR atau kunjungi [123.hp.com](http://123.hp.com).
2. Instal aplikasi HP Smart.
3. Jalankan aplikasi HP Smart dan ikuti petunjuk di layar untuk menyambungkan, mengonfigurasi, mencetak, dan lainnya.



## Metode 2: Wi-Fi Direct (hanya model nirkabel)

Wi-Fi Direct memungkinkan perangkat yang mendukung Wi-Fi, misalnya smartphone, tablet, atau komputer, membuat sambungan jaringan nirkabel langsung ke printer tanpa menggunakan router atau jalur akses nirkabel. Sambungkan ke sinyal Wi-Fi Direct printer menggunakan cara yang sama seperti menyambungkan perangkat yang mendukung Wi-Fi ke jaringan nirkabel atau hotspot baru.

### Mengaktifkan Wi-Fi Direct

Untuk mengkonfigurasi Wi-Fi Direct dari panel kontrol, lakukan langkah berikut:

1. Di panel kontrol printer, tekan tombol Setup (Pengaturan) , kemudian buka menu Network Setup (Pengaturan Jaringan).
2. Buka menu berikut:
  - **Wi-Fi Direct**
  - **On/Off** (Aktif/Tidak Aktif)
3. Sentuh item menu **On** (Aktif).

### Menemukan printer

1. Dari perangkat seluler, aktifkan Wi-Fi, lalu cari jaringan nirkabel.
2. Pilih printer yang ditunjukkan pada panel kontrol printer.  
**Contoh nama printer:** Direct-bb-HP M182 LaserJet

### Selengkapnya tentang pencetakan mobile

Untuk informasi lebih lanjut tentang hal ini dan sistem operasi lainnya (Chrome/Google Cloud Print), kunjungi [www.hp.com/go/LaserJetMobilePrinting](http://www.hp.com/go/LaserJetMobilePrinting) atau pindai kode QR.



## Menggunakan fitur pindai

Gunakan perangkat lunak HP Scan di komputer untuk memulai tugas pindai pada printer.

### Windows

Klik **Start** (Mulai), pilih **Programs** (Program) atau **All Programs** (Semua Program), pilih **HP**, lalu pilih **HP Scan**.

### OS X





Buka folder **Applications** (Aplikasi) dan buka **HP Smart**.

## Mengatasi masalah

### Pemecahan masalah koneksi nirkabel

Pastikan printer telah berada dalam jangkauan jaringan nirkabel. Untuk sebagian besar jaringan, printer harus berada dalam jarak 30 m (100 kaki) dari jalur akses nirkabel (router nirkabel). Kabel USB mungkin diperlukan untuk membuat sambungan sementara antara printer dan komputer. Untuk memastikan bahwa informasi konfigurasi nirkabel telah disinkronisasi dengan benar, jangan sambungkan kabel USB hingga Anda diminta untuk melakukannya.

Ikuti langkah-langkah ini untuk memulihkan pengaturan jaringan:

1. Lepaskan kabel USB dari printer.
2. Tekan dan tahan tombol Nirkabel  pada panel kontrol printer. Bila LED Siap  dan LED Peringatan  mulai berkedip bersamaan, lepas tombol Nirkabel . Printer akan memulihkan jaringan standar secara otomatis dan melakukan start ulang.
3. Bila LED Siap  menyala, lanjutkan dengan menginstal perangkat lunak.

### Panduan pengguna dan informasi berguna untuk dukungan tambahan

Panduan pengguna mencakup informasi tentang penggunaan dan cara mengatasi masalah printer. Informasi ini tersedia di web: Kunjungi [www.hp.com/support/ijM182MFP](http://www.hp.com/support/ijM182MFP).

### Memeriksa pembaruan firmware

1. Kunjungi [www.hp.com/support/ijM182MFP](http://www.hp.com/support/ijM182MFP).
2. Pilih printer atau kategori dari daftar, lalu klik **Drivers** (Driver).
3. Pilih sistem operasi, lalu klik tombol **Next** (Berikutnya).
4. Pilih **Firmware**, lalu klik tombol **Download**.

### Pencetakan nirkabel

Untuk informasi lebih lanjut tentang pencetakan dan konfigurasi nirkabel, kunjungi [www.hp.com/go/wirelessprinting](http://www.hp.com/go/wirelessprinting).







# Color LaserJet Pro MFP M182-M185

## 설명서

English.....3

Bahasa Indonesia.....6

한국어.....9

ไทย.....12

繁體中文.....15

Tiếng Việt.....18

### 도움말 정보? - FAQ

자주 묻는 질문은  
[www.hp.com/support/iiM182MFPFAQ](http://www.hp.com/support/iiM182MFPFAQ)  
 에서 확인하거나 QR 코드를 스캔합니다.



## LED 제어판 보기

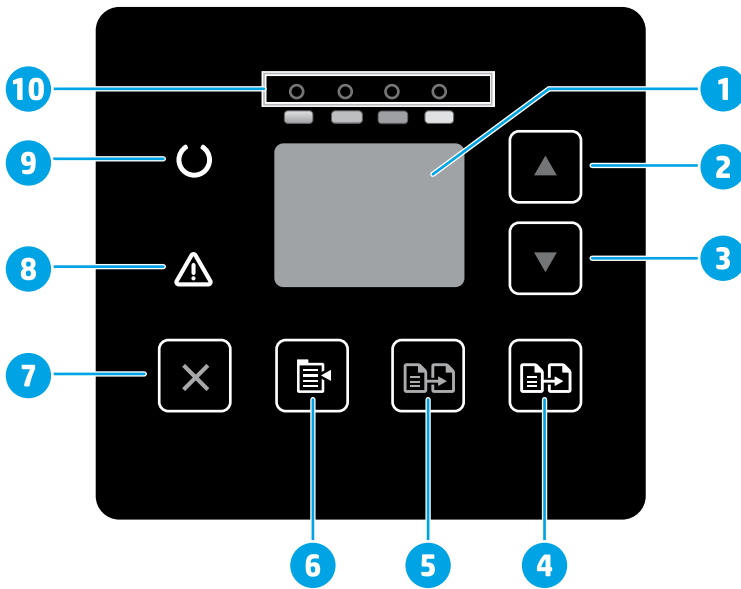

- |    |                |
|----|----------------|
| 1  | 제어판 LED 디스플레이  |
| 2  | 위쪽 화살표 ▲버튼     |
| 3  | 아래쪽 화살표 ▼버튼    |
| 4  | 컬러 복사 시작/확인 버튼 |
| 5  | 흑백 복사 시작 버튼    |
| 6  | 복사 설정 버튼       |
| 7  | 취소 X 버튼        |
| 8  | 주의 ▲LED        |
| 9  | 준비 ○LED        |
| 10 | 소모품 LEDs       |

## 2줄 LCD 제어판 보기

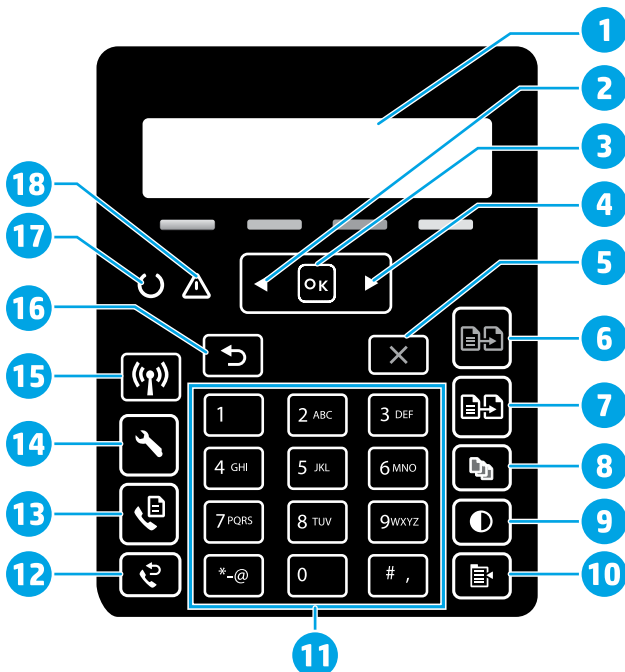

- |   |              |    |                           |
|---|--------------|----|---------------------------|
| 1 | 2줄 제어판 디스플레이 | 10 | 복사 메뉴 버튼                  |
| 2 | 왼쪽 화살표 ◀버튼   | 11 | 영숫자 키패드                   |
| 3 | 확인 버튼        | 12 | 팩스 재다이얼 버튼<br>(팩스 모델만 해당) |
| 4 | 오른쪽 화살표 ▶버튼  | 13 | 팩스 시작 버튼<br>(팩스 모델만 해당)   |
| 5 | 취소 X 버튼      | 14 | 설정 버튼                     |
| 6 | 흑백 복사 시작 버튼  | 15 | 무선 버튼<br>(무선 모델만 해당)      |
| 7 | 컬러 복사 시작 버튼  | 16 | 뒤로 가기 화살표 ↶버튼             |
| 8 | 복사 매수 버튼     | 17 | 준비 ○LED                   |
| 9 | 밝게/어둡게 ●버튼   | 18 | 주의 ▲LED                   |

## 제어판 표시등 패턴

표시등	설명	해결 방법
	준비	취해야 할 조치 없음.
	토너 카트리지의 수명이 끝났음	소모품 오류가 발생하면 소모품 등이 깜박이며, 공급이 매우 적으면 깜박이지 않고 켜집니다.
	치명적 오류	전원 주기. 계속해서 오류가 나타나면, HP 고객 서비스센터에 문의하십시오.
	처리 중	취해야 할 조치 없음.
	오류/수동 공급/수동 양면 인쇄/용지 부족/도어 열림/용지 걸림	<ul style="list-style-type: none"> <li>수동 공급/수동 양면 인쇄 - 준비가 되면 <b>확인</b> 버튼을 누릅니다.</li> <li>용지 부족 - 용지를 넣습니다.</li> <li>도어 열림 - 모든 도어를 고정합니다.</li> <li>오류/용지 걸림 - 사용 설명서를 참조합니다.</li> </ul>

## 제어판 오류 메시지

오류 메시지	해결 방법
용지 넣기	용지 끼우기.
<ul style="list-style-type: none"> <li>초기화 중...</li> <li>청소 중...</li> <li>인쇄 중... 냉각 모드</li> </ul>	취해야 할 조치 없음.
도어가 열려 있음	모든 도어를 고정합니다.
<ul style="list-style-type: none"> <li>용지함 1의 용지 걸림 용지 걸림을 해결한 다음, <b>확인</b>을 누릅니다.</li> <li>카트리지 영역에 용지가 걸려 있습니다. 덮개를 열고 토너 카트리지를 분리합니다. 용지 걸림을 해결합니다.</li> </ul>	사용 설명서를 참조합니다.
<ul style="list-style-type: none"> <li>수동으로 공급합니다. 일반 용지, Letter. 또는 <b>확인</b>을 눌러 사용 가능한 미디어를 사용합니다.</li> <li>수동 양면 인쇄. 용지함 1 적재. 계속하려면, <b>확인</b>을 누릅니다.</li> </ul>	준비가 되면 <b>확인</b> 버튼을 누릅니다.
<ul style="list-style-type: none"> <li>소모품 문제.</li> <li>카트리지 설치</li> <li>호환되지 않는 카트리지.</li> <li>카트리지 보호.</li> <li>정품이 아닌 카트리지</li> </ul>	토너 카트리지 또는 이미징 드럼을 꺼낸 다음 다시 삽입합니다. 오류가 계속 나타나면, <a href="http://www.hp.com/support/ijM182MFP">www.hp.com/support/ijM182MFP</a> 에서 확인합니다.
<ul style="list-style-type: none"> <li>카트리지가 매우 부족합니다.</li> <li>중고 또는 위조품 검정색 카트리지가 사용됨.</li> </ul>	새 카트리지를 교체합니다.

## 소프트웨어 다운로드 및 설치

참고: 알림이 표시되기 전까지는 USB 케이블을 연결하지 마십시오.

### 방법 1: 123.hp.com/laserjet에서 다운로드

1. [123.hp.com/laserjet](http://123.hp.com/laserjet) (Windows) 또는 [123.hp.com](http://123.hp.com) (OS X)로 이동하여 **다운로드**를 클릭합니다.
2. 화면의 안내와 알림에 따라, 컴퓨터에 파일을 저장합니다.
3. 파일이 저장된 폴더에서 소프트웨어 파일을 실행합니다.
4. 화면의 지시에 따라, 소프트웨어를 설치합니다.
5. 연결 유형 선택 알림이 표시되면, 연결 유형에 적합한 옵션을 선택합니다.

### 방법 2: 제품 지원 웹 사이트에서 다운로드(Windows)

1. [www.hp.com/support/ijM182MFP](http://www.hp.com/support/ijM182MFP)에서 확인합니다.
2. **소프트웨어 및 드라이버**를 선택합니다.
3. 해당 프린터 모델 및 운영 체제용 소프트웨어를 다운로드합니다.
4. 파일이 저장된 폴더에서 소프트웨어 파일을 실행합니다.
5. 화면의 지시에 따라, 소프트웨어를 설치합니다.
6. 연결 유형 선택 알림이 표시되면, 연결 유형에 적합한 옵션을 선택합니다.

## 방법 1: HP Smart

HP 스마트 앱을 사용하여 연결, 설정 및 인쇄 등을 실시합니다.

1. QR 코드를 스캔하거나 [123.hp.com](http://123.hp.com)에서 확인합니다.
2. HP 스마트 앱을 설치합니다.
3. HP 스마트 앱을 실행하여 화면에 표시되는 안내에 따라, 연결, 설정 및 인쇄 등을 실시합니다.



## 방법 2: Wi-Fi Direct(무선 모델만 해당)

Wi-Fi Direct를 사용하면, 스마트폰, 태블릿, 컴퓨터와 같은 Wi-Fi 케이블 장치를 무선 라우터나 액세스 지점을 사용하지 않고 무선 네트워크로 직접 프린터에 연결할 수 있습니다. Wi-Fi를 사용할 수 있는 장치를 새 무선 네트워크 또는 핫스팟에 연결하는 경우와 동일한 방법으로 프린터의 Wi-Fi Direct 신호에 연결합니다.

### Wi-Fi Direct 활성화

제어판에서 Wi-Fi Direct를 설정하려면, 다음 단계를 수행합니다.

1. 프린터 제어판에서 설정 버튼을 누른 다음, 네트워크 설정 메뉴를 엽니다.
2. 다음 메뉴를 엽니다.
  - Wi-Fi Direct
  - 켜기/끄기
3. 켜기 메뉴 항목을 터치합니다.

### 프린터 찾기

1. 모바일 장치에서 Wi-Fi를 켜고 무선 네트워크를 검색합니다.
2. 프린터 제어판에 표시되는 프린터를 선택합니다.  
**프린터 이름 예:** Direct-bb-HP M182 Laserjet

### 모바일 인쇄에 대해 자세히 알아보기

이들 운영 체제 및 기타 운영 체제(Chrome/Google Cloud Print)에 대한 자세한 내용은 [www.hp.com/go/LaserJetMobilePrinting](http://www.hp.com/go/LaserJetMobilePrinting)에서 확인하거나 QR 코드를 스캔합니다.



## 스캔 기능 사용

프린터에서 스캔 작업을 시작하려면, 컴퓨터의 HP Scan 소프트웨어를 사용합니다.

### Windows

시작을 클릭한 다음, 프로그램 또는 모든 프로그램, HP, HP Scan을 차례로 선택합니다.

### OS X

응용 프로그램 폴더로 이동한 다음, HP Smart를 엽니다.

## 문제 해결

### 무선 연결 문제해결

프린터가 무선 네트워크 범위 내에 있는지 확인합니다. 대부분의 네트워크에서는 프린터가 무선 액세스 지점(무선 라우터)의 30m(100ft) 이내에 있어야 합니다. USB 케이블을 사용하여 임시로 프린터와 컴퓨터를 연결해야 할 수도 있습니다. 무선 설정 정보가 제대로 동기화되도록 알림이 표시되기 전에는 USB 케이블을 연결하지 마십시오.

네트워크 설정을 복원하려면, 다음 단계를 수행합니다.

1. USB 케이블을 프린터에서 분리합니다.
2. 프린터 제어판에 있는 무선 버튼을 길게 누릅니다. 준비 LED와 주의 LED가 동시에 깜박이면 무선 버튼을 해제합니다. 프린터가 자동으로 네트워크 기본값을 복구하여 다시 시작합니다.
3. 준비 LED가 켜져 있으면, 소프트웨어 설치를 진행합니다.

### 사용 설명서 및 추가 지원 리소스

사용 설명서에 프린터 사용법 및 문제 해결 정보가 포함되어 있습니다. 웹에서 사용할 수 있습니다: [www.hp.com/support/ijM182MFP](http://www.hp.com/support/ijM182MFP)에서 확인합니다.

### 펌웨어 업데이트 확인

1. [www.hp.com/support/ijM182MFP](http://www.hp.com/support/ijM182MFP)에서 확인합니다.
2. 목록에서 프린터 또는 카테고리를 선택한 다음, 드라이버를 클릭합니다.
3. 운영 체제를 선택하고 다음 버튼을 클릭합니다.
4. 펌웨어를 선택하고 다운로드 버튼을 클릭합니다.

### 무선 인쇄

무선 인쇄 및 무선 설정에 대한 자세한 내용은 [www.hp.com/go/wirelessprinting](http://www.hp.com/go/wirelessprinting)에서 확인합니다.



English.....3  
 Bahasa Indonesia.....6  
 한국어.....9  
 ไทย.....12  
 繁體中文.....15  
 Tiếng Việt.....18



# Color LaserJet Pro MFP M182-M185

## คู่มืออ้างอิง

### ต้องการความช่วยเหลือหรือไม่ - คำถามที่พบบ่อย

หากต้องการดูคำถามที่พบบ่อยให้ไปที่  
[www.hp.com/support/liM182MFPFAQ](http://www.hp.com/support/liM182MFPFAQ)  
 หรือสแกนรหัส QR นี้



### จอแสดงผลแผงควบคุม LED

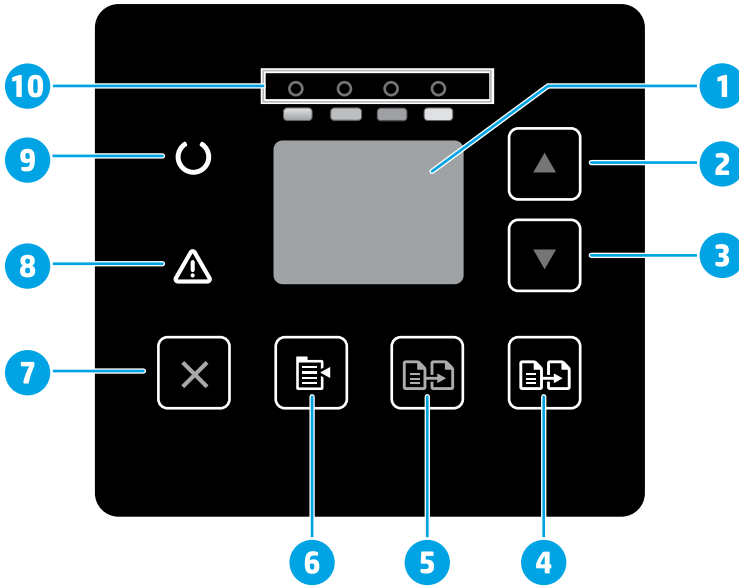



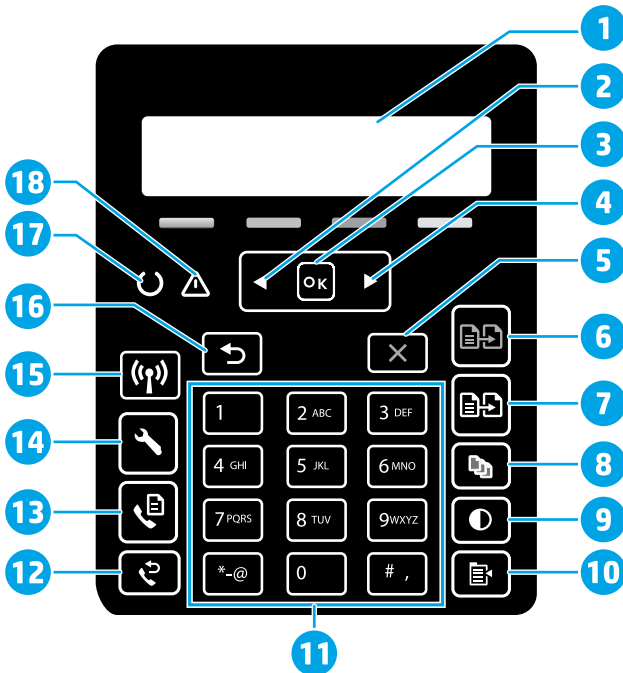

1	หน้าจอ LED แผงควบคุม
2	ปุ่มลูกศรขึ้น ▲
3	ปุ่มลูกศรลง ▼
4	ปุ่มเริ่มทำสำเนาสี / ตกลง ๒๖
5	ปุ่มเริ่มทำสำเนาขาวดำ ๒๖
6	ปุ่มการตั้งค่าสำเนา ๒๖
7	ปุ่มยกเลิก X
8	ไฟ LED เตือน Δ
9	ไฟ LED พร้อม U
10	ไฟ LED อุปกรณ์สิ้นเปลือง

### จอแสดงผลแผงควบคุม LCD แบบ 2 บรรทัด



1	จอแสดงผลแผงควบคุม 2 บรรทัด	10	ปุ่มเมนูสำเนา ๒๖
2	ปุ่มลูกศรซ้าย ◀	11	แผงปุ่มกดเลขและตัวอักษร
3	ปุ่ม OK	12	ปุ่มโทรซ้ำโทรสาร ๑ (รุ่นแฟกซ์เท่านั้น)
4	ปุ่มลูกศรขวา ▶	13	ปุ่มเริ่มโทรสาร ๑ (รุ่นแฟกซ์เท่านั้น)
5	ปุ่มยกเลิก X	14	ปุ่มการตั้งค่า ๒๖
6	ปุ่มเริ่มทำสำเนาขาวดำ ๒๖	15	ปุ่มไร้สาย ๑๖ (เฉพาะรุ่นไร้สายเท่านั้น)
7	ปุ่มเริ่มทำสำเนาสี ๒๖	16	ปุ่มลูกศรย้อนกลับ ↶
8	ปุ่มจำนวนสำเนา ๒๖	17	ไฟ LED พร้อม U
9	ปุ่มจางลง/เข้มขึ้น ●	18	ไฟ LED เตือน Δ

## รูปแบบไฟของแผงควบคุม

ไฟ	คำอธิบาย	วิธีการแก้ไข
	พร้อม	ไม่ต้องทำอะไร
	ตลับหมึกหมดอายุ	ไฟอุปกรณ์สิ้นเปลืองจะกะพริบเมื่อเกิดข้อผิดพลาดอุปกรณ์สิ้นเปลือง และจะสว่างโดยไม่กะพริบเมื่ออุปกรณ์สิ้นเปลืองเหลือน้อยมาก
	ความผิดพลาดรุนแรง	รอบการเปิด/ปิด หากยังมีความผิดพลาด ติดต่อศูนย์บริการลูกค้า HP
	กำลังดำเนินการ	ไม่ต้องทำอะไร
	ผิดพลาด/ป้อนด้วยตนเอง/พิมพ์สองด้านด้วยตนเอง/ กระดาษหมด/ประตูเปิด/กระดาษติด	<ul style="list-style-type: none"> <li>ป้อนด้วยตนเอง/พิมพ์สองด้านด้วยตนเอง - กดปุ่ม <b>OK</b> เมื่อพร้อม</li> <li>กระดาษหมด - ป้อนกระดาษ</li> <li>ประตูเปิด - ตรวจสอบทุกประตู</li> <li>ผิดพลาด/กระดาษติด - อ้างอิงคู่มือผู้ใช้</li> </ul>

## ข้อความแสดงข้อผิดพลาดแผงควบคุม

ข้อความแสดงข้อผิดพลาด	วิธีการแก้ไข
ใส่กระดาษ	ใส่กระดาษ
<ul style="list-style-type: none"> <li>กำลังเริ่มต้น...</li> <li>กำลังทำความสะอาด...</li> <li>กำลังพิมพ์... โหมดทำให้เครื่องเย็นลง</li> </ul>	ไม่ต้องทำอะไร
ประตูเปิด	ปิดทุกประตู
<ul style="list-style-type: none"> <li>กระดาษติดในถาด 1 ดึงกระดาษที่ติดออกและกด <b>OK</b></li> <li>กระดาษติดในส่วนตลับหมึก เปิดฝาด้านบนและถอดตลับหมึกออก นำกระดาษติดออก</li> </ul>	ดูในคู่มือผู้ใช้
<ul style="list-style-type: none"> <li>ป้อนด้วยตนเอง กระดาษเปล่า จดหมาย หรือกด <b>OK</b> เพื่อใช้สื่อที่มี</li> <li>การพิมพ์สองด้านด้วยตนเอง ใส่ถาด 1 กด <b>OK</b> เพื่อดำเนินการต่อ</li> </ul>	กดปุ่ม <b>OK</b> เมื่อพร้อม
<ul style="list-style-type: none"> <li>ปัญหาจากอุปกรณ์สิ้นเปลือง</li> <li>ติดตั้งตลับหมึก</li> <li>ตลับหมึกเข้ากันไม่ได้</li> <li>ตลับหมึกได้รับการปกป้อง</li> <li>ตลับหมึกที่ไม่ได้รับอนุญาต</li> </ul>	เอาตลับหมึกออกแล้วใส่เข้าไปใหม่ หากยังพบข้อผิดพลาดอยู่ โปรดไปที่ <a href="http://www.hp.com/support/liM182MFP">www.hp.com/support/liM182MFP</a>
<ul style="list-style-type: none"> <li>ตลับหมึกเหลือน้อยมาก</li> <li>ตลับหมึกพิมพ์ที่ใช้แล้วหรือปลอมถูกนำมาใช้</li> </ul>	โปรดเปลี่ยนเป็นตลับหมึกใหม่

## ดาวน์โหลดและติดตั้งซอฟต์แวร์

หมายเหตุ: อย่าเพิ่งต่อสาย USB จนกว่าโปรแกรมการติดตั้งจะพร้อมให้ต่อ

### วิธีที่ 1: ดาวน์โหลดจาก [123.hp.com/laserjet](http://123.hp.com/laserjet)

- ไปยัง [123.hp.com/laserjet](http://123.hp.com/laserjet) (Windows) หรือ [123.hp.com](http://123.hp.com) (OS X) และคลิก **Download** (ดาวน์โหลด)
- ทำตามคำแนะนำบนหน้าจอและพร้อมท์ เพื่อบันทึกไฟล์ในคอมพิวเตอร์
- เปิดไฟล์ซอฟต์แวร์จากโฟลเดอร์ที่บันทึกไฟล์ไว้
- ทำตามคำแนะนำบนหน้าจอเพื่อติดตั้งซอฟต์แวร์
- เมื่อพร้อมท์ให้เลือกประเภทของการเชื่อมต่อ โปรดเลือกตัวเลือกที่เหมาะสมสำหรับประเภทของการเชื่อมต่อ

### วิธีที่ 2: ดาวน์โหลดจากเว็บไซต์การสนับสนุนเครื่องพิมพ์ (Windows)

- ไปที่ [www.hp.com/support/liM182MFP](http://www.hp.com/support/liM182MFP)
- เลือก **Software and Drivers** (ซอฟต์แวร์และไดรเวอร์)
- ดาวน์โหลดซอฟต์แวร์สำหรับรุ่นเครื่องพิมพ์และระบบปฏิบัติการของคุณ
- เปิดไฟล์ซอฟต์แวร์จากโฟลเดอร์ที่บันทึกไฟล์ไว้
- ทำตามคำแนะนำบนหน้าจอเพื่อติดตั้งซอฟต์แวร์
- เมื่อพร้อมท์ให้เลือกประเภทของการเชื่อมต่อ โปรดเลือกตัวเลือกที่เหมาะสมสำหรับประเภทของการเชื่อมต่อ

## วิธีที่ 1: HP Smart

ใช้แอป HP Smart เพื่อตั้งค่า พิมพ์ และอื่นๆ

1. สแกนรหัส QR นี้หรือไปที่ [123.hp.com](http://123.hp.com)
2. ติดตั้งแอป HP Smart
3. เรียกใช้แอป HP Smart และทำตามคำแนะนำบนหน้าจอ เพื่อเชื่อมต่อ ตั้งค่า พิมพ์ และอื่นๆ



## วิธีที่ 2: Wi-Fi Direct (รุ่นไร้สายเท่านั้น)

Wi-Fi Direct อนุญาตให้อุปกรณ์ที่ใช้งาน Wi-Fi ได้ อาทิเช่น สมาร์ทโฟน แท็บเล็ต หรือคอมพิวเตอร์ เชื่อมต่อกับเครื่องพิมพ์ผ่านเครือข่ายไร้สายได้โดยตรง โดยไม่ต้องใช้เราเตอร์หรือจุดเข้าใช้งานไร้สาย โดยวิธีการเชื่อมต่อกับสัญญาณ Wi-Fi Direct ของเครื่องพิมพ์จะเหมือนกับวิธีการเชื่อมต่ออุปกรณ์ที่ใช้ Wi-Fi ได้กับเครือข่ายไร้สายหรือฮอตสปอตใหม่ทั่วไป

### เปิดใช้งาน Wi-Fi Direct

ในการตั้งค่า Wi-Fi Direct จากแผงควบคุม ให้ดำเนินการตามขั้นตอนต่อไปนี้จนเสร็จสมบูรณ์

1. บนแผงควบคุมเครื่องพิมพ์ กดปุ่มการตั้งค่า แล้วหลังจากนั้นให้เปิดเมนู การตั้งค่าเครือข่าย
2. เปิดเมนูดังต่อไปนี้:
  - Wi-Fi Direct
  - เปิด/ปิด
3. แตะรายการเมนู เปิด

### ค้นหาเครื่องพิมพ์

1. เปิด Wi-Fi ในอุปกรณ์เคลื่อนที่ และค้นหาเครือข่ายไร้สาย
2. เลือกเครื่องพิมพ์ตามที่แสดงบนแผงควบคุมเครื่องพิมพ์ ตัวอย่างชื่อเครื่องพิมพ์ เช่น Direct-bb-HP M182 Laserjet

### ศึกษาเพิ่มเติมเกี่ยวกับการพิมพ์ผ่านอุปกรณ์เคลื่อนที่

หากต้องการข้อมูลเพิ่มเติมเกี่ยวกับการพิมพ์ผ่านอุปกรณ์เคลื่อนที่และระบบปฏิบัติการอื่นๆ (Chrome/Google Cloud Print) ให้ไปที่ [www.hp.com/go/LaserJetMobilePrinting](http://www.hp.com/go/LaserJetMobilePrinting) หรือสแกนรหัส QR นี้



## ใช้คุณสมบัติการสแกน

ใช้ซอฟต์แวร์ HP Scan ในคอมพิวเตอร์ เพื่อเริ่มงานสแกนที่เครื่องพิมพ์

### Windows

คลิก เริ่ม เลือก โปรแกรม หรือ โปรแกรมทั้งหมด เลือก HP จากนั้นเลือก HP Scan

### OS X

ไปที่โฟลเดอร์ แอปพลิเคชัน และเปิด HP Smart

## การแก้ไขปัญหาเบื้องต้น

### (๑) การแก้ไขปัญหาการเชื่อมต่อเครือข่ายไร้สาย

ตรวจสอบว่าเครื่องพิมพ์อยู่ภายในช่วงของเครือข่ายไร้สาย โดยในเครือข่ายส่วนใหญ่เครื่องพิมพ์ต้องอยู่ภายในช่วง 30 ม. (100 ฟุต) ของจุดเข้าใช้งานไร้สาย (เราเตอร์ไร้สาย) คุณอาจต้องใช้สาย USB เพื่อการเชื่อมต่อระหว่างเครื่องพิมพ์กับคอมพิวเตอร์ชั่วคราว และเพื่อให้มั่นใจว่าข้อมูลการตั้งค่าเครือข่ายไร้สายตรงกัน อย่าเพิ่งเชื่อมต่อสาย USB จนกว่าระบบจะพร้อมให้เชื่อมต่อ

ทำตามขั้นตอนเหล่านี้เพื่อเรียกคืนการตั้งค่าเครือข่าย

1. ถอดสาย USB ออกจากเครื่องพิมพ์
2. กดปุ่มไร้สาย บนแผงควบคุมเครื่องพิมพ์ค้างไว้ เมื่อไฟ LED พร้อม และ LED เตือน เริ่มกะพริบต่อเนื่องกัน ให้ปล่อยมือจากปุ่มไร้สาย เครื่องพิมพ์จะคืนค่าเริ่มต้นเครือข่ายอัตโนมัติและเริ่มใหม่
3. เมื่อไฟ LED พร้อม ติดสว่างให้ดำเนินการติดตั้งซอฟต์แวร์ต่อ

คู่มือผู้ใช้และทรัพยากรสนับสนุนเพิ่มเติม

คู่มือผู้ใช้จะมีข้อมูลการใช้เครื่องพิมพ์และการแก้ไขปัญหาเบื้องต้น ซึ่งหาได้จากในเว็บต่อไปนี้: [www.hp.com/support/lj182MFP](http://www.hp.com/support/lj182MFP)

ตรวจสอบอัปเดตเฟิร์มแวร์

1. ไปที่ [www.hp.com/support/lj182MFP](http://www.hp.com/support/lj182MFP)
2. เลือกเครื่องพิมพ์หรือหมวดหมู่จากรายการ จากนั้นคลิก Drivers (ไดรเวอร์)
3. เลือกระบบปฏิบัติการ และคลิกปุ่ม Next (ถัดไป)
4. เลือก Firmware (เฟิร์มแวร์) และคลิกปุ่ม Download (ดาวน์โหลด)

### การพิมพ์แบบไร้สาย

หากต้องการข้อมูลเพิ่มเติมเกี่ยวกับการพิมพ์แบบไร้สายและการตั้งค่าระบบไร้สาย ให้ไปที่ [www.hp.com/go/wirelessprinting](http://www.hp.com/go/wirelessprinting)





# Color LaserJet Pro MFP M182-M185

## 參考指南

English.....	3
Bahasa Indonesia.....	6
한국어.....	9
ไทย.....	12
繁體中文.....	15
Tiếng Việt.....	18

### 需要說明？ - 常見問題解答

如需常見問題解答，請前往  
[www.hp.com/support/liM182MFPFAQ](http://www.hp.com/support/liM182MFPFAQ)，  
 或掃描 QR 代碼。



### LED 控制面板視圖

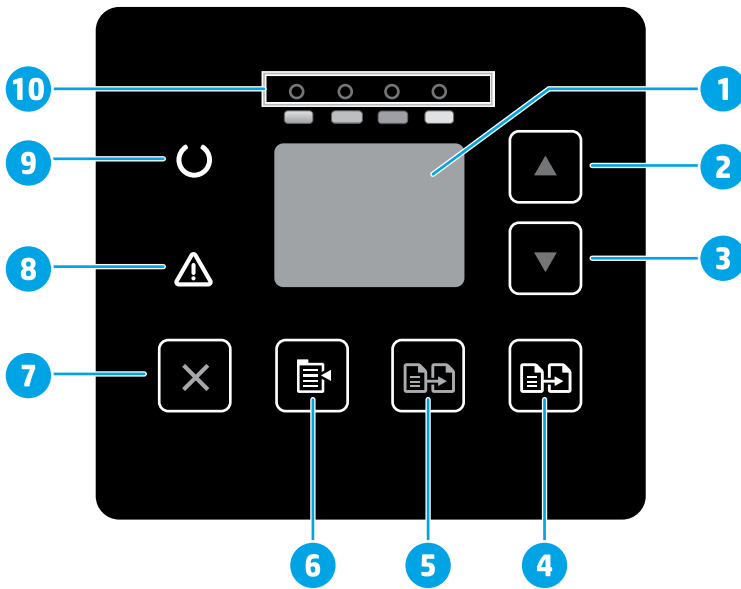



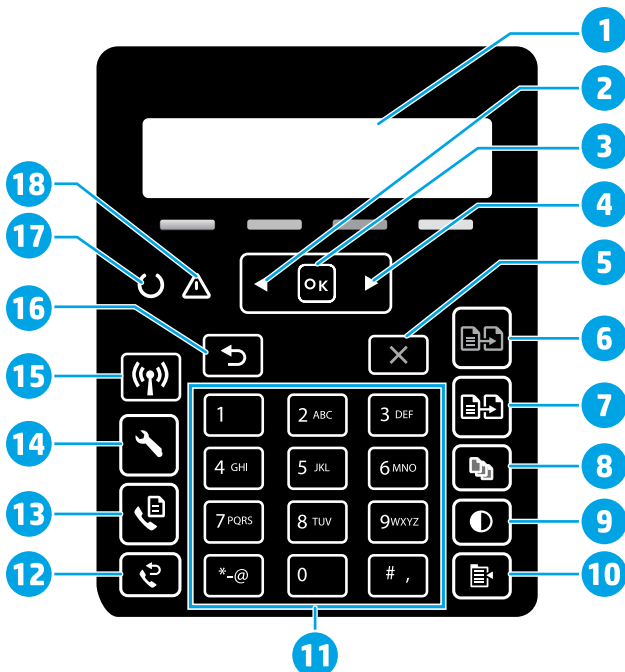

- |    |                |
|----|----------------|
| 1  | 控制面板 LED 顯示器   |
| 2  | 向上箭號按鈕▲        |
| 3  | 向下箭號▼按鈕        |
| 4  | 開始彩色影印 / OK 按鈕 |
| 5  | 開始單色影印 按鈕      |
| 6  | 影印設定 按鈕        |
| 7  | 取消 × 按鈕        |
| 8  | 注意 ▲ LED       |
| 9  | 就緒 ○ LED       |
| 10 | 耗材 LED         |

### 雙行 LCD 控制面板視圖



- |   |            |    |                     |
|---|------------|----|---------------------|
| 1 | 雙行控制面板顯示幕  | 10 | 影印功能表 按鈕            |
| 2 | 左箭頭 ◀ 按鈕   | 11 | 英數字元鍵盤              |
| 3 | OK 按鈕      | 12 | 重撥傳真 按鈕<br>(僅限傳真機型) |
| 4 | 右箭頭 ▶ 按鈕   | 13 | 開始傳真 按鈕<br>(僅限傳真機型) |
| 5 | 取消 × 按鈕    | 14 | 設定 按鈕               |
| 6 | 開始單色影印 按鈕  | 15 | 無線 按鈕<br>(僅限無線機型)   |
| 7 | 開始彩色影印 按鈕  | 16 | 返回箭號 ◂ 按鈕           |
| 8 | 份數 按鈕      | 17 | 就緒 ○ LED            |
| 9 | 調淺/加深 ● 按鈕 | 18 | 注意 ▲ LED            |

## 控制面板指示燈模式

指示燈	說明	解決方案
	就緒	沒有動作需要執行。
	碳粉匣使用壽命已達終點	「耗材」指示燈會在發生耗材錯誤時閃爍，如果燈號亮起但不閃爍，表示耗材存量嚴重不足。
	嚴重錯誤	將電源關閉後，再重新開啟。如果錯誤仍然存在，請致電與 HP 客戶服務聯繫。
	處理中	沒有動作需要執行。
	錯誤/手動送紙/手動雙面列印/紙張用完/擋門已打開/夾紙	<ul style="list-style-type: none"> <li>手動送紙/手動雙面列印 - 就緒燈號亮起時，按下 <b>OK</b> 按鈕。</li> <li>紙張用完 - 放入紙張。</li> <li>擋門已打開 - 關上所有擋門。</li> <li>錯誤/夾紙 - 請參閱使用指南。</li> </ul>

## 控制面板錯誤訊息

錯誤訊息	解決方案
裝入紙張	放入紙張。
<ul style="list-style-type: none"> <li>正在初始化...</li> <li>正在清潔...</li> <li>列印中...冷卻模式</li> </ul>	沒有動作需要執行。
擋門已開啟	關上所有擋門。
<ul style="list-style-type: none"> <li>紙匣 1 卡紙。清除卡紙，然後按下 <b>OK</b>。</li> <li>碳粉匣區域卡紙。打開上蓋板，並取出碳粉匣。清除夾紙。</li> </ul>	請參閱使用指南。
<ul style="list-style-type: none"> <li>手動送紙。Plain、Letter。或按下 <b>OK</b> 以使用可用的紙材。</li> <li>手動雙面列印。裝入 1 號紙匣。按下 <b>OK</b> 以繼續作業。</li> </ul>	就緒燈號亮起時，按下 <b>OK</b> 按鈕。
<ul style="list-style-type: none"> <li>耗材問題。</li> <li>安裝碳粉匣。</li> <li>不相容的碳粉匣。</li> <li>受保護的碳粉匣。</li> <li>未經授權使用的碳粉匣。</li> </ul>	將碳粉匣取出後，再重新放入。如果錯誤訊息仍未消失，則前往 <a href="http://www.hp.com/support/ljM182MFP">www.hp.com/support/ljM182MFP</a> 。
<ul style="list-style-type: none"> <li>碳粉匣碳粉嚴重不足。</li> <li>已用過或盜版的碳粉匣。</li> </ul>	使用新的碳粉匣進行更換。

## 下載與安裝軟體

附註：在接獲提示前，請勿連接 USB 連接線。

### 方法 1：從 [123.hp.com/laserjet](http://123.hp.com/laserjet) 下載

- 請前往 [123.hp.com/laserjet](http://123.hp.com/laserjet) (Windows) 或 [123.hp.com](http://123.hp.com) (OS X)，然後按一下**下載**。
- 請依照螢幕上的指示和提示，將檔案儲存至電腦。
- 從儲存這個軟體檔案的資料夾中，啟動軟體檔案。
- 依照螢幕上的指示，安裝軟體。
- 在出現選擇連線類型的提示時，選擇適合連線類型的選項

### 方法 2：從印表機支援網站下載 (Windows)

- 前往 [www.hp.com/support/ljM182MFP](http://www.hp.com/support/ljM182MFP)。
- 選擇軟體和驅動程式。
- 下載您印表機機型和作業系統適用的軟體。
- 從儲存這個軟體檔案的資料夾中，啟動軟體檔案。
- 依照螢幕上的指示，安裝軟體。
- 在出現選擇連線類型的提示時，選擇適合連線類型的選項



## 方法 1：HP Smart

使用 HP Smart 應用程式，進行設定、列印和其他動作。

1. 掃描 QR 碼，或前往 [123.hp.com](http://123.hp.com)。
2. 安裝 HP Smart 應用程式。
3. 執行 HP Smart 應用程式，然後依照畫面上的指示，進行連線、設定、列印和其他動作。



## 方法 2：Wi-Fi Direct (僅限無線機型)

Wi-Fi Direct 可讓具備 Wi-Fi 功能的裝置 (例如智慧型手機、平板電腦或電腦) 在沒有使用無線路由器或存取點的情況下，直接與印表機進行無線網路連線。使用具備 Wi-Fi 功能的裝置連接至新的無線網路或熱點的相同方法，連接印表機的 Wi-Fi Direct 訊號。

### 啟用 Wi-Fi Direct

若要從控制面板設定 Wi-Fi Direct，請完成下列步驟：

1. 在印表機控制面板上，按下設定 按鈕，接著開啟網路設定功能表。
2. 開啟下列功能表：
  - Wi-Fi Direct
  - 開/關
3. 觸控開啟功能表項目。

### 探索印表機

1. 在行動裝置上，開啟 Wi-Fi，然後搜尋無線網路。
2. 選擇在印表機控制面板上所顯示的印表機名稱。  
印表機名稱範例：Direct-bb-HP M182 Laserjet

### 進一步了解行動列印

如需有關這些和其他作業系統 (Chrome/Google 雲端列印) 的更多資訊，請前往 [www.hp.com/go/LaserJetMobilePrinting](http://www.hp.com/go/LaserJetMobilePrinting)，或掃描 QR 碼。



## 使用掃描功能

使用電腦上的 HP Scan 軟體，啟動印表機的掃描工作。

### Windows

按一下**開始**，選取**程式集**或**所有程式**，接著選取 **HP**，再選擇 **HP Scan**。

### OS X

前往**應用程式**資料夾，並開啟 **HP Smart**。

## 疑難排解

### 無線連線設定疑難排解

確認印表機確實位於無線網路範圍內。對多數網路而言，印表機必須是在距離無線存取點 (無線路由器) 30 公尺 (100 英尺) 以內的位置。可能需要使用 USB 纜線暫時連接印表機與電腦。為確保正確同步無線設定資訊，在出現提示前，請勿連接 USB 纜線。

依照這些步驟來還原網路設定：

1. 從印表機拔下 USB 連接線。
2. 在印表機控制面板上，按住無線 按鈕。當就緒 和注意 指示燈同時開始閃爍時，放開無線 按鈕。印表機將自動還原成網路預設值，並且重新開機。
3. 當就緒 亮起時，繼續執行安裝軟體。

### 使用指南和其他支援資源

使用指南包含印表機使用方式及疑難排解資訊。使用指南也有提供網路版：前往 [www.hp.com/support/ljM182MFP](http://www.hp.com/support/ljM182MFP)。

#### 查看韌體更新

1. 前往 [www.hp.com/support/ljM182MFP](http://www.hp.com/support/ljM182MFP)。
2. 從清單中選擇印表機或類別，然後按一下**驅動程式**。
3. 選擇作業系統，然後按一下**下一步**按鈕。
4. 選擇**韌體**，然後按一下**下載**按鈕。

### 無線列印

如需關於無線列印及無線設定的詳細資訊，請前往 [www.hp.com/go/wirelessprinting](http://www.hp.com/go/wirelessprinting)。





# Color LaserJet Pro MFP M182-M185

## Hướng dẫn tham khảo

### Bạn cần hỗ trợ? - ❗ Câu hỏi thường gặp

Để xem những câu hỏi thường gặp, hãy truy cập vào [www.hp.com/support/ljM182MFPFAQ](http://www.hp.com/support/ljM182MFPFAQ) hoặc quét mã QR.



### Giao diện bảng điều khiển LED

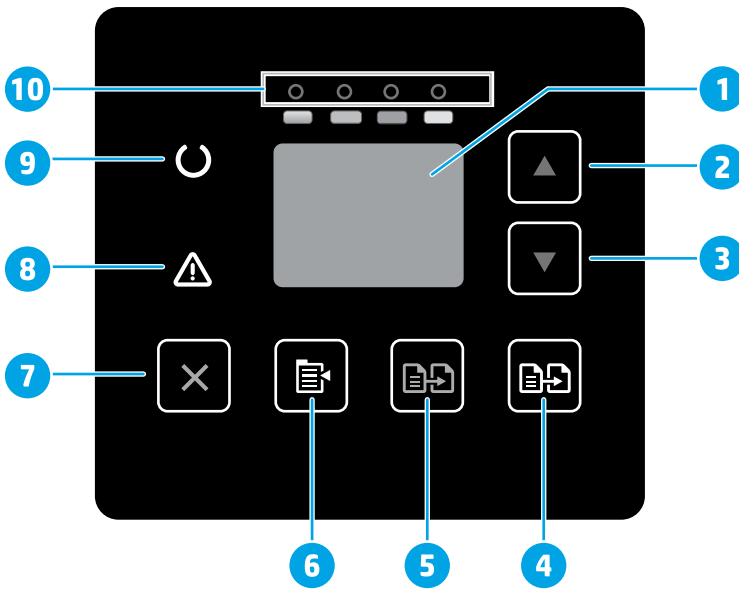

- |    |                                 |
|----|---------------------------------|
| 1  | Màn hình bảng điều khiển LED    |
| 2  | Nút mũi tên Lên ▲               |
| 3  | Nút mũi tên Xuống ▼             |
| 4  | Nút Bắt đầu photocopy màu / OK  |
| 5  | Nút Bắt đầu photocopy đen trắng |
| 6  | Nút Cài đặt photocopy           |
| 7  | Nút Hủy ✕                       |
| 8  | Đèn LED Chú ý ⚠                 |
| 9  | Đèn LED Sẵn sàng ⓪              |
| 10 | Đèn LED Mục in                  |

### Giao diện bảng điều khiển LCD 2 dòng

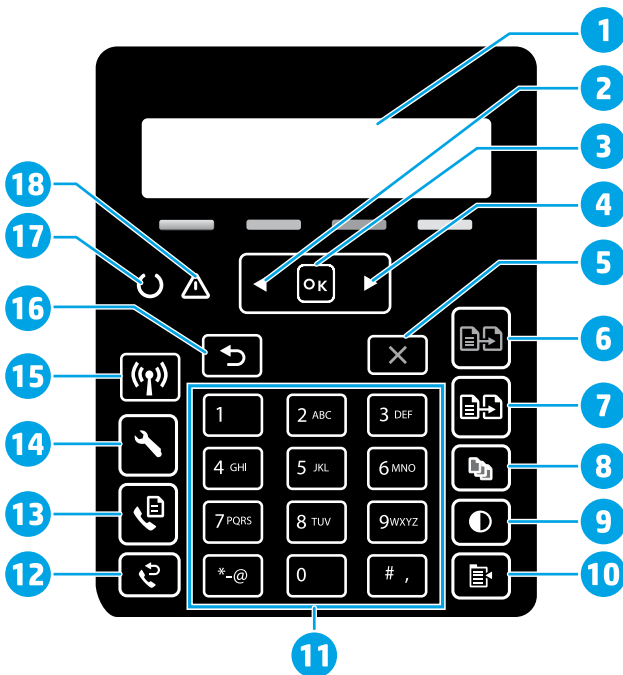

- |   |                                 |    |   |
|---|---------------------------------|----|---|
| 1 | Màn hình bảng điều khiển 2 dòng | 10 | Nút Menu photocopy                              |
| 2 | Nút mũi tên Trái ◀              | 11 | Bàn phím chữ và số                              |
| 3 | Nút OK                          | 12 | Nút Quay lại số fax (chỉ dành cho kiểu máy fax) |
| 4 | Nút mũi tên Phải ▶              | 13 | Nút Bắt đầu Fax (chỉ dành cho kiểu máy fax)     |
| 5 | Nút Hủy ✕                       | 14 | Nút Cài đặt                                     |
| 6 | Nút Bắt đầu photocopy đen trắng | 15 | Nút Không dây (chỉ dành cho mẫu không dây)      |
| 7 | Nút Bắt đầu photocopy màu       | 16 | Nút mũi tên Quay lại ↶                          |
| 8 | Nút Số bản sao                  | 17 | Đèn LED Sẵn sàng ⓪                              |
| 9 | Nút Sáng hơn/Tối hơn            | 18 | Đèn LED Chú ý ⚠                                 |

## Mẫu đèn bảng điều khiển

Đèn	Mô tả	Giải pháp
	Sẵn sàng	Không cần thực hiện hành động nào.
	Hộp bột mực gần hết hạn sử dụng	Đèn Mực in sẽ nhấp nháy khi xảy ra lỗi mực in; đèn sẽ sáng lên và không nhấp nháy khi mực in sắp hết.
	Lỗi nghiêm trọng	Khởi động lại nguồn. Nếu lỗi vẫn xảy ra, hãy gọi dịch vụ khách hàng của HP.
	Đang xử lý	Không cần thực hiện hành động nào.
	Lỗi/Nạp giấy thủ công/In hai mặt thủ công/ Hết giấy/Cửa mở/Kẹt giấy	<ul style="list-style-type: none"> <li>Nạp giấy thủ công/In hai mặt thủ công – Nhấn nút <b>OK</b> khi sẵn sàng.</li> <li>Hết giấy – Đặt giấy vào.</li> <li>Cửa mở – Cố định tất cả các cửa.</li> <li>Lỗi/Kẹt giấy – Tham khảo Hướng dẫn sử dụng.</li> </ul>

## Thông báo lỗi bảng điều khiển

Thông báo lỗi	Giải pháp
Nạp giấy	Đặt giấy vào.
<ul style="list-style-type: none"> <li>Đang bắt đầu...</li> <li>Đang vệ sinh...</li> <li>Đang in... Chế độ Làm mát</li> </ul>	Không cần thực hiện hành động nào.
Cửa mở	Cố định tất cả các cửa.
<ul style="list-style-type: none"> <li>Kẹt giấy trong Khay 1. Xử lý kẹt giấy rồi nhấn <b>OK</b>.</li> <li>Kẹt giấy ở vùng hộp mực. Mở nắp trên cùng và tháo hộp mực. Xử lý kẹt giấy.</li> </ul>	Tham khảo Hướng dẫn sử dụng.
<ul style="list-style-type: none"> <li>Nạp giấy thủ công. Giấy thường, Giấy khổ Letter. Hoặc nhấn <b>OK</b> để sử dụng giấy in sẵn có.</li> <li>In hai mặt thủ công. Nạp giấy khay 1. Nhấn <b>OK</b> để tiếp tục.</li> </ul>	Nhấn nút <b>OK</b> khi sẵn sàng.
<ul style="list-style-type: none"> <li>Vấn đề về mực in.</li> <li>Lắp hộp mực.</li> <li>Hộp mực không tương thích.</li> <li>Hộp mực được bảo vệ.</li> <li>Hộp mực không hợp lệ.</li> </ul>	Tháo hộp mực ra và lắp lại. Nếu lỗi vẫn xảy ra, hãy truy cập vào <a href="http://www.hp.com/support/ljM182MFP">www.hp.com/support/ljM182MFP</a> .
<ul style="list-style-type: none"> <li>Hộp mực sắp hết.</li> <li>Đang dùng hộp mực già hoặc đã qua sử dụng.</li> </ul>	Thay hộp mực mới.

## Tải xuống và cài đặt phần mềm

**LƯU Ý:** Không cắm cáp USB cho tới khi bạn được nhắc làm điều đó.

### Phương pháp 1: Tải xuống từ trang web [123.hp.com/laserjet](http://123.hp.com/laserjet)

- Truy cập vào [123.hp.com/laserjet](http://123.hp.com/laserjet) (Windows) hoặc [123.hp.com](http://123.hp.com) (OS X) rồi nhấp vào **Download** (Tải xuống).
- Làm theo hướng dẫn trên màn hình và trên lời nhắc để lưu tệp vào máy tính.
- Khởi chạy tệp phần mềm từ thư mục lưu tệp.
- Làm theo hướng dẫn trên màn hình để cài đặt phần mềm.
- Khi được nhắc chọn loại kết nối, hãy chọn loại kết nối phù hợp.

### Phương pháp 2: Tải xuống từ trang web hỗ trợ máy in (Windows)

- Truy cập vào [www.hp.com/support/ljM182MFP](http://www.hp.com/support/ljM182MFP).
- Chọn **Software and Drivers** (Phần mềm và trình điều khiển).
- Tải xuống phần mềm cho kiểu máy in và hệ điều hành của bạn.
- Khởi chạy tệp phần mềm từ thư mục lưu tệp.
- Làm theo hướng dẫn trên màn hình để cài đặt phần mềm.
- Khi được nhắc chọn loại kết nối, hãy chọn loại kết nối phù hợp.

## Phương pháp 1: HP Smart

Sử dụng ứng dụng HP Smart để thiết lập, in và hơn thế nữa.

1. Quét mã QR hoặc truy cập vào [123.hp.com](http://123.hp.com).
2. Cài đặt ứng dụng HP Smart.
3. Chạy ứng dụng HP Smart và làm theo hướng dẫn trên màn hình để kết nối, thiết lập, in và hơn thế nữa.



## Phương pháp 2: Wi-Fi Direct (chỉ dành cho kiểu máy không dây)

Wi-Fi Direct cho phép các thiết bị tương thích với Wi-Fi (như điện thoại thông minh, máy tính bảng hoặc máy tính) kết nối không dây trực tiếp với máy in mà không cần sử dụng điểm truy cập hoặc bộ định tuyến không dây. Kết nối với tín hiệu Wi-Fi Direct của máy in theo cách giống như các thiết bị tương thích Wi-Fi kết nối với điểm truy cập hoặc mạng không dây mới.

### Bật Wi-Fi Direct

Để thiết lập Wi-Fi Direct từ bảng điều khiển, hãy hoàn tất các bước sau:

1. Trên bảng điều khiển máy in, bấm vào nút Setup (Cài đặt) , sau đó mở menu Network Setup (Cài đặt mạng).
2. Mở các menu sau đây:
  - **Wi-Fi Direct**
  - **On/Off** (Bật/Tắt)
3. Chạm vào mục **On** (Bật) trên menu.

### Phát hiện máy in

1. Từ thiết bị di động, bật Wi-Fi và tìm mạng không dây.
2. Chọn máy in như hiển thị trên bảng điều khiển máy in.  
**Ví dụ:** Direct-bb-HP M182 Laserjet

### Tìm hiểu thêm về tính năng in từ thiết bị di động

Để biết thêm thông tin về các nội dung này và các hệ điều hành khác (Chrome/Google Cloud Print), hãy truy cập vào [www.hp.com/go/LaserJetMobilePrinting](http://www.hp.com/go/LaserJetMobilePrinting) hoặc quét mã QR.



## Sử dụng tính năng quét

Hãy sử dụng phần mềm HP Scan trên máy tính của bạn để bắt đầu lệnh quét trên máy in.

### Windows

Nhấp vào **Start** (Bắt đầu), chọn **Programs** (Chương trình) hoặc **All Programs** (Tất cả chương trình), chọn **HP**, sau đó chọn **HP Scan**.

### OS X





Chuyển tới thư mục **Applications** (Ứng dụng) và mở **HP Smart**.

## Khắc phục sự cố

### Khắc phục sự cố kết nối không dây

Xác minh rằng máy in nằm trong phạm vi của mạng không dây. Đối với hầu hết các mạng, máy in phải nằm trong phạm vi 30 m (100 ft) của điểm truy cập không dây (bộ định tuyến mạng không dây). Có thể cần sử dụng cáp USB để kết nối tạm thời giữa máy in và máy tính. Đảm bảo rằng thông tin thiết lập không dây đồng bộ chính xác, không kết nối cáp USB cho đến khi được nhắc làm vậy.

#### Làm theo các bước sau để khôi phục cài đặt mạng:

1. Tháo cáp USB khỏi máy in.
2. Nhấn và giữ nút Không dây  trên bảng điều khiển máy in. Khi đèn LED Sẵn sàng  và đèn LED Chú ý  bắt đầu nhấp nháy cùng lúc, hãy nhả nút Không dây . Máy in sẽ tự động khôi phục cài đặt mạng mặc định và khởi động lại.
3. Khi đèn LED Sẵn sàng  bật, hãy tiếp tục cài đặt phần mềm.

### Tài nguyên hỗ trợ bổ sung và hướng dẫn sử dụng

Hướng dẫn sử dụng chứa thông tin về cách sử dụng và khắc phục sự cố với máy in. Bạn có thể xem hướng dẫn này trên trang web: Truy cập vào [www.hp.com/support/lj1182MFP](http://www.hp.com/support/lj1182MFP).

### Kiểm tra các bản cập nhật của chương trình cơ sở

1. Truy cập vào [www.hp.com/support/lj1182MFP](http://www.hp.com/support/lj1182MFP).
2. Chọn máy in hoặc danh mục từ danh sách, sau đó nhấp vào **Drivers** (Trình điều khiển).
3. Chọn hệ điều hành và nhấp vào nút **Next** (Tiếp).
4. Chọn **Firmware** (Chương trình cơ sở) và nhấp vào nút **Download** (Tải xuống).

### In không dây

Để biết thêm thông tin về thiết lập mạng không dây và in không dây, hãy truy cập vào [www.hp.com/go/wirelessprinting](http://www.hp.com/go/wirelessprinting).









Reproduction, adaptation or translation without prior written permission is prohibited, except as allowed under the copyright laws.

The information contained herein is subject to change without notice.

The only warranties for HP products and services are set forth in the express warranty statements accompanying such products and services. Nothing herein should be construed as constituting an additional warranty. HP shall not be liable for technical or editorial errors or omissions contained herein.

## Trademark Credits

Windows® is a U.S. registered trademark of Microsoft Corporation.

Apple and the Apple logo are trademarks of Apple Inc., registered in the U.S. and other countries.

App Store is a service mark of Apple Inc. Android, Google Play, and the Google Play logo are trademarks of Google Inc.

OS X is a trademark of Apple Inc., registered in the U.S. and other countries.

AirPrint is a trademark of Apple Inc., registered in the U.S. and other countries.



HP Color LaserJet Pro MFP M182n, M182nw, M183fw

## Informasi Importir

PT. Hewlett Packard Indonesia Gedung Perkantoran Prudential Center Kota Kasablanka Lantai 9, Jl. Casablanca Kav.88 Kel. Menteng Dalam, Kec. Tebet, Kota Administrasi Jakarta Selatan 12870

## Petunjuk Pemeliharaan

Petunjuk Pemeliharaan Lakukan prosedur pencegahan dasar setiap kali hendak menggunakan printer ini untuk mengurangi resiko cedera karena terbakar atau sengatan listrik:

1. Bacalah dan pahami seluruh petunjuk dalam dokumentasi yang menyertai printer.
2. Perhatikan semua tanda peringatan dan petunjuk yang tertera pada printer.
3. Cabut kabel printer dari stopkontak sebelum membersihkan.
4. Jangan memasang atau menggunakan printer ini dekat air atau saat Anda basah.
5. Letakkan printer dengan benar pada permukaan yang stabil.
6. Letakkan printer di lokasi yang aman dimana tak seorangpun dapat menginjak atau tersangkut kabel daya, dan agar kabel daya tidak rusak.
7. Jika printer tak beroperasi dengan normal, lihat berkas bantuan (tersedia di komputer begitu perangkat lunak telah diinstallkan).
8. Tidak ada komponen bagian dalam yang dapat diperbaiki pengguna. Serahkan perbaikan kepada petugas servis resmi.
9. Gunakan hanya dengan kabel daya dan adaptor daya yang disediakan HP.



[www.register.hp.com](http://www.register.hp.com)



Printed on recycled paper

